

VACUUM HOLDING TANK

OWNER'S MANUAL

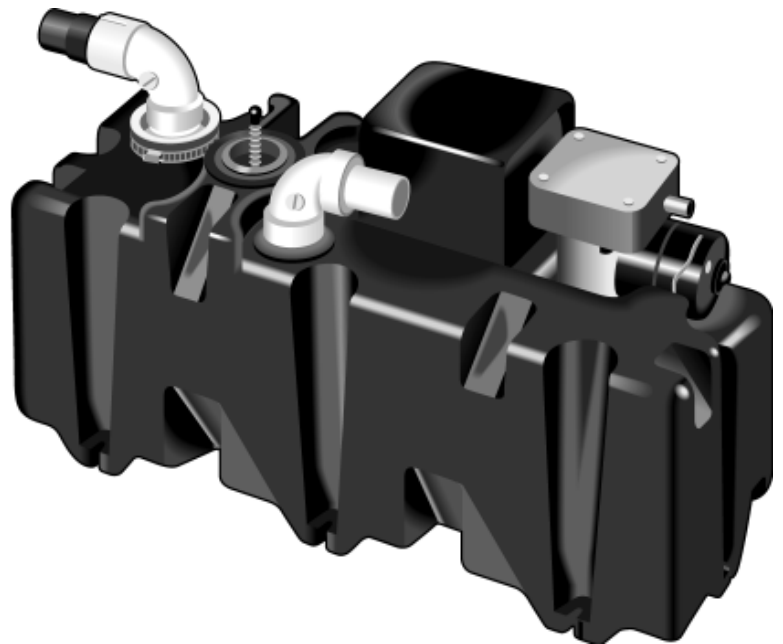

! WARNING

This manual must be read and understood before installation, adjustment, service, or maintenance is performed. Modification of this product can result in property damage.



Dometic Corporation • Sanitation Systems
13128 State Rt 226, PO Box 38
Big Prairie, OH 44611
SeaLand Product Customer Service: 1-800-321-9886
(8:00 a.m. - 5:00 p.m. ET)

TABLE OF CONTENTS

Product Features	2
Major Components	2
Principles of Operation	3
System Layout	3
Component Locating Procedure	4
Key Installation Points	4
Installation of Components	5
Winterizing	6
Troubleshooting Guide	6 - 7
Dimensional Specifications	7
Manufacturer's One-Year Limited Warranty	8

PRODUCT FEATURES

The Vacuum Holding Tank (VHT) brings the technology, comfort and efficiency of Dometic's renowned VacuFlush® vacuum sanitation systems to smaller boats in an easy-to-use, and easy-to-maintain package.

Simple Installation

- All system components are "installation ready."
- No solvent bonding is required.
- Removable hose insert fittings make hose installation simple.
- Vacuum pump and switch are pre-wired at factory.
- Easy to mount.

Reliability is Built-In

- No impellers or macerators. Motor can run without burning up.

MAJOR COMPONENTS

The Vacuum Holding Tank (VHT) system consists of a VacuFlush toilet or EcoVac™ toilet and the Model VHT Vacuum Holding Tank. The VHT is a unique combination of the vacuum tank, vacuum pump and holding tank components used in a standard VacuFlush toilet system.

VACUUM TOILETS

The VacuFlush 500 series features a large household-size bowl and seat. The VacuFlush 1000 series also features a deep bowl with an adult-sized seat. The EcoVac series offers space-saving models with adult-sized seats. All come with an attractive, easy-to-use flush pedal.

Each toilet series consists of several models, allowing for a multitude of installation variations: a rear discharge standard height unit, a bottom discharge standard height unit, and a bottom discharge low-profile unit designed to fit on a platform.

The vacuum toilet must be purchased separately; it is not included with the VHT.

VACUUM HOLDING TANK (VHT)

The VHT produces and stores vacuum between flushes. The vacuum holding tank is made of highly durable polyethylene. The pump is integrally connected with the vacuum tank. The vacuum pump is electric and draws only 2 to 4 amps of current at 12 VDC.

One vacuum holding tank is required for each toilet. Two or more toilets cannot be connected to one VHT.

The VHT contains the pre-set pressure differential switch control that turns the pump on and off when the proper level of vacuum is created.

A unique component on the VHT is the Vacuum Relief Valve (VRV). The VRV prevents excessive vacuum from accumulating in the tank. The VRV is calibrated to open at 13" of vacuum and close at 11" of vacuum. This feature is beneficial during pump-outs.

The VHT system comes equipped with a full level float switch. This float switch is wired directly to an automatic shutdown relay. The relay prohibits the vacuum pump from generating vacuum once the tank is full. A full level indicator light should be wired to the full float, by the installer. If a full level indicator light was not installed, order part number 318714 from Dometic. The indicator light is not part of the basic system.

VACUUM HOSE

To complete a VacuFlush installation, OdorSafe® Sanitation Hose or rigid PVC pipe (Schedule 40 or heavier) must be used. OdorSafe hose is specially formulated to provide up to 16 times greater resistance to malodors than other "no-odor" marine hoses.

PRINCIPLES OF OPERATION

VacuFlush systems use a small amount of water (one pint to one quart) and the vacuum that is generated by the vacuum pump to flush. Each toilet must be connected to a pressurized water system. Fresh water is recommended and will result in an odor-free bathroom. If seawater is used, the water should be filtered.

No complicated user instructions are required. Lifting the flush lever adds water to the bowl. Pressing the flush lever (or pulling the flush lever on a 106 toilet) opens a mechanical seal that allows the vacuum force to pull the waste from the bowl as clean water rinses the bowl. The vacuum moves the waste (at approximately 7 feet [2.1 m] per second) through a one-inch opening in the toilet base. Incoming air fragments the waste as it passes through the base opening. This process eliminates the need for macerators or mechanical motors in the toilet base.

Next, the waste is transferred into the Vacuum Holding Tank (VHT). System vacuum is monitored by a vacuum switch that is located on the outside of the VHT. When the switch senses a drop in vacuum in the system, it automatically signals the pump to energize and bring the vacuum back to operating level. This process is normally completed in about one minute.

In a properly operating system, the stored vacuum will "leak" down between flushes, causing the vacuum pump to run for a short period. The pump should not run more than once every three (3) hours after the last flush.

An "On-Off" night switch can be installed to silence the vacuum pump during sleeping hours. The VacuFlush Status Panel, an optional accessory, features an integral circuit breaker that provides a convenient night switch.

IMPORTANT: Before pumping out the VHT, it is recommended that the power to the system be turned off. Then, flush the toilet. This releases the stored vacuum in the tank, thus, allowing the dockside pump to empty the waste out more easily. If the dockside pump has low suction capability, you may need to flush the toilet a second time during the pump out.

The Vacuum Relief Valve (VRV) will automatically open at 13" of vacuum and is spring loaded to close at 11" of vacuum to prevent leaking during normal operation.

SYSTEM LAYOUT

The Vacuum Holding Tank (VHT) system can be installed on most boats that presently use a portable, manual or electric toilet. The following procedure will be helpful:

1. Review the typical system layout to get a general idea of how the system will operate and what discharge options will be considered (see Figure 1).
2. Draw or obtain a layout of the boat which allows the location of head compartments, bulkheads, engine space, tanks, through-hull fittings, etc. This layout should include top views and side views and show relative distances and heights with reasonable accuracy.
3. Use the information in the Component Locating Procedure section to help select the best locations for your boat layout.
4. Routing of vacuum hose should be considered when selecting a location for the toilet and the (VHT). A maximum of 20 feet (6.1 m) of hose can be used between the toilet and the VHT.
5. Before starting the actual installation, carefully review the Key Installation Points.

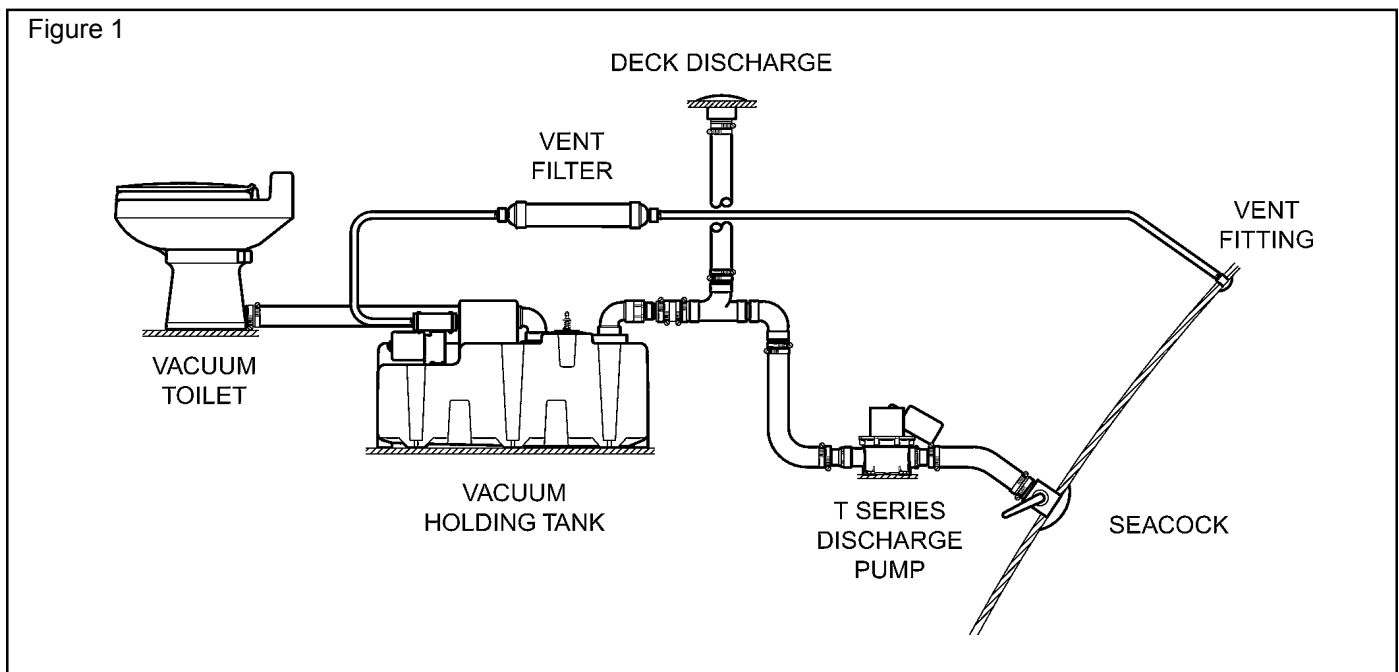

COMPONENT LOCATING PROCEDURE

Component	Location	Check
Vacuum Toilet	Bathroom compartment or under berth.	<ol style="list-style-type: none"> 1. Check dimensions of mounting space above and below floor. 2. Determine best toilet discharge connection: above floor, out rear or below floor. 3. Allow at least ½-inch (1.3 cm) clearance between toilet rear and wall. 4. Make sure compartment, shower and vanity doors will clear toilet bowl. 5. Check location nearest cold water line. 6. Water line must be at least ½-inch ID and provide a minimum flow of two (2) gallons per minute (7.6 liters per minute). 7. Water valve assembly for 106 toilet can be positioned any distance horizontally from the toilet but must be at least 6 in. (15.24 cm) above the top of the toilet bowl rim. 8. Check clearances to side wall for installation of flush lever cover and back wall for best clearance.
Vacuum Holding Tank (VHT)	Any space that permits access to remove the entire unit.	<ol style="list-style-type: none"> 1. The vacuum holding tank (VHT) inlet must be located no more than 20 feet (6.1 m) from the toilet discharge. 2. The VHT inlet must not be located more than 3 feet (.9 m) above the outlet of the toilet. (NOTE: The lower the tank, the better the system efficiency.) 3. The VHT must be mounted in a horizontal position. 4. The VHT must not be exposed to temperatures over 120°F. Do not place near heat sources such as engine manifolds, water heaters, generators, etc. Mounting space must provide for free air flow.
Vacuum Hose and Fittings	Use only Odor-Safe hose and SeaLand fittings. They are made to fit together.	<ol style="list-style-type: none"> 1. OdorSafe Sanitation Hose must be used; it is sized to use SeaLand fittings in the system, minimizing vacuum leakage. 2. It is important that restrictions in the vacuum hose be kept to a minimum. Where a bend must occur in a hose run, the radius of the bend must not be less than 6 inches (15.24 cm). If a tighter radius is required, use a SeaLand 90° bend kit to assure a clog-free transition.

KEY INSTALLATION POINTS

The VacuFlush system operates on a unique and uncommon principle – powerful, instantaneous vacuum force. As a result, certain installation points must be stressed because they are the most common sources of incorrect installation.

1. Leaks at Fitting Joints

One benefit of vacuum operation is that leaks are inward and will not cause drippage of sewage. Vacuum leaks result in frequent cycling of the vacuum pump which causes unnecessary wear on the motor and gear drive. Most vacuum leaks occur at fitting joints. Care should be taken to assemble fitting joints per the instructions. Allow time in your installation schedule to give cemented fittings, if used, time to cure before manipulating them. Also, a proper PVC cleaner or primer must be applied prior to cementing fittings.

2. Cementing Hose to Fittings

Never cement hose to fittings. The SeaLand custom hose adapter is specifically designed to fit precisely into the OdorSafe Hose. The hose will slide easily on the fitting if it is lubricated with liquid dishwashing detergent and twisted clockwise when attached.

3. Locating Components in Accessible Spaces

Never locate a component of the vacuum system in a space which is inaccessible or difficult to reach.

4. Hose... Too Much, Too Little

Try to avoid unnecessary hose runs that result in excessive bends or loops. Excessive hose reduces vacuum transfer efficiency. Hose should be securely tied down every three feet. Too little hose length also causes problems by forcing the hose into tight bends or kinks. Always leave a small amount of extra hose length for future maintenance. The distance between the toilet and the Vacuum Holding Tank (VHT) may not exceed 20 feet (6.1 m).

5. Hose... Wrong Type

To complete a VacuFlush installation, OdorSafe Sanitation Hose or rigid PVC pipe (Schedule 40 or heavier) must be used.

6. Hose... Odor Permeation

Avoid low spots in hose or sections where waste will remain for very long periods. Waste trapped in hose will produce gases in the final stage of decomposition that are very difficult to contain. If possible, have hose from the toilet drain into the VHT.

7. Protecting Toilet and Preventing Objects from Falling into System During Installation.

After mounting toilet and attaching seat and lid assembly, slide seat assembly carton over seat and lid. Next, place toilet box down over toilet. This will ensure additional protection to the toilet after installation.

Failure to follow recommended procedures that result in any of the above problems will invalidate component warranty.

INSTALLATION OF COMPONENTS

1. Installing the Toilet

For VacuFlush and EcoVac toilet mounting, follow the instructions in the VacuFlush Installation Guide.

2. Routing and Installing Hose

Before attaching the vacuum hose to a fitting, place two hose clamps over hose end. (All connections must be double clamped.) Apply liquid dishwashing soap to outside of hose connector and inside hose. Twist hose clockwise as it is pushed onto adapter (see Figure 2). Hose end should be flush against the fitting shoulder when properly installed (see Figure 3). Twist the hose counter-clockwise before placing it onto the fitting. This will ease installation. All joints should be double clamped with high quality stainless steel clamps. Make sure clamp mechanisms are 180° from each other when tight (see Figure 3). Failure to follow these procedures will result in vacuum leaks.

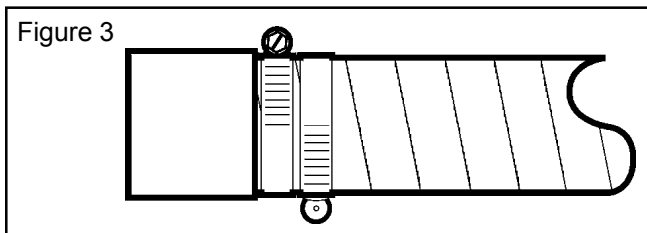

3. Connecting the Toilet Water Supply Lines

The water supply inlet must connect to an adapter which will adapt to the 1/2-inch MPT connection on the toilet water valve. (This adapter can be found through a local supplier or through Dometic.) The water supply must provide a minimum flow of two (2) gallons per minute (7.6 liters per minute).

4. Mounting the Vacuum Holding Tank

The Vacuum Holding Tank (VHT) can be located in any accessible space as long as the 1-1/2 inch hose is not longer than 20 feet (6.1 m) and its inlet is not higher than 3 feet (.9 m) from the toilet outlet. The VHT must be mounted horizontally.

Mounting spindles are provided for securing the VHT in areas that prevent access to the rear mounting feet on the VHT.

Position the VHT in the space intended. If using mounting spindles, mark holes at rear of tank. After holes are marked, remove VHT and secure (3) of the spindles provided to the mounting surface using (3) #12 x 1-1/2 inch long pan head wood screws. Slide the VHT back so mounting spindles fit into slots on tank (see Figure 4). Secure the tank by using the (3) remaining spindles and (3) #12 x 1-1/2 inch long pan head wood screws on remaining tank mounts.

If not using the mounting spindles, secure the VHT with (8) #12 x 1-1/2 inch long pan head wood screws and (8) flat washers on all (8) tank mounts. NOTE: The VHT must be secured by at least (6) of the (8) mounting feet.

Once the VHT is in place, connect hose from toilet. (NOTE: Hose insert elbow fittings can be removed from VHT.)

5. Making Electrical Connections

See the "Wiring Diagram" section of this manual.

6. Completing the Installation

Complete installation of discharge hose from outlet of VHT to a discharge deck fitting or overboard discharge pump.

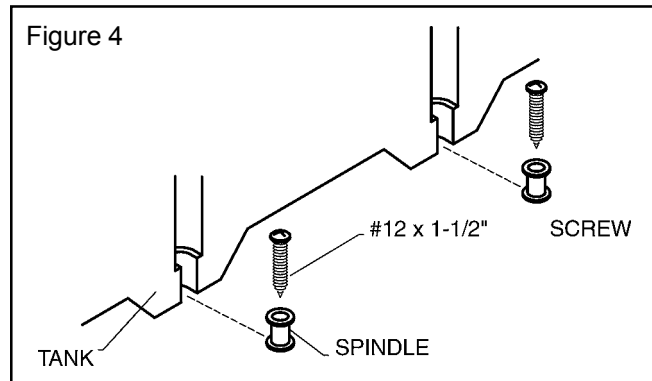

WINTERIZING

At the end of each boating season, the VacuFlush system must be winterized for storage. The following procedure should be used:

1. Thoroughly flush system with fresh water.
2. Pump out holding tank.
3. Shut off water supply to toilet, remove waterline.
4. Press flush lever until all water is drained from toilet.
5. Turn off electrical power.

To use antifreeze, repeat Steps 1 and 2 above and continue as follows:

CAUTION: The use of freshwater antifreeze that contains alcohol will result in damage to your sanitation system. Only use propylene glycol freshwater antifreeze that does not contain alcohol.

6. Drain potable water tank.
7. Add freshwater antifreeze to potable water tank.
8. Flush potable water antifreeze and water mixture through toilet and into the vacuum holding tank. Each installation is different so amounts may vary. User discretion is required to assure adequate protection.
9. Pump out vacuum holding tank.
10. Turn off electrical power.

TROUBLESHOOTING GUIDE

Problem	Possible Cause	Service Instructions
1. Pump running too much between flushes.	<ol style="list-style-type: none"> a. Flush ball in toilet leaks. b. Vacuum line leak. c. Foreign material has fouled air pump valves. d. Pump diaphragm worn or damaged. e. Duckbill valve in discharge fitting stuck open. 	<ol style="list-style-type: none"> a. Leave small amount of water in toilet. If water is sucked from bowl, refer to "Troubleshooting Guide" in VacuFlush Owner's Manual. b. Tighten all hose connections at pump, vacuum tank, holding tank, and toilet. c. Disassemble air pump and inspect under the two flat disk valves. If foreign material is present, remove debris and reassemble air pump. d. Inspect diaphragm in pump for small hole or rip. Replace if necessary. e. Disassemble discharge outlet and inspect duckbill valve. Clean or repair if necessary.
2. Toilet will not flush. (No vacuum.)	<ol style="list-style-type: none"> a. Pump will not run. b. Plugged vacuum line. c. Plugged pump valve. d. Vacuum pump discharge or intake lines plugged. 	<ol style="list-style-type: none"> a. See problem 3. b. Blockage usually at base of toilet below flush valve. You may have to disconnect line and clear. c. Inspect and clean pump valves. Replace if needed. d. Disassemble lines and clean.
3. Pump will not run.	<ol style="list-style-type: none"> a. No power. b. Loose or broken electrical wiring. c. Improper electrical connections. d. Faulty vacuum switch. e. Faulty motor. 	<ol style="list-style-type: none"> a. Check input power, circuit breaker and fuse. b. Tighten or reconnect wires at pump and vacuum tank. c. Make certain wires at vacuum switch are connected to the "B" terminals. d. To check vacuum switch, short across "B" terminals with jumper wire. e. Replace motor.
4. Pump will not shut off.	<ol style="list-style-type: none"> a. Insufficient vacuum. b. Excessive vacuum leak. c. Faulty vacuum switch. d. Improper wiring. 	<ol style="list-style-type: none"> a. Verify pump pulls minimum 10 inches Hg of vacuum. b. See problem 1. c. To check switch, remove one "B" terminal wire. d. Check wiring. Refer to Wiring Diagram.
5. Pump is making a loud noise. NOTE: If sound of pump is disruptive at night, an "On-Off" switch may be easily added to the system. The VacuFlush Status Panel features an integral circuit breaker which also serves as a night switch. (#500012, 12 VDC; #500024, 24 VDC)	<ol style="list-style-type: none"> a. Loose set screw in crank assembly. b. Pump bearing is worn. c. Dirt or debris in pump body. d. Worn or defective motor. e. Motor loose from mounting bracket. 	<ol style="list-style-type: none"> a. Remove cover from pump and check crank assembly setscrew for tightness. b. Check pump bearing for wear. Replace if needed. c. Disassemble air pump assembly and inspect inside of pump body for foreign objects. d. Replace motor assembly. e. Tighten the two (2) nuts securing the motor to the mounting bracket.

TROUBLESHOOTING GUIDE

Problem	Possible Cause	Service Instructions
6. Pump running too slow, overheating, blowing fuses or circuit breakers.	<ul style="list-style-type: none"> a. Improper voltage. b. Loose or broken electrical wiring. c. Improper wire size. d. Gear motor worn or defective. e. Tank is overfilled – air pump forced to pump water. 	<ul style="list-style-type: none"> a. Check input power for low voltage. b. Tighten or reconnect wires. c. Wire size too small – check electrical diagram for proper wire size for voltage of pump used. d. Check motor and replace if necessary. e. Disassemble air pump and empty out water.
7. Difficulty in emptying waste from holding tank.	<ul style="list-style-type: none"> a. The dockside pump is very weak and has low suction capability. 	<ul style="list-style-type: none"> a. Turn off the power to the VHT system. Flush the toilet, releasing all the stored vacuum. Begin pumping out. Repeat flushing if the dockside pump begins having trouble emptying out the waste.
8. Pump emits odor.	<ul style="list-style-type: none"> a. Worn, torn, or punctured pump diaphragm. 	<ul style="list-style-type: none"> a. Replace pump diaphragm.
9. System emits odor.	<ul style="list-style-type: none"> a. Check for improper flexible hose. 	<ul style="list-style-type: none"> a. Replace hose where necessary. Replacement hose should be marked "OdorSafe."

Important Owner Information: OdorSafe® Sanitation Hose is formulated for transfer of sanitary waste only. Do not allow the following items in system: Strong acids or caustic chemicals (example: drain openers), petroleum solvents or fuels, alcohol-based products (example: alcohol-based antifreeze), pine oil-based products (example: Pinesol® cleaner). Use of products containing these substances will void warranty on hose.

DIMENSIONAL SPECIFICATIONS

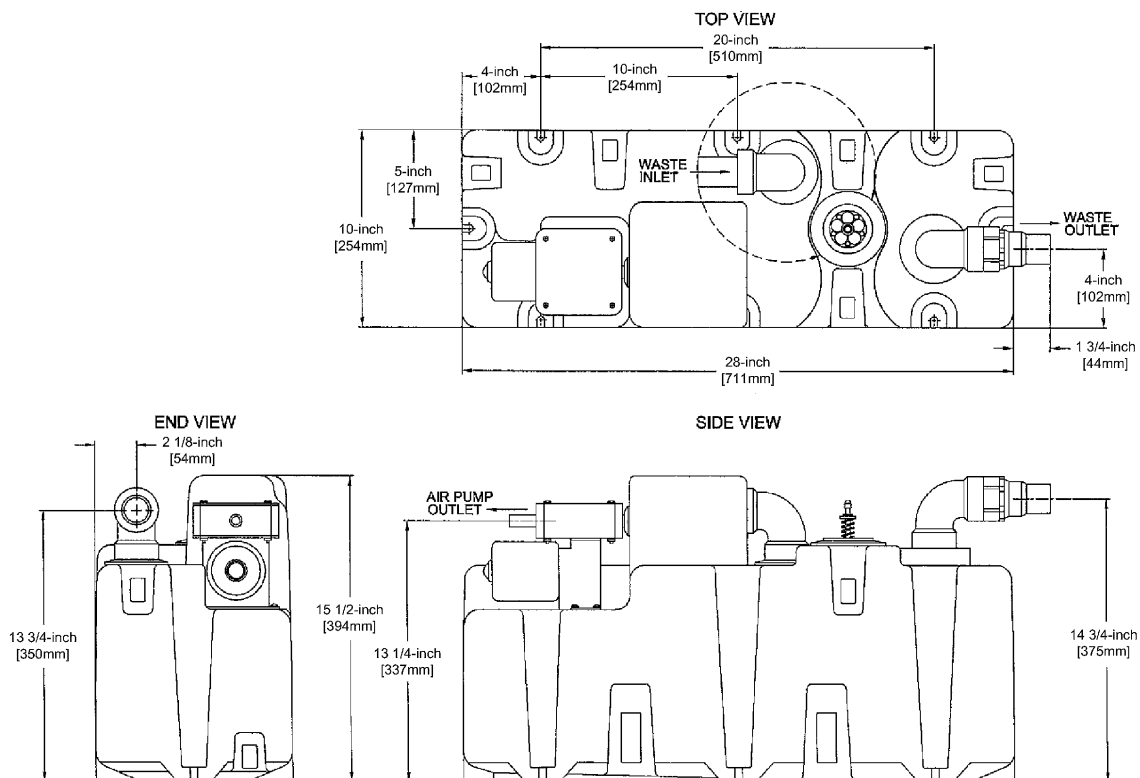

MANUFACTURER'S ONE-YEAR LIMITED WARRANTY

Dometic warrants, to the original purchaser only, that this product, if used for personal, family or household purposes, is free from defects in material and workmanship for a period of one year from the date of purchase.

If this Dometic product is placed in commercial or business use, it will be warranted, to the original purchaser only, to be free of defects in material and workmanship for a period of ninety (90) days from the date of purchase.

Dometic reserves the right to replace or repair any part of this product that proves, upon inspection by Dometic, to be defective in material or workmanship. All labor and transportation costs or charges incidental to warranty service are to be borne by the purchaser-user.

EXCLUSIONS

IN NO EVENT SHALL **DOMETIC** BE LIABLE FOR INCIDENTAL OR CONSEQUENTIAL DAMAGES, FOR DAMAGES RESULTING FROM IMPROPER INSTALLATION, OR FOR DAMAGES CAUSED BY NEGLIGENCE, ABUSE, ALTERATION OR USE OF UNAUTHORIZED COMPONENTS. ALL IMPLIED WARRANTIES, INCLUDING ANY IMPLIED WARRANTY OF MERCHANTABILITY OR FITNESS FOR ANY PARTICULAR PURPOSE, ARE LIMITED TO A PERIOD OF ONE YEAR FROM DATE OF PURCHASE.

IMPLIED WARRANTIES

No person is authorized to change, add to, or create any warranty or obligation other than that set forth herein.

Implied warranties, including those of merchantability and fitness for a particular purpose, are limited to one (1) year from the date of purchase for products used for personal, family or household purposes, and ninety (90) days from the date of purchase for products placed in commercial or business use.

OTHER RIGHTS

Some states do not allow limitations on the duration of an implied warranty and some states do not allow exclusions or limitations regarding incidental or consequential damages; so, the above limitations may not apply to you. This warranty gives you specific legal rights, and you may have other rights which may vary from state to state.

To obtain warranty service, first contact your local dealer from whom you purchased this product.



Dometic Corporation • Sanitation Systems
13128 State Rt 226, PO Box 38
Big Prairie, OH 44611
SeaLand Product Customer Service: 1-800-321-9886
(8:00 a.m. - 5:00 p.m. ET)

® Registered; ™ Trademark of Dometic Corporation
© Uniseal is a registered trademark of Injection Plastics, Inc.
© 2002 Dometic Corporation

Free Manuals Download Website

<http://myh66.com>

<http://usermanuals.us>

<http://www.somanuals.com>

<http://www.4manuals.cc>

<http://www.manual-lib.com>

<http://www.404manual.com>

<http://www.luxmanual.com>

<http://aubethermostatmanual.com>

Golf course search by state

<http://golfingnear.com>

Email search by domain

<http://emailbydomain.com>

Auto manuals search

<http://auto.somanuals.com>

TV manuals search

<http://tv.somanuals.com>