

## **DAYTONA USA DLX TABLE OF CONTENTS**

	<a href="#">INTRODUCTION OF THE OWNER'S MANUAL</a>	
1.	<a href="#">HANDLING PRECAUTIONS</a>	1
2.	<a href="#">PREVENTION OF COUNTERFEITING AND CONVERSION</a>	2
3.	<a href="#">PRECAUTIONS CONCERNING INSTALLATION LOCATION</a>	3
4.	<a href="#">NAME OF PARTS</a>	4
5.	<a href="#">ACCESSORIES</a>	5
6.	<a href="#">PRECAUTIONS TO BE HEEDED WHEN ASSEMBLING AND MOVING THE MACHINE</a>	6~15
7.	<a href="#">HOW TO PLAY</a>	16~17
8.	<a href="#">EXPLANATION OF TEST AND DATA DISPLAY</a>	18~32
8-1	<a href="#">SWITCH UNIT</a>	19
8-2	<a href="#">TEST MENU</a>	20
8-3	<a href="#">BOOKKEEPING</a>	21~22
8-4	<a href="#">GAME ASSIGNMENTS</a>	23
8-5	<a href="#">COIN ASSIGNMENTS</a>	24~25
8-6	<a href="#">INPUT TEST</a>	26
8-7	<a href="#">OUTPUT TEST</a>	27
8-8	<a href="#">DRIVE BD TEST</a>	28~29
8-9	<a href="#">SOUND TEST</a>	30
8-10	<a href="#">TGP TEST</a>	31
8-11	<a href="#">MEMORY TEST</a>	31
8-12	<a href="#">BACKUP DATA CLEAR</a>	32
9.	<a href="#">CONTROL PANEL (HANDLE MECHA)</a>	33~34
9-1	<a href="#">REPLACING AND ADJUSTING THE HANDLE's (STEERING WHEEL's) V.R.</a>	33
9-2	<a href="#">GREASING</a>	34
10.	<a href="#">ACCELERATOR &amp; BRAKE</a>	35
10-1	<a href="#">ADJUSTMENT AND REPLACEMENT OF VOLUME</a>	35
10-2	<a href="#">GREASING</a>	36
11.	<a href="#">4-SPEED SHIFTER</a>	36
11-1	<a href="#">REMOVING THE SHIFTER</a>	36
11-2	<a href="#">REPLACING THE SWITCH</a>	37

11-3	<a href="#">GREASING</a>	38
11-4	<a href="#">REPLACEMENT OF RUBBER STOPPERS</a>	38
12.	<a href="#">COIN SELECTOR</a>	39
13.	<a href="#">PROJECTOR</a>	40~43
13-1	<a href="#">CLEANING THE SCREEN</a>	40
13-2	<a href="#">HITACHI PROJECTOR</a>	41
13-3	<a href="#">MITSUBISHI PROJECTOR</a>	42
14.	<a href="#">REPLACING THE FLUORESCENT LAMP</a>	44
15.	<a href="#">PERIODIC CHECK</a>	44
16.	<a href="#">TROUBLESHOOTING</a>	45
17.	<a href="#">GAME BOARD</a>	46~47
17-1	<a href="#">REMOVING THE BOARD</a>	46
17-2	<a href="#">COMPOSITION OF GAME BOARD</a>	47
17-3	<a href="#">INPUT AND OUTPUT RELATIONS</a>	47
18.	<a href="#">DESIGN RELATED PARTS</a>	48~49
19.	<a href="#">PARTS LIST</a>	50~96
20.	<a href="#">WIRE COLOR CODE TABLE</a>	97
21.	<a href="#">WIRING DIAGRAM</a>	98~99

[\[Table of Contents\]](#)[\[Next Page\]](#)

## SPECIFICATIONS

<b>Installation space</b>	1,140 mm (W) x 2,800 mm (D) (44.9 in. x 110.2 in.)
<b>Height</b>	1, 870 mm (73.6 in.)
<b>Weight</b>	Approx. 375 kg. (825 lbs.)
<b>Power, maximum current</b>	725W 7.64A (AC 110V 50 Hz AREA) 736W 7.64A (AC 110V 60 Hz AREA) 735W 6.95A (AC 120V 60 Hz AREA) 735W 3.90A (AC 220V 50 Hz AREA) 725W 3.80A (AC 220V 60 Hz AREA) 730W 3.60A (AC 240V 50 Hz AREA) 740W 3.60A (AC 240V 60 Hz AREA)
<b>For TAIWAN (HITACHI PROJECTION DISPLAY TYPE) Power, current</b>	740W 7.70A (MAX.) 470W 5.25A (MIN)
<b>For TAIWAN (MITSUBISHI PROJECTION DISPLAY TYPE) Power, current</b>	700W 7.25A (MAX.) 430W 4.90A (MIN.)
<b>MONITOR</b>	50 INCH PROJECTION DISPLAY

NOTE: Descriptions in this manual are subject to change without prior notice.

## INTRODUCTION OF THE OWNER'S MANUAL

SEGA ENTERPRISES, LTD., supported by its high electronic technology of LSIs, microprocessors, etc. and a wealth of experience, has for more than 30 years been supplying various innovative and popular game machines to the world market. This Owner's Manual is intended to provide detailed descriptions together with all the necessary information covering the general operation of electronic assemblies, electromechanicals, servicing control, spare parts, etc. as regards DAYTONA USA DELUXE TYPE, a new SEGA product.

This manual is intended for those who have knowledge of electricity and technical expertise especially in ICs, CRTs, microprocessors, etc. Carefully read this manual to acquire sufficient knowledge before working on the machine. Should there be a malfunction, non-technical personnel should under no circumstances touch the interior system. Should such a case arise, contact our Main Office or the closest branch office listed as follows:

SEGA ENTERPRISES, INC. (U.S.A.)/CUSTOMER SERVICE  
45133 Industrial Drive, Fremont, California 94538, U.S.A.  
Phone : (415) 802-3100  
Fax : (415) 302-1754

SEGA AMUSEMENTS EUROPE LIMITED/AMUSEMENT MACHINE SALES DIVISION  
Unit 2 Industrial Estate, Leigh Close, New Malden, Surrey KT3 3NL, England  
Phone : (081) 336-2256

Fax : (081) 336-1715

SEGA SOUTHERN EUROPE LIAISON OFFICE  
Calle Vallellano, 19-23, 1 ° A, 37008-Salamanca, Spain  
Phone: (923) 265893  
Fax: (923) 265913

---

[\[Table of Contents\]](#)[\[Previous Page\]](#) [\[Next Page\]](#)

---

## 1. HANDLING PRECAUTIONS

When installing or inspecting the machine, be very careful of the following points and pay attention to ensure that the player can enjoy the game safely.

- Be sure to turn the power off before working on the machine.
- To insert or pull out the plug quickly is dangerous.
- It is necessary to make sure that the power cord or the grounding wire is not exposed on the road, etc. in a manner so as to be dangerous. Make sure that grounding connections are made safely at the position where so specified.
- Do not use any fuse that does not meet specified rating.
- Make complete connections for the IC board and other connectors. Insufficient insertion is very dangerous.
- The operating (ambient) temperature range is from 5°C to 40°C.
- When cleaning the CRT surfaces, use a soft, dry cloth. Do not apply chemicals such as thinner, benzene, etc.

Also, for the IC board circuit inspections, only the logic tester is allowed. The use of a tester is not permitted, so be careful in this regard.

After confirming that there are no irregularities, turn the power ON.

### CONCERNING THE PROJECTION DISPLAY:

A PROJECTION DISPLAY is used for this machine. The PROJECTION DISPLAY's screen is susceptible to damage and therefore, when cleaning it, pay careful attention. For details, refer to Section 13.

### CONCERNING COMMUNICATION PLAY:

Herein stated is an independent use of the machine. This game, when linked with other units, allows multiple persons to enjoy "communication play" simultaneously. For communication play, refer to Communication Manual.

---

[\[Table of Contents\]](#) [\[Previous Page\]](#) [\[Next Page\]](#)

---

## 2. PREVENTION OF COUNTERFEITING AND CONVERSION

### LABELING

To prevent counterfeits and conversions, the following labels are put on all the SEGA products. When handling such goods, be sure to confirm the labels. They are used to prevent illegal acts such as the unauthorized copying of the products and the printed circuit boards thereof or carrying on business by manufacturing similar merchandise or by converting, selling or using such products or printed circuit boards.

**ORIGINAL SEAL:** The left seal is put on the machines manufactured by SEGA.

**LICENSE SEAL:** The right seal is put on all SEGA kits, such as the printed circuit board.

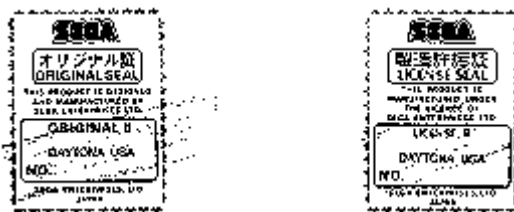

### COPYRIGHT NOTICE

This SEGA product has the copyright notice as follows:

(c) SEGA 1994

This signifies that this work was disclosed in 1994 and is the property of SEGA ENTERPRISES, LTD.

---

[\[Table of Contents\]](#) [\[Previous Page\]](#) [\[Next Page\]](#)

---

### 3. PRECAUTIONS CONCERNING INSTALLATION LOCATION

The DAYTONA USA DELUXE TYPE is an indoor game machine. Absolutely do not install it outside. Even indoors, avoid installing in places mentioned below so as to ensure proper usage:

- Places subject to rain or water leakage, or condensation due to humidity.
- In the proximity of an indoor swimming pool and/or shower.
- Places subject to direct sunlight.
- Places subject to heat sources from heating units, etc., or hot air.
- Vicinity of highly inflammable/volatile chemicals or hazardous matter.
- Sloped surfaces.
- Vicinity of anti-disaster facilities such as fire exits and fire extinguishers.
- Places subject to any type of violent impact.
- Dusty places.

#### INSTALLATION PRECAUTIONS

1. Do not insert more than one electrical plug into the power plug socket.
2. The per unit standard voltage/amperage is 100~120V/10A and 200~240V/5A.
3. Use of extension cables should be avoided. If you must use, ensure the extension cables are rated at 15A or higher for 100~120 volt areas or 7A or higher for 200~240 volt areas.
4. Note that for transporting the machine into the location's building, the minimum necessary dimensions of the opening (of doors, etc.) are 1 m (W) and 1.2 m (H).
5. For the operation of this machine, secure a minimum area of 1.5 m (W) x 2.8 m (D).

Electric current consumption:

MAX. 7.64A (AC 110V 50 Hz)  
MAX. 7.64A (AC 110V 60 Hz)  
MAX. 6.95A (AC 120V 60 Hz)  
MAX. 3.90A (AC 220V 50 Hz)  
MAX. 3.80A (AC 220V 60 Hz)  
MAX. 3.60A (AC 240V 50 Hz)  
MAX. 3.60A (AC 240V 60 Hz)

[\[Table of Contents\]](#) [\[Previous Page\]](#) [\[Next Page\]](#)

#### 4. NAME OF PARTS

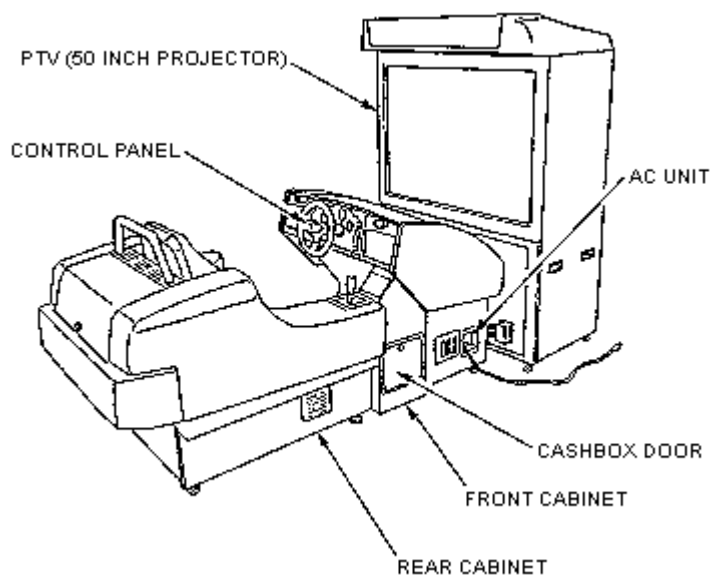

FIG. 4 OVERVIEW

Since the PTV and the Front Cabinet are connected with a tube, the cabinet is movable in the direction of depth for the purpose of maintenance. However, for the actual operation use, make sure that the PTV and the cabinet are tightly connected.

TABLE 4

	Width	Length	Height (mm.)	Weight (kg.)
PTV	1,140 X	880 X	1,870	135
REAR CABINET	1,000 X	1,405 X	1,130	128
FRONT CABINET	900 X	860 X	1,030	112
When assembled	1,140 X	2,800 X	1,870	375



[\[Table of Contents\]](#) [\[Previous Page\]](#) [\[Next Page\]](#)

## 5. ACCESSORIES

When transporting the machine, make sure that the following parts are supplied.

TABLE 5.1 ACCESSORIES

Part No.	Qty.	Part name	Note
200-5297	1	REMOTE CONTROLLER H (HITACHI)	For adjustment, refer to Section 13.
200-5298		REMOTE CONTROLLER M (MITSUBISHI)	
220-5373	2	VOL. CONT B-5K OHM	For spare, refer to Section 9.
220-5484		VOL. CONT B-5K OHM	
220-5381	2	KEY MASTER FOR 220-5380	For opening/closing the doors
	2	KEY	For the CASHBOX DOOR
420-6124-01	1	OWNERS MANUAL DAYTONA DX ENG	DAYTONA DX OWNER'S MANUAL, ENG.
421-8505-01	1	ADJUST INSTR SH DAYTONA DX	
509-5566	3	SW MICRO TYPE	For spare, refer to Section 11.
514-5036- 10000	1	FUSE 6.4 Øx 30 10000mA 125V	For spare, refer to Section 15.
514-5036- 15000	1	FUSE 6.4 Øx 30 15000mA 125V	AC110~120V AREA; For spare, refer to Section 6, 15.
514-5037- 8000	1	FUSE 6.4 Øx 30 8000mA 250V	AC220~240V AREA; For spare, refer to Section 6, 15.
540-0007-01	1	WRENCH FOR TAMP PRF SCR DUAL TYPE M5	Tool
540-0009-01	1	WRENCH FOR TAMP PRF SCR DUAL TYPE M8	Tool
DYN-2164	2	RUBBER STOPPER	For spare, refer to Section 11.

TOOL

(TAMPERPROOF WRENCH)  
M5 540-0007-01  
M8 540-0009-01

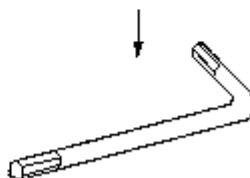

FIG. 6 TAMPERPROOF WRENCH

[\[Table of Contents\]](#) [\[Previous Page\]](#) [\[Next Page\]](#)

## 6. PRECAUTIONS TO BE HEEDED WHEN ASSEMBLING AND MOVING THE MACHINE

### WARNING:

1. Perform the assembly work by following the procedure herein stated. Failing to comply with the instructions, for example, inserting the plug into an outlet at the stage not mentioned in this manual might cause an electric shock accident.
2. Assembling should be performed as per this manual. Since this is a complex machine, erroneous assembling may cause damage to the machine, or malfunctioning to occur.
3. When assembling, be sure to perform the work by plural persons.

When carrying out the assembly work, follow the procedure in the following 7-item sequence:

1. ASSEMBLING THE PTV
2. ASSEMBLING THE CABINET
3. CONNECTING THE CABINET AND PTV
4. POWER SUPPLY, AND EARTH CONNECTION
5. TURNING THE POWER ON
6. ASSEMBLY CHECK
7. SECURING TO THE INSTALLATION POSITION (LEG ADJUSTER ADJUSTMENT)

Before starting assembly work, check to see if the parts, screws, etc. mentioned in the following Table are all available. Also, note that the master key (an accessory) in addition to the tools such as a plus screwdriver, wrench for M18 hexagon bolt and socket wrench is required for the assembling work.

TABLE 6.1 PARTS LIST

PART NO.	QU	DESCRIPTION	REMARKS	
200-5264	1	PROJECTION DISPLAY 50 H 24K HITACHI	2 screws used.	Assembled as per [1]
200-5265		PROJECTION DISPLAY 50 M 24K MITSUBISHI	2 screws used.	
DYN-0501	1	PANEL MOUNT BRKT L	2 screws used.	
DYN-0502	1	PANEL MOUNT BRKT R	2 screws used.	
DYN-0550	1	ASSY BILLBOARD	3 screws used.	
DYN-0600	1	ASSY FRONT PANEL	4 screws used.	
MGL-1104	2	MASK HOLDER	A total of 6 screws used.	
MGL-1105	1	TOP BRKT	3 screws used.	
MGL-1106	2	SIDE BRKT	A total of 4 screws	

			used.	
MGL-1150	1	ASSY MASK (TV MASK)	6 screws used.	
DYN-1000	1	ASSY FRONT CABINET		Connected as per [2]
DYN-2000	1	ASSY REAR CABINET		
DYN-0001	1	JOINT BRACKET R (L TYPE BRACKET R)	2 hexagon bolts used.	
DYN-0002	1	JOINT BRACKET L (L TYPE BRACKET L)	4 hexagon bolts used.	
600-6363- 82	1	CONNECT TUBE	8 Truss screws used.	Used as per [3]

[\[Table of Contents\]](#) [\[Previous Page\]](#) [\[Next Page\]](#)

## 7. HOW TO PLAY

Herein, explanations are given to the case of an independent play. Note that for communication play, some of the following points including the starting method, will not apply:

1. Take a ride in the machine. The seat position can be adjusted -forward and backward. For adjustments, pull the lever which is positioned on the lower left-hand side (facing the projector screen) of the seat.
2. Insert a coin. The coin chute door is on the right-hand side (facing the projector screen).
3. 3 courses appear on the screen in the sequence of Beginner, Advanced and Expert starting from the left. Turn the steering wheel to select the course and effectuate the selection by stepping on the Accelerator.
4. AUTO/MANUAL selection screen appears. By turning the steering wheel, choose AUTO or MANUAL and effectuate the selection by stepping on the Accelerator.
5. When choosing AUTO or MANUAL, stepping on the Accelerator while pressing the start SW will result in a TIME ATTACK mode in which no competitor car will appear and only the player's car will run.
6. When AUTO or MANUAL is determined, the game starts. Choosing the Beginner course results in a rolling start, the same as in the Daytona race. When the Advanced or Expert course is chosen, be sure to step on the Accelerator to start the machine.
7. The on-screen upper right-hand side, below the upper right, the upper middle, below the upper middle, the upper left-hand side and the lower right respectively indicates the player's present position, where other cars are, time limit, speed & tachometer, lap time and course map.

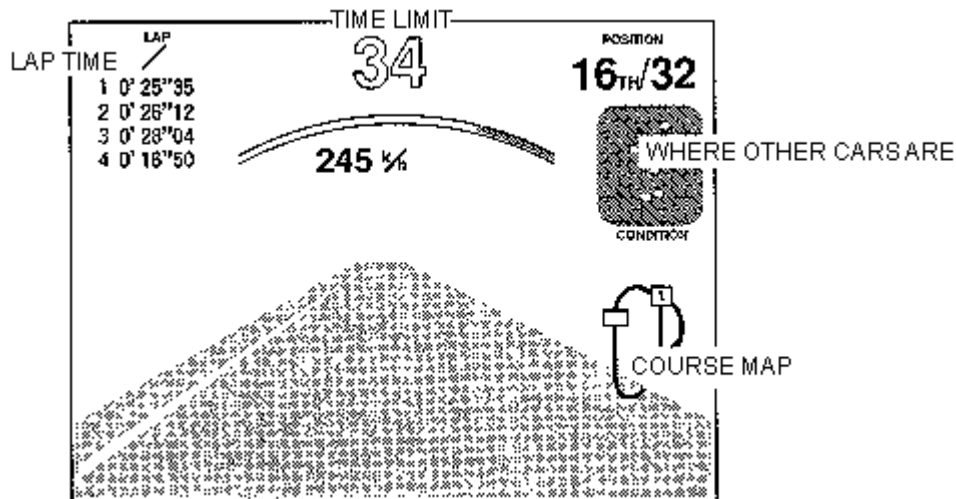

FIG. 7. 1

[\[Table of Contents\]](#) [\[Previous Page\]](#) [\[Next Page\]](#)

## 8. EXPLANATION OF TEST AND DATA DISPLAY

By operating the switch unit, periodically perform the tests and data check. When installing the machine initially or collecting cash, or when the machine does not function correctly, perform checking in accordance with the explanations given in this section.

The following shows tests and modes that should be utilized as applicable.

TABLE 8.1 EXPLANATION OF TEST MODE

ITEMS	DESCRIPTION	REFERENCE SECTIONS
INSTALLATION OF MACHINE	When the machine is installed, perform the following:	
	1. Check to see that each setting is as per standard setting made at the time of shipment.	8 - 4, 8 - 5
	2. In the INPUT TEST mode, check each SW and VR.	8 - 6, 8 - 8
	3. In the OUTPUT TEST mode, check each of lamps.	8 - 7
	4. In the SELF-TEST mode, check ICs on the IC Board.	8 - 10, 8 - 11
MEMORY	Choose MEMORY TEST in the MENU mode to allow the MEMORY test to be performed. In this test, PROGRAM RAMs, ROMs, and ICs on the IC Board are checked.	8 - 10, 8 - 11
PERIODIC SERVICING	Periodically perform the following:	
	1. MEMORY TEST.	8 - 10, 8 - 11
	2. Ascertain each setting.	8 - 4, 8 - 5
	3. In the INPUT TEST mode, test the CONTROL device.	8 - 6, 8 - 8
	4. In the OUTPUT TEST mode, check each of lamps.	8 - 7
CONTROL SYSTEM	1. In the INPUT TEST mode, check each SW and VR.	8 - 6, 8 - 8
	2. Adjust or replace each SW and VR.	9, 10, 11
	3. If the problem can not be solved yet, check the CONTROL's moves.	
MONITOR	In the MONITOR ADJUSTMENT mode, check to see if the PROJECTOR adjustment is appropriately made.	8 - 7, 13
IC BOARD	1. MEMORY TEST	8 - 10, 8 - 11
	2. In the SOUND TEST mode, check the sound related ROMs.	8 - 9
DATA CHECK	Check such data as game play time and histogram to adjust the difficulty level, etc.	8 - 3

---

[\[Table of Contents\]](#) [\[Previous Page\]](#) [\[Next Page\]](#)

---

### CAUTIONS TO BE HEDED WHEN USING THE TEST MODE:

In the case where multiple units are linked for communication play, exiting from the test mode causes the unit to perform the network check automatically. During this time, all of the linked units will not allow the game to be played in normal status. Therefore, be sure not to enter the test mode if any one of the units is in play. On the other hand, if even one unit is in the test mode, make sure that other machines are not in play.

#### 8-1 SWITCH UNIT

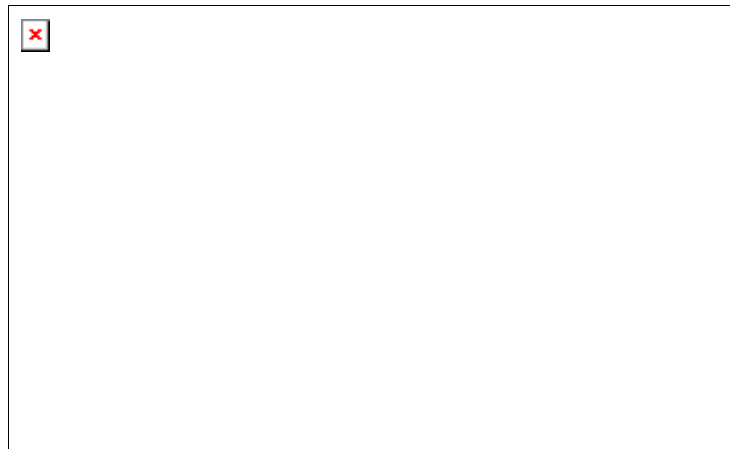
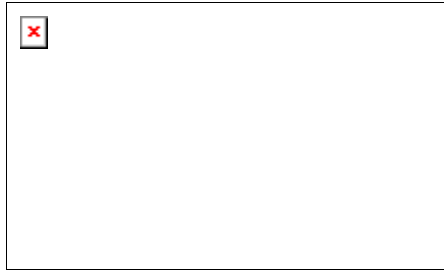

FIG. 8.1 SWITCH UNIT

Open the coin chute door, and the switch unit shown will appear. The functioning of each SW is as follows:

TEST SWITCH (TEST)	: For the handling of the test button, refer to the following pages.
SERVICE SWITCH (SERVICE)	: Gives credits without registering on the coin meter.
SOUND VOLUME (FRONT VOL, SUPERWOOFER)	: Adjusts the volume of the control panel's speakers and Superwoofer under the seat.
SOUND VOLUME (REAR VOL)	: Adjusts the volume of the 2 rear speakers behind the seat and the control panel's tweeter.

The control panel switches are also used in the test mode. For each functioning, refer to the following page and onward.



---

[\[Table of Contents\]](#) [\[Previous Page\]](#) [\[Next Page\]](#)

---

## 8-2 TEST MODE

- The Test Menu allows the functioning of each part of the Cabinet to be checked, the PROJECTOR to be adjusted, and the coins and game related various settings to be performed.
- Press the TEST SWITCH to cause the following Test Menu to be displayed on the monitor. (FIG. 8. 2)
- Press the SERVICE SWITCH until the pointer ">>" is moved to the desired item. Also, note that pressing VRI (red) causes the arrow to move downward and pressing VR4 (green) causes the arrow to move upward.
- Bring the pointer ">>" to the desired test item and press either the TEST SWITCH or START SWITCH to cause the selected item's test to start.

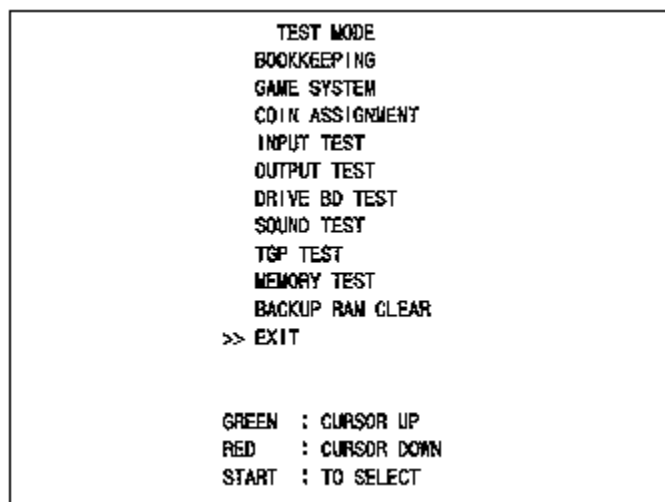

FIG. 8. 2 TEST MENU

After the test is complete, move ">>" to "EXIT" and press the TEST SWITCH or START SWITCH to return to the Game Mode.



[\[Table of Contents\]](#) [\[Previous Page\]](#) [\[Next Page\]](#)

### 8-3 BOOKKEEPING

Selecting the BOOKKEEPING in the menu mode causes the bookkeeping data up to the present to be displayed on 2 pages.

- Press the TEST SW or START SW to return to the MENU mode screen.
- Press VR1 (red) to proceed to the other page.

```

BOOKKEEPING
COIN CHUTE #1 XXXXXXXX
COIN CHUTE #2 XXXXXXXX
TOTAL COINS XXXXXXXX
COIN CREDITS XXXXXXXX
SERVICE CREDITS XXXXXXXX
TOTAL CREDITS XXXXXXXX
NUMBER OF GAMES XXXXXXXX
TOTAL TIME  xDxxHxxMxxS
GAME PLAY TIME  xDxxHxxMxxS
AVERAGE GAME TIME  xxMxxS
LONGEST GAME TIME  xxMxxS
SHORTEST GAME TIME  xxMxxS

START : TO EXIT
RED   : TO OTHER PAGE
  
```

FIG. 8.3a BOOKKEEPING

COIN CHUTE # *:	Number of coins put in. As seen from the front of the cabinet, the right-hand side is #1 and the left- hand side is #2.
TOTAL COINS:	Total number of activations of coin chutes
COIN CREDITS:	Number of credits registered by inserting coins
SERVICE CREDITS:	Credits registered by the SERVICE switch
TOTAL CREDITS:	Total number of credits (COIN CREDITS + SERVICE CREDITS)
TOTAL TIME:	The total energized time.

[\[Table of Contents\]](#) [\[Previous Page\]](#) [\[Next Page\]](#)

#### 8-4 GAME SYSTEM

Selecting the GAME SYSTEM in the menu mode causes the present game setting to be displayed and also the game setting changes can be made. Each item displays the following content. Settings at the time of shipment are as follows:

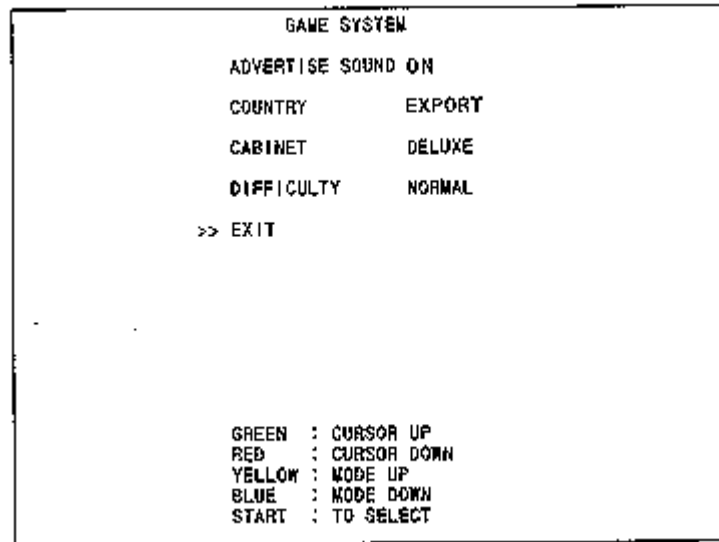

FIG. 8.4 GAME SETTING

ADVERTISE SOUND	Advertisement sound during standby. No sound is produced with "OFF." Standard setting is "OFF."
COUNTRY	Message language (select USA for the U. S. A., and EXPORT for other countries).
CABINET	Setting of cabinet. In this machine, set to DELUXE.
DIFFICULTY	The game difficulty is classified into 4 different categories from EASY to HARDEST. Standard setting is "NORMAL."

#### SETTING CHANGE PROCEDURE

1. Press the SERVICE SW or VR1 (red), or VR 4 (green) to move the arrow (>>) to the desired item.
2. Choose the desired setting change item by using any one of VR2 (blue), VR3 (yellow), TEST SW and START SW.
3. To return back to the MENU mode, move the arrow to EXIT and press the TEST SW or START SW.

[\[Table of Contents\]](#) [\[Previous Page\]](#) [\[Next Page\]](#)

## 8-5 COIN ASSIGNMENT

The "COIN ASSIGNMENTS" mode permits you to set the start number of credits, as well as the basic numbers of coins and credits. This mode expresses "how many coins correspond to how many credits."

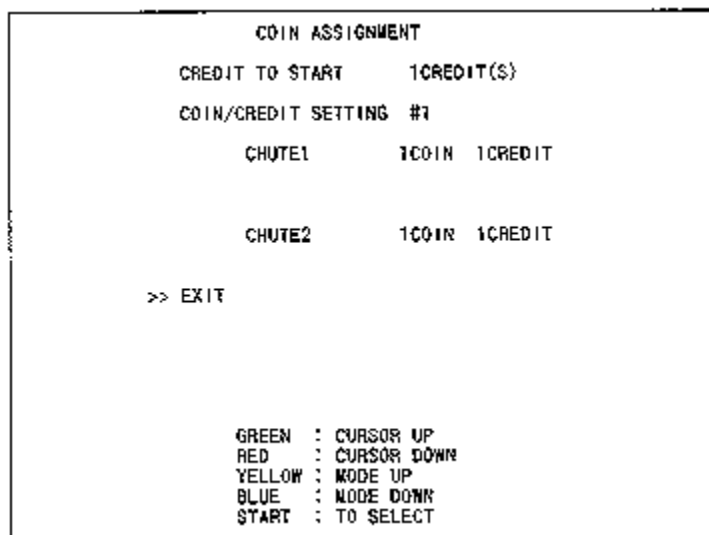

FIG. 8.5 COIN ASSIGNMENTS

CREDIT TO START	Number of credits required for starting game (1~5 credits are selected.)
COIN/CREDIT SETTING	"How many coins correspond to how many credits." In this machine, selection as per Table 8.2 is possible.

## SETTING CHANGE PROCEDURE

1. Press the SERVICE SW or VR1 (red), or VR 4 (green) to move the arrow (>>) to the desired item.
2. Choose the desired setting change item by using any one of VR2 (blue), VR3 (yellow), TEST SW and START SW.
3. To return back to the MENU mode, move the arrow to EXIT and press the TEST SW or START SW.

---

[\[Table of Contents\]](#) [\[Previous Page\]](#) [\[Next Page\]](#)

---

## 8-6 INPUT TEST

When INPUT TEST is selected, the monitor will show the following, allowing you to watch the status of each switch and the value of each V.R. of the CONTROL PANEL.

On this screen, periodically check the status of each switch & V.R.

- By pressing each switch, if the display on the right-hand side of the name of each switch changes to ON from OFF, the SW and the wiring connections are satisfactory.
- To check CHUTE 1 & CHUTE 2 coin switches, open the COIN CHUTE DOOR and insert a coin (s) from the coin entry.
- To return back to the MENU mode, simultaneously press VR1 & VR2, or press the TEST SW.

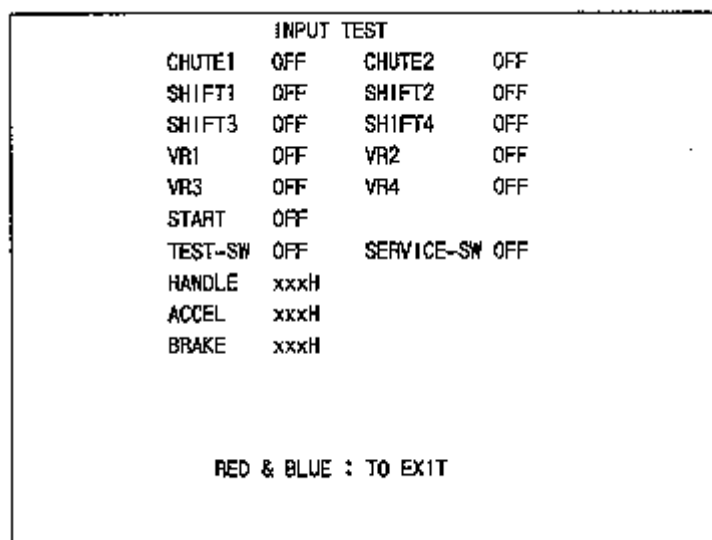

**FIG. 8.6 INPUT TEST**

An appropriate value of each V.R. is as follows:

HANDLE:	Under 2DH	<-- 7D~83H -->	Over D3H
	left	(Centering position)	right
ACCEL:	Under 30H	--->	Over COH
BRAKE:	Under 30H	--->	Over D2H
	(the pedal released)		(the pedal stepped)

---

[\[Table of Contents\]](#) [\[Previous Page\]](#) [\[Next Page\]](#)

---

### 8-7 OUTPUT TEST

Choose OUTPUT TEST to cause the following topmost screen to appear. In this test, periodically adjust the projector and check the status of each lamp.

The FIG. below shows the menu mode of OUTPUT TEST. Press the SERVICE SW or VR4 (green)/VR1 (red) and bring the arrow (>>) to the desired test item.

Press the TEST SW or START SW to cause the test mode screen below to appear. To return back to the menu mode, bring the arrow to EXIT and press the TEST SW or START SW (FIG. 8.2)

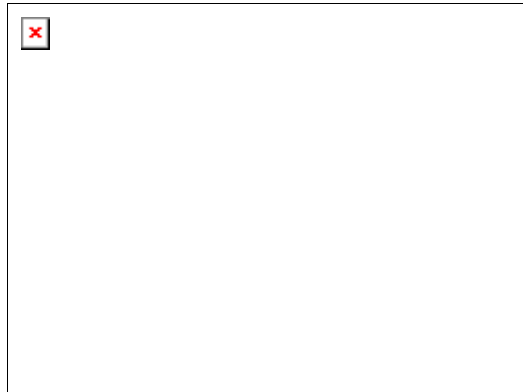

Choose CRT SIZE to cause the screen shown below to appear. Adjust the projector (monitor) to make sure that the crosshatch lines do not go beyond the screen size and crosshatch distortion does not occur. Press the START SW to return to the above OUTPUT TEST menu screen.

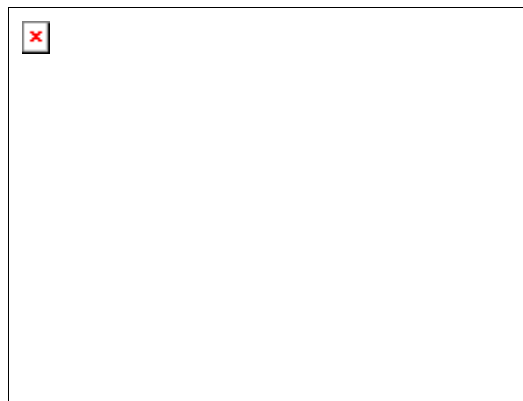

Choose CRT COLOR to cause the screen shown at the left to appear. This test allows the on- screen color adjustment to be performed. The color of a color bar (for each of the 4 colors, i. e., red, green, blue, and white) is darkest at the leftmost end and brightest at the rightmost end.

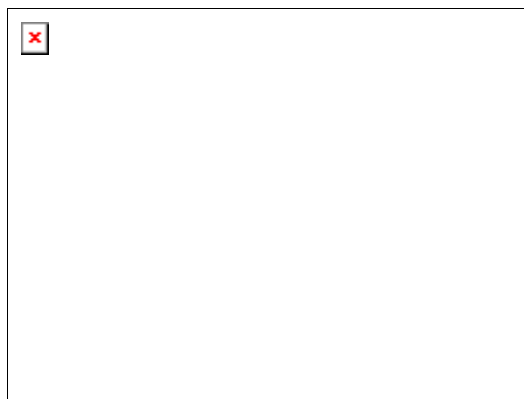

Choose LAMP to cause the screen shown at the left to appear. This enables the status of each lamp to be checked. Causes the START SW lamp and the lamp of each V. R. switch to light up in a sequential order. Press the START SW to return to the above OUTPUT TEST menu screen.



[\[Table of Contents\]](#) [\[Previous Page\]](#) [\[Next Page\]](#)

## 8-8 DRIVE BD TEST

Choosing DRIVE BD TEST allows the reaction mechanism of the steering wheel to be checked. Also, this enables the V.R. value for the steering wheel's DRIVE BD and the setting status of the DIP SWes on the Drive BD to be checked.

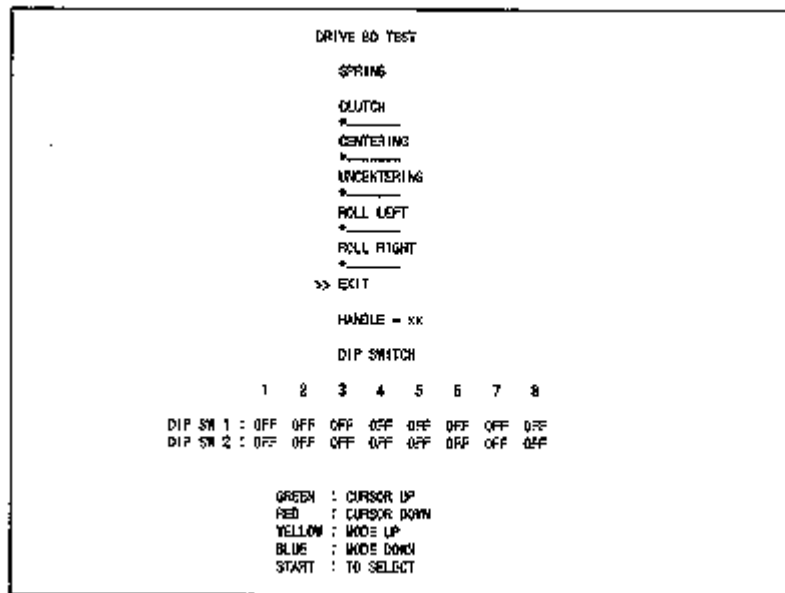

FIG. 8.8 DRIVE BD TEST

Bring the arrow (>>) to the desired item by using the SERVICE SW or VR1 (red) or VR4 (green). The steering wheel functions to the setting selected by the arrow. Pressing VR2 (blue) or VR3 (yellow) allows the force transmitted to the steering wheel to increase or decrease.

SPRING:	Status in which the motor and clutch are not activated. Centering of the handle is caused by only the spring inside the handle mechanism.
CLUTCH:	Status in which the clutch is activated. The handle is fixed.
CENTERING:	Status in which the handle (of itself) returns to the center position.
UNCENTERING:	Status in which the handle is caused not to be in the center.
ROLL LEFT:	Status in which the handle is rotated in the left-hand side direction
ROLL RIGHT:	Status in which the handle is rotated in the right-hand side direction.
EXIT:	Causes the menu mode to return on to the screen.

[\[Table of Contents\]](#) [\[Previous Page\]](#) [\[Next Page\]](#)

## 8-9 SOUND TEST

Choosing SOUND TEST causes the following mode to appear on the screen. This allows the desired sound (BGM, announcement and sound effects) to be chosen and heard. Enables the SOUND BD, AMP BD and each speaker to be checked.

Press the SERVICE SW or VR1 (red) or VR4 (green) and bring the arrow (>>) to the desired sound item to be tested. Pressing the TEST SW or START BUTTON allows the selected sound test to be performed.

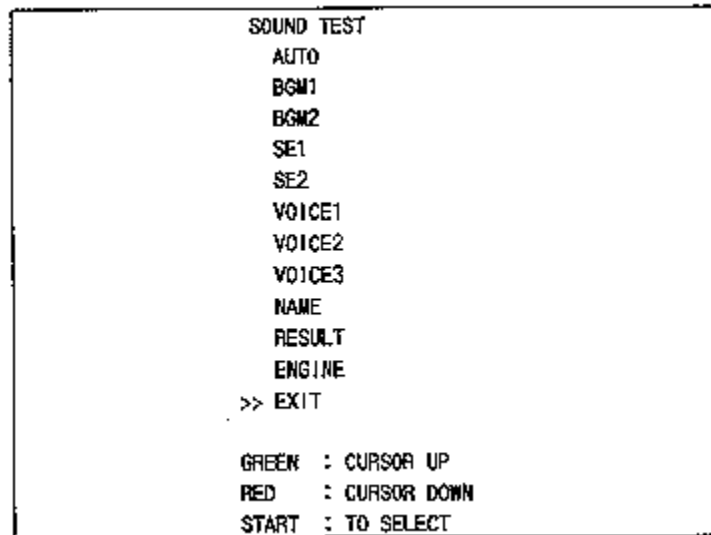

FIG. 8.9 SOUND TEST

AUTO:	Auto play covering from BGM to RESULT. Bring the arrow to this item and press TEST SW or START BUTTON to cause SOUND TEST covering from BGM to RESULT will be automatically and repeatedly be performed.
BGM:	Background music during game.
SE:	Sound effects during game.
VOICE:	Announcement and comment during game.
NAME:	Announcement and comment during name entry.
RESULT:	Announcement during the display of the results.
ENGINE:	Engine/Slip/Brake sounds can be emitted by using the ACCEL. pedal, HANDLE pedal and BRAKE pedal respectively.
EXIT:	Causes the menu mode to return on to the screen.



---

[\[Table of Contents\]](#) [\[Previous Page\]](#) [\[Next Page\]](#)

---

### 8-10 TGP TEST

In this test, TGP (on-screen display related IC) is checked. As shown below, if "GOOD" is displayed for all, it is satisfactory. Press TEST SW or START BUTTON to return to the menu screen.

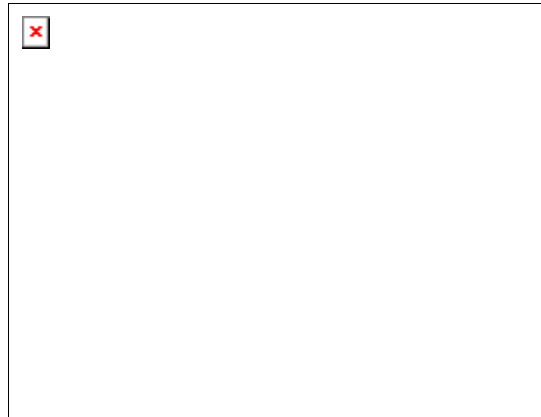

FIG. 8.10 TGP TEST

### 8-11 MEMORY TEST

The MEMORY TEST mode is for checking the on-BD memory IC functioning. "GOOD" is displayed for normal ICs and "BAD" is displayed for abnormal ICs.

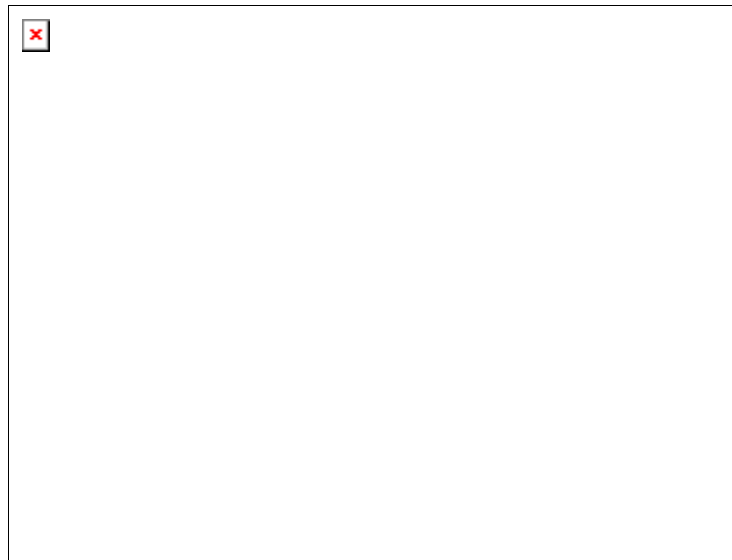

FIG. 8.11 MEMORY TEST

- When the test is completed, if the results are shown as above, it is satisfactory.
- It takes approximately thirty seconds to complete the test. If the period exceeds thirty seconds, this may have been caused by board malfunctioning.

- After finishing the test, pressing the TEST SW or START BUTTON allows the MENU mode to return on to the screen.

---

[\[Table of Contents\]](#) [\[Previous Page\]](#) [\[Next Page\]](#)

---

## 8-12 BACKUP RAM CLEAR

Clears the contents of BOOKKEEPING.

When clearing, bring ">>" to "YES" and when not clearing, to "NO", by using the SERVICE SW or VR1 (red)/VR4 (green), and then push the TEST SW or START BUTTON.

When the data has been cleared, "COMPLETED" will be displayed. Bring ">>" to "NO" and press the TEST SW to cause the Menu mode to return on to the screen.

Also, note that the game setting contents are not affected by BACKUP RAM CLEAR operation.

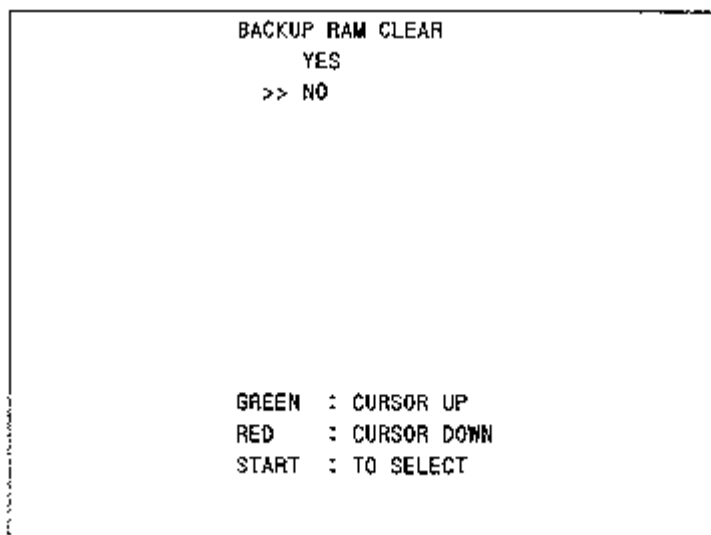

FIG. 8.12 BACKUP RAM

---

[\[Table of Contents\]](#) [\[Previous Page\]](#) [\[Next Page\]](#)

---

## 9. CONTROL PANEL (HANDLE MECHA)

In the TEST mode, if the steering wheel V. R. value variations are not within the allowable range, an adjustment of the V. R. installation position or replacement of the V. R. are needed. Also, apply grease to the steering wheel mechanism's shaft and sliding portions once every 3 months. When carrying out the above work, take off the 4 truss screws and remove the front cab's Front Lid Upper.

### 9-1 REPLACING AND ADJUSTING THE HANDLE's (STEERING WHEEL's) V.R.

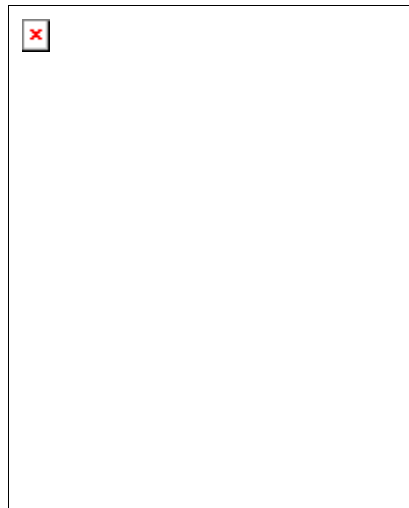

FIG. 9.1

The upper side V. R. of the HANDLE MECHA is for the GAME BD., and the lower side one. for the DRIVE BD. Check the value of the V. R. for the DRIVE BD. The appropriate value of each V. R. is as follows:

When the steering wheel is turned to or positioned at:	Left	Centering position	Right
V. R. for the GAME BD.:	Under 2 DH	--7DH~83H -->	Over D3H
V. R. for the DRIVE BD.:	Under 2 DH	--7DH~83H -->	Over D3H

#### Method of V. R. replacement

To replace the V. R., after taking off the connector from the V. R. to be replaced, take out the 2 screws which secure the VR BRACKET, and remove the V. R. together with the bracket and gear. After the replacement, check the V. R. value variations in the test mode.

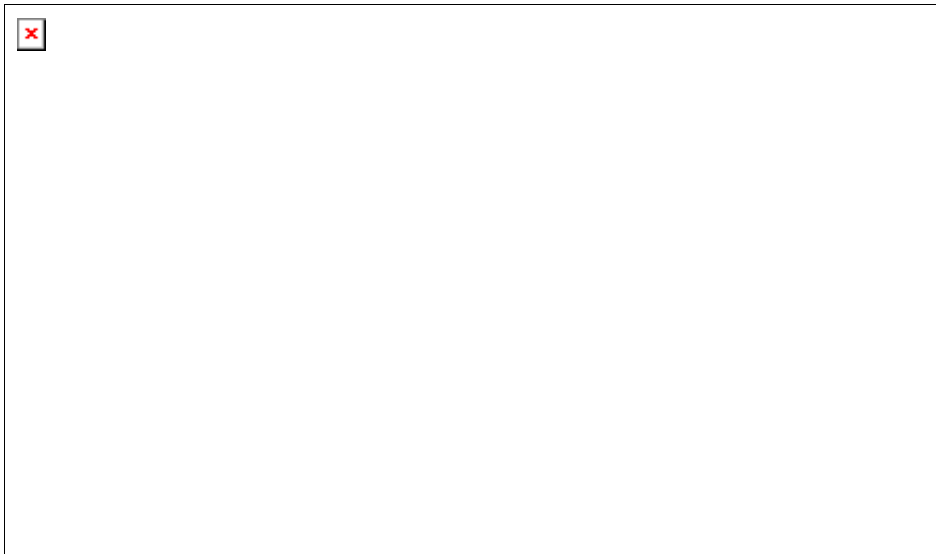

---

[\[Table of Contents\]](#) [\[Previous Page\]](#) [\[Next Page\]](#)

---

### **Method of V. R. adjustment**

1. Loosen the 2 screws which secure the V. R. BRACKET, move the V. R. BRACKET and detach the gears.
2. Adjust the V. R. so that it is consistent with the value near the centering position.
3. Cause the gears to be engaged and secure the V. R. BRACKET. At this time, make sure that an appropriate backlash is obtained.
4. If the V. R. value is not appropriate when the steering wheel is at the centering position, loosen the 2 screws which secure the V. R. gear, turn the gear holder to make a fine adjustment so that the V. R. value is within the allowable range.
5. Check the V. R. value variations by turning the handle.

### **9-2 GREASING**

Once every 3 months, grease the gears, bearings, springs, and cam & arm's sliding portions.

---

[\[Table of Contents\]](#) [\[Previous Page\]](#) [\[Next Page\]](#)

---

## 10. ACCELERATOR & BRAKE

In the test mode, if the ACCEL. & BRAKE V.R. value is not within the allowable range, an adjustment of V.R. installation position, or a replacement of V.R. is needed. Also, grease the MECHA's shafts and sliding portions once every 3 months.

When performing the above work, take off the 4 truss screws and remove the front cab's front lid.

### 10-1 ADJUSTMENT AND REPLACEMENT OF VOLUME



FIG. 10.1

The ACCEL. & BRAKE MECHA can be seen by removing the front lid. The ACCEL. V.R. is on the left-hand side and the BRAKE V.R. is on the right-hand side of the MECHA. Check the V.R. value in the test mode. The appropriate value of each V.R. is as follows:

	When released:	When stepped on:
ACCEL.:	Under 2 DH <--->	Over D3H
BRAKE:	Under 2 DH <--->	Over D3H

#### Method of V. R. replacement

To replace the V.R., after taking off the connector from the V.R. to be replaced, take out the 2 screws which secure the VR BRACKET, and remove the V.R. together with the bracket and gear. After the replacement, check the V.R. value variations in the test mode.

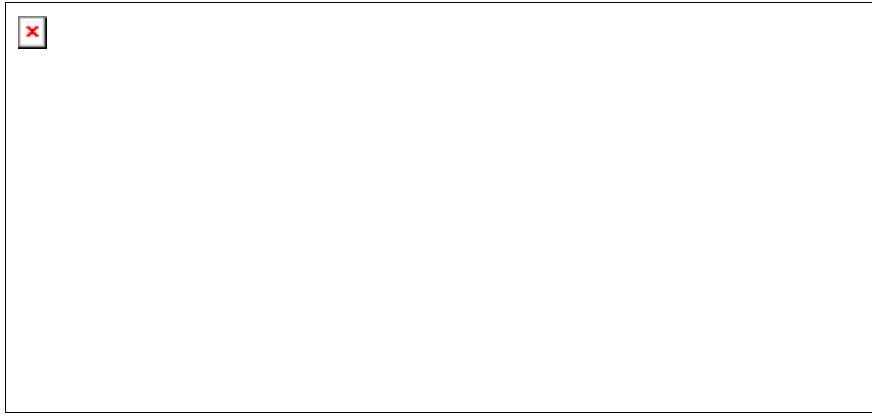



---

[\[Table of Contents\]](#) [\[Previous Page\]](#) [\[Next Page\]](#)

---

#### **METHOD OF V.R. ADJUSTMENT**

1. Loosen the 2 screws which secure the V.R. BRACKET, move the V.R. BRACKET and disengage the gears.
2. Cause the V.R. value to match with the value obtained when the pedal is released.
3. Cause the gears to be engaged and secure the V.R. BRACKET. At this time, be sure to obtain an appropriate backlash.
4. Step on the pedal and check the V.R. value variation.

#### **10-2 GREASING**

Grease the gears and bearings once every 3 months as a standard.

#### **11. 4 SPEED SHIFTER**

In the test mode, if the shift lever input is found to be irregular, replace the switch or adjust the switch installation position. Also, grease the MECHA's shafts or sliding portions once every 3 months as a standard.

When performing the above work, remove the shift lever unit.

#### **11-1 REMOVING THE SHIFTER**

1. Take off the 4 tamperproof screws and remove the design plate.
2. Take out the 4 hexagon bolts and pull the shift lever unit upward. At this time, pay careful attention so as not to cause damage to the wiring.
3. Disconnect the two connectors to allow the unit to be removed.

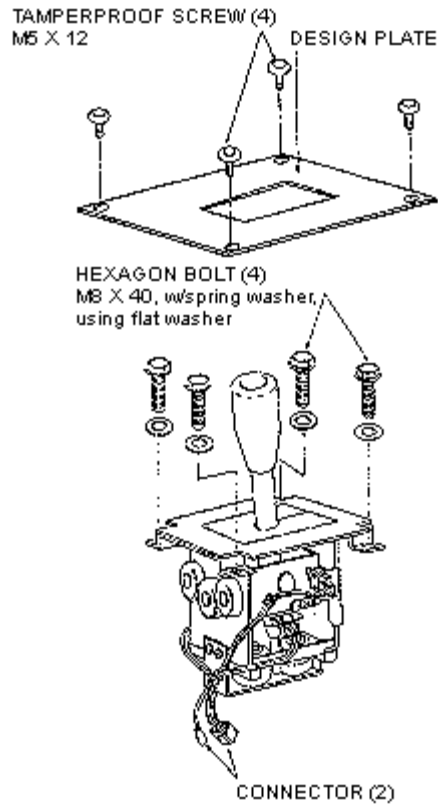

FIG. 11.1

---

[\[Table of Contents\]](#) [\[Previous Page\]](#) [\[Next Page\]](#)

---

## 11-2 REPLACEMENT AND ADJUSTMENT OF SWITCH

### Method of replacement

1. Disconnect the wiring connector of the SW to be replaced.
2. Take off the 2 screws which secure the BRACKET (SW BRACKET A & B) to which the SW is attached, and remove the SW together with the bracket. (FIG. 11.2)
3. Take off the 2 screws which secure the SW, and replace the SW.

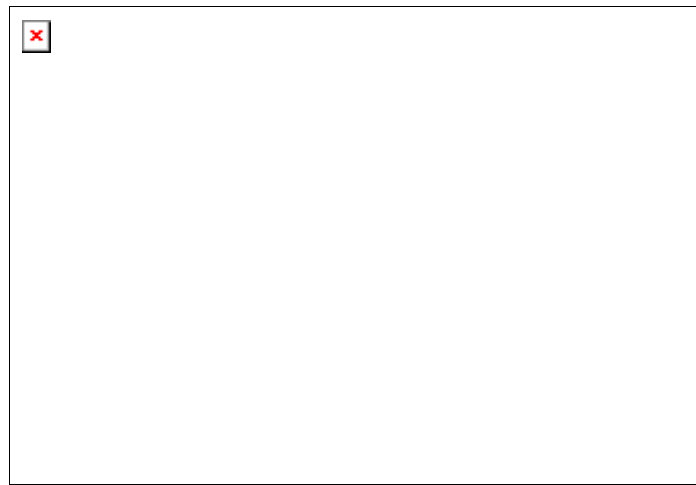

FIG. 11.2

1. To secure the replaced SW to the bracket, incline it as shown (FIG. 11.3). Securely fasten the screws by applying an anti-loosening agent to the screws.
2. Install the SW bracket with 2 screws. When installing SW BRACKET A, an adjustment in the following procedure is required.
3. After SE replacement, check the SW input in the test mode.

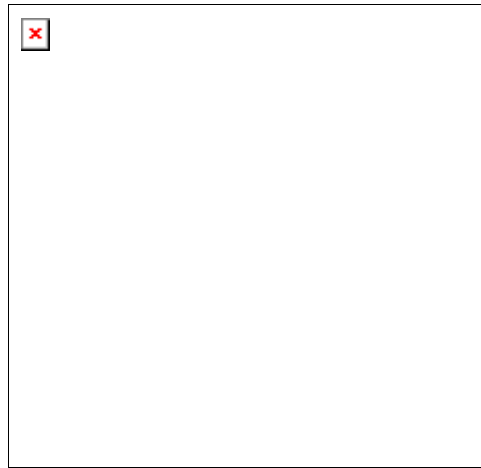

FIG. 11.3

**Adjustment to be made at the time of installing SW BRACKET A**

1. Shift to the first or second gear.
2. At this time, secure SW bracket A with 2 screws in a manner so that the SW attached to SW Bracket A is caused to be ON.

---

[\[Table of Contents\]](#) [\[Previous Page\]](#) [\[Next Page\]](#)

---

### 11-3 GREASING

Apply grease to the following points once every 3 months as a standard. Also, note that RUBBER RING 70 is not of an oil-resistant type and is susceptible to a quality deterioration if oil attaches. Make sure that grease and any other type of oil do not adhere to it.

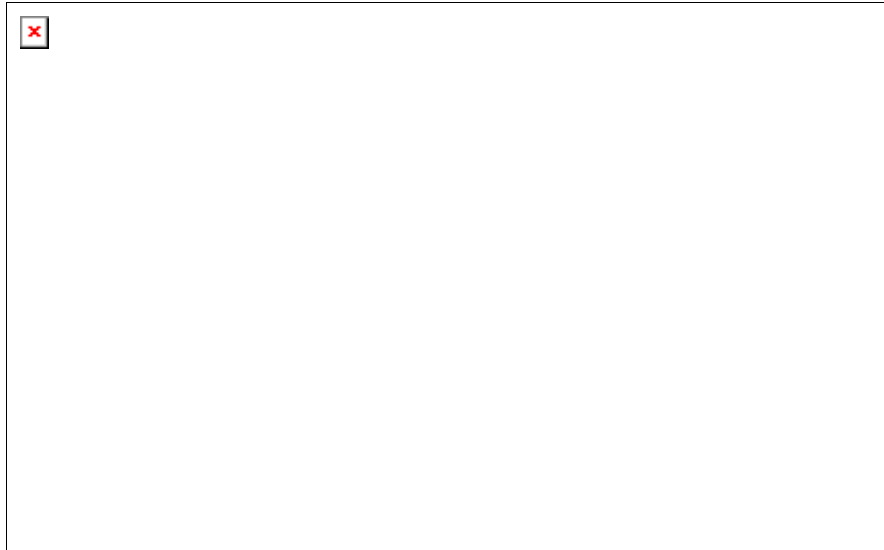

FIG. 11.4

### 11-4 REPLACEMENT OF RUBBER STOPPERS

Once every 6 months as a standard, check to see if any damage is caused to the rubber stoppers. If they are damaged, replace them with the spare parts in the procedure shown in the FIG. below.

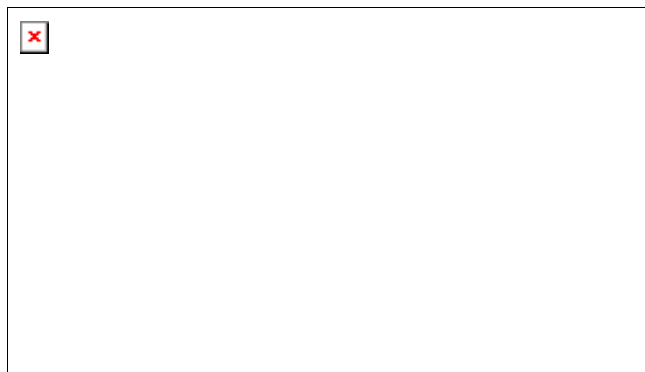

FIG. 11.5

---

[\[Table of Contents\]](#) [\[Previous Page\]](#) [\[Next Page\]](#)

---

## **12. COIN SELECTOR**

### **HANDLING THE COIN JAM**

Even when the REJECT button is pressed, if the coin is not rejected, open the coin chute door and open the selector gate. After removing the jammed coin, put a normal coin in and check to see that the selector correctly functions.

### **CLEANING THE COIN SELECTOR**

1. Turn the power for the machine OFF. Open the coin chute door.
2. Open the gate and dust off by using a soft brush (made of wool, etc.).
3. Remove stain by wiping with a soft cloth which contains water or chemicals detergent.
4. Remove the CRADLE. When removing the retaining ring (E ring), be very careful so as not to bend the shaft.
5. Remove stain from the shaft and pillow portions by wiping off with a soft cloth, etc.
6. After wiping off as per 5 above, further apply a dry cloth, etc. to cause the coin selector to dry completely.

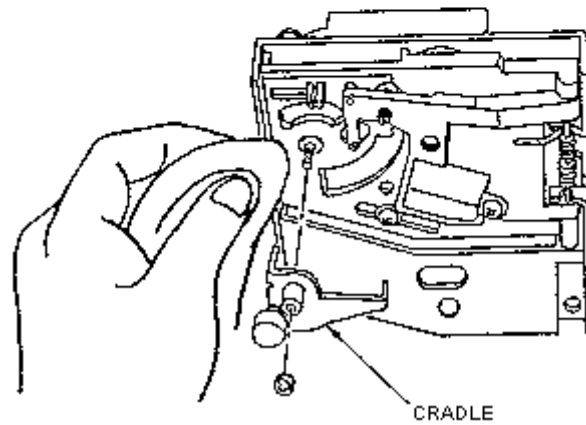
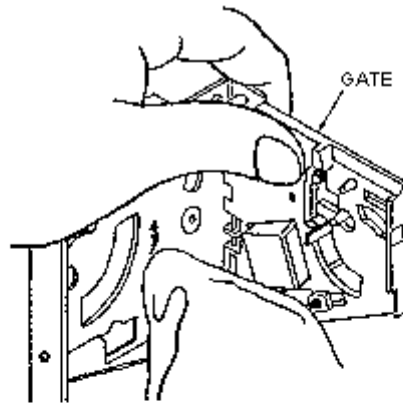

**NOTE:**

Absolutely do not apply machine oil, etc. to the coin selector.

After cleaning the coin selector, insert a regular coin in the normal working status and ascertain that the selector correctly functions.

---

[\[Table of Contents\]](#) [\[Previous Page\]](#) [\[Next Page\]](#)

---

## 13. PROJECTOR

### CAUTION!

- Since the Projector screen is susceptible to damage, pay careful attention to its handling. When cleaning, refrain from using water or volatile chemicals.
- Since the Projector has been adjusted at the time of shipment, avoid making further adjustments without good reason.

Fine adjustments are stored in the Projector. Pressing the Fine Adjustment SW (Convergence Adjustment) results in entering the Fine Adjustment mode, and this may cause the stored fine adjustment to be changed. During work other than for adjustment, should you touch the Fine Adjustment SW by mistake, immediately turn the power off by using the main SW and then turn it back on again. If any distortion or color deviation is found in the test mode and adjustments are needed, use the specified Adjustment knob, or perform the adjustment by remote control. Note that there are two PROJECTOR makes (HITACHI & MITSUBISHI) and the adjustment method is different between the two. When checking the Adjustment Control knob, remove the PTV's Service Door. For the HITACHI Projector, open the cover in front of the control panel. For the MITSUBISHI Projector, remove the cover.

### 13-1 CLEANING THE SCREEN

When the screen surface becomes dirty with dust, etc., clean it by using a soft cloth such as gauze. When water, and volatile chemicals such as benzene, thinner, etc., spill on the screen surface, it may be subject to damage, therefore, do not use them. Also, since the surfaces are susceptible to damage, refrain from rubbing them with a hard material or using a duster.

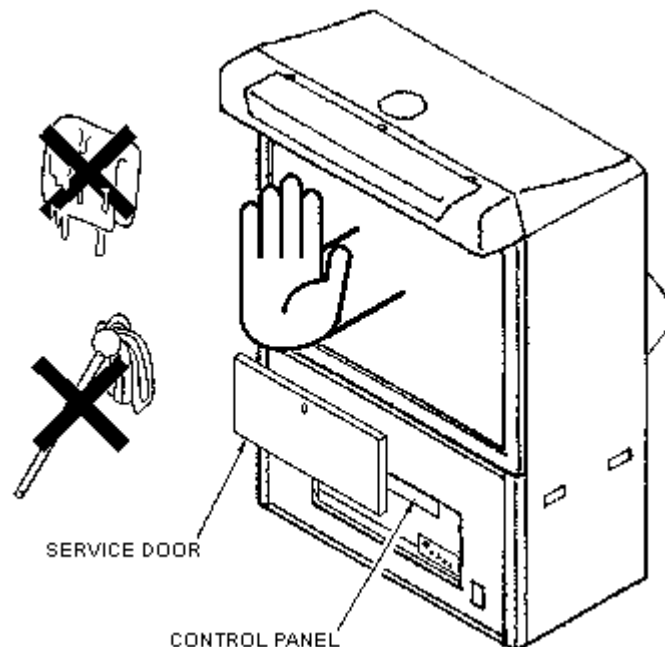



---

[\[Table of Contents\]](#) [\[Previous Page\]](#) [\[Next Page\]](#)

---

## 13-2 HITACHI PROJECTOR

### HITACHI PROJECTOR CONTROL PANEL

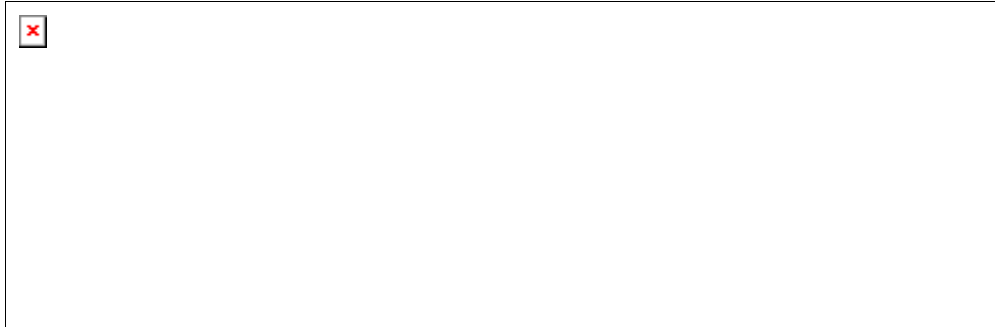

#### STATIC CONVERGENCE ADJUSTMENT

NOTE: Do not touch the right-hand side Convergence Adjustment SW. This SW is used for dynamic convergence adjustment which is rather complicated and the adjustment's visual effect is almost unnoticeable. Therefore, explanations thereof are not given in this

1. Press the left-hand side Convergence Adjustment SW to cause the cross pattern to appear on to the screen.
2. Use the remote control to make static adjustment.

Remote control [2], [5]	Causes the red horizontal line to match with the green horizontal line.
Remote control [4], [6]	Causes the red vertical line to match with the green vertical line.
Remote control [8], [11]	Causes the blue horizontal line to match with the green horizontal line.
Remote control [10], [12]	Causes the blue vertical line to match with the green vertical line.

1. Press the left-hand side Convergence Adjustment SW. At this time, static adjustment results are written and the PTV screen will return to the original screen mode.

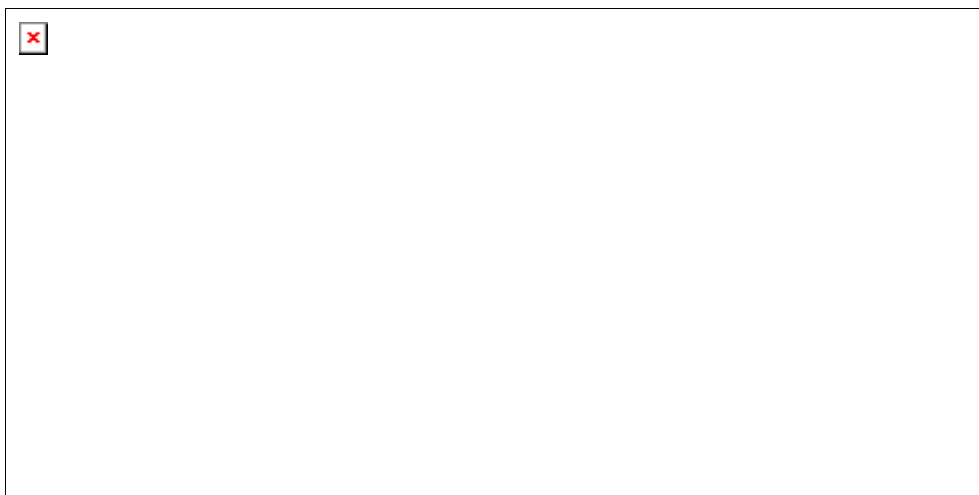

[\[Table of Contents\]](#) [\[Previous Page\]](#) [\[Next Page\]](#)

## 13-3 MITSUBISHI PROJECTOR

### MITSUBISHI PROJECTOR CONTROL PANEL

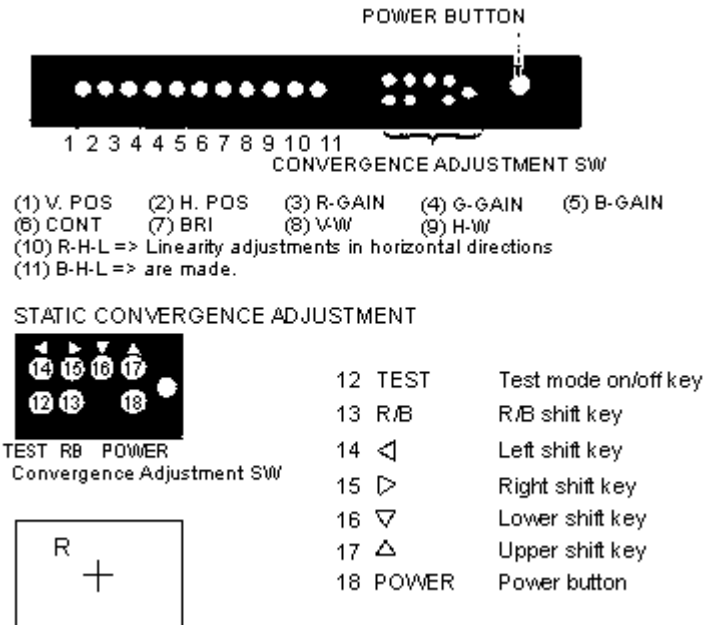

1. For the Convergence adjustment mode, press the test mode on/off key (12).
2. Ensure that "R" is displayed on the screen.
3. Make adjustment so as to cause the red cross pattern to match with the green cross pattern by using Left shift key (14), Right shift key (15), Lower shift key (16), and Upper shift key (17).
4. By using R/B shift key (13), cause the red adjustment "R" to shift to blue adjustment "B" and make sure that "B" is displayed on the screen.
5. In the same manner as in (3) above, cause the blue cross pattern to match with the green cross pattern.
6. After making adjustment, press the test mode on/off key (12) to cancel the Convergence adjustment mode.

[\[Table of Contents\]](#) [\[Previous Page\]](#) [\[Next Page\]](#)

## 14. REPLACING THE FLUORESCENT LAMP

In a manner as shown below, remove the parts and replace the fluorescent lamp.

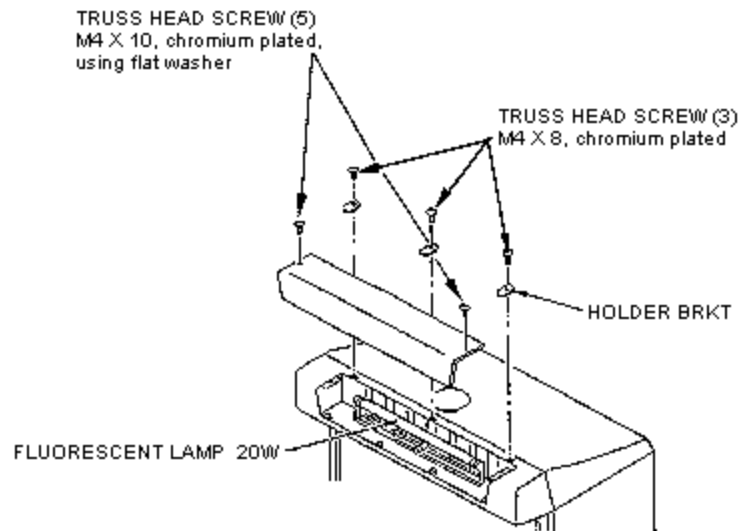

FIG. 14

## 15. PERIODIC CHECK

The items listed below require periodic check and maintenance to retain the performance of this machine and to ensure safe business operation.

	Item	Interval	Reference
CONTROL PANEL	Check lamp.	Monthly	8
	Check VOLUME VALUE.	Monthly	6, 8
	Check ADJUST GEAR engagement.	Trimonthly	9-1
	Greasing of GEAR and bearing.	Trimonthly	9-2
ACCEL. & BRAKE	Check VOLUME VALUE.	Monthly	6, 8
	Check ADJUST GEAR engagement.	Trimonthly	10-1
	Greasing of GEAR and bearing.	Trimonthly	10-2
4 SPEED SHIFTER	Check SW.	Monthly	6, 8
	Greasing of bearing.	Trimonthly	11-3
	Check RUBBER STOPPERS.	Semi-yearly	11-4
FRONT CABI	Check COIN SW.	Monthly	8
	Cleaning of COIN SELECTOR.	Trimonthly	12
PROJECTOR	Check adjustments.	Monthly	6, 8, 13
GAME BD	MEMORY TEST.	Monthly	8
	Check settings.	Monthly	8

[\[Table of Contents\]](#) [\[Previous Page\]](#) [\[Next Page\]](#)

## 16. TROUBLESHOOTING

In case a problem occurs, first check wiring connector connections.

PROBLEMS	CAUSE	COUNTERMEASURES			
When the main power is not on, the machine is not activated.	The power is not ON.	Firmly insert the plug into the outlet.			
	Incorrect power source/voltage.	Make sure that the power supply/voltage are correct.			
	AC Unit fuse blown off due to instantaneous overcurrent.	First remove the cause of overcurrent, then replace the fuse (see Sec. 6). <table border="1" style="width: 100%; border-collapse: collapse;"> <tr> <td style="width: 70%;">514-5036-15000 FUSE 6.4 ØX 30 15000mA 125V</td> <td style="width: 30%;">AC100~120V AREA</td> </tr> <tr> <td>514-5037-8000 FUSE 6.4 ØX 30 8000mA 250V</td> <td>AC220~240V AREA</td> </tr> </table>	514-5036-15000 FUSE 6.4 ØX 30 15000mA 125V	AC100~120V AREA	514-5037-8000 FUSE 6.4 ØX 30 8000mA 250V
514-5036-15000 FUSE 6.4 ØX 30 15000mA 125V	AC100~120V AREA				
514-5037-8000 FUSE 6.4 ØX 30 8000mA 250V	AC220~240V AREA				
PTV screen is blackened and the fluorescent lamp does not light up.	Power supply unit fuse blown off due to instantaneous overcurrent.	First remove the cause of overcurrent, then replace the fuse. <table border="1" style="width: 100%; border-collapse: collapse;"> <tr> <td style="width: 70%;">514-5036-10000 FUSE 6.4 ØX 30 10000mA 125V</td> <td style="width: 30%;"></td> </tr> </table>	514-5036-10000 FUSE 6.4 ØX 30 10000mA 125V		
514-5036-10000 FUSE 6.4 ØX 30 10000mA 125V					
PTV screen is all blue.	Defective connections in between each board.	Make sure of correct connections in between each board.			
The color of image on PTV screen is incorrect.	Connector connections are defective.	Check to see if connector connections of RGB and SYNC are correct.			
	Incorrect monitor adjustment.	Make appropriate adjustments (see Sec. 13).			
PTV screen has a color deviation.	Affected by the periphery, such as other machines, location building's steel frames, etc.	Make convergence adjustments (see Sec. 13).			
		Change installation direction/position. Move the other machines which cause the problem.			
Sound is not emitted.	Sound volume adjustment is not correct.	Adjust the SWITCH UNIT's sound adjustment volume (control) (see Sec. 8).			
	Malfunctioning of sound BD and memory.	Perform SOUND TEST (see Sec. 8).			
Control panel and pedal not operable satisfactorily.	V. R. position deviated, or V. R malfunctioning.	Adjust or replace the V. R. (see Sec. 9 & 10).			
	ADJUST GEAR's engagement is not correct.	Adjust the engagement of ADJUST GEAR (see Sec. 9 & 10).			
SHIFT LEVER doesn't operate satisfactorily.	Switch position deviated, or switch malfunctioning.	Adjust or replace the Switch (see Sec. 11). <table border="1" style="width: 100%; border-collapse: collapse;"> <tr> <td style="width: 70%;"></td> <td style="width: 30%;">509-5566 SW MICRO TYPE</td> </tr> </table>		509-5566 SW MICRO TYPE	
	509-5566 SW MICRO TYPE				
Steering Wheel reaction		First turn the power off and then turn it			

strength is insufficient.	POWER ON CHECK not performed correctly.	back on again. Complete the POWER ON CHECK.
	V. R. position deviated, or V. R. malfunctioning.	Adjust or replace the V. R. (see Sec. 9).
	Reaction mecha's secular change.	Change DRIVE BD DIP SW setting (see Sec. 8 & 17).
Fluorescent lamp doesn't light up.	Fluorescent lamp needs replacement.	Replace the fluorescent lamp (see Sec. 14).

---

[\[Table of Contents\]](#) [\[Previous Page\]](#) [\[Next Page\]](#)

---

## **17. GAME BOARD**

### **17-1 REMOVING THE BOARD**

To replace the IC BD (such as Game BD, Drive BD, etc.), or to change DIP SW settings, take out the IC BD by using the following procedure:

1. Turn the MAIN SW off.
2. Unlock and take off the 2 screws to remove the trunk lid.
3. To remove the BUMPER, take off the 2 screws, one each on both sides and unfasten the 2 snap fasteners, one each on both sides from the inside of the rear cabi.
4. Disconnect all of the wiring connectors from the shield case in which the game BD and I/O BD are incorporated.
5. Pull out the base (on which the shield case is mounted) by taking off the 2 screws.
6. Take off the 3 screws and remove the case lid by causing it to slide.
7. Unlock and take off the 2 screws to remove the rear cabi's service door.
8. Disconnect all of the wiring connectors from the SUBELEC unit.
9. SUBELEC unit can be pulled out of the rear cabi by taking off the 2 screws which secure the SUBELEC unit base.

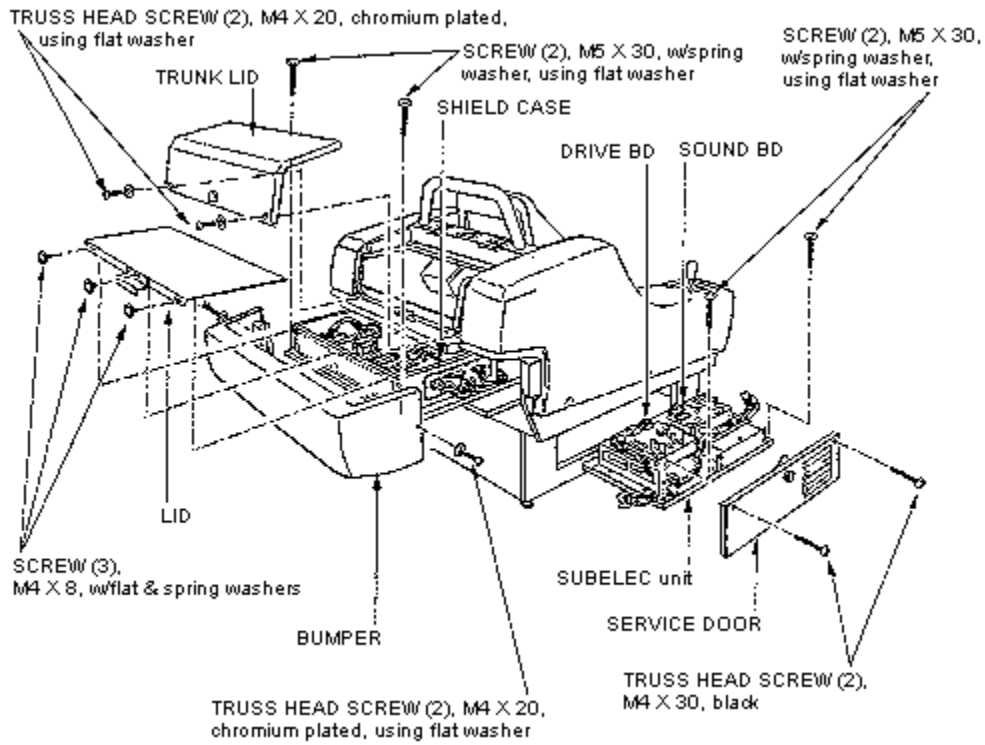

---

[\[Table of Contents\]](#) [\[Previous Page\]](#) [\[Next Page\]](#)

---

## 17-2 COMPOSITION OF GAME BOARD

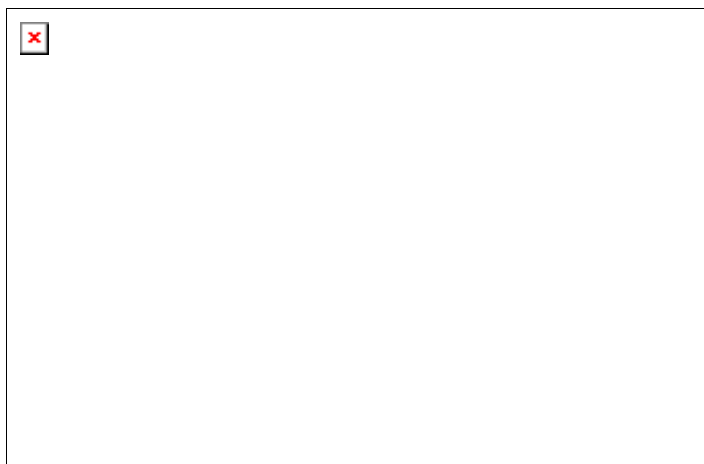

No.	PART No.	DESCRIPTION
1	837-10072	CGT VIDEO BD COM
2	837-10071	CGT CPU BD COM
3	834-10536	ROM BD DAYTONA
4	117-5258	DUMMY BD

## 17-3 INPUT AND OUTPUT RELATIONS

DAYTONA USA DX

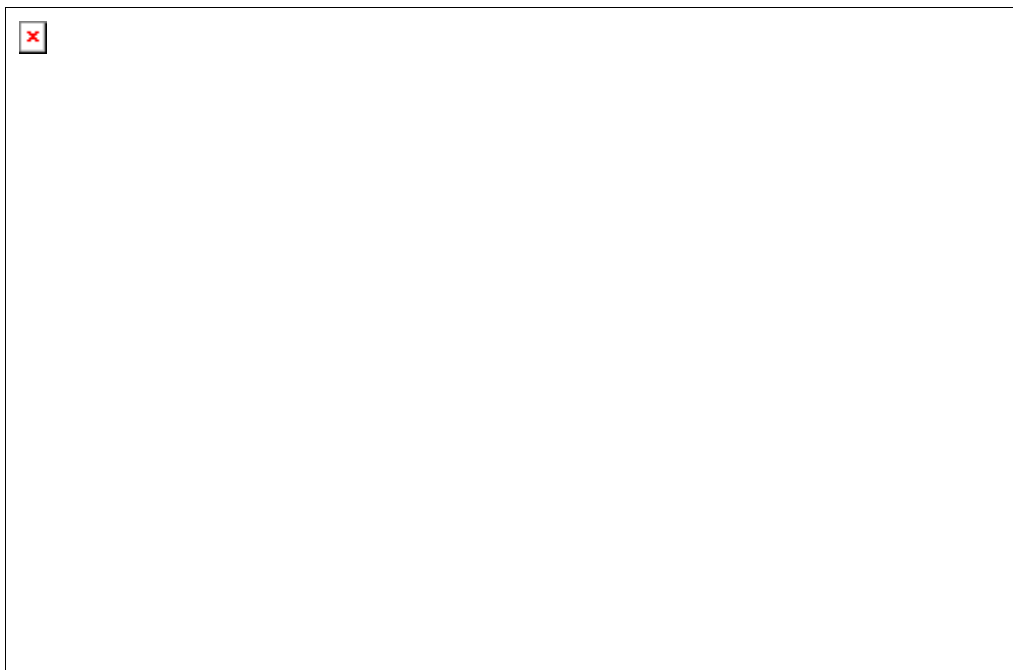



[\[Table of Contents\]](#) [\[Previous Page\]](#) [\[Next Page\]](#)

### 18. DESIGN RELATED PARTS

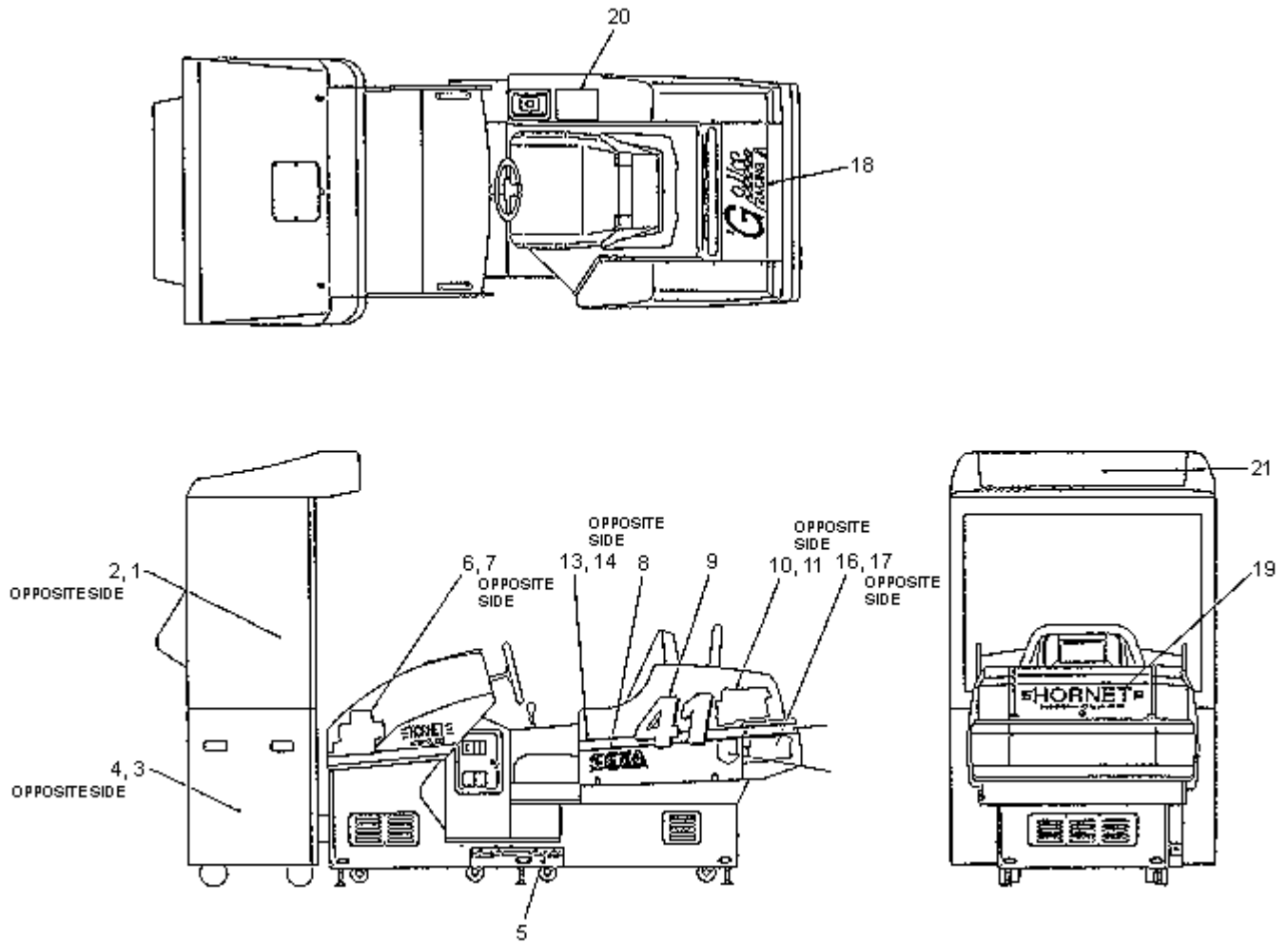

FIG. 18

## Parts Index

(1)	<a href="#">TOP ASSY DAYTONA DX</a>		50
(2)	<a href="#">ASSY PTV</a>	DYN-0500	52
(3)	<a href="#">ASSY BILLBOARD</a>	DYN-0550	54
(4)	<a href="#">ASSY FRONT PANEL</a>	DYN-0600	56
(5)	<a href="#">ASSY MASK</a>	MGL-1150	57
(6)	<a href="#">ASSY FRONT CABINET</a>	DYN-1000	58
(7)	<a href="#">ASSY SUB CABI FRONT</a>	DYN-1001	60
(8)	<a href="#">ASSY FIBER CONNECTOR</a>	DYN-1050	62
(9)	<a href="#">AC UNIT</a>	DYN-1080	63
(10)	<a href="#">ASSY COINCHUTE TOWER</a>	DYN-1100	65
(11)	<a href="#">SW UNIT</a>	DYN-1150	67
(12)	<a href="#">ASSY CONTROL PANEL</a>	DYN-1200	68
(13)	<a href="#">ASSY TWEETER L</a>	DYN-1220	70
(14)	<a href="#">ASSY TWEETER R</a>	DYN-1230	71
(15)	<a href="#">ASSY HANDLE MECHA</a>	DYN-1250	72
(16)	<a href="#">ASSY VIRTUAL BUTTON</a>	DYN-1280	75
(17)	<a href="#">ASSY ACCEL &amp; BRAKE</a>	DYN-1300	76
(18)	<a href="#">ASSY REAR CABINET</a>	DYN-2000	78
(19)	<a href="#">ASSY REAR CABI UPPER</a>	DYN-2100	79
(20)	<a href="#">ASSY SUB CABI REAR U</a>	DYN-2101	81
(21)	<a href="#">ASSY SEAT</a>	DYN-2130	83
(22)	<a href="#">ASSY 4 SPEED SHIFTER</a>	DYN-2150	84
(23)	<a href="#">ASSY REAR SPEAKER</a>	DYN-2190	86
(24)	<a href="#">ASSY REAR CABI LOWER</a>	DYN-2200	87
(25)	<a href="#">ASSY SUB CABI REAR L</a>	DYN-2201	89
(26)	<a href="#">ASSY SHIELD CASE</a>	DYN-2300	91
(27)	<a href="#">ASSY PWR SPLY</a>	DYN-4000	93
(28)	<a href="#">ASSY ELEC</a>	DYN-4100	95

[\[Table of Contents\]](#) [\[Parts Index\]](#) [\[Previous Page\]](#) [\[Next Page\]](#)

# 19. PARTS LIST

## (1) TOP ASSY DAYTONA DX

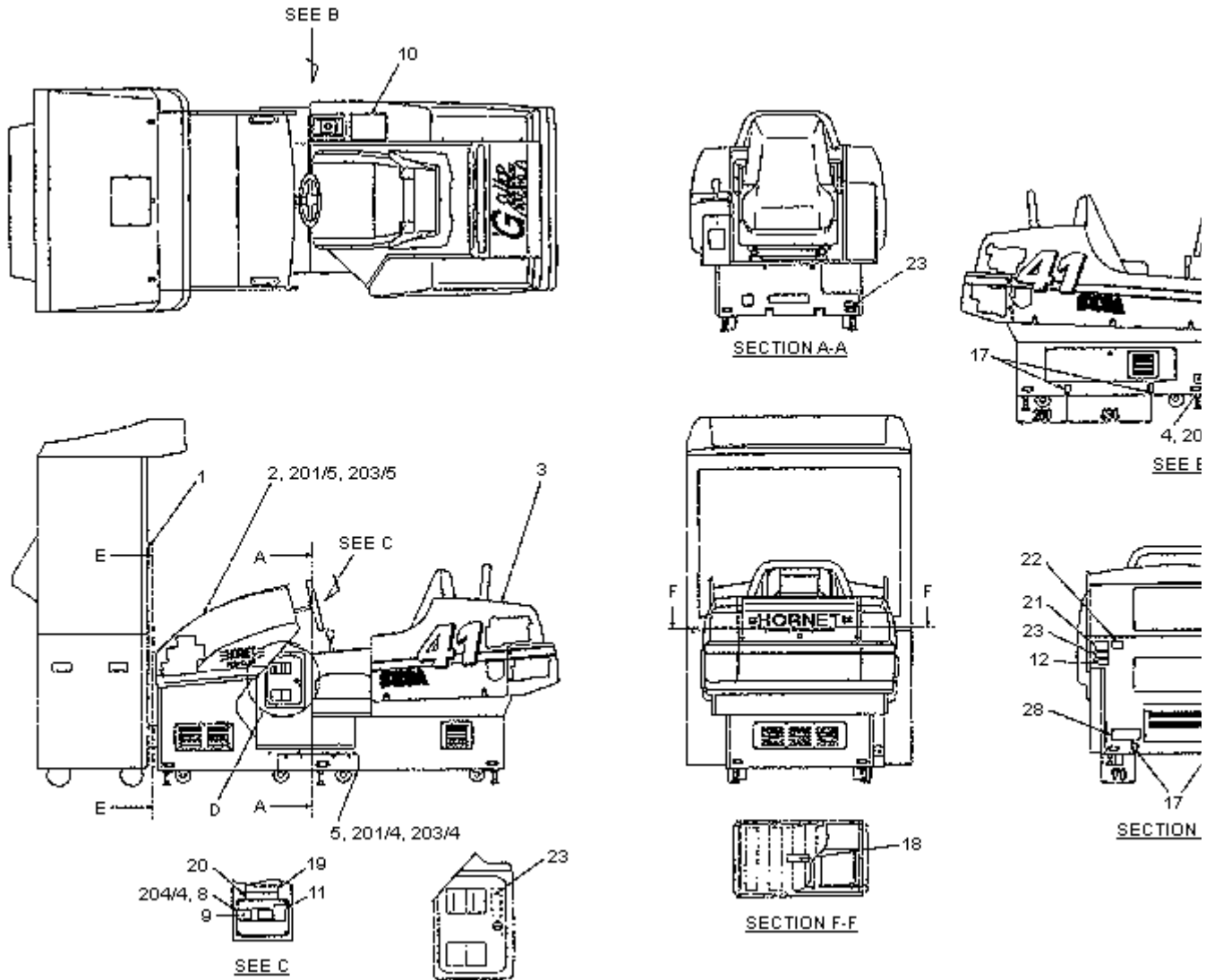

[\[Table of Contents\]](#) [\[Parts Index\]](#) [\[Previous Page\]](#) [\[Next Page\]](#)

**(2) ASSY PTV (DYN-0500)**

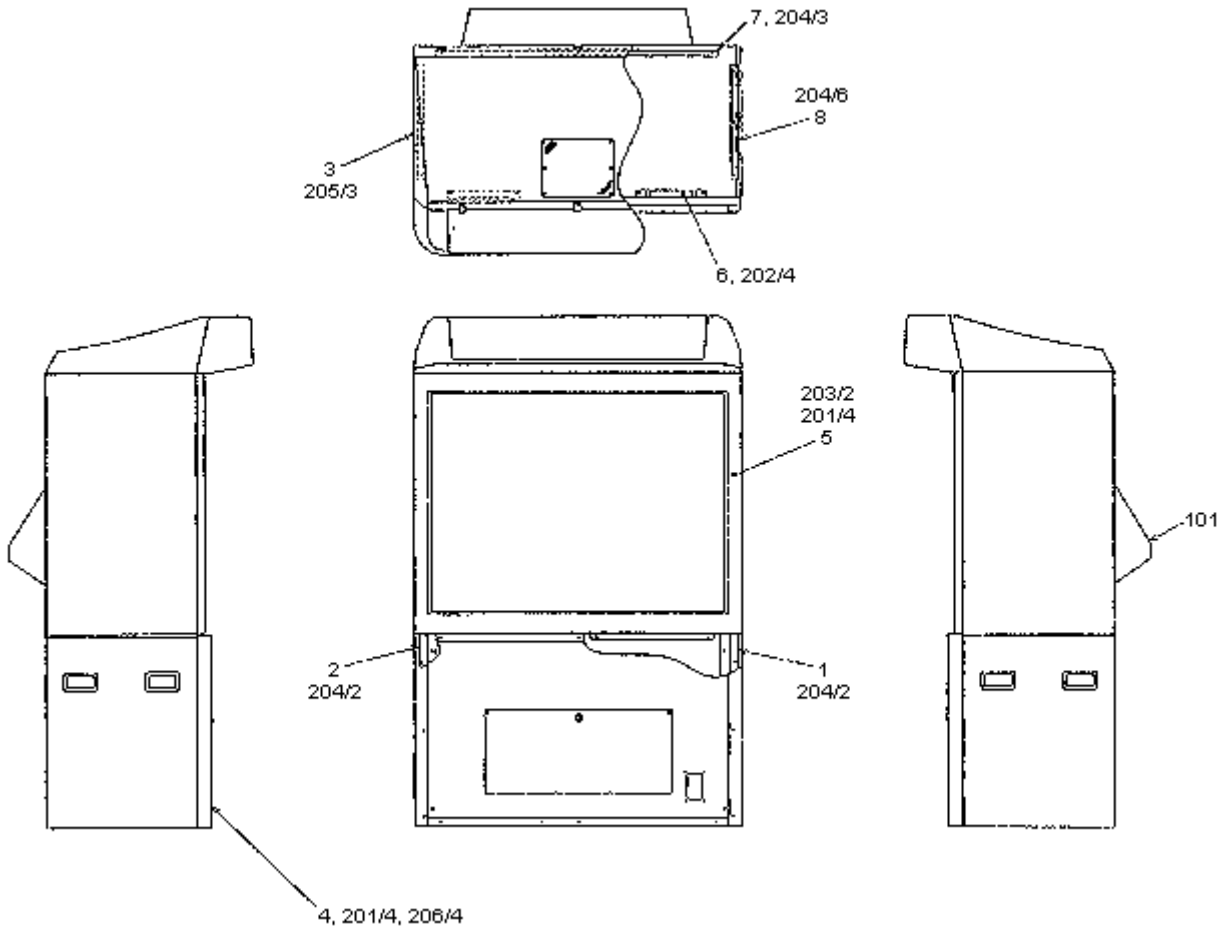

[\[Table of Contents\]](#) [\[Parts Index\]](#) [\[Previous Page\]](#) [\[Next Page\]](#)

### (3) ASSY BILLBOARD (DYN-0550)

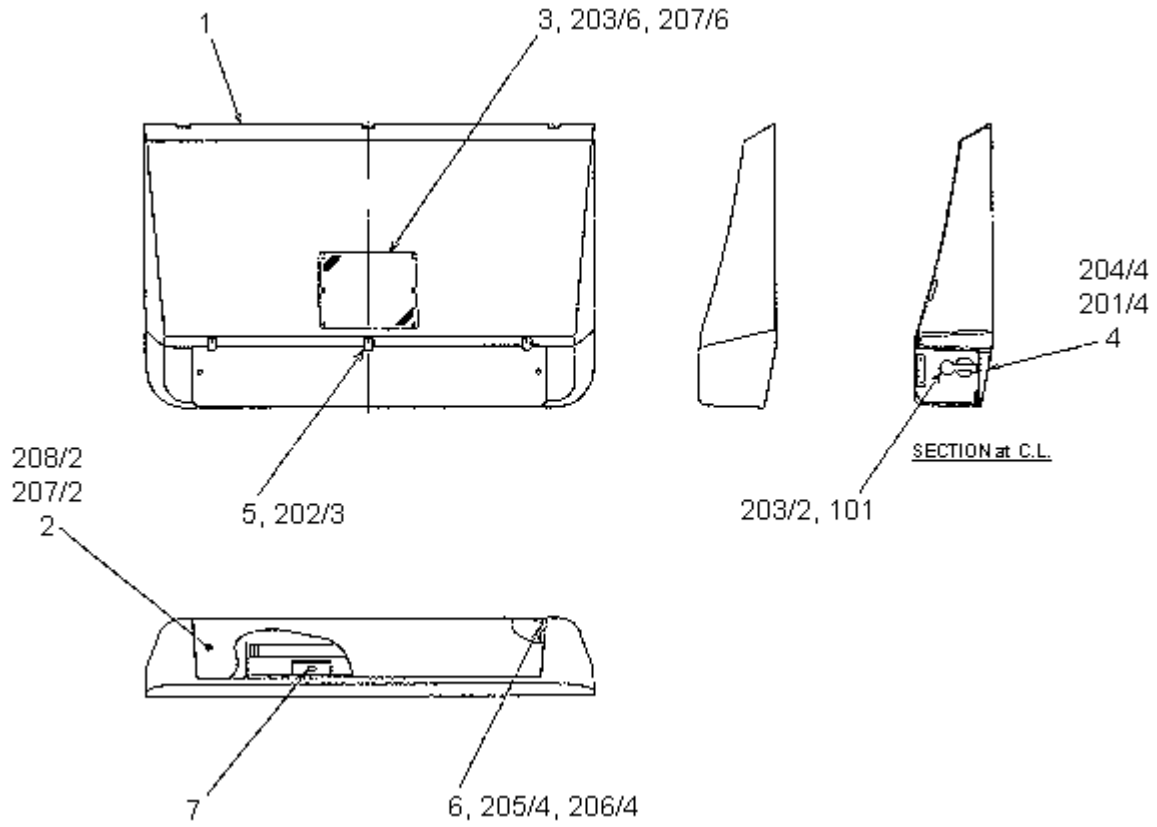

[\[Table of Contents\]](#) [\[Parts Index\]](#) [\[Previous Page\]](#) [\[Next Page\]](#)

#### (4) ASSY FRONT PANEL (DYN-0600)

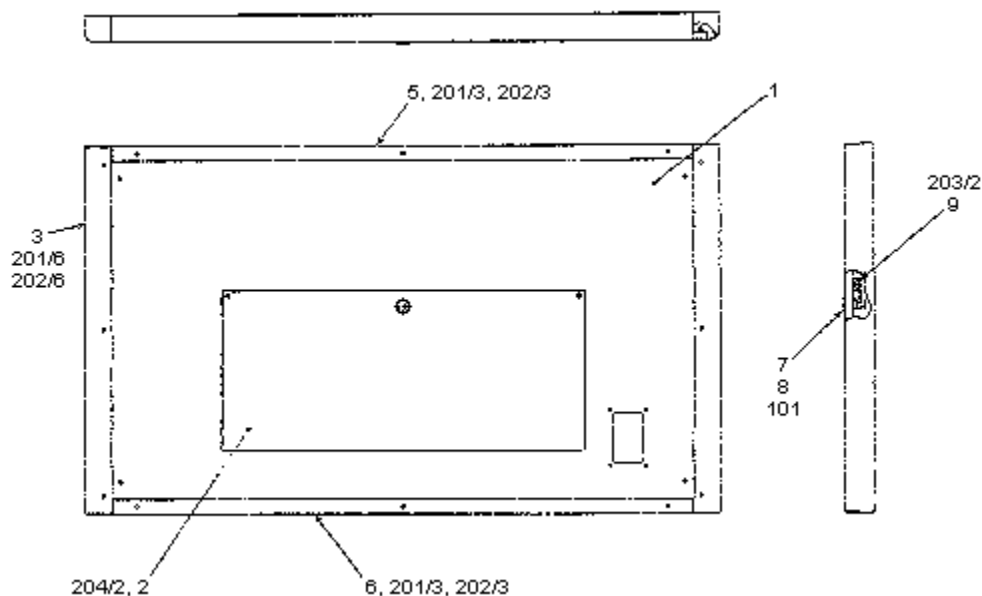

ITEM NO.	PART NO.	DESCRIPTION
1	DYN-0601	FRONT PANEL
2	DYN-0602	SERVICE DOOR
3	DYN-0604	SIDE BRKT
5	DYN-0606	BRKT UPPER
6	DYN-0607	BRKT LOWER
7	DP-1148X	LKG TNG
8	117-0062	PLATE LOCK RETAINER
9	117-5098	TNG RETAINER PLATE
101	220-5380	MAG LOCK MASTER W/O KEY
201	068-552016	FLT WSHR 5.5-20 X 1.6
202	050-F00500	FLG NUT M5
203	011-T00312	TAP SCR TH 3 X 12
204	000-T00430-OC	M SCR TH CRM M4 X 30

[\[Table of Contents\]](#) [\[Parts Index\]](#) [\[Previous Page\]](#) [\[Next Page\]](#)

**(5) ASSY MASK (MGL-1150)**

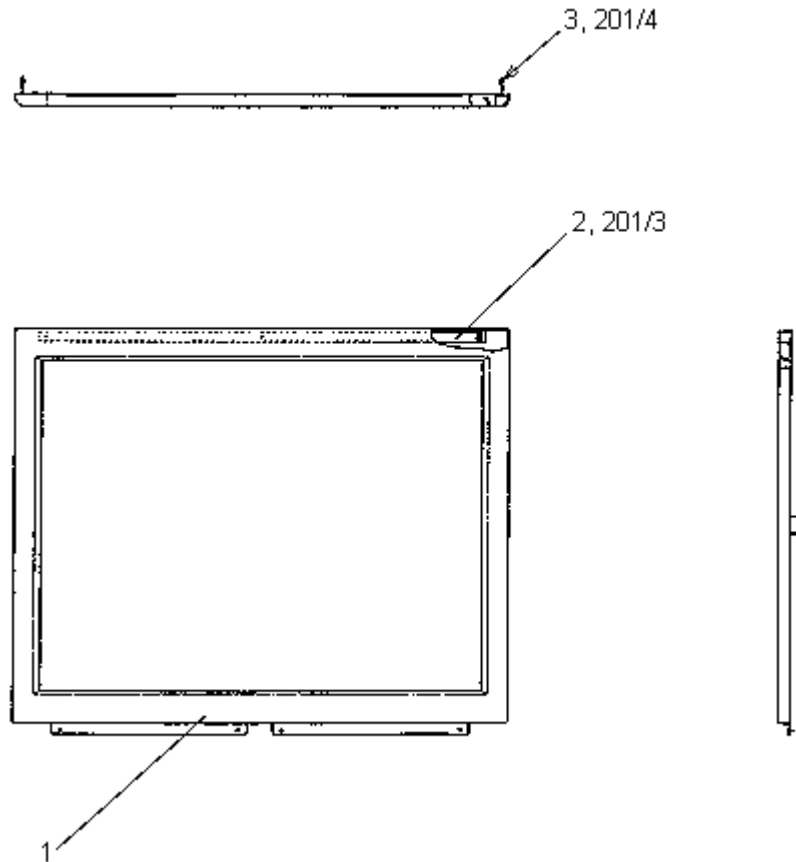

ITEM NO.	PART NO.	DESCRIPTION
1	MGL-1102	TV MASK
2	MGL-1151	SLIT PLATE
3	MGL-1152	MASK SIDE HOLDER
201	012-F00408-OB	TAP SCR FH BLK 4 X 8
202	000-F00410	M SCR FH M4 X 10

[\[Table of Contents\]](#) [\[Parts Index\]](#) [\[Previous Page\]](#) [\[Next Page\]](#)

### (6) ASSY FRONT CABINET (DYN-1000)

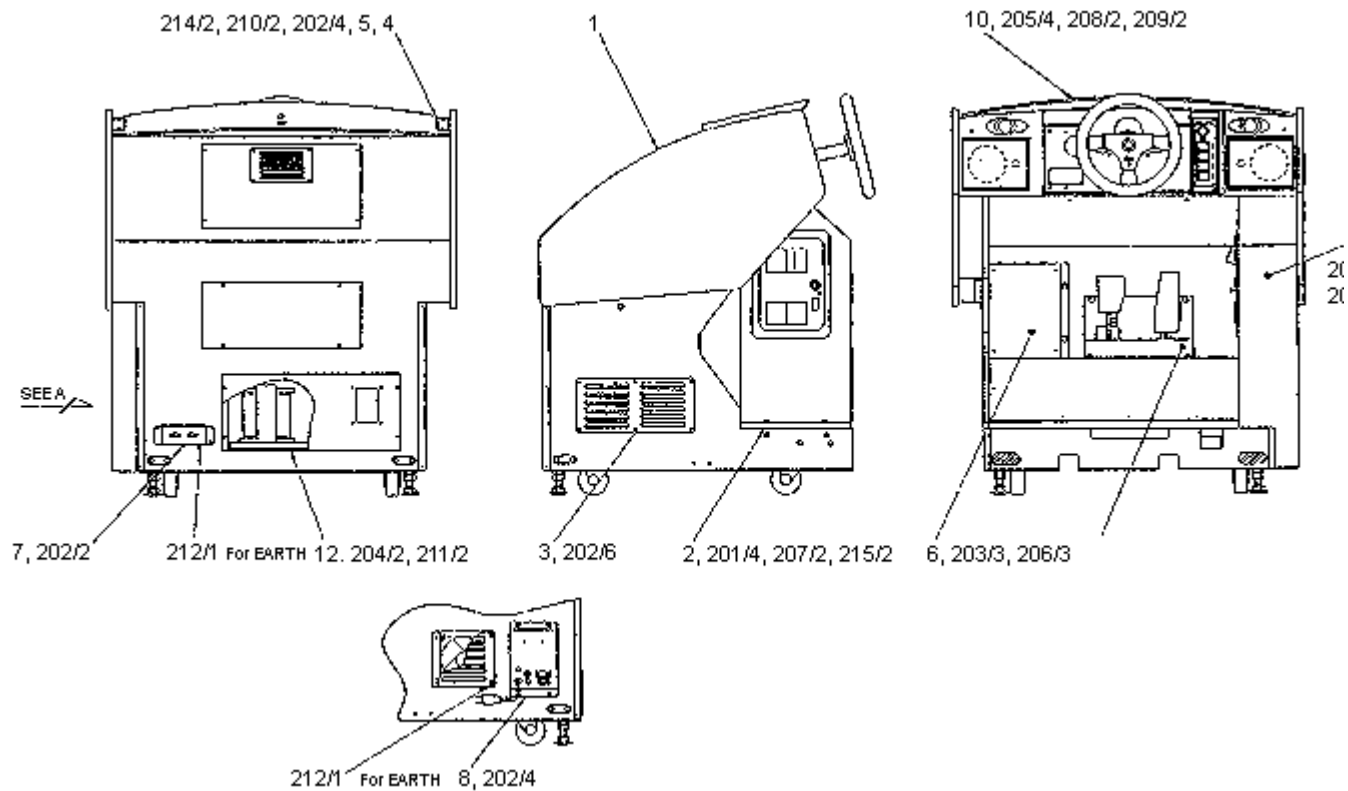



[\[Table of Contents\]](#) [\[Parts Index\]](#) [\[Previous Page\]](#) [\[Next Page\]](#)

**(7) ASSY SUB CABI FRONT (DYN-1001)**

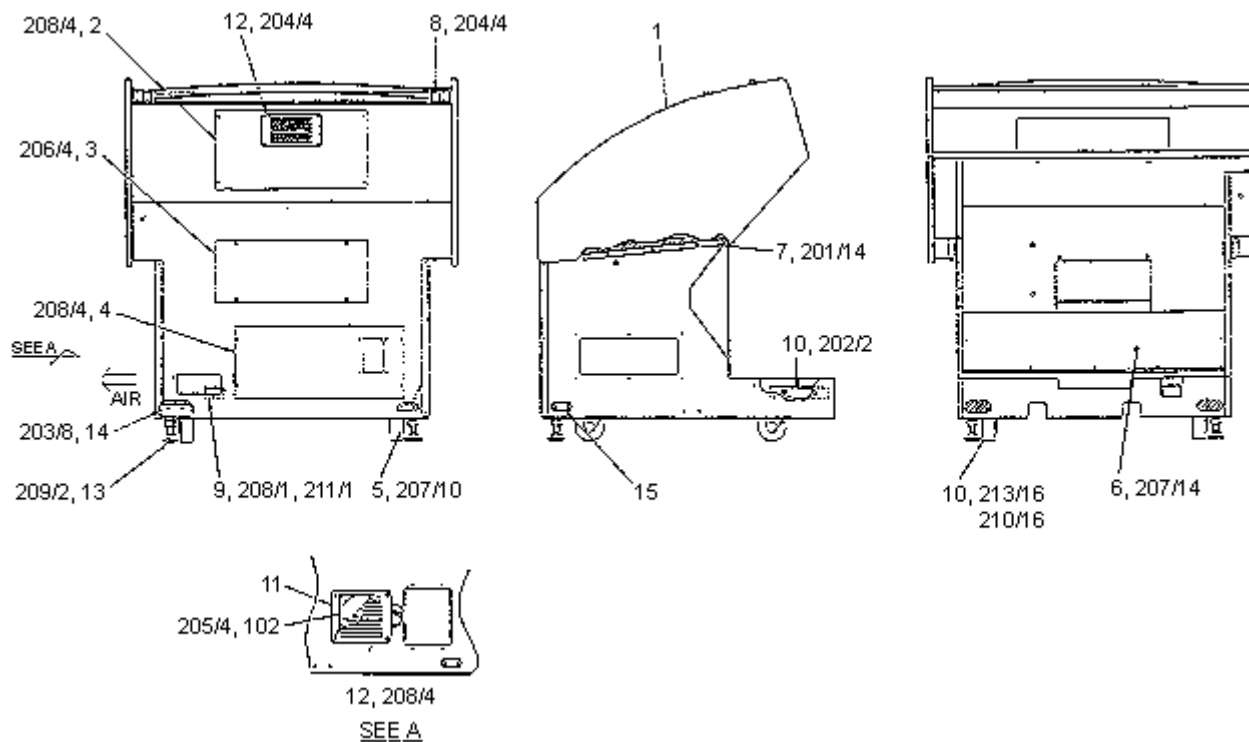

[\[Table of Contents\]](#) [\[Parts Index\]](#) [\[Previous Page\]](#) [\[Next Page\]](#)

**(8) ASSY FIBER CONNECTOR (DYN-1050)**

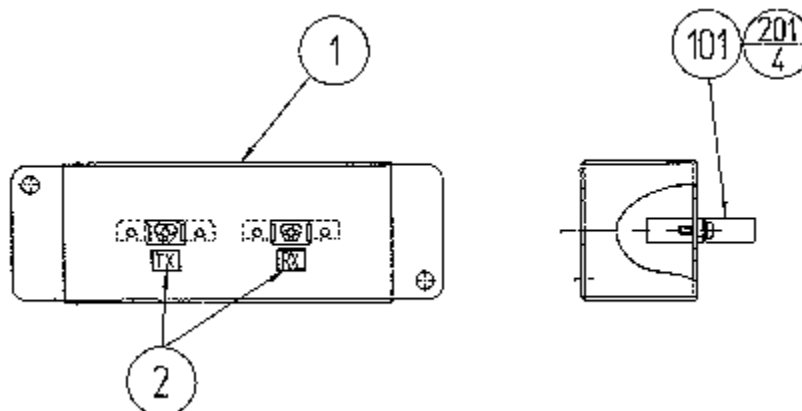

ITEM NO.	PART NO.	DESCRIPTION
1	DYN-1051	OPT CONNECTOR BRKT
2	421-7515	STICKER FIBER CABLE TX/RX
101	211-5479	CONN OPT JOINT
201	000-P00312-W	M SCR PH W/FS M3 X 12

---

[\[Table of Contents\]](#) [\[Parts Index\]](#) [\[Previous Page\]](#) [\[Next Page\]](#)

---

**(9) AC UNIT (DYN-1080)**

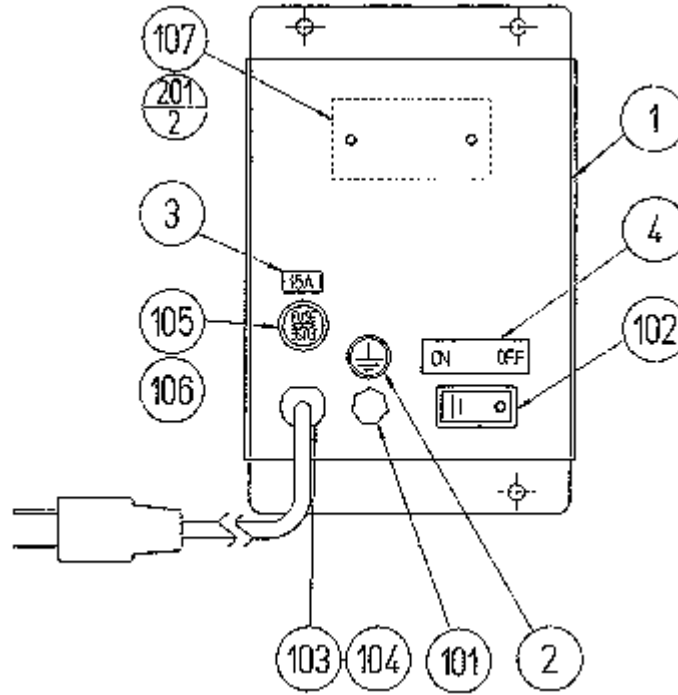

[\[Table of Contents\]](#) [\[Parts Index\]](#) [\[Previous Page\]](#) [\[Next Page\]](#)

**(10) ASSY COINCHUTE TOWER (DYN-1100)**

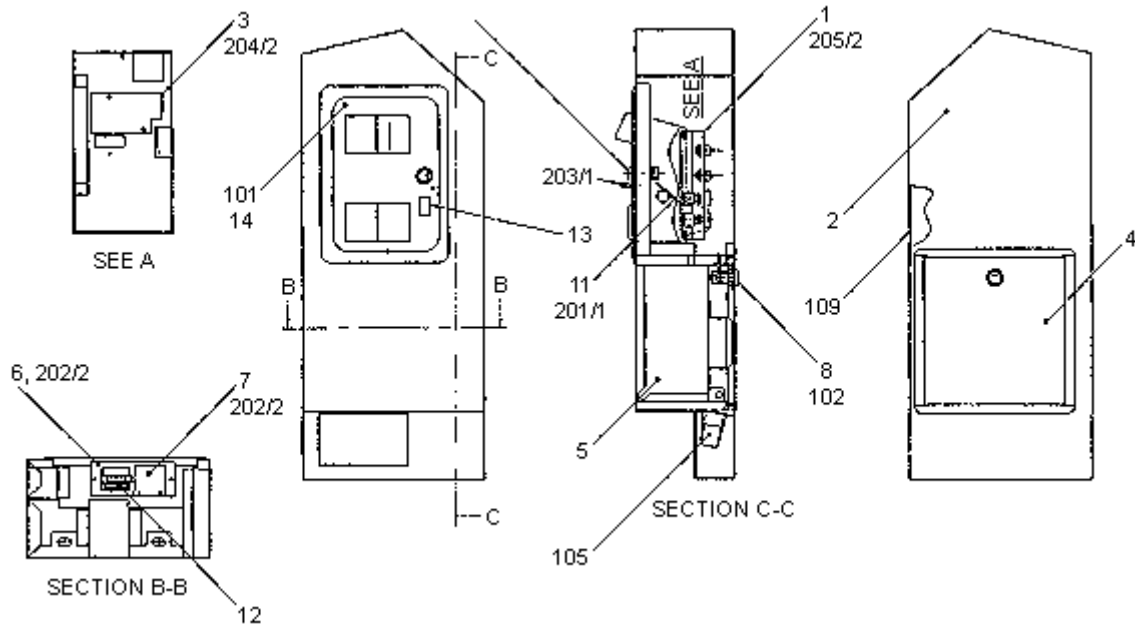

[\[Table of Contents\]](#) [\[Parts Index\]](#) [\[Previous Page\]](#) [\[Next Page\]](#)

**(11) SW UNIT (DYN-1150)**

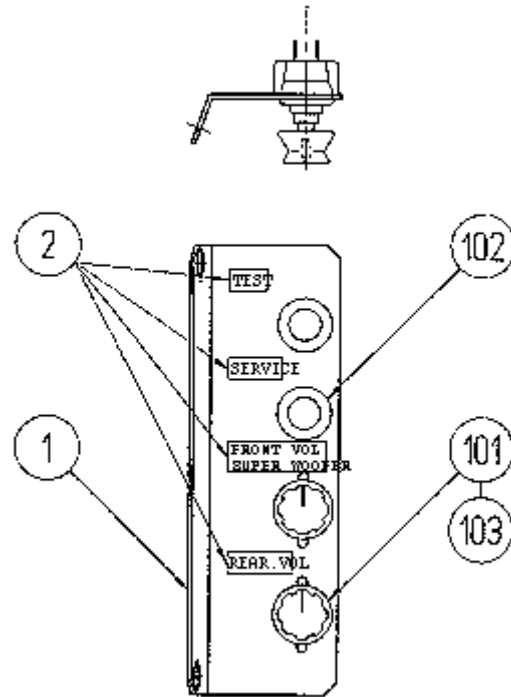

ITEM NO.	PART NO.	DESCRIPTION	NOTE
1	DYN-1151	SW BRACKET	
2	421-8498	STICKER SW UNIT DYN DX	
101	220-5179	VOL CONT B-5K OHM	
102	509-5028	SW PB 1M	
103	601-0042	KNOB 22mm	
104	310-5029-F20	SUMITUBE F F20mm	Ø4
105	601-0460	PLASTIC TIE BELT 100mm	
301	600-6363-70	WIRE HARN SOUND VOL	
302	600-6363-71	WIRE HARN SW UNIT	

[\[Table of Contents\]](#) [\[Parts Index\]](#) [\[Previous Page\]](#) [\[Next Page\]](#)

**(12) ASSY CONTROL PANEL (DYN-1200)**

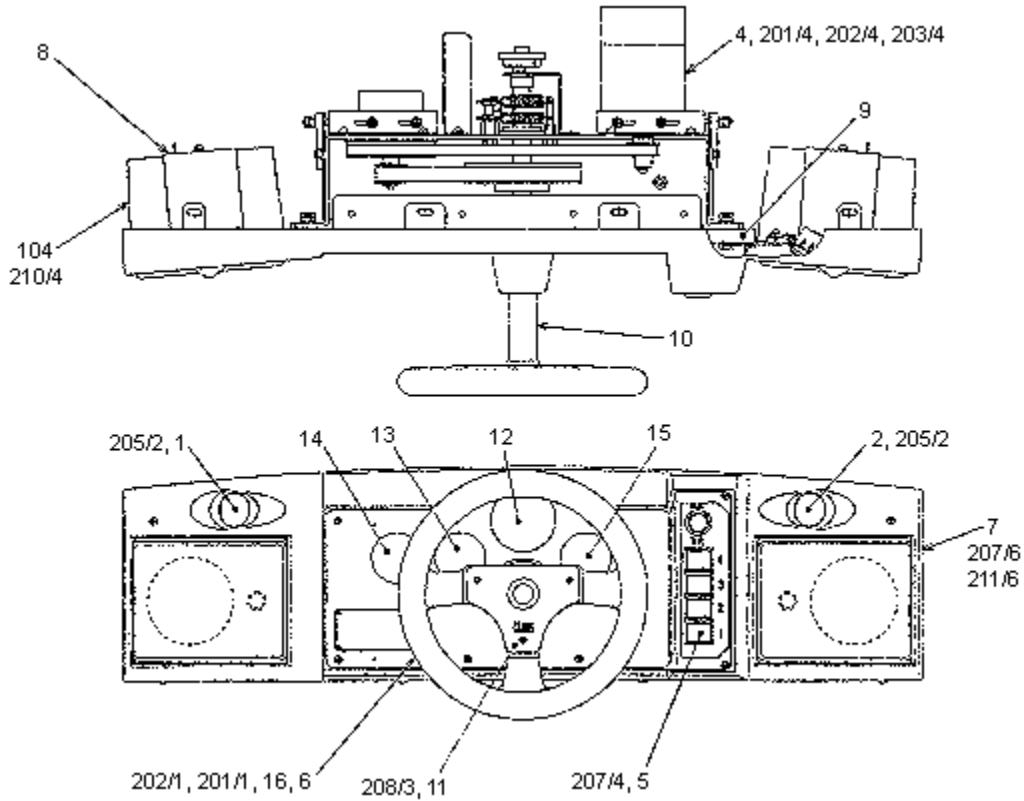

[\[Table of Contents\]](#) [\[Parts Index\]](#) [\[Previous Page\]](#) [\[Next Page\]](#)

### (13) ASSY TWEETER L (DYN-1220)

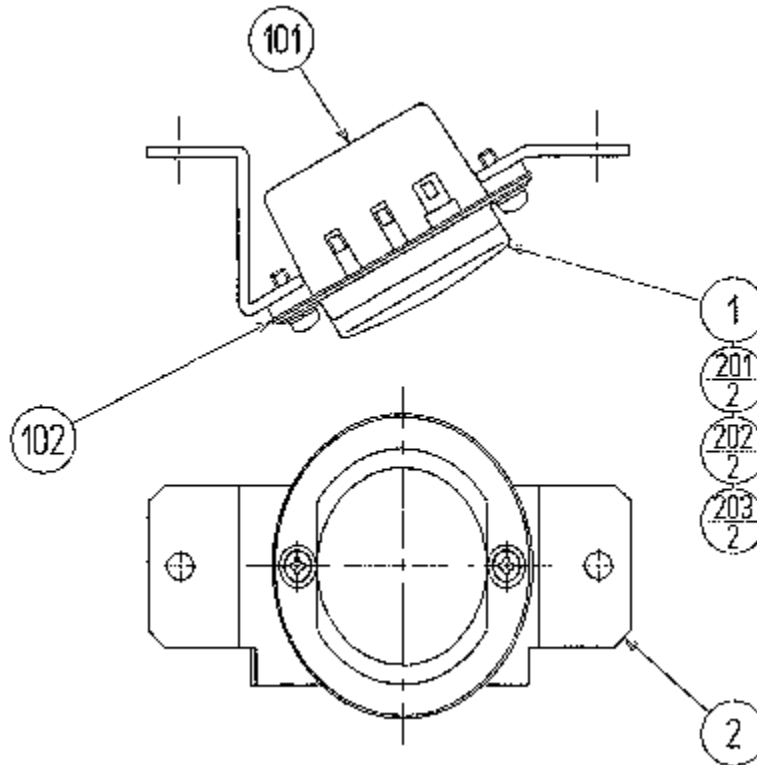

ITEM NO.	PART NO.	DESCRIPTION
1	DYN-1203	TWEETER NET
2	DYN-1206	TWEETER BRKT L
101	130-5112	TWEETER 8 OHM 2W Ø35
102	310-5055	INSULATOR SHEET
201	000-P00310-OB	M SCR PH BLK M3 X 10
202	060-F00300-OB	FLT WSHR BLK M3
203	060-S00300-OB	SPR WSHR BLK M3

[\[Table of Contents\]](#) [\[Parts Index\]](#) [\[Previous Page\]](#) [\[Next Page\]](#)

### (13) ASSY TWEETER R (DYN-1230)

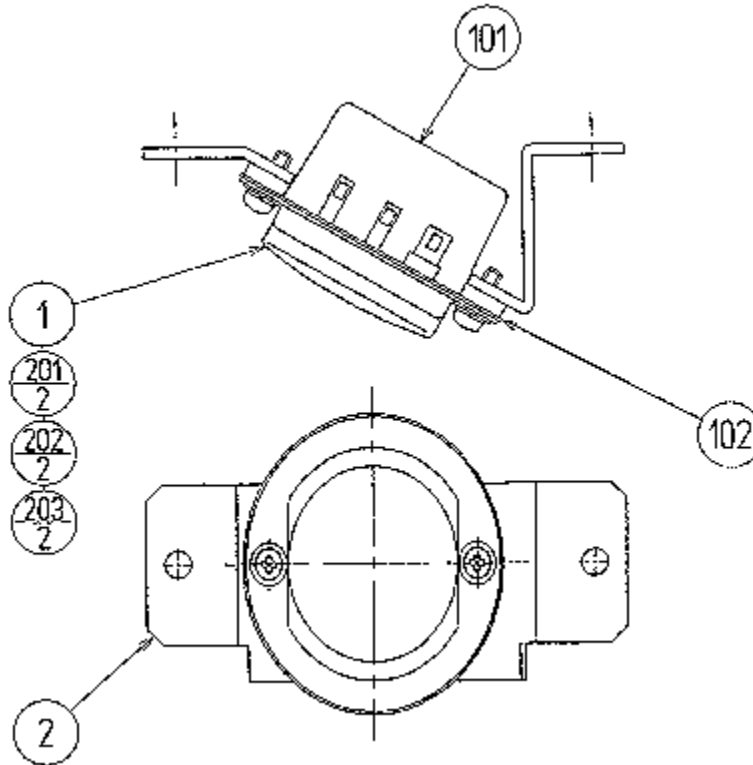

ITEM NO.	PART NO.	DESCRIPTION
1	DYN-1203	TWEETER NET
2	DYN-1206	TWEETER BRKT R
101	130-5112	TWEETER 8 OHM 2W Ø35
102	310-5055	INSULATOR SHEET
201	000-P00310-OB	M SCR PH BLK M3 X 10
202	060-F00300-OB	FLT WSHR BLK M3
203	060-S00300-OB	SPR WSHR BLK M3



[\[Table of Contents\]](#) [\[Parts Index\]](#) [\[Previous Page\]](#) [\[Next Page\]](#)

**(15) ASSY HANDLE MECHA (DYN-1250)**

**ASSY HANDLE MECHA (DYN-1250)**

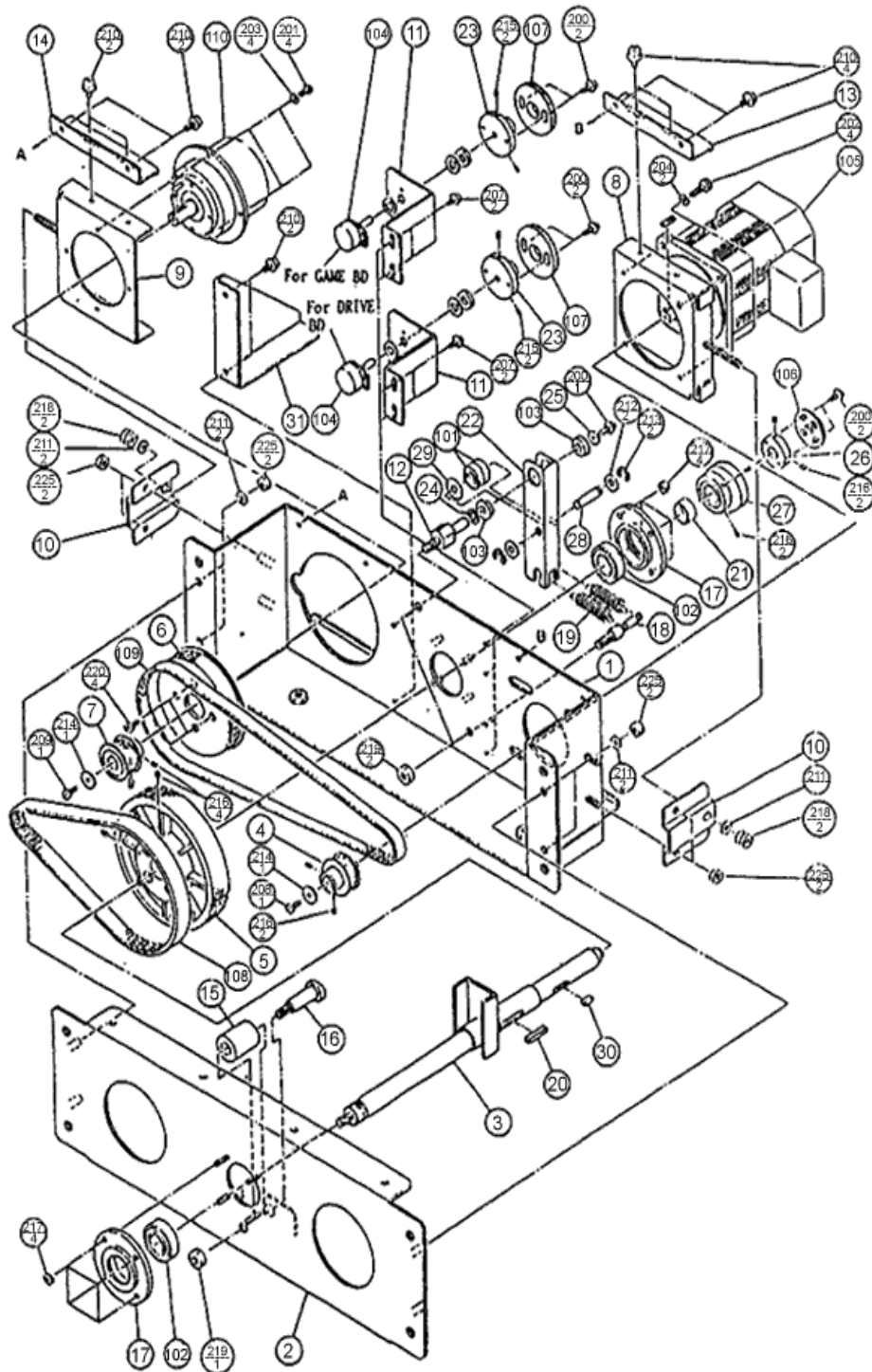

ITEM NO.	PART NUMBER	DESCRIPTION

1	DYN-1251	HANDLE BASE
2	DYN-1252	BASE LID
3	DYN-1253	HANDLE SHAFT
4	DYN-1254	DRIVE PULLEY
5	DYN-1255	HANDLE PULLEY
6	DYN-1256	CLUTCH PULLEY A
7	DYN-1257	CLUTCH PULLEY B
8	DYN-1258	MOTOR BRACKET
9	DYN-1259	CLUTCH BRACKET
10	DYN-1260	TENSIONER BRACKET
11	DYN -1261	VR BRACKET
12	DYN-1262	SWING ARM SHAFT
13	DYN-1263	GUIDE HOLDER A
14	DYN-1264	GUIDE HOLDER B
15	DYN-1265	STOPPER RUBBER
16	DYN-1266	STOPPER BOLT
17	DYN-1267	HOUSING
18	DYN-1268	SPRING HOOK
19	DYN-1269	EXT SPRING
20	DYN-1270	STOPPER KEY
21	DYN-1272	SPACER RING
22	DYN-1273	SWING ARM
23	BVG-1221	GEAR HOLDER
24	BVG-1340	FLT WSHR 8. 1-12X2
25	BVG-1341	FLT WSHR 4. 1-12X2
26	SLC-1130	ADJUST RING
27	SLC-1141-X	WHITE CAM
28	SOR-2112	BEARING SHAFT
29	SOR-2113	SPACER
30	SOR-2115	KEY 5X10
31	DYN-1274	GUARD BRACKET
101	100-5018	BALL BEARING DIA 8 (NSK 608ZZ)
102	100-5112	BEARING DIA 17 (NSK 6003ZZ)
103	100-5041	BEARING (NSK F688ZZ)
104	220-5373	VOL CONT B-5K OHM
104	220-5484	VOL CONT B-5K OHM
105	350-5235	MOTOR AC100V 1250/1550 RPM W/H
105	350-5295	MOTOR AC100V 60W

106	601-6172	GEAR 48
107	601-6959	GEAR 64
108	601-7847	TIMING BELT (150 5M 550)
109	601-7488	TIMING BELT (100 5M 750)
110	601-7849	PARTICLE CLUTCH BRAKE
111	310-5029-F20	SUMITUBE F F20MM
112	601-0460	PLASTIC TIE BELT 100MM
114	209-0023	CONN CLOSED END
201	020-000410-HZ	HEX SKT CAP SCR BLK 0Z M4X10
202	020-000512-HZ	HEX SKT CAP SCR BLK 0Z M5X12
203	060-S00400	SPR WSHR M4
204	060-S00500	SPR WSHR M5

[\[Table of Contents\]](#) [\[Parts Index\]](#) [\[Previous Page\]](#) [\[Next Page\]](#)

### (16) ASSY VIRTUAL BUTTON (DYN-1280)

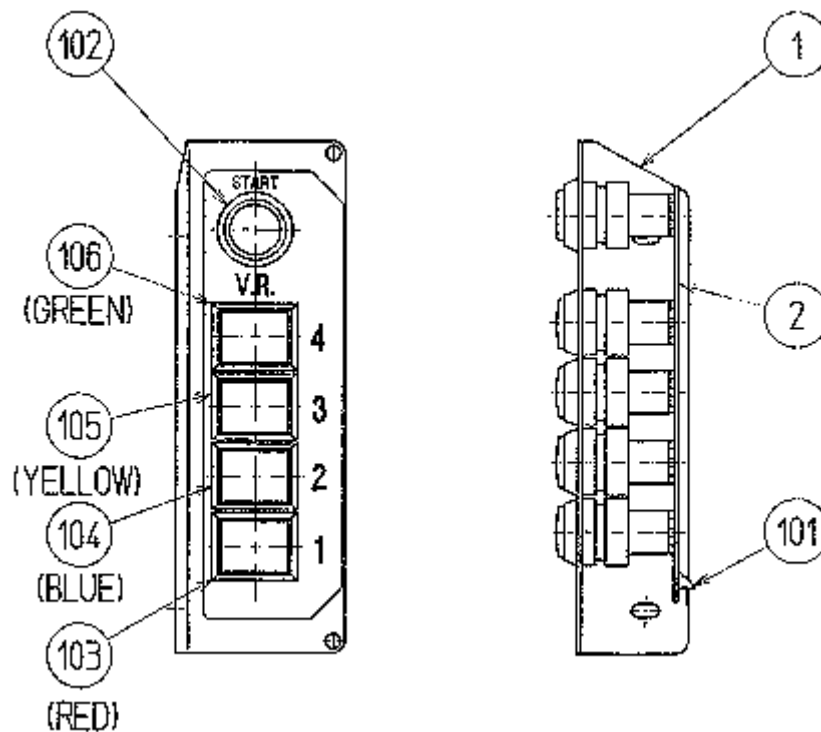

ITEM NO.	PART NO.	DESCRIPTION
1	DYN-1231	VR SW BRKT
2	171-647SB	PC BD LIGHTING SW x 5
101	212-5205-12	CONN JST M 12P RTA
102	509-5560-Y	PB SW W/L 6V 1L Y
103	509-5561-R	PB SW W/L 6V 5L R
104	509-5561-S	PB SW W/L 6V 5L S
105	509-5561-Y	PB SW W/L 6V 5L Y
106	509-5561-G	PB SW W/L 6V 5L G

[\[Table of Contents\]](#) [\[Parts Index\]](#) [\[Previous Page\]](#) [\[Next Page\]](#)

**(17) ASSY ACCEL & BRAKE (DYN-1300)**

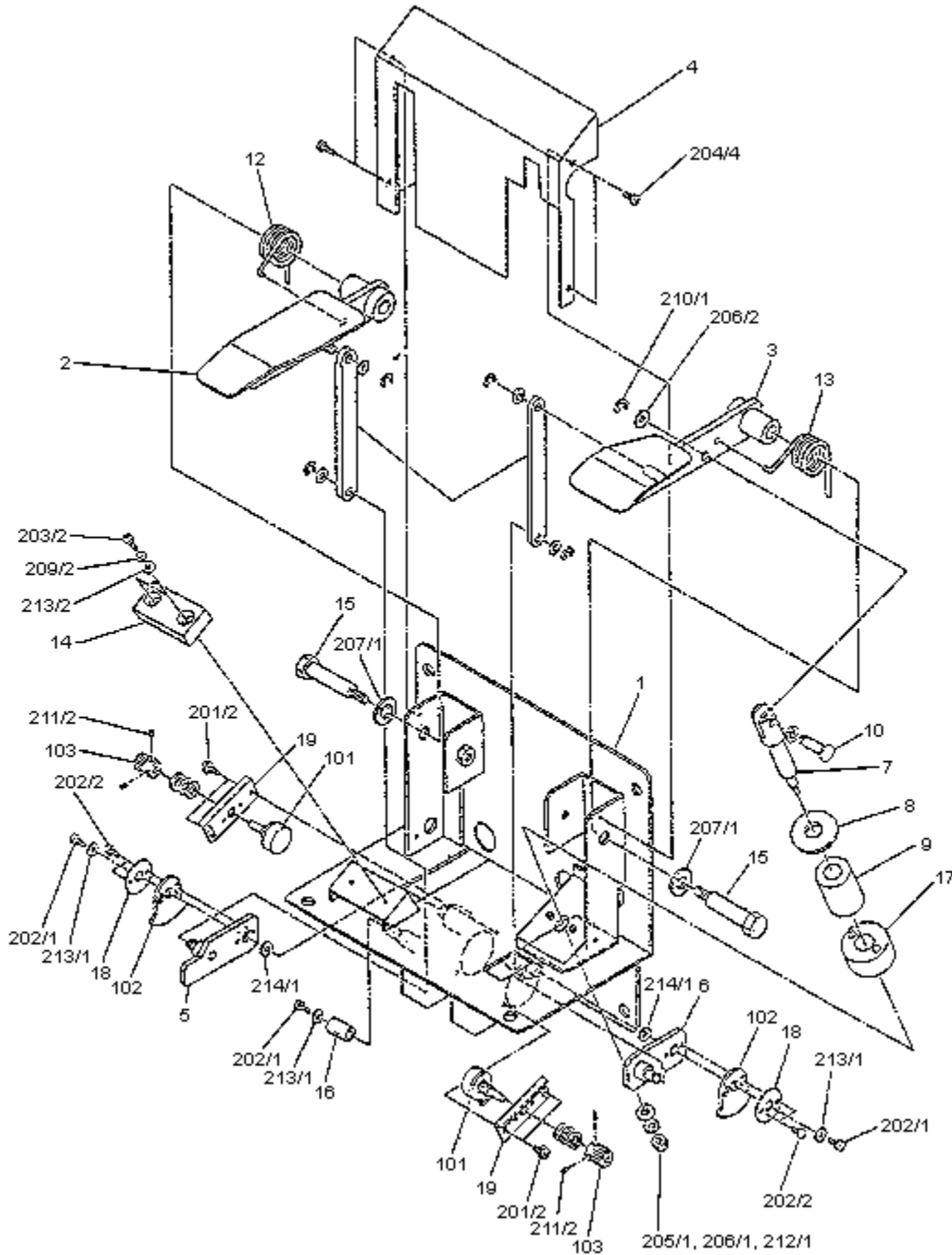

[\[Table of Contents\]](#) [\[Parts Index\]](#) [\[Previous Page\]](#) [\[Next Page\]](#)

### (18) ASSY REAR CABINET (DYN-2000)

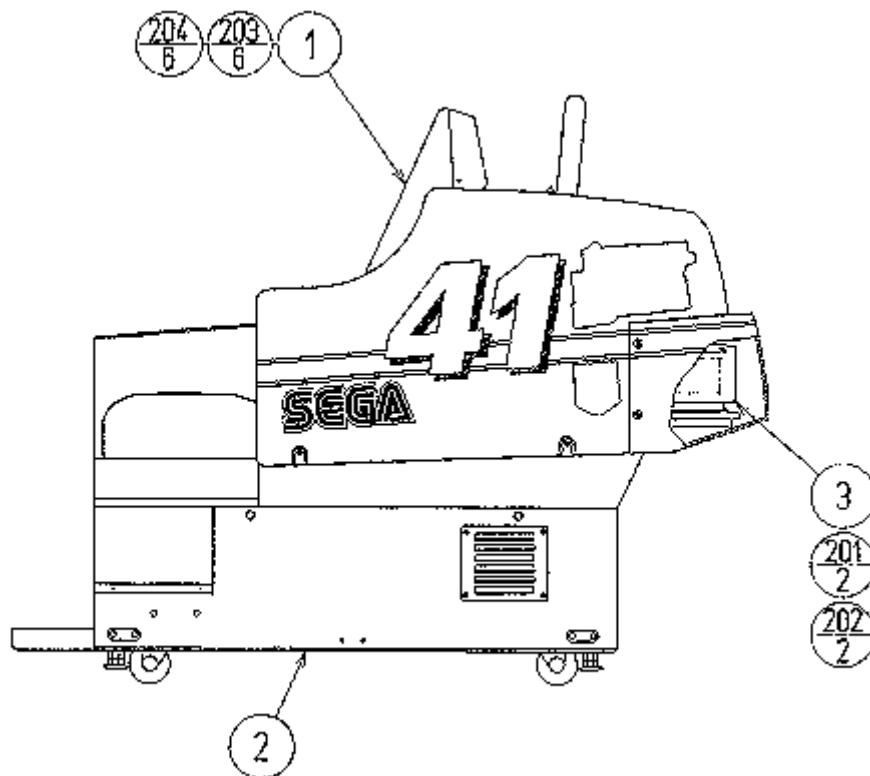

ITEM NO.	PART NO.	DESCRIPTION
1	DYN-2100	ASSY REAR CABI UPPER
2	DYN-2200	ASSY REAR CABI LOWER
3	DYN-2300	ASSY SHIELD CASE
201	000-P00530-S	M SCR PH W/S M5 X 30
202	068-552016	FLT WSHR 5.5-20 X 1.6
203	030-000850-SB	HEX BLT W/S BLK M8 X 50
204	068-852216-OB	FLT WSHR BLK 8.5-22 X 1.6

[\[Table of Contents\]](#) [\[Parts Index\]](#) [\[Previous Page\]](#) [\[Next Page\]](#)

**(19) ASSY REAR CABI UPPER (DYN-2100)**

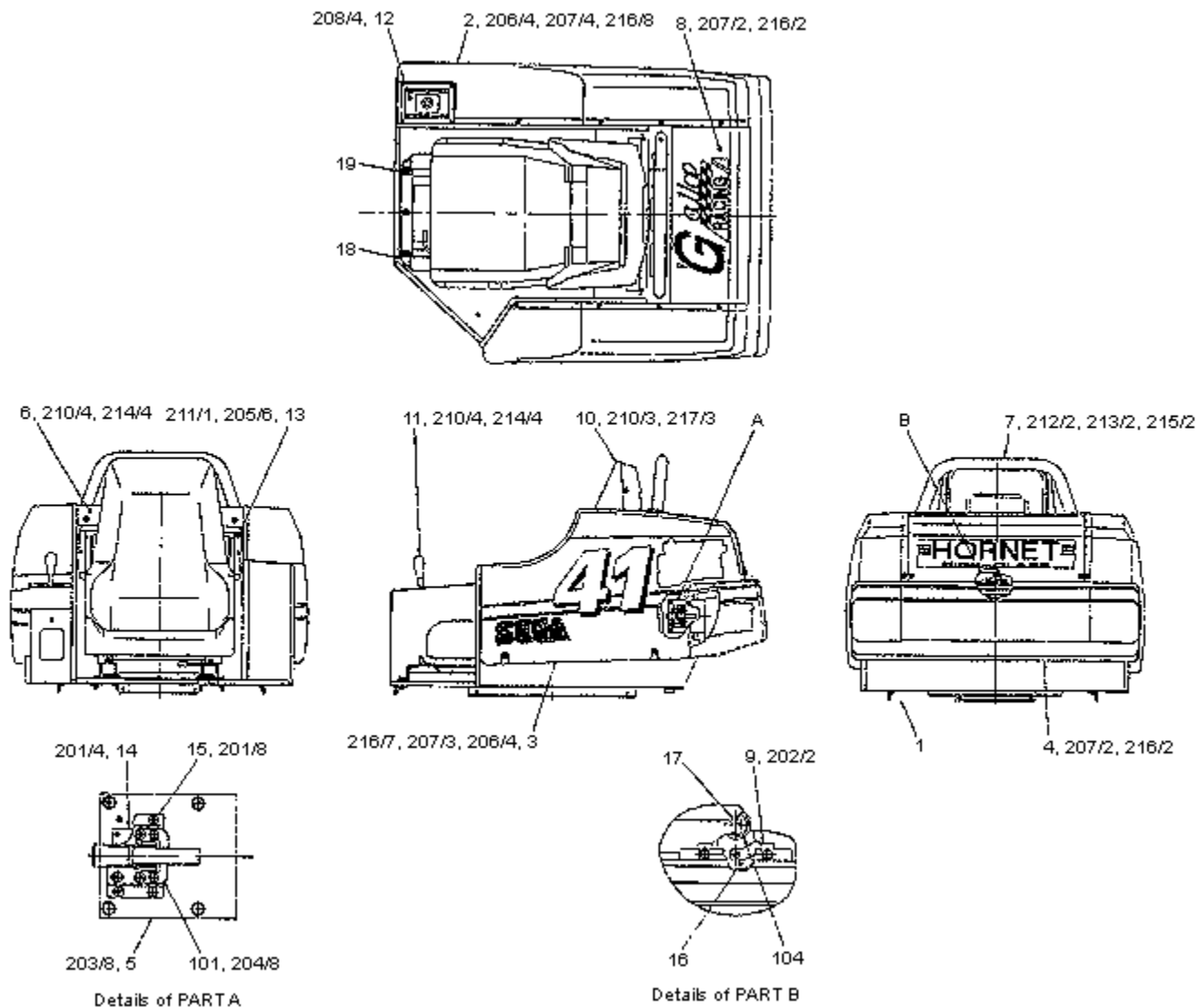

[\[Table of Contents\]](#) [\[Parts Index\]](#) [\[Previous Page\]](#) [\[Next Page\]](#)

**(20) ASSY SUB CABI REAR U (DYN-2101)**

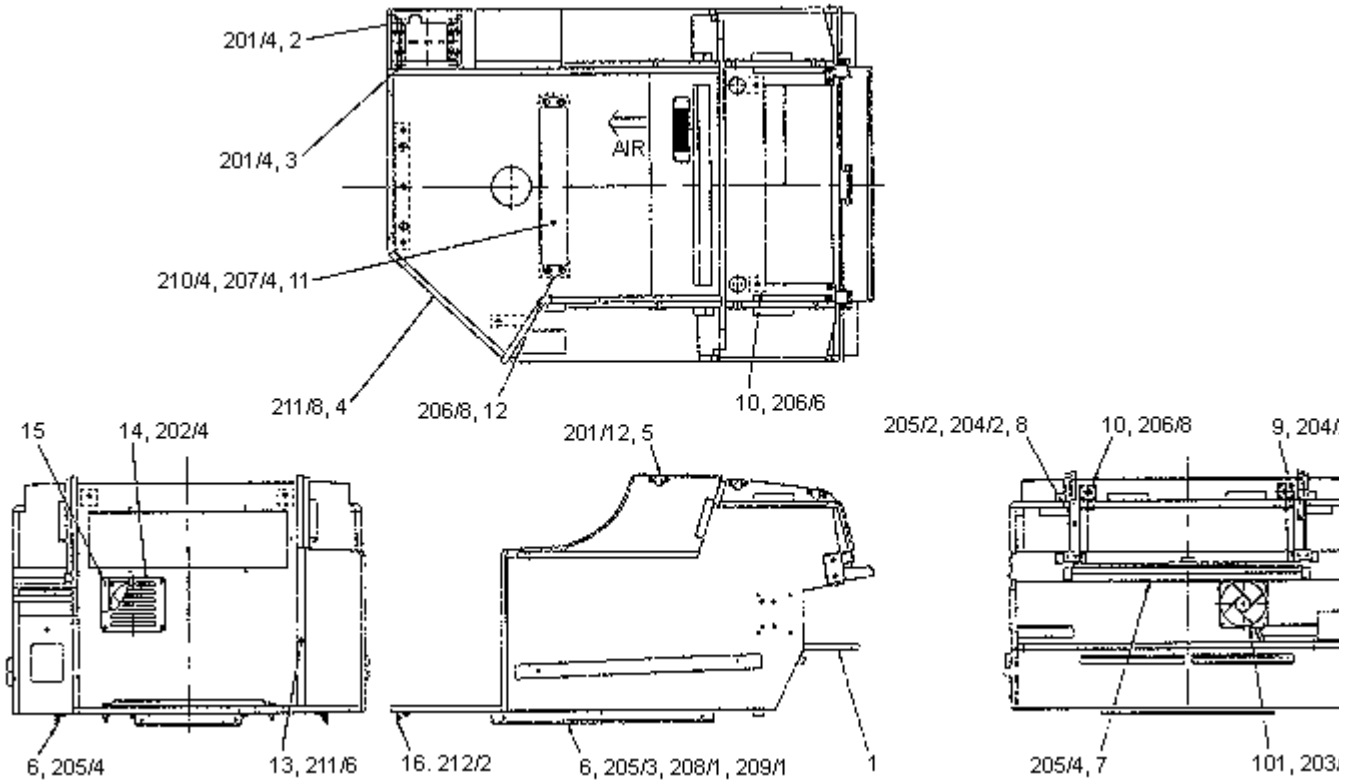



[\[Table of Contents\]](#) [\[Parts Index\]](#) [\[Previous Page\]](#) [\[Next Page\]](#)

## (21) ASSY SEAT (DYN-2130)

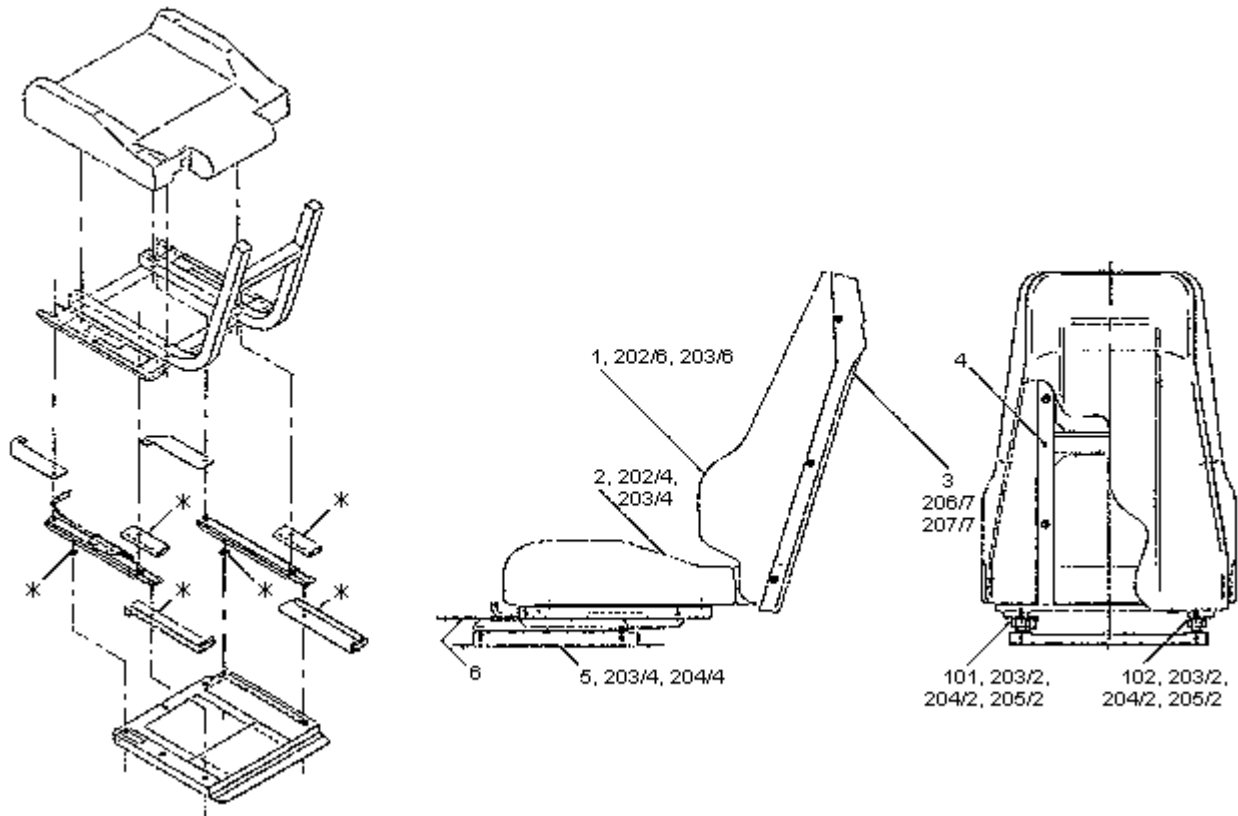

### SLIDE RAIL ASSEMBLY DETAILS

NOTE: The parts marked with (\*) shown above are the components of (101) or (102) as applicable.

ITEM NO.	PART NO.	DESCRIPTION
1	DYN-2131	UPPER SEAT
2	DYN-2132	LOWER SEAT
3	DYN-2133	SEAT BACK COVER
4	DYN-2134	SEAT FRAME
5	DYN-2135	SEAT RAIL BASE
6	DYN-2138	PROTECT RUBBER
101	601-7524	SLIDE RAIL L 180
102	601-7525	SLIDE RAIL R 180
202	030-000850-SB	HEX BLT W/S BLK M8 X 50
203	060-F00800-OB	FLT WSHR BLK M8
204	050-H00800-OB	HEX NUT BLK M8

205	060-S00800-OB	SPR WSHR BLK M8
206	000-T00412-OB	M SCR TH BLK M4 X 12
207	068-441616-OB	FLT WSHR BLK 4.4-16 X 1.6

[\[Table of Contents\]](#) [\[Parts Index\]](#) [\[Previous Page\]](#) [\[Next Page\]](#)

**(22) ASSY 4 SPEED SHIFTER (DYN-2150)**

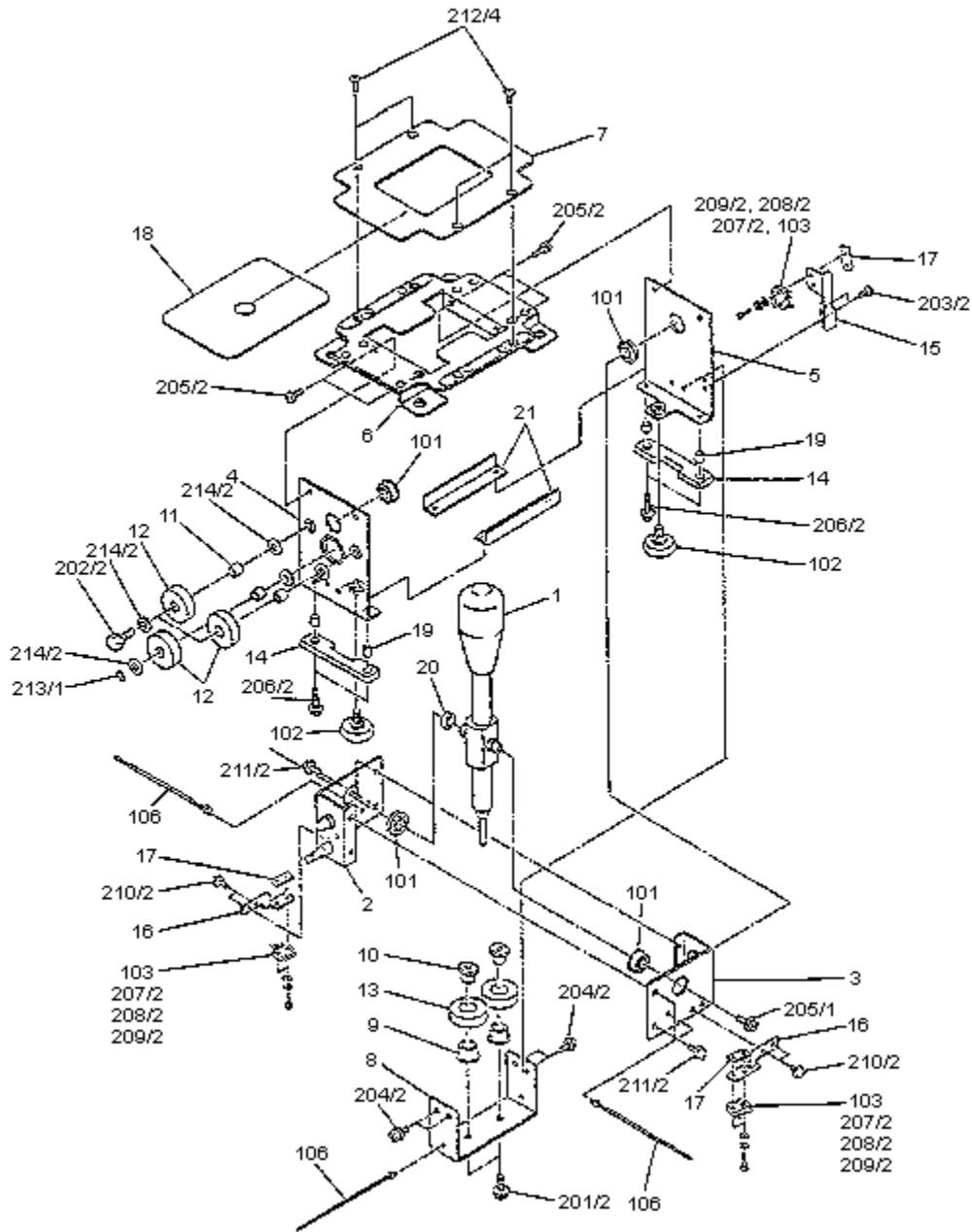

[\[Table of Contents\]](#) [\[Parts Index\]](#) [\[Previous Page\]](#) [\[Next Page\]](#)

### (23) ASSY REAR SPEAKER (DYN-2190)

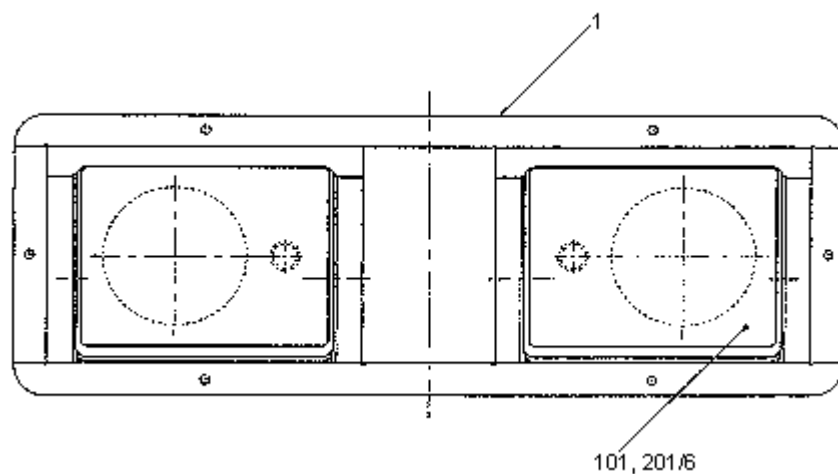

ITEM NO.	PART NO.	DESCRIPTION
1	DYN-2191	SPEAKER BRACKET REAR
101	130-5096	SPEAKER BOX SERVO
102	601-0460	PLASTIC TIE BELT 100mm
103	280-0425	CORD CLAMP Ø10
201	000-P00512-W	M SCR PH W/FS M5 X 12
301	600-6363-73	WIRE HARN REAR SPEAKER

---

[\[Table of Contents\]](#) [\[Parts Index\]](#) [\[Previous Page\]](#) [\[Next Page\]](#)

---

**(24) ASSY REAR CABI LOWER (DYN-2200)**

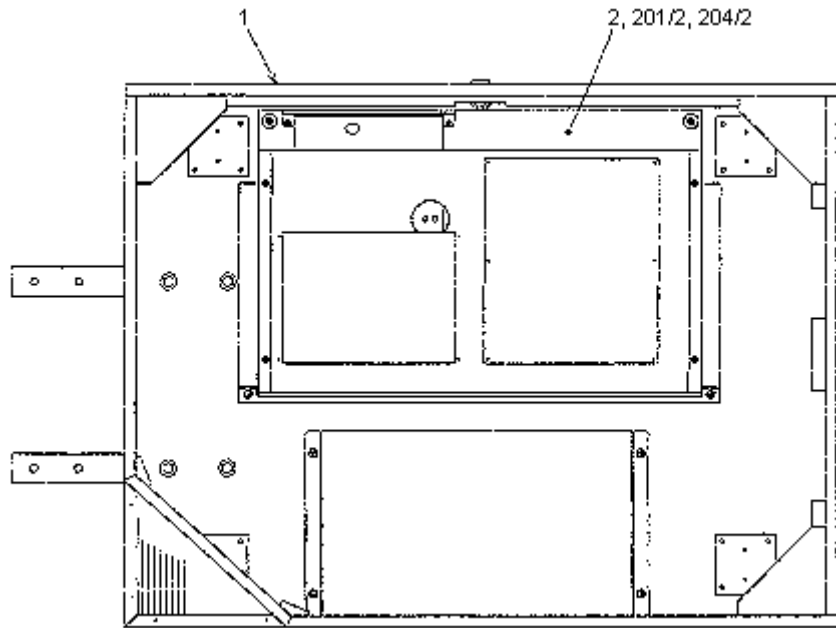

[\[Table of Contents\]](#) [\[Parts Index\]](#) [\[Previous Page\]](#) [\[Next Page\]](#)

**(25) ASSY SUB CABI REAR L (DYN-2201)**

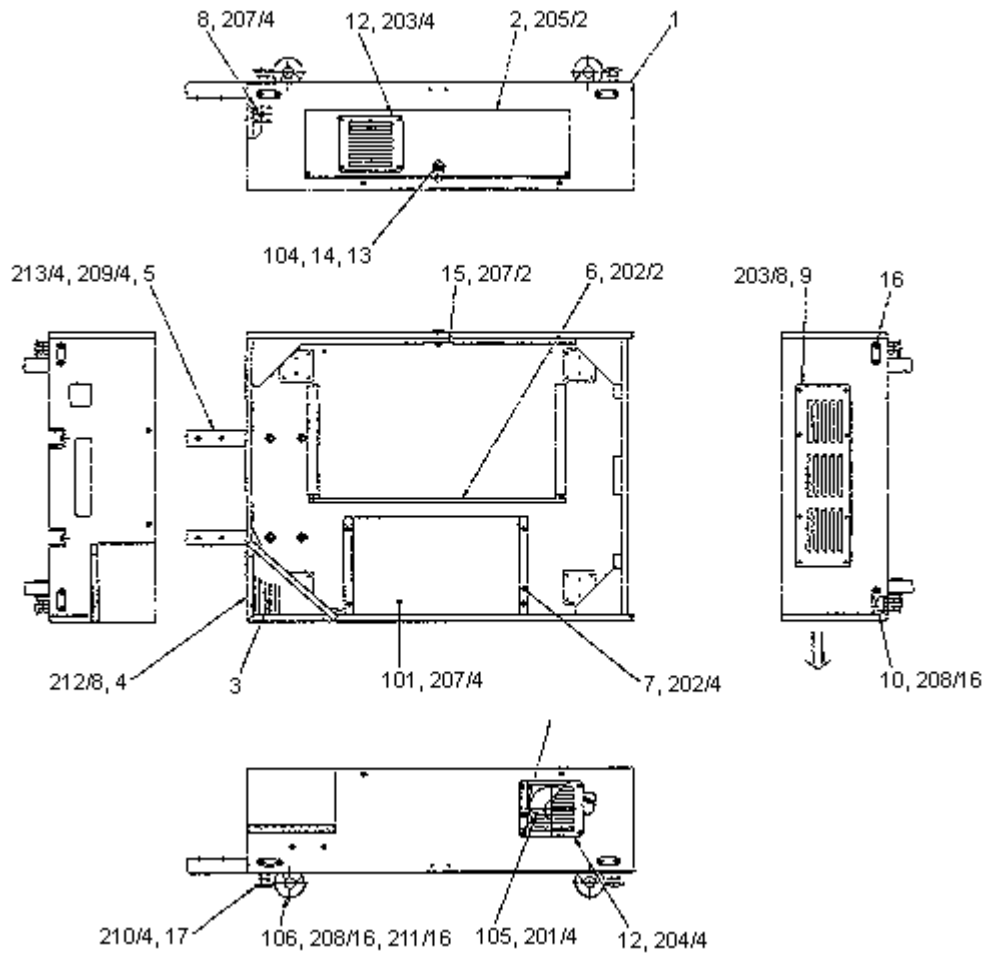

[\[Table of Contents\]](#) [\[Parts Index\]](#) [\[Previous Page\]](#) [\[Next Page\]](#)

**(26) ASSY SHIELD CASE (DYN-2300)**

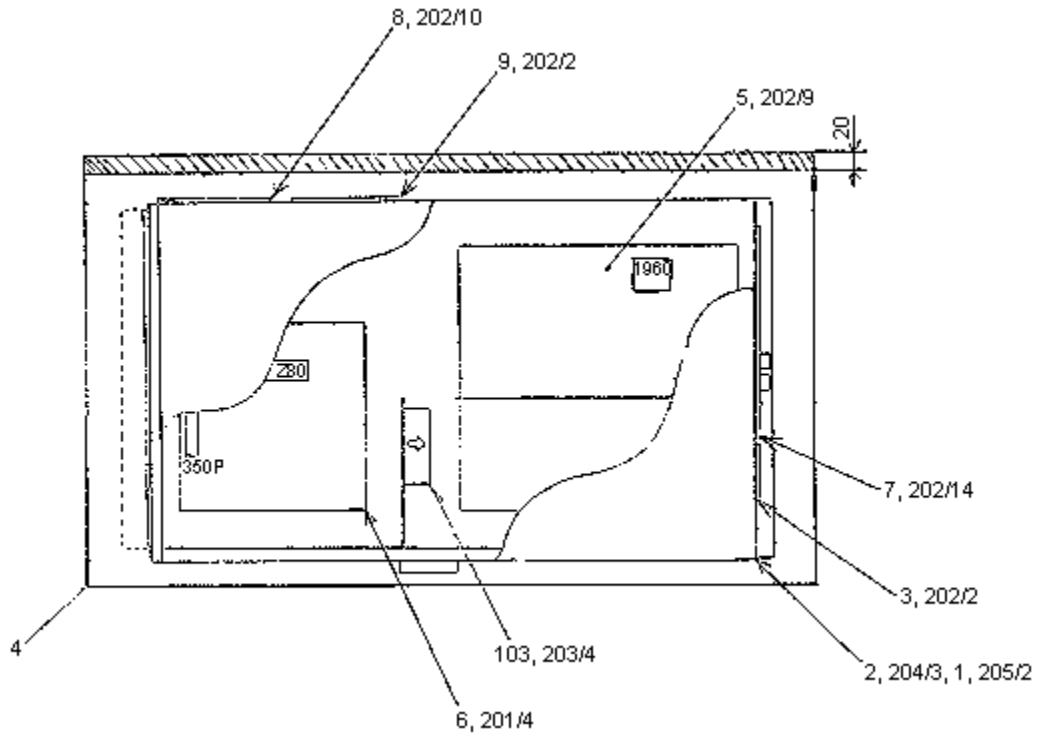

[\[Table of Contents\]](#) [\[Parts Index\]](#) [\[Previous Page\]](#) [\[Next Page\]](#)

**(27) ASSY PWR SPLY (DYN-4000)**

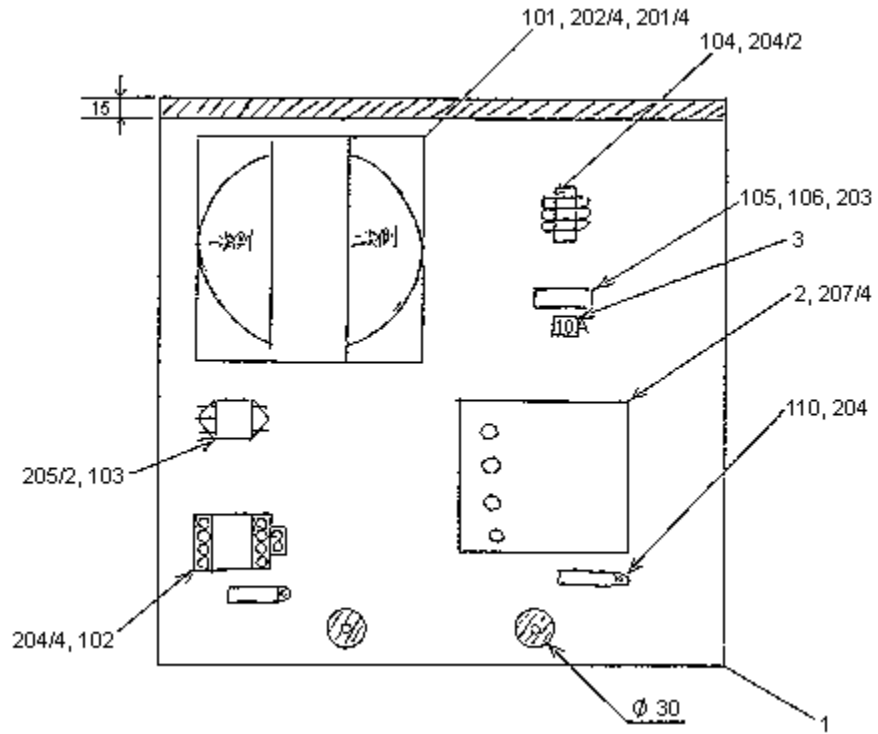



[\[Table of Contents\]](#) [\[Parts Index\]](#) [\[Previous Page\]](#) [\[Next Page\]](#)

**(28) ASSY ELEC (DYN-4100)**

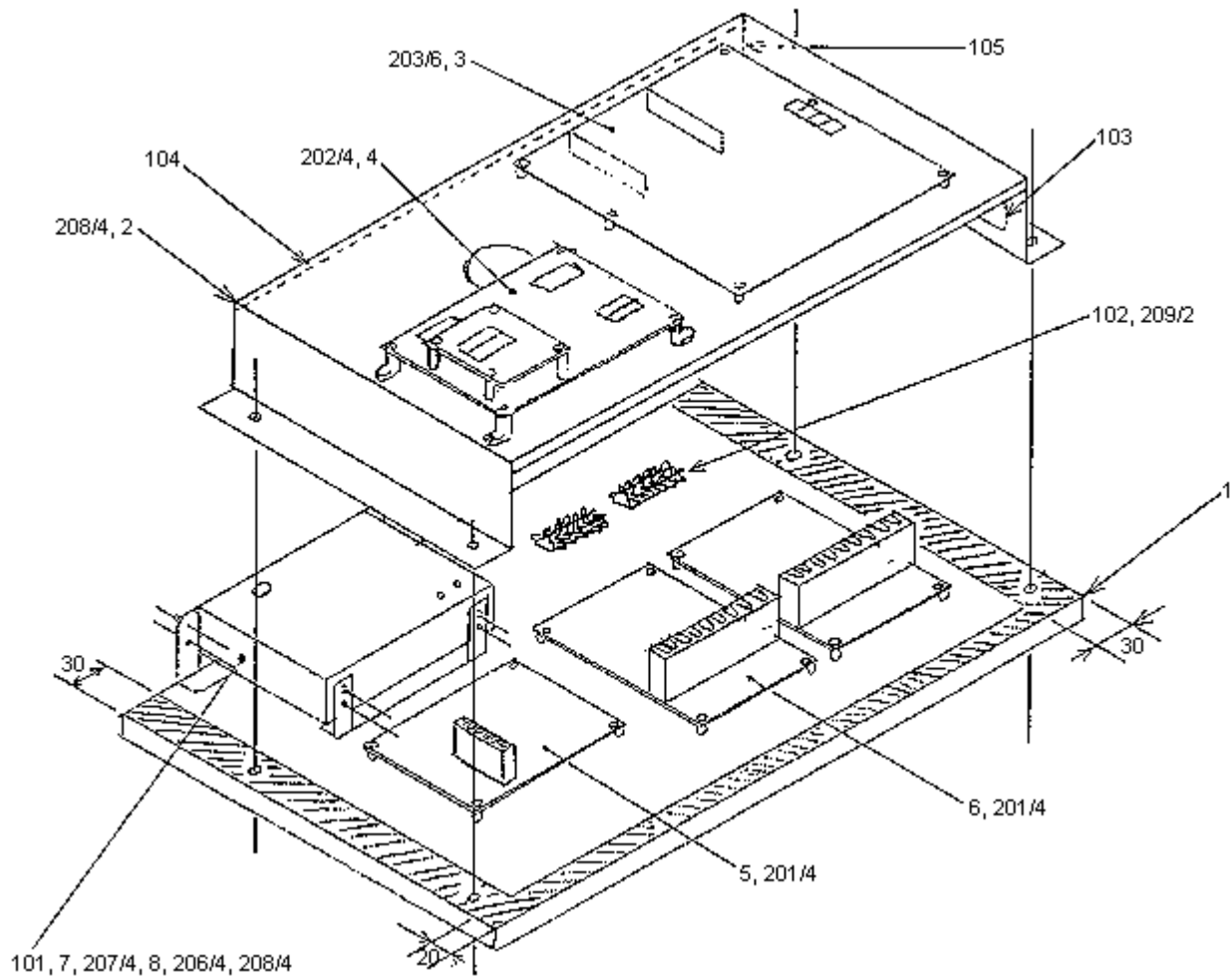

[\[Table of Contents\]](#) [\[Parts Index\]](#) [\[Previous Page\]](#) [\[Next Page\]](#)

## 20. WIRE COLOR CODE TABLE

THE WIRE COLOR CODE is as follows:

A	PINK
B	SKY BLUE
C	BROWN
D	PURPLE
E	LIGHT GREEN

Wires other than those of any of the above 5 single colors will be displayed by 2 alphanumeric characters.

1	RED
2	BLUE
3	YELLOW
4	GREEN
5	WHITE
7	ORANGE
8	BLACK
9	GRAY

If the right-hand side numeral of the code is 0, then the wire will be of a single color shown by the left-hand side numeral (see the above).

Note 1 : If the right-hand side alphanumeric is not 0, that particular wire has a spiral color code. The left-hand side character shows the base color and the right-hand side one, the spiral color.

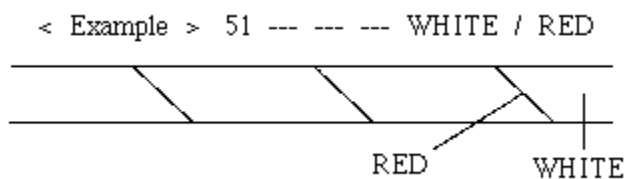

Note 2 : The character following the wire color code indicates the size of the wire.

K :	A W G 18,	U L 1015
L:	A W G 20,	U L 1007
None:	A W G 22,	U L 1007

## Free Manuals Download Website

<http://myh66.com>

<http://usermanuals.us>

<http://www.somanuals.com>

<http://www.4manuals.cc>

<http://www.manual-lib.com>

<http://www.404manual.com>

<http://www.luxmanual.com>

<http://aubethermostatmanual.com>

Golf course search by state

<http://golfingnear.com>

Email search by domain

<http://emailbydomain.com>

Auto manuals search

<http://auto.somanuals.com>

TV manuals search

<http://tv.somanuals.com>