

GEBRAUCHSANLEITUNG  
INSTRUCTIONS FOR USE  
NOTICE D'EMPLOI  
ISTRUZIONI PER L'USO  
INSTRUCCIONES PARA EL USO  
GEBRUIKSAANWIJZING

# MKH 800

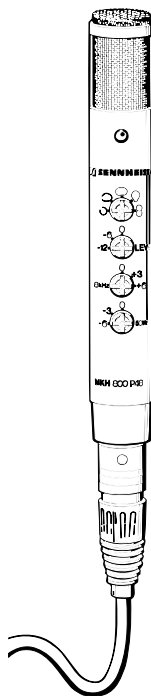



## Gebrauchsanleitung

Kurzbeschreibung	6
Anschluß und Speisemöglichkeiten	6
Befestigung auf dem Stativ / Einspracherichtung	7
Anwendungshinweise	7
Wahl der Richtcharakteristik	8
Vordämpfung einstellen / Klangkorrektur	10
Zubehör	11
Technische Daten	12
Soll-Frequenzgänge mit Toleranzfeldern / Polardiagramme	53-57
Wirkung der schaltbaren Filter: Höhenanhebung / Baßabsenkung	58

## Instructions for use

Brief description	14
Connecting facilities / power supply	14
Stand mounting / acceptance angles	15
Application tips	15
Selection of pick-up patterns	16
Preattenuation / tone control	18
Accessories	19
Technical Data	20
Nominal frequency response with tolerance field / pick-up pattern	53-57
Switchable filters: treble emphasis / bass attenuation	58

## Instructions pour l'usage

Description	22
Raccordement et alimentation	22
Fixation sur pied de microphone / direction d'où on parle au microphone	23
Instructions pour l'emploi	23
Sélection de la directivité	24
Réglage de la préatténuation / correction du son	26
Accessoires	27
Caractéristiques techniques	28
Réponse en fréquence / diagrammes de la directivité	53-57
Effet des filtres commutables: accentuation des aigües / atténuation des graves	58

## Istruzioni per l'uso

Breve descrizione . . . . .	30
Collegamento e possibilità di alimentazione . . . . .	30
Fissaggio al cavalletto / direzione entrata microfono . . . . .	31
Avvertenze per l'impiego . . . . .	31
Selezione della caratteristica di direttività . . . . .	32
Regolazione della preattenuazione / correzione del suono . . . . .	34
Accessori . . . . .	35
Dati tecnici . . . . .	36
Risposte armoniche nominali con campi di tolleranza / diagrammi polari . . . . .	53-57
Effetto dei filtri commutabili: accentuazione degli alti / taglio dei bassi . . . . .	58

## Modo de empleo

Descripción . . . . .	38
Conexión y alimentación . . . . .	38
Fijación sobre soporte de micrófono / dirección de la se habla en el micrófono . . . . .	39
Instrucciones de empleo . . . . .	39
Selección de la directividad . . . . .	40
Ajuste de la preatenuación / corrección del sonido . . . . .	42
Accesorios . . . . .	43
Características técnicas . . . . .	44
Respuesta en frecuencia / diagramas de la directividad . . . . .	53-57
Efecto de los filtros conmut.: acentuación de alturas / atenuación de bajos . . . . .	58

## Gebruiksaanwijzing

Korte beschrijving . . . . .	46
Aansluiting en voedingsmogelijkheden . . . . .	46
Bevestiging op het statief / inspreekrichting . . . . .	47
Gebruiksaanwijzing . . . . .	47
Keuze van de richtkarakteristiek . . . . .	48
Het instellen van de voordemping / klankcorrectie . . . . .	50
Accessoires . . . . .	51
Technische gegevens . . . . .	52
Ingestelde frequentiekarakteristiek met tolerantie-velden / pooldiagrammen . . . . .	53-57
Werking van de regelbare filters: hoogte-ophaling / basverlaging . . . . .	58

## INSTRUCTIONS FOR USE

# MKH 800

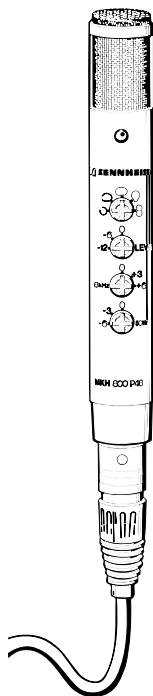

## Brief description

The MKH 800 is a versatile studio condenser microphone with five different pick-up patterns. It incorporates a push-pull transducer featuring a high linearity.

- Extremely low inherent noise - no masking effects; the recording gets an extraordinary sense of space and depth
- Excellent sensitivity for interference-free sound reproduction and high signal strength. The inherent noise of following microphone amplifiers is negligible.
- The frequency range, which is extended to up to 50 kHz, improves the resolution for complex acoustic details.
- Stable directivity prevents coloration both in the near field and in the diffuse field.
- No negative acoustic effects caused by the housing or the sound inlet basket.
- The mic's slender design and small dimensions make it visually unobtrusive.

## Connecting facilities/power supply

The MKH 800 is designed for 48 V phantom powering as per DIN 45596. For power supply units and connecting cables please see "Accessories".

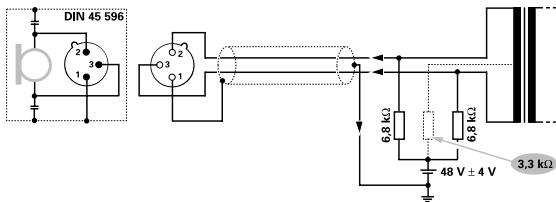

### Note well:

The extension cable is to be put between the power supply unit and the mixing console. The total length of the cable shall not exceed 200 m. For longer cables the line capacitance affects the frequency response of the microphone. Trebles are undesirably attenuated.

## Stand mounting/acceptance angles

The MZS 80 clamp with shock mount (included) serves to fix the MKH 800 to a stand.

The proper acceptance angle is indicated by the red LED.

The MZS 80 shock mount provides better resistance to footfall.

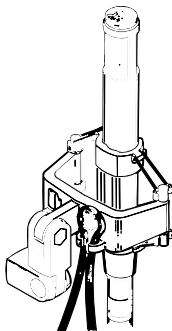

## Application tips

The MKH 800 is a versatile condenser microphone which is particularly well suited to applications in the studio recording environment.

- Its problem-free reproduction of high sound pressure levels makes it the perfect mic for soloist. It also works exceptionally well as a supporting mic.
- Its low inherent noise makes the MKH 800 the ideal principal microphone.
- If the microphone is set to the supercardioid pick-up pattern, the monitors in the studio need not be switched off in order to prevent feedback.
- The MZW 80-1 pop shield effectively suppresses pop noise during close miking. A special gauze pop shield is in preparation.
- The extended frequency response is in particular suitable for recordings with a sampling rate of 96 kHz.

## Selection of pick-up patterns

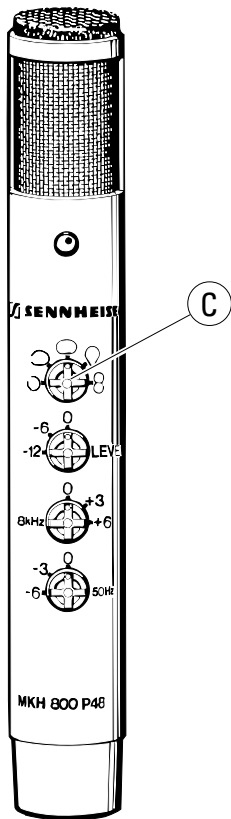

Switch **C** serves to set the mic to five different pick-up patterns:



### Omnidirectional

The push-pull transducer incorporated into the MKH 800 reduces the mic's directivity to a minimum for high frequencies. The mic has a neutral response to direct and diffuse signals. This feature provides a sense of space and depth and allows large sound sources to be miked. For close-miking, sound reproduction does not become overbrilliant or shrill. No proximity effect.



### Wide-angle cardioid

The wide-angle cardioid pick-up pattern is a combination of the omnidirectional and the cardioid pick-up pattern. A rear attenuation of 10 dB allows a moderate attenuation of diffuse signals from the rear and thus a good reverberation balance for longer distances to the sound source, even in rooms which are acoustically less perfect. Like the omnidirectional pick-up pattern, the wide-angle cardioid pick-up pattern is particularly well suited to mike large sound sources. For close-miking, the mic's bass emphasis is less high than with the cardioid pick-up pattern.





## Cardioid

The cardioid pick-up pattern is acoustically neutral for large acceptance angles. Typical for the push-pull transducer is its high rear attenuation for low frequencies (typ. 30 dB), which allows signals from the rear to be effectively attenuated. The cardioid pick-up pattern is the most versatile characteristic. It is the ideal choice for speakers, soloists and smaller instrument groups.



## Supercardioid

The supercardioid pick-up pattern features a higher directivity than the cardioid pick-up pattern, which results in efficient attenuation of diffuse signals and prevents feedback. Thanks to its good lateral attenuation (10 dB), the supercardioid pick-up pattern is particularly well suited to mike or support soloists in noisy environments, i.e. situations in which lateral sound is to be effectively suppressed. In this case, too, the transducer provides a frequency-independent directivity.



## Figure-of-eight

The figure-of-eight pick-up pattern provides total attenuation of lateral sound, which makes it particularly well suited to separate or support adjacent sound sources such as single instruments or instrument groups in large orchestras. Annoying reflections from the floor and the resulting comb filter effects can be effectively reduced.

## Preattenuation / tone control

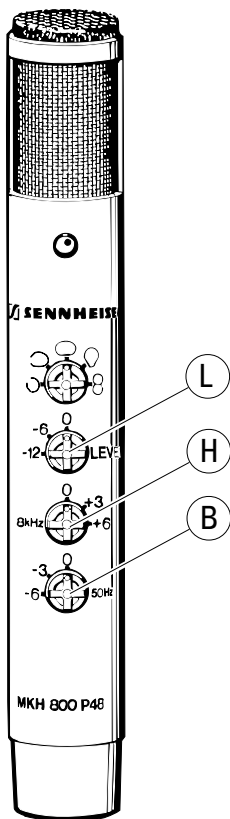

Switch L for preattenuation

If the output level of the MKH 800 is too high for the following mixing console, it can be reduced in two steps:

**- 6 dB**

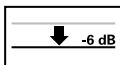

or

**- 12 dB**

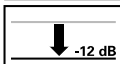

Switch H for treble emphasis

The treble emphasis can be adjusted in two steps. For 8 kHz the increase amounts to:

**+ 3 dB**

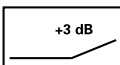

or

**+ 6 dB**

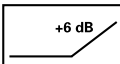

Switch B for bass attenuation

The bass response can be attenuated in two steps. For 50 Hz the attenuation amounts to:

**- 3 dB**



or

**- 6 dB**



## Accessories

### MZW 80-1

#### Foam wind-shield

functions as a close-miking and pop shield.

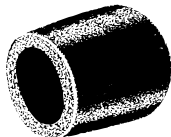

### KA 7 U

#### XLR connecting cable

Three-core cable with XLR/XLR connector. Length: 7.5 m. Usable as a connecting cable or an extension cable. Preattenuation/tone control

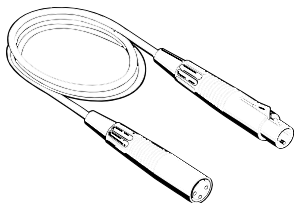

## Technical Data

short description	high-frequency studio condenser microphone with 5 switchable directional characteristics
transducer type	double push-pull pressure-gradient transducer
directional characteristics	omnidirectional, wide-angle cardioid, cardioid, super cardioid, figure-8
frequency range	30 - 50000 Hz
sensitivity	40 mV/Pa $\pm$ 1dB (-28 dB re 1 V/Pa)
output impedance	150 $\Omega$
maximum SPL	136 dB SPL (142 dB SPL with 6/12 dB preattenuation)
maximum output voltage	5 V
equivalent SPL due to inherent noise	20 dB SPL (CCIR-weighted) 10 dB SPL (A-weighted)
output voltage due to inherent noise	8 $\mu$ V (CCIR-weighted) 2.5 $\mu$ V (A-weighted)
S/N ratio at 94 dB SPL ( 1 Pa)	74 dB (CCIR-weighted) 84 dB (A-weighted)
dynamic range	116 dB (CCIR-weighted) 126 dB (A-weighted)
switchable pre-attenuation	6/12 dB (20/10 mV/Pa)
switchable bass roll-off	3/6 dB at 50 Hz
switchable treble emphasis	3/6 dB at 8 kHz
feeding	phantom feeding P48
supply voltage / supply current	48 $\pm$ 4 V / 3 mA
connector	XLR-3
diameter	26.5 mm
length	178 mm
weight	135 g

Subject to alterations.

Soll-Frequenzgang mit Toleranzfeld / Polardiagramm  
 Nominal frequency response with tolerance field / Pick-up pattern  
 Réponse en fréquence / Diagramme de la directivité  
 Risposta in frequenza / Diagramma polare  
 Respuesta en frecuencia / Diagrama de la directividad  
 Ingestelde frequentiekarakteristiek met tolerantie-velden / Pooldiagrammen

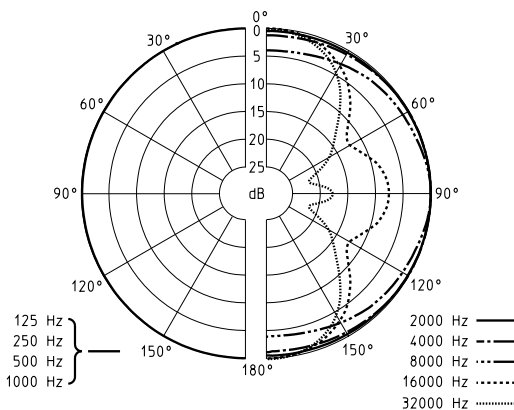
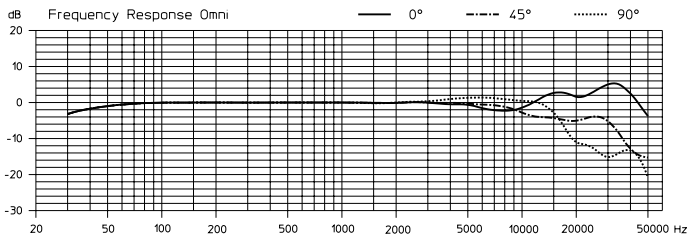
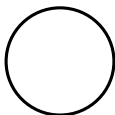

Soll-Frequenzgang mit Toleranzfeld / Polardiagramm  
 Nominal frequency response with tolerance field / Pick-up pattern  
 Réponse en fréquence / Diagramme de la directivité  
 Risposta in frequenza / Diagramma polare  
 Respuesta en frecuencia / Diagrama de la directividad  
 Ingestelde frequentiekarakteristiek met tolerantie-velden / Pooldiagrammen

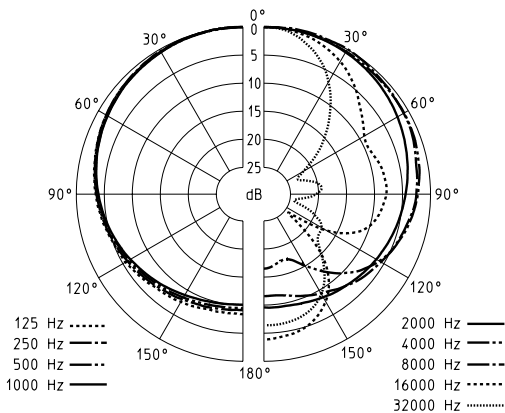
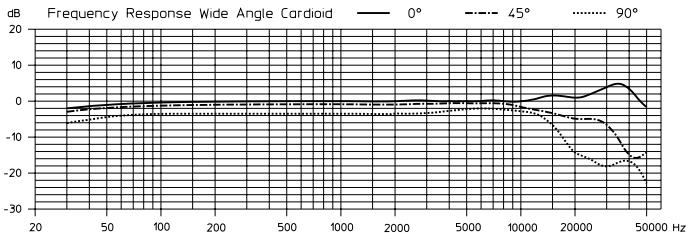
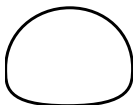

Soll-Frequenzgang mit Toleranzfeld / Polardiagramm  
 Nominal frequency response with tolerance field / Pick-up pattern  
 Réponse en fréquence / Diagramme de la directivité  
 Risposta in frequenza / Diagramma polare  
 Respuesta en frecuencia / Diagrama de la directividad  
 Ingestelde frequentiekarakteristiek met tolerantie-velden / Pooldiagrammen

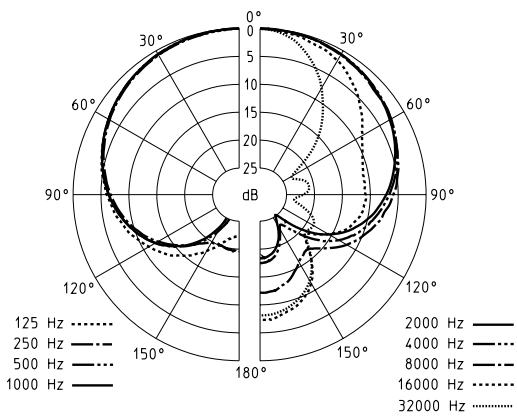
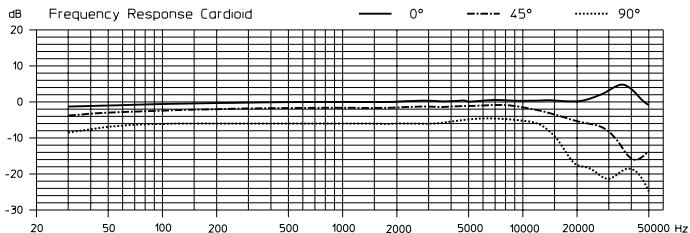
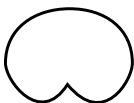





Soll-Frequenzgang mit Toleranzfeld / Polardiagramm  
 Nominal frequency response with tolerance field / Pick-up pattern  
 Réponse en fréquence / Diagramme de la directivité  
 Risposta in frequenza / Diagramma polare  
 Respuesta en frecuencia / Diagrama de la directividad  
 Ingestelde frequentiearakteristiek met tolerantie-velden / Pooldiagrammen

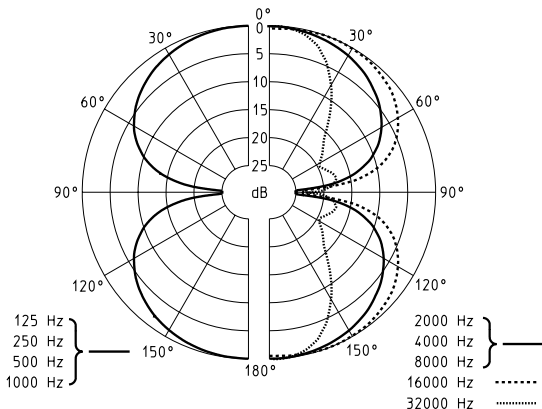
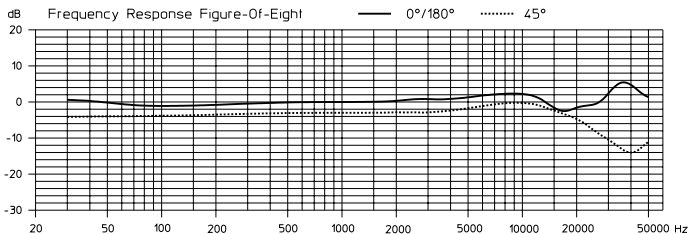

Wirkung der schaltbaren Filter  
 Filter effects  
 Effet des filtres commutables  
 Effetto dei filtri commutabili  
 Efecto de los filtros conmutables  
 Werking van de regelbare filters

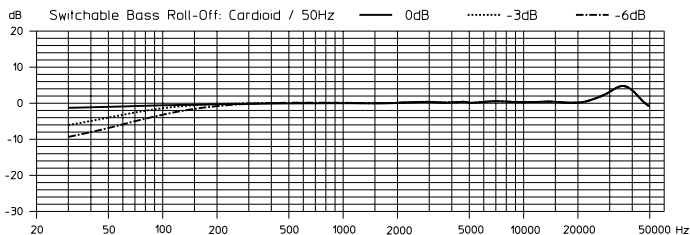
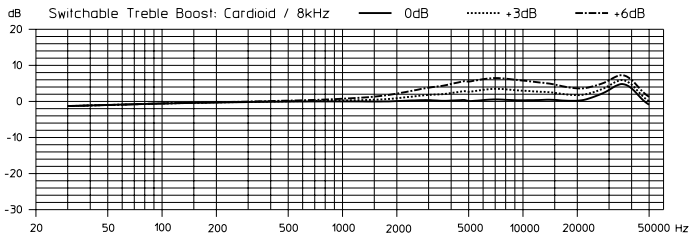
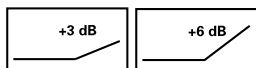

0dB corresponds to -28 dBV/Pa

Aktuelle Informationen zu Sennheiser-Produkten erhalten  
Sie auch im Internet unter „<http://www.sennheiser.com>“.

Up to date information on Sennheiser products can also be found  
on the Internet under “<http://www.sennheiser.com>”.

Vous trouverez également toutes les informations actuelles relatives aux  
produits Sennheiser sur Internet, sous “<http://www.sennheiser.com>“.

Informazioni attuali sulla gamma di prodotti Sennheiser sono  
disponibili anche in Internet al sito „<http://www.sennheiser.com>“.

También en Internet, bajo „<http://www.sennheiser.com>“ obtendrá Vd.  
informaciones actuales sobre los productos Sennheiser.

Actuele informatie met betrekking tot Sennheiser producten  
vindt u ook op Internet onder “<http://www.sennheiser.com>“.



Sennheiser electronic GmbH & Co. KG  
D 30900 Wedemark  
Printed in Germany

Publ. 80623  
12/99  
A 01

## Free Manuals Download Website

<http://myh66.com>

<http://usermanuals.us>

<http://www.somanuals.com>

<http://www.4manuals.cc>

<http://www.manual-lib.com>

<http://www.404manual.com>

<http://www.luxmanual.com>

<http://aubethermostatmanual.com>

Golf course search by state

<http://golfingnear.com>

Email search by domain

<http://emailbydomain.com>

Auto manuals search

<http://auto.somanuals.com>

TV manuals search

<http://tv.somanuals.com>