

CC543

USER'S GUIDE

Important Information	1
Table of Contents.....	1
Optional Accessories.....	2
First-Time Operation	10
Powering Your Camcorder.....	16
Camcorder Features	24
Recording Features.....	26
Recording Tips	47
Playback	50
Care and Maintenance.....	60
Specification.....	61
Limited Warranty.....	62
Index	66

CC543

1994

CC543



CAMCORDER

TRON

TIPSS 01
009276

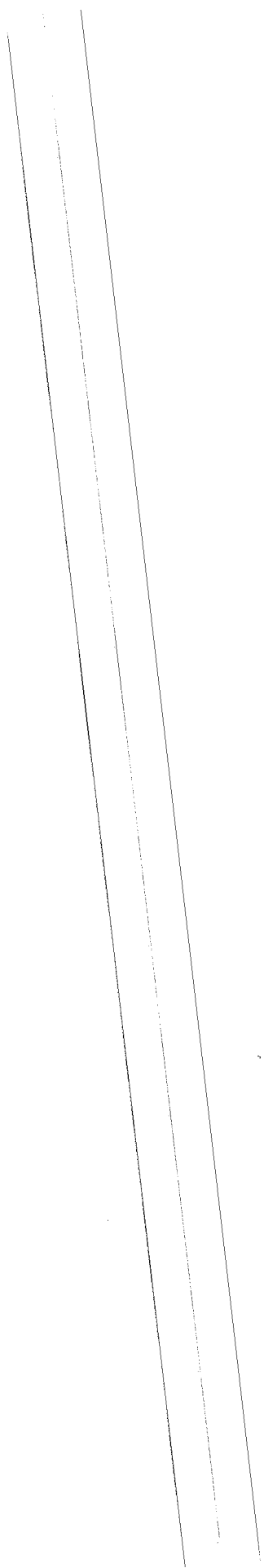

Product Registration

Please fill out the product registration card and return it immediately. Returning this card allows us to contact you if needed.

Keep your sales receipt to obtain warranty parts and service and for proof of purchase. Attach it here and record the serial and model numbers in case you ever need them. The numbers are located on the back of your camcorder.

Model No: CC543

Serial No: _____

Purchase Date: _____

Purchased From: _____

SAFETY PRECAUTIONS

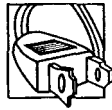

Your video camcorder's AC adapter/charger will operate on 120 volts AC, 50/60 Hz, and has a polarized plug. Because one blade of the plug is wider than the other, the plug fits in the wall socket only one way. Do not defeat the safety feature of this plug. If you need an extension cord, use a polarized extension cord.

CAUTION: TO PREVENT ELECTRIC SHOCK, MATCH WIDE BLADE OF PLUG TO WIDE SLOT, FULLY INSERT.

ATTENTION: POUR ÉVITER LES CHOCs ÉLECTRIQUES, INTRODUIRE LA LAME LA PLUS LARGE DE LA FICHE DANS LA BORNE CORRESPONDANTE DE LA PRISE ET POUSSER JUSQU'AU FOND.

CAUTION: TO REDUCE THE RISK OF ELECTRIC SHOCK, DO NOT REMOVE THE COVER (OR BACK). NO USER-SERVICEABLE PARTS ARE INSIDE. IF YOU SPILL LIQUID ON THE CAMCORDER OR ADAPTER/CHARGER, DISCONNECT THE AC ADAPTER/CHARGER'S POWER CORD TO PREVENT POSSIBLE FIRE OR SHOCK HAZARD AND CONSULT AUTHORIZED SERVICE PERSONNEL. MOISTURE CAN DAMAGE INTERNAL PARTS. REFER ALL SERVICE TO AUTHORIZED RCA CAMCORDER SERVICENTER PERSONNEL ONLY.

SAFETY PRECAUTIONS (continued)

CAUTION: READ "IMPORTANT SAFETY INSTRUCTIONS FOR AC ADAPTER/CHARGER" ON THE NEXT PAGE BEFORE USING THE AC ADAPTER/CHARGER.

CAUTION: MAINTAIN ELECTRICAL SAFETY. POWERLINE-OPERATED EQUIPMENT OR ACCESSORIES CONNECTED TO THIS UNIT SHOULD BEAR THE UL LISTING MARK OR, IF PURCHASED AND USED IN CANADA, THE CSA CERTIFICATION MARK OR THE C-UL MARK ON THE ACCESSORIES THEMSELVES AND SHOULD NOT HAVE BEEN MODIFIED SO AS TO DEFEAT THE SAFETY FEATURES. THIS WILL HELP AVOID ANY POTENTIAL HAZARD FROM ELECTRIC SHOCK OR FIRE. IF IN DOUBT, CONTACT QUALIFIED SERVICE PERSONNEL.

WARNING: TO REDUCE THE RISK OF FIRE OR SHOCK HAZARD, DO NOT EXPOSE CAMCORDER OR AC ADAPTER/CHARGER TO RAIN OR MOISTURE.

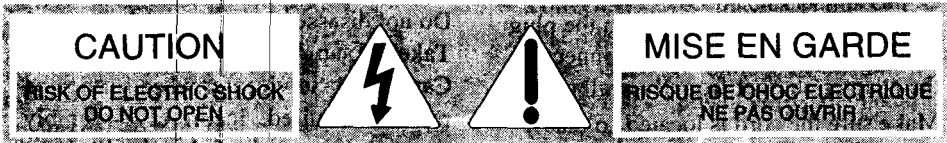

The symbol of a lightning flash within a triangle is intended to alert the user to the presence of uninsulated "dangerous voltage" within the product's enclosure and which may be of sufficient magnitude to constitute a risk of electric shock.



An exclamation point within a triangle is intended to alert the user to the presence of important operating and maintenance (service) instructions in the literature accompanying the product.

CAUTION: AVOID OPERATING YOUR CAMCORDER IMMEDIATELY AFTER MOVING IT FROM A COLD LOCATION TO A WARM LOCATION. GIVE THE CAMCORDER 2 TO 3 HOURS TO REACH A STABLE TEMPERATURE BEFORE INSERTING A VIDEO CASSETTE. WHEN MOVED FROM A COLD AREA TO A WARM LOCATION, MOISTURE MAY CONDENSE ON THE HEAD DRUM INSIDE THE MACHINE. THIS MOISTURE COULD CAUSE THE TAPE TO STICK TO THE HEADWHEEL AND DAMAGE THE HEADWHEEL OR TAPE.

IMPORTANT SAFETY INSTRUCTIONS

Important Safety Instructions for AC Adapter/Charger

Before using the AC adapter/charger, read all instructions and cautionary markings on (1) AC adapter/charger, (2) battery, and (3) product using battery.

Caution: To reduce risk of injury, charge only rechargeable batteries type **EP096FS, EP096FL, CB096FS, or CB096FL**. Other types of batteries may burst causing personal injury and damage.

Do not expose the adapter/charger to moisture of any kind.

Use of an attachment not recommended or sold by the battery charger manufacturer may result in a risk of fire, electric shock, or injury to persons.

To reduce risk of damage to electric plug and cord, pull out the cord with the plug rather than the cord when disconnecting the adapter/charger from the wall outlet.

Make sure the cord is located so that it will not be stepped on, tripped over, or otherwise subjected to damage or stress.

Use of an improper extension cord could result in a risk of fire and electric shock.

If an extension cord must be used, make sure that:

1. Pins on the plug of the extension cord are the same number, size, and shape as those of the plug on the adapter/charger.

2. Extension cord is properly wired and in good electrical condition, and

3. Wire size below is met:

Minimum AWG Size	Length of Extension Cord (Feet)
18	Equal to or less than 100
16	Equal to or less than 150

Do not operate adapter/charger with a damaged cord or plug. Replace it immediately.

Do not operate adapter/charger if it has received a sharp blow, been dropped, or otherwise damaged in any way. Take it to a qualified serviceman.

Do not disassemble adapter/charger. Take it to an Authorized RCA Camcorder **Servicenter** when service or repair is required. Incorrect reassembly may result in a risk of electric shock.

To reduce risk of electric shock, unplug adapter/charger from outlet before attempting any maintenance or cleaning.

Be sure to save these operating instructions for future reference.

CAUTION: FCC REGULATIONS STATE THAT ANY UNAUTHORIZED CHANGES OR MODIFICATIONS TO THIS EQUIPMENT MAY VOID THE USER'S AUTHORITY TO OPERATE IT.

CAUTION: THE UNAUTHORIZED RECORDING OF TELEVISION PROGRAMS AND OTHER MATERIALS MAY INFRINGE THE RIGHTS OF OTHERS.

IMPORTANT SAFEGUARDS

In addition to the careful attention devoted to quality standards in the manufacture of your product, safety is a major factor in the design of every instrument. However, safety is your responsibility too.

These pages list important information that will help to assure your enjoyment and proper use of a camcorder, adapter/charger, and accessory equipment. Please read them carefully before operating your products.

Installation

1. Read and Follow Instructions—

All the safety and operating instructions should be read before the product is operated. Follow all operating instructions.

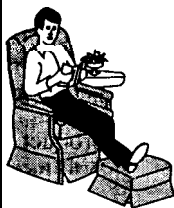

2. Retain Instructions—The safety and operating instructions should be retained for future reference.

3. Heed Warnings—Comply with all warnings on the product and in the operating instructions.

4. Polarization—This product is equipped with a polarized alternating-current line plug (a plug having one blade wider than the other). This plug will fit into the power outlet only one way. This is a safety feature. If you are unable to insert the plug fully into the outlet, try reversing the plug. If the plug still fails to fit, contact your electrician to replace your obsolete outlet. To prevent electric shock, do

not use this polarized plug with an extension cord, receptacle, or other outlet unless the blades can be fully inserted without blade exposure. If you need an extension cord, use one with a polarized plug.

5. Power Sources—This product should be operated only from the type of power source indicated on the marking label. If you are not sure of the type of power supply to your home, consult your dealer or local power company. For products intended to operate from battery power, or other sources, refer to the operating instructions.

6. Overloading—Do not overload wall outlets, extension cords, or integral convenience receptacles as this can result in a risk of fire or electric shock. Overloaded AC outlets, extension cords, frayed power cords, damaged or cracked wire insulation, and broken plugs are dangerous. They may result in a shock or fire hazard.

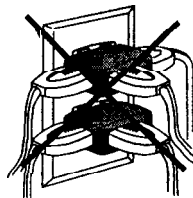

Periodically examine the cord, and if its appearance indicates damage or deteriorated insulation, have it replaced by your service technician.

7. Power-Cord Protection—Power-supply cords should be routed so that they are not likely to be walked on or pinched by items placed upon or against them, paying particular attention to cords at plugs, convenience receptacles, and the point where they exit from the product.

(continued on next page)

IMPORTANT SAFEGUARDS (continued)

8. Ventilation--Slots and openings in the products are provided for ventilation to ensure reliable operation of the product and to protect them from overheating. These openings must not be blocked or covered. The openings should never be blocked by placing the product on a bed, sofa, rug, or other similar surface. This product should not be placed in a built-in installation such as a bookcase or rack unless proper ventilation is provided or the product manufacturer's instructions have been followed.

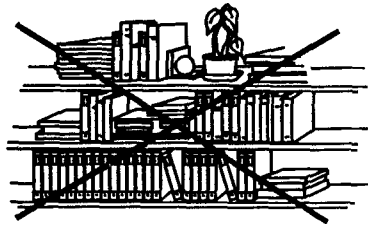

9. Attachments-Do not use attachments unless recommended by the product manufacturer as they may cause hazards.

Caution: Maintain electrical safety. Powerline operated equipment or accessories connected to this unit should bear the UL listing mark or CSA certification mark on the accessory itself and should not be modified so as to defeat the safety features. This will help avoid any potential hazard from electrical shock or fire. If in doubt, contact qualified service personnel.

10. Water and Moisture-Do not use this product near water—for example, near a bath tub, wash bowl, kitchen sink or laundry tub, in a wet basement, or near a swimming pool and the like.

11. Accessories-Do not place this product on an unstable cart, stand, tripod, bracket, or table. The product may fall, causing serious injury to a child or adult as well as serious damage to the product. Use this product only with a cart, stand, tripod, bracket, or table recommended by the manufacturer or sold with the product. Any mounting of the product should follow the manufacturer's instructions and use a mounting accessory recommended by the manufacturer.

11A A product and cart combination should be moved with care. Quick stops, excessive force, and uneven surfaces may cause the product and cart combination to overturn.



S3125A

(continued on next page)

IMPORTANT SAFEGUARDS (continued)

12. Outdoor Antenna Grounding—If an outside antenna or cable system is connected to the product, be sure the antenna or cable system is grounded so as to provide some protection against voltage surges and built-up static charges. Article 810 of the National Electrical Code, ANSI/NFPA No. 70 (Section 54 of Canadian Electrical Code, Part 1) provides information with respect to proper grounding of the mast and supporting structure, grounding of the lead-in wire to an antenna-discharge unit, size of grounding conductors, location of antenna-discharge unit, connection to grounding electrodes, and requirements for the grounding electrode. See example below as per National Electrical Code, ANSI/NFPA 70.

Example of Antenna Grounding

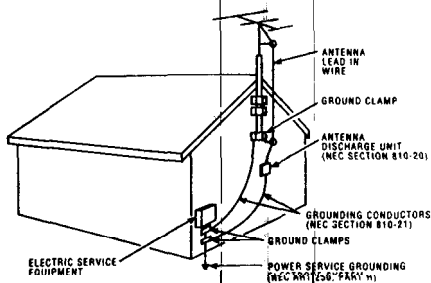

13. Power Lines—An outside antenna system should not be located in the vicinity of overhead power lines, other electric light or power circuits, or where it can fall into such power lines or circuits. When installing an outside antenna system, extreme care should be taken to keep from touching or approaching such power lines or circuits as contact with them might be fatal. Installing an outdoor antenna can be hazardous and should be left to a professional antenna installer.

Use

14. Cleaning—Unplug this product from the wall outlet before cleaning. Do not use liquid cleaners or aerosol cleaners. Use a damp cloth for cleaning.

15. Object and Liquid Entry—Never push objects of any kind into this product through openings as they may touch dangerous voltage points or “short-out” parts that could result in a fire or electric shock. Never spill liquid of any kind on the product.

(continued on next page)

IMPORTANT SAFEGUARDS (continued)

16. Lightning-For added protection for this product during a lightning storm, or when it is left unattended and unused for long periods of time, unplug it from the wall outlet and disconnect the antenna or cable system. This will prevent damage to the product due to lightning and power line surges.

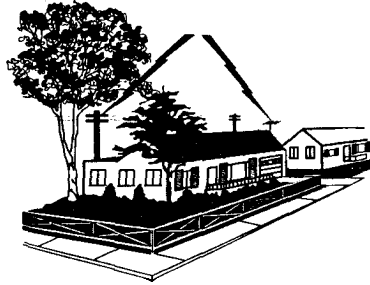

Service

17. Servicing-Do not attempt to service this product yourself as opening or removing covers may expose you to dangerous voltage or other hazards. Refer all servicing to qualified service personnel.

18. Conditions Requiring Service— Unplug this product from the wall outlet and refer servicing to qualified service personnel under the following conditions.

- A. When the power-supply cord or plug is damaged.
- B. If liquid has been spilled, or objects have fallen into the product.
- C. If the product has been exposed to rain or water.

D. If the product does not operate normally by following the operating instructions, adjust only those controls that are covered by the operating instructions.

Improper adjustment of other controls may result in damage and will often require extensive work by a qualified technician to restore the product to its normal operation.

E. If the product has been dropped in any way.

F. When the product exhibits a distinct change in **performance**—this indicates a need for service.

19. Replacement Parts-When replacement parts are required, have the service technician verify that the replacements he uses have the same safety characteristics as the original parts. Use of replacements specified by the product manufacturer can prevent fire, electric shock, or other hazards.

20. Safety Check-Upon completion of any service or repairs to this product, ask the service technician to perform safety checks recommended by the manufacturer to determine that the product is in safe operating condition.

21. Wall or Ceiling Mounting-The product should be mounted to a wall or ceiling only as recommended by the manufacturer.

22. Heat-The product should be situated away from heat sources such as radiators, heat registers, stoves, or other products (including amplifiers) that produce heat.

Table of Contents

Product Registration	32-33
Safety Precautions	i-ii
Important Safety Instructions	iii-vii
Optional Accessories	2-9
• Accessory Order Form.....	7-9
First-Time Operation	
• Unpack Camcorder and Accessories.....	10
• Attach a Power Supply.....	11
• Remove Lens Cap and Attach to Handstrap.....*	12
• Turn on the Camcorder.....	12
• Insert a Cassette.....	12
• Position Viewfinder and Adjust Eyepiece Focus Control.....	12
• Start and Stop Recording.....	13
• Play Back What You Have Recorded.....	13
• Review the Camcorder's Operating Controls.....	14-15
Powering Your Camcorder	
• Using the Adapter/Charger.....	16
• Using the Battery.....	17-20
• Using the Car Cord Adapter.....	21
Video Cassettes	22-23
Camcorder Features	
• Quick Review.....	24
• Tape Positioning.....	24
• Microphone.....	24
• Program AE (Auto Exposure).....	24
• Electronic Indexing.....	25
• Time Remaining Display.....	25
Recording Features	
• Electronic Viewfinder.....*	26-27
• Displays in Viewfinder.....	28-29
• Date and Time Display.....	30-31
• Focusing Your Camcorder.....	32-33
• Zooming	
• Power Zoom Buttons.....	34
• Instant Zoom.....	34-35
• Digital Zoom.....	34-35
• 16 x 9 Mode.....	36
• Fading In and Out of Scenes.....	37
• Time Counter with Memory Stop.....	38
• ProEdit® Features	
• Flying Erase Head.....	39
• Edit Search.....	39
• Audio Dubbing.....	40-41
• Audio/Video Dubbing.....	42-43
• Titler.....	44-46
• Recording Tips.....	47
• Recording on Camcorder.....	48-49
Playback	
• Viewfinder Playback.....	50
• Playback Features.....	50-51
• Stop-Action Pause.....	51
• Picture Search.....	51
• Tracking.....	51
• Playback on TV (or VCR) with AUDIO/VIDEO IN Jacks.....	52-53
• Playback on TV without Audio and Video Inputs.....	54-55
Color Enhancement Light	56-57
Attaching the Shoulder Strap	58
Traveling and Cassette Tips	59
Care and Maintenance	60
Specifications	61
User Information	61
Limited Warranty	62
Trouble Checks	63-65
Index (Alphabetical)	66-67

Optional Accessories

We invite you to take a look at some great ideas for sparking creativity and adding to the fun of using your camcorder. These pages have a selection of accessories to help make your memorable moments look and sound even better.

To order accessories, contact your local dealer.

Accessories are available by calling toll-free or by using the order form on page 7.

AC028A Soft Camcorder Case

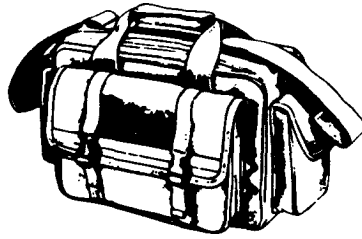

This case provides exceptional protection and utility for full size camcorders and most accessories. It is constructed of rugged, 1000 denier weight, Cordura nylon fabric for years of reliable service and good looks.

Three outside pockets provide ample accessory storage with mesh-covered lens filter compartment and built-in holders for memo pads, pens, and other accessories. The hand grip and adjustable shoulder strap allow for convenient, comfortable transportation of the camcorder.

VCC1000 Video Color Control Center

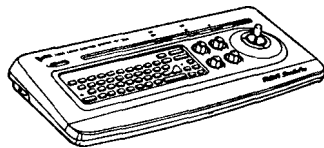

The VCC1000 is two accessories in one. The color control center allows you to adjust the color intensity, tint, white balance, and sharpness of tapes being dubbed. This is especially helpful when the original tape was produced in poor lighting conditions or poor color settings.

The second feature, the character generator, lets you create titles that can be recorded on your tapes. This lets you add a professional and/or personal touch to your home videos.

All specifications and descriptions of accessories are subject to **change** without notice.

DCC096 DC (Battery) Car Cord

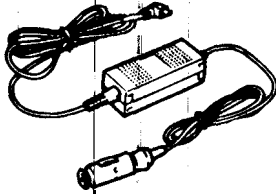

This DC car cord enables you to operate your camcorder from your car, truck, or RV by plugging the car cord directly into the vehicle's cigarette lighter.

Caution: Do not use any other car cord with this camcorder.

CPS014 AC Adapter/Charger

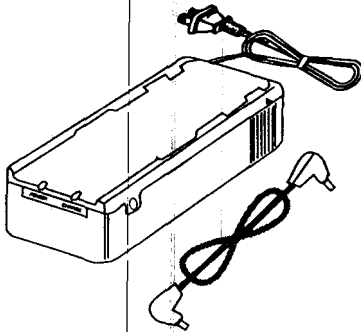

This adapter/charger operates on 100-240 volts, 50/60 Hz, so it can be used almost anywhere in the world to power your camcorder and recharge the **EP096FS** battery supplied with your camcorder.

It also charges the **EP096FL** (2 hour) battery. A simple plug adapter may be required in some countries.

EP096FS and EP096FL Rechargeable Batteries

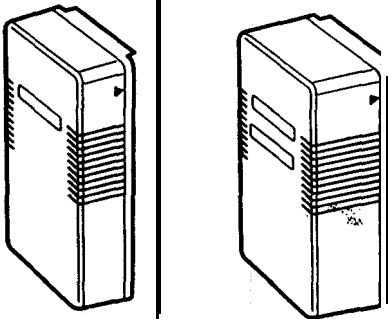

These rechargeable lead-acid batteries are specifically designed for long life. The **EP096FS** can power your camcorder up to one hour and the **EP096FL** up to **two** hours (depending on how much you use the light, zoom, and pause).

Both batteries can be recharged with the AC adapter/charger that came packed with your camcorder. First charging takes approximately two hours for the **EP096FS** and three hours for the **EP096FL**.

(continued on next page)

CRF95 RF Output Adapter

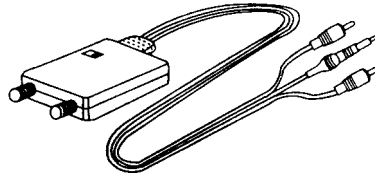

This adapter is used with coaxial RF cable (**AH065G** or **AH066G**) to connect your camcorder to a standard TV (one without audio/video input jacks) for playback. If your antenna cable is the flat twin-lead type attached by two screws, you will also need a 300-75 ohm transformer such as 193983. If your TV, has 300 ohm VHS screw terminals, you will need an optional 75/300 ohm transformer such as AH011.

Coaxial RF Cables



AH065G (6-ft)

AH066G (104-ft)

These RF cables are used with the RF output adapter to connect your camcorder to a standard TV (one without audio/video input jacks) for playback.

If your antenna cable is the flat twin-lead type attached by two screws, you will also need a 300-75 ohm transformer such as 193983.

If your TV has 300 ohm VI-IS screw terminals, you will need an optional 75-300 ohm transformer such as **AH011**.

193983 Cable Transformer



This 300-to-75 ohm transformer is used to connect a standard 300-ohm antenna twin-lead to a standard round 75-ohm connector.

AH011 Cable Transformer



This 75-to-300 ohm transformer is used to connect a standard 75-ohm antenna cable, such as **AH065G** or **AH066G**, to the 300-ohm screw terminals on a TV.

AH25 Y-Adapter



This Y-adapter allows you to connect your camcorder's mono audio cable to a stereo TV or VCR.

(continued on next page)

Removing the Lens Hood

The lens hood can be removed so you can attach optional accessories, such as wide-angle lens, lens extender, or lens filter kit.

To remove the lens hood, place your hand flat against the lens hood and turn it counterclockwise. Do not grasp the end of the lens hood.

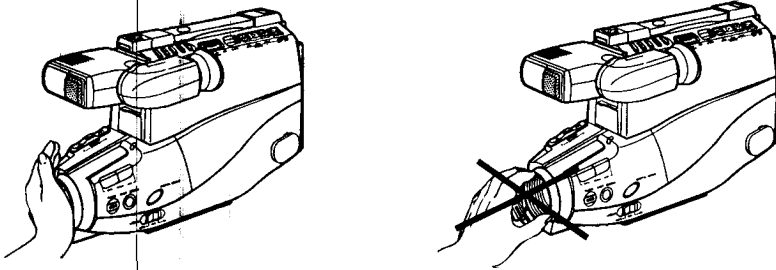

Attaching Accessory Lens

Remove the lens hood as shown above.

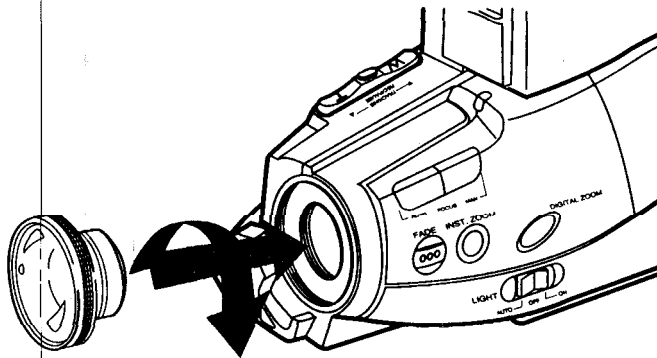

Turn the accessory lens clockwise into the camcorder's lens. Make sure the lens is tightened firmly, but do not over tighten.

All specifications and descriptions of accessories are subject to change without notice.

(continued on next page)

AC093 Tripod

This tripod's fluid-effect head provides smooth camera pan and tilt. The grooved, tubular 3-section leg design folds down to 24.2" when not in use. Rubber feet allow for sure footing.

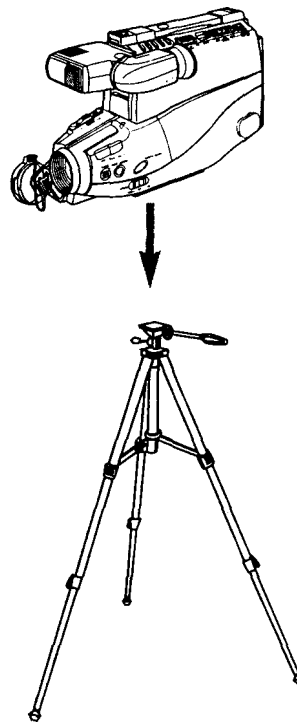

Caution: Before using a tripod, make sure it is stable enough to hold the camcorder without falling over.

When attaching your camcorder to a tripod, be careful not to force the tripod screw into the camcorder's tripod mounting hole.

The tripod screw should not protrude into the camcorder more than approximately three-eighths (3/8) inch. Forcing the screw could damage the mounting hole on the bottom of the camcorder.

All specifications and descriptions of accessories are subject to change without notice.

Accessory Order Form

Order Form for Camcorder Models CC543

Description	Part No.	Price	Qty.	Total
Soft Camcorder Case	AC028A	\$ 89.95		
Tripod	AC093	\$ 59.95		
Cable Transformer	AH011	\$ 1.90		
RF Coaxial Cable (6-ft.)	AH065G	\$ 6.99		
RF Coaxial Cable (10-ft.)	AH066G	\$ 8.99		
Y-Adapter	AH25	\$ 1.95		
Rechargeable Battery	EP096FS	\$ 74.95		
Rechargeable Battery	EP096FL	\$ 89.95		
AC Adapter/Charger	CPS014	\$179.95		
AC Adapter/Charger (Supplied)	CPS019	\$169.95		
RF Output Adapter	CRF95	\$ 49.95		
Car Cord	DCC096	\$ 49.95		
Video Color Control Center	VCC1000	\$349.00		
300-75 Cable Transformer	193983	\$ 6.95		
DC Cable	209342	\$ 12.95		
Shoulder Strap	221243	\$ 13.95		
Audio/Video Cable	221244	\$ 19.95		
Replacement Bulb (4 watt) for Built-in Light	221111	\$ 12.95		

Prices are subject to change without notice.

Total Merchandise (\$10 Minimum Order) \$ _____

Sales Tax \$ _____

We are required by law to collect the appropriate sales tax for each individual state, county, and locality to which the merchandise is being sent.

Shipping, Handling, and Insurance \$ 5.00

Total Amount ^{Final} \$ _____

Use VISA or MasterCard preferably. Money order or check must be in U.S. currency only. No COD or cash.

- ♦ Allow 8 weeks for delivery.
- ♦ All accessories are subject to availability.
- ♦ Where applicable, we will ship a superseding model.

Scissors icon
Detach Here

Please complete other side also

Charge your order on your VISA
or Mastercard by
filling in below

USE YOUR **CREDIT CARD**



IMPORTANT: Copy complete account number
from your VISA card

□ □ □ □ □ □ □ □ □ □ □ □ □ □ □ □

My card expires: **mm**

IMPORTANT: Copy complete account number
from your **MasterCard**



□ □ □ □ □ □ □ □ □ □ □ □ □ □ □ □

Copy Number
above your
name on
MasterCard

□ □ □ □ □

My card
expires:

□ □ □ □ □

AUTHORIZED SIGNATURE

Prices are subject to change without notice.

Print or type your name and
address clearly. This will be your
mailing label.



A complete and correct order will
save you days of waiting.

Name: _____

Street: _____

_____ Apt: _____

City: _____

State: _____ Zip: _____

Detach Here

Please make sure that both sides of this form have
been filled out completely.

Accessory Order Form (continued)

To order accessories, contact your local Dealer.

If a dealer is not nearby, you can also follow the directions below to order by telephone or direct-by-mail.

United States and Canada Orders

To place your order by phone, have your Visa or MasterCard ready and call the toll-free number listed below between 8AM and 8PM Eastern Standard Time. Use this number only to place an order for accessory items listed on this order form.

1 - 800- 338- 0376

Most times your order will be shipped UPS within 72 hours of receipt. If ever it is not possible to ship within 30 days, we will notify you with an update on your order and an option to cancel.

To place your order by mail, detach and mail the completed order form with credit card information, money order, or check in U.S. currency (made payable to Thomson Consumer Electronics, Inc.) to the following address:

Video Accessories
PO Box 8419
Ronks, PA 17573

For more information on these accessories (or current prices), write to the following address:

Video Accessories Customer Service
Thomson Consumer Electronics, Inc.
Distributor & Special Products
2000 Clements Bridge Rd
Deptford, NJ 08096-2088

International Orders

This offer is valid only in the United States and Canada. For international orders, please send your request for a price quotation (not an order) to:

International Customer Service
Thomson Consumer Electronics, Inc.
Distributor & Special Products
2000 Clements Bridge Rd
Deptford, NJ USA 08096-2088

First-Time Operation

1. Unpack the camcorder and accessories.

- Save the box and packing materials in case you ever need to store or ship your camcorder.
- The items shown below are packed with your camcorder. If any of them are missing or appear damaged, contact your dealer immediately.

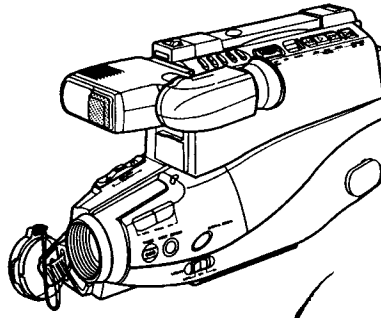

Camcorder
Model CC543

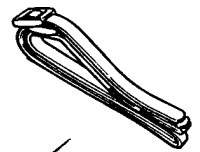

Shoulder Strap
Stock No. 221243

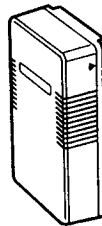

Rechargeable 10-Volt Battery
Stock No. EP096FS

**WARNING:
LEAD-ACID
BATTERY.
MUST BE
DISPOSED OF
PROPERLY.**

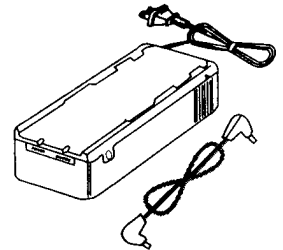

AC Adapter/Charger
Stock No. CPS019
DC Cable Stock No. 209342

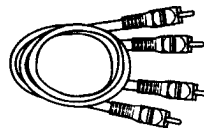

Audio/Video Cable
Stock No. 221244

2. Attach a power supply.

Attach the adapter/charger or charged battery.

Adapter/Charger

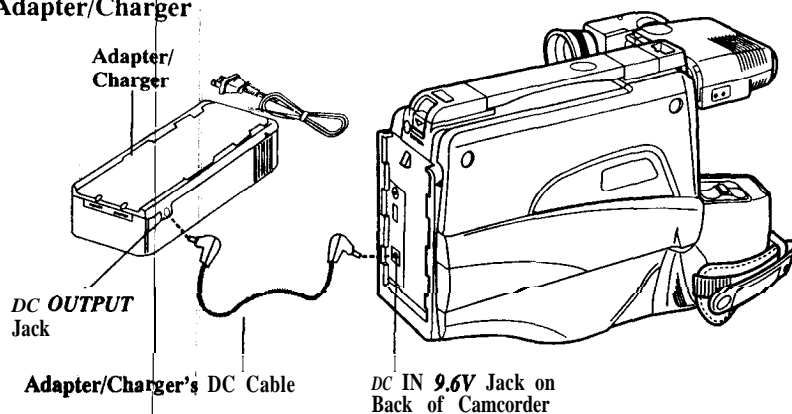

- Attach one end of the adapter/charger's DC cable to **DC OUTPUT** jack on adapter/charger.
- Attach the other end of the cable to the **DC IN 9.6V** jack on the camcorder.
- Plug the adapter/charger's plug into an operating outlet.
- *Details are on page 16.*

Charged Battery*

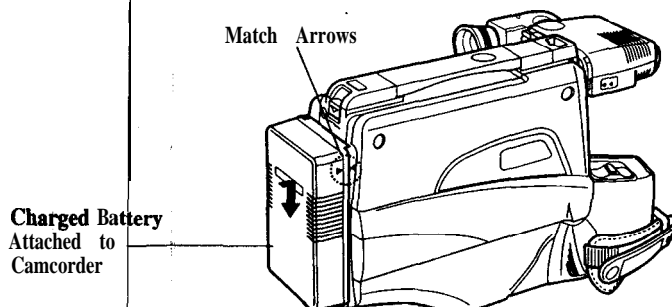

- Match the **arrow** on the battery to the arrow on the camcorder.
- Hold the battery **flush against the** camcorder and slide it down.
- *Details are on pages 17-18.*

* The battery must be charged before it can be used the first time.

(continued on next page)

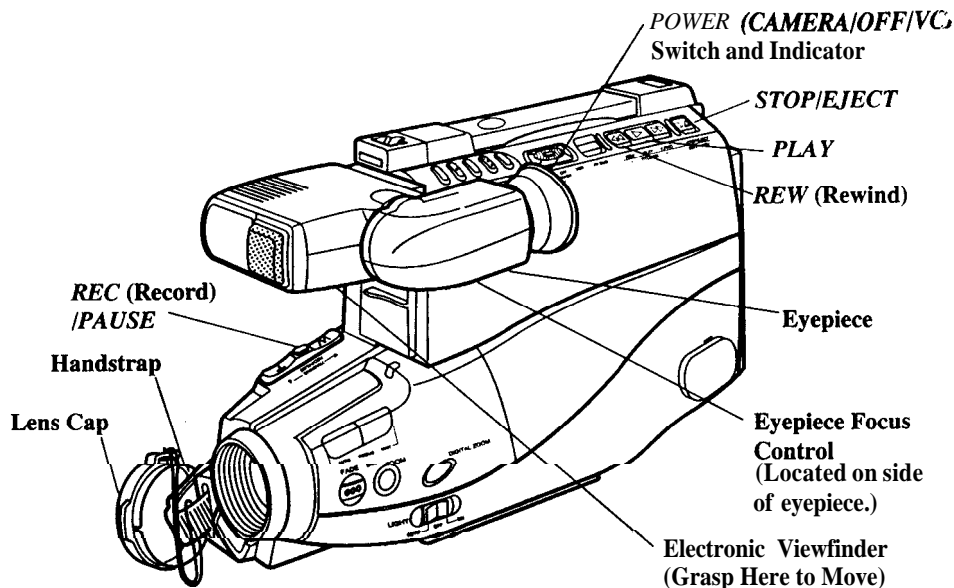

3. Remove the lens cap and attach it to the handstrap.

4. Turn on the camcorder.

The position of the *POWER (CAMERA/OFF/VCR)* switch tells the camcorder whether you want to record (*CAMERA*), play back tapes (*VCR*), or turn off the power (*OFF*).

- Press and hold small button on *POWER* while sliding it in *CAMERA*. The *POWER* indicator will light when the camcorder is turned on.

5. Insert a cassette.

- Press *STOP/EJECT* to open the cassette compartment.
- Insert the cassette with the safety tab facing up and the tape windows facing out.

- Press the cassette down gently until it locks into place, and close the cassette compartment door.
- *Details are on page 23.*

6. Position viewfinder and adjust eyepiece focus control.

- Grasp the viewfinder and rotate it horizontally.
- Pull the viewfinder out from the camcorder and rotate the eyepiece into a comfortable viewing position.
Caution: Pulling on the eyepiece may cause damage to the eyepiece or camcorder.
- If the image in the viewfinder is blurry, adjust the eyepiece focus control for your vision. *Details are on page 26.*

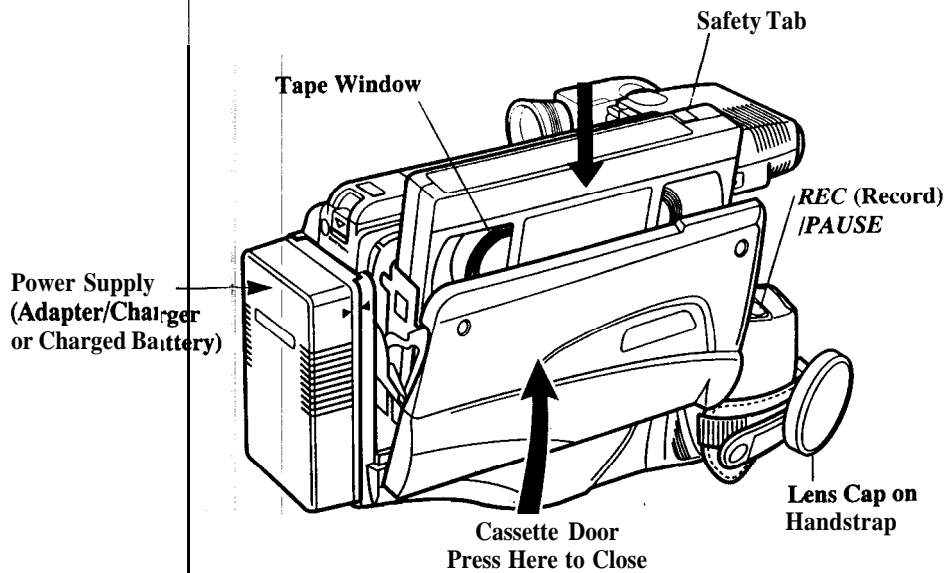

7. Start and stop recording.

Start and stop recording by pressing and releasing **REC/PAUSE**. **REC** appears in the viewfinder. You do not have to hold the button to record.

Notes: If you do not record within five minutes, the camcorder will automatically shut off to prevent excessive tape wear. Press **REC/PAUSE** to turn on the camcorder.

Any material recorded on the tape will automatically be erased if you record over it.

8. Play back what you have recorded.

- Press **REC/PAUSE** to stop recording.
- Press and hold the small button on **POWER** while sliding it in **VCR**.
- Press **REW** (rewind) to rewind the tape.
- Press **PLAY** to play back the tape in the viewfinder.
- Press **STOP/EJECT** when you are finished playing back the tape.
- *Details on viewfinder playback are on page 50.*

(continued on next page)

9. Review the camcorder's operating controls.

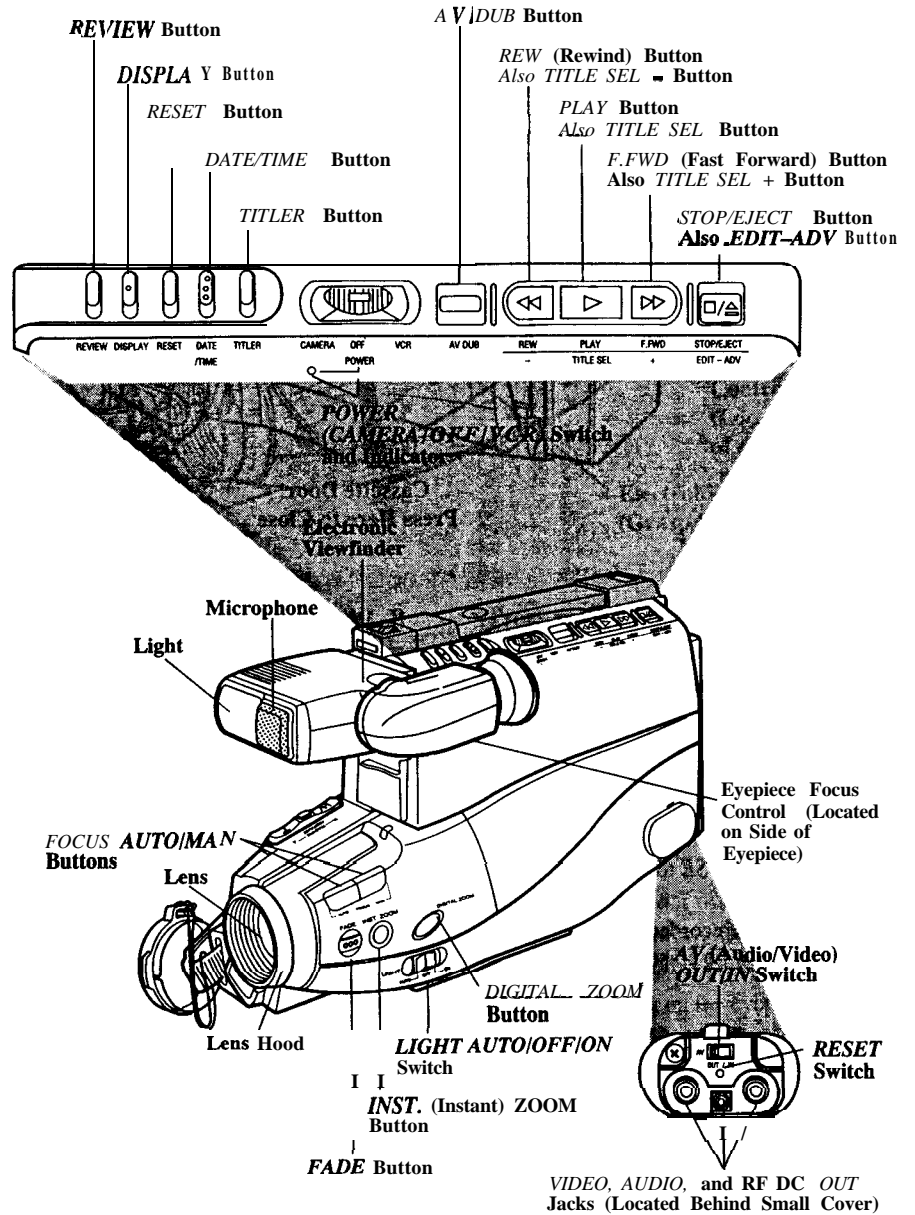

9. Review the camcorder's operating controls. (continued)

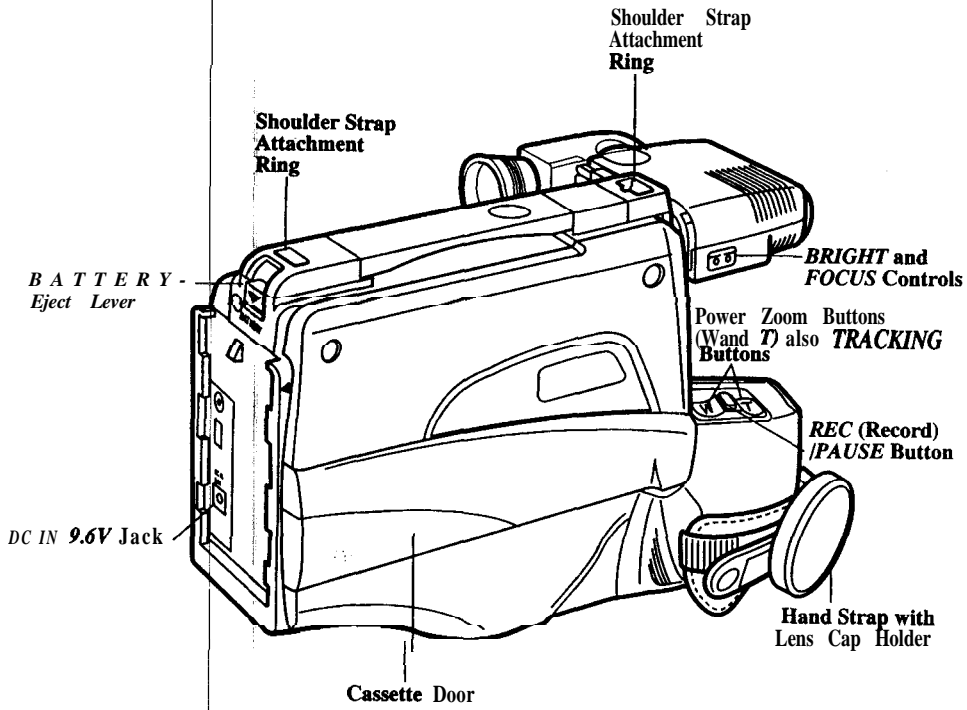

(continued on next page)

Powering the Camcorder

Caution: Do not attempt to use a "power converter" to use your AC adapter/charger on a power source other than 120 volts, 50/60 Hz, or the adapter/charger and camcorder may be damaged. If you wish to operate the AC adapter/charger on a power source other than 120 volts, 50/60 Hz, use only a transformer-type power converter. Do not use "solid-state" or "switching-type" power converters. They will damage your AC adapter/charger. An optional CPS014 shown on page 3 is designed for use on 100-240 volts, 50/60 Hz.

Using the Adapter/Charger to Power Your Camcorder

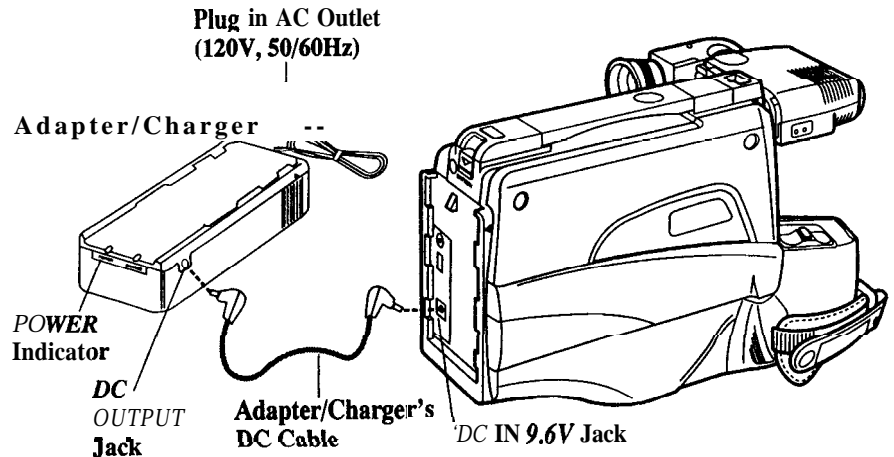

1. Connect one end of the adapter/charger's cable to the adapter/charger's DC OUTPUT jack and the other end to the DC IN 9.6V jack on the back of the camcorder.
2. Plug the adapter/charger into the nearest AC outlet (120V, 50/60 Hz).
3. The POWER indicator on the adapter/charger will light when it is properly connected.

Notes: The adapter/charger cannot charge the battery and operate the camcorder at the same time. If you connect both, the adapter/charger will power the camcorder. Remove the adapter/charger's cable from the DC OUTPUT jack to charge the battery.

When using the adapter/charger to power the camcorder, the battery level indicator may display . This indicator is used for battery operation and has no meaning when using the adapter/charger to power the camcorder.

To Remove the Adapter/Charger

1. Remove the adapter/charger's plug from the AC outlet.
2. Remove the adapter/charger's DC cable from the DC IN 9.6V jack on the camcorder.

Caution: Do not use this adapter/charger for any purpose other than charging the EP096FS, EP096FL, CB096FS, or CB096FL battery pack or supplying power to the camcorder.

Using the Battery to Power Your Camcorder

Charging the Battery

The battery must be charged before it can be used the first time. Charging will take approximately two hours depending on the condition of the battery. When fully charged, the battery should supply approximately 60 minutes of operating time (depending on how much you use zoom and pause). To extend the battery's operation time, turn off the camcorder's power when not in use.

WARNING: LEAD-ACID BATTERY. MUST BE DISPOSED OF PROPERLY.

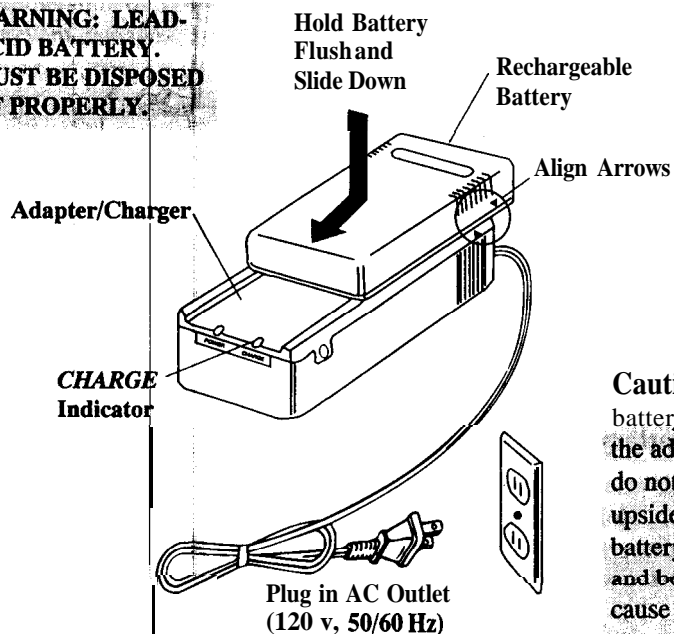

Caution: When a battery is attached to the adapter/charger, do not turn them upside down. The battery may fall off and be damaged or cause injury.

1. Attach the battery to the adapter/charger as shown. Align the reference arrow on the battery with the arrow on the adapter/charger. Hold the battery flush against the adapter/charger and slide it in the direction of the arrow.
Note: You cannot charge the battery and operate the camcorder from the adapter/charger at the same time. Remove the adapter/charger's DC cable from the camcorder to charge the battery.
2. Plug the adapter/charger into the nearest AC outlet (120 V, 50/60 Hz).
3. The **CHARGE** indicator will light while the battery is being charged. When the indicator turns off, the battery is fully charged.
4. Remove the battery from the adapter/charger by sliding the battery up and off.
5. Attach the charged battery to the camcorder as shown on the next page.

(continued on next page)

Using the Battery to Power Your Camcorder (continued)

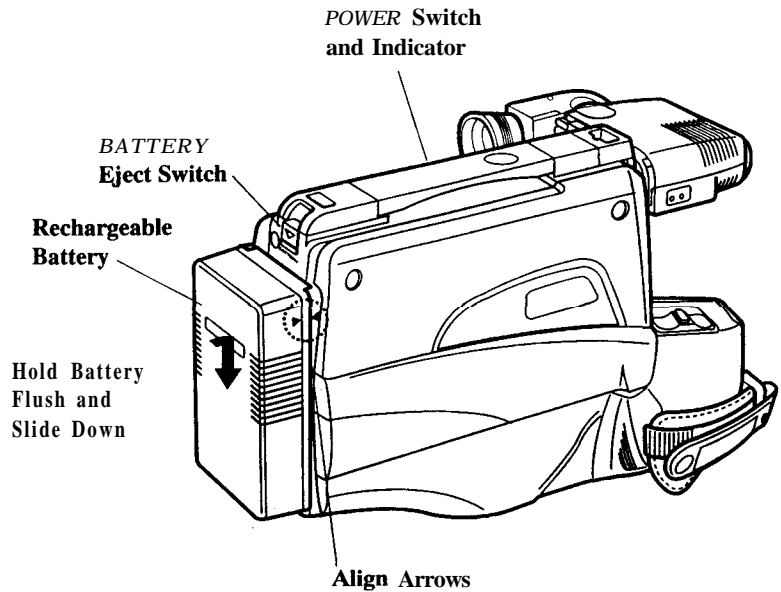

Attach Charged Battery

1. Align reference arrow on battery with arrow on camcorder. Hold battery flush against camcorder while sliding it down in the direction of the arrow as shown.
2. Press and hold small button on *POWER* while placing it in *CAMERA*. *POWER* indicator will light if battery is properly attached.

Remove the Battery

1. Slide *POWER* to *OFF*. *POWER* indicator will turn off.
2. Press and hold *BATTERY* eject while sliding battery up and off the camcorder.

ATTENTION: THE PRODUCT THAT YOU HAVE PURCHASED USES A RECHARGEABLE BATTERY. AT THE END OF ITS USEFUL LIFE, UNDER VARIOUS STATE AND LOCAL LAWS, IT MAY BE ILLEGAL TO DISPOSE OF THIS BATTERY INTO THE MUNICIPAL WASTE STREAM. CHECK WITH YOUR LOCAL SOLID WASTE OFFICIALS FOR DETAILS IN YOUR AREA FOR RECYCLING OPTIONS OR PROPER DISPOSAL.



Pb

Using the Battery to Power Your Camcorder (continued)

Battery Care

- Your battery will provide better service and longer performance if you charge it before and after use, and store it at normal room temperature.
- The battery should be charged at a temperature of 32°F-95°F (0°C-35°C) to prevent damage.
- Do not operate the battery at temperatures below 14°F (-10°C) or above 95°F (35°C). The battery may be damaged if operated at temperatures above 122°F (50°C). Operation time will decrease at extremely low temperatures.
- After repeated chargings and use, the operation time will gradually decrease. When operation time becomes too short to be useful, it is time to replace the battery.

Battery Storage

- Store the battery at normal room temperature.
- Lead acid batteries discharge if not used. Recharge the battery at least once every six months or you may not be able to recharge it.
- A battery stored for a long period may not supply power for the specified time. Additional **rechargings** may help restore the battery's operation time.

Battery Safety Precautions

Batteries being recharged that have not been used for an extended period may continue to charge after the normal time. Do not charge a battery for more than 24 hours.

If both indicators on the adapter/charger start flashing, remove the battery, and reattach it. If after several attempts — the indicators continue to flash — your battery cannot take a charge and must be replaced.

Throwing the battery into a fire or exposing the battery to excessive heat — over 149° F (65° C) could be hazardous.

Do not short the battery's terminals.

Allow battery to cool down before attaching it to adapter/charger. The **CHARGE** indicator will not light and the battery will not charge if you attach a hot battery.

Do not attempt to disassemble or modify the battery. There are no user-serviceable parts inside.

Use the battery only with specified AC adapter/chargers and camcorders.

If leakage from a damaged battery contacts your skin or clothing, wash it off immediately with running water.

(continued on next page)

Check Battery Power (Battery Level Indicators)

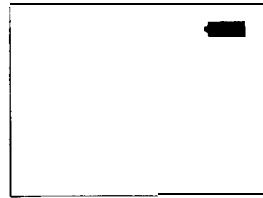



Battery Level Indicator
Display in Viewfinder

The battery level indicator () appears in the camcorder's viewfinder when *POWER* is in *CAMERA* to show how much battery power is left in the rechargeable battery.

This indicator is not recorded on the tape.

- When the battery is fully charged, the display shows .

- After a while, only  appears.
- When the battery reaches the empty level,  will start flashing. Recharge the battery or attach the adapter/charger before continuing to use the camcorder.

Note: The battery level indicator has no meaning when you power the camcorder with the adapter/charger or optional car cord.

Caution: When the battery reaches its empty level during use, the camcorder will turn off. However, the battery should have enough reserve power to eject the cassette when you press *STOP/EJECT*.

If the camcorder does not eject the cassette when you press *STOP/EJECT*, do not force the cassette door open. This will damage your camcorder.

Before attempting to eject the cassette, power your camcorder with the adapter/charger or recharge the battery.

Using the Optional Thomson Car Cord Adapter

To power your camcorder from the cigarette lighter socket of a car, truck, or RV, you need the optional car cord adapter DCC096 shown on page 3.

The DCC096 car cord is especially designed to convert power from a 12-volt battery to the 9.6-volt input jack on the camcorder.

Caution: The DCC096 car cord is designed to be used only with vehicles having 12-volt negative ground electrical systems.

Warning: To avoid possible damage to your camcorder, use only the DCC096. It has positive tip polarity and is capable of converting 12-volts to 9.6 volts.

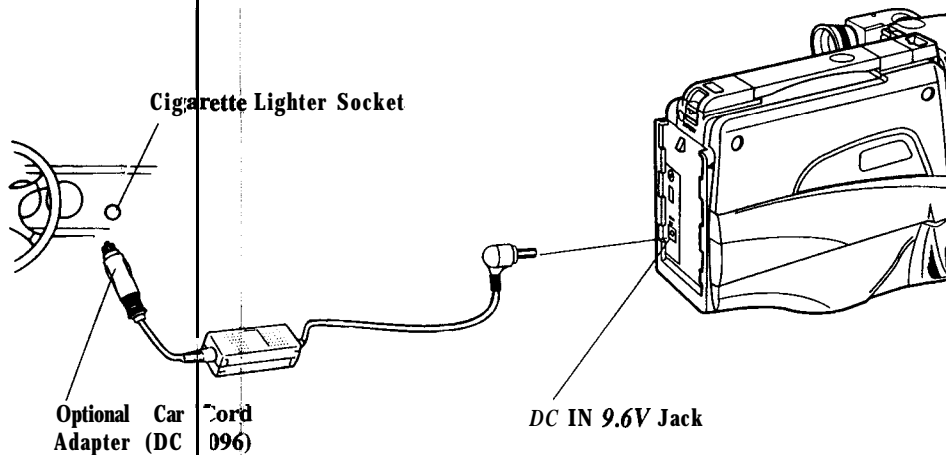

1. Remove the adapter's DC cable or battery from the camcorder, if either is attached.
2. Connect the small plug on the car cord to the DC IN 9.6V jack located on the back of the camcorder.
3. Insert the other end of the car cord into the vehicle's cigarette lighter socket.
4. Place the camcorder's POWER switch in CAMERA. If the car cord is connected properly, the POWER indicator will light.

Notes: The vehicle does not have to be turned on for the camcorder to operate from the DC car cord.

When using the car cord to power the camcorder, the battery level indicator may display . This indicator is used for battery operation and has no meaning when using the car cord to power the camcorder.

Video Cassettes

We recommend that our cassettes be used with your camcorder. Use of poor quality tapes or tapes that have been damaged or mishandled can contaminate the video heads, resulting in a snowy picture or no picture at all during playback. Because there is no control over the type of tape purchased or rented by consumers, **head cleaning is not covered under warranty**. It is considered normal maintenance.

If a snowy picture or no-picture condition persists, consider the use of a dry chemical non-abrasive head-cleaning tape. Be sure to follow the directions with the head-cleaning kit carefully. Improper use of a head cleaner may damage your camcorder.

Erase Protection -Safety Tab

You can use your video cassettes over and over again. To erase a previous recording, just record over it.

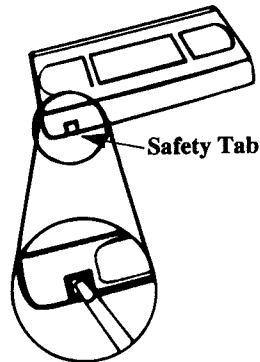

To prevent accidental erasure, break the tab.

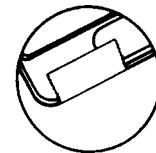

To record again, cover the hole with vinyl tape.

Recording Times

The camcorder records and plays back in VHS standard speed (SP). The chart shows the maximum SP recording times for popular VHS cassettes.

CASSETTE	RECORDING TIME
T-60	60 Min.
T-120	2 Hrs.
T-160	2 Hrs., 40 Min.
T-180	3 Hrs.

Inserting and Removing Cassettes

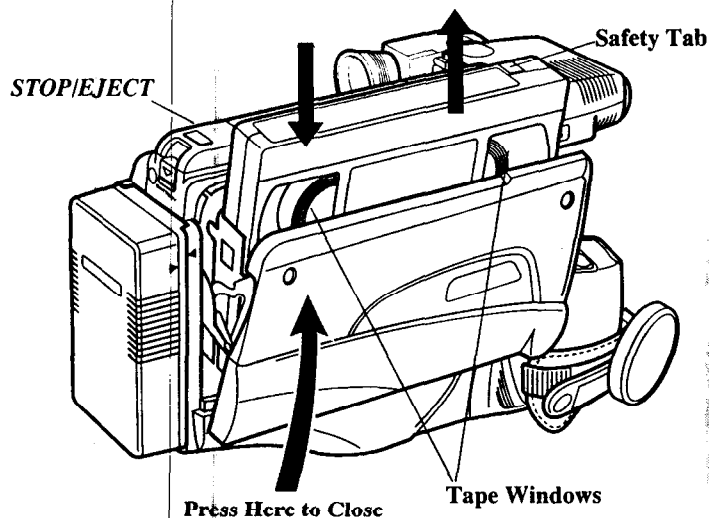

Caution: Insert cassette with safety tab facing up and tape windows facing out. Cassette should slide easily into the compartment. Gently push the cassette down until it locks into place.

1. Attach a power source to the camcorder (either a charged battery or adapter/charger).
2. Press *STOP/EJECT* on the top of the camcorder to open cassette door.
3. Insert or remove the cassette from the cassette compartment.
4. Gently close the cassette door with your hand.

Cassette Care and Storage

Follow these directions for continued high-quality performance from your cassettes.

- When you are finished with a cassette, rewind it and remove it from the camcorder.
- Label and store cassettes vertically in their protective cases at normal room temperatures. Excessive heat or cold may damage your cassettes.
- Keep dust from entering the cassette compartment. All dust is abrasive and will cause excessive wear on the tape and the camcorder's recording or playback heads.
- Keep cassettes away from strong magnetic fields, such as electric motors and other devices.
- Do not use a cassette if it has been damaged or exposed to moisture. The tape may jam or damage the camcorder.
- When you are finished recording, break off the safety tab on the cassette to prevent accidental erasure.
- Do not leave your camcorder or cassettes in a car or outdoors for an extended period. Excessive heat or cold may damage them.

Camcorder Features

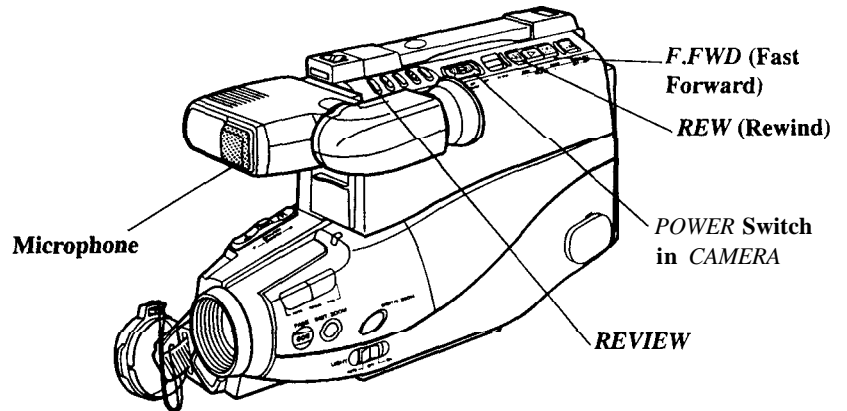

Quick Review

Press **REVIEW** when **POWER** is in **CAMERA** and the camcorder is in record pause to review the last few seconds of a recording.

The camcorder will play back the last few seconds of the recording, return the tape to its previous position, and return to record pause.

Note: Noise bars may appear during this feature.

Tape Positioning

When **POWER** is in **VCR** and the camcorder is in the stop mode, you can quickly fast-forward or rewind the tape.

- Press **F.FWD** (fast forward) to fast forward the tape. Press **STOP/EJECT** to stop fast-forwarding.
- Press **REW** (rewind) to rewind the tape to the beginning. Press **STOP/EJECT** to stop rewinding.

Microphone

The microphone picks up sound during a recording. It is more sensitive to sounds coming from the direction the lens is pointed.

Program AE (Auto Exposure)

Program auto exposure automatically selects the shutter speed and adjusts the iris according to the shutter speed.

The AE indicator for the shutter speed selected (**1/60**, **1/100**, **1/120**, **1/180**, **1/250**, **1/350**, **1/500**, **1/750**, **1/1000**, **1/1500**, **1/2000**, or **1/4000** second) appears in the viewfinder.

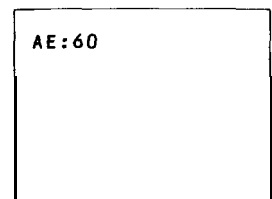

Viewfinder Display

Electronic Indexing

Each time you begin recording (after the camcorder has been turned off for at least four hours), the camcorder will automatically record an index mark at the beginning of the new recording.

When you play back the indexed tape in a VCR that has a compatible indexing feature called "VHS Index Search System", the invisible marks can be located automatically. See your VCR owner's manual for index playback instructions.



Viewfinder Display

INDEX will appear briefly in the viewfinder to let you know the camcorder is recording an index mark.

Note: The camcorder does not record index marks every time you stop and start recording. An index mark is recorded only **once** — at the start of each day's recording session (or whenever the camcorder has been turned off for at least four hours).

Time Remaining Display

The time remaining display shows the amount of recording or playback time left on the tape in the camcorder.

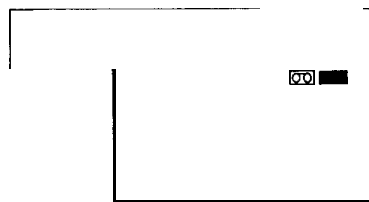

Viewfinder Display

"-----" will appear for approximately ten seconds when you first start playing or recording a tape while the camcorder calculates the time remaining.

Once time remaining has been calculated, it will automatically be updated and readily available as long as the same tape remains in the camcorder.

Electronic Viewfinder

The camcorder's electronic viewfinder is a miniature monitor that displays the picture seen by the camcorder when recording. The viewfinder also can be used for viewing the tape during playback.

When carrying or storing the camcorder, return the viewfinder to the original position to prevent possible damage.

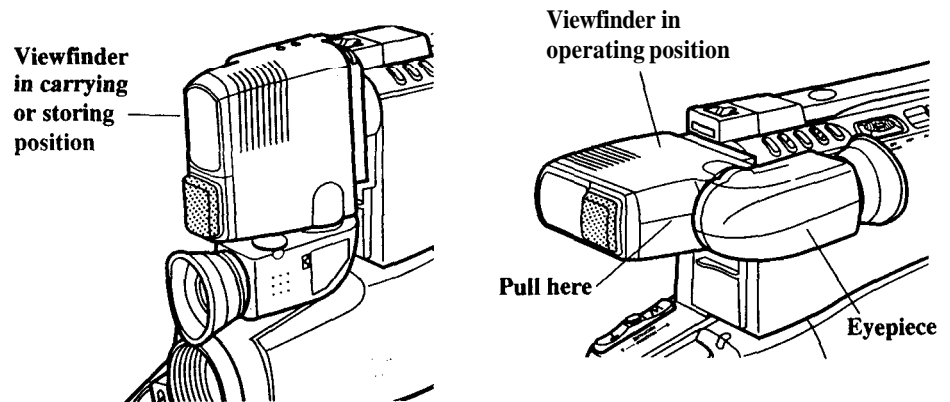

Caution: Pulling on the eyepiece may cause damage to the camcorder.

1. Grasp the viewfinder and rotate it horizontally.
2. Pull the viewfinder out from the camcorder and adjust the eyepiece for convenient viewing.

Eyepiece Focus Control

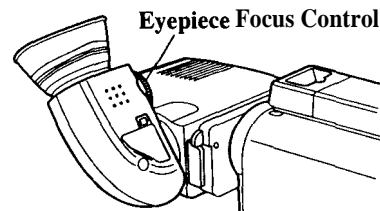

The eyepiece focus control lets you set the focus of the viewfinder for your personal vision. If you wear eyeglasses, you probably can operate the camcorder without them.

Set the correct focus by focusing on one of the viewfinder's displays (such as the counter). Look through the viewfinder, and adjust the eyepiece focus control for your vision.

The eyepiece focus control does not affect the focus of the picture actually recorded by the camcorder.

Eyepiece **BRIGHT** and **FOCUS** Controls

BRIGHT
FOCUS---

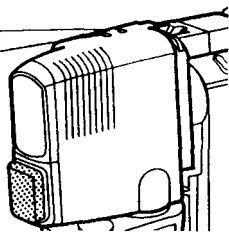

BRIGHT and FOCUS Controls

The small **BRIGHT** and **FOCUS** controls are set at the factory and should require no adjustment. If they ever require adjustment, use a plastic screwdriver. Make the adjustments with caution to prevent damaging the miniature controls.

Tilt Adjustment

For convenient viewing, you can rotate the eyepiece about 225° degrees.

Rotate up to 225°

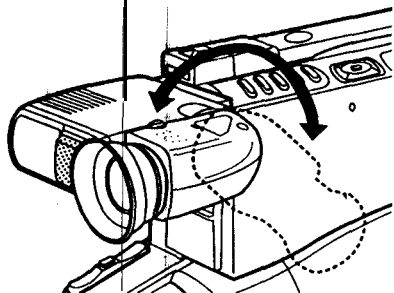

Caution: Do not force the eyepiece to rotate completely around. This will damage the eyepiece, viewfinder, and/or camcorder.

Cleaning the Viewfinder

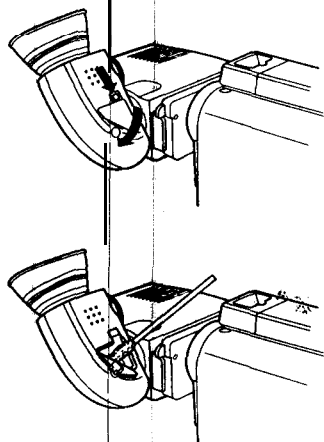

1. Depress tab to open small cover.

Caution: Do not force the cover to open completely. This could damage the cover.

2. Gently use a cotton swab and clean the mirror inside viewfinder.
3. Gently close cover until tab snaps in place.

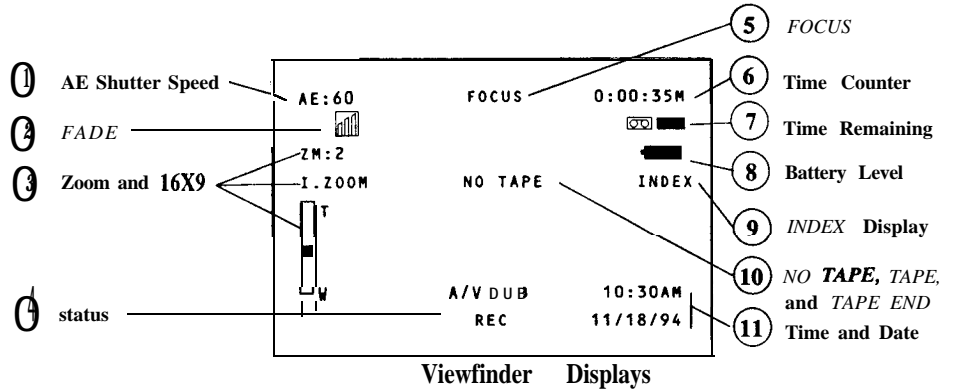

1 AE (Auto Exposure) Shutter Speed

The shutter speed selected by the camcorder appears here. It is not recorded on the tape.

2 Fade

Press *FADE* to select white, wipe, or zoom fade. It is not recorded on the tape.

- appears for white fade.
- appears for wipe fade.
- appears for zoom fade.

• Details are on page 37.

3 Zoom and 16X9

Press *DIGITAL ZOOM* to select a digital zoom mode. The mode selected appears. It is not recorded on the tape.

- Select **ZM:2** to activate the extended zoom mode -wide angle to 100X.
- Select **16X9** to make a recording that will be played back on a 16 x 9 wide screen TV.
- ZOOM appears when you press power zoom button *T* and zoom in the telephoto direction more than 12 times.
- *I.ZOOM* appears when you press *INST. ZOOM* to enlarge the picture 1.5 times.

- The zoom level indicator appears when you press power zoom button *T* or *W*.
- Details are on pages 34-36.

4 ..∞..

The following displays appear in these area. They are not recorded on the tape.

- *AIV DUB* for audio/video dubbing.
- *A. DUB* for audio dubbing.
- REC for recording.
- during fast forward.
- during rewind.
- *II* during record pause.

5 FOCUS

Press both *FOCUS* buttons together to turn auto focus on or off.

- No indicator appears during auto focus.
- *FOCUS* appears when manual focus is turned on. It is not recorded on the tape.
- Details are on pages 32-33.

6 Time Counter with Memory Stop (M)

The time counter shows the actual amount of elapsed recording or playback time. It is not recorded on the tape.

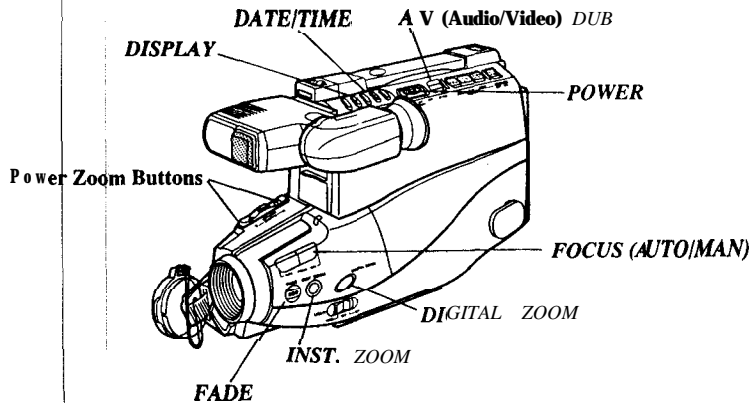

• Press **DISPLAY** to turn memory stop on or off.

• *Details are on page 38.*

7 Time Remaining ([] j)

This display shows the amount of recording or playback time remaining on the tape. It is not recorded on the tape. *Details are on page 25.*

8 Battery Level ([])

This indicator shows the amount of time left for the rechargeable battery. It is not recorded on the tape. *Details are on page 20.*

9 INDEX

INDEX appears briefly when the camcorder automatically indexes the tape. It is not recorded on the tape. *Details are on page 25.*

10 TAPE, NO TAPE, and TAPE END

- **TAPE** flashes when you try to record and the safety tab has been removed.
- **TAPE** flashes when a damaged tape is inserted. Remove the tape and replace it with a new one.

• **TAPE** flashes when a tape is inserted in the camcorder and moisture is present. Moisture may develop when the camcorder is moved from a cold area to a warm area. Remove the tape and wait an hour before reinserting.

• **NO TAPE** flashes when you try to record and there is no cassette in the camcorder.

• **TAPE END** flashes when you have approximately three minutes recording time left on the cassette.

• **TAPE END** briefly appears when you reach the end of the cassette during recording.

• These displays are not recorded when they appear.

11 Time and Date Display

• Press **DATE/TIME** repeatedly to display time and date, **AUTO** date, date only, or no date display when the camcorder is in record pause.

• These displays are recorded when they appear.

• *Details are on pages 30-31.*

Date and Time Display

Set the Time and Date

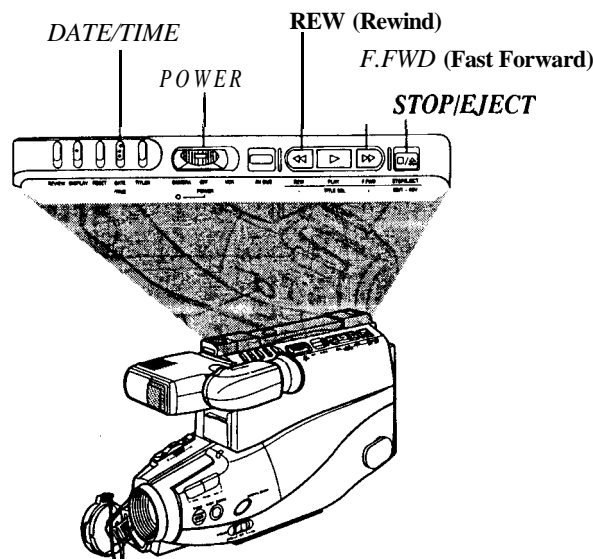

1. Attach a power supply (battery or adapter/charger) to the camcorder.
2. Press and hold the small button on *POWER* and place in *CAMERA*.
3. Press *DATE/TIME* to display the date and time in the viewfinder. A flashing cursor lets you know which part of the display you are setting.
5. When the correct digit is displayed, press *STOP/EJECT*. The cursor will move to the next part of the display.
6. Repeat steps 4 and 5 to set the correct month, day, year, hour, minute(s), and *AM/PM*.
7. After setting *AM* or *PM*, press *DATE/TIME* to remove the flashing cursor and start the internal clock.

Note: If flashing cursor does not appear, press and hold *DATE/TIME* and then press *STOP/EJECT*.

To Correct the Date or Time

To correct the date or time, press and hold *DATE/TIME* and then press *STOP/EJECT*. The display will appear in the viewfinder along with the flashing cursor. Use *F.FWD* and *REW* to correct the time or date. Press *DATE/TIME* to remove the flashing cursor and start the clock.

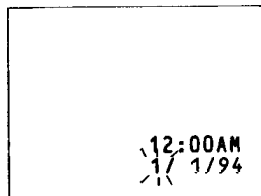

4. Repeatedly press *F.FWD* or *REW* until correct month appears. Press and hold the button to advance the digits faster.

(continued on next page)

Date and Time Display (continued)

Recording Date and Time (or Date) on Your Tape

The time and date: (or date only) can be recorded on your tape. Whenever one of the displays appears in the viewfinder, it will be recorded.

The camcorder has an /auto-date feature that will record the date only for approximately ten seconds when you begin recording.

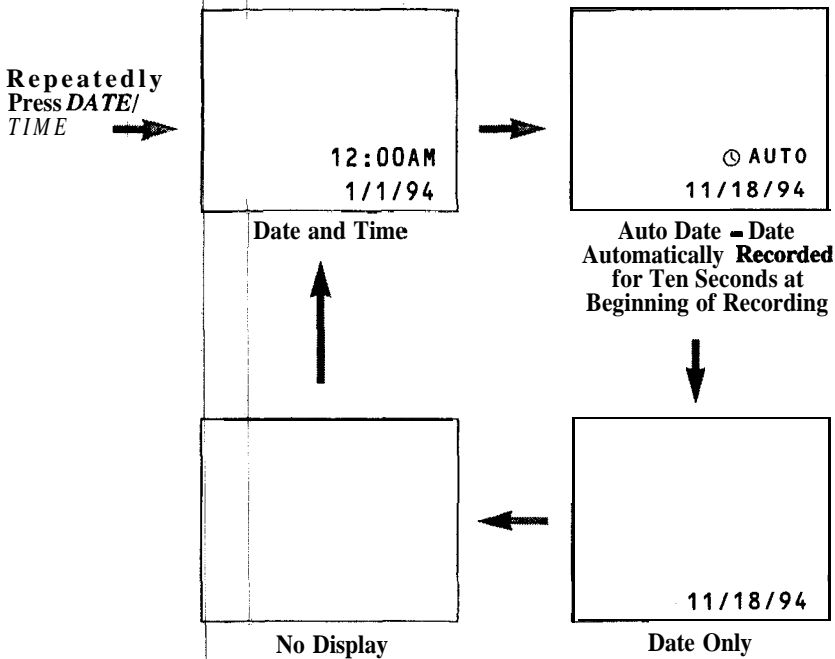

Charging the Camcorder's Built-in Clock Battery

The camcorder has a built-in rechargeable clock battery.

This battery must be charged approximately every two months.

1. Attach a power supply (adapter/charger or charged battery) to the camcorder.
2. Make sure **POWER** is in **OFF**.
3. Leave the power supply attached at least 24 hours.

Cautions: If this battery is not charged every two months, it will over-discharge and shorten its useful life.

Do not attempt to replace this battery. Take the camcorder to an authorized Servicer.

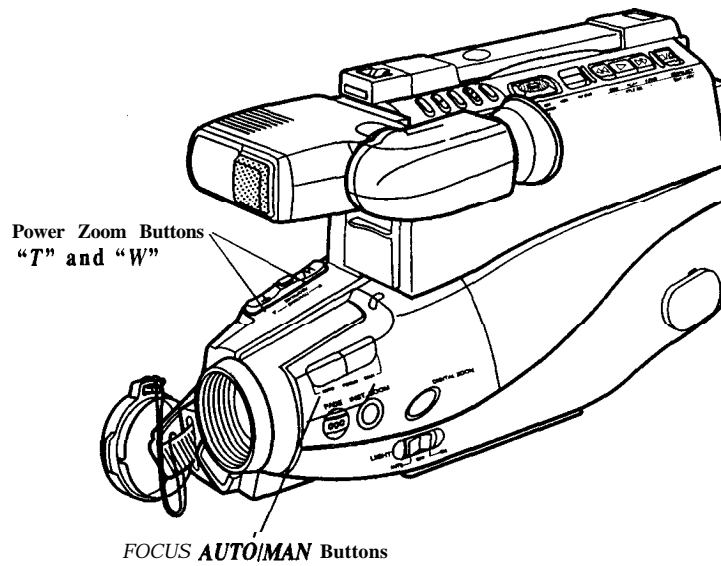

Auto Focus

The camcorder will focus automatically whenever *FOCUS* does not appear in the viewfinder.

- If *FOCUS* appears, press both *FOCUS AUTO/MAN* buttons at the same time to turn on auto focus.

The camcorder will automatically focus on the subject in the center of the viewfinder.

Auto focus will operate on the telephoto "**T**" side from approximately 3.6 feet to infinity.

Auto focus will operate on the **wide-angle** "**W**" side 1.2 inches from the lens surface to infinity.

Manual Focus

Under certain conditions, such as those listed, you may need to focus manually.

1. Press both *FOCUS AUTO/MAN* buttons at the same time to turn on manual focus. *FOCUS* appears in the viewfinder.

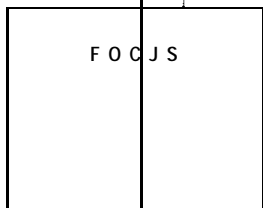

2. Press zoom button *T* to zoom in on your subject.
To maintain proper focus throughout the zoom range, zoom in on your subject before adjusting the focus.
3. Press and hold either *FOCUS AUTO/MAN* button until the subject is clearly focused.
4. When you are finished, press both *FOCUS AUTO/MAN* buttons at the same time to turn on auto focus. *FOCUS* disappears from the viewfinder.

Conditions that May Require Manual Focus

The following conditions may require the use of manual focusing during recording.

- When a subject has a close foreground and a background far away.
- When two subjects at different distances overlap.
- A subject with distinct horizontal stripes or small pattern.
- A subject not in the center of the viewfinder.
- Subjects with shiny surfaces or sharp angles.
- Recording in low-light situations.
- Recording through a window.

Macro Focus

The macro-focus feature lets you focus on objects as close as 1.2 inches from the camcorder lens.

1. Make sure *FOCUS* does not appear in the viewfinder. If it does, press both *FOCUS AUTO/MAN* buttons at the same time to remove it.
2. Press and hold zoom button "*W*" until the lens is completely zoomed out.
3. Position the subject in the center of the viewfinder.

Notes: Zooming is not possible when using macro focus. To change the size of the subject, move the camcorder's lens closer or farther away from it.

For best results, increase illumination when recording using macro focus.

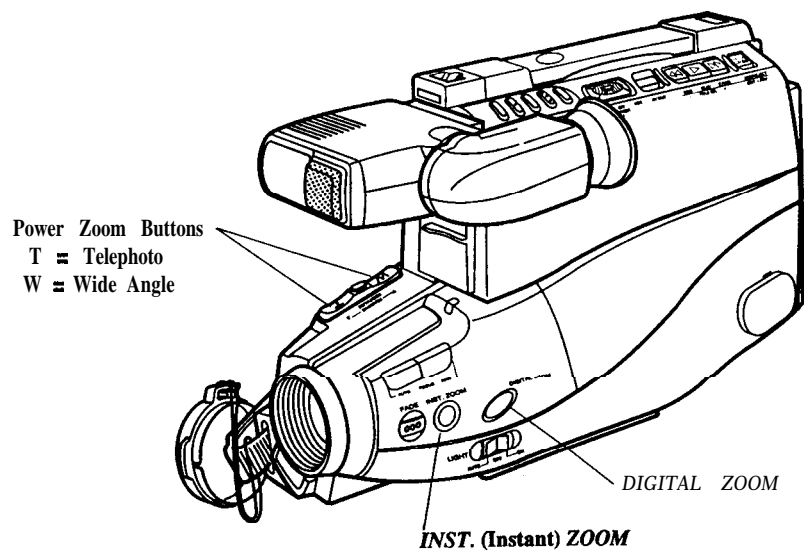

Using Power Zoom Buttons

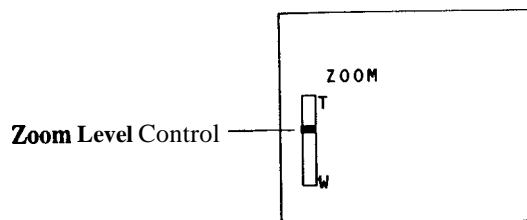

To zoom in or out slowly, press the zoom button lightly. To zoom in or out quickly, press the zoom button **firmly**.

- Press “**T**” to move the lens in the “telephoto” (close-up) direction.
- Press “**W**” to move the lens in the “wide-angle” direction.

The zoom level indicator will appear briefly in the viewfinder.

When the zoom ratio goes above 12 times, ZOOM appears in the viewfinder.

(continued on next page)

Using *INST.* (Instant) ZOOM

Instant Zoom
Indicator

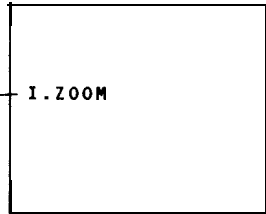

- Press *INST. ZOOM* to magnify the subject 1.5 times regardless of the position of the power zoom buttons. *I.ZOOM* appears in the viewfinder during instant zoom.
- Press *INST. ZOOM* again to turn off instant zoom.

Digital Zooming

The digital zoom feature allows you to zoom in on a subject with magnification of up to 100 times.

Digital Zoom
Indicator

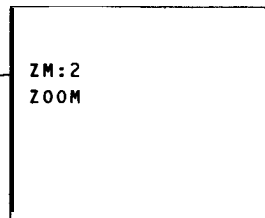

1. Repeatedly press *DIGITAL ZOOM* to select the digital zoom mode.
 - The normal zoom mode is wide angle to 12 times. No display appears in the viewfinder.
 - Select *ZM:2* to activate the extended zoom mode — from wide angle to 100 times for special effects.
 - Select *16X9* to make a recording that will be played back on a 16 X 9 TV. See next page for details.
 2. Press power zoom button "W" or "T" to control the digital zoom ratio.
- Notes: *ZOOM* appears in the **viewfinder** for zoom levels above 12X. It will not be recorded on the tape.
- As the zoom level increases in the *ZM:2* mode, the picture will gradually become less sharp. Extremely high zoom levels are used mainly for special effects.

16X9 Mode

The new 16 x 9 TV format provides a 30% wider picture than conventional TVs of the same height. The 16 x 9 recording mode lets **you** make recordings compatible with this new format. When the 16 x 9 mode is activated, the camcorder records black bars at the top and bottom of the picture to produce the wide-screen effect. This is known as "letter box" recording. When played back on a standard size TV, black bars appear in the picture.

Do not use this recording mode unless you have a 16 x 9 TV.

New 16 x 9 TV Screen

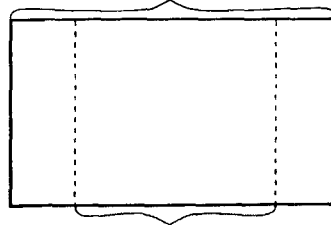

Standard Shape TV Screen



Recording Using 16X9



Normal Recording

To Record in 16 x 9 Format

1. Repeatedly press *DIGITAL ZOOM* to select **16X9**. The following display will appear in the viewfinder.
2. To turn off the **16X9** mode, repeatedly press the *DIGIT' ZOOM* button to return to the normal mode. No display will appear in the viewfinder.

16X9
Indicator

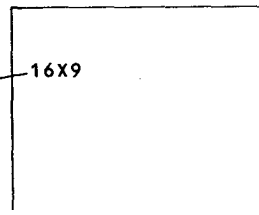

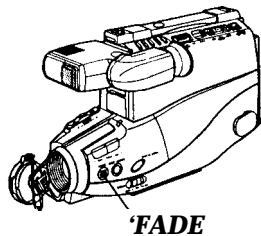

Fading In and Out of Scenes

You can add a professional touch to your recordings when you fade in and out of scenes. Both the picture and sound will gradually appear or disappear. The speed of the fade is controlled by the camcorder.



Select the Type of Fade

You can select white, wipe, or zoom fade.

- Select white fade to fade in and out from a white screen.  appears in the viewfinder.
- Select wipe fade to fade in and out from a black screen.  appears in the viewfinder.
- Select zoom fade to fade in and out while zooming.  appears in the viewfinder.

Repeatedly Press *FADE*

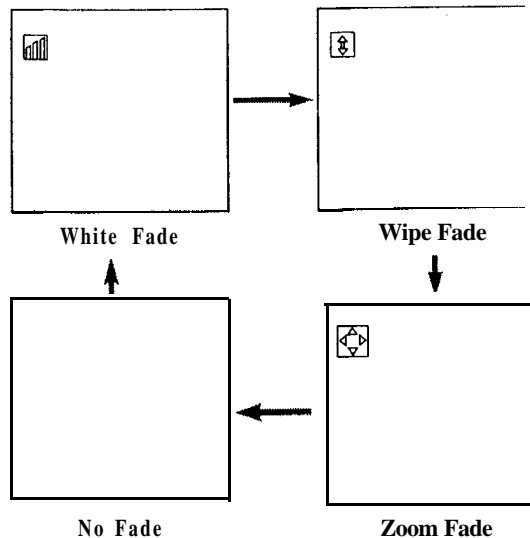

Fade In

1. Place the camcorder in record pause.
2. Repeatedly press *FADE* to select fade mode.
Note: The last fade mode used will appear the first time you press *FADE*.
3. Press *REC/PAUSE* to start recording. The picture and sound will gradually appear in place of the blank screen.

Fade Out

1. During recording, repeatedly press *FADE* to select the fade mode.
Note: The last fade mode used will appear the first time you press *FADE*.
2. Press *REC/PAUSE* to stop recording. The picture and sound will gradually disappear.

Time Counter with Memory Stop

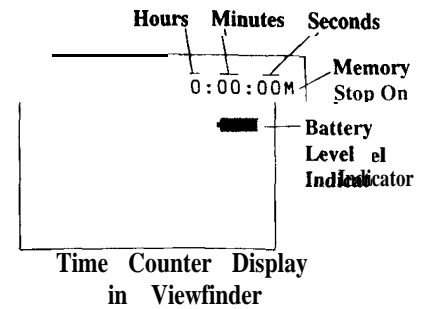
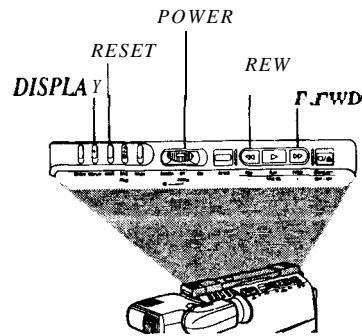

Using the Time Counter

The time counter is automatically displayed in the viewfinder and shows actual time elapsed when recording or playing back a tape. It helps you locate the end of recorded segments. For example, to locate the end of a 30-minute recording.

1. Press *RESET* to set counter to "0:00:00" at beginning of segment.
2. Press *F.FWD* to fast-forward the tape until time counter reads "0:30:00".

Memory Stop

The time counter's memory stop helps you locate a certain point on the tape. When memory stop is turned on, the tape will stop automatically during fast forward or rewind when the time counter reaches "0:00:00M".

Using Memory Stop:

1. Press *DISPLAY* to turn memory stop on. "M" appears after time counter when memory stop is turned on.
2. Locate the place on the tape you want to return to and press *RESET* to reset time counter to "0:00:00M".
3. Continue to record or play the tape.
When you want to return to the place you marked, press *REC/PAUSE* to stop recording, or press *STOP/EJECT* to stop playback.
4. Make sure *POWER* is in *VCR*. Then press *REW* (rewind). The tape will rewind until it reaches the time counter reading of "0:00:00M".

Notes: Press *DISPLAY* to turn memory-stop feature on or off.

Whenever memory stop is turned on, the camcorder will stop rewinding or fast forwarding when the counter reaches "0:00:00M". To continue rewinding or fast forwarding the tape, press *REW* (rewind) or *F.FWD* (fast forward) again.

The time counter is automatically reset to "0:00:00" whenever a cassette is inserted.

If you rewind a tape farther back than a counter reading of "0:00:00", a minus will appear in front of the time counter.

ProEdit® System



- Flying Erase Head
- Edit Search
- Audio Dub
- A/V (Audio and Video) Dub
- Titler

The camcorder incorporates a complete package of advanced editing features to make it easy and fun to edit your home videos like a professional. The major ProEdit® System features **are described here and on the following pages.**

Flying Erase Head



A separate erase head is mounted on the spinning headwheel (hence the term “flying”). The flying erase head allows you to make clean edits without “glitches” or “rainbow noise”.

Edit Search



The edit-search feature allows you to edit as you make your recording by using *F.FWD*, *REW*, and *PLAY* to precisely position the tape while the camcorder is in record pause.

- Press and hold *REW* (rewind) to visually search the recorded tape in reverse.
- Press and hold *F.FWD* (fast forward) to visually search forward on the recorded tape.
- Press and hold *PLAY* to view the recorded tape at **normal** speed.

When you release the button, the camcorder will return to record pause at that point on the tape.

Note: Noise bars may appear during search operation.

Audio Dubbing

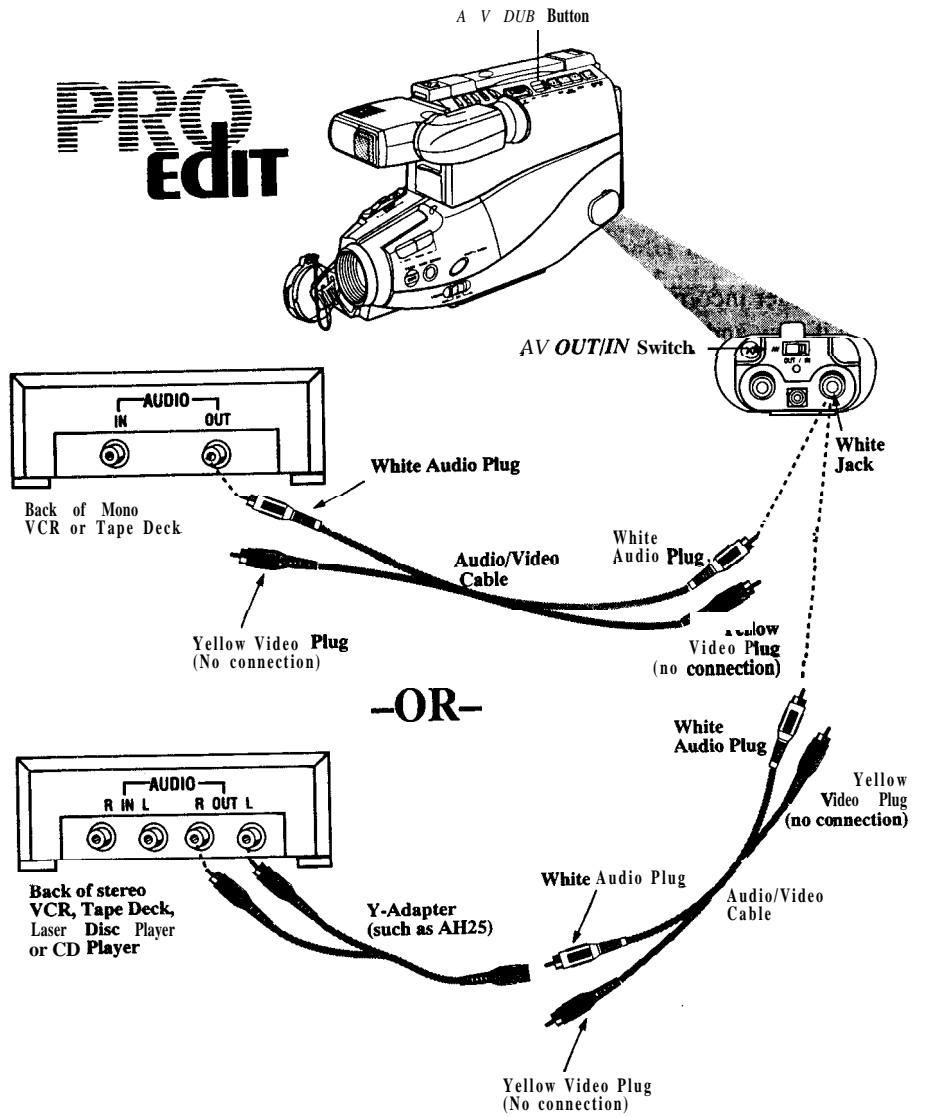

Note: If the audio source has separate left and right outputs, attach the audio plug to the one labeled *MONO*. If one is not labeled *MONO*, you may need a Y-adapter, as shown on page 4, to record audio from both the left and right channels.

Audio Dubbing (continued)

The audio dub feature lets you record new audio (sound) on a previously recorded tape without erasing the original video (picture). The previous audio is erased and replaced with the new audio.

The audio dub feature increases your editing flexibility. Video segments can first be assembled and then a single narration or music background can be added.

The new audio can be added two different ways.

- You can speak into the camcorder's built-in microphone.
- You can connect an external sound system to the white *AUDIO* jack on the camcorder.

To Audio Dub

1. Press and hold the small button on *POWER* while sliding it to *VCR*.
2. If you are recording from a source connected to the white *AUDIO* jack on the side of the camcorder, place *AV OUT/IN* switch to *IN*.
3. Insert the tape you want to audio dub and use *PLAY*, *F.FWD*, and *REW* to locate a point on the tape a few seconds before you want to begin dubbing.
4. Press *REC/PAUSE* exactly where you want to begin dubbing. This will place the camcorder in play pause.
5. Press and hold *AV DUB*, and then press *PLAY*. Release both buttons at the same time. *A. DUB II* will appear in the viewfinder when the camcorder is ready to begin audio dubbing.

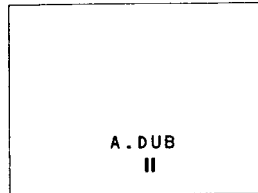

6. To begin dubbing, start the audio source and press *REC/PAUSE*. *II* will disappear from the viewfinder while you are dubbing.
7. Press *STOP/EJECT* when you are finished dubbing.

Notes: If you want to stop dubbing at a certain point on the tape, turn on memory stop, and set time counter to "*0:00:00M*" at the point where you want the dubbing to stop. The camcorder will stop dubbing automatically when it reaches "*0:00:00M*".

Remember, if you have dubbed from an external source - put the *AV OUT/IN* switch in *OUT* to record from the camcorder.

Audio and Video Dubbing

**PRO
Edit**

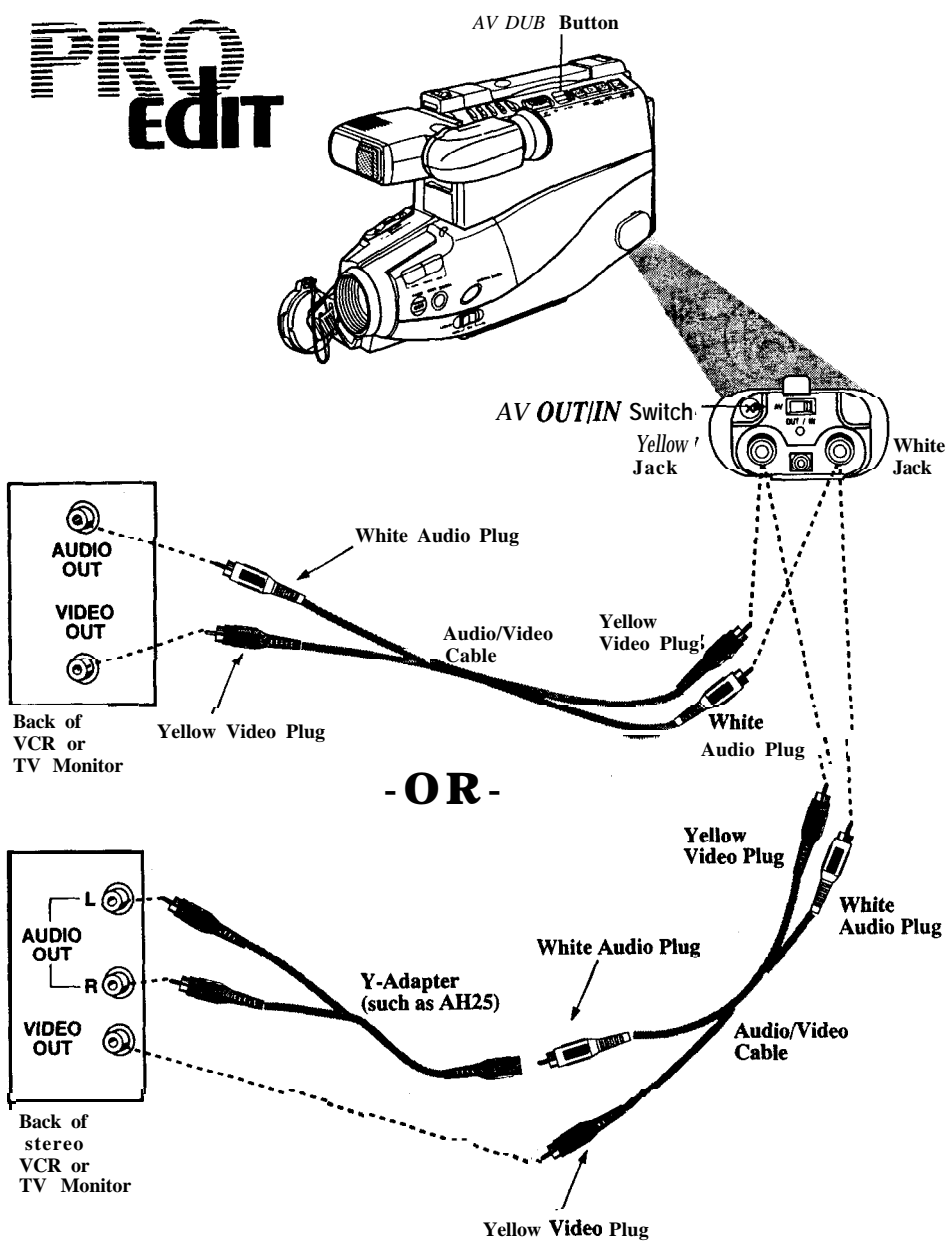

Audio and Video Dubbing (continued)

The audio and video dubbing feature lets you record new audio (sound) and video (picture) on a previously recorded tape in the camcorder.

The source for the dubbing is the camcorder's microphone and camera or a source connected to the *AUDIO/VIDEO* jacks on the side of the camcorder.

- To record from the camcorder's microphone and camera, no special connections are required.
- To record from an external video source (VCR, laser disc player, etc.), use the audio/video cable that came packed with the camcorder.

To Audio and Video Dub

1. Press and hold the small button on *POWER* while sliding it in *VCR*.
2. If you are recording from a source connected to the *AUDIO/VIDEO* jacks on the side of the camcorder, place the *AV OUT/IN* switch to *IN*.
3. Insert the tape you want to dub and use *PLAY*, *F.FWD*, and *REW* to locate a point on the tape a few seconds before you want to begin dubbing.
4. Press *REC/PAUSE* when the camcorder is playing exactly where you want to begin dubbing. This will place the camcorder in play pause.
5. Press and hold *AV DUB*, and then press *PLAY*. Release both buttons at the same time. *A DUB II* will appear in the viewfinder when the camcorder is ready to begin audio dubbing.
6. Press and hold *AV DUB*, and then press *PLAY* again. Release both buttons at the same time. *A/V DUB II* will appear in the viewfinder when the camcorder is ready to begin audio and video dubbing.

Note: If you are dubbing from a source connected to the *AV OUT/IN* jacks, be sure to start it playing.

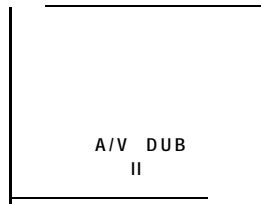

7. To begin dubbing, press *REC/PAUSE*. "II" will disappear from the viewfinder while you are dubbing.
8. Press *STOP/EJECT* when you are finished dubbing.

Notes: If you want to stop dubbing at a certain point on the tape, turn on memory stop and set the time counter to "*0:00:00M*" at the point where you want the dubbing to stop. The camcorder will stop dubbing automatically when it reaches "*0:00:00M*".

Remember, if you have dubbed from an external source — put the *AV OUT/IN* switch in *OUT* to record from the camcorder.

Titler



The camcorder's built-in titler can store two different titles in memory. Either title can be displayed and recorded at any time.

The built-in character register contains over 45 different characters for creating your titles. Each title can contain up to 32 characters on two lines.

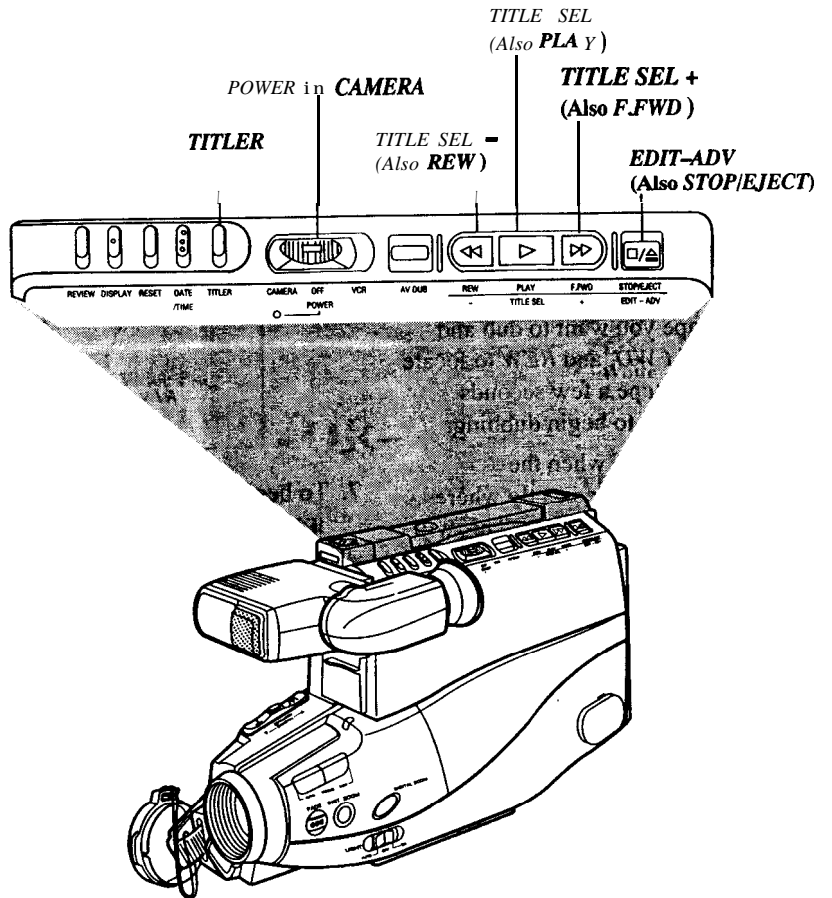

(continued on next page)

To Create a Title

1. Attach a power source to the camcorder, press and hold the small button on **POWER** while sliding it to **CAMERA**. **POWER** indicator will light.
2. Press **TITLER** to display titler graphics in the viewfinder. A flashing cursor will appear.
Note: Press **TITLE SEL** (select) to select the other title page. Each time you press **TITLE SEL**, it will switch between the two title pages.
3. Press **EDIT-V** (advance) to move the flashing cursor to the place you want to begin your title.
4. Select the first character for your title by pressing **TITLE SEL +** or **TITLE SEL -** until the character you want appears in the viewfinder.
Notes: You can scroll through the character register at a faster pace by pressing and holding **TITLE SEL +** or **TITLE SEL -**.

See the "Chart of Characters in Titler's Register" below for the characters available.

5. After you have selected the first character, press **EDIT-ADV** to move the flashing cursor where you want your next character to appear.
6. Repeat steps 4 and 5 until you have completed the title.
7. Press **TITLE SEL** if you wish to create another title on the other title page.
8. When you are finished, press **TITLER** to store the title and remove the title display from the viewfinder.

Important Note: Remember to remove the titler graphics from the viewfinder for normal recording.

To Correct an Error

1. Press **TITLER** to display the titler graphics in the viewfinder.
2. Press **EDIT-ADV** until the flashing cursor is placed over the character you wish to correct.

3. Press **TITLE SEL +** or **TITLE SEL -** until the correct character appears.
Notes: If you want to delete a title, replace each character with a blank space. If you want to delete a character, press **TITLE SEL +** or **TITLE SEL -** until the blank space appears.

Chart of Characters in Titler's Register																			
A	B	C	'	D	E	F	G	H	I	J	K	L	M	N	O	P	Q	R	S
T	U	V	W	X	Y	Z	0	1	2	3	4	5	6	7	8	9	?	'	
.	/	,	-	;	:	<	>	!	(BLANK)										

(continued on next page)

Recording Titles on a Tape in the Camcorder

To record a title on a tape in the camcorder, follow the steps below.

1. Attach a power source to the camcorder, slide **POWER** to **CAMERA**.
 2. Locate the place on the tape where you want to record the title.
Notes: If you record a title on a pre-recorded tape, the audio and video will be erased where the title is inserted. There will also be a three-to-four second pause of blank tape before the existing audio and video *return*.
Audio and video dubbing titles onto existing tapes will eliminate the pauses of blank tape. *Details are on pages 42-43.*
 3. Press **TITLER** to display the titler graphics in the viewfinder.
 4. Press **RECIPAUSE** to start recording the title.
 5. After you have recorded the title for the desired length of time, press **TITLER** to remove titler graphics from the viewfinder. The camcorder will now record as normal. If you do not want to continue recording, press **RECIPAUSE**.
- Important Note:** Remember to remove the titler graphics from the viewfinder for normal recording.

Recording Titles While Copying a Tape from Camcorder to Another VCR

This method of adding titles lets you keep the original tape as it is, and add titles to the copy you are making on another VCR. Connect your camcorder to a VCR *as shown on pages 52-53*.

1. Attach a power source to the camcorder.
 2. Place the tape you want to copy in the camcorder and place **POWER** in **VCR**.
 3. Press **TITLER** to display the title you want to record. If you want to record the other title page, press **TITLE SEL**. The camcorder will recall the last title page displayed the next time you press **TITLER**.
 4. Press **TITLER** to remove titler graphics from the viewfinder.
 5. Place a blank tape in the VCR, and place the VCR in record pause.
 6. Start copying the tape from the camcorder to the VCR. *Details for copying a tape are on pages 52-53.*
 7. When you see the place on the tape you want to insert the title, press **TITLER**.
Note: Make sure counter memory is turned off. Press **DISPLAY** to **turn** it off.
 8. After you have recorded the title for the desired time, press **TITLER** to stop recording the title.
 9. Stop the camcorder and VCR when you are finished copying the tape.
- Important Note:** Remember to remove the **titler** graphics from the viewfinder for normal playback.

Make a **recording** of your home and contents to store in a safe place in case of **fire or theft**.

Practice **recording** under a variety of lighting conditions. This will help you **respond quickly** whenever you see a scene you want to record.

Fading in and out of scenes may make your videos appear more professional.

When using **manual focus**, check the focus before recording. Zoom in on the subject and **adjust the focus** until you see a clear image in the viewfinder. Then zoom back to where you want to record. If the subject-to-camcorder distance does not change, the subject will remain in sharp focus over the entire zoom range.

Do not move the camcorder rapidly from side-to-side while recording. A steady, gradual "pan" avoids blurring and "jitter".

Use the viewfinder to make sure the camcorder is level while recording or your scenes will appear "tilted".

Make sure indoor scenes are well-lit to improve picture quality and color reproduction.

Do not bump or tap the camcorder's microphone while recording because this sound will be recorded.

Be aware of video and audio backgrounds. Background details barely noticed while you are taping may show up as visual "clutter" on your recording. Background noises (especially TV sets, radios, household appliances, traffic sounds, etc.) can detract from the sound you want to record.

Avoid long "still" shots of landmarks and scenic attractions. Recordings are more interesting if they include people and details. "Local color" will give travel videos lasting appeal. Consider recording a familiar or landmark scene from an unfamiliar vantage point for added interest. Remember to check the lighting before starting to record.

Try to avoid taping backlit subjects indoors. Bright light behind your subject may cause the subject to appear too dark.

Include close-up shots of individuals when taping family outings or group functions.

For a different perspective, try kneeling down (or laying) on the floor when recording children or pets.

Recording on the Camcorder from a VCR or TV Monitor

To record on a tape in your camcorder from a VCR or TV monitor with *AUDIO OUT* and *VIDEO OUT* jacks, you will need the supplied audio/video cable.

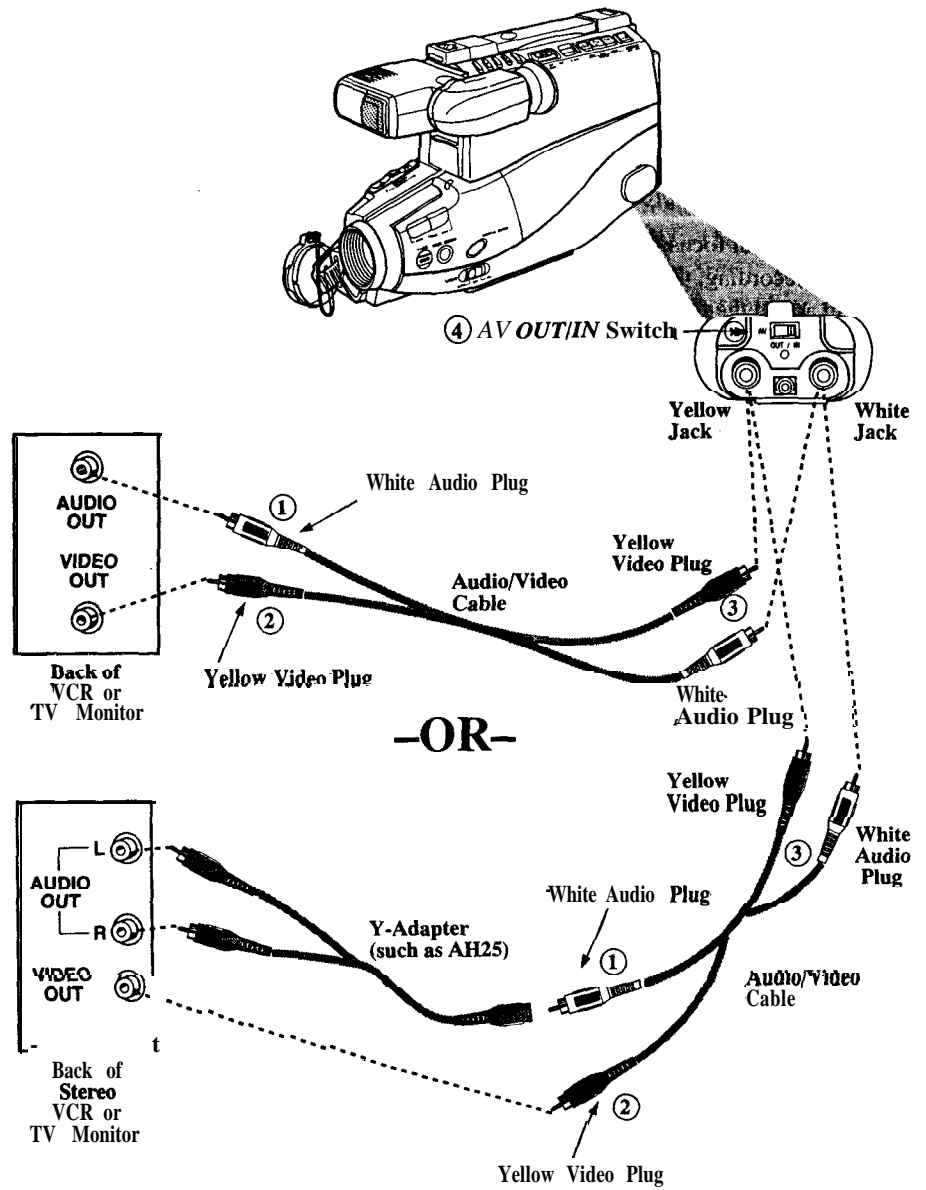

Installation

- ① Attach the white plug on one end of the audio/video cable to the *AUDIO OUT* jack on the VCR (or TV monitor).
Note: If your VCR or TV monitor has stereo left and right *AUDIO OUT* jacks, attach the plug to the one labeled *MONO*. If one of the audio jacks is not labeled *MONO*, you may need a Y-adaptor, such as *AH25* shown on page 4, to hear both channels.
- ② Attach the yellow plug on the same end to the *VIDEO OUT* jack on the VCR (or TV monitor).
- ③ Attach the yellow plug on the other end of the audio/video cable to the yellow *VIDEO* jack and the white plug to the white *AUDIO* jack on the side of the camcorder.
- ④ Place the *AV OUT/IN* switch to IN.

Recording Operation and How to Copy Tapes on the Camcorder

1. A. **Camcorder connected directly to TV monitor:** Turn on the TV and tune it to the channel you want to record.
B. **Camcorder connected to a VCR that is already connected to a TV:** Turn on the VCR and select the channel you want to record (or place the cassette you want to copy in the VCR). If you are copying a tape, press *PLAY* on the VCR when you are ready to start copying.
Note: If you want to see what is being recorded, turn on the TV and tune it to the channel that you normally use to see the signal from the VCR.
2. Press and hold the small button on the camcorder's *POWER* switch while sliding it to *CAMERA*.
3. Insert a cassette in the camcorder with the safety tab intact.
4. Press *REC/PAUSE* to start the camcorder recording.
Note: If you are copying a tape, start the VCR playing the tape.
5. Press *REC/PAUSE* on the camcorder when you are finished.
Note: Make sure counter memory is turned off. Press _____ to turn it off.

Caution: The unauthorized recording of television programs and other materials may infringe the rights of others.

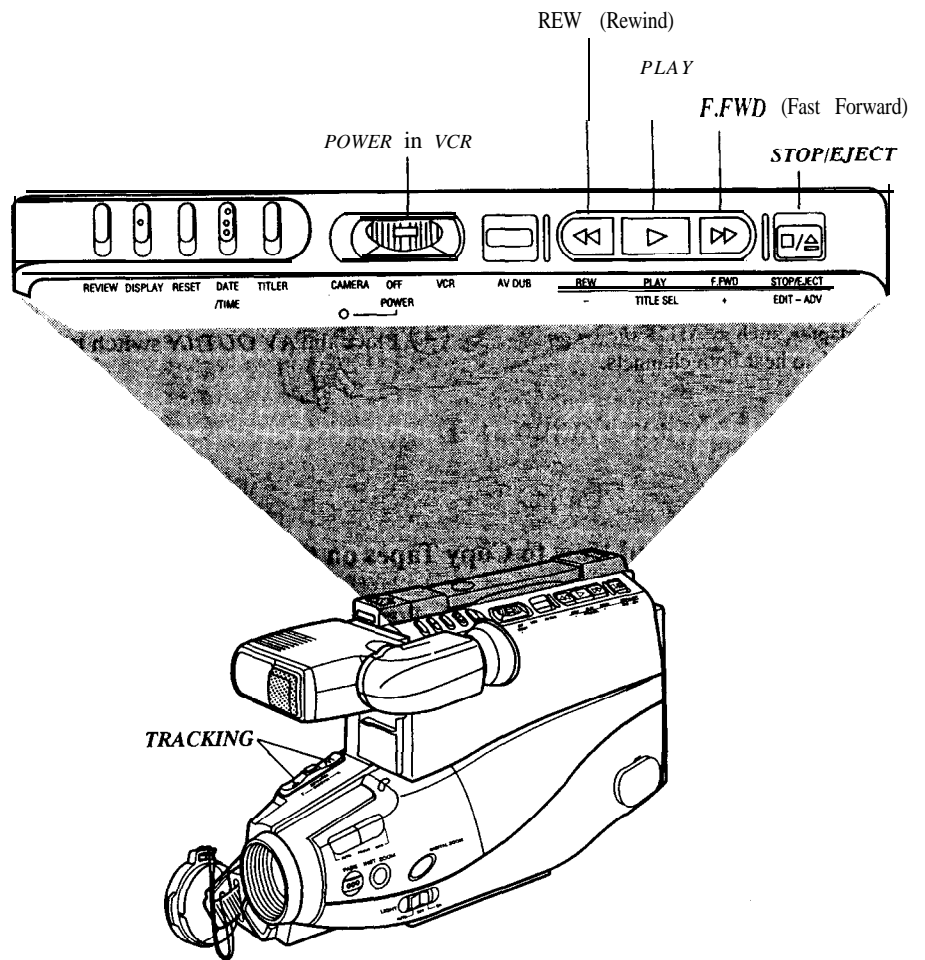

Viewfinder Playback

1. Attach a power supply to the camcorder.
2. Press and hold the small button on **POWER** while sliding it to **VCR**.
3. Press **STOP/EJECT** and insert the cassette you want to play back.
 Note: The camcorder can only play back tapes recorded at SP speed.
4. Press **PLAY** to begin playback. Adjust **TRACKING** if necessary.
5. Press **STOP/EJECT** when you are finished.

Handwritten signature or mark

Playback Features

Stop-Action Pause

During playback, you can view one frame of the tape.

- Press *REC/PAUSE* to stop the action.
- Press *REC/PAUSE* again to return to normal playback.

Caution: Pause is designed for momentary interruptions and should not be used for an extended period of time. If the camcorder remains in pause for more than five minutes, it will automatically remove the tape from the spinning heads to prevent excessive tape wear.

Picture Search

During playback you can visually search the tape at a higher speed in forward or reverse.

- Press and hold *F.FWD* to search the tape forward.
- Press and hold *REW* to search the tape in reverse.
- Release the button to return to normal playback.

Tracking

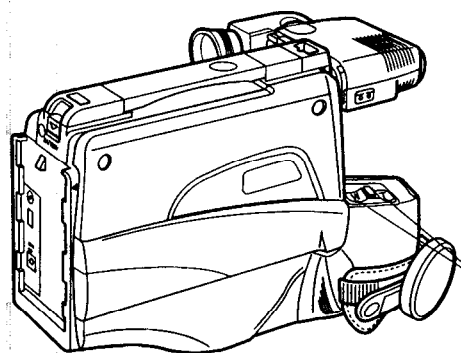

TRACKING
(Also Power Zoom)

When you play a tape not recorded on your camcorder, streaks may appear. To remove the streaks, press either *TRACKING* button to move the streaks up or down and out of the picture.

Press either *TRACKING* button during stop-action (play-pause) to reduce picture "jitter" (picture bouncing up or down).

Remove the cassette to reset the camcorder's tracking to its preset center. The *TRACKING* buttons only affect tape playback. They have no effect during recording.

Playback on a TV or VCR with AUDIO and VIDEO IN Jacks

To connect your camcorder to a TV monitor (or VCR) with AUDIO IN and VIDEO IN jacks, you will need the audio/video cable supplied with the camcorder. If your TV is already connected to a VCR, you can attach the camcorder to the VCR and watch what the camcorder is recording or playing on the TV.

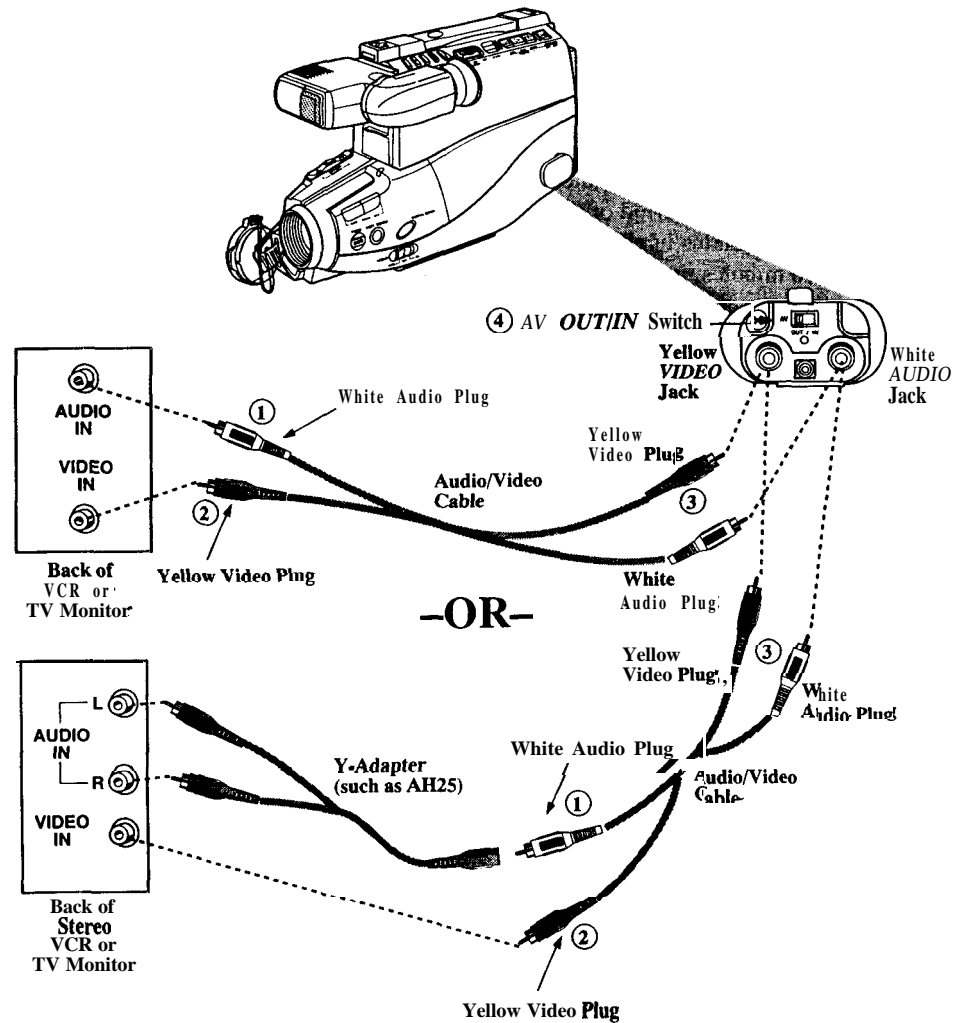

Caution: The unauthorized recording of television programs and other materials may infringe the rights of others.

Playback on a TV (continued)

- ① Attach the white plug on one end of the audio/video cable to the **AUDIO IN** jack on the TV or VCR.
Note: If your TV (or VCR) has stereo left and right **AUDIO IN** jacks, attach the plug to the one labeled **MONO**. If one of the jacks is not labeled **MONO**, you may need a Y-adaptor, such as AH25 shown on page 4, to hear both channels.
- ② Attach the yellow plug on the same end of the audio/video cable to the **VIDEO IN** jack on the TV or VCR.
- ③ Attach the yellow plug on the other end of the audio/video cable to the yellow **VIDEO** jack and the white plug to the white **AUDIO** jack on the side of the camcorder.
- ④ Place the **AV OUT/IN** switch to **OUT**.

Playback Operation and How to Copy Tapes on a VCR

1. A. Camcorder connected directly to TV monitor: Turn on the TV and tune it to its video input channel.
B. Camcorder connected to VCR that is already connected to TV: Turn on VCR and place it in the "line" or "camera" mode. (If your VCR does not have a "line" or "camera" mode, consult the VCR owner's manual.) Operate the TV as you normally do to see the signal coming from the VCR.
2. Press and hold the small button on the camcorder's **POWER** switch while sliding it to **VCR**. Insert the cassette you want to playback (or copy).
Note: The camcorder can only playback tapes recorded at the SP speed.
3. Press **PLAY** on the camcorder. To copy what the camcorder is playing, place a blank cassette in the VCR and start the VCR recording. Adjust the tracking on the camcorder if necessary. *Details are on page 51.*
. During playback, use the playback features described on page 51.
4. Press **STOP/EJECT** when you are finished.

Watching What the Camcorder is Seeing or Recording on the TV

1. A. Camcorder connected directly to TV: Turn on the TV, and tune it to its video input channel.
B. Camcorder connected to VCR that is already connected to TV: Turn on VCR and place it in the "line" or "camera" mode. (If your VCR does not have a "line" or "camera" mode, consult the VCR owner's manual.) Operate the TV as you normally do to see the signal coming from the VCR.
2. Press and hold the small button on the camcorder's **POWER** switch while sliding it to **CAMERA**. Insert the cassette you want to record on.
Note: When the camcorder is used as a camera, turn the TV's volume down to prevent a high-pitched squeal caused by feedback.
3. Press the camcorder's **REC/PAUSE** button to begin recording. You can watch what the camcorder is seeing or recording on the TV screen.

Playback on a TV Without Audio and Video Inputs

To connect your camcorder to a TV without audio and video input jacks, you will need an optional RF output adapter and an optional coaxial RF cable.

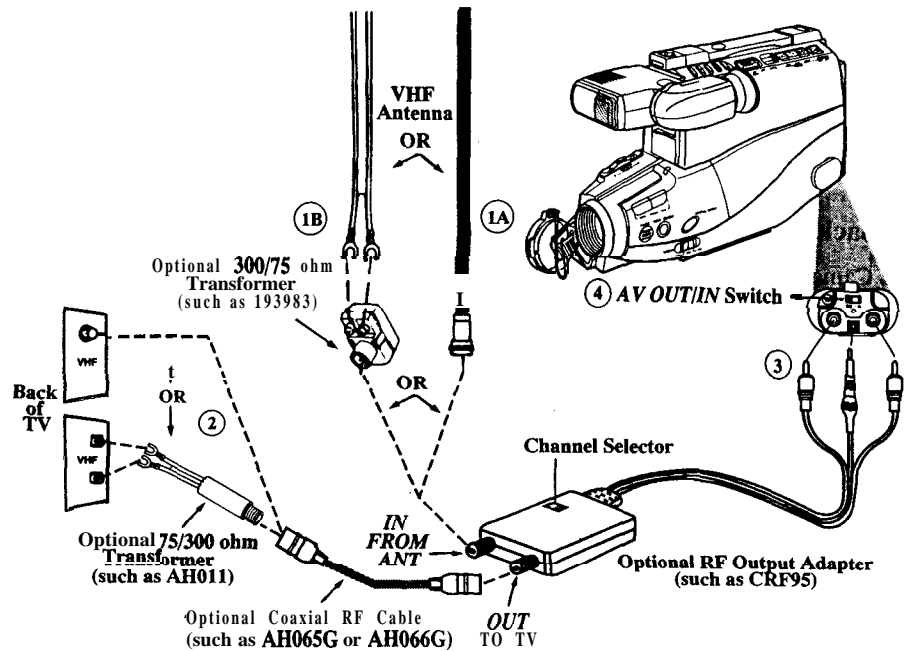

1 Disconnect the VHF antenna from your TV. If you are going to leave the RF adapter connected to the TV, connect the antenna to the RF output adapter.

A. If antenna is round 75-ohm cable, connect it to *IN FROM ANT* connector on RF output adapter.

B. If antenna is flat twin-lead, connect flat-lead connectors to screw terminals on optional 300-75 ohm transformer. Then connect transformer to *IN FROM ANT* connector on RF output adapter.

2 Attach one end of coaxial RF cable to *OUT TO TV* connector on RF adapter, and attach other end of the cable to VHF input on TV *as shown*.

Note: If TV has screw terminals, you may need an optional 75-to-300 ohm transformer, such as AH011.

3 Attach RF output adapter's yellow plug to the *VIDEO* jack, small plug to the RF *DC OUT* jack, and white plug to the *AUDIO* jack on the side of the camcorder.

4 Place the *AV OUT/IN* switch to *OUT*.

Playback on a TV Without Audio and Video Inputs (continued)

Playback Operation

1. Set the channel selector switch on the RF output adapter to *CH3* or *CH4*.
2. Turn on the TV and tune it to the same channel (3 or 4) you selected with the channel selector switch on the RF output adapter.
3. Press and hold the small button on the camcorder's *POV&R* switch while sliding it to *VCR*.
4. Insert the cassette you want to play back into the camcorder.
Note: The camcorder can only play back tapes recorded at the *SP* speed.
5. Press *PLAY* on the camcorder. Adjust tracking on the camcorder, if necessary. *Details are on page 51.*
 - During playback, use the playback features described on page 51.
6. Press *STOP/EJECT* on the camcorder when you are finished playing back the tape.

Watch What the Camcorder is Seeing or Recording on the TV

1. Turn on the TV and tune it to channel 3 or 4 (the same channel you selected with the channel selector switch on the RF output adapter).
2. Press and hold the small button on the camcorder's *POWER* switch while sliding it to *CAMERA*. Insert the cassette you want to record on.
3. Press the camcorder's *REC/PAUSE* button to begin recording. You can watch what the camcorder is seeing or recording on the TV screen.
Note: When the camcorder is used as a camera, turn the TV's volume down to prevent a high-pitched squeal caused by feedback.

Normal TV Viewing

For normal TV viewing, you can leave the RF output adapter hooked up to the TV. Just disconnect the adapter's plug

from the camcorder or turn the camcorder's power off.

Note to Cable Installer: This reminder is provided to call your attention to Article 820-40 of the National Electrical Code (Section 54 of Canadian Electrical Code, Part I), that provides guidelines for proper grounding and, in particular, specifies that the cable ground shall be connected to the grounding system of the building as close to the point of cable entry as practical.

Color Enhancement Light

The color enhancement light helps create brighter, sharper pictures.

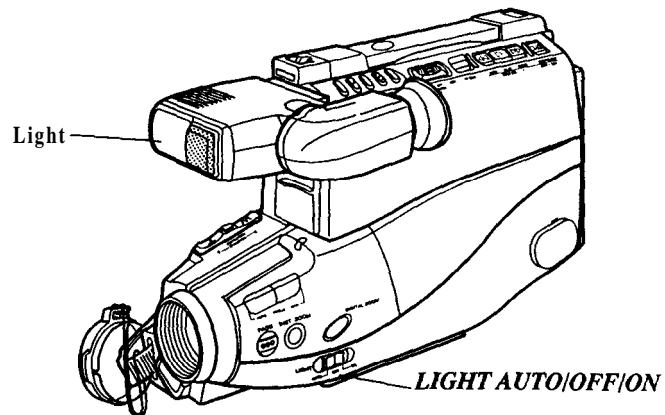

To Use the Color Enhancement Light

1. Attach the rechargeable battery or AC adapter/charger to power the camcorder.
2. Press and hold the small button on *POWER* and place it in *CAMERA*.
3. Select a position for the *LIGHT AUTO/OFF/ON* switch.
 - Place in *AUTO* to have the light automatically turn on when the camcorder is aimed at a dark object and turn off when aimed at a bright object. There must be a cassette in the camcorder for the *AUTO* feature to operate.
 - Place in *ON* to have the light turn on whenever *POWER* is in *CAMERA*.
 - Place in *OFF* to turn off the light.

If the camcorder is left in record pause for more than five minutes, the power and light automatically turn off. Press *REC/PAUSE* to turn camcorder back on.

Notes: Turn on the light only when you need it. The power consumption of the light is approximately two-thirds that of the camcorder. When the light is on, the operation time of the rechargeable battery is reduced.

Avoid bumping or shaking the light when in use. The light's bulb is sensitive when hot and may burn out.

Do not allow water to drop on the light when in operation.

Dangers: During operation and after using the light, the front surface and bulb of the light will be very hot. To avoid burns, do not touch them.

To prevent overheating, do not block or cover the ventilation holes on the color enhancement light.

Never use the color enhancement light in the vicinity of explosives or highly flammable materials.

Removing and Replacing the Front Case of the Light

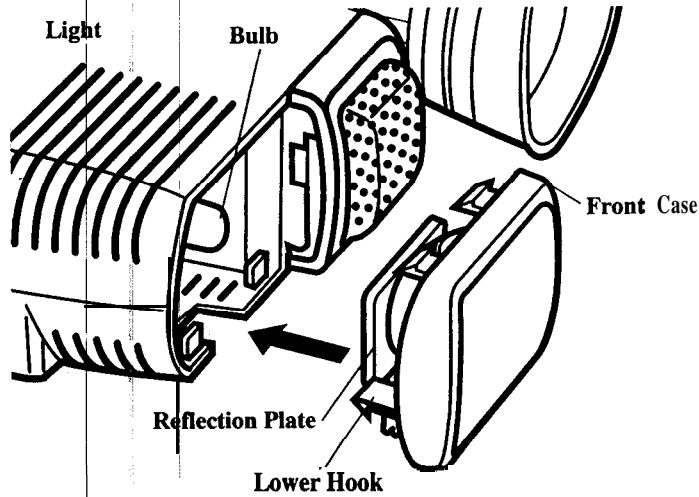

To Remove and Replace Light Case

1. To remove front case, press and hold the lower hook while removing it.
2. To replace the front case, pass the bulb through the hole of the reflection plate, and attach the lower hook to the light.
3. Press front of case to light.

Notes: Do not touch the bulb with your fingers. It may shorten its service life.

Make sure the front case of the light is properly attached after removing it or replacing a bulb.

When replacing the bulb, only use #221 11 1 to reduce the risk of fire and other hazards.

See the installation instructions packed with the replacement bulb when replacing the bulb.

Caution: Use **only** bulb x221 111 when replacing the bulb to **reduce the** risk of fire or other hazards,

Attaching the Shoulder Strap

The shoulder strap is designed to let you carry the camcorder from your shoulder and -when you are ready to shoot — bring the camcorder to shooting position in one quick movement.

Cautions: When carrying the camcorder with the shoulder strap, place the viewfinder in **its** original position. This **helps prevent** possible damage to the viewfinder **from** bumping against **your body** as you move.

Make sure **the shoulder strap is firmly attached before using it to carry your camcorder.**

To Attach the Shoulder Strap

1. Unfasten one end of the shoulder strap from the buckle. Make sure you leave the buckle on the strap.



2. Thread one end of the shoulder strap through one of the shoulder strap rings as shown below in diagrams A and B.

Diagram A

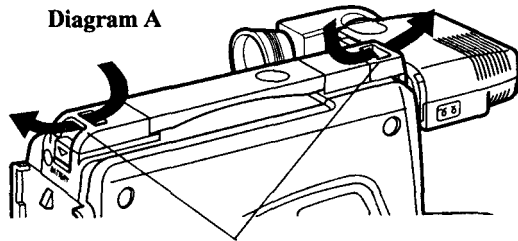
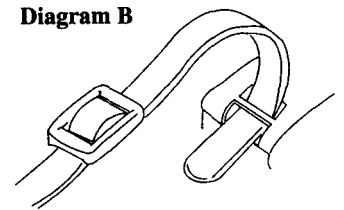
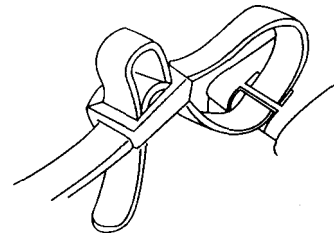

Diagram B



Shoulder Strap Rings

3. Thread the strap back into the buckle as shown below. Pull on the strap and make sure it is fastened correctly and tightly before using it to support your camcorder.



4. Repeat steps 1-3 to attach the other end of the shoulder strap.

Camcorder Traveling and Cassette Tips

Traveling Tips

Write down your camcorder's serial number and keep it separate from the camcorder when traveling. If your camcorder is lost or stolen, you will be able to identify it.

Make sure you have any plug adapters you need before taking your camcorder to other countries. Consult your dealer.

Use extra care to avoid damage to your camcorder and accessories when operating them at a beach or pool. Spray, sand, and dust should be avoided. If your lens has been exposed to the elements, clean it only with proper lens cleaning supplies.

Carry your camcorder in a carrying case when traveling. See page 2 for a specially designed case. An ordinary suitcase or carry bag does not offer the protection your camcorder needs. Treat your camcorder as carry-on luggage to protect it from rough handling.

Cassette Tips

Do not use a cassette if it has been damaged or exposed to moisture. The tape may jam or damage your camcorder.

When you are finished recording, break off the safety tab on the cassette to prevent accidental erasure.

Label your cassettes before storing them.

Store your cassettes vertically in their protective cases at normal room temperature.

Do not leave your camcorder or cassettes in a car or outdoors for an extended period. Excessive heat or cold may damage them.

Care and Maintenance

Keep dust and grit from entering the camcorder's cassette door. Dust and grit are abrasive and cause excessive wear to both the camcorder's recording and playback heads and cassettes.

Before handling your camcorder, make sure your hands and face are free from any chemical products such as suntan lotion, as it may damage the finish.

Do not touch the lens with your fingers! The oil from your skin may damage the lens. To clean the lens, blow it with a blower brush, and gently wipe it with a lens-cleaning tissue and commercially prepared cleaning solution designed for use on camera lens. Improper cleaning may scratch the lens.

To clean the camcorder's exterior, remove any power source. Gently wipe the camcorder with a clean soft cloth. **Use of strong or abrasive cleaning products, such as those containing alcohol or benzine, may damage the camcorder.**

The camcorder can be damaged by improper storage or handling. **Do not** subject the camcorder to swinging, shaking, or dropping.

Do not store the camcorder in temperatures below -22°F (-30°C) or above 149°F (65°C).

Do not aim your camcorder at the sun or other bright objects or leave your camcorder in direct sunlight. Doing so could permanently damage the camcorder's internal parts.

Avoid operating your camcorder after moving it from a cold location to a warm location. Moisture may cause the tape to stick to the headwheel and damage the headwheel or tape. Give the camcorder 2 to 3 hours to reach a stable temperature before inserting a cassette.

Do not operate or leave your camcorder in extremely humid environments.

Do not operate the camcorder for extended periods in temperatures below 40°F (4°C) or above 95°F (35°C).

Do not expose the camcorder or adapter/charger to rain or moisture. If either component becomes wet, turn **off** the power and take the unit to an Authorized RCA Camcorder Servicer.

Retain the original carton for future storage or shipping purposes.

When the camcorder is not in use, always remove the cassette and AC adapter/charger or battery.

Always replace the lens cap on the lens when the camcorder is not in use.

Specifications

General

Power requirement: 9.6VDC

Power consumption: 7 watts (normal)

Weight: 4.4 lbs. (2 kg)

Dimensions:

4-1/2"(W) x 8-1/8"(H) x 12-1/4"(D)
(111 x 205 x 311mm)

Video Recorder Section

Format: VHS

Record/Playback System:

Two video record/playback heads

One flying erase head

Headwheel Cylinder Diameter: 62 mm

Video Signal: EIA Standard NTSC
Color

Camera Section

Scanning: 525 Lines/60 Fields/30
Frames

Image Sensor: 1/3" high/resolution,
solid state CCD Imager

Tripod Mount: One 1/4" x 20 threaded
hole

Lens: f1.8

12: 1 (5-60mm)

Diameter: 46 mm

Information to User

This equipment has been tested and found to comply with the limits for a Class B digital device, pursuant to Part 15 of the FCC Rules. These limits are designed to provide reasonable protection against harmful interference in a residential installation. This equipment generates, uses, and can radiate radio frequency energy and, if not installed and used in accordance with the instructions, may cause harmful interference to radio communications. However, there is no guarantee that interference will not occur in a particular installation. If this equipment does cause harmful interference to radio or television reception, which can be determined by turning the equipment off and on, the user is encouraged to try to correct the interference by one or more of the following measures:

- Reorient or relocate the receiving antenna.
- Increase the separation between the equipment and receiver.
- Connect the equipment into an outlet on a circuit different from that to which the receiver is connected.

- Consult the dealer or an experienced radio/TV technician for help.

Alterations or modifications carried out without appropriate authorization may invalidate the user's FCC right to operate the equipment.

This digital apparatus does not exceed the Class B limits for radio noise emissions from digital apparatus as set out in the interference-causing equipment standard entitled "Digital Apparatus", ICES-003 of the Department of Communications.

Cet appareil numérique respecte les limites de bruits radioélectriques applicables aux appareils numériques de Classe B prescrites dans la norme sur le matériel brouilleur: "Appareils Numériques", NMB-003 édictée par le ministre des Communications.

Limited Warranty

What your warranty covers:

- Any defect in material or workmanship.

For how long after your purchase:

- Ninety days for labor charges.
- One year for parts.
The warranty period for rental units begins with the first rental.

What we will do:

- Pay any Authorized RCA Camcorder Servicenter the labor charges to repair your camcorder.
- Pay any Authorized RCA Camcorder Servicenter for the new or, at our option, refurbished replacement parts required to repair your camcorder.

How you get service:

- Check **with** your RCA Camcorder Dealer or call 1-800-336-1900 for the Authorized RCA Camcorder Servicenter nearest you. State that you have an RCA camcorder.

If an Authorized RCA Camcorder Servicenter is conveniently near you:

- Take your camcorder to the Authorized RCA Camcorder Servicenter of your choice.
- Show the service center representative your sales receipt or other evidence of purchase date.
- Pick up your camcorder when repairs are completed.

If an Authorized RCA Camcorder Servicenter is not located conveniently near you:

- Pack the camcorder so that it will not be damaged during shipping.
(We recommend **using the original carton** and packing materials.) Include any cables and other accessories originally furnished with the camcorder.

- Include in the camcorder carton (1) a **copy** of your sales receipt or other evidence of purchase date, (2) your name and address, and (3) a brief description of the problem.
- Ship the camcorder to an Authorized RCA Camcorder Servicenter.
- Pay any charges billed to you by the Servicenter for service not covered by the warranty.

What your warranty **does not** cover:

- Customer instruction. (Your owner's manual clearly describes how to install, adjust, and operate your camcorder. Any additional information should be obtained from your dealer.)
- Installation and related adjustments.
- Cleaning of video/audio heads.
- Damage from misuse or neglect.
- Battery for clock or other features.
- A camcorder that has been modified or incorporated into other products or is used for institutional or other commercial purposes.
- A camcorder purchased or serviced outside the USA.

Product Registration:

- Please complete and mail the **product registration card** packed with your camcorder. It will make it easier to contact you should it ever be necessary. The return of the card is not required for warranty coverage.

How state law relates to this warranty:

- This warranty gives you specific legal rights and you also may have other rights that vary from state to state.

If you purchased your camcorder outside the United States:

- This warranty does not apply. See your dealer for details.

Trouble Checks

Troubles sometimes are caused by simple "faults" that you can easily correct without the help of a service technician by first checking a few basic remedies.

Before you call or take your camcorder to an Authorized RCA Camcorder Servicenter, look below for the type of trouble you are experiencing. Then perform the simple Checks and adjustments listed for that trouble.

Trouble	Checks and Adjustments
No Power (POWER Indicator Will Not Come On)	<ul style="list-style-type: none"> . If using the rechargeable battery, it may need recharging. . If using the AC adapter/charger, make sure it is plugged into a working AC outlet.
Will Not Record or Play Back	<ul style="list-style-type: none"> . Make sure there is a cassette in the camcorder. . Try ejecting and re-inserting the cassette. . The cassette tape is broken — try another cassette. . You have reached the end of the cassette — try rewinding it. . Moisture condensation may cause the tape to stick to the headwheel and damage the headwheel or tape. Give the camcorder 2 to 3 hours to reach a stable temperature before re-inserting a cassette.
Will Not Play Back	<ul style="list-style-type: none"> . POWER switch must be in VCR.
Will Not Record	<ul style="list-style-type: none"> . Safety tab has been removed from cassette. <i>See page 22.</i> . POWER switch must be in CAMERA. . AV OUT/IN switch must be in OUT to record from the camcorder.
No Picture in Viewfinder	<ul style="list-style-type: none"> . Make sure the lens cap has been removed.
Tape Does Not Rewind or Fast Forward	<ul style="list-style-type: none"> . Make sure titler graphics do not appear in viewfinder. Press TITLER to remove them.

(continued on next page)

Trouble Checks (continued)

Trouble	Checks and Adjustments
Tape Stops During Rewind or Fast Forward	<ul style="list-style-type: none"> The time counter's memory-stop feature may be turned on. When an "M" appears behind the time-counter display, the camcorder will stop rewinding or fast-forwarding when the counter reads "0:00:00M". Press the <i>REW</i> (rewind) or <i>F.FWD</i> (fast forward) button again to continue, or press <i>DISPLAY</i> to turn off memory stop.
Camcorder Remains in Play Pause	<ul style="list-style-type: none"> Press <i>REC/PAUSE</i> to return to normal playback.
Poor Picture Quality During Recording	<ul style="list-style-type: none"> There is insufficient light. Add more light. Make sure <i>FOCUS</i> does not appear in the viewfinder. Press both <i>FOCUS</i> buttons together to turn on auto focus. <i>Details are on page 32.</i> Use the color enhancement light to add more light. <i>Details are on pages 56-57.</i>
Viewfinder Displays are out of Focus	<ul style="list-style-type: none"> Try adjusting the eyepiece focus control. <i>Details are on page 26.</i>
Poor Auto-Focus Operation	<ul style="list-style-type: none"> Make sure <i>FOCUS</i> does not appear in the viewfinder. Press both <i>FOCUS</i> buttons together to turn on auto focus. <i>Details are on page 32.</i> Subject may be too dark or behind glass. Auto-focus system may not work under these conditions. Focus manually. <i>Details are on pages 32-33.</i> Lens may be smudged and image appears unfocused. Viewfinder eyepiece focus may be adjusted incorrectly. <i>Details are on pages 26-27.</i> Camcorder is in macro-focus mode. Press and hold the power zoom button "<i>T</i>" to release macro-focus.
Poor Picture Quality During Playback	<ul style="list-style-type: none"> Tape was recorded on a different camcorder or VCR. If the picture contains black-and-white streaks, press one of the <i>TRACKING</i> buttons to correct. Camcorder only has one speed (SP). If the tape was recorded on a different VCR at a different speed, it cannot be played back in this camcorder.

Trouble Checks (continued)

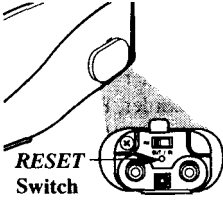
Trouble	Checks and Adjustments
Recorded Audio is Too Low	<ul style="list-style-type: none"> Subject may have been too far from the camcorder.
AE Shutter-Speed or INDEX Indicator Does Not Appear in Viewfinder	<ul style="list-style-type: none"> POWER switch must be in CAMERA.
Date and Time (or Date) Were Recorded on the Tape	<ul style="list-style-type: none"> Date and time (or date) will be recorded on the tape whenever they appear in the viewfinder. Press DATE/TIME to remove them from the viewfinder when recording.
Picture Appears Grainy	<ul style="list-style-type: none"> Make sure digital zooming mode is not selected. Details on pages 34-35.
Picture Appears with Black Bars	<ul style="list-style-type: none"> Make sure 16X9 mode is not selected. Details are on page 36.
Date and Time Appear Incorrect	<ul style="list-style-type: none"> Make sure the date and time have been set. Details on page 30. The camcorder's internal clock battery may need recharging. Details on page 31.
Camcorder Does Not Power Up and/or Function Buttons Are Inoperative.	<ul style="list-style-type: none"> Remove the power source. After one minute, push the RESET switch gently using a non-metallic pointed item, such as a toothpick, until you feel a click. Since this erases the date, time, and other customer preferred features, they will need to be reset. 

Index

16x9 Indicator	28,36	Clock Battery, Charging	31
16x9 Mode	36	Contents	1
A.DUB Indicator..	28,41,43	Copying Tapes..	48-49,52-53
<i>AIV DUB</i> Indicator..	28,43	Correcting the Date and Time	30
Accessories, Included..	10	Date and Time Displays	28-29,30-31
Accessories, Optional	2-9	Date and Time Recording	31
Accessory Lens, Attaching	5	<i>DATE/TIME</i> Button	14,30-31
Accessory Order Form..	7-9	DC IN 9.6V Jack..	11,15,16
Adapter/Charger, Safety Instructions	iii	Design Specifications	61
Adapter/Charger, Using	11,16	<i>DIGITAL ZOOM</i> Button..	14,28,35,36
Adjustments and Checks..	63-65	<i>DISPLAY</i> Button	14,29,38
AE (Auto Exposure) Display..	24,28	Dubbing	40-43
Attaching the Battery	11,18	Edit Search	39
Attaching the Shoulder Strap..	58	EDIT—ADV Button	14,44-45
Audio Dubbing	40-41	Electronic Indexing	25
AUDIO/VIDEO		Erase Protection	22
Jacks..	14,40-41,42-43,48-49,52-53,54	Eyepiece Focus Control	12,14,26
Audio/Video Dubbing	42-43	<i>F.FWD</i> Button..	14,24,38,39,41,43,51
AUTO Date Display..	28-29,31	<i>FADE</i> Button..	14,28,37
Auto Focus	32	Fade Indicators..	28,37
AV (Audio/Video) OUT/IN		Fading	37
Switch	14,40-41,42-43,48-49,52-53,54	Fast Forward Indicator (▶▶)	28
AVDUB Button..	14,41,43	First-Time Operation	10-15
BATTERY Eject Lever..	15,18	Flying Erase Head..	39
Battery Care and Storage	19	FOCUS AUTO/MAN Buttons..	14,28,32,33
Battery Charging..	17	FOCUS Control..	15,27
Battery Level Indicator..	20,28-29	FOCUS Indicator..	28,32-33
Battery Safety Precautions..	19	Focusing..	32-33
Battery, Attaching..	18	Handstrap	12,15
Battery, Clock	31	I.ZOOM Indicator..	28,35
Battery, Rechargeable..	11,17-20	Important Safeguards	iv-vii
BRIGHT Control	15,27	INDEX Indicator	25,28-29
Bulb Replacement , Video Light..	57	Indexing, Electronic..	25
Camcorder Operating Controls..	14-15	Information to User..	61
Camcorder, Powering	16-21	<i>INST. ZOOM</i> Button	14,28,35
Camcorder, Recording On..	48-49	Lens Cap Holder	12,15
Camcorder, Unpacking	10	Lens Cap, Remove	12
Car Cord, Optional..	3,20	Lens Hood..	5,14
Card, Registration	1	Lens Hood, Removing	5
Care and Maintenance..	60	LIGHT AUTO/OFF/ON Switch..	14,56
Care and Storage, Battery	19	Light Bulb, Replacing..	57
Care and Storage, Cassette..	23	Light, Built-in	14,56-57
Cassette Door..	12,15,23	Limited Warranty..	62
Cassette Tips	59	Macro Focus	33
Cassette, Inserting and Removing..	12,23	Maintenance and Care..	60
Cassettes, Video..	22-23	Manual Focus..	33
Charging the Battery..	17	Memory Stop..	28,38
Chart of Characters	45	Microphone	14,24
Cleaning the Viewfinder..	27	NO TAPE Indicator..	28-29
Checks and Adjustments..	63-65	Operating Controls, Camcorder..	14-15

Index (continued)

Operation, First-Time	10-15	Shoulder Strap Attachment Rings	15,58
Optional Accessories	2-9	Shoulder Strap, Attaching	58
Optional DC Car Cord	3,21	Solving Problems	63-65
Order Form, Accessories	7-9	SP (Standard Play) Speed	22
Pause Indicator (II)	28,41,43	Specifications	61
Picture Search	51	Stop Action Pause	51
PLAY Button	13,14,39,41,43,50,53,55	STOP/EJECT Button	12,13,14,20,23,24,30,38,41,43,50
Playback on a TV with		Tab, Safety	22
AUDIO/VIDEO IN Jacks	52-53	Table of Contents	1
Playback on a TV without		TAPE Indicator	28-29
Audio/Video Inputs	54-55	TAPE END Indicator	28-29
Playback, First	12	Tape Copying	48-49,52-53
Playback, Viewfinder	50	Tape Positioning	24
POWER (CAMERA/OFF/VCR)		Tilt Adjustment	27
Switch	12,18,24,30-31,41,43,44-46,49,50,53,55,56	Time and Date Display	28-29,30-31
Powering Your Camcorder	11,16-21	Time and Date Recording	31
Problem Solving	63-65	Time Counter	28,38
Product Registration	i	Time Remaining Display	25,28-29
ProEdit® Features	39-46	Tips Traveling	59
Program AE (Auto Exposure)	24	Tips, Cassette	59
Quick Review	24	Tips, Recording	47
REC Indicator	13,28	TITLE SEL Button	14,44-46
REC/PAUSE Button	13,15,38,41,43,46,49,61,53,55,56	TITLE SEL + and - Buttons	14,44-45
Rechargeable Battery	17-20	TITLER Button	14,44-46
Recording on the Camcorder	48-49	Titler	44-46
Recording Speed	22	TRACKING (Also Power Zoom)	15,51
Recording the Date and Time	31	Buttons	15,51
Recording Tips	47	Traveling Tips	59
Recording, First	12	Tripod, Using	6
Registration Card	i	Trouble Checks	63-65
Removing Lens Hood	5	Unpacking the Camcorder	10
Removing the Battery	18	Using a Tripod	6
Replacing Bulb of Video Light	57	Using Adapter/Charger	16
RESET Button	14,38	Using the Rechargeable Battery	17-20
RESET Switch	65	Video Cassettes	22-23
REVIEW Button	14,24	Video Light	56-57
REW (Rewind)		VIDEO/AUDIO	
Button	13,14,24,39,30,41,43,51	Jacks	14,40-41,42-43,48-49,52-53,54
Rewind Indicator (◀◀)	28	Viewfinder	12,14,26-27,50
RF DC OUT Jack	14,54	Viewfinder Playback	50
RF Output Adapter	4,54-55	Warranty, Limited	62
Safeguards, Important	iv-vii	ZM:2 (Digital Zoom) Indicator	28,35
Safety Instructions for AC		ZOOM Indicator	28,35
Adapter/Charger	iii	Zoom (T and W) Buttons	15,34
Safety Precaution	i-11	Zoom Level Control	34
Safety Precautions, Battery	19	Zoom Level Indicator	28,34
Safety Tab	22	Zooming	34-35
Set the Date and Time	30		



For your nearest Home
Entertainment Dealer
or Authorized Servicer
call toll-free in the U.S.A.

1-800-336-1900

Canadian Consumers -
Your toll-free numbers are:

English: 1-800-522-0338

French: 1-800-522-0445

If your camcorder needs service, please
contact your dealer or the nearest Servicer
from the yellow pages. Please do not send
any products to the Indianapolis address listed
in this manual or on the carton. This will only
add delays in service for your product.

Thomson Consumer Electronics
600 N Sherman Dr, PO Box 1976
Indianapolis, IN 46206

©1994 Thomson Consumer Electronics, Inc.
Trademark(s)@ Registered
Marca(s) Registrada(s)
Printed in Japan
Part Number 94-CC543-1
QR10494



Free Manuals Download Website

<http://myh66.com>

<http://usermanuals.us>

<http://www.somanuals.com>

<http://www.4manuals.cc>

<http://www.manual-lib.com>

<http://www.404manual.com>

<http://www.luxmanual.com>

<http://aubethermostatmanual.com>

Golf course search by state

<http://golfingnear.com>

Email search by domain

<http://emailbydomain.com>

Auto manuals search

<http://auto.somanuals.com>

TV manuals search

<http://tv.somanuals.com>