

Distributed by  
**Raymarine**

Any reference to Raytheon or RTN in this manual should be interpreted as Raymarine. The names Raytheon and RTN are owned by the Raytheon Company.

# FishFinder L365

## Instruction Manual

Raymarine

# Contents

Echo sounding – How it works (inside front cover)  
FishFinder L365 – Features and functions i  
For information and service ii

## 1

### **Introduction 1**

About the FishFinder L365 1  
System Components 2  
Standard Equipment 2  
Standard Transducers 2  
Optional Accessories 2

## 2

### **Installation 4**

About the Transducer 4  
Selecting the Correct Type of Transducer 5  
Assembling the Transducer Bracket 6  
Positioning the Transom-Mount Transducer 6  
Mounting the Transom-Mount Transducer 9  
Mounting the Optional Sidelooker Transducer 10  
Installation Notes – Thru-Hull Transducer 11  
Installation Notes – In-Hull Transducer 12  
Installation Notes – Trolling Motor Transducer 13  
Installation Notes –  
    Transducer for Speed and Temperature Only 14  
Mounting the Display Unit – Standard Mount 14  
Dismounting the Display Unit 16  
Mounting the Display Unit – Flush Mount 16  
Installing the Transducer Cable 17  
Installing the Transducer Cable – Sidelooker Option 19  
Installing the Transducer Cable –  
    Separate Speed and Temperature Sensors 20  
Making the DC Power Connections 20  
Calibrating the Sensors 22

## 3

### **Operating Instructions 24**

Controls on Display Unit 24  
Turning the Power On and Off 25  
Setup Memory 25  
Lamp/Contrast Menu 26  
Operating Pages 28

FishFinder Page 29  
Choosing a Frequency 34  
Fish Indications 35  
Bottom Indications 36  
Performance Modes 37  
Zoom Page 38  
A-Scope (Bottom Coverage) Page 40  
Digital Page 42  
Sidelooper Page 43

## 4

### **Setup Instructions 47**

The Setup Menu 47  
Range Setting 48  
Sensitivity Setting 49  
Chart Speed Setting 50  
Zoom Setting 52  
Frequency Setting 53  
Resetting the Log 54  
System Setup Display 55  
    Simulator 56  
    Fish Symbol 56  
    White Line 56  
    Sidelooper 56  
    Speed Cal 57  
    Temp Cal 57  
    Shallow Alarm 57  
    Deep Alarm 58  
    Fish Alarm 58  
    Buzzer 58  
    Depth Units 59  
    Speed Units 59  
    Temp Units 59  
    Speed 59  
    Log 59  
    Temp 59  
Setup Instructions for Sidelooper 60  
Resetting the Unit to Factory Defaults 62  
Default Settings 63

## 5

### **Maintenance and Troubleshooting 64**

Cleaning Instructions 64  
Troubleshooting Suggestions 64  
Servicing a Thru-Hull Transducer 68  
How to Contact Raymarine 68

## 6

### **Specifications 72**

General Information 72  
FishFinder Functions 73  
Connector Diagrams 74  
Glossary of Terms 75

## List of Figures

Figure	Page
Unit in Use	Inside front cover
Front Panel	i
1-1 Typical Installation	1
2-1 Transducer Types	5
2-2 Assembling the Transducer Bracket	6
2-3 Transducer Mounted on Transom	7
2-4 Transducer Bracket, Side View	7
2-5 Correct Mounting Position	8
2-6 Mounting the Transducer	8
2-7 Installing the Sideloooker Transducer	10
2-8 Installing the Sideloooker Transducer - Trolling Motor	13
2-9 Installation on Bracket	14
2-10 Dimensions	15
2-11 Flush-Mount Installation	16
2-12 Disassembling from Bracket	17
2-13 Installing Cable on Transom	18
2-14 Cable for Sideloooker Transducer	19
2-15 Cable for Speed and Temperature Sensor	20
2-16 DC Power Connections	21
3-1 Display Panel	24
3-2 Lamp/Contrast Menu	26
3-3 Selecting DisplayPages	27
3-4 FishFinder Page	29
3-5 Fish Indications	36
3-6 Bottom Conditions	37
3-7 Zoom Page	38
3-8 A-Scope Page	40
3-9 Digital Page	42
3-10 Sideloooker Feature	43
3-11 Sideloooker Page	44
4-1 Moving Through the Setup Menu	47
4-2 Range Settings	48
4-3 Sensitivity Setting	49
4-4 Changing the Chart Speed Setting	50
4-5 Chart Speed Setting	51
4-6 Zoom Settings	52
4-7 Frequency Setting	53
4-8 Resetting the Log	54
4-9 Reaching the System Setup Display	55
4-10 System Setup Display	55
4-11 Sideloooker Range Settings	61
4-12 Sideloooker Sensitivity Settings	62
5-1 Sample Mailing Label	70
6-1 Connector Diagrams	74

---

## 1 - Introduction

---

### About the FishFinder L365

The FishFinder L365 is a system that uses sound waves ("sonar") to detect fish and show the bottom of a lake or sea. The system includes a transducer and a display unit, connected by a cable. The transducer sends high-frequency sound waves down into the water. These sounds strike fish, the bottom, or other objects in the water, and return as echoes. The FishFinder then interprets these echoes and presents a display.

The FishFinder L365 can handle many different jobs:

- detect the presence of fish below the boat
- trigger an alarm when fish are found
- measure the depth of the water
- set alarms for minimum and maximum depth
- show the shape of the bottom
- determine whether the seabed is hard or soft
- measure the speed of the boat and the distance traveled
- show the water temperature

We are sure you will find the FishFinder L365 to be one of the most useful devices on your boat.

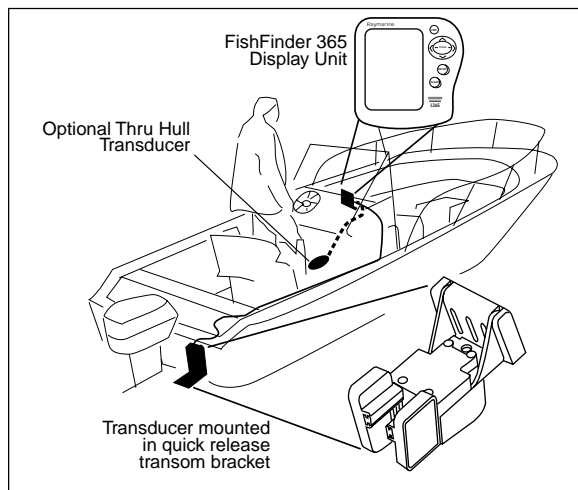

**Fig. 1-1**  
Typical Installation

## System Components

The FishFinder L365 consists of a compact display unit connected to a transducer. The transducer is attached to the boat and extends into the water.

## Standard Equipment

When you unpack your FishFinder L365, you should find the following standard equipment in the carton. If any items are missing, please notify your Raymarine dealer immediately, or contact the Customer Service Department at Raymarine at 1-800-539-5539, ext. 2333. Please provide the serial number of the FishFinder when reporting any missing items.

Description	PartNo.
FishFinder L365 display unit	E61010
Quick-release swivel-mount bracket (with mounting hardware)	M78945
DC power cable	M99-146
Instruction manual	G627296-3
Four #10 x 3/4" ss mounting screws	—

## Standard Transducers

Depending on which model of the L365 you have purchased, the box will include one of the transducers listed below:

Description	PartNo.
Transom-mount transducer (with speed and temperature sensors, including mounting bracket and hardware)	M78898
Bronze thru-hull transducer (with speed and temperature sensors)	M78923

## Optional Accessories

Optional accessories and parts can be purchased directly from Raymarine. For prices and ordering information, please call the Parts Department at (800) 539-5539 ext. 2333.

Description	Part No.
Sidelooker transom-mount transducer	M78930
Sidelooker transducer for trolling motor mounting. Companion with M78928 downlooker depth/temp transducer, with 12 ft. (3.6 m) cable and hardware	M78929
Extension for transducer cable (15 ft, 5 m)	M99-140
Extension for transducer cable, for Sidelooker transducer (15 ft, 5 m)	M99-139
Flush-mounting kit (with hardware and mounting template)	M99-137
Fairing block for M78923 thru-hull transducer (Lexan®)	M99-142
Low profile plastic thru-hull transducer (Valox® plastic, sensor for depth only)	M78922
Bronze thru-hull transducer (sensor for depth only)	M78921
In-hull/trolling motor transducer (for installation in fiberglass hull only, or mounting on trolling motor, including hardware for either installation)	M78928
Angled in-hull transducer (for installation in fiberglass hull only, where deadrise angle is 10° to 22°)	M78946
Plastic thru-hull transducer (Valox® plastic, with speed and temperature sensors, used with depth-only transducers M78922, M78928, M78946)	M78937
Transom-mount speed and temperature sensor (used with depth-only transducers M78922, M78928, M78946)	M78936
Replacement transom transducer mounting bracket kit	M99-148
Soft storage/carrying case	M99-114
Transducer switch box (select between two L365 FishFinder displays, using one transducer)	M99-136
Replacement paddle wheel kit (for transom-mount transducer)	M99-143
Replacement paddle wheel kit (for thru-hull transducer)	M99-144



---

## 2 - Installation

---

The installation process has four parts:

- Mounting the transducer
- Mounting the display unit
- Connecting the cables for the transducer and power supply
- Calibrating the display unit

### About the Transducer

Several different kinds of transducers can be used with this unit. The transom-mount style, used most often, and in-hull types are shown in Fig. 2-1.

Besides measuring water depth, the transducers also have two other sensors: a paddle wheel which detects the speed of the boat, and a sensor for the water temperature. The display unit uses the speed information to calculate the distance the boat has traveled. An optional transducer, the Sidelooker, detects objects by looking out to the sides of the boat.

Since the transducer is very important to the operation of the FishFinder, it is vital that the transducer be mounted correctly. The transducer will give the most reliable readings if it looks into water which is smooth and undisturbed. If you place the transducer so bubbles or turbulence flow across the face of the unit, the system may give inaccurate readings.

There are three important rules when mounting any type of transducer:

- The transducer should be continuously covered by water when the boat is moving. (If the transducer is mounted near the side of the boat, it may be exposed when the boat is turning.)
- The transducer should be placed where turbulence or bubbles will not pass directly over the face of the unit. Don't place the transducer behind any running strakes, intakes, or thru-hull fittings which create turbulence.
- The transducer should be mounted where it will not be affected by the wash from the propeller(s).

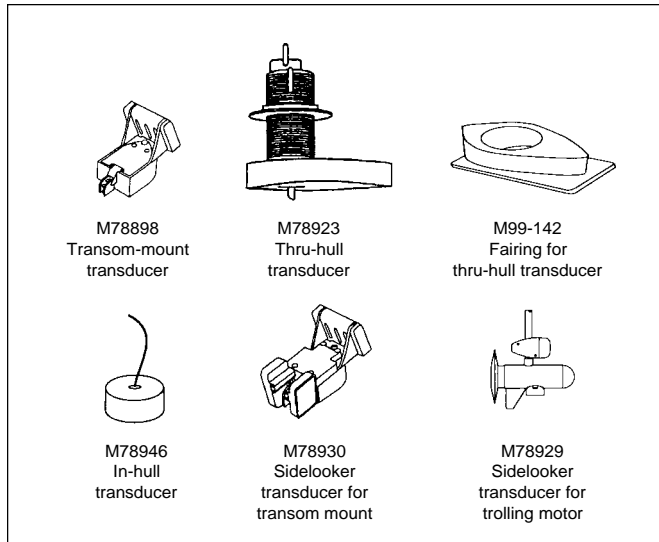

**Fig. 2-1**  
Transducer  
Types

## Selecting the Correct Type of Transducer

Before you begin the installation, double-check to be sure you have the correct type of transducer. Each kind of transducer is designed for a particular type of use. In this manual we will include detailed mounting instructions for the transom-mount transducer. We will also include some general information on the other types. For detailed information on these other transducers, see the instructions which are packaged with the unit.

### **Use a transom-mount transducer if –**

... your boat has an outboard or inboard-outboard engine(s), and if you're planning to use the Sidelooker option. This type of transducer must be mounted ahead of or beside the propeller(s). Do not use this type of transducer for a boat with a straight-shaft inboard engine.

### **Use a thru-hull transducer if –**

... your boat has a straight-shaft inboard engine. This type of transducer is installed in a hole drilled through the hull.

### **Use an in-hull transducer if –**

... you have a high-speed boat or if, for some reason, you cannot use a transom-mount or thru-hull transducer. The hull may be no more than 1" thick.

**Use a trolling motor transducer if –**

... you want to attach the transducer to a trolling motor. (Not recommended for deep-water operations.)

**Use a Sidelooker transducer if –**

... you need a way of searching for fish on either side of the boat. This type of transducer is attached to the bracket of the transom-mount transducer or to the shaft of the trolling motor.

### Assembling the Transducer Bracket

Fit together the two parts of the transducer bracket as shown in Fig. 2-2. When the installation is complete, the parts snap together as shown.

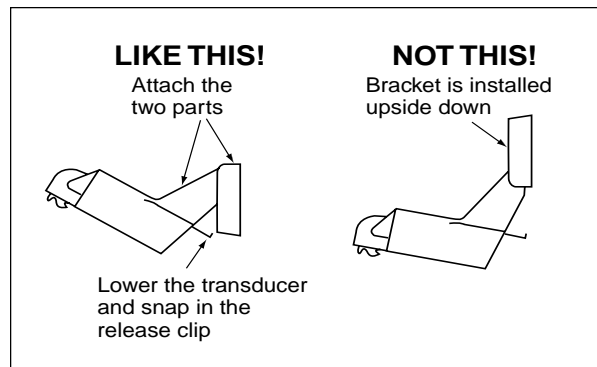
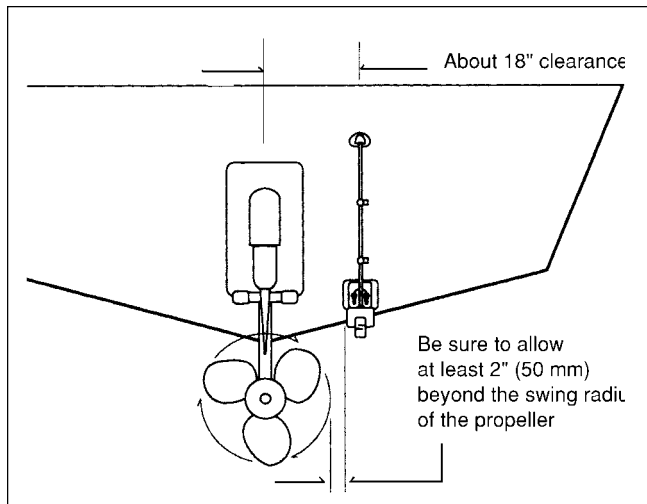

**Fig. 2-2**  
Assembling  
the Transducer  
Bracket

### Positioning the Transom-Mount Transducer

Begin by finding the best location for the mounting bracket. Here are the rules:

- If your boat has one propeller (outboard or inboard-outboard), mount the transducer about 18" (455 mm) to the side of the centerline of the boat. See Fig. 2-3. Choose the side that is on the downstroke of the propeller. (This is usually the starboard side of the boat.) This will reduce interference caused by air bubbles.
- If the propeller can be turned to steer the boat, allow at least 2" (50 mm) beyond the swing radius of the propeller. This will prevent the



**Fig. 2-3**  
Transducer  
Mounted on  
Transom

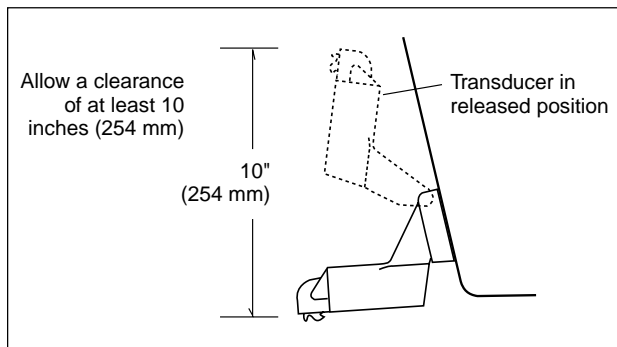

**Fig. 2-4**  
Transducer  
Bracket,  
Side View

propeller from damaging the transducer when it is turned. After installation, check the clearance by turning the wheel so the propeller swings toward the transducer. There should always be a 2" (50 mm) clearance.

- If your boat has twin propellers (outboard or inboard-outboard), place the transducer near the centerline of the boat.
- **Do not** mount the transducer behind any hull fittings, intakes, or other parts which extend from the hull. These may cause turbulence or air bubbles.

Installation

7

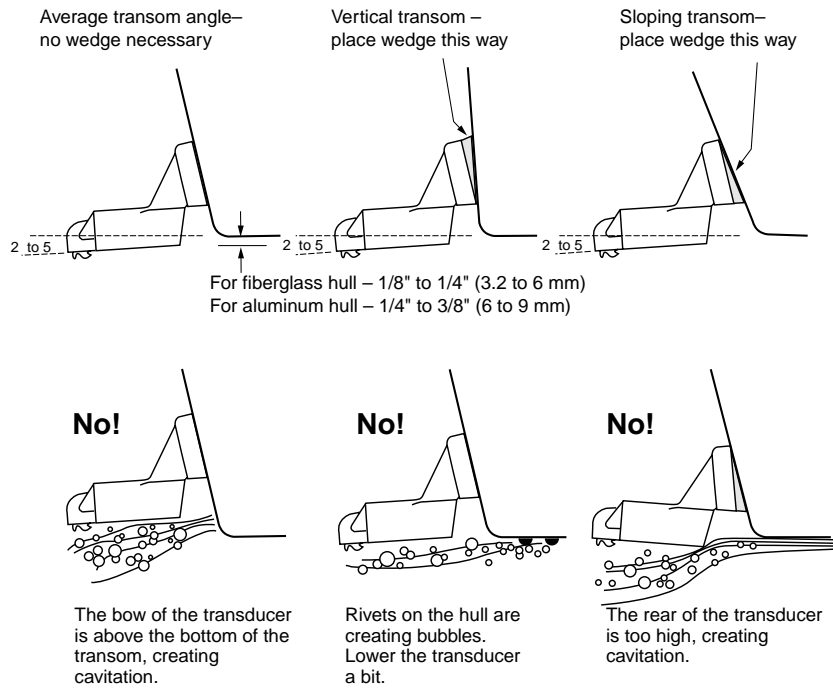

**Fig. 2-5**  
Correct Mounting  
Position

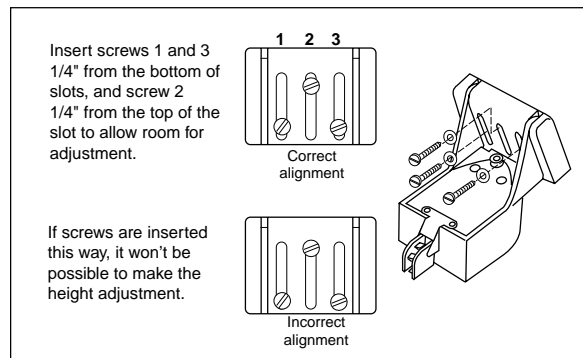

**Fig. 2-6**  
Mounting  
the Transducer

- The bracket has a quick-release mechanism. This may reduce damage by allowing the transducer to flip up if it hits any debris or the bottom. See Fig. 2-4. Allow enough clearance above the transducer so that it can swing upward completely. This is about 10" (254 mm) measured from the bottom of the transom.
- If considering the Sidelooker option, look for a mounting location where the Sidelooker array will not be blocked by the engine housing or other mounted hardware.
- If the boat will be carried on a trailer, be sure the transducer will not hit any rollers, bunks or fittings on the trailer.

### Mounting the Transom-Mount Transducer

1. On a boat with a fiberglass hull, the leading edge of the transducer should extend 1/8" (3.2 mm) to 1/4" (6 mm) below the bottom edge of the hull. See Fig. 2-5. On an aluminum hull, the transducer should extend a bit more – 1/4" (6 mm) to 3/8" (9 mm). If the boat will be operated at high speeds, the transducer may be mounted closer to the centerline of the hull.
2. The lower surface of the transducer should tilt down toward the rear at a slight angle (2° to 5°). The mounting bracket includes a wedge. Depending on the angle of the transom on your boat, you may need this wedge to get the correct angle for the bottom of the transducer.
3. Looking at the rear of the boat, be sure the bracket is vertical (perpendicular to the water line).
4. Hold the bracket (and the wedge, if used) against the transom and trace the positions of the screw slots.
5. Remove the bracket. See Fig. 2-6. The screws in the outer slots should be placed about 1/4" (6 mm) up from the bottom of each slot. The screw in the center slot should be placed 1/4" (6 mm) down from the top. (This will allow you to adjust the bracket up or down a bit.) Drill pilot holes 3/4" (19.1 mm) deep. Use a 9/64" (3.6 mm) drill bit. To prevent drilling too deeply, wrap masking tape around the drill bit about 7/8" (22 mm) from the tip. Drill in only as far as the tape marker.  
If you are attaching the bracket to a fiberglass hull, you can minimize any surface cracking of the gel coat. Before drilling each pilot hole, drill a shallow hole (chamfer) at each location about 1/16" (1.5 mm) deep. Use a 1/4" (6 mm) drill bit.

6. Attach the bracket to the hull using the panhead screws with flat washers. Before you tighten the screws, apply a good-quality marine sealant to the pilot holes. This will protect the hull from water penetration. **Do not tighten the screws completely yet.**
7. Move the bracket up or down so that the leading edge of the transducer has the clearance shown in Fig. 2-5.
8. Once the bracket is in the correct position, you can tighten the screws.

### Mounting the Optional Sidelooker Transducer

1. The Sidelooker transducer allows the display unit to check the water to either side of the boat. This is helpful when you are looking for fish or structure near river banks, or under docks or piers.

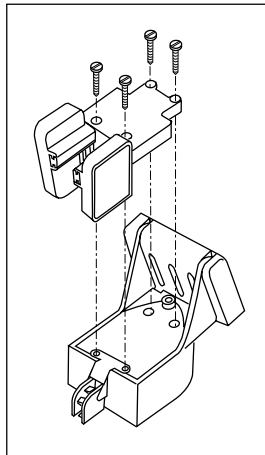

**Fig. 2-7**  
Installing the  
Sidelooker  
Transducer

2. The M78930 Sidelooker transducer is attached to the same mounting bracket used with the transom-mount transducer. See Fig. 2-7. Begin by installing the transom-mount bracket as described earlier.
3. Remove the two screws and brackets covering the paddlewheel.
4. Attach the Sidelooker transducer to the top of the transom mounting bracket. Use the four panhead screws supplied. The fit should be snug, but do not overtighten the screws.

5. Run the Sidelooker cable beside the depth cable for the transom-mount transducer.

### Installation Notes – Thru-Hull Transducer

Detailed instructions for this installation will be included with the transducer. In this section, we will note just a few important points.

1. Earlier we listed three general rules for placing transducers. All of these rules apply when you are mounting a thru-hull transducer. Here are some other rules for selecting the best mounting location:
  - For planing hulls** – Install in the flat planing area near the stern. Always install forward of the propeller(s) and shaft(s).
  - For small displacement hulls** – Install near the centerline of the hull and 1/3 of the way forward from the stern. Always install forward of the propeller(s) and shaft(s).
  - For large displacement hulls** – Install near the centerline of the hull and 1/3 of the way aft from the bow. Always install forward of the propeller(s) and shaft(s).
  - For sailboats** – Install forward of the leading edge of the keel, to one side and near the centerline of the hull.
2. Choose a location where you can easily reach the transducer from inside the boat. This will allow you to service the unit. Allow at least 6" (152 mm) of headroom above the transducer.
3. When choosing a mounting location, drill a small pilot hole (1/8" or 3.2 mm) from the inside of the hull. Before you drill the hole, be sure you will be able to reach the large nut on the top of the unit, and that there will be enough clearance for the cable. If there is a strake or other feature on the hull, drill from the outside of the hull instead. (This small hole can be filled easily if the mounting location is not suitable.)
4. The position of the transducer is especially critical on high speed boats (capable of more than 20 knots). Check the locations of the transducers on similar boats before installing the transducer in your own boat. Choose the location which will offer the best performance.
5. If the bottom of the hull at the mounting location is flat, you can mount the transducer directly through the hull. If the hull rises at an angle (the "deadrise angle") of more than 10°, you must include a mounting block or "fairing." The transducer must be mounted in a vertical position. Attach the fairing block to the hull as firmly as possible. This



fairing block must be able to resist the drag of the water against the hull, and must also be completely waterproof.

6. If the hull of the boat has a core-type hull, you will need to follow some special mounting procedures. The core material must be protected from any water which may leak from the inside of the boat. (If the core material is allowed to remain wet, it may rot and weaken the hull.)
7. When working with the transducer, support it by holding the body of the unit or the rings. Do not hang the transducer from the cable.
8. It is very important to seal the opening around the transducer using a high-quality marine sealant suitable for underwater use. After installation, do not leave your boat in the water for any amount of time without checking for leaks.

### Installation Notes – In-Hull Transducer

Detailed instructions for this installation will be included with the transducer. In this section, we will note just a few important points.

1. Choose the best mounting location:
  - For outboard powerboats** – Install as far aft as possible
  - For inboard/outboard powerboats** – Install close to the engine(s)
  - For inboard powerboats** – Install forward of the propeller(s) and shaft(s)
  - For sailboats** – Install near the centerline of the hull and forward of the leading edge of the keel
2. An in-hull transducer may only be installed in a fiberglass hull which is no more than 1" (25 mm) thick. The in-hull transducer may not be installed in wood or aluminum hulls.
3. Use the standard in-hull transducer if it will be installed in a flat part of the hull, or a section with no more than 10° of deadrise. Use the angled in-hull transducer if the mounting location has up to a 22° of deadrise.
4. Do not try to compensate for the angle of the hull by fairing the epoxy adhesive on the face of the transducer.
5. Use the epoxy supplied with the in-hull transducer, or an equivalent epoxy glue. Do not use any other type of adhesive, including silicone or RTV adhesive.

## Installation Notes - Trolling Motor Transducer

Both Downlooker and Sidelooker transducers may be installed on a trolling motor. See Fig. 2-8.

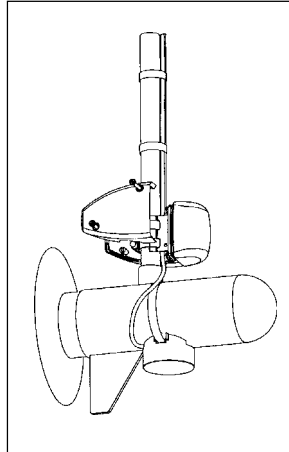

**Fig. 2-8**  
Installing the  
Sidelooker  
Transducer on a  
Trolling Motor

Detailed instructions for these installations will be included with the transducer(s). The Downlooker transducer is mounted on the horizontal gear case of the motor. The Sidelooker transducer is attached to the vertical support tube. These installations are simple, but it is important to keep these points in mind:

1. Keep the Sidelooker transducer fully submerged. The transducer will only produce an image if it is immersed in water.
2. Keep the Sidelooker transducer clear of weeds or debris.
3. When the position of the trolling motor is changed, the field of view of the Sidelooker also changes. The Sidelooker can be aimed at interesting echoes, but can also be positioned so that it is looking back at the hull. Be aware of the position of the Sidelooker transducer.

## Installation Notes – Transducer for Speed and Temperature Only

This type of transducer may be used with a thru-hull transducer which reads depth only. The speed/temperature transducer is attached to the transom of the boat. Detailed instructions for this installation will be included with the transducer. The cable for this transducer uses a “Y” connector. See the notes on “Installing the Transducer Cable.”

### Mounting the Display Unit – Standard Mount

You may mount the display unit on any flat surface using the bracket supplied. See Fig. 2-9. (There is also an optional kit which allows you to flush-mount the display in a flat panel or dashboard). Follow these instructions if you are using the standard mounting bracket:

1. The “LCD” type display used on this unit is easier to see from certain angles. Before selecting a permanent mounting location, make temporary power connections and turn on the unit. This will allow you to test the visibility of the display from several different angles.
2. Remove the display unit from the bracket by pressing on the large button in the center of the bracket. See Fig. 2-9.
3. Mount the base of the bracket using the supplied screws.

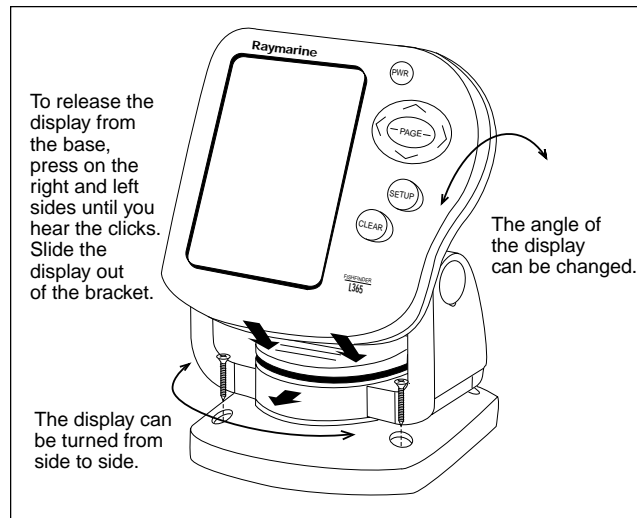

**Fig. 2-9**  
Installation  
on Bracket

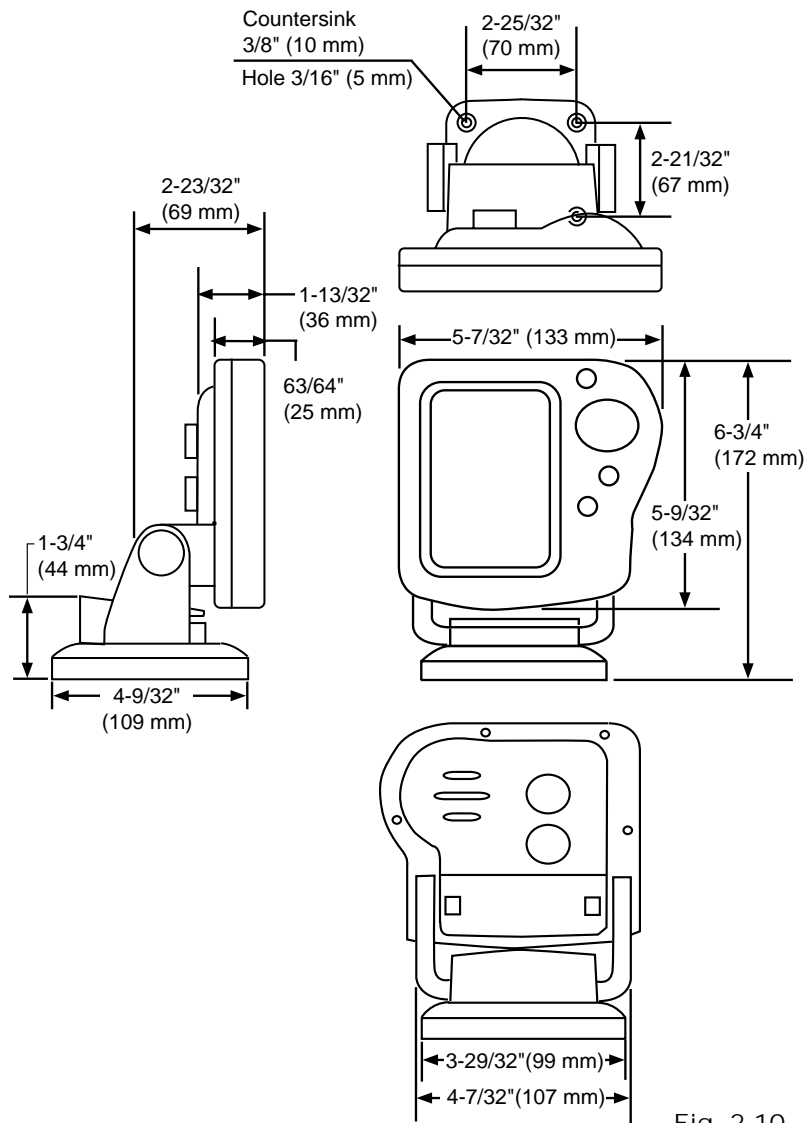

**Fig. 2-10**  
Dimensions

4. Slide the display unit back into the bracket.
5. Adjust the display unit for the best viewing angle. You can turn the display from side to side, and tilt it up or down.

### Dismounting the Display Unit

See Fig. 2-9. To release the display from the bracket, press and hold down the left and right sides. You will hear an audible "click," and the bracket will slide out.

### Mounting the Display Unit – Flush Mount

In order to do this installation, you will need the optional flush mounting kit (part no. M99-137). See Fig. 2-11.

1. Select a mounting location on the dashboard or control panel. Choose a clear, flat area at least 6" x 6" (152 mm x 152 mm). Be sure you will also have at least 6" (152 mm) of clearance behind the area where the display unit will be mounted. It is a good idea to drill a small pilot hole in the center of the mounting area. Be sure there are no hidden electrical wires or other items behind the point where you plan to mount the display unit.
2. A mounting template is supplied with the flush mounting kit. Tape this over the selected location on the panel and trace around the edges.
3. Make the cutout for the display. Drill a series of 1/2" (13 mm) holes at the points shown around the edges of the cutout area.

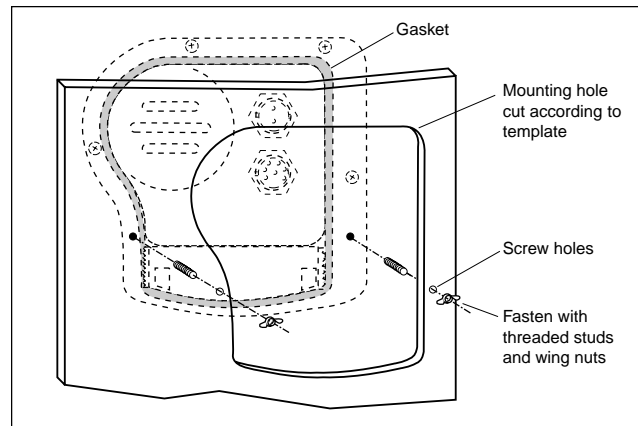

**Fig. 2-11**  
Flush-mount  
Installation

4. Drill the two small holes for the threaded studs as shown on the mounting template. Use a 7/32" (5.5 mm) drill bit.
5. Remove the template and draw straight lines between the 1/2" holes. Cut along each of the lines with a small saw.

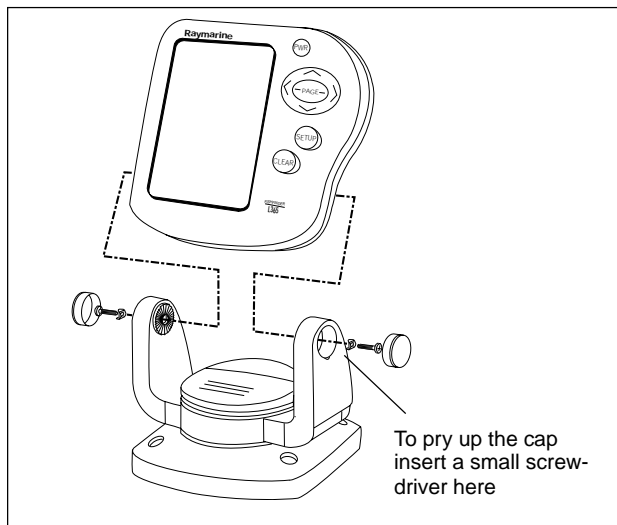

**Fig. 2-12**  
Disassembling  
from Bracket

6. Separate the display unit from the mounting bracket. (See Fig. 2-12.) Press the large button in the center of the bracket to separate the bracket arms. The display unit is attached to the arms by two screws. Each screw is covered by a cap. Locate the small slot beside each cap and pry upward using a small screwdriver. Remove the caps, then the two screws and the two wave washers. Save these parts in case you ever want to use the mounting bracket.
7. Screw the threaded studs into the holes on the rear of the display unit.
8. Set the display unit into place to be sure that it will fit correctly. Thread the wing-nuts onto the threaded studs to hold the display unit in place temporarily.
9. Once the DC wiring is complete, finish the installation. Hold the gasket in place around the opening. Fit the display into the cutout again. From the rear, screw the thumbscrews securely onto the threaded studs to hold the unit in place.

## Installing the Transducer Cable

A 20 foot length of cable, with the connector attached, is supplied with the transducer. **During the installation, do not cut the transducer cable or remove the connector. Do not try to shorten or splice the cable. The transducer cable includes several wires, along with shielding and insulation. If the cable is cut, it cannot be repaired.** (Cutting the cable will also void the warranty.) During installation, if you need to drill any holes for the cable, they must be large enough to accept the connector. This will allow you to make the installation without cutting the wire.

1. Route the cable up and over the top edge of the transom. See Fig. 2-13. Secure the cable using cable clamps. (These clamps are available from your local marine equipment supplier.)  
If you do not want to expose the cable on the deck, you may drill a new hole (3/4" or 19 mm) through the transom for the cable. (Remember – this hole must be large enough to accept the cable with the connector attached. Do not cut the cable!) To seal the opening, use a feed-thru cap where the cable passes through the transom.
2. Run the cable through the interior of the boat. If the transducer cable runs near another electrical wire, it may pick up electrical interference or "noise." To reduce this, try to keep the transducer cable separated as far as possible from all other wires. This is especially important with wiring for the boat's ignition, alternator, or tachometer. Also try to

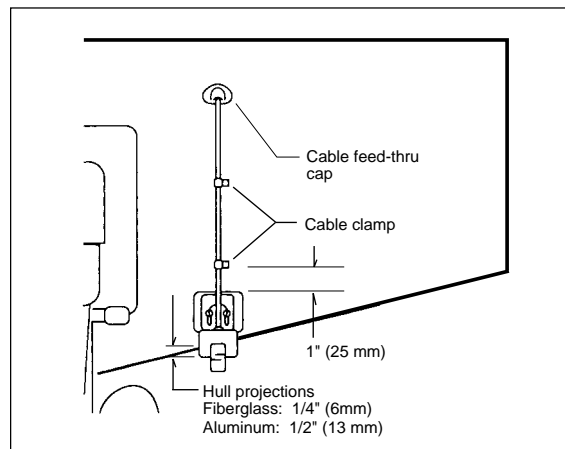

**Fig. 2-13**  
Installing Cable  
on Transom

keep the transducer cable away from the antenna and power cables for VHF or FM radios. It is also helpful to keep the transducer cable away from the FishFinder power cable. If it is necessary to run the transducer cable across any wires, make the crossing at a right angle.

3. Be careful not to tear the cable jacket when passing it through bulkheads and other parts of your boat. Secure the cables in place using tywraps or lacing twine. Coil the extra cable and tie it out of the way.
4. If the 20 foot transducer cable is not long enough, a 15 foot extension cable (4.6 m) is available from your Raymarine dealer (part no. M99-139). When you attach the extension cable, be sure that the connections are tight and watertight. Use Dow Corning DC-4 or an equivalent sealing compound to protect the connector assemblies.
5. At the rear of the display unit, plug in the transducer cable using the keyed connector.

#### Installing the Transducer Cable – Sidelooker Option

1. If the installation includes the optional Sidelooker transducer, there will be two transducer cables. See Fig. 2-14. The cable from the Sidelooker includes a “Y” connector.
2. Plug the cable from the depth transducer into the open end of the “Y” connector.

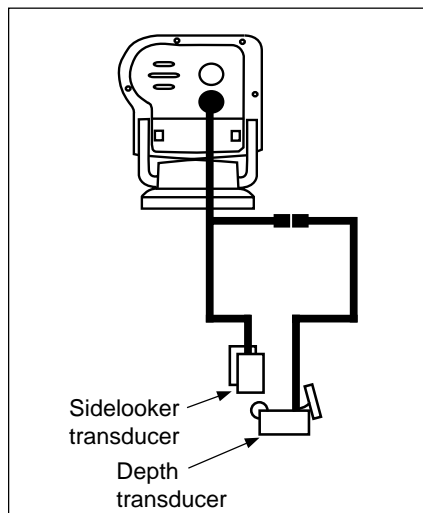

**Fig. 2-14**  
Cable for  
Sidelooker  
Transducer

Installation

19



### Installing the Transducer Cable – Installation with Separate Speed and Temperature Sensors

1. Optional depth-only and speed- and temperature-only transducers are available for the FishFinder L365. In this optional configuration the separate transducers are connected via a “Y” type receptacle cable located on the optional speed- and temperature-only transducer cable.
2. Plug the cable from the depth-only transducer into the receptacle connector on the optional speed- and temperature-only transducer. The speed- and temperature-only transducer then connects at the transducer receptacle of the FishFinder L365. This is shown below in Fig. 2-15.

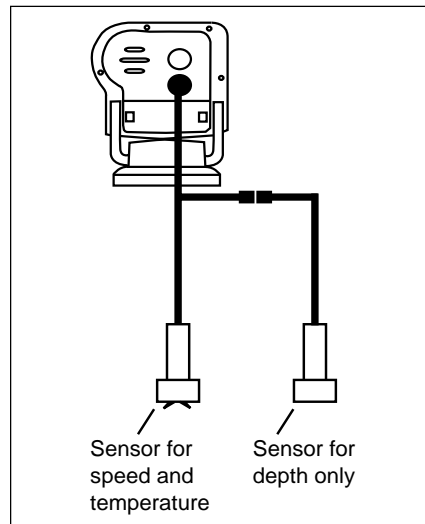
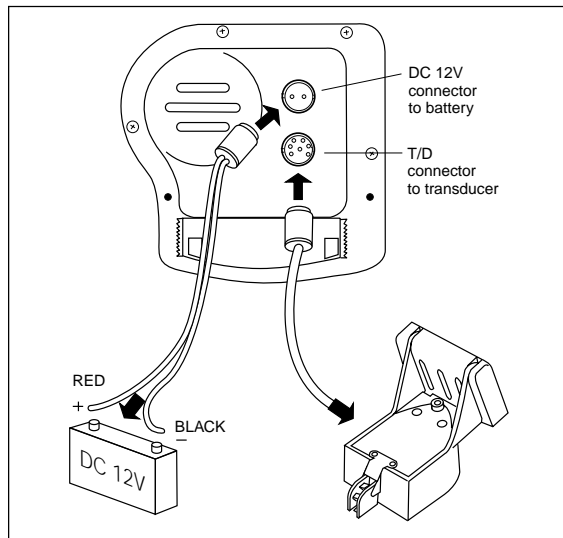

**Fig. 2-15**  
Cable for Speed  
and Temperature  
Sensor

### Making the DC Power Connections

1. The display unit is designed for use on boats with 12V DC power systems. (The unit can operate as long as the DC voltage is between 11.0 and 16V DC.) The display unit can be wired to a negative-ground system, or both the negative and positive supply lines may be “floating” above ground. ***This unit is not intended for use on boats with positive ground.***

2. The 5-foot power cable (1.5 m) supplied with the display unit should reach the source of DC power. On a small boat, connect the power leads directly to the main battery isolation switch or breaker. On a larger boat, route the power leads to the DC power distribution panel.
3. It is very important that you connect the power leads correctly. See Fig. 2-16. At the power source, connect the **red** wire to the **positive** terminal (+), and the **black** wire to the **negative** terminal (-). The negative terminal may also be called "ground" or "earth." (The display unit is internally protected if you accidentally reverse the polarity of the power wires.)
4. Attach the red or positive wire to a 5 amp circuit breaker. If the unit is connected directly to the boat's battery, include a 2 amp in-line fuse. (In-line fuses are available at most marine supply stores.)
5. To prevent any interference or electrical noise, separate the FishFinder power wiring as much as possible from other devices. Avoid running the FishFinder power wires near the power wiring for any radar, radio, or Loran-C units. If possible, wire the FishFinder power wires to a separate circuit breaker.
6. If you need to extend the power wiring by more than 10 feet, use a larger wire size. This will allow the wires to deliver the correct voltage



**Fig. 2-16**  
DC Power  
Connections

in spite of the longer wire distance. For runs of 20 to 35 feet (6 to 10.6 m), use #14 AWG.

If you extend the power wiring, be sure all electrical connections are solid and durable. Soldering is the best way to make these connections. Insulate all connections using heat-shrink tubing or electrical tape. You may also use crimp connectors or a terminal strip, but be sure to use good-quality marine-grade parts.

7. At the rear of the display unit, plug in the power wires using the keyed connector.
8. When you press the **[PWR]** button, the display unit should turn on. If the unit will not turn on and you suspect that you may have reversed the power connections, check the DC power lines all the way back to the battery. If the polarity is not correct, reconnect the leads properly and try again.

## Calibrating the Sensors

The transducer most often used with this unit includes sensors for boat speed and water temperature. These sensors are normally very accurate, but you may want to calibrate them. The procedure appears in the section on the System Setup Menu (page 55).

The speed indication on your FishFinder is usually very accurate. However, there are some special cases where the speed reading may be high or low. This means that the speed of the water past the transducer may not be the same speed that your boat moves through the water. The hull of the boat may have a shape which channels water past the transducer at a speed which is faster or slower than normal.

1. To calibrate the speed sensor, set up a course between two known points. As markers you can use buoys, range markers, or landmarks. Measure the length of time the boat takes to cover a known distance.
2. You may also use locations indicated by a G.P.S. or Loran unit. (If you choose this method, remember that these devices measure "speed over ground" or "speed over the bottom." Tides, currents, or winds can create a difference between the FishFinder's "speed through water" measurement and the boat's "speed over ground." Before calibrating using a G.P.S. or Loran unit, wait for still water or slack tide conditions.

3. If the display unit is reading high or low, you can correct for this using the entry for "Speed Cal." (To reach Speed Cal, go to the System Setup display. This is described in Section 4.) The entry for Speed Cal is a percentage. An entry of "100" equals 100%, meaning that there is no correction. If the display unit is producing a **low** reading, use a **higher** value for Speed Cal. If the display unit is reading **high**, use a **smaller** number for Speed Cal. You may enter any value between 75 and 125.
4. The temperature sensor is usually very accurate, but you can adjust the calibration using the entry for "Temp Cal."

Final note: After you finish the installation, please remember to fill out the Warranty Card included with this manual.

## 3 – Operating Instructions

In this section of the manual, we will explain how to operate the unit. (Setup instructions are included in the next section.) Below is a drawing of the display unit.

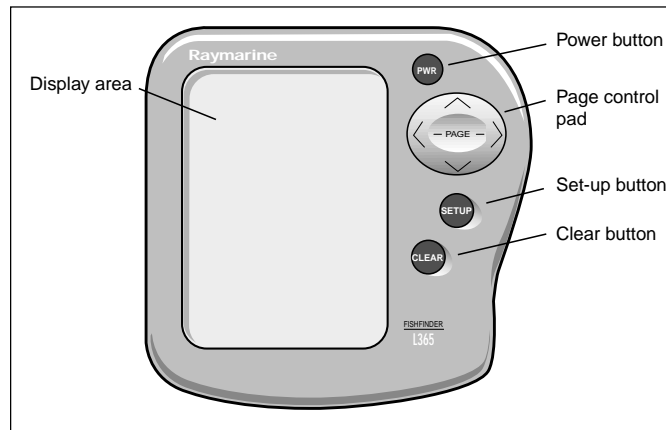

**Fig. 3-1**  
Display Panel

### Controls on Display Unit

The FishFinder is designed to be easy to use while the boat is moving. You can steady your hand by gripping the right side of the display with the fingers of your right hand. This will allow you to use your right thumb to press the buttons on the display.

Notice that some of the buttons can be used in two ways. They do one job during a normal display, and a different job when you are setting up the unit. In this section, we will use the symbols **PWR**, **SETUP** and **CLEAR** to indicate the power, setup and clear buttons.

**PWR**

This button turns the power on and off.

**To turn on the power** – Press once to turn the power on.

**To enter the Lamp/Contrast menu** – Press **PWR** quickly at any time to enter the “Lamp/Contrast” menu.

**To turn off the power** – If you press and hold the button,

the display will say "Powering Off." If you hold the button for more than 3 seconds, the display unit will switch off.

Page control  
pad

*Up and down arrows – ( ^ and v )*

**During setup** – Use these controls to call up a choice or move to the next line on a menu.

**If the Zoom display is turned on** – If the manual zoom feature is turned on, these will move the zoom display up or down.

*Left and right arrows – ( < and > )*

**During normal display** – Use these buttons to go to the next display.

**During setup** – Use these arrows to make a choice within a line on the menu.

**SETUP**

**To enter the Setup Menu** – Press **SETUP** at any time.

**To go to the System Setup display** – Press this button twice.

**CLEAR**

**During normal display** – When an alarm is triggered, use **CLEAR** to turn off the buzzer. (The alarm will continue).

**During setup** – Once you make a change, press **CLEAR** to save the change and go back to the normal display.

## Turning the Power On and Off

Press the **PWR** button once to turn on the power. For a few seconds, the Lamp/Contrast Menu will appear and the panel light will flash on and off. The light will help you to set up the display in the dark.

To turn the power off, press and hold the **PWR** button for more than 3 seconds.

## Setup Memory

When you first turn on the power, the unit will be prepared to operate using a number of preset values. These "default" values are stored in the unit at the factory. (The default values are listed in Section 4.)

This unit has a memory for some of the settings – range, sensitivity, zoom, and frequency. (We will explain these in a moment.) When you turn off the power, any changes you make to these settings will be saved. You can return all of the settings to the factory default values, and reset the trip log to zero. To reset the unit, turn it on by pressing the **PWR** and **CLEAR** buttons at the same time.

### Lamp/Contrast Menu

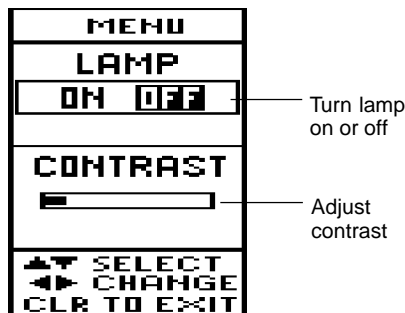

Fig. 3-2  
Lamp/Contrast Menu

Press **PWR** The Lamp/Contrast Menu appears when you first press the **PWR** button and turn on the power. (You will be able to see part of the main FishFinder display behind the Lamp/Contrast menu.)

You can press the **PWR** button a second time to exit from the Lamp/Contrast menu and go directly to the FishFinder mode. (If you do not make any changes to the settings within 7 seconds, the unit automatically exits from the Lamp/Contrast menu anyway.)

You can also enter the Lamp/Contrast menu from any of the other displays by pressing the **PWR** button for a moment.

Turn on lamp The display unit includes a backlight which allows you to read it at night. If you want to turn on the lamp, use either the < or > arrows of the Page control pad.

Fig. 3-3  
Selecting  
Display  
Pages

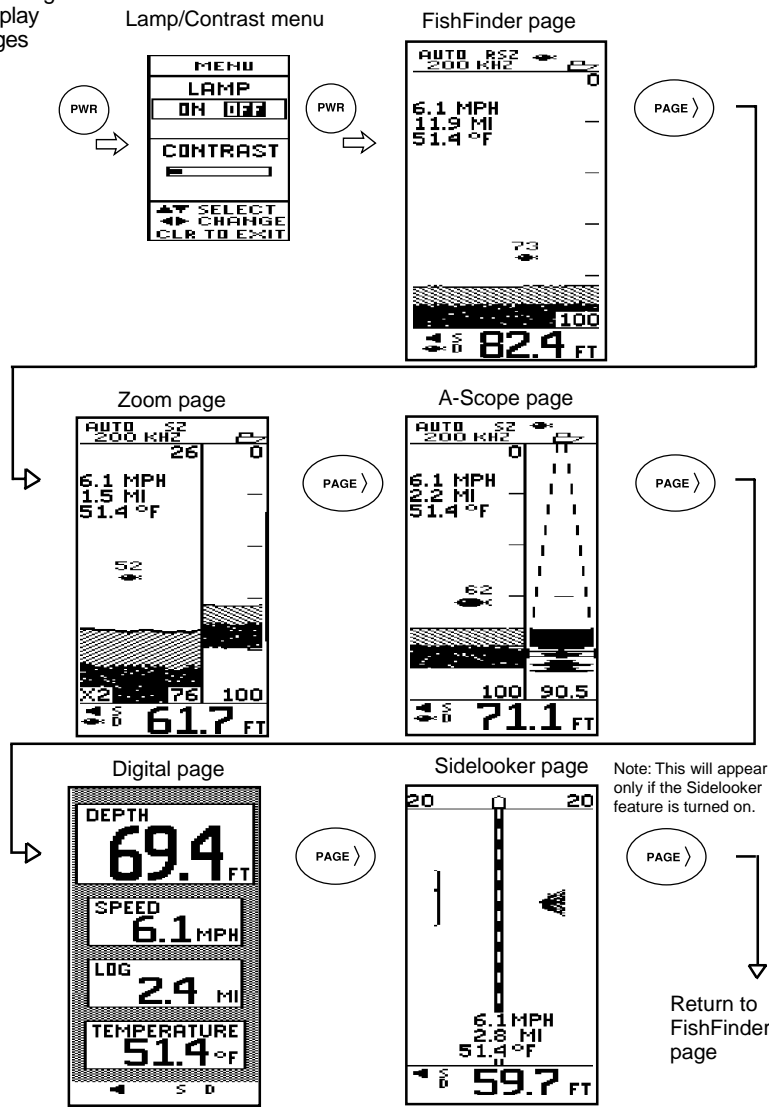



**Adjust contrast** You can also adjust the “contrast” of the display. This is a measure of how light or dark the display appears. Use the V control to move from the line for “Lamp On/Off” to the line for “Contrast.” Use the < or > controls to adjust the contrast. (The FishFinder unit has a feature which adjusts the contrast automatically to compensate for changes in air temperature.)

**Save settings** When the settings on this display are correct, press the **CLEAR** button to save the settings and go to the FishFinder page.

## Operating Pages

This unit has 5 “pages” or normal displays. These can be used to show different kinds of information. Here is a list of the modes:

Mode	Function	See page
FishFinder page	Standard operating mode, good general coverage of bottom.	page 29
Zoom page	Magnified view of smaller section of bottom.	page 38
A-Scope page	Detailed view of area under transducer.	page 40
Digital page	Numerical display of depth, speed, distance traveled and water temperature.	page 42
Sidelooker page (using optional Sidelooker transducer)	View of either side of centerline of boat, (used only with Sidelooker transducer)	page 43

You can step from one of these pages or displays to another using the < and > arrows of the Page control pad. See Fig. 3-3.

There are two other kinds of displays you can see here:

- The system includes several setup displays which can be used to change some of the controls used by the unit. See Section 4.
- When the Simulator Mode is switched on, the unit generates its own display without receiving signals from the transducer. This mode is used for sales and training.

## FishFinder Page

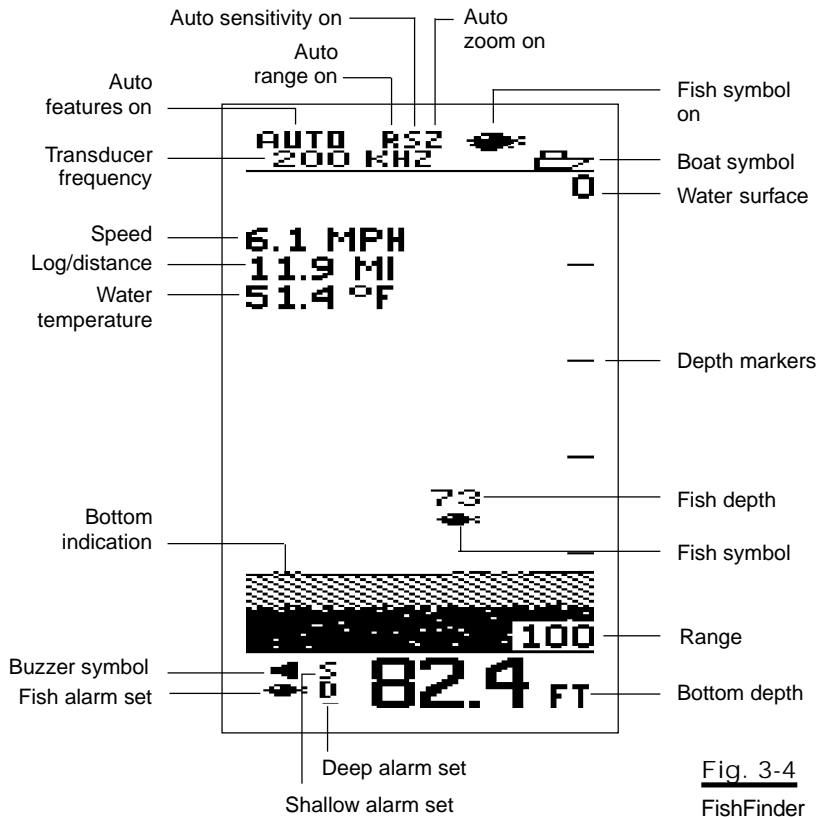

**Fig. 3-4**  
FishFinder  
Page

A moment after you first turn on the display unit, the Lamp/Contrast menu disappears. The unit then automatically switches to the FishFinder page. Figure 3-4 shows a typical display. (The FishFinder page is also called the "chart" or "bottom graph" display.) As time passes, this display scrolls from right to left. The scrolling image becomes a record of the echoes and the bottom seen by the FishFinder as your boat moves.

The images at the right side of the display show the most recent echoes.

Some of these echoes indicate fish, and others show the bottom. As new echoes are received, the FishFinder “draws” a graph of the bottom. The bottom graph helps you to tell whether the bottom is rising or falling. It also allows you to identify the shape or “structure” of the bottom. This can indicate a reef or shipwreck.

Notice that the scrolling speed of the display does not necessarily match the speed of the boat. The scrolling speed of the display is called the “chart speed.” You can adjust this using the “System Setup Menu.” (See Section 4.)

Many of the items on this display appear in the other modes. Since you are likely to use the FishFinder page most often, we will explain all of these items here.

#### ***Top of display***

Auto features on

(AUTO) If **any** of the automatic features are turned on, the “Auto” indication will appear here. (These include the automatic range, auto sensitivity, and auto zoom features.)

Auto range on (R)

The “range” is the maximum depth the unit is set to measure. When the auto range feature is on, the FishFinder chooses the correct range setting automatically.

Transducer frequency

The transducer can use two frequencies - 50 kHz for wide coverage, or 200 kHz for a detailed view. You can also set the unit to use both frequencies at the same time (“dual frequency”). (For more on this, see “Choosing the Frequency.”)

Auto sensitivity on (S)

The “sensitivity” controls the ability of the unit to tell the difference between echoes of different strengths. A higher sensitivity setting makes it easier to see smaller fish, but also may pick up background noise. When auto sensitivity is on, the FishFinder chooses the correct sensitivity setting automatically.

Auto zoom on (Z)

The “zoom” can be used to magnify the image from a small section of the water below the boat. (This is used with the Zoom display, which we will describe in a moment.) When the auto zoom feature is on, the FishFinder automatically moves the zoom window up or down to track the bottom.

Fish symbol on



When the FishFinder sees a fish, it can show this by displaying a fish symbol. When the fish symbol feature is turned off, the FishFinder indicates a fish as an arch-shaped line on the display. For more information, see the section on “Fish Indications.”

Boat symbol



This symbol is always turned on. It indicates that the new information appears at the right edge of the display, and the older information moves toward the left.

**Center of display**

**Water surface** This symbol (“0”) shows the depth indicated by the top of the display. Usually, this is the level of the surface of the water. (If the Zoom feature is turned on, this will show the depth of the top of the zoom area.) The depth is shown using the same units as the rest of the display. This could be feet (FT), fathoms (FA), or meters (M), depending on the setting you make in the System Setup display.

**Depth markers**

These markers show depths between the surface and the full depth range. In this example, the unit is set for a depth range of 100 feet. This means that each of the depth markers shows an interval of 20 feet.

**Speed**

This entry shows the speed of the boat through the water. From the System Setup display, you can turn this item off or change the units used for this display.

**Log/distance**

This shows how far the boat has traveled since the display was turned on, or since the log was last reset. From the System Setup display, you can turn this item off or change the units used for this display.

#### Water temperature

This entry shows the current water temperature at the surface of the water. (The reading for water temperature can be helpful for finding fish. A particular type of fish will often prefer water in a narrow temperature range.) From the System Setup display, you can turn this item off or change the units used for this display.

Fish symbol This indicates that the FishFinder sees a fish. Generally, the larger the fish symbol appears, the larger the fish. (The size of the fish symbol actually depends on a number of factors. See the section on "Fish Indications.")



If the fish is detected using the narrow 200 kHz beam, the display will show a filled-in symbol. If the fish is detected by the wide 50 kHz beam, the display will use a hollow symbol. (For more on this, see "Choosing the Frequency.")

Fish depth This indicates the depth of the fish shown by the fish symbol. This number will be shown using the same depth units (feet, fathoms, or meters) you have selected on the System Setup display. The fish depth indicator is turned off when the fish symbol function is off.

#### **Bottom of display**

##### Bottom indication

This shows the bottom of the lake or sea. You can compare this to the range depth shown in the lower right-hand corner. (In this example, the checkered pattern shows the unit is getting a strong echo return from the bottom. See the information on the White Line feature in the Setup Instructions.)

Range The "range" is the maximum depth the unit is set to measure. In this example, this is 100 feet. You can set the range manually, or the FishFinder can do it automatically.

Bottom depth This is the depth of the bottom shown on the display. You can select FT (feet), FA (fathoms), or M (meters) using the System Setup display. If the FishFinder can't tell how deep the water is, the last known depth flashes on the display. This will continue until the unit can see the bottom again.

### Buzzer symbol

This symbol shows whether any of the alarms will use the buzzer. There are three kinds of alarms: shallow, deep, and fish. If one of these alarms is set, it will always present a flashing symbol on the display. The Buzzer symbol shows whether the alarms will also use the buzzer.



If the Buzzer setting in the System Setup display is on (indicating that the buzzer is enabled for all of the alarms), this symbol will appear filled.



If the Buzzer setting is off (indicating that the buzzer is disabled for all of the alarms), this symbol will be open.

### Shallow alarm set

You can set an alarm to go off if the boat moves into water which is shallower than a certain depth. If you set this type of alarm, the "S" indicator will appear on the display. If the alarm is triggered, the "S" symbol will flash. If the buzzer has been turned on (in the System Setup display), the buzzer will also sound. To stop the buzzer, press the **CLEAR** button. The "S" symbol will continue to flash until you move into deeper water.

### Deep alarm set

You can set a different alarm to go off if the boat moves into water which is deeper than a certain depth. When this alarm is set, the "D" symbol will appear. If the alarm is triggered, the "D" symbol will flash. If the buzzer has been turned on (in the System Setup display), the buzzer will also sound. To stop the buzzer, press the **CLEAR** button. The "D" symbol will continue to flash until you move into shallower water.

### Fish alarm set

The FishFinder also has an alarm which will sound whenever it detects a fish. When this alarm is set, the fish symbol appears at the bottom of the display. If the alarm is triggered and the buzzer has been turned on (in the System Setup display), the buzzer will sound for a moment.

Before we explain the other pages, there are some general things you should know about the operation of the FishFinder.

## Choosing a Frequency

We said that the FishFinder uses sound waves to “see” through the water under the boat. The “frequency” is a measure of how fast the sound waves change or “vibrate.” The FishFinder uses sound waves with two different frequencies – 50 kHz and 200 kHz. Raymarine uses these two frequencies because each is better for a particular purpose:

### 50 kHz frequency

- Scans a wide area
- Penetrates water well, good for deep water

### 200 kHz frequency

- Scans a narrower area, but produces a more detailed view
- Good for seeing fish near the bottom or fish close together
- Better for use in very shallow water

### “Dual” frequency (both 50 kHz and 200 kHz at once)

- Has the advantages of both frequencies
- Good depth penetration
- Good detail in display
- Using the “Dual 50 kHz” setting, the display is produced using the signal from the 50 kHz beam, with additional information from the 200 kHz beam.
- Using the “Dual 200 kHz” setting, the display is produced using the signal from the 200 kHz beam, with additional information from the 50 kHz beam.

If you are using one of the dual frequency settings, you can get some useful information from the fish symbols. If the fish is spotted by the narrow 200 kHz beam, the fish symbol will be black or filled-in. If a fish is detected by the wide 50 kHz beam, the symbol will be hollow.

## Fish Indications

Even using advanced sonar technology, it is sometimes hard to detect a fish in the water. The body of a fish is just a little more dense than the surrounding water. There is really nothing very solid for the sound waves to bounce off of. The FishFinder L365 is very good at telling the difference between a fish and the surrounding water. In fact, Raymarine is the leader in this technology.

When the FishFinder finds a fish, it can be indicated by a fish symbol on the display. In general, a larger symbol means a larger fish. This rule is not always true, though. Let's say that there are two fish of the same size: one is close to the surface, and the other is near the bottom. The fish which is close to the surface will have a larger symbol. This is because the fish which is closer returns more of the sound waves back to the FishFinder.

Actually, the sound waves are usually reflected by the air sac near the center of the fish, and not by the body of the fish. The size of this air sac is different for different kinds of fish. This can also affect the size of the fish symbols on the display. A fish with a large air sac will produce a large fish symbol, while a fish with a small sac will produce a small symbol.

The symbol also indicates which of the two frequencies was used to locate the fish. If the fish was spotted by the wide 50 kHz beam, the symbol will appear to be hollow. If the fish was detected by the narrow 200 kHz beam, the symbol will be solid.

If the fish symbol feature is turned off, the FishFinder indicates fish in a different way. See Fig. 3-5. An arch-shaped mark on the display usually indicates a fish. Again, a larger arch usually indicates a larger fish. Several arches together show a school of fish.

The return from a fish will have a different appearance, depending on the frequency used. If a fish is spotted by the wide 50 kHz beam, the arch will be broad. When using the narrower 200 kHz beam, the same fish will produce a narrower arch.

The shape of the arch is also affected by the speed of the boat. If you are moving slowly, the arches tend to be longer. If the boat is moving more quickly, the arches are short and peaked. If the boat is moving very fast, a fish may be indicated by a single vertical line.



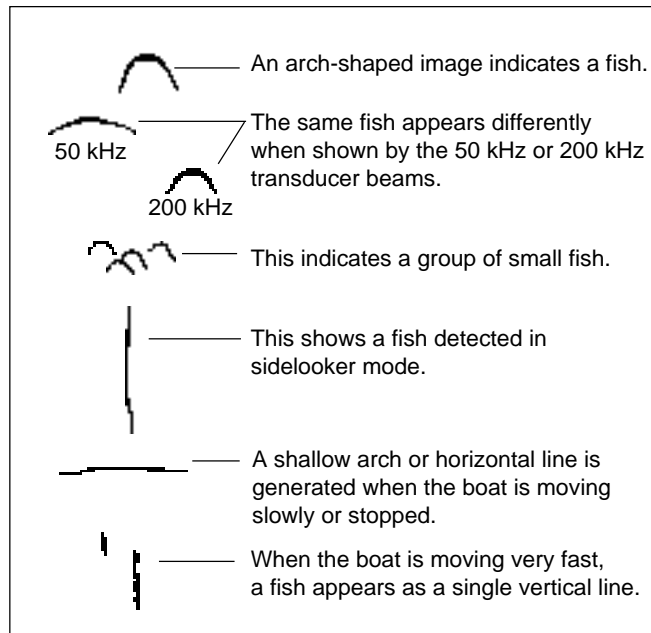

**Fig. 3-5**  
Fish  
Indications

## Bottom Indications

The bottom usually produces a strong echo, so it is easy for the FishFinder to see a lot of detail. The FishFinder can indicate many different kinds of bottom conditions. See Fig. 3-6. A hard bottom appears as a thin line. A softer bottom or a bottom covered with seaweed will produce a wide line, as the sound waves reflect from different layers of the bottom. An uneven bottom which is covered with rocks or coral produces a complex display like that shown in the last part of Fig. 3-6. The bottom image is irregular, with long "tails" pointing upward. A wreck produces a similar image.

When the White Line feature is turned on, the unit can display even more information about the bottom. In Fig. 3-4, the FishFinder is getting a good echo from the bottom, so the upper layer of the bottom is shown in a checkerboard pattern.

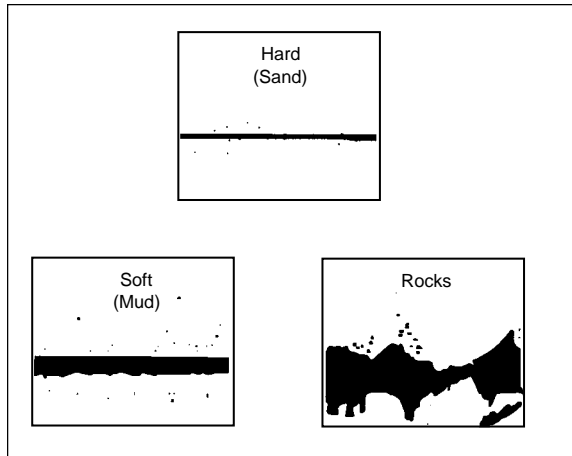

Fig. 3-6  
Bottom  
Conditions

Notice that the lower layer of the bottom is shown as a solid display. This indicates a weaker echo. Sometimes this means that the upper layer of the bottom is soft. Some of the sound waves may reach through this layer, and may be reflected by a more solid layer below. It is also possible that the sound waves are making **two** complete trips - hitting the bottom, bouncing off of the bottom of the boat, then reflecting off the bottom again. This can happen if the water is shallow, the bottom is hard, or the sensitivity is set to a high value.

Now, let's look at the other main operating displays. From the FishFinder display, press the > arrow of the Page control pad.

### Performance Modes

This unit has two "performance" modes which can be used to add to the standard FishFinder Page. These are the Zoom and the A-Scope Modes. Each presents the raw information from the transducers in a special way. To display one of these modes, press the Page key on the unit. See Fig. 3-3.

## Zoom Page

Press 

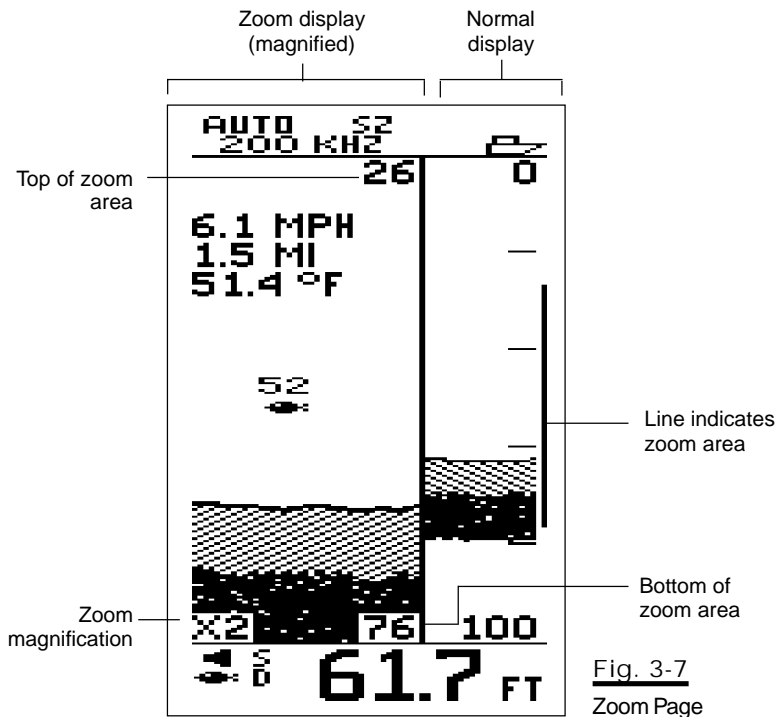

The Zoom page gives you a way of enlarging or magnifying a part of the display area. See Fig. 3-7. (The “zoomed” display is actually larger only in the vertical direction.) The right side of the display shows the same information as the FishFinder page. The left side shows the magnified view. In each case, the new information appears at the right edge of the display, and moves to the left.

Many of the items on the Zoom page are the same as those on the FishFinder page. There are a few new items.

#### Zoom magnification

This indicates the amount of “zoom” or magnification. You always set the amount of zoom manually, using one of the functions on the Setup display. You can choose an x2 view (double the normal display size), x4, x6 or x8 in the series of setup screens. See Section 4. You must also select the area or “window” of the water you want to zoom. See the next item.

#### Zoom area

When you turn on the zoom feature, it can only enlarge a part of the FishFinder display. You must decide which part you want to enlarge. As we said, the right side of the display shows the normal FishFinder display. The vertical line at the right edge of this display shows the area or “window” of the water being enlarged.

When the FishFinder is set for auto zoom, it will choose the zoom area automatically. The unit always chooses an area of the water which includes the bottom. The unit then moves this area up or down to keep the bottom in the picture. The auto zoom feature is great for bottom fishing.

You may also set the zoom area manually. In the series of setup screens, select manual zoom. (See Section 4.) Once you are back to the zoom display, you can move the zoom area up or down (using the  $\wedge$  and  $\vee$  arrows of the Page control pad) to enlarge any selected “window.”

To move to the next display, press the > arrow of the Page control pad.

## A-Scope (Bottom Coverage) Page

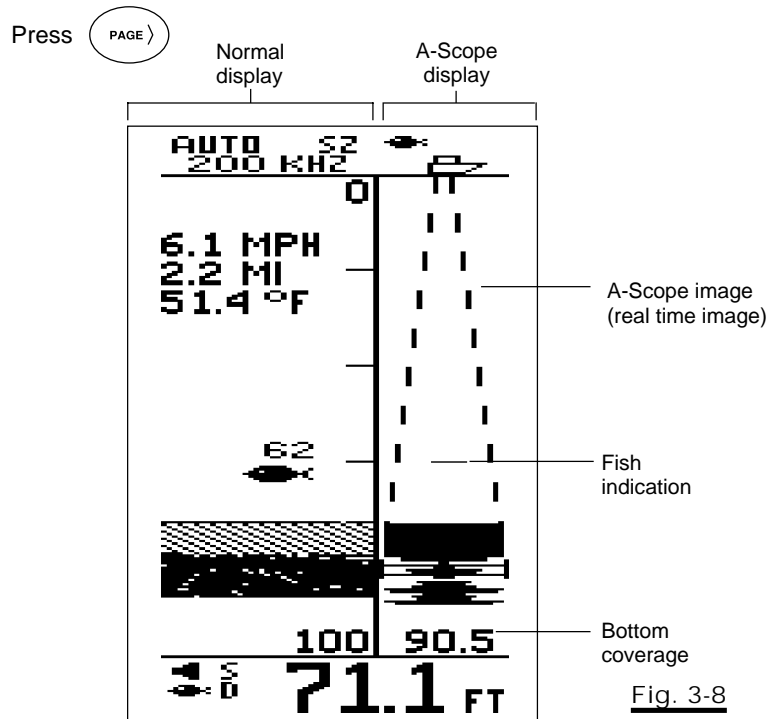

On the FishFinder display the bottom graph is “drawn” after the FishFinder receives several echoes. This has the effect of showing a record of the bottom contour. The A-scope displays raw sonar data directly from the transducer beam. This gives you a “real time” image of fish and bottom structure directly below the transducer. This function is very useful in showing the strength of the echo returned from a fish. Stronger fish echoes on the A-scope display will appear wider; weaker echoes appear as narrow bands closer to the horizontal center of the A-scope image.

The left section of the A-Scope display shows a section of the normal FishFinder display. All of the features are the same. The right section shows the A-Scope image.

#### A-Scope image

This shows the beam of sound waves extending down from the boat, and spreading as it moves through the water. Any fish or objects which are positioned under the boat will appear on the display. This is a "real time" display, so you can see the fish symbols moving as the fish swim under the boat.

#### Bottom coverage

This shows the diameter of the beam of sound waves where it meets the bottom. This dimension will be shown using the same units as the rest of the display – feet (FT), fathoms (FA), or meters (M). If the unit is set at 200kHz single frequency, the bottom coverage display will reflect the narrow (16°) beam of the 200kHz frequency setting. All other frequency selections (200kHz dual, 50kHz dual, and 50kHz single) use the wider (65°) beam for the bottom coverage display.

To move to the next page, press the > arrow of the Page control pad.

## Digital Page

Press 

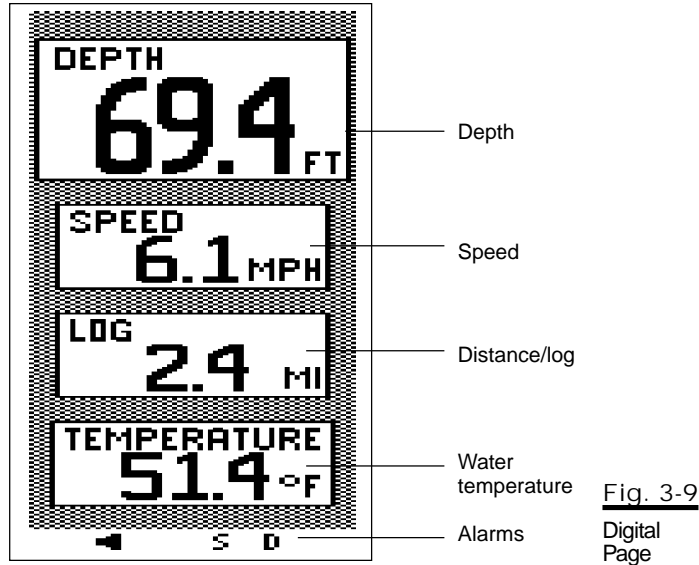

The Digital page presents some useful information in large numbers on the display. See Fig. 3-9. This display is useful when you are traveling, but not looking for fish or checking the appearance of the bottom. There are four main items:

- Depth        The Digital display reports the depth of the bottom.
- Speed        This is the speed of the boat through the water.
- Log           This entry shows the distance traveled, determined by the speed through the water. The L365 remembers this value after it is turned off. You may reset the log using the Setup Menu.
- Temperature   This is the current water temperature.
- Alarms       Notice that the alarm indications still appear at the bottom of the display.

To move to the next display, press the > arrow of the Page control pad.

## Sidelooker Page

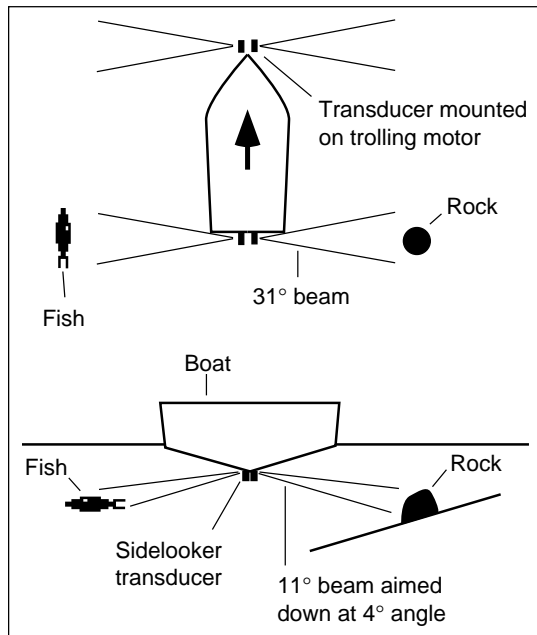

**Fig. 3-10**  
Sidelooker  
Feature

This feature will only work if an optional Sidelooker transducer has been installed, and if the Sidelooker feature has been turned on in the System Setup Menu. The Sidelooker feature is very helpful for certain kinds of fishing. It allows you to check for underwater structure along the sides of a stream or river, under the edge of a bank or pier, or into stumps or weed beds.

The optional Sidelooker transducer transmits two acoustic beams—one to the port side of the boat, and one to the starboard. These are displayed on the left and right halves of the Sidelooker Page. See Fig. 3-10.

Once the Sidelooker feature has been turned on, you can reach the Sidelooker page easily. Press the < or > buttons on the Page Control Pad until the Sidelooker Page appears. The unit will present a display similar to Fig. 3-11.



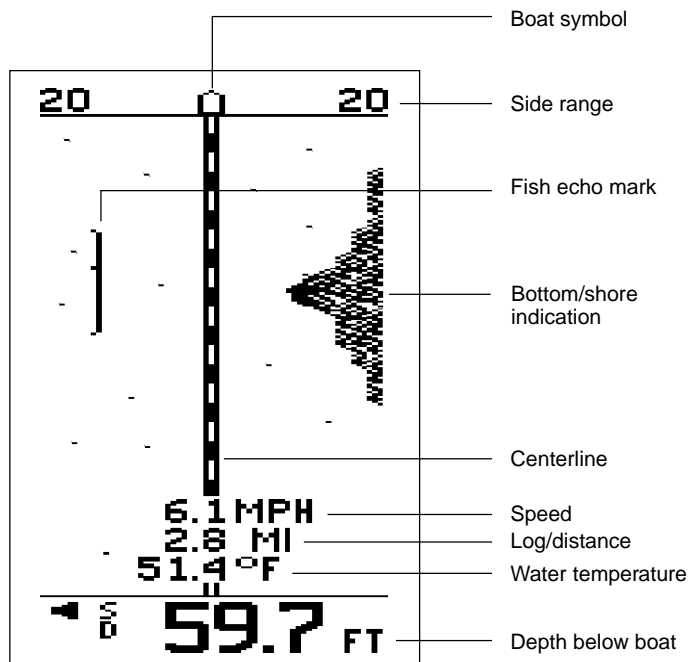

Fig. 3-11  
Sidelooper  
Page

The Sidelooper Page, like the FishFinder Page, displays a graph or chart. The scrolling vertical dashed line represents the centerline of the boat. As new Sidelooper echoes are received, the new information appears at the top of the display, and older information moves towards the bottom. There is no relationship between the chart speed of the FishFinder and the speed of the boat. (The speed at which the display moves is set by the entry for "chart speed" in the Setup Menu.)

When the Fish Symbol feature is turned off, any fish detected will appear as vertical marks. These may be slightly arched towards the center of the display. The unit can also be set to display fish symbols, but the normal fish marks are usually more helpful. The Sidelooper transducer transmits at the 200 kHz frequency. If the unit spots any fish while the Fish Symbol

feature is on, they will be indicated by solid fish symbols. (You can turn the Fish Symbol feature on or off from the System Setup Menu. See Section 4.)

Underwater objects such as submerged tree stumps or rocks can also be detected by the Sidelooker transducer. These objects usually appear as thicker vertical targets. The Sidelooker sounding beam is transmitted very close to the surface of the water. In rough or choppy water this turbulence may appear on the Sidelooker display as "noise" or "clutter." The Sidelooker will also display noise or clutter when your boat travels at high speeds or in very shallow water. For best results, use the Sidelooker at idle or slow trolling speeds.

Here are the special items on this display:

**Boat symbol** This is pointing forward on the screen to indicate that, on the Sidelooker Page, the view is from above, as seen from a bird's-eye. The boat symbol appears at the top center of the Sidelooker View.



**Dashed vertical line** The scrolling vertical line is drawn under, or behind, the boat symbol to indicate the division between the information produced by the left and the right sidelooker transducer elements.

**Side range** This is the maximum distance the unit will be able to see using the current range setting. Remember that the sound waves move out at a shallow angle, so this distance is measured **sideways**. See Fig. 3-10. The units used here are chosen using the entry for Depth Units in the System Setup Menu. If you have selected feet (FT) or fathoms (FA), the distance shown here will be measured in feet. If you have selected meters (M), the distance shown here will be in meters.

**Fish echo mark**  
A line or arch-shaped mark shows that the unit has detected a fish. In general, a larger mark indicates a larger fish. If the fish symbols are turned on, the unit will indicate fish using symbols instead. A number beside each symbol shows the distance from the boat to the fish. Remember that this distance is measured **sideways**. See Fig. 3-10.

The units used here are chosen using the entry for Depth Units in the System Setup Menu. If you have selected feet (FT) or fathoms (FA), the distance shown here will be measured in feet. If you have selected meters (M), the distance shown here will be in meters.

**Bottom/Shore**

**Indication** This indicates the area where the transducer beam is starting to see the bottom, shore, or some other object. Again, remember that the beam is looking sideways, so this could really represent the bank of a stream or structure under a dock or pier.

**Depth** This is the depth directly below the boat. Even when the Sidelooker feature is turned on, the downward-looking transducer is still used to measure the depth.

The Sidelooker feature has settings for Range and Sensitivity which are separate from the Range and Sensitivity settings used for the standard FishFinder Page. See Section 4 for details.

## 4 - Setup Instructions

### The Setup Menu

Press the Setup button to enter the Setup Menu. To move from one display to another, press the  $\nabla$  and  $\Lambda$  arrows of the Page control pad. To return to the normal display, press **CLEAR**. See Fig. 4-1. This means that you can reach these displays quickly, make a change, then return to the normal display quickly.

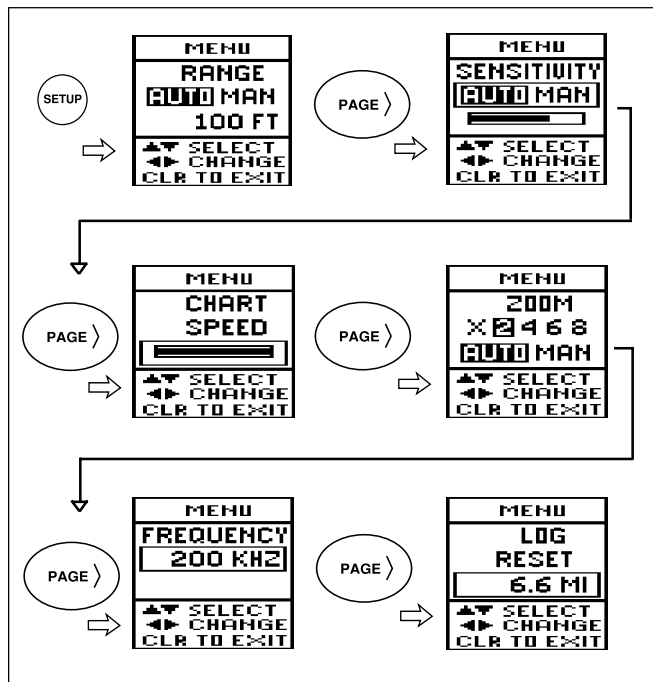

Fig. 4-1  
Moving  
Through  
the Setup  
Menu

## Range Setting

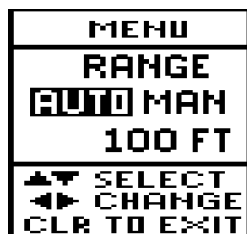

Fig. 4-2  
Range  
Settings

If you press **SETUP** once, the first menu item allows you to set the range. See Fig. 4-2. The range sets the maximum depth the unit will be able to see. Use the < and > arrows of the Page control pad to select Auto or Manual range. (If you press **SETUP** while you are looking at the Sidelooker display, the unit will allow you to set the range for the Sidelooker feature. See the end of this section.)

**Auto range** The FishFinder can be set to select the range by itself, automatically. The unit chooses the shallowest range which will still include the bottom in the display. If the bottom rises or falls, the FishFinder will adjust the range to keep the bottom in the display.

**Manual range** You can also set the range yourself. (However, if the bottom rises or falls, the FishFinder will not adjust for this.) As soon as you select Manual, the cursor will jump down a line so you can choose the range you want. Use the < and > arrows of the Page control pad to make a selection. Here are the choices:

### Possible Range Settings (Auto or Manual)

*In feet:* 5, 10, 20, 30, 50, 80, 100, 150, 250, 400, 600, 1000, 1500, 2000

*In fathoms:* 2, 3, 5, 10, 15, 20, 25, 30, 50, 80, 100, 150, 200, 350

*In meters:* 2, 5, 10, 15, 20, 25, 30, 50, 80, 120, 200, 300, 500, 650

*If you are done with your setup changes, press the **CLEAR** button to go back to the normal display. To select the next menu item, press the V arrow of the Page control pad.*

## Sensitivity Setting



Fig. 4-3  
Sensitivity  
Setting

The sensitivity adjusts the ability of the unit to tell the differences between echoes of different strengths. In general, the sensitivity should be as high as possible, to detect the fish and show the detail on the bottom. However, if the sensitivity is too high, the unit will begin to see bubbles in the water, debris, and other “background noise.” Use a higher sensitivity setting for deeper water, and a lower setting for shallower water.

If you adjust the sensitivity while you are looking at the Sidelooper display, this will affect the sensitivity for the Sidelooper feature only.

From the menu item for the range setting, press the V arrow of the Page control pad. The next menu item will allow you to set the sensitivity. See Fig. 4-3. Use the < and > arrows of the Page control pad to select Auto or Manual sensitivity.

### Auto sensitivity

The FishFinder can be set to select the sensitivity by itself, automatically. The unit chooses the sensitivity setting which will detect fish, but will also show a minimum of background noise. If the amount of background noise changes (due to changing depth or water conditions), the FishFinder will change the sensitivity to adjust. (You can adjust the sensitivity of the unit while it is using Auto sensitivity. Once Auto sensitivity is selected, use the V arrow of the Page control pad to go to the next line,

then use the < and > arrows of the Page control pad to fine-tune the setting. When the FishFinder is turned off, then on again, the Auto sensitivity setting returns to the normal default setting.)

#### Manual sensitivity

You can also set the sensitivity manually. If the amount of background noise changes, the FishFinder will not adjust for this. If you choose Manual sensitivity, press the V arrow of the Page control pad to go to the next line. Use the < and > arrows of the Page control pad to move the dark bar on the display. Making the bar longer increases the sensitivity.

*If you are done with your setup changes, press the CLEAR button to go back to the normal display. To select the next menu item, press the V arrow of the Page control pad.*

## Chart Speed Setting

Most of the displays on the FishFinder show a record of the signals the unit has received. The new information appears at the right (or top) edge of the display. The older information moves toward the left (or bottom) of the display. The chart speed adjustment sets the speed at which the display moves. (Notice that the scrolling speed of the display is not related to the speed of the boat over the bottom. The speed of the display is controlled **only** by the chart speed setting.)

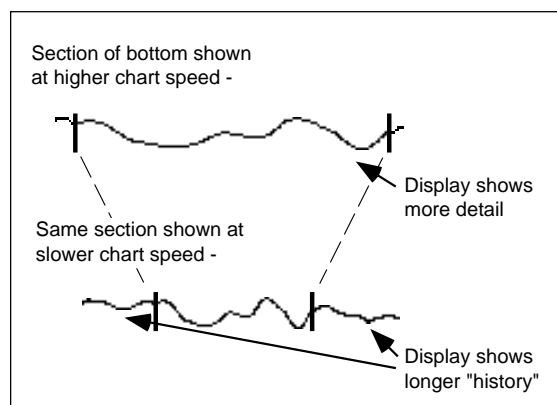

**Fig. 4-4**  
Changing the Chart Speed Setting

Figure 4-4 shows how the chart speed setting affects the display. In both cases, the unit is showing the same section of the bottom. Using a faster chart speed, the display has more space on the display to show this section, so it can include more detail. Using a slower chart speed, this same information is displayed in a smaller horizontal space.

A faster chart speed setting shows more detail on the bottom. You will probably want to use a faster setting when you are looking for fish.

A slower chart speed setting shows a longer record of the bottom you pass over. Any fish detected will stay on the display longer.

From the display for the sensitivity setting, press the V arrow of the Page control pad. The next menu item will allow you to set the chart speed. See Fig. 4-5.

**Chart speed** This adjusts the speed at which the information moves across the display. Use the < and > arrows of the Page control pad to change the chart speed. Making the bar longer increases the chart speed. If you move the bar all of the way to the left, the FishFinder will “freeze” and hold the current display. (The depth indicator will continue to update.)

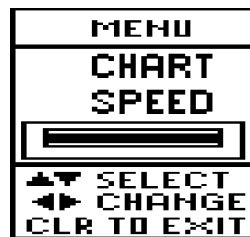

Fig.45  
Chart Speed  
Setting

*If you are done with your setup changes, press the CLEAR button to go back to the normal display. To select the next menu item, press the V arrow of the Page control pad.*



## Zoom Setting



Fig. 4-6  
Zoom Settings

The “Zoom” feature allows you to enlarge or magnify a section of the normal display. This lets you see a “window” of the echosounder view in detail. The Zoom window may be set for four different levels of magnification. You can choose settings for x2, x4, x6 or x8 magnification.

### Zoom

**magnification** Press the > arrow of the Page control pad to select x2, x4, x6, or x8 Zoom magnification. At this point you may press **CLEAR** to return to the normal display or you may press the V arrow of the Page control pad to select Auto or Manual Zoom.

**Auto zoom** Once you have set the zoom magnification, you may select either auto or manual zoom control. Select auto zoom, and the FishFinder will automatically control the position of the Zoom window. The auto zoom control constantly tracks the bottom contour, and adjusts the position of the Zoom window accordingly with changes in depth. This feature is particularly useful when fishing for species of fish which stay close to the bottom. Use the < and > arrows of the Page control pad to select auto zoom. Press the V arrow of the Page control pad to leave this display, and store the auto zoom setting.

**Manual zoom** If you select manual zoom, you can choose the position of the zoom area yourself. Use the < and > arrows of the Page control pad to select manual zoom.

Once you make this choice, you can set the zoom area yourself. You do this after you exit the Zoom Settings

display, and you are looking at the Zoom display itself. You can manually move the Zoom area up or down by pressing the  $\wedge$  and  $\vee$  arrows of the Page control page. The location of the zoom area is shown by the dark vertical line at the very right-hand edge of the display.

*If you are done with your setup changes, press the **CLEAR** button to go back to the normal display. To select the next menu item, press the  $\vee$  arrow of the Page control pad.*

## Frequency Setting



Fig. 4-7  
Frequency  
Setting

“Frequency” is a measure of how fast the sound waves change or “vibrate.” This unit uses sound waves with two different frequencies – 50 kHz and 200 kHz. For an explanation on the uses of these two frequencies, see the section on “Choosing a Frequency.”

From the area of the display for the zoom settings, press the  $\vee$  arrow of the Page control pad. The next menu item will allow you to make the frequency setting. See Fig. 4-7.

**Frequency** Use the  $<$  and  $>$  arrows of the Page control pad to make your choice.

You have four choices here:

- 200 kHz, single frequency – The unit will use the narrow 200 kHz beam. The fish symbols will be solid.
- 50 kHz, single frequency – The unit will use the wider 50 kHz beam. The fish symbols will be hollow.
- 200 kHz, dual frequency – The unit will use both frequencies, but the image on the display will be generated using the information from the narrow 200 kHz beam.

- 50 kHz dual frequency – The unit will use both frequencies, but the image on the display will be generated using the information from the wider 50 kHz beam.

If you are using one of the dual frequency choices, some of the fish may be revealed by one beam, but not the other. If a fish is detected by the narrow 200 kHz beam, the symbol for that fish will appear solid. Any fish which are detected by the wider 50 kHz beam will have fish symbols which are hollow.

*If you are done with your setup changes, press the **CLEAR** button to go back to the normal display. To select the next menu item, press the V arrow of the control pad.*

## Resetting the Log

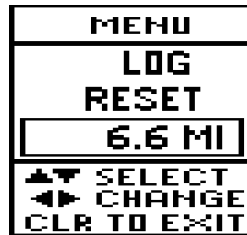

Fig. 4-8  
Resetting  
the Log

The “log” measures how far the boat has traveled through the water. The log records the distance traveled since it was last reset. You can reset the log at any time using the display shown in Fig. 4-8.

### Distance reading

The number inside the box shows the distance reading now being displayed by the unit. To reset the log to zero, press either the < or the > arrows of the Page control pad.

*If you are done with your setup changes, press the **CLEAR** button to go back to the normal display. To go back to the menu item for Range Setting, press the V arrow of the Page control pad.*

## System Setup Display



Fig. 4-9  
Reaching the  
System Setup  
Display

You can reach the System Setup display at any time by pressing the Setup button twice. This means that you can reach this display, make a change, then return to the normal display quickly. See Fig. 4-9. Figure 4-10 shows the items in this display.

SYSTEM SETUP	
SIMULATOR	ON
SYMBOL	ON
W. LINE	ON
SIDELOOK	ON
SPEED CAL	100
TEMP CAL	0.0
ALARMS	
SHALLOW	OFF
DEEP	OFF
FISH	OFF
BUZZER	ON
UNITS	
DEPTH	FT
SPEED	MPH
TEMP	°F
DATA	
SPEED	ON
LOG	ON
TEMP	ON

Fig. 4-10  
System Setup  
Display

80.4 FT

To change one of the items, use the  $\wedge$  and  $\vee$  arrows of the Page control pad to move up or down in the display. This will highlight an area on the display where the unit is ready to make a change. (This is like the "cursor" on a computer.)

Once you have moved to the correct line, press the  $<$  or  $>$  arrows of the Page control pad to change the entry. When you leave the display, the unit will store any changes you have made.

**Simulator** This unit has a built-in simulator. When the simulator is enabled, it presents a realistic display. You can use this display to learn about the features of the unit without operating your boat. The information on this display is generated by the unit itself, and does not come from a transducer. When this mode is turned on, you will see the word "Simulation" flashing on the display.

**Fish symbol** When the unit detects a fish, it can show this using a fish symbol. A number above the symbol shows the depth of the fish. The size of the symbol is related to the size of the fish. In general, the larger the symbol, the larger the fish. (For more information, see the section on "Fish Indications.")

When the fish symbol is turned off, the unit indicates a fish by showing an arch-shaped line. See Fig. 3-5. This kind of display does not include the depth readings for the fish.

**White line** This feature controls the way the unit displays strong and weak echoes. When the white line feature is turned off, all of the echoes are displayed in black. When the feature is turned on, strong echoes are displayed using a crosshatch (or "checkerboard") pattern. A weaker return is shown using a solid area of black or gray.

This feature helps to show the difference between the strong echo from the bottom and the weaker echoes from fish or weeds near the bottom.

**Sidelooker** This item is used with the optional "Sidelooker" transducer. This type of transducer sends sound waves out to the sides of the boat. See Fig. 3-10. If you have installed this

transducer, use this line of the display to turn on the Sidelooper mode.

- Speed Cal** This unit can detect and display the speed of the boat through the water. It also uses the speed information to calculate the distance traveled (the "log"). The item for Speed Cal allows you to adjust the speed reading to make it match your actual speed through the water. It presents a reading in percentage points. A reading of 100% means the speed readings from the factory default calibration are accurate, and the unit does not need any correction. If the unit says that you are moving faster than you really are, you can adjust the Speed Cal figure to a smaller number. If the unit says that you are moving slower than your actual speed, use a larger number for Speed Cal. The setting can range between 75 and 125. Use the < and > controls to change the value. For more information, see the section on "Calibrating the Sensors."
- Temp Cal** This unit can display the water temperature. You may want to fine-tune the signal from the transducer to get an accurate display. The displayed number indicates an offset added to the measured temperature. (This offset will be measured in °F or °C, depending on the setting used for Temp Units.) For example, if the temperature reading on the FishFinder display tends to read 2°F too high, you can correct for this by setting Temp Cal to -2.0°. The setting can range between -9.9° and +9.9°. Use the < and > controls to change the value.
- Shallow Alarm** You can set an alarm to trigger whenever the boat moves into water which is shallower than a limit you set. Use the  $\wedge$  and  $\vee$  controls to move to the line for Shallow Alarm and use the > arrow of the Page control pad to turn this item on. Once you do this, the display will ask which depth you want to use as a limit. Use the < and > controls to set the limit you want. To turn this feature off, press the < control until the display indicates zero feet, fathoms or meters.

When the shallow alarm is set, the letter "S" will appear in the lower left-hand corner of the normal displays. If you move into shallow water and trigger the alarm, the letter "S" will begin to flash, and the buzzer will sound. Press the **CLEAR** button to silence the buzzer. The letter "S" will continue to flash until you move into deeper water.

**Deep Alarm** An alarm can be set to trigger whenever the boat moves into water which is deeper than a preset limit. Use the  $\wedge$  and  $\vee$  controls to move to the line for Deep Alarm and use the  $>$  control to turn this item on. Once you do this, the display will ask which depth you want to use as a limit. Use the  $<$  and  $>$  controls to set the limit you want. To turn this feature off, press the  $<$  control until the display indicates zero feet, fathoms or meters.

When the deep alarm is set, the letter "D" will appear in the lower left-hand corner of the normal displays. If you move into deep water and trigger the alarm, the letter "D" will begin to flash, and the buzzer will sound. Press the **CLEAR** button to silence the buzzer. The letter "D" will continue to flash until you move into shallower water.

Note: You may want to use both the Shallow Alarm and Deep Alarm features when you are anchored. Set the limits just a bit to either side of your anchor depth. When set this way, the unit will trigger an alarm if the anchor drags and the boat moves into shallower or deeper water.

**Fish Alarm** This unit has an alarm which will trigger when the unit detects a fish. Use the  $<$  and  $>$  controls to turn this item on or off. The fish alarm feature will work even if the fish symbols are turned off.

When the fish alarm is set, the fish symbol will appear in the lower left-hand corner of the normal displays.

**Buzzer** A buzzer can be set to sound when any of the alarm conditions occurs (shallow, deep, or fish alarm). For the shallow or deep alarms, the "S" or "D" symbol at the bottom of the screen flashes. By pressing the **CLEAR** button, you can

silence the buzzer for the **current alarm condition**. The “S” or “D” symbol will continue to flash as long as the alarm condition is still present.

If the alarm condition occurs again, the buzzer will sound again. (For example, this would happen if, after a shallow alarm you move into deep water, then return to shallow water.) You can silence the buzzer again by pressing the **CLEAR** button.

The Buzzer entry in the System Setup display allows you to permanently silence the buzzer for all of the alarms. Use the < and > controls to turn this item on or off. The buzzer symbol at the bottom of the screen will appear hollow.

Once you do this, if a shallow alarm or deep alarm occurs, the “S” or “D” symbol will flash, but the buzzer will not sound. You can enable the buzzer again at any time by calling up the System Setup display, going to the line for Buzzer, and turning the item on again. The buzzer symbol at the bottom of the screen will appear solid.

Each time you press one of the buttons on the display panel, the buzzer will “beep.” The buzzer will continue to do this, regardless of the setting of the Buzzer option in the System Setup display.

**Depth Units** This item sets the units used by the depth display. You can choose feet (FT), fathoms (FA), or meters (M). Use the < and > controls to make your choice.

**Speed Units** This item sets the units used by the speed display. The same units are used for the distance (“log”) display. There are three choices:

Code	Units used for speed	Units used by log
MPH	Miles per hour	Statute miles
KTS	Knots	Nautical miles
KPH	Kilometers per hour	Kilometers



- Temp Units** This item sets the units used by the temperature display. You can choose Fahrenheit degrees (°F) or Celsius degrees (°C). Use the < and > controls to make your choice.
- Speed** A speed indication appears on all of the normal displays. If you do not want to see this item, you can turn it off using this line of the System Setup display. Use the < and > controls to make your choice. (The Speed item will still appear on the Digital display. See Fig. 3-9.)
- Log** On the normal displays, an entry for “log” indicates the distance traveled. You can turn off this item using this line of the System Setup display. Use the < and > controls to make your choice. (The Log entry will still appear on the Digital display.) Notice that the units used by the log are set by changing the entry for Speed Units.
- Temp** An entry for temperature may appear on all of the displays. You can turn this item off using this line of the System Setup display. Use the < and > controls to make your choice. (This item will still appear on the Digital display.)

If you are done with your setup changes, press the **CLEAR** button to go back to the normal display.

## Setup Instructions for Sidelooker

Some installations include the optional Sidelooker transducer. We described the operation of this transducer in Section 3. If your boat has this transducer, there are some extra setup steps required.

The Sidelooker feature must be turned on using the System Setup display. Press the **SETUP** button twice to reach this display. Press the **V** arrow of the Page control pad three times to reach the line labeled “Sidelook.” Press the **>** arrow of the control to turn the feature on.

The System Setup display includes a line which allows you to set the Chart Speed. This setting for Chart Speed affects the standard displays, and also the Sidelooker display.

Once the settings on the System Setup display are correct, press the **CLEAR** button to go back to the normal display.

Next, press the > arrow of the Page control pad until you see the Sidelooker page.

The next job is to set up the range, sensitivity, and chart speed for the Sidelooker feature. While the unit is displaying the Sidelooker page, press the **SETUP** button once. The setup menu for the Sidelooker range will appear.

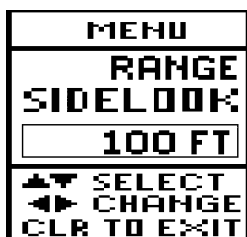

Fig. 4-11  
Sidelooker  
Range Settings

Once the Sidelooker feature is turned on, the FishFinder uses **two** range settings: one for the standard displays, and a second for just the Sidelooker feature. The menu item shown here sets the range for **just** the Sidelooker. (This will not change the range setting for the other display pages.)

The range for the Sidelooker uses the Manual setting only. Select the range you want to use. The maximum range of the Sidelooker transducer is 150 ft (or 50 meters).

Press the V arrow of the Page control pad to move to the next menu item.



Fig.4-12  
Sidelooker  
Sensitivity Settings

This menu item allows you to set the sensitivity for the Sidelooker feature only. (This will not change the sensitivity setting for the other display pages.) Choose Auto or Manual sensitivity. If you choose Manual sensitivity, use the < and > arrows of the Page control pad to adjust the sensitivity.

At this point, you can press the **CLEAR** button to go back to the Sidelooker display.

If you press the V arrow of the Page control pad, the unit will move to the remaining menu items – zoom, frequency, and log reset. The zoom and frequency settings are for the normal displays – they will not change the Sidelooker feature. The log reset menu will operate normally.

## Resetting the Unit to Factory Defaults

It is easy to reset all of the settings on the FishFinder at the same time. When the unit is off, press the **PWR** and **CLEAR** buttons at the same time. (Release the buttons as soon as the FishFinder begins to operate.) All of the settings will be reset to the values listed below, and the trip log will be reset to zero.

## Default Settings

When the FishFinder is new, it uses a number of preset “default” settings. Here is a list:

Function	Default - US model	Default - Europe model
Range	Auto	Auto
Sensitivity	Auto	Auto
Chart Speed	3 (fast)	3 (fast)
Zoom	Auto/x4	Auto/x4
Frequency	Dual 200 kHz	Dual 200 kHz
Simulator	Off	Off
Fish symbols	On	On
White line	On	On
Sidelooker	Off	Off
Depth units	FT (feet)	M (meters)
Temperature unit	°F (Fahrenheit)	°C (Celsius)
Speed units	MPH (miles per hour)	KPH (kilometers per hour)
Shallow alarm	Off	Off
Fish alarm	Off	Off
Deep alarm	Off	Off
Buzzer	On	On
Speed/temp/log	On	On

---

## 5 - Maintenance and Troubleshooting

---

Periodically check the display unit, cable, and transducer. Be sure all components are free of corrosion and are securely mounted. Check all cables for signs of chafing or abrasion. Be sure all of the connections to the boat's DC power and ground system are clean and tight.

### Cleaning Instructions

Always keep the display unit clean. Use a soft, clean cloth to wipe off the display panel. Do not use abrasive cleansers, chemical cleaners or solvents. Use a glass cleaner or a suitable general-purpose detergent.

If you operate your boat in salt water, you will have to protect the hull with antifouling paint. Use caution when sanding or cleaning the outside of the hull near the transducer. Harsh cleaning solvents such as acetone may damage the transducer.

Sea growth can collect quickly on the bottom of the transducer. This can reduce the performance in just a few weeks. To prevent this, coat the bottom of the transducer with a thin layer of paint. Use only a water-based antifouling paint, or a water-based paint specifically designed for transducers. Apply it with a brush.

If your transducer becomes fouled or stops working because of sand or sea growth, use a stiff brush to clean it. You may sand the surface with a fine-grit wet or dry sandpaper (#320 grade or finer), but this will affect the performance of the unit when the boat is moving at higher speeds.

The paddle wheel mechanism may become jammed by dirt or grit. Work this out of the mechanism, then clean the unit with soap and water or alcohol.

### Troubleshooting Suggestions

If the unit is not working correctly, there may be a simple cause. Before you call for service help, please check these points:

**The FishFinder display unit will not turn on –**

1. The unit may actually be operating, but the contrast may have been set to the "full light" or "full dark" setting. Turn on the unit by pressing the **PWR** and **CLEAR** buttons at the same time to change all settings to

- the factory defaults. See the default settings on page 63.
2. If the power wiring includes a fuse, it may be blown. Also check the circuit breaker or main battery switch.
  3. You may have reversed the power connections. Follow the DC power lines all the way back to the battery. The red wire should connect to the positive terminal (+) on the battery or power source, and the black wire should connect to the negative terminal (-) (also called "ground" or "earth"). If the polarity is not correct, reconnect the leads properly and check again.
  4. The battery or DC power source may not be producing the correct voltage. The FishFinder needs at least 11 volts to operate. If the voltage is lower, check for loose or corroded connections, or a problem with the power source.

**The display unit "freezes" (temporarily or permanently) –**

1. Check that the display has not been stopped using the Chart Speed setting. (If the adjustment bar is moved all of the way to the left, the display will freeze.)
2. A source of electrical "noise" may be interfering with the unit's operation. Both the transducer cable and the power cable for the FishFinder should be routed as far as possible from all other wiring on the boat.  
To locate the source of the noise, turn on the FishFinder. Next, turn on each electrical device on the boat, but just supply power to one device at a time. This may reveal the cause of the problem. Move the FishFinder, the other unit, or the wiring. A movement of just a few inches can make a big difference. If it is necessary to cross any wires, make the crossing at a right angle.  
Start the motor in neutral and increase the RPM speed. This can reveal a problem with the wiring for the boat's ignition, alternator, or tachometer. It may help to use resistor-type spark plugs or spark plug cables on the boat's motor. You can also try a noise-suppression filter on the alternator.
3. One of the wiring connections may be loose. All of the connections should be clean, tight, and insulated. Soldering is the best way of making these connections. Protect each connection with a piece of shrink-wrap tubing.

4. The transducer cable may be damaged. Check for any point where the wiring may be pinched or bent. Look for signs that water has gotten into the cable. If the transducer cable is damaged, the transducer and cable should be replaced as a unit. Contact Raymarine for instructions.

**The display unit does not see the bottom or fish –**

1. Be sure the display unit is not using the Simulation mode. (If this is the case, the word "Simulation" will flash on the display.)
2. On a unit with the transom-mount transducer, the transducer may have "kicked up" because it hit an obstruction. See Fig. 2-4. Move the transducer down into the working position.
3. The unit may be set for Manual sensitivity, and be using a very low sensitivity setting. To reset all of the values to the factory defaults, turn on the unit by pressing the **PWR** and **CLEAR** buttons at the same time. See the default settings on page 63.
4. The transducer may not be vertical. Be sure that the transducer is aiming straight down, or within 10° of vertical.
5. If the transducer is an in-hull type, be sure that it is installed correctly. The transducer should be "looking" through just one layer of fiber-glass hull material, no more than 1" (25 mm) thick. The transducer should be firmly attached to the hull using the correct type of adhesive/sealant.
6. The face of the transducer may be covered or fouled. Use a stiff brush to clean it. You may also sand the surface with a fine-grit wet or dry sandpaper (#320 grade or finer), but this will affect the performance of the unit when the boat is moving at higher speeds.
7. If the FishFinder is using the Auto Sensitivity setting, it may be reacting to an increase in electrical "noise." As the level of noise increases, the sensitivity automatically adjusts, and the unit can lose its ability to see the bottom or fish. Check for problems with the wiring as described in the section on "Display unit freezes."
8. The voltage from the power source may be low. This affects the transmitting power of the FishFinder. Check the connections as described in the section on "The display unit freezes."

**The FishFinder does not display fish arches –**

1. Be sure the Fish Symbol feature is turned off. See the instructions for the System Setup display.
2. The FishFinder will not display arches unless the boat is moving. If the boat is stopped, fish will appear on the display as straight lines.
3. The transducer may not be aimed straight down. In order to display complete arches, the transducer must be vertical.
4. The sensitivity setting may not be high enough. Go to the Setup Menu, choose Manual Sensitivity, and increase the sensitivity.

**The display disappears or is unreliable when the boat is moving at high speeds –**

1. Increased turbulence around the transducer may be “confusing” the unit. Move the transducer to a location where there is less turbulence when the boat is moving.
2. If the FishFinder is using the Auto Sensitivity setting, it may be reacting to an increase in electrical “noise.” As the level of noise increases, the sensitivity automatically adjusts, and the unit can lose its ability to see the bottom or fish. Check for problems with the wiring as described in the section on “The display unit freezes.”

**The display unit shows lots of background “noise” –**

1. The unit may be set to use the manual sensitivity adjustment, and the sensitivity may be set too high. See the information on “Setup Instructions.”
2. The transducer may be mounted incorrectly, or may be fouled. Check the mounting as described in Section 2. Clean the transducer as described earlier in this section.

**The depth setting flashes often –**

Note: Normally, this indicates that the bottom has moved out of range.

1. The transducer may not be installed correctly, or the signal may not be reaching the display unit. Recheck the instructions in “Mounting the Transducer” in Section 2. Check the transducer cable for signs of damage. If the cable is damaged, the transducer and cable should be replaced as a unit.
2. The voltage reaching the unit may be low, and this may be affecting the transmitting power. Check for problems with the wiring as described in the section on “The display unit freezes.”



**The speed or log readings are wrong –**

1. The paddle wheel on the transducer may be fouled. Clean the parts as described in the section on “Cleaning Instructions.”
2. Check the speed calibration. Use the item for “Speed Cal” on the System Setup display. See the instructions in Section 2.

## Servicing a Thru-Hull Transducer

If your boat has a thru-hull transducer, you can service it without removing the boat from the water. The sensor(s) are mounted in a cylindrical plug in the center of the transducer assembly. If necessary, you can remove this plug by working from the inside of the boat. The transducer housing includes a check valve to minimize the water intrusion when removing the insert. A small amount of water will enter the boat. This is normal. Immediately after removing the speed insert, place the dummy insert in the transducer housing. Do not leave the transducer without the speed or dummy insert in place.

## How to Contact Raymarine

***For marine product and services information***

Visit the Raymarine World Wide Web site for the latest information on the newest Raymarine electronic equipment and systems:

[www.raymarine.com](http://www.raymarine.com)

***For accessories and parts***

Many Raymarine accessory items and parts can be obtained directly from your authorized Raymarine dealer. However, if you are in need of an item not available from the retailer, please contact Raymarine Customer Service at 1-800-539-5539, extension 2333 or (603) 881-5200, extension 2333. Customer Service is available Monday through Friday, 8:15 a.m. to 5:00 p.m. Eastern Standard Time or Eastern Daylight Savings Time.

If placing an order, please have the Raymarine item or part number ready when calling. (See the Optional Accessory List on page 2 in this manual.) If you are not sure which item is appropriate for your unit, you should first contact the Technical Support Department at 1-800-539-5539, extension 2444 to verify your requirements.

***For technical support***

Please call 1-800-539-5539, extension 2444 or (603) 881-5200, extension 2444. The Raymarine Fax number is 1-603-634-4756.

Our Technical Support Specialists are available to answer questions about installing, operating, and troubleshooting all Raymarine products. Questions may be addressed directly to our Technical Support Department via the Internet at:

techsupport@raymarine.com

***For product repair service***

In the unlikely event your Raymarine unit should develop a problem, please contact your authorized Raymarine dealer for assistance. The dealer is best equipped to handle your service requirements, and can offer timesaving help in getting the equipment back into normal operation.

In the event that repairs cannot be obtained conveniently, product service may also be obtained by returning the unit to Raymarine's Product Repair Center using the prepaid shipping tag supplied with the unit. Return the unit to:

Raymarine Product Repair Center  
22 Cotton Road, Unit D  
Nashua, NH 03063-4219-USA

The Product Repair Center is open Monday through Friday, 8:15 a.m. to 5:00 p.m. Eastern Standard Time or Eastern Daylight Savings Time. All products returned to the Repair Center are registered when they arrive. A confirmation letter will be sent to you acknowledging the repair status and listing the product's reference number. Should you wish to inquire about the repair status of your unit, contact the Product Repair Center at 1-800-539-5539, extension 2118. Please have the product reference number or unit serial number ready when you call. We will do everything possible to repair the unit and return it to you as quickly as possible.

### **Raymarine in Europe**

In Europe, support, service, and accessories are available from:

Raymarine Limited  
Anchorage Park, Portsmouth  
Hampshire PO3, 5TD, England  
Tel: +44 (0) 23 9269 3611  
Fax: +44 (0) 23 9269 4642

Technical support is available via the Internet. Questions may be sent directly to this address:

[techsupport@raymarine.com](mailto:techsupport@raymarine.com)

### **Prepaid Return Service**

The return label included with your Raymarine unit provides **free ground shipping** to our Product Repair Center for all warranty repairs. This service is available only to customers within the continental United States.

To return your Raymarine unit for warranty repair, please follow these steps:

1. Fill out the service information card completely.
2. Pack your FishFinder and the service information card in a suitable shipping container. It is best to use the original carton, if it is available.
3. Fill in your **name, address and zip code**.
4. Attach the label to the outside of the shipping carton. Be sure to retain the shipping receipt.
5. Give the package to your nearest shipping outlet, or directly to the driver. Your Raymarine unit will be shipped directly to our Product Repair Center.



---

## 6 - Specifications

---

### General Information

Display panel	FSTN high-contrast LCD
Panel dimensions	3.6" H (61 mm) x 2.4" W (91 mm)
No. of dots	240 x 64
LCD contrast	Adjustable, with temperature compensation
Backlight	LCD panel, on/off
Operating modes	FishFinder mode (standard mode)
	Zoom mode
	A-Scope mode
	Digital mode
	Sidelooker mode
Keys	Silicon rubber
Memory backup	Non-volatile, no battery required
Power source	11.0 to 16.1 V DC
Power consumption	backlight off - approx. 2.0 W
	backlight on - approx. 4.5 W
Dimensions (w/o bracket)	5.3" H (134 mm) x 5.2" W (133 mm)
	x 2.7" D (69 mm)
Weight	1.1 lbs (0.5 kg)
Waterproofing	U.S.C.G., CFR 46
EMI resistance	IEC 945

## FishFinder Functions

Range	Auto or manual					
FT (feet)	5	10	20	30	50	80
	100	150	250	400	600	1000
	1500	2000				
FA (fathoms)	2	3	5	10	15	20
	25	30	50	80	100	150
	200	350				
M (meters)	2	5	10	15	20	25
	30	50	80	120	200	300
	500	650				
Zoom size	x2, x4, x6, x8					
Chart speed	Freeze, slow, medium, fast					
White line	On/ Off					
Alarms	Shallow, deep, fish					
Reset distance log	0 to 999 units					
Fish symbols	5 sizes					
Output power	300 W(rms)					
Frequency	50 kHz, 200 kHz or dual operation					
Transducer beam angle	200kHz: 16° @ -6db					
	50kHz: 65° @ -6db					
Depth units	Feet, fathoms, meters					
Numerical display	3 digits (under 2.0 ft in ideal conditions)					
Water temperature	32.0 to 99.9°F (0 to 37.0°C)					
Boat speed units	Mph, kph, knots (0 to 70)					
Sensitivity	Auto or manual					

## Connector Diagrams

### DC power connector

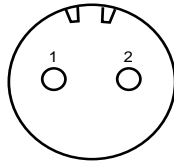

Pin 1 Ground (-)  
Pin 2 12V DC (+)

(Connectors viewed looking toward rear of display unit.)

### Transducer connector

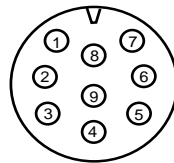

Pin 1 Depth TX+  
Pin 2 Depth TX-  
Pin 3 L Select  
Pin 4 Temp  
Pin 5 R Select  
Pin 6 Speed signal/voltage +  
Pin 7 Shield ground  
Pin 8 +12V (sidelooker)  
Pin 9 L/R receive

Fig. 6-1  
Connectors

---

## Glossary of Terms

---

**Aft:** Near or toward the rear part of the boat (nautical term).

**Background noise:** False or meaningless echo returns produced by bubbles, water turbulence, or debris

**Bow:** The front of the boat (nautical term).

**Cavitation:** Air bubbles in the water which affect the readings of a transducer. These are normally caused by mounting the transducer at an incorrect angle or location.

**Chart Speed:** The rate at which echoes scroll across the display.

**Cursor:** On a setup display, the place where the unit is ready to make a change or enter new information. This point is highlighted. You can move up or down the list or display using the  $\wedge$  and  $\vee$  controls.

**Deadrise angle:** The slope or angle of the underside of the hull, measured in the side-to-side direction.

**Default value:** A value or setting which is pre-loaded into the unit at the factory.

**Fairing block:** A block used when mounting a thru-hull transducer. The fairing block shims the transducer to align it on a perfect horizontal plane versus the rise of the hull.

**Fathom:** A unit of depth equal to 6 feet.

**Frequency:** The rate at which a sound source vibrates, or the rate at which a sound wave changes.

**Fore:** Near or toward the front part of the boat (nautical term).

**Keel:** The center of the hull, running from the bow to the stern.

**kHz:** "Kilo-Hertz" – a measure of frequency (For example, 200 kHz = 200,000 oscillations per second.)

**Kick-up bracket:** A bracket which is installed on the transom of a boat and holds the transducer in place. When the transducer strikes an obstruction, it is designed to release or "kick up" out of the water to prevent any damage.



**Knot:** One nautical mile per hour (1.15 statute miles per hour).

**LCD:** "Liquid Crystal Display" - A technology used to produce flat-panel displays.

**Nautical mile:** 6076 feet

**Port:** Left side of the boat, when facing the bow (nautical term).

**PVDF:** "Poly Vinylidene Fluoride" – A unique polymer plastic that has the ability to convert sound waves into electrical impulses. PVDF is used in the optional Sidelooker transducer for excellent detection of fish in the horizontal direction.

**Range:** The depth scale for the unit. The maximum distance the unit will be able to see at a particular range setting.

**Sensitivity:** The ability of a receiver to distinguish between echoes of different strengths. In general, use a higher sensitivity setting for deep water, and a lower setting for shallow water.

**Starboard:** Right side of the boat, when facing the bow (nautical term).

**Statute mile:** 5280 ft.

**Stern:** The rear of a boat (nautical term).

**Thermocline:** A level in the water where two areas of differing water temperature meet. Sometimes a thermocline can reflect sonar waves and present a false display.

**Transducer:** A device which sends and receives high frequency sound waves through the water.

**Transom:** The rear-most part of the boat's hull, often a flat panel.

**White Line:** A feature used to help display fish near the bottom. This feature helps to show the difference between weak returns (including fish near the bottom) and strong returns (including the bottom itself).

**Zoom:** A way of magnifying or enlarging part of the display to give a better view of a section of the water.

## Limited Warranty Certificate

Raymarine warrants each new Light Marine/Dealer Distributor Product to be of good materials and workmanship, and will repair or exchange any parts proven to be defective in material and workmanship under normal use for a period of 2 years/24 months from date of sale to end user, except as provided below.

Defects will be corrected by Raymarine or an authorized Raymarine dealer. Raymarine will, except as provided below, accept labor cost for a period of 2 years/24 months from the date of sale to end user. During this period, except for certain products, travel costs (auto mileage and tolls) up to 100 round trip highway miles (160 kilometers) and travel time of 2 hours, will be assumed by Raymarine only on products where proof of installation or commission by authorized service agents, can be shown.

### Warranty Limitations

Raymarine Warranty policy does not apply to equipment which has been subjected to accident, abuse or misuse, shipping damage, alterations, corrosion, incorrect and/or non-authorized service, or equipment on which the serial number has been altered, mutilated or removed.

Except where Raymarine or its authorized dealer has performed the installation, it assumes no responsibility for damage incurred during installation.

This Warranty does not cover routine system checkouts or alignment/calibration, unless required by replacement of part(s) in the area being aligned.

A suitable proof of purchase, showing date, place, and serial number must be made available to Raymarine or authorized service agent at the time of request for Warranty service.

Consumable items, (such as: Chart paper, lamps, fuses, batteries, styli, stylus/drive belts, radar mixer crystals/diodes, snap-in impeller carriers, impellers, impeller bearings, and impeller shaft) are specifically excluded from this Warranty.

Magnetrons, Cathode Ray Tubes (CRT), TFT Liquid Crystal Displays (LCD) and cold cathode fluorescent lamps (CCFL), hailer horns, and transducers are warranted for 1 year/12 months from date of sale. These items must be returned to a Raymarine facility.

All costs associated with transducer replacement, other than the cost of the transducer itself, are specifically excluded from this Warranty.

Overtime premium labor portion of services outside of normal working hours is not covered by this Warranty.

Travel cost allowance on certain products with a suggested retail price below \$2500.00 is not authorized. When/or if repairs are necessary, these products must be forwarded to a Raymarine facility or an authorized dealer at owner's expense will be returned via surface carrier at no cost to the owner.

Travel costs other than auto mileage, tolls and two (2) hours travel time, are specifically excluded on all products. Travel costs which are excluded from the coverage of this Warranty include but are not limited to: taxi, launch fees, aircraft rental, subsistence, customs, shipping and communication charges etc. Travel costs, mileage and time, in excess to that allowed must have prior approval in writing.

TO THE EXTENT CONSISTENT WITH STATE AND FEDERAL LAW:

(1) THIS WARRANTY IS STRICTLY LIMITED TO THE TERMS INDICATED HEREIN, AND NO OTHER WARRANTIES OR REMEDIES SHALL BE BINDING ON RAYMARINE INCLUDING WITHOUT LIMITATION ANY WARRANTIES OF MERCHANTABILITY OR FITNESS FOR A PARTICULAR PURPOSE.

(2) Raymarine shall not be liable for any incidental, consequential or special (including punitive or multiple) damages.

All Raymarine products sold or provided hereunder are merely aids to navigation. It is the responsibility of the user to exercise discretion and proper navigational skill independent of any Raymarine equipment.

# Raymarine

## Factory Service Centers

### United States of America

Raymarine, Inc.  
22 Cotton Road, Unit D  
Nashua, NH 03063-4219 USA

Telephone: +1 603 881 5200  
Fax: +1 603 864 4756  
www.raymarine.com

### Sales & Order Services

Telephone: +1 800 539 5539 Ext. 2333 or  
+1 603 881 5200 Ext 2333

### Technical Support

Telephone: +1 800 539 5539 Ext. 2444 or  
+1 603 881 5200 Ext 2444  
Email: techsupport@raymarine.com

### Product Repair Center

Telephone: +1 800 539 5539 Ext. 2118

### UK, Europe, Middle East, Far East

Raymarine Ltd  
Anchorage park, Portsmouth  
PO3 5TD, England

Telephone: +44 (0)23 9269 3611  
Fax: +44 (0)23 9269 4642  
www.raymarine.com

### Customer Support

Telephone: +44 (0)23 9271 4713  
Fax: +44 (0)23 9266 1228

Email: techsupport@raymarine.com

Stick barcode label here

Purchased from \_\_\_\_\_

Purchase date \_\_\_\_\_

Dealer address \_\_\_\_\_

Installed by \_\_\_\_\_

Installation date \_\_\_\_\_

Commissioned by \_\_\_\_\_

Commissioning date \_\_\_\_\_

Owner's name \_\_\_\_\_

Mailing address \_\_\_\_\_

This portion should be completed and retained by the owner.

## Free Manuals Download Website

<http://myh66.com>

<http://usermanuals.us>

<http://www.somanuals.com>

<http://www.4manuals.cc>

<http://www.manual-lib.com>

<http://www.404manual.com>

<http://www.luxmanual.com>

<http://aubethermostatmanual.com>

Golf course search by state

<http://golfingnear.com>

Email search by domain

<http://emailbydomain.com>

Auto manuals search

<http://auto.somanuals.com>

TV manuals search

<http://tv.somanuals.com>