

# RCA

u s e r  
m a n u a l

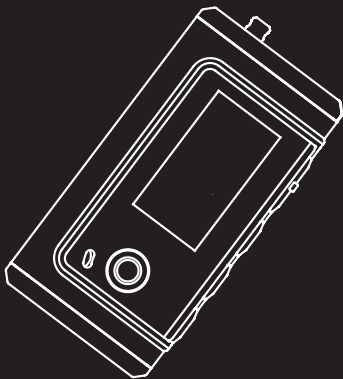

**M300**  
**M3000**  
**M3001**  
**MC300**  
**MC3000**  
**MC3001**

It is important to read this instruction book prior to using your new product for the first time.

Download from [www.Somanuals.com](http://www.Somanuals.com). All Manuals Search And Download.

# FCC Information

EN

## FCC Information

This device complies with Part 15 of the FCC Rules. Operation is subject to the following two conditions: (1) This device may not cause harmful interference, and (2) this device must accept any interference received, including interference that may cause undesired operation.

In accordance with FCC requirements, changes or modifications not expressly approved by Thomson Inc. could void the user's authority to operate this product. This equipment has been tested and found to comply with the limits for a Class B digital device, pursuant to Part 15 of FCC Rules. These limits are designed to provide reasonable protection against harmful interference in a residential installation. This equipment generates, uses, and can radiate radio frequency energy and, if not installed and used in accordance with the instructions, may cause harmful interference to radio communications. However, there is no guarantee that interference will not occur in a particular installation. If this equipment does cause harmful interference to radio or television reception, which can be determined by turning the equipment off and on, the user is encouraged to try to correct the interference by one or more of the following measures

- Reorient or relocate the receiving antenna.
- Increase the separation between the equipment and receiver.
- Connect the equipment into an outlet on a circuit different from that to which the receiver is connected.
- Consult the dealer or an experienced radio/TV technician for help.

Also, the Federal Communications Commission has prepared a helpful booklet, "How To Identify and Resolve Radio TV Interference Problems." This booklet is available from the U.S. Government Printing Office, Washington, DC 20402. Please specify stock number 004-000-00345-4 when ordering copies.

This Class B digital apparatus complies with Canadian ICES-003.

Cet appareil numérique de la class B est conforme à la norme du NMB-003 du Canada

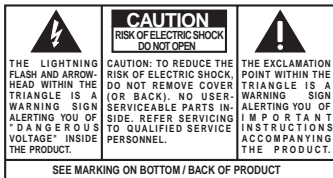

**WARNING:** TO PREVENT FIRE OR ELECTRICAL SHOCK HAZARD, DO NOT EXPOSE THIS PRODUCT TO RAIN OR MOISTURE.

The descriptions and characteristics given in this document are given as a general indication and not as a guarantee. In order to provide the highest quality product possible, we reserve the right to make any improvement or modification without prior notice. The English version serves as the final reference. On all products and operational details should any discrepancies arise in other languages.

# Safety Information

EN



RCA  
M300

Equipment tested for compliance as a complete unit



RCA  
M3000

Equipment tested for compliance as a complete unit



RCA  
M3001

Equipment tested for compliance as a complete unit



RCA  
MC300

Equipment tested for compliance as a complete unit



RCA  
MC3000

Equipment tested for compliance as a complete unit



RCA  
MC3001

Equipment tested for compliance as a complete unit

## Product Registration

Please fill out the product registration card and return it immediately. Returning this card allows us to contact you if needed.

## For Your Records

Keep your sales receipt for proof of purchase to obtain warranty parts and service.

In the event that service should be required, you may need both the model number and the serial number. In the space below, record the date and place of purchase, and the serial number:

Date of Purchase  
Place of Purchase  
Serial No.

## Technical Specification

Product: Digital Audio Player  
Brand: RCA  
Model: M300, M3000, M3001, MC300, MC3000, MC3001

## Electrical Consumption

Lithium polymer battery (internal)

IMPORTER  
Comercializadora Thomson de México, S.A. de C.V.  
Álvaro Obregón No. 151. Piso 13.  
Col. Roma. Delegación Cuauhtémoc  
C.P. 06700. México, D.F.  
Telefono: 52-55-11-020360  
RFC: CTM-980723-K55

## Service Information

This product should be serviced only by those specially trained in appropriate servicing techniques. For instructions on how to obtain service, refer to the warranty included in this Guide.

# End User License Agreement

EN

**IMPORTANT-READ CAREFULLY: This End User License Agreement ("Agreement") is a legal agreement between you and Thomson Inc. ("Thomson") for the RCA Audio Device application/driver software program and associated documentation, if any ("Program").**

## ACKNOWLEDGMENT

BY INSTALLING THE SOFTWARE OR CLICKING ON THE ACCEPTANCE BUTTON OF THE SOFTWARE, COPYING OR OTHERWISE USING THE PROGRAM, YOU ACKNOWLEDGE AND AGREE THAT YOU HAVE READ THIS AGREEMENT, UNDERSTAND IT, AND AGREE TO BE BOUND BY ITS TERMS AND CONDITIONS. IF YOU DO NOT AGREE TO THE TERMS OF THIS LICENSE AGREEMENT, CLICK ON THE REJECTION BUTTON AND/OR DO NOT INSTALL THE SOFTWARE AND/OR DO NOT USE THE PROGRAM.

## LICENSE

- a) You are granted the license (i) to use the Program on a single workstation and (ii) to make one (1) copy of the Program into any machine-readable form for backup of the Program, provided the copy contains all of the original Program's proprietary notices.
- b) You may transfer the Program and license, only as part of the Audio Device, to another party if the other party agrees to accept the terms and conditions of this Agreement. If you transfer the Program, you must at the same time either transfer all copies to the same party or destroy any copies not transferred.

# End User License Agreement

## LICENSE RESTRICTIONS

- a) Except for the licenses expressly granted to you in this Agreement, no other licenses are implied.
- b) You may not (i) modify, translate, reverse engineer, decompile, disassemble (except to the extent that this restriction is expressly prohibited by law) or create derivative works based upon the Program or (ii) copy the Program, except as expressly permitted herein. You agree that you shall only use the Program in a manner that complies with all applicable laws in the jurisdictions in which you use the Program, including, but not limited to, applicable restrictions concerning copyright and other intellectual property rights.
- c) The Program may contain pre-release code that does not perform at the level of a final code release. In this case, the Program may not operate properly. Updated versions of the Program can be downloaded from [www.rca.com](http://www.rca.com).
- d) Thomson is not obligated to provide support services for the Program.

e) The Program is provided with "RESTRICTED RIGHTS". Use, duplication, or disclosure by the U.S. Government is subject to restrictions as set forth in subparagraph (c)(1)(ii) of DFARS 252.227-7013, or FAR 52.227-19, or in FAR 52.227-14 Alt. III, as applicable.

## TERM AND TERMINATION

- a) The license is effective on the date you accept this Agreement, and remains in effect until terminated by either party.
- b) You may terminate this license without any notice or delay, by destroying or permanently erasing the Program and all copies thereof.
- c) If you use, copy, modify, or transfer the Program, or any copy, in whole or part, except as expressly provided for in this license, your license is automatically terminated.
- d) When the license is terminated, you must destroy or permanently erase the Program and all copies thereof.

# End User License Agreement

EN

## WARRANTY DISCLAIMER

THE PROGRAM IS PROVIDED "AS IS" WITHOUT WARRANTY OF ANY KIND, EITHER EXPRESSED OR IMPLIED, INCLUDING, BUT NOT LIMITED TO THE IMPLIED WARRANTIES OF MERCHANTABILITY, FITNESS FOR A PARTICULAR PURPOSE, TITLE OR NON-INFRINGEMENT. THE ENTIRE RISK AS TO THE QUALITY AND PERFORMANCE OF THE PROGRAM IS WITH YOU. SHOULD THE PROGRAM PROVE DEFECTIVE, YOU (AND NOT THOMSON, ITS SUPPLIERS, ITS AFFILIATES OR ITS DEALERS) ASSUME THE ENTIRE COST FOR ALL NECESSARY REPAIR OR CORRECTION.

This exclusion of warranty may not be allowed under some applicable laws. As a result, the above exclusion may not apply to you, and you may have other rights depending on the law that applies to you.

## OWNERSHIP RIGHTS

All title and intellectual property rights in and to the Program and any copies thereof are owned by Thomson or its suppliers. All title and intellectual property rights in and to the content which may be accessed through use of the Program is the property of the respective content owner and may be protected by applicable copyright or other intellectual property laws and treaties. This license grants you no rights to use such content.

# End User License Agreement

EN

## LIMITATION OF LIABILITY

a) TO THE MAXIMUM EXTENT PERMITTED BY APPLICABLE LAW, IN NO EVENT SHALL THOMSON, ITS AFFILIATES, OR ITS DEALERS BE LIABLE FOR ANY SPECIAL, INCIDENTAL, INDIRECT OR CONSEQUENTIAL DAMAGES WHATSOEVER (INCLUDING, WITHOUT LIMITATION, DAMAGES FOR LOSS OF PROFITS, BUSINESS INTERRUPTION, CORRUPTION OF FILES, LOSS OF BUSINESS INFORMATION OR ANY OTHER PECUNIARY LOSS) REGARDLESS OF CAUSE OR FORM OF ACTION, INCLUDING CONTRACT, TORT OR NEGLIGENCE, ARISING OUT OF THE USE OF OR INABILITY TO USE THE PROGRAM, EVEN IF THOMSON HAS BEEN ADVISED OF THE POSSIBILITY OF SUCH DAMAGES.

BECAUSE SOME STATES AND JURISDICTIONS DO NOT ALLOW THE EXCLUSION OR LIMITATION OF LIABILITY OF CONSEQUENTIAL OR INCIDENTAL DAMAGES, THE ABOVE LIMITATION MAY NOT APPLY TO YOU.

b) YOU ASSUME RESPONSIBILITY FOR THE SELECTION OF THE APPROPRIATE PROGRAM TO ACHIEVE YOUR INTENDED RESULTS, AND FOR THE INSTALLATION, USE, AND RESULTS OBTAINED.

## WINDOWS MEDIA

This version of the Audio Device Player ("The Player") contains software licensed from Microsoft that enables you to play Windows Media Audio (WMA) files ("WMA Software"). The WMA Software is licensed to you for use with the RCA/THOMSON Portable Audio Device digital music player under the following conditions. By installing and using this version of the Player, you are agreeing to these conditions. IF YOU DO NOT AGREE TO THE CONDITIONS OF THIS END USER LICENSE AGREEMENT, DO NOT INSTALL OR USE THIS VERSION OF THE Player.

# End User License Agreement

**EN**

The WMA Software is protected by copyright and other intellectual property laws. This protection also extends to documentation for the WMA Software, whether in written or electronic form.

**GRANT OF LICENSE.** The WMA Software is only licensed to you as follows: You may use this version of the Player containing the WMA Software only with the Portable Audio Device player.

You may not reverse engineer, decompile, or disassemble the WMA Software, except and only to the extent that such activity is expressly permitted by applicable law in spite of this limitation.

You may transfer your right to use this version of the Player only as part of a sale or transfer of your Portable Audio Device player, on the condition that the recipient agrees to the conditions in this End User License Agreement. If the version of the Player that you are transferring is an upgrade, you must also transfer all prior versions of the Player that you have which include the WMA Software.

MICROSOFT IS NOT PROVIDING ANY WARRANTY OF ANY KIND TO YOU FOR THE WMA SOFTWARE, AND MICROSOFT MAKES NO REPRESENTATION CONCERNING THE OPERABILITY OF THE WMA SOFTWARE.

The WMA Software is of U.S. origin. Any export of this version of the Player must comply with all applicable international and national laws, including the U.S. Export Administration Regulations, that apply to the WMA Software incorporated in the Player.



# End User License Agreement

EN

## THIRD PARTY SOFTWARE

ANY THIRD PARTY SOFTWARE THAT MAY BE PROVIDED WITH THE PROGRAM IS INCLUDED FOR USE AT YOUR OPTION. IF YOU CHOOSE TO USE SUCH THIRD PARTY SOFTWARE, THEN SUCH USE SHALL BE GOVERNED BY SUCH THIRD PARTY'S LICENSE AGREEMENT, AN ELECTRONIC COPY OF WHICH WILL BE INSTALLED IN THE APPROPRIATE FOLDER ON YOUR COMPUTER UPON INSTALLATION OF THE SOFTWARE. THOMSON IS NOT RESPONSIBLE FOR ANY THIRD PARTY'S SOFTWARE AND SHALL HAVE NO LIABILITY FOR YOUR USE OF THIRD PARTY SOFTWARE.

## GOVERNING LAW

This Agreement is governed by the laws of the State of Indiana, U.S.A. without regard to its conflict of laws.

## GENERAL TERMS

This Agreement can only be modified by a written agreement signed by you and Thomson, and changes from the terms and conditions of this Agreement made in any other manner will be of no effect. If any portion of this Agreement shall be held invalid, illegal, or unenforceable, the validity, legality, and enforceability of the remainder of the Agreement shall not in any way be affected or impaired thereby. This Agreement is the complete and exclusive statement of the agreement between you and Thomson, which supersedes all proposals or prior agreements, oral or written, and all other communications between you and Thomson, relating to the subject matter of this Agreement.

# Table of Contents

EN

## FCC Information

## Safety Information

## End User License Agreement

## Table of Contents . . . . .1

## Before You Begin . . . . .2

Accessories . . . . .2

System requirements . . . . .2

Precautions for the unit . . . . .3

Caution . . . . .3

Caution while driving . . . . .3

Headset safety . . . . .3

Important safety information . . . .4

Please respect the environment . .4

Connecting the player to your  
computer . . . . .5

## General Controls . . . . .6

## Display . . . . .7

Displaying Lyric . . . . .7

## Playback . . . . .8

Switching on and off . . . . .8

General playback . . . . .8

Repeat A-B . . . . .8

Memory function . . . . .8

## Player's Menu . . . . .9

Music . . . . .9

Voice Recording . . . . .9

Radio . . . . .10

Settings . . . . .11

Folders . . . . .11

Information . . . . .12

Language . . . . .12

Return . . . . .12

## More Information . . . . .13

Troubleshooting . . . . .13

Technical specifications . . . . .14

## U.S. Limited Warranty . . . . .15

## Canadian Limited Warranty . .17

# Before You Begin

EN

Note:

- If you are not using the player for a long time, please take out the battery to avoid leaking.
- Do not use the player under very hot, cold, dusty or wet environment.
- Unlock the HOLD switch before use.
- Avoid impact to the user while being use.
- An AAA battery allows approximately 12 hours of playback. However, the battery life may be different according to manufacturers, manufacturing time and using conditions.

Please replace your battery when:

- The battery icon gets empty,
- No response from pressing the buttons, even if after battery is reinstalled.

To avoid static electricity when using, please note the following:

- If possible, please avoid using it in rather dry environment.
- Please check whether the battery is used up when the player stops under normal operations.

## Accessories

The player is packed with the following accessories:

- Software installation CD
- USB cable
- Earphone
- User Manual
- Neckstrap

## System requirements:

- IBM compatible computer
- Processor: above Pentium 166 MHz
- Operation System: 2nd version of Win98, Win 2000, Win XP
- USB port
- Not less than 32MB memory (64 MB is preferred for Win2000 and WinXP)
- Not less than 20MB hard disk
- Not less than 4 x CD-ROM
- Network to Internet (recommended)

# Before You Begin

EN



## Warning:

Use of this product is for your personal use only. Unauthorized recording or duplication of copyrighted material may infringe upon the rights of third parties and may be contrary to copyright laws.

## Precautions for the Unit

- Do not use the unit immediately after transportation from a cold place to a warm place; condensation problem may result.
- Avoid shock to the unit.
- Do not store the unit near fire, places with high temperature or in direct sunlight.
- Do not operate or store unit in places with frequent static electricity or electrical noise (e.g. speaker, TV set).
- Clean the unit with a soft cloth or a damp chamois leather. Never use solvents.
- The unit must only be opened by qualified personnel.

## Caution

- Keep product out of direct sunlight. Exposure to direct sunlight or extreme heat (such as inside a parked car) may

cause damage or malfunction.

- Do not expose to rain or moisture.

## Caution while driving

Use of headphones while operating an automobile or moving vehicle is not recommended and is unlawful in some states and areas. Be careful and attentive on the road. Stop operation of the unit if you find it disruptive or distracting while driving.

## Headset safety



Have a Blast- Just Not in Your Eardrums

Make sure you turn down the volume on the unit before you put on

headphones. Increase the volume to the desired level only after headphone are in place.

- Do not play your headset at a high volume. Hearing experts warn against extended high-volume play.
- If you experience a ringing in your ears, reduce volume or discontinue use.
- You should use extreme caution or temporarily discontinue use in potentially hazardous situations. Even if your headset is an open-air type designed to let you hear outside sounds, don't turn up the volume so high that you are unable to hear what is around you.

# Before You Begin

## Important Battery Information

- When storing the unit, be sure to remove the battery because they may leak and damage the unit.
- Battery may leak electrolyte if inserted incorrectly, if disposed of in fire, or if an attempt is made to charge a battery not intended to be recharged.
- Discard leaky batteries immediately. Leaking batteries may cause skin burns or other personal injury.
- Do not charge batteries which are not intended to be recharged.
- Dispose of batteries, according to federal, state and local regulations.

## Please Respect the Environment!

Before throwing any batteries away, consult your distributor who may be able to take them back for specific recycling.



EN

# Before You Begin

EN

## Connecting the Player to your computer

The player can transfer music files by the USB port.

1. Lift the cover that is covering the USB port on the player.
2. Insert the USB extension cable to the USB port on the player.
3. Connect the cable to the USB port on the computer tightly.
4. This screen will appear on the display of the player.



For Win 98 users, please install the included music management software before connecting. Otherwise, the computer may not recognize the player.

Refer to the Software Instruction manual for procedures in setting up USB drivers and transferring files to the player.



### Note

Refer to the Software Instruction manual for procedures in setting up USB drivers and transferring files to the player.

# General Controls

EN

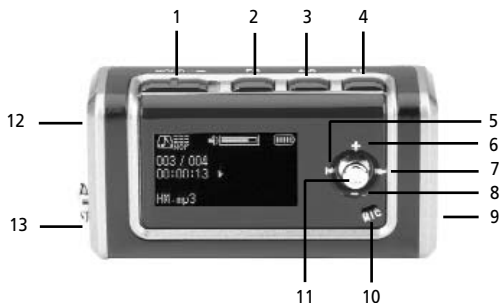

**1. Hold** - to lock the player's keys.

**2. EQ** - to select EQ mode.

**3. A-B** - to select a section of a music / recorded file for A-B repeat / to start record.

**4. Play/Pause** - to turn on / off the player, to start, pause or stop playback

**5. REW** - to skip backward, to start fast backward playback.

**6. +** - to increase volume.

**7. FF** - to skip forward, to start fast forward playback

**8. -** - to decrease volume.

**9. USB** - to connect with computer via a USB cable. Open the cover when use.

**10. MIC** - microphone for recording.

**11. M** - to access player's menu.

**12. OPEN** - battery compartment. Slide open the door to install battery.

**13. Headphone jack**

# Display

EN

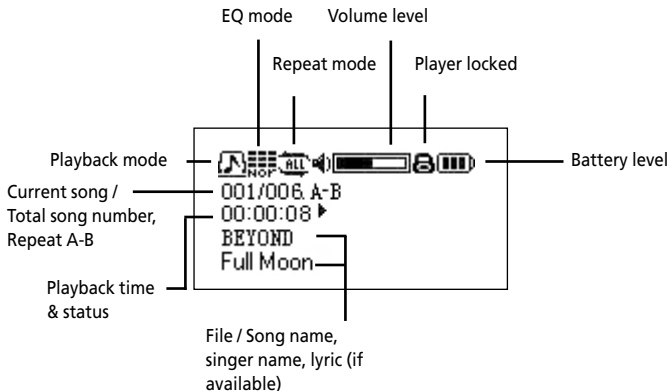

## Displaying Lyric

Lyric files are of LRC format and they should have the same name with the corresponding music files. You can download them by "Mini Lyric" or make them by special tools.

When playing music files with lyrics, they will be shown in 2 lines at the bottom of the display.

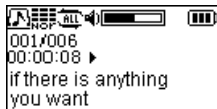



# Playback

EN

## Switching on and off

- To switch on the player, press the **Play/Pause** button and a start-up screen will appear on the display.
- To switch off the player, press the **Play/Pause** button for about 2 seconds until a switch off screen appears on the display. Press and hold until the progress bar reaches its end.

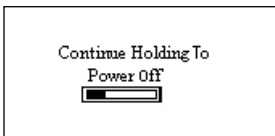

## General Playback

- After the player is switched on, press **Play/Pause** button to begin playback.
- Press **FF** or **REW** button to select next or previous music / recorded file.
- Press **+** or **-** button to increase or decrease volume.
- Press and hold **FF** or **REW** button during playback to play forward or backward music quickly.

Note: The battery level may vary during playback according to different level of power consumption.

## Repeat A-B

To repeat a section between two points A and B in your currently playing music / recorded file.

- During playback, press **A-B** button at the beginning of your repeat section. "A-" shows on the display.
- Press **A-B** button at the end of your repeat section. "A-B" shows on the display.

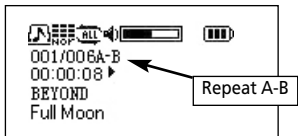

- The section will repeat continuously until you press **A-B** button again.

## Memory function

The player has memory function after switch off, it can recall the most recent settings (including playback file, language, EQ, Repeat, Power Save, radio channel and volume settings) for your next use.

# Player's Menu

**EN** Press **M** button to access the player's menu.

Press **FF** or **REW** button to select one of the menu items and then press **M** to enter into the item.



## Music

Select this item in the player's menu for the playback of music files. Refer to the previous page for playback operations.

### A short-cut for recording:

Press and hold **A-B** button until recording starts, press **Play/Pause** to stop recording.

## Voice Recording

Select this item in the player's menu for recording. Recording starts immediately after you have selected this menu item. Press **Play/Pause** button to stop recording.

Refer to the "Folders" section for the playback of recordings.

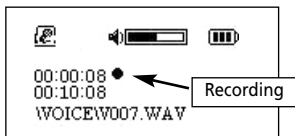

# Player's Menu

EN

## Radio

Select this item in the player's menu for listening to the radio.



### Adjusting frequencies

#### Radio automatic channel search:

After the first time you selected the radio mode, the player will automatically search for radio channels and store them all up for you. Press and hold **FF** button and the player will start automatic channel search all over again. After automatic channel search is done, press **FF** or **REW** button to select and listen to a preset channel.

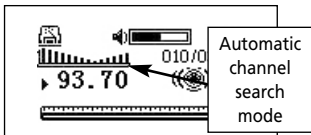

#### Radio manual channel search:

After the radio mode is selected, press **M** once to select manual channel search mode. Press **FF** or **REW** button to tune up or down frequencies at 50kHz intervals.

Press **A-B** button to save the frequency you have selected manually. You can save up to 30 radio channels.

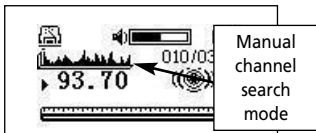

### Recording the radio

In radio mode, press and hold **A-B** button until recording starts. Press **Play/Pause** to stop recording. Refer to the "Folders" section for the playback of recordings. All radio recorded files will be saved in "FM" folder.

### Switching off the radio

Press and hold **M** button to switch off the radio and return to the music playback mode.

# Player's Menu

## EN Settings

Select this item in the player's menu for setting EQ mode, repeat mode and power save mode. In the Settings menu, press **FF** or **REW** button to select one of the settings and then press **M** button to enter into selected item.

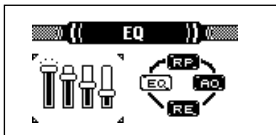

**EQ** – EQ mode (for sound effects)

**RP** – Repeat mode (for repeat or shuffle playback)

**AO** – Power Save mode (for automatic power off when the player is idle)

**RE** – Return to the previous menu

In each of the above menu, press + or - button to select one of the options and then press **M** button to confirm the selection.

Options available within each menu:

**EQ** – Normal, Rock, Jazz, Classical, Pop, Bass and exit

**Repeat Mode** – Normal, Repeat Track (repeat the current music / recorded file continuously), Repeat All (repeat all music / recorded files continuously), Shuffle (random playback), Shuffle Repeat (random playback continuously), Playlist (playback of selected music / recorded files, refer to the "Folders" section) and exit.

**Power Save** – Disable, 1, 2, 5, and 10 minutes. (Note: if "Disable" is selected, the player will not switch off even if it is left idle.)

## Folders

Select this item in the player's menu for browsing the music / recorded files directory. Press + or - button to browse files within the same folder. Press **FF** button to enter into a folder and press **REW** to exit a folder. Voice recorded files will be saved in the "VOICE" folder and radio recorded files in the "FM" folder.



# Player's Menu

EN

You can also select music / recorded files into the Playlist for playback.

1. Select a music / recorded file from the file directory and then press **M** button to show a sub-menu.
2. Press **+** or **-** button to select "Playlist" and then press **M** button.  
(Note: Select "Play" will start playback of the selected file, "Delete" will erase the file from the player and "Exit" to exit this sub-menu.)
3. Select "Add" by pressing **+** or **-** button and then press **M** button to add the music / recorded file into the Playlist..

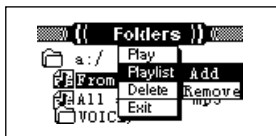

## Playback of the Playlist

Select Repeat mode from the Settings menu and then select Playlist. Refer to the section "Settings" for details.

## Information

Select this item in the player's menu for checking total and free memory of the player and the firmware version.

Note: if the total and free memories are not correctly shown in the player, please format the player again with the music management software provided. You

can also download the software from <http://www.rca.com/digitalaudiowdownlo> ads

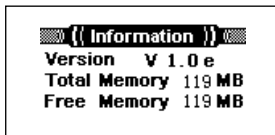

## Language

Select this item in the player's menu for setting player's display language. All the display and ID3 information will show in the selected language. Press **+** or **-** button to select a language and press **M** button to confirm selection.



## Return

Select this item in the player's menu for exiting the player's menu.

# More Information

EN

## Note:

We strongly suggest users to install the music management software first before connecting the player to the computer.

Plug and Play function is only for Win2000 and WinXP. Win98 and Win 98SE users have to install the driver.

## Troubleshooting

### The play button does not function.

- There is no battery or the battery has been used up.
- Check if the battery is correctly installed.

### The buttons do not function when the player is switched on.

- The buttons are locked. Check the **HOLD** button.

### After connection with a PC, the mobile storage icon of the player could not be found.

- Driver may not be installed or the application has been corrupted. Install the application again.

### The time display is not showing correctly when some music is played.

- Some mp3 files are compressed with the VBR format that will cause the time to show incorrectly with the change of bit rate. Playback should be of no problem. Compress the files with fixed rate format.

### Unplugging the player from the computer causes malfunction.

- Do not unplug the player while transferring files to the player.

### Some music cannot be played.

- The music format supported:  
MPEG 1 Layer 3, MPEG 1 Layer 2, MPEG 1 Layer 1, MPEG2 Layer 3, MPEG 2.5 Layer 3 and WMA.  
MP3: 32Kbps ~ 320Kbps  
WMA: 64 Kbps ~ 192Kbps  
Delete the music files and compress the music according to the standards.

### The free memory shown and the actual memory available is not the same.

- The player needs space to store applications. The available memory may be smaller than actual.

### All settings are lost.

- Settings are saved in .dat file. All settings are lost if you delete this file.

# More Information

## Technical Specifications

Memory: 64/128/256/512M/1G (Built inside)

Battery: 1x AAA battery

LCD: 128x64 pixels, OLED

Signal / noise: >75dB

Earphone output: 5mW + 5mW

Music format: MP3, WMA

Record format: PCM WAV



### Note:

This unit may temporarily cease to function if

subjected to electrostatic disturbance. To resume to normal operation, it may be necessary to switch the power off and on again or to remove or reinstall the battery.

EN

# U.S. Limited Warranty

EN

## What your warranty covers:

- Defects in materials or workmanship.

## For how long after your purchase:

- One year from date of purchase.

The warranty period for rental units begins with the first rental or 45 days from date of shipment to the rental firm, whichever comes first.

## What we will do:

- Provide you with a new, or at our option, a refurbished unit. The exchange unit is under warranty for the remainder of the original product's warranty period.
- Proof of purchase in the form of a bill of sale or receipted invoice which is evidence that the product is within the warranty period must be presented to obtain warranty service. For rental firms, proof of first rental is also required.

## How to make a warranty claim:

- Properly pack your unit. Include any cables, etc., which were originally provided with the product. We recommend using the original carton and packing materials.
- Include evidence of purchase date such as the bill of sale. Also print your name and address and a description of the defect. Send via standard UPS or its equivalent to:

**Thomson Inc.  
Product Exchange Center  
11721 B Alameda Avenue  
Socorro, Texas 79927**

- Insure your shipment for loss or damage. Thomson accepts no liability in case of damage or loss en route to Thomson.
- Pay any charges billed to you by the Exchange Center for service not covered by the warranty.
- A new or refurbished unit will be shipped to you freight prepaid.

## What your warranty does not cover:

- Customer instruction. (Your Owner's Manual provides information regarding operating Instructions and user controls. For additional information, ask your dealer.)
- Installation and set-up service adjustments.
- Batteries.
- Damage from misuse or neglect.
- Products which have been modified or incorporated into other products.
- Products purchased or serviced outside the USA.
- Acts of nature, such as but not limited to lightning damage.



# U.S. Limited Warranty

EN

## **Product Registration:**

- Please complete and mail the Product registration Card packed with your unit. It will make it easier to contact you should it ever be necessary. The return of the card is not required for warranty coverage.

## **Limitation of Warranty:**

- **THE WARRANTY STATED ABOVE IS THE ONLY WARRANTY APPLICABLE TO THIS PRODUCT. ALL OTHER WARRANTIES, EXPRESS OR IMPLIED (INCLUDING ALL IMPLIED WARRANTIES OF MERCHANTABILITY OR FITNESS FOR A PARTICULAR PURPOSE) ARE HEREBY DISCLAIMED. NO VERBAL OR WRITTEN INFORMATION GIVEN BY THOMSON INC., ITS AGENTS OR EMPLOYEES SHALL CREATE A WARRANTY OR IN ANY WAY INCREASE THE SCOPE OF THIS WARRANTY.**
- **REPAIR OR REPLACEMENT AS PROVIDED UNDER THIS WARRANTY IS THE EXCLUSIVE REMEDY OF THE CONSUMER. THOMSON INC. SHALL NOT BE LIABLE FOR INCIDENTAL OR CONSEQUENTIAL DAMAGES RESULTING FROM THE USE OF THIS PRODUCT OR ARISING OUT OF ANY BREACH OF ANY EXPRESS OR IMPLIED WARRANTY ON THIS PRODUCT. THIS DISCLAIMER OF WARRANTIES AND LIMITED WARRANTY ARE GOVERNED BY THE LAWS OF THE STATE OF INDIANA. EXCEPT TO THE EXTENT PROHIBITED BY APPLICABLE LAW, ANY IMPLIED WARRANTY OF MERCHANTABILITY OR FITNESS FOR A PARTICULAR PURPOSE ON THIS PRODUCT IS LIMITED TO THE APPLICABLE WARRANTY PERIOD SET FORTH ABOVE.**

## **How state law relates to this warranty:**

- Some states do not allow the exclusion nor limitation of incidental or consequential damages, or limitations on how long an implied warranty lasts, so the above limitations or exclusions may not apply to you.
- This warranty gives you specific legal rights, and you also may have other rights that vary from state to state.

## **If you purchased your product outside the USA:**

- This warranty does not apply. Contact your dealer for warranty information.

# Canadian Limited Warranty

EN

Thomson multimedia Ltd. warrants to the purchaser or gift recipient that if any manufacturing defect becomes apparent in this product within 1 year from the original date of purchase, it will be replaced free of charge, including return transportation.

This warranty does not include damage to the product resulting from accidents, misuse or leaking batteries.

Should your product not perform properly during the warranty period, either:

1. Return it to the selling dealer with proof of purchase for replacement,

OR

2. Remove the batteries (where applicable), and pack product complete with accessories in the original carton (or equivalent).

— Mail prepaid (with proof of purchase) and insured to:

**Thomson multimedia Ltd.**  
**6200 Edwards Blvd.,**  
**Mississauga, Ontario L5T 2V7**  
**Canada**

The provisions of this written warranty are in addition to and not a modification of or subtraction from the statutory warranties and other rights and remedies contained in any applicable legislation, and to the extent that any such provisions purport to disclaim, exclude or limit any such statutory warranties and other rights and remedies, such provisions shall be deemed to be amended to the extent necessary to comply therewith.

If you are unable to find a qualified servicer for out of warranty service, you may write to:

Thomson Inc.

P.O. Box 0944

Indianapolis, Indiana, U.S.A., 46206-0944

Attach your sales receipt to this booklet for future reference. This information is required if service is needed during the warranty period.

PURCHASE DATE

NAME OF STORE

---

**IMPORTADOR**

**Comercializadora Thomson de México, S.A. de C.V.**  
**Álvaro Obregón No. 151. Piso 13.**  
**Col. Roma. Delegación Cuauhtémoc**  
**C.P. 06700. México, D.F.**  
**Telefono: 52-55-11-020360**  
**RFC: CTM-980723-KS5**

**Thomson Inc.**  
**P.O. Box 1976**  
**Indianapolis, IN 46206-1976**  
**© 2006 Thomson Inc.**  
**Trademark(s) ® Registered**  
**Marca(s) ® Registrada(s)**  
**Marque(s) ® Deposée(s)**  
**www.rca.com**

**Printed In China / Impreso en China**

**Tocom (v1.0)**

## Free Manuals Download Website

<http://myh66.com>

<http://usermanuals.us>

<http://www.somanuals.com>

<http://www.4manuals.cc>

<http://www.manual-lib.com>

<http://www.404manual.com>

<http://www.luxmanual.com>

<http://aubethermostatmanual.com>

Golf course search by state

<http://golfingnear.com>

Email search by domain

<http://emailbydomain.com>

Auto manuals search

<http://auto.somanuals.com>

TV manuals search

<http://tv.somanuals.com>