

It's important to read this instruction prior to using your new product for the first time.

SAFETY PRECAUTIONS

The following marks and symbols are located on the back of the unit.



CAUTION: TO REDUCE THE RISK OF ELECTRIC SHOCK, DO NOT REMOVE COVER (OR BACK). NO USER-SERVICEABLE PARTS INSIDE. REFER SERVICING TO QUALIFIED SERVICE PERSONNEL.

WARNING: TO PREVENT FIRE OR SHOCK HAZARD, DO NOT EXPOSE THIS APPLIANCE TO RAIN OR MOISTURE.



CAUTION : Invisible laser radiation when open. Avoid exposure to beam.

ATTENTION: Radiation invisibles du laser en cas d'ouverture et de défaillance ou de mise hors service du dispositif de verrouillage. Eviter toute exposition directe au faisceau.

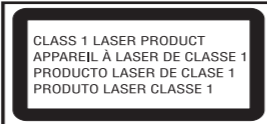

The symbol for Class II (Double Insulation)

This product contains a low power laser device.

Warnings

- The apparatus shall not be exposed to dripping or splashing and that no objects filled with liquids, such as vases, shall be placed on apparatus.
- The AC adapter is used as disconnect device and it should remain readily operable during intended used. In order to disconnect the apparatus from the mains completely, the AC adapter should be disconnected from the mains socket outlet completely.
- Minimum 10 cm (4 inches) distances around the apparatus for sufficient ventilation.
- Batteries shall not be exposed to excessive heat such as sunshine, fire or the like.
- Do not restrict the airflow of the unit by placing it in a place with poor airflow, by covering it with a cloth, or by placing it on carpeting.
- No naked flame sources such as lighted candles should be placed on the apparatus.

PRECAUTIONS

Follow the advice below for safe and appropriate operations.

ON PLACEMENT

- Do not use the unit in places which are extremely hot, cold, dusty, or humid.
- Place the unit on a flat and even surface.
- Do not restrict the air flow of the unit by placing it in a place with poor air flow, by covering it with a cloth, or by placing it on a carpet.

ON SAFETY

- Before operating, make sure that the rated voltage of the AC adapter matches your local voltage.
- When you are not going to use the unit for a long period of time, disconnect the AC adapter.

ON CONDENSATION

- When left in a heated room where it is warm and damp, water droplets or condensation may form inside the CD player.
- When there is condensation inside the unit, the unit may not function normally.
- Let it stand for 1 to 2 hours before turning the power on, or gradually heat the room and allow the unit to dry before use.

FCC INFORMATION

This device complies with Part 15 of the FCC rules. Operation is subject to the following two conditions: (1) This device may not cause harmful interference, and (2) This device must accept any interference received, including interference that may cause undesired operation.

Note: This equipment has been tested and found to comply with the limits for a Class B digital device, pursuant to Part 15 of the FCC Rules. These limits are designed to provide reasonable protection against harmful interference in a residential installation. This equipment generates, uses, and can radiate radio frequency energy and, if not installed and used in accordance with the instructions, may cause harmful interference to radio communications. However, there is no guarantee that interference will not occur in a particular installation. If this equipment does cause harmful interference to radio or television reception, which can be determined by turning the equipment off and on, the user is encouraged to try to correct the interference by one or more of the following measures:

- Reorient or relocate the receiving antenna.
- Increase the separation between the equipment and receiver.
- Connect the equipment into an AC power outlet that is on a circuit different from the one the receiver is connected.
- Consult the dealer or an experienced radio/TV technician for help.

Warnings: Changes or modifications to this unit not expressly approved by the party responsible for compliance could void the user's authority to operate the equipment.

This Class B digital apparatus complies with Canadian ICES-003. Cet appareil numérique de la classe B est conforme à la norme NMB-003 du Canada.

IMPORTANT SAFETY INSTRUCTIONS

- Read these instructions.
- Keep these instructions.
- Heed all warnings.
- Follow all instructions.
- Do not use this apparatus near water.
- Clean only with a dry cloth.
- Do not block any of the ventilation openings. Install in accordance with the manufacturer's instructions.
- Do not install near any heat sources such as radiators, heat registers, stoves, or other apparatus (including amplifiers) that produce heat.
- Do not defeat the safety purpose of the polarized or grounding-type plug. A polarized plug has two blades with one wider than the other. A grounding type plug has two blades and a third grounding prong. The wide blade or the third prong are provided for your safety. If the provided plug does not fit into your AC power outlet, consult an electrician for replacement of the obsolete outlet.
- Protect the AC power cord from being walked on or pinched particularly at plugs, convenience receptacles, and the point where they exit from the apparatus.
- Only use attachments/accessories specified by the manufacturer.
- Use only with a cart, stand, tripod, bracket, or table specified by the manufacturer, or sold with the apparatus. When a cart is used, use caution when moving the cart/apparatus combination to avoid injury from tip-over.



Portable Cart Warning

- Unplug this apparatus during lightning storms or when unused for long periods of time.
- Refer all servicing to qualified service personnel. Servicing is required when the apparatus has been damaged in any way, such as the AC power cord or plug is damaged, liquid has spilled or objects have fallen into the apparatus, the apparatus has been exposed to rain or moisture, does not operate normally, or has been dropped.

SYSTEM CONNECTIONS

1. CONNECTING THE SPEAKERS

Connect the wires to the speaker terminals.

Note: Connecting speakers other than the speakers supplied with the unit, may damage the unit.

2. USING THE AC ADAPTER

Before use, make sure that the rated voltage of your AC adapter matches your local voltage. Make sure both speakers are connected correctly before plugging the AC adapter cord into the AC power outlet.

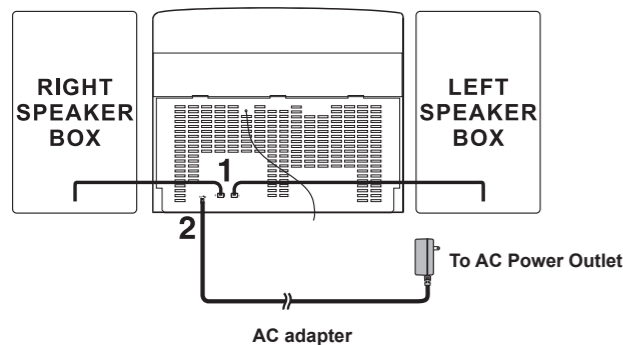

SYSTEM CONNECTIONS

3. CONNECTING WITH OTHER OPTIONAL EQUIPMENT

Listening to the Audio Signals from the External Equipment

- Connect the AC adapter to the AC power outlet.
- Slide the FUNCTION selector to the AUX position. The AUX IN indicator lights up.
- Turn on your audio equipment and play the external source.

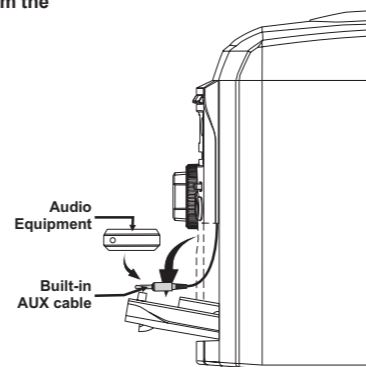

Storing the Built-in AUX Cable

- Place the built-in AUX cable inside the tray.
- Gently push the tray door up until it is closed.

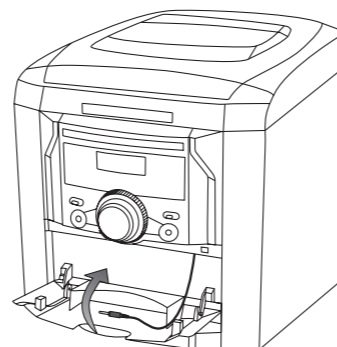

LOCATION OF FCC CONTROLS

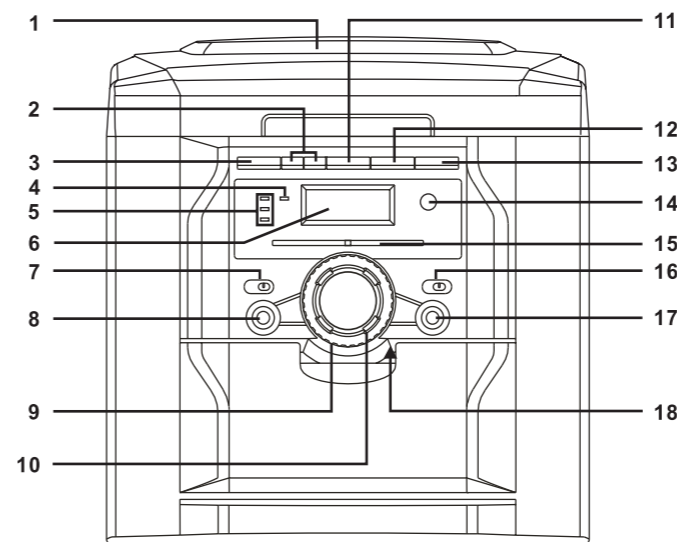

- | | |
|---|---------------------------|
| 1. CD Door | 9. TUNING Control |
| 2. ⏪ SKIP/SEARCH ⏩ Buttons | 10. VOLUME Control |
| 3. ➡ REPEAT Button | 11. ⏻ DISC SKIP Button |
| 4. POWER Indicator | 12. ■ STOP Button |
| 5. REPEAT Indicators (ONE SONG / ONE DISC / ALL DISC) | 13. ▶ PLAY/PAUSE Button |
| 6. CD Display | 14. Remote Sensor |
| 7. FUNCTION Selector (OFF/TUNER/AUX/CD) | 15. Dial Scale |
| 8. 📞 PHONES Jack | 16. BAND Selector (AM/FM) |
| | 17. AUX IN Indicator |
| | 18. AUX IN Cable |

RADIO OPERATION

- Slide the FUNCTION selector to TUNER. The POWER indicator lights up.

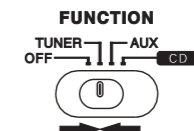

- Slide the BAND selector to desired band (AM/FM).

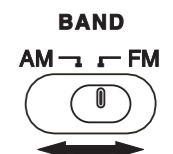

- Tune into a station.

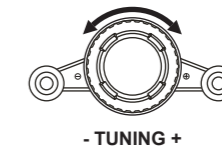

- Adjust the volume level.

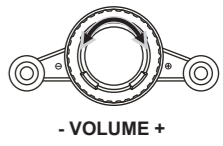

FOR BETTER RECEPTION

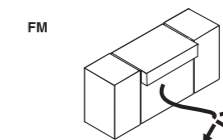

Fully unwind the wire antenna. Then extend the wire antenna and place it in the position that sounds best. (When the FM broadcast signal is strong, it can receive FM Stereo Broadcast.)

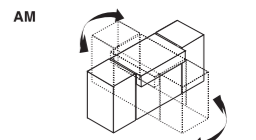

Rotate the unit to get the best receiving position.

NOTE: DO NOT CONNECT TO AN OUTSIDE ANTENNA.

AFTER LISTENING

Slide the FUNCTION selector to OFF.

COMPACT DISC PLAYBACK

- Slide the FUNCTION selector to CD. The POWER indicator lights up.
- Open the disc compartment.

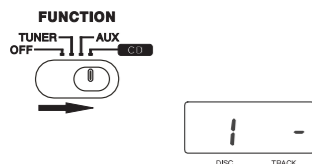

- Place a disc onto the disc(s) holder, with the label side up.
- Press the DISC SKIP button to revolve the tray clockwise. Place other disc(s) on the disc holder(s).

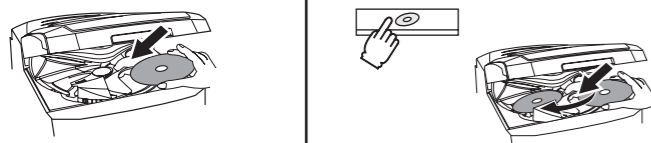

- Close the CD door by gently pushing down until it is secure. The disc no. and the total number of tracks will show in the CD display for a few seconds.



- Press the DISC SKIP button to select the desired disc. Press either the $⏮$ SKIP or SEARCH $⏭$ button to select the desired track.

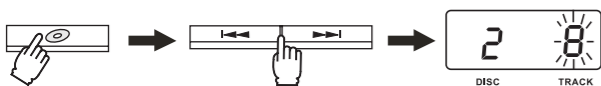

- 9 -

COMPACT DISC PLAYBACK

- Press the PLAY/PAUSE $⏩$ button to start playback.



To Stop Playing:

- Press the PLAY/PAUSE $⏩$ button and the track no. will flash. Press this button again to resume playing.
- Press the STOP $■$ button.

Note: The $⏮$ SKIP or SEARCH $⏭$ button can only be used to choose a track on the current disc. To choose a track of another disc, the DISC SKIP button should be pressed to get to the desired disc first.

To Skip to a Different Track

- To skip to the beginning of the current or the previous track, press the $⏮$ reverse skip button.
- To skip to the beginning of the next track, press the $⏭$ forward skip button.
- A short period of time will be needed for the disc to read the information of the desired track before playback can begin.

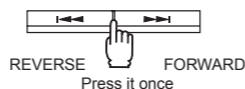

To Fast Forward or Fast Reverse to a Particular Point

- To scan forward at high speed, press and hold the $⏭$ forward search button and release it at the desired point.
- To scan backward at high speed, press and hold the $⏮$ reverse search button and release it at the desired point.
- Fast forward or fast reverse will continue searching the CD until it reaches the end.

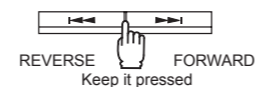

Note: Searching and skipping can be done during playback or pause mode but are effective for the currently selected disc only. Use the DISC SKIP button to choose another disc.

- 10 -

COMPACT DISC PLAYBACK

REPEAT PLAYBACK DURING PLAYBACK MODE

To Repeat the Current Track

- Press the $⏮$ REPEAT button until the ONE SONG indicator lights up. The current track will be played repeatedly until the STOP $■$ button is pressed.



To Repeat the Whole Disc

- Press the $⏮$ REPEAT button until the ONE DISC indicator lights up. The current disc will be played repeatedly starting from the current playing point.



To Repeat all Discs

- Press the $⏮$ REPEAT button until the ALL DISC indicator lights up.



To Cancel Repeat Play

- Press the $⏮$ REPEAT button until all indicators turn off.



- 11 -

REMOTE CONTROL

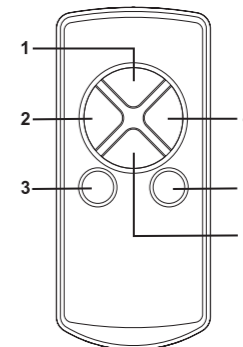

- PLAY/PAUSE $⏩$ Button
- $⏮$ SKIP/SEARCH Button
- DISC SKIP Button
- $⏭$ SKIP/SEARCH Button
- $⏮$ REPEAT Button
- $■$ STOP Button

USING THE REMOTE CONTROL CORRECTLY

- Point the remote control at the REMOTE SENSOR located on the unit.
- When there is a strong ambient light source, the performance of the infrared REMOTE SENSOR may be degraded, causing unreliable operation.
- The recommended effective distance for remote operation is about 13 feet.

- Remove the protective plastic tab before operating the remote control.

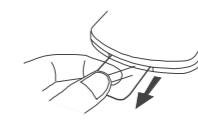

- To change battery

- Open the battery door.



- Insert one CR2025 (3V) size battery.



BATTERY REPLACEMENT

When the battery becomes weak, the operating distance of the remote control is greatly reduced and you will need to replace the battery.

CAUTION: Danger of explosion if battery is incorrectly replaced. Replace only with the same or equivalent type.

NOTE: If the remote control is not going to be used for a long time, remove the battery to avoid damage caused by battery leakage corrosion.

WARNINGS:

- Do not dispose of battery in fire. Battery may explode or leak.
- Batteries shall not be exposed to excessive heat such as sunshine, fire or the like.

- 12 -

TROUBLESHOOTING GUIDE

SYMPTOM	CAUSE (AND REMEDY)
No sound	<ul style="list-style-type: none"> Turn VOLUME clockwise. The headphones are connected. Disconnect them.
No sound from one channel or unbalanced left and right volume	<ul style="list-style-type: none"> Check the speaker connections of the inoperative channel.
Reversed left and right sound	<ul style="list-style-type: none"> Check the speaker cord connection and speaker location.
Lack of bass sound or imprecise physical location of musical instruments	<ul style="list-style-type: none"> Check the speaker connection for proper phasing.
Severe hum or noise	<ul style="list-style-type: none"> The TV or VCR is too close to the stereo system. Separate the stereo system from the TV or VCR.
CD	
Disc in place but unit won't play	<ul style="list-style-type: none"> Make sure the AC adapter is secure in the AC power outlet, and the outlet has power. Make sure FUNCTION selector is set to CD. Make sure disc label is facing up. Make sure disc is clean. Pause mode is activated. Disc may be damaged or dirty; check disc.
Disc skips	<ul style="list-style-type: none"> Make sure the unit is on a secure spot. Vibration or jarring can cause the disc to skip.
RADIO	
Poor FM reception	<ul style="list-style-type: none"> Make sure FM antenna wire is unbound. Electrical interference in your home can cause poor reception. Move the unit away from sources of interference (especially those with motors and transformers).
Poor AM reception	<ul style="list-style-type: none"> Reposition or turn the main unit for better reception.

- 13 -

MAINTENANCE



CLEANING THE DISC

If the CD skips or will not play, the disc may need to be cleaned. Before playing, wipe the disc from the center outward with a cleaning cloth. After playing, store the disc in its case.

CLEANING THE UNIT

Do not use volatile chemicals on this unit. Clean by lightly wiping with a soft cloth.

IMPORTANT NOTE

- If an abnormal display indication or an operating problem occurs, disconnect the AC adapter. Wait at least 5 seconds, then reconnect it.
- Before transporting the unit, remove all discs from the disc compartment.

SPECIFICATIONS

Power consumption:	10 W
Power source:	AC 120V~60Hz

- 14 -

LIMITED WARRANTY

AVC MULTIMEDIA ("AVC") makes the following limited warranty. These limited warranties extend to the original consumer purchaser and is limited to non-commercial user of the product.

One Year Parts & Labor Warranty

AVC products purchased in the United States are warranted to be free from defects in materials or workmanship for a period of one year from the date of their original retail purchase. If the unit fails to conform to this warranty, we will service the product using new or refurbished parts and products, at AVC's sole discretion.

During a period of one year from the effective warranty date, AVC will provide, when needed, service labor to repair a manufacturing defect at its designated Service Center. To obtain warranty service in the United States, you must first call our **Customer Support Center at 1-877-252-6873, during the hours listed in the box below.** The determination of service will be made by AVC customer support.

PLEASE DO NOT RETURN YOUR UNIT TO AVC WITHOUT PRIOR AUTHORIZATION. New or remanufactured replacements for defective parts or products will be used for repairs by AVC at its designated Service Center for one year from the defective warranty date. Such replacement parts or products are warranted for an additional one year from the date of repair or replacement. The Customer will be required to ship the unit to the Service Center indicated at the time Customer Support is contacted to make the necessary repairs. The customer is responsible for all transportation charges to the service facility.

Packaging and Shipping Instruction

When you send the product to the AVC service facility you must use the original carton box and packing material or an equivalent as designated by AVC.

Your Responsibility

- You must retain your bill of sale to provide proof of purchase.
- These warranties are effective only if the product is purchased and operated in the U.S.A. or Canada.
- Warranties extend only to defects in material or workmanship, and do not extend to any product or parts which have been lost or discarded, or damage to product or parts caused by misuse, accident, improper operation or maintenance, or use in violation of instructions provided with the product, or to product which has been altered or modified without authorization of AVC, or to products or parts thereof which have had the serial number removed or changed.

Out of Warranty

In the event your product requires repair after the limited warranty period has expired, please contact our Customer Support Center at **1-877-252-6873** or **www.RCAav.com**
Hours: Monday-Thursday: 9am-7pm, Friday: 9am-5pm, Saturday: 9am-NOON Eastern time.
Important:
You are responsible for any transportation, shipping or insurance relative to the return of the product to our Product Returns Center.

- 15 -

LIMITED WARRANTY

All warranties implied by state law, including the implied warranties of merchantability and fitness for a particular purpose, are expressly limited to the duration of the limited warranties set forth above. With the exception of any warranties implied by state law as hereby limited, the foregoing warranty is exclusive and in lieu of all other warranties, guarantees, agreements and similar obligations of manufacturer or seller with respect to the repair or replacement of any parts. In no event shall AVC be liable for consequential or incidental damages.

No person, agent, distributor, dealer or company is authorized to change, modify or extend the terms of these warranties in any manner whatsoever. The time within action must be commenced to enforce any obligation of AVC arising under the warranty or under any statute, or law of the United States or any state thereof, is hereby limited to one year from the date of purchase. This limitation does not apply to implied warranties arising under state law.

This warranty gives you specific legal rights and you may also have other rights, which may vary from state to state. Some states do not allow limitation on how long an implied warranty lasts, when an action may be brought, or the exclusion or limitation of incidental or consequential damages, so the above provisions may not apply to you.

For more information on other products and services, please contact our web site at **www.RCAav.com**

Important: Also keep your "Bill of Sale" as proof of purchase.

Model no Product name
Type of set
Serial no Invoice no
Date purchased Dealer name

FOR SUPPORT, SERVICE AND REPAIR, PLEASE VISIT **www.RCAav.com**.

Specifications and external appearance are subject to change without notice.

Printed in China

811-216291W100

Free Manuals Download Website

<http://myh66.com>

<http://usermanuals.us>

<http://www.somanuals.com>

<http://www.4manuals.cc>

<http://www.manual-lib.com>

<http://www.404manual.com>

<http://www.luxmanual.com>

<http://aubethermostatmanual.com>

Golf course search by state

<http://golfingnear.com>

Email search by domain

<http://emailbydomain.com>

Auto manuals search

<http://auto.somanuals.com>

TV manuals search

<http://tv.somanuals.com>