



M34514T-MCU

MCU Board for 4513/4514 Group MCUs

User's Manual

- * MS-DOS is a registered trademark of Microsoft Corporation.
- * IBM and AT are registered trademarks of International Business Machines Corporation.
- * NQPACK, YQPACK, YQSOCKET, YQ-GUIDE, HQPACK, TQPACK and TQSOCKET are trademarks of Tokyo Eletech Corporation.

Keep safety first in your circuit designs!

- Renesas Technology Corporation and Renesas Solutions Corporation put the maximum effort into making semiconductor products better and more reliable, but there is always the possibility that trouble may occur with them. Trouble with semiconductors may lead to personal injury, fire or property damage. Remember to give due consideration to safety when making your circuit designs, with appropriate measures such as (i) placement of substitutive, auxiliary circuits, (ii) use of nonflammable material or (iii) prevention against any malfunction or mishap.

Notes regarding these materials

- These materials are intended as a reference to assist our customers in the selection of the Renesas Technology product best suited to the customer's application; they do not convey any license under any intellectual property rights, or any other rights, belonging to Renesas Technology Corporation, Renesas Solutions Corporation or a third party.
- Renesas Technology Corporation and Renesas Solutions Corporation assume no responsibility for any damage, or infringement of any third-party's rights, originating in the use of any product data, diagrams, charts, programs, algorithms, or circuit application examples contained in these materials.
- All information contained in these materials, including product data, diagrams, charts, programs and algorithms represents information on products at the time of publication of these materials, and are subject to change by Renesas Technology Corporation and Renesas Solutions Corporation without notice due to product improvements or other reasons. It is therefore recommended that customers contact Renesas Technology Corporation, Renesas Solutions Corporation or an authorized Renesas Technology product distributor for the latest product information before purchasing a product listed herein. The information described here may contain technical inaccuracies or typographical errors. Renesas Technology Corporation and Renesas Solutions Corporation assume no responsibility for any damage, liability, or other loss rising from these inaccuracies or errors. Please also pay attention to information published by Renesas Technology Corporation and Renesas Solutions Corporation by various means, including the Renesas home page (<http://www.renesas.com>).
- When using any or all of the information contained in these materials, including product data, diagrams, charts, programs, and algorithms, please be sure to evaluate all information as a total system before making a final decision on the applicability of the information and products. Renesas Technology Corporation and Renesas Solutions Corporation assume no responsibility for any damage, liability or other loss resulting from the information contained herein.
- Renesas Technology semiconductors are not designed or manufactured for use in a device or system that is used under circumstances in which human life is potentially at stake. Please contact Renesas Technology Corporation, Renesas Solutions Corporation or an authorized Renesas Technology product distributor when considering the use of a product contained herein for any specific purposes, such as apparatus or systems for transportation, vehicular, medical, aerospace, nuclear, or undersea repeater use.
- The prior written approval of Renesas Technology Corporation and Renesas Solutions Corporation is necessary to reprint or reproduce in whole or in part these materials.
- If these products or technologies are subject to the Japanese export control restrictions, they must be exported under a license from the Japanese government and cannot be imported into a country other than the approved destination. Any diversion or reexport contrary to the export control laws and regulations of Japan and/or the country of destination is prohibited.
- Please contact Renesas Technology Corporation or Renesas Solutions Corporation for further details on these materials or the products contained therein.

Precautions to be taken when using this product

- This product is a development supporting unit for use in your program development and evaluation stages. In mass-producing your program you have finished developing, be sure to make a judgment on your own risk that it can be put to practical use by performing integration test, evaluation, or some experiment else.
- In no event shall Renesas Solutions Corporation be liable for any consequence arising from the use of this product.
- Renesas Solutions Corporation strives to renovate or provide a workaround for product malfunction at some charge or without charge. However, this does not necessarily mean that Renesas Solutions Corporation guarantees the renovation or the provision under any circumstances.
- This product has been developed by assuming its use for program development and evaluation in laboratories. Therefore, it does not fall under the application of Electrical Appliance and Material Safety Law and protection against electromagnetic interference when used in Japan.

For inquiries about the contents of this document or product, fill in the text file the installer of the emulator debugger generates in the following directory and email to your local distributor.

\\SUPPORT\Product-name\SUPPORT.TXT

Renesas Tools Homepage <http://www.renesas.com/en/tools>

Contents

| | |
|--|----|
| Preface | 4 |
| 1. Precautions for Safety | 5 |
| 1.1 Safety Symbols and Meanings | 5 |
| 2. Handling Precautions | 9 |
| 3. Contents of the M34514T-MCU Package | 11 |
| 3.1 Things to Check When Unpacking | 11 |
| 3.2 Other Necessary Products | 11 |
| 4. M34514T-MCU | 13 |
| 4.1 Outline | 13 |
| 4.2 Specifications | 15 |
| 4.3 Description of Switches | 16 |
| 4.4 Description of Connectors | 18 |
| 4.5 Connection to the Target System | 21 |
| 4.6 LED | 27 |
| 5. Precautions to Be Taken When Debugging | 29 |
| 5.1 Reset | 29 |
| 5.2 System Clock | 29 |
| 5.3 Real-time Capability of Timer | 29 |
| 5.4 Watchdog Timer | 30 |
| 5.5 Pullup Transistor Control | 30 |
| 5.6 Port I/O Timing | 31 |
| 5.7 Port I/O Characteristics | 32 |
| 5.8 Power-down Mode | 33 |
| 5.9 Program Execution (G, GB) | 34 |
| 5.10 External Trigger Signal | 36 |
| 6. Connection Circuit Diagram | 37 |
| 7. Pitch Converter Board External Dimensions | 39 |
| 7.1 M34513T-PTCA | 39 |
| 7.2 M34513T-PTCB | 39 |
| 7.3 M34513T-PTCC | 39 |
| Appendix A. How to Request for Repair | 40 |

Preface

This user's manual describes the specifications of the M34514T-MCU emulator board for Renesas 4513/4514 Group of 4-bit single-chip microcomputers. M34514T-MCU is an MCU board for the PC4504 emulator. For the PC4504 emulator main unit and the M3T-PD45 emulator debugger, refer to each user's manual.

To use the product properly

Precautions for Safety





- In both this User's Manual and on the product itself, several icons are used to insure proper handling of this product and also to prevent injuries to you or other persons, or damage to your properties.
- The icons' graphic images and meanings are given in "Chapter 1. Precautions for Safety". Be sure to read this chapter before using the product.

Chapter 1. Precautions for Safety

In both the user's manual and on the product itself, several icons are used to insure proper handling of this product and also to prevent injuries to you or other persons, or damage to your properties.

This chapter describes the precautions which should be taken in order to use this product safely and properly. Be sure to read this chapter before using this product.

1.1 Safety Symbols and Meanings

| | | |
|---|------------------|---|
|  | WARNING | If the requirements shown in the "WARNING" sentences are ignored, the equipment may cause serious personal injury or death. |
|  | CAUTION | If the requirements shown in the "CAUTION" sentences are ignored, the equipment may malfunction. |
| | IMPORTANT | It means important information on using this product. |

In addition to the three above, the following are also used as appropriate.

△ means WARNING or CAUTION.
Example:  **CAUTION AGAINST AN ELECTRIC SHOCK**

⊘ means PROHIBITION.
Example:  **DISASSEMBLY PROHIBITED**

● means A FORCIBLE ACTION.
Example:  **UNPLUG THE POWER CABLE FROM THE RECEPTACLE.**

The following pages describe the symbols "WARNING", "CAUTION", and "IMPORTANT".

WARNING

Warning for Installation:



- Do not set this product in water or areas of high humidity. Make sure that the main unit does not get wet. Spilling water or some other liquid into the main unit can cause an unreparable damage.

Warning for Use Environment:



- This equipment is to be used in an environment with a maximum ambient temperature of 35°C. Care should be taken that this temperature is not exceeded.

CAUTION

Cautions to Be Taken for This Product:

- Do not disassemble or modify this product. Disassembling or modifying this product can cause damage. Disassembling and modifying the product will void your warranty.
- Use caution when handling the main unit. Be careful not to apply a mechanical shock.
- Do not pull the emulator probe (100-wire half-pitch cable or 50-wire normal-pitch cable) to disconnect from the emulator main unit.
- Do not use inch-size screws for this equipment. The screws used in this equipment are all ISO (meter-size) type screws. When replacing screws, use same type screws as equipped before.

IMPORTANT

Notes on Differences between Actual MCU and Emulator:

- Emulator operation differs from emulation of a mask MCU, as listed below. For details refer to "Chapter 5. Precautions to Be Taken When Debugging".
 - (1) Reset condition
 - (2) Initial values of internal resource data at power-on
 - (3) Internal ROM and RAM capacities, etc.
 - (4) Electrical characteristics
 - (5) Operation in the power-down mode
 - (6) Operation of the watchdog timer function
 - (7) Port I/O Timing
 - (8) Pullup transistor control
- Therefore, always be sure to evaluate your system with an evaluation MCU (onetime version). Also, be sure to perform board-mounted evaluation with ES (Engineering Sample) version MCU to make final confirmation of device operation before starting mask production.

Note on the Target System:

- Make sure that the target's supply voltage is + 3.0 V or + 5.0 V. Therefore the target's supply voltage should be in the range of + 3.0 V \pm 10% or + 5.0 V \pm 10%.

Notes on Connecting the Target System:

- When connecting the emulator probe, be careful to the wrong connection.
- When connecting the emulator probe, be careful to the warp of the cable. The warp may cause breaking the wire.

MEMO

2. Handling Precautions

When using the M34514T-MCU board, pay attention to the following:

(1) About the emulator

To use the M34514T-MCU board, you always need to install it on the PC4504 emulator main unit.

(2) About the MCU board installation

Before installing (and removing) the MCU board, always be sure to power off the PC4504 emulator main unit and unplug its power cord from the outlet. For details on how to install and remove the MCU board, see "Chapter 2. Setup" in the PC4504 System User's Manual.

(3) Emulator debugger (M3T-PD45)

When using the M34514T-MCU board to debug your program, you need the M3T-PD45 emulator debugger (sold separately). Be sure to use the data file for 4513 or 4514 Group included with the M3T-PD45 emulator debugger.

(4) Registers that can be operated from M3T-PD45

Table 2.1 lists the registers that can be operated from M3T-PD45 for 4514 Group MCUs. The "Yes" in the table means that the register can be operated; the "No" means that the register can not be operated.

Table 2.1 Registers that can be operated for 4514 Group MCUs

| Register | Reference | Modification | Register | Reference | Modification |
|----------|-----------|--------------|----------|-----------|--------------|
| PC | Yes | Yes | W1 | Yes | Yes |
| CY | Yes | Yes | W2 | Yes | Yes |
| A | Yes | Yes | W3 | Yes | Yes |
| B | Yes | Yes | W4 | Yes | Yes |
| X | Yes | Yes | W6 | Yes | Yes |
| Y | Yes | Yes | J1 | Yes | Yes |
| Z | Yes | Yes | Q1 | Yes | Yes |
| D | Yes | Yes | Q2 | Yes | Yes |
| E | Yes | Yes | Q3 | Yes | Yes |
| SP | Yes | No | K0 | Yes | Yes |
| V1 | Yes | Yes | PU0 | Yes | Yes |
| V2 | Yes | Yes | FR0 | No | Yes |
| I1 | Yes | Yes | MR | Yes | Yes |
| I2 | Yes | Yes | R1 | No | Yes |
| SI | Yes | Yes | R2 | No | Yes |
| LA | Yes | No | R3 | No | Yes |
| HA | Yes | Yes | R4 | No | Yes |

Table 2.2 lists the registers that can be operated from M3T-PD45 for 4513 Group MCUs. The "Yes" in the table means that the register can be operated; the "No" means that the register can not be operated.

Table 2.2 Registers that can be operated for 4513 Group MCUs

| Register | Reference | Modification | Register | Reference | Modification |
|----------|-----------|--------------|----------|-----------|--------------|
| PC | Yes | Yes | W1 | Yes | Yes |
| CY | Yes | Yes | W2 | Yes | Yes |
| A | Yes | Yes | W3 | Yes | Yes |
| B | Yes | Yes | W4 | Yes | Yes |
| X | Yes | Yes | W6 | Yes | Yes |
| Y | Yes | Yes | J1 | Yes | Yes |
| Z | Yes | Yes | Q1 | Yes | Yes |
| D | Yes | Yes | Q2 | Yes | Yes |
| E | Yes | Yes | Q3 | Yes | Yes |
| SP | Yes | No | K0 | Yes | Yes |
| V1 | Yes | Yes | PU0 | Yes | Yes |
| V2 | Yes | Yes | MR | Yes | Yes |
| I1 | Yes | Yes | R1 | No | Yes |
| I2 | Yes | Yes | R2 | No | Yes |
| SI | Yes | Yes | R3 | No | Yes |
| LA | Yes | No | R4 | No | Yes |
| HA | Yes | Yes | | | |

3. Contents of the M34514T-MCU Package

3.1 Things to Check When Unpacking

Table 3.1 shows the contents of the M34514T-MCU package. When unpacking your M34514T-MCU package, check to see that all of these components are included.

Table 3.1 Contents of M34514T-MCU

| Item | Product name | Quantity |
|------|--|----------|
| 1 | M34514T-MCU | 1 |
| 2 | 100-wire half-pitch cable (40 cm) | 1 |
| 3 | 50-wire normal-pitch cable (10 cm) | 1 |
| 4 | 2-wire cable for external trigger signal (50 cm) | 1 |
| 5 | PCA4029 pitch converter board | 1 |
| 6 | OSC-2 oscillator circuit board (J1 connector mounted) *1 | 1 |
| 7 | M34513T-PTCA pitch converter board | 1 |
| 8 | M34513T-PTCB pitch converter board | 1 |
| 9 | M34513T-PTCC pitch converter board *2 | 1 |
| 10 | M34514T-MCU English user's manual (this manual) | 1 |

*1 M34514T-MCU has an oscillator circuit board OSC-2 (for 4.19 MHz) that is incorporated when shipped from the factory. In addition, it comes with an oscillator circuit board OSC-2, with only a connector J1 mounted.

*2 M34513T-PTCC consists of M34513T-PTCC and TQPACK.

*3 Keep the packaging carton and cushion material of the M34514T-MCU to transport it for repair or for other purposes in the future.

*4 If you find any item missing or faulty, or any suggestion, contact your local distributor.

3.2 Other Necessary Products

To bring forward programs development on the 4513/4514 Group of 4-bit microcomputers, the products given below are necessary in addition to those contained in the package above. Get them separately to be ready when necessary.

- (1) Emulator main unit: PC4504
- (2) Emulator debugger: M3T-PD45
- (3) Programming adapter: PCA7441 (for 4514 Group SSOP)
PCA7442FP (for 4513 Group LQFP)
PCA7442SP (for 4513 Group SDIP)

MEMO

4. M34514T-MCU

4.1 Outline

By using with the PC4504 emulator main unit, M34514T-MCU can make up an emulator system which can be operated by a personal computer.

Figure 4.1 shows the development support system configuration for 4514 Group MCUs.

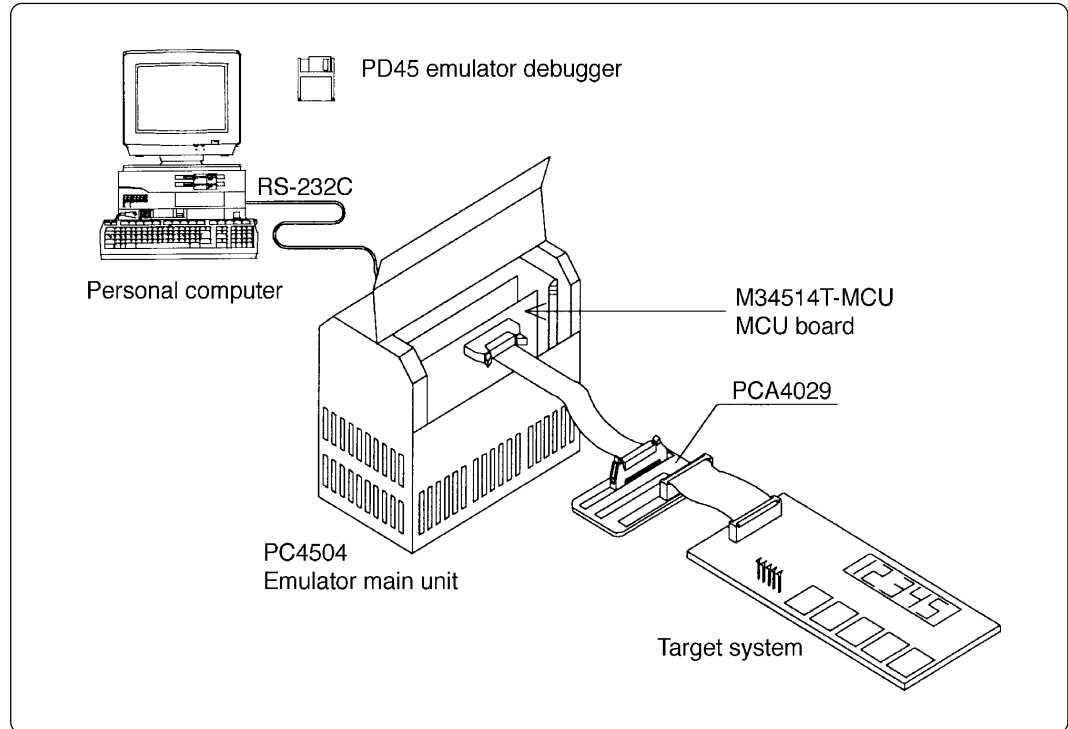

Figure 4.1 Development support system configuration for 4514 Group MCUs

Figure 4.2 shows the development support system configuration for 4513 Group MCUs.

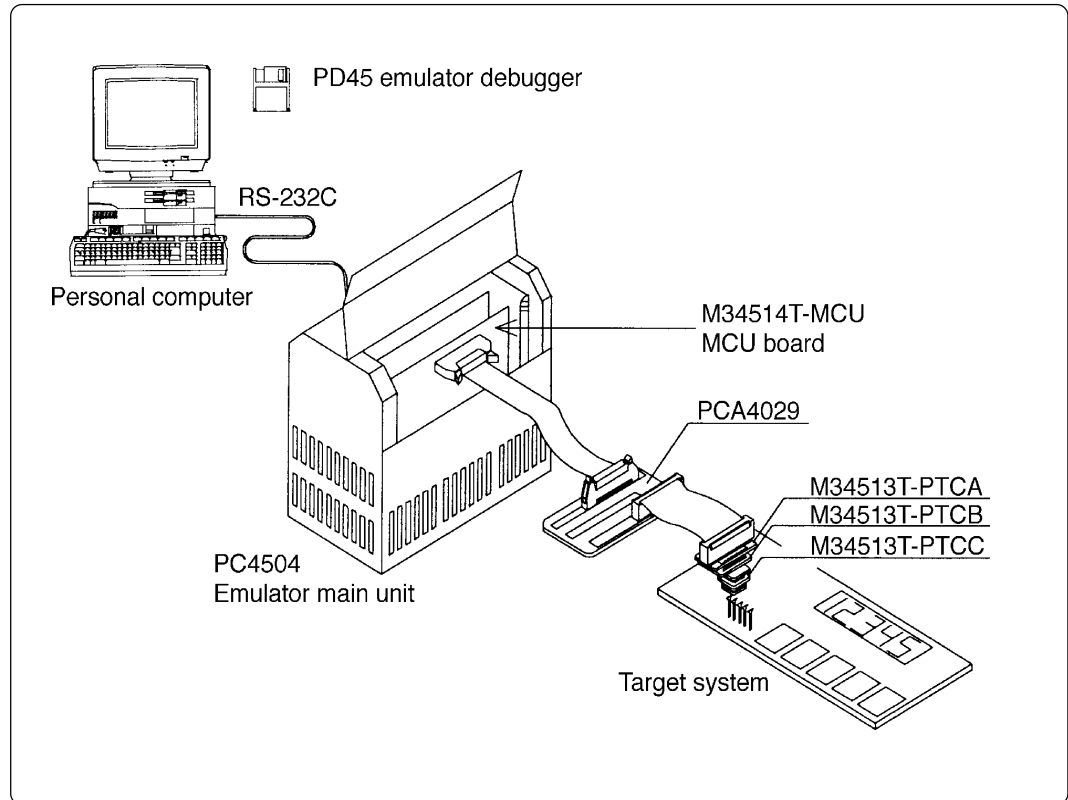

Figure 4.2 Development support system configuration for 4513 Group MCUs

*1 Use the M34513T-PTCA pitch converter board for 32SDIP.

*2 Use the M34513T-PTCA, M34513T-PTCB and M34513T-PTCC pitch converter boards for 32LQFP.

For more details, refer to "4.5 Connection to the Target System".

4.2 Specifications

Table 4.1 lists specifications of M34514T-MCU.

Table 4.1 M34514T-MCU Specifications

| | | | | |
|-----------------------------------|--|----------------------|--------------|-----------------------------------|
| Applicable MCUs | M34513MX-XXXFP/SP, M34513EX-XXXFP/SP | | | |
| | M34514MX-XXXFP, M34514E8-XXXFP | | | |
| Evaluation MCU | M34514E8FP (mounted) | | | |
| Maximum operating clock frequency | 3 V | Medium-speed mode*1: | 4.2 MHz | |
| | | High-speed mode: | 2.0 MHz | |
| | 5 V | Medium-speed mode*1: | 4.2 MHz | |
| | | High-speed mode: | 4.2 MHz | |
| Target system voltage | 3 V or 5 V | | | |
| Power supply | Supplied by the PC4504's internal power supply (+5 V, +12 V) | | | |
| Port emulation | Port | Output type | Direction | Device used |
| | D ₀ to D ₅ | N-channel open drain | Input/output | Input: 74HC4050 Output: 74LS06 |
| | P0 ₀ to P0 ₃ | | | |
| | P1 ₀ to P1 ₃ | | | |
| | P2 ₁ /S _{OUT} | | | Input/Output: 74HC4066 |
| | P2 ₂ /S _{IN} | - | Input | Input: 74HC4050 |
| Board dimensions | 233 (L) x 135 (W) x 26 (H) mm | | | |
| Operating temperature | 5 to 35°C (non-condensing) | | | |
| Product configuration | M34514T-MCU 100-wire half-pitch cable 50-wire normal-pitch cable External trigger cable PCA4029 OSC-2 (for changing frequencies) *2 M34513T-PTCA M34513T-PTCB M34513T-PTCC*3 | | | |

*1 M34514T-MCU operates at the medium-speed mode (instruction-clock $f(X_{IN})/6$) immediately after a RESET is released.

*2 M34514T-MCU has an oscillator circuit board OSC-2 (for 4.19 MHz) that is incorporated when shipped from the factory. In addition, it comes with an oscillator circuit board OSC-2, with only a connector J1 mounted.

*3 M34513T-PTCC consists of M34513T-PTCC and TQPACK.

4.3 Description of Switches

The M34514T-MCU board has eight switches. Figure 4.3 shows the positions of these switches. Tables 4.2 and 4.3 list the functions of the switches and the preset switch positions that are set before the MCU board is shipped from the factory.

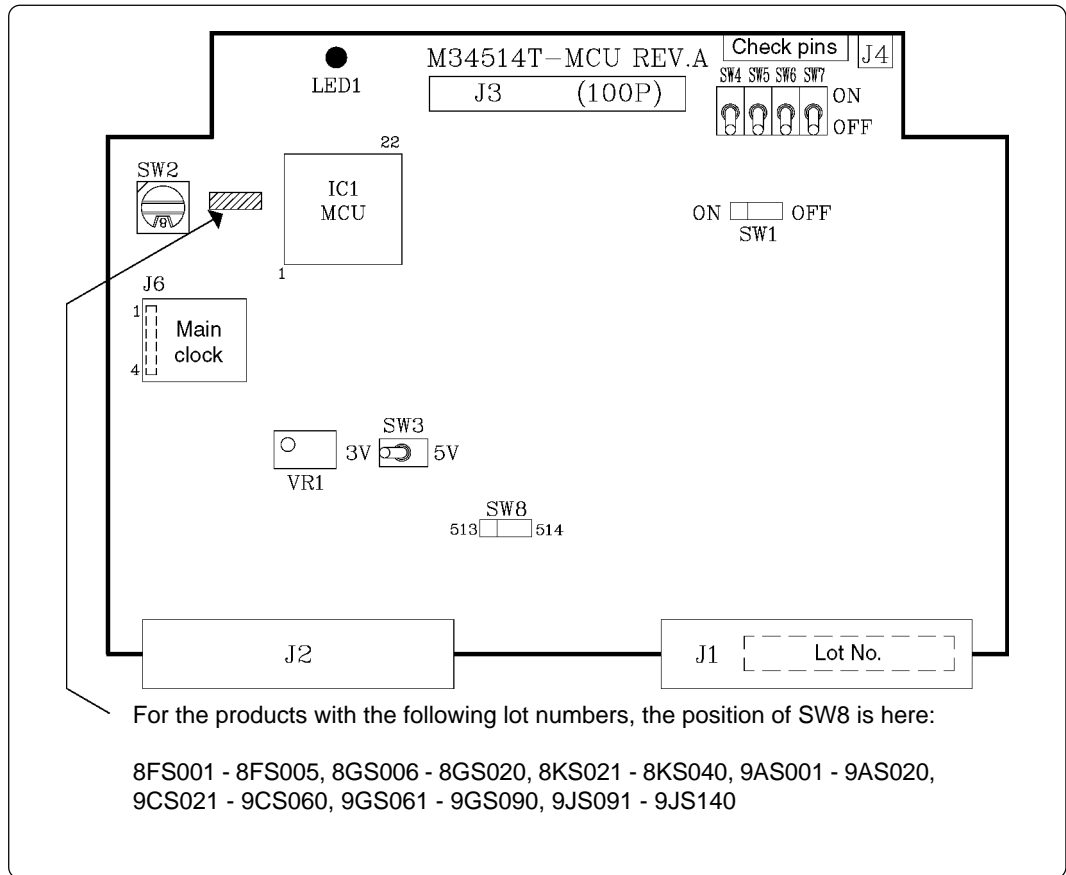

Figure 4.3 Positions of switches

Table 4.2 Functions of switches (1/2)













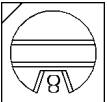
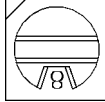

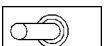
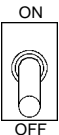
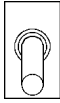
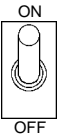
| Label | Switch position | Description | Factory-setting |
|-------|--|--|--|
| SW1 | OFF ON  | Does not connect the V _{DD} of the M34514T-MCU to the V _{DD} of the target system. |  OFF |
| | ON ON  | Connects the V _{DD} of the M34514T-MCU to the V _{DD} of the target system. | |
| SW2 | ROMSIZE  | Set the MCU's ROM size. • Set "2" (M2) • Set "4" (M4) • Set "6" (M6) • Set "8" (M8) |  8 |
| SW3 | 5 V 3V  | Operates the target MCU at +5 V. |  5V |
| | 3 V 3V  | Operates the target MCU at + 3 V. | |

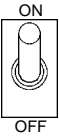
Table 4.3 Functions of switches (2/2)

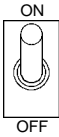
| Label | | Switch position | Description | Factory-setting |
|-------|-----|---|---|--|
| SW4 | OFF |  | Does not connect the pullup resistor 68 kΩ to the ports P0 ₀ and P0 ₁ . |  OFF |
| | ON |  | Connects the pullup resistor 68 kΩ to the ports P0 ₀ and P0 ₁ . | |
| SW5 | OFF |  | Does not connect the pullup resistor 68 kΩ to the ports P0 ₂ and P0 ₃ . |  OFF |
| | ON |  | Connects the pullup resistor 68 kΩ to the ports P0 ₂ and P0 ₃ . | |
| SW6 | OFF |  | Does not connect the pullup resistor 68 kΩ to the ports P1 ₀ and P1 ₁ . |  OFF |
| | ON |  | Connects the pullup resistor 68 kΩ to the ports P1 ₀ and P1 ₁ . | |
| SW7 | OFF |  | Does not connect the pullup resistor 68 kΩ to the ports P1 ₂ and P1 ₃ . |  OFF |
| | ON |  | Connects the pullup resistor 68 kΩ to the ports P1 ₂ and P1 ₃ . | |
| SW8 | 514 |  | Operates for 4514 Group. |  514 |
| | 513 |  | Operates for 4513 Group. | |

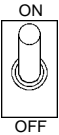
4.4 Description of Connectors

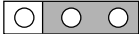
The M34514T-MCU board has five connectors. Table 4.4 lists the functions of these connectors. Figure 4.4 shows the positions of connectors on the MCU board.

Table 4.4 Connectors

| Connector | Function |
|-----------|--|
| J1 | Connects the evaluation MCU bus. |
| J2 | Connects the monitor CPU bus. |
| J3 | Connects the target system. (100-pin) |
| J4 | Connects the external trigger signal. (2-pin) |
| J6 | Connects the oscillator circuit board. (4-pin) |

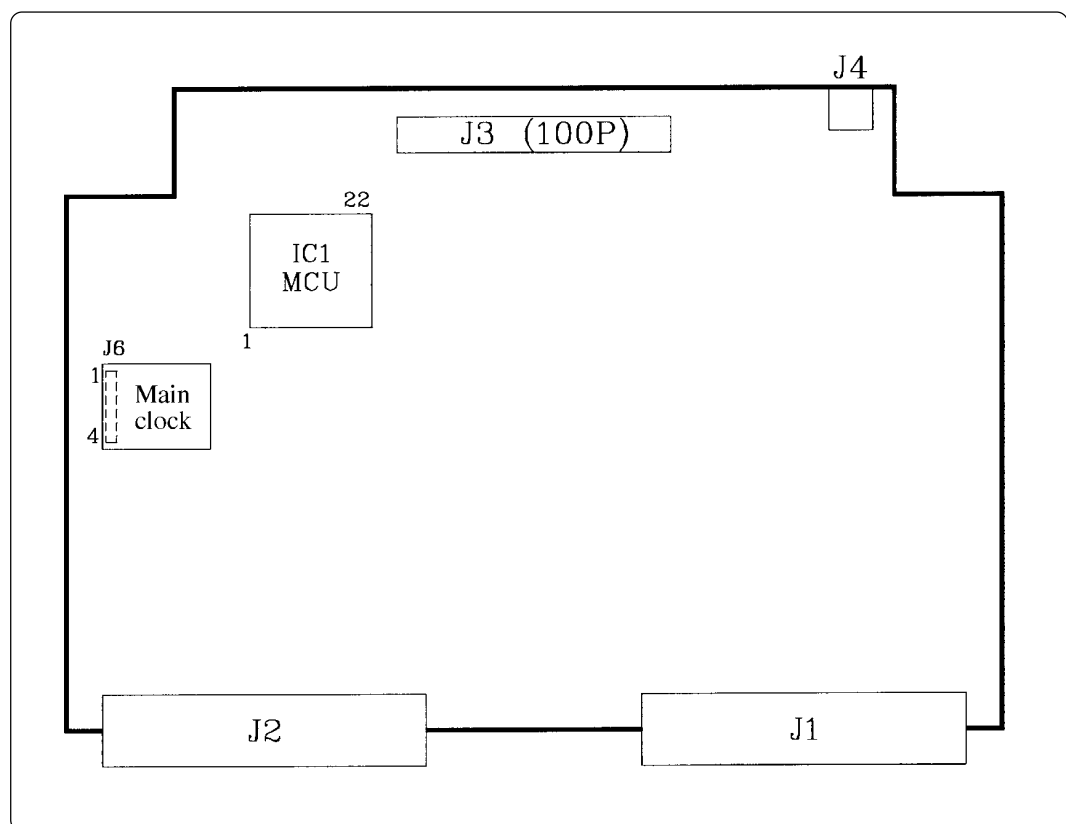

Figure 4.4 Positions of the connectors

(1) Connector J3

Table 4.5 lists the pin assignments of the 100-wire half-pitch connector (J3) for connecting the PCA4029. And Figure 4.5 shows the connector J3 pin layout.

Table 4.5 Pin assignments of the connector J3

| Line A | | | Line B | | | Line C | | | Line D | | |
|---------|--------|-----|---------|--------|-----|---------|-----------------------------------|-----|---------|-----------------------------------|-----|
| Pin No. | Signal | I/O | Pin No. | Signal | I/O | Pin No. | Signal | I/O | Pin No. | Signal | I/O |
| 1 | GND | | 1 | GND | | 1 | EP1 ₃ | I/O | 1 | EP1 ₂ | I/O |
| 2 | GND | | 2 | GND | | 2 | ED ₀ | I/O | 2 | EP1 ₁ | I/O |
| 3 | GND | | 3 | GND | | 3 | ED ₁ | I/O | 3 | EP1 ₀ | I/O |
| 4 | GND | | 4 | GND | | 4 | ED ₂ | I/O | 4 | EP0 ₃ | I/O |
| 5 | GND | | 5 | GND | | 5 | ED ₃ | I/O | 5 | EP0 ₂ | I/O |
| 6 | GND | | 6 | GND | | 6 | ED ₄ | I/O | 6 | EP0 ₁ | I/O |
| 7 | GND | | 7 | GND | | 7 | ED ₅ | I/O | 7 | EP0 ₀ | I/O |
| 8 | GND | | 8 | GND | | 8 | D ₆ /CNTR0 | I/O | 8 | P4 ₃ /A _{IN7} | I/O |
| 9 | GND | | 9 | GND | | 9 | D ₇ /CNTR1 | I/O | 9 | P4 ₂ /A _{IN6} | I/O |
| 10 | GND | | 10 | GND | | 10 | P5 ₀ | I/O | 10 | P4 ₁ /A _{IN5} | I/O |
| 11 | GND | | 11 | GND | | 11 | P5 ₁ | I/O | 11 | P4 ₀ /A _{IN4} | I/O |
| 12 | GND | | 12 | GND | | 12 | P5 ₂ | I/O | 12 | A _{IN3} /COM1+ | I |
| 13 | GND | | 13 | GND | | 13 | P5 ₃ | I/O | 13 | A _{IN2} /COM1- | I |
| 14 | GND | | 14 | GND | | 14 | P2 ₀ /S _{CK} | I/O | 14 | A _{IN1} /COM0+ | I |
| 15 | GND | | 15 | GND | | 15 | P2 ₁ /S _{OUT} | I/O | 15 | A _{IN0} /COM0- | I |
| 16 | GND | | 16 | GND | | 16 | P2 ₂ /S _{IN} | I | 16 | P3 ₃ | I/O |
| 17 | GND | | 17 | GND | | 17 | RESET | I | 17 | P3 ₂ | I/O |
| 18 | GND | | 18 | GND | | 18 | CNV _{SS} | - | 18 | P3 ₁ /INT1 | I/O |
| 19 | GND | | 19 | GND | | 19 | X _{OUT} | - | 19 | P3 ₀ /INT0 | I/O |
| 20 | GND | | 20 | GND | | 20 | X _{IN} | - | 20 | VDCE | I |
| 21 | GND | | 21 | GND | | 21 | V _{SS} | | 21 | V _{DD} | |
| 22 | GND | | 22 | GND | | 22 | NC | - | 22 | NC | - |
| 23 | GND | | 23 | GND | | 23 | NC | - | 23 | NC | - |
| 24 | GND | | 24 | GND | | 24 | NC | - | 24 | NC | - |
| 25 | GND | | 25 | GND | | 25 | NC | - | 25 | NC | - |

Note: "I" in the direction column denotes "Input"; "O" denotes "Output"; "I/O" denotes "Input/output"; "-" denotes "Not connected".

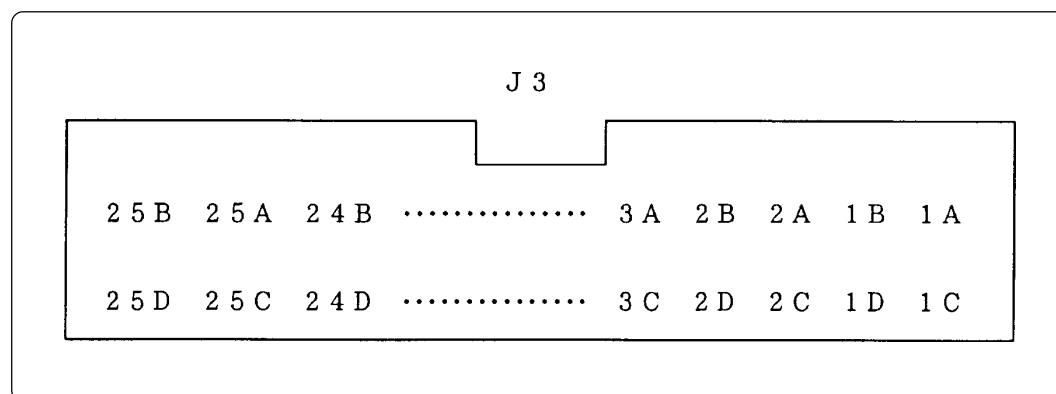

Figure 4.5 Connector J3 pin layout

(2) Connector J4

To use the external trigger signal as event input of trigger breaks or trace points, connect the 2-wire external trigger signal cable included with your M34514T-MCU board to the connector J4. Connect the black clip of the external trigger cable to GND, and use the white clip for external trigger signal input. Table 4.6 lists the pin assignments of the connector J4.

Table 4.6 Pin assignments of connector J4

| Pin No. | Signal | Function |
|---------|--------|-------------------------------|
| 1 | TRIG | External trigger signal input |
| 2 | GND | GND input |

(3) Connector J6

The connector J6 is a connector used to connect an oscillator circuit board OSC-2. Table 4.7 lists the pin assignments of the connector J6. Figure 4.6 shows the pin layout of the connector J6. For the 4.19 MHz operation with the oscillator circuit board OSC-2, see Figure 4.7.

Table 4.7 Pin assignments of connector J6

| Pin No. | Signal | Function |
|---------|-----------------|--------------|
| 1 | V _{cc} | Power supply |
| 2 | GND | GND |
| 3 | CLK | Clock input |
| 4 | GND | GND |

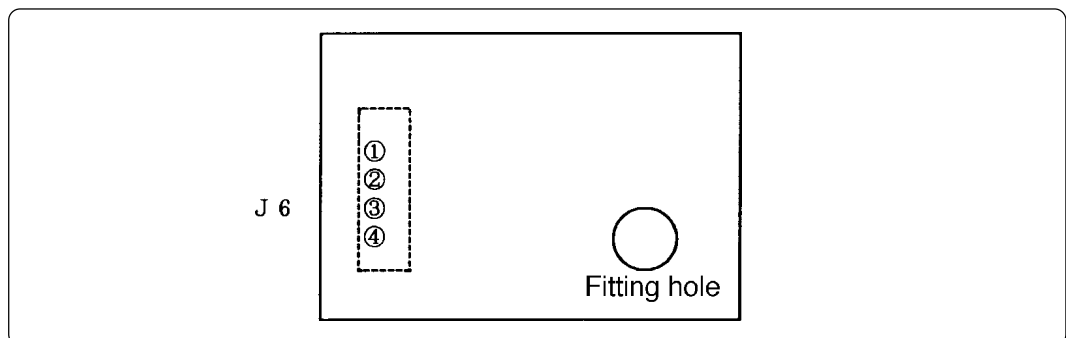

Figure 4.6 Pin layout of connector J6

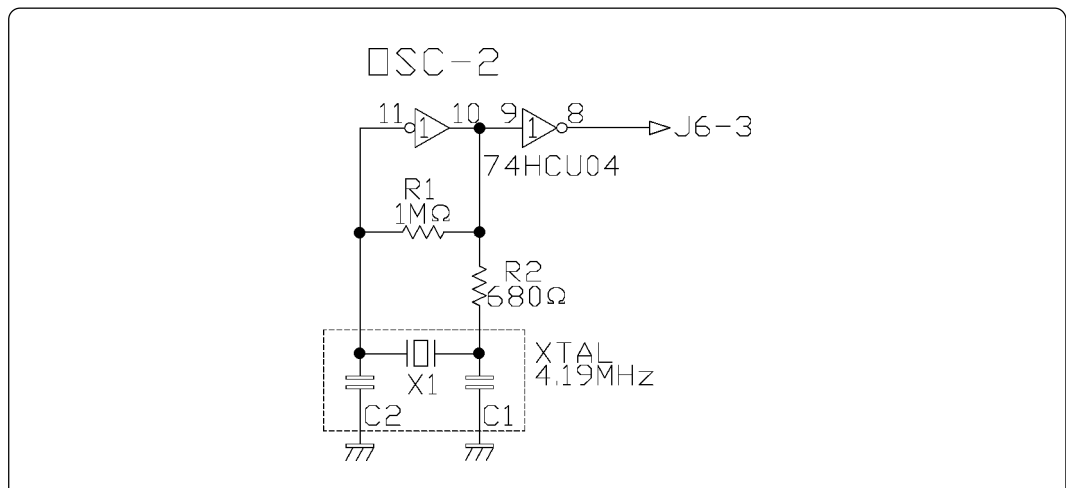

Figure 4.7 Circuit diagram of OSC-2 oscillator circuit board (4.19 MHz)

4.5 Connection to the Target System

(1) For 4514 Group

When connecting the M34514T-MCU board to the target system:

a. Connecting to 2.54-mm-pitch Dual-in-line Pins on the Target System

Use the 50-wire normal-pitch cable (included) to connect the 50-pin dual-in-line pins on the target system. Following products are required for connection to the target system.

- 100-wire half-pitch cable (40 cm)
- PCA4029 pitch converter board
- 50-wire normal-pitch cable (10 cm)

Figure 4.8 depicts the M34514T-MCU board connected to the target system using the 50-wire normal-pitch cable. Table 4.8 lists the connector signal assignments of the 50-wire normal-pitch cable. Figure 4.9 shows the pin layout of the 50-wire normal-pitch cable.

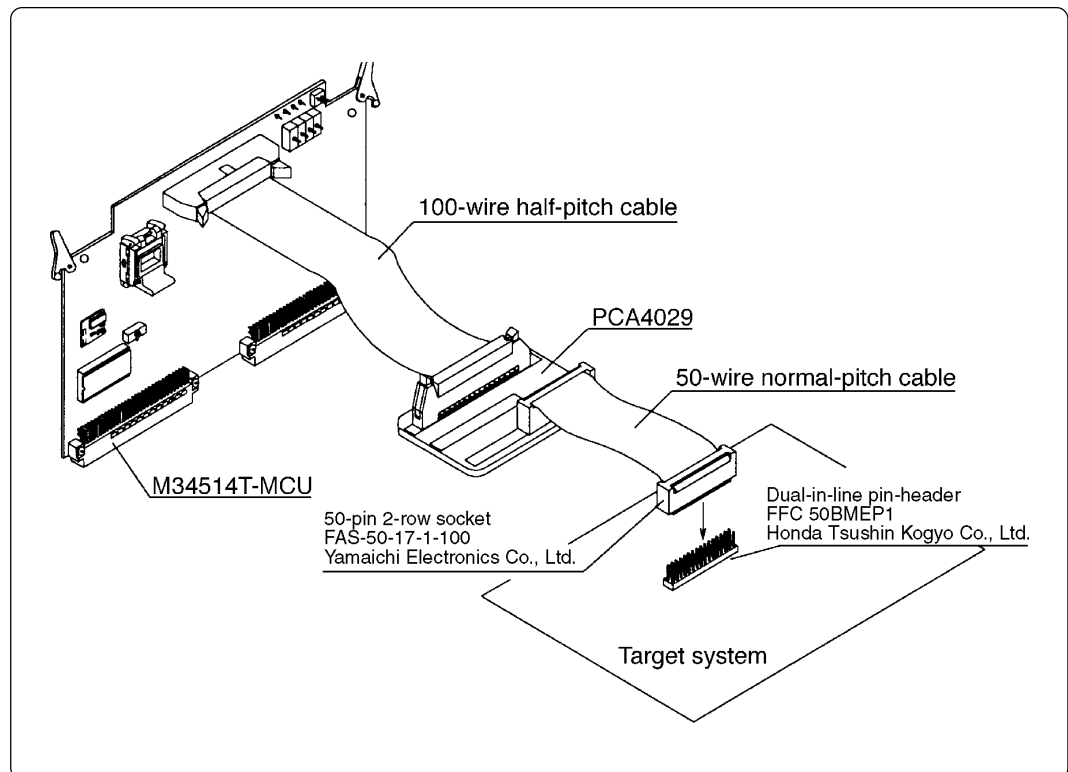

Figure 4.8 Connection to the target system using dual-in-line pins

Table 4.8 50-wire normal-pitch cable pin assignments

| 50-wire normal-pitch cable | | | |
|----------------------------|-----------------------------------|---------|-----------------------------------|
| Pin No. | Signal | Pin No. | Signal |
| 1 | EP1 ₃ | 50 | EP1 ₂ |
| 2 | ED ₀ | 49 | EP1 ₁ |
| 3 | ED ₁ | 48 | EP1 ₀ |
| 4 | ED ₂ | 47 | EP0 ₃ |
| 5 | ED ₃ | 46 | EP0 ₂ |
| 6 | ED ₄ | 45 | EP0 ₁ |
| 7 | ED ₅ | 44 | EP0 ₀ |
| 8 | D ₆ /CNTR0 | 43 | P4 ₃ /A _{IN7} |
| 9 | D ₇ /CNTR1 | 42 | P4 ₂ /A _{IN6} |
| 10 | P5 ₀ | 41 | P4 ₁ /A _{IN5} |
| 11 | P5 ₁ | 40 | P4 ₀ /A _{IN4} |
| 12 | P5 ₂ | 39 | A _{IN3} /COM1+ |
| 13 | P5 ₃ | 38 | A _{IN2} /COM1- |
| 14 | P2 ₀ /S _{CK} | 37 | A _{IN1} /COM0+ |
| 15 | P2 ₁ /S _{OUT} | 36 | A _{IN0} /COM0- |
| 16 | P2 ₂ /S _{IN} | 35 | P3 ₃ |
| 17 | RESET | 34 | P3 ₂ |
| 18 | NC (CNV _{SS}) | 33 | P3 ₁ /INT1 |
| 19 | NC (X _{OUT}) | 32 | P3 ₀ /INT0 |
| 20 | NC (X _{IN}) | 31 | VDCE |
| 21 | V _{SS} | 30 | V _{DD} |
| 22 | NC | 29 | NC |
| 23 | NC | 28 | NC |
| 24 | NC | 27 | NC |
| 25 | NC | 26 | NC |

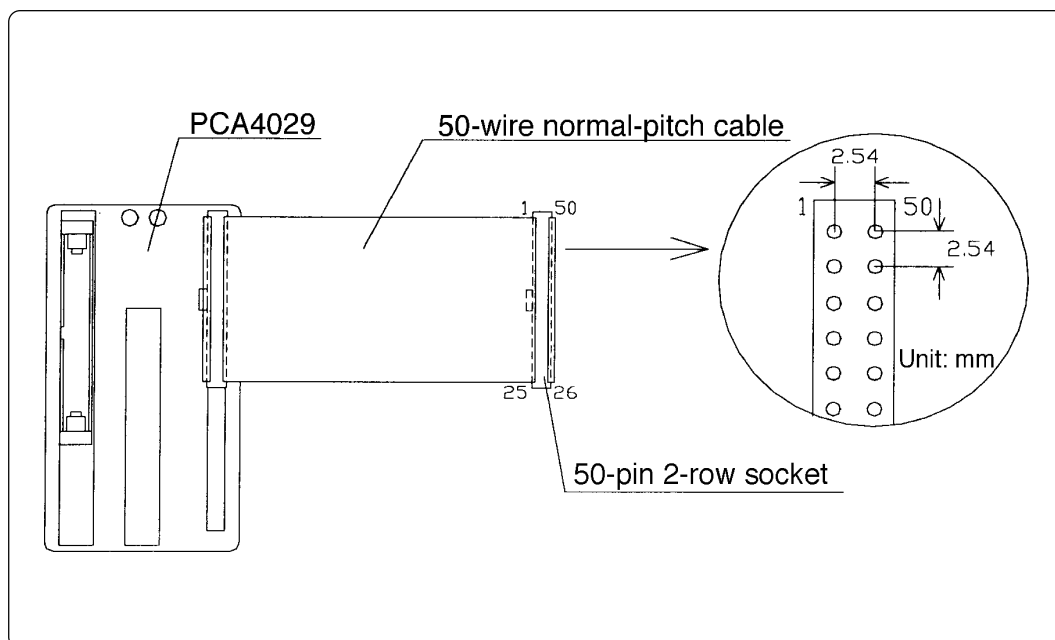

Figure 4.9 Pin layout of 50-wire normal-pitch cable

(2) For 4513 Group

When connecting the M34514T-MCU board to the target system (for 4513 Group):

a. Connecting to the IC socket for 32-pin SDIP on the Target System

Connect the M34514T-MCU board with the IC socket for 32-pin SDIP on the target system using the 50-wire normal-pitch cable (included) with the M34513T-PTCA pitch converter board attached. Figure 4.10 depicts the connection between the M34513T-PTCA pitch converter board and the target system. Following products are required for connection to the target system.

- 100-wire half-pitch cable (40 cm)
- PCA4029 pitch converter board
- 50-wire normal-pitch cable (10 cm)
- M34513T-PTCA pitch converter board

Table 4.9 shows the connector signal assignments of the M34513T-PTCA pitch converter board. The pin assignments of M34513T-PTCA is the same as for the 32SDIP in 4513 Group. When connecting the M34513T-PTCA pitch converter board, make sure the No. 1 pin position of each connector is aligned with that of cable. To avoid damage to the emulator and target system, be careful of the connection.

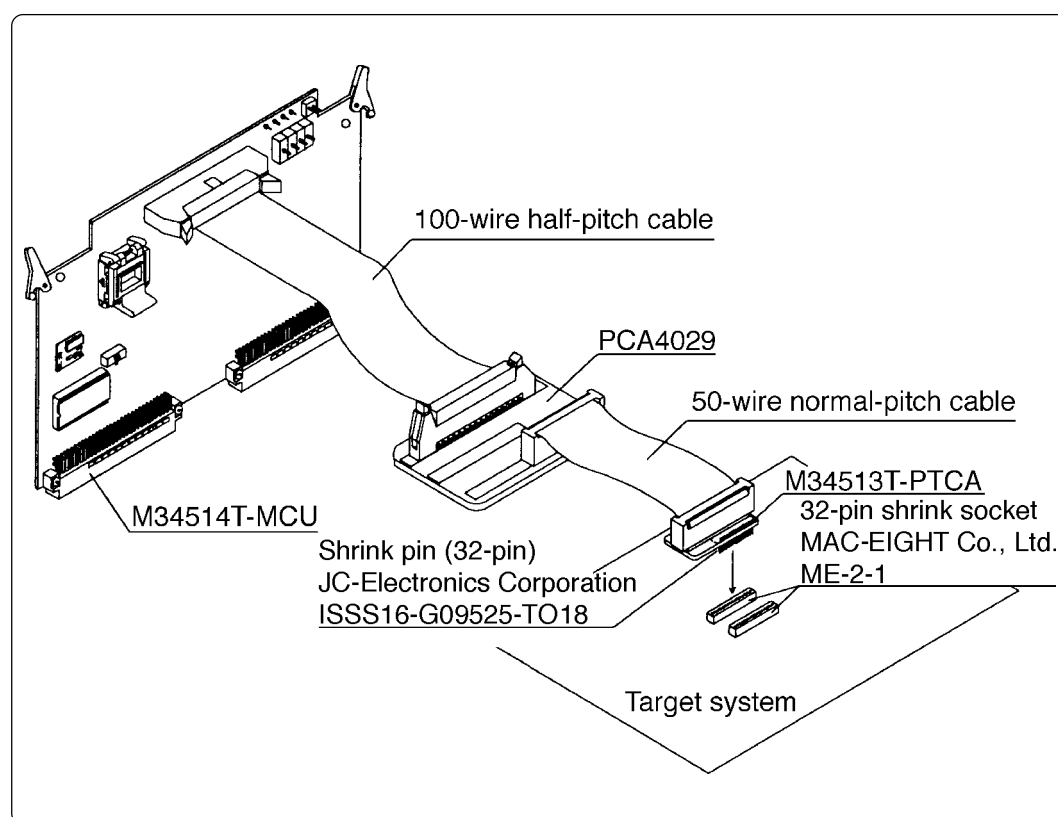

Figure 4.10 Connecting to IC socket for 32-pin SDIP

Table 4.9 M34513T-PTCA pin assignments

| M34513T-PTCA J2 | | | |
|-----------------|-----------------------------------|---------|-------------------------|
| Pin No. | Signal | Pin No. | Signal |
| 1 | ED ₀ | 32 | EP1 ₃ |
| 2 | ED ₁ | 31 | EP1 ₂ |
| 3 | ED ₂ | 30 | EP1 ₁ |
| 4 | ED ₃ | 29 | EP1 ₀ |
| 5 | ED ₄ | 28 | EP0 ₃ |
| 6 | ED ₅ | 27 | EP0 ₂ |
| 7 | D ₆ /CNTR0 | 26 | EP0 ₁ |
| 8 | D ₇ /CNTR1 | 25 | EP0 ₀ |
| 9 | P2 ₀ /S _{CK} | 24 | A _{IN3} /COM1+ |
| 10 | P2 ₁ /S _{OUT} | 23 | A _{IN2} /COM1- |
| 11 | P2 ₂ /S _{IN} | 22 | A _{IN1} /COM0+ |
| 12 | RESET | 21 | A _{IN0} /COM0- |
| 13 | CNV _{SS} | 20 | P3 ₁ /INT1 |
| 14 | X _{OUT} | 19 | P3 ₀ /INT0 |
| 15 | X _{IN} | 18 | VDCE |
| 16 | V _{SS} | 17 | V _{DD} |

b. When Connecting to a 32-pin LQFP Foot Pattern on the Target System

Attach the pitch converter boards M34513T-PTCA and M34513T-PTCB to the 50-pin normal-pitch cable (included with this product). Then connect the cable via the M34513T-PTCC to the TQPACK032SA that has been soldered to the 32-pin LQFP foot pattern on the target system. Figure 4.11 shows an example of how to connect to the target system using the M34513T-PTCA, M34513T-PTCB, and M34513T-PTCC. Following products are required for connection to the target system:

- 100-wire half-pitch cable (40 cm)
- PCA4029 pitch converter board
- 50-wire normal-pitch cable (10 cm)
- M34513T-PTCA pitch converter board
- M34513T-PTCB pitch converter board
- M34513T-PTCC pitch converter board (TQPACK* included)

* TQPACK consists of TQSOCKET032AF, TQSOCKET032SAP and TQPACK032SA.

Table 4.10 shows the connector signal assignments of the TQPACK032SA. When the TQPACK032SA and M34513T-PTCC are used for target system connection, the pin assignments are the same as for the 32LQFP in 4513 Group.

Solder the TQPACK032SA to the 32-pin LQFP foot pattern on the target system. The No. 1 pin of the TQPACK032SA is located at its corner-cut part of package. Attach the M34513T-PTCC to the TQPACK032SA with its No. 1 pin position (marked by a white dot) aligned with that of the TQPACK032SA. After attaching the pitch converter boards M34513T-PTCA and M34513T-PTCB to the 50-pin normal-pitch cable, connect the cable to the M34513T-PTCC. To avoid damage to the emulator and target system, be careful of the connection.

When connecting cable and attaching the pitch converter boards, make sure the No. 1 pin position of each connector is aligned with that of cable. Figure 4.12 shows the external view of the TQPACK032SA and M34513T-PTCC.

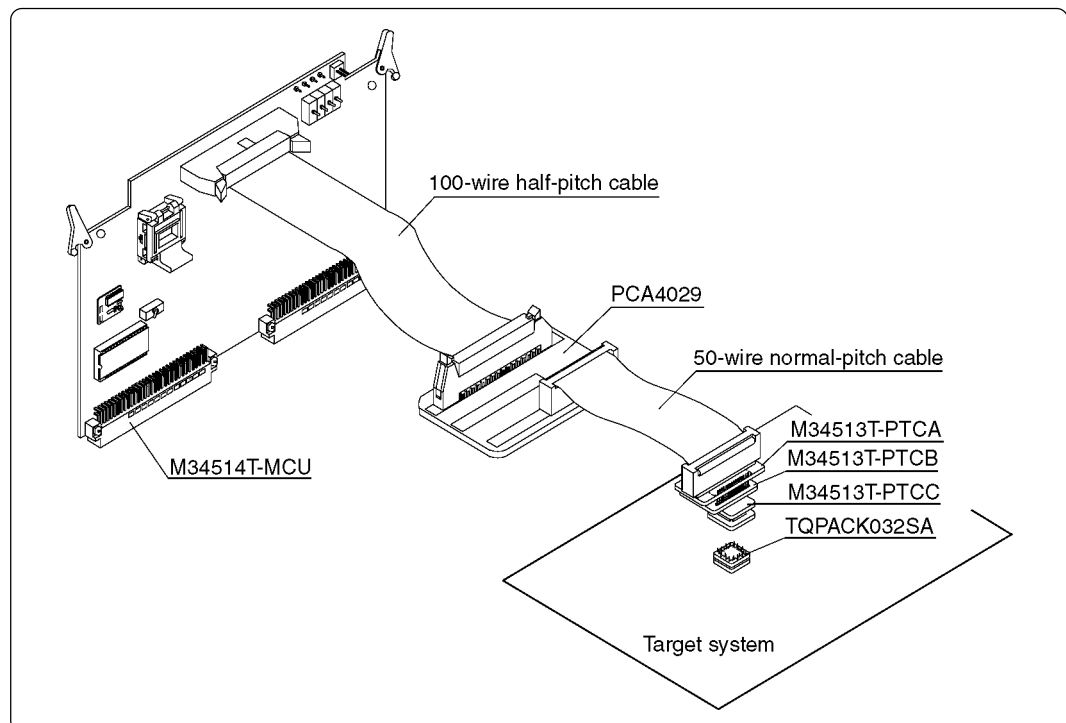

Figure 4.11 Connecting to 32-pin LQFP foot pattern on target system

Table 4.10 TQPACK032SA pin assignments

| TQPACK pin No. | | | |
|----------------|-----------------------------------|---------|-------------------------|
| Pin No. | Signal | Pin No. | Signal |
| 1 | ED ₃ | 32 | ED ₂ |
| 2 | ED ₄ | 31 | ED ₁ |
| 3 | ED ₅ | 30 | ED ₀ |
| 4 | D ₆ /CNTR0 | 29 | EP1 ₃ |
| 5 | D ₇ /CNTR1 | 28 | EP1 ₂ |
| 6 | P2 ₀ /SCK | 27 | EP1 ₁ |
| 7 | P2 ₁ /S _{OUT} | 26 | EP1 ₀ |
| 8 | P2 ₂ /S _{IN} | 25 | EP0 ₃ |
| 9 | $\overline{\text{RESET}}$ | 24 | EP0 ₂ |
| 10 | CNV _{SS} | 23 | EP0 ₁ |
| 11 | X _{OUT} | 22 | EP0 ₀ |
| 12 | X _{IN} | 21 | A _{IN3} /COM1+ |
| 13 | V _{SS} | 20 | A _{IN2} /COM1- |
| 14 | V _{DD} | 19 | A _{IN1} /COM0+ |
| 15 | VDCE | 18 | A _{IN0} /COM0- |
| 16 | P3 ₀ /INT0 | 17 | P3 ₁ /INT1 |

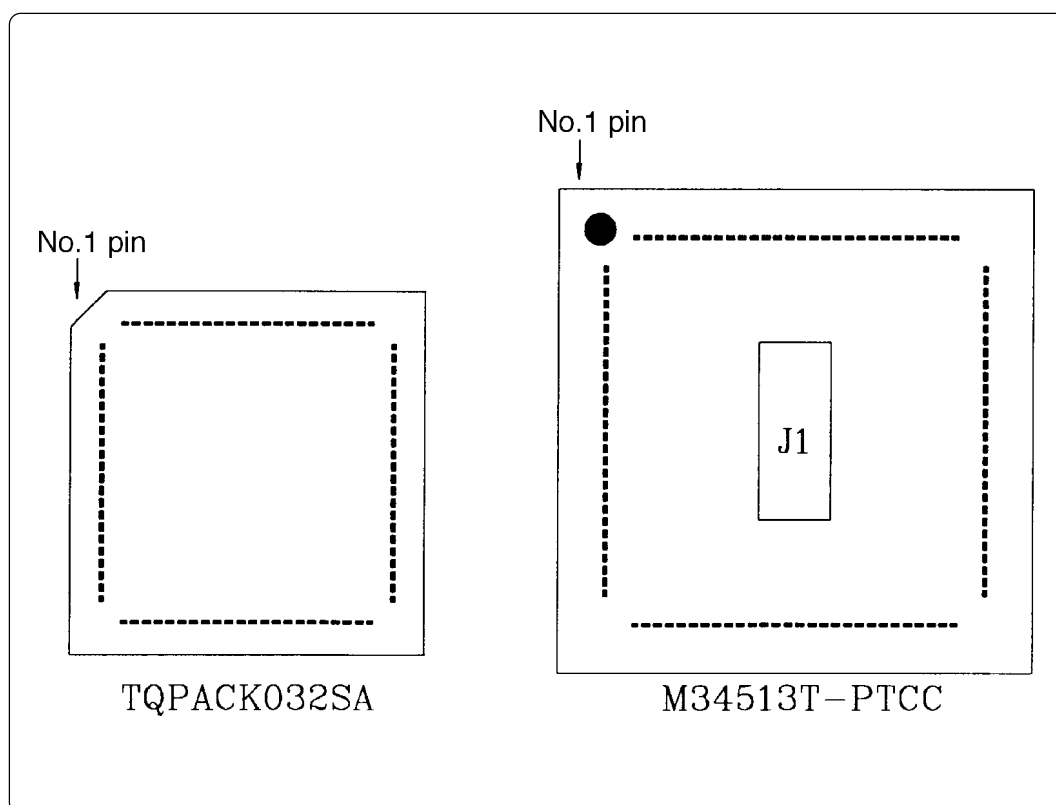

Figure 4.12 External view of TQPACK032SA and M34513T-PTCC

Some signals connected to the target system are emulated on the M34514T-MCU board. For details, see "Chapter 6. Connection Circuit Diagram".

(1) Pins connected directly to the target system (8 types, 21 lines)

- P3₀ to P3₃*1
- P4₀to P4₃*1
- P5₀to P5₃*1
- P2₀
- D₆, D₇
- A_{IN0}to A_{IN3}
- VDCE
- V_{SS}

*1 For 4513 Group MCUs, the ports P3₂, P3₃, P4₀to P4₃and P5₀to P5₃can not be connected to the target system.

(2) Pins connected to the target system via emulation circuits etc. (6 types, 18 lines)

- P0₀to P0₃
- P1₀to P1₃
- P2₁to P2₂
- D₀to D₅
- RESET*
- V_{DD}

(3) Pins not connected to the target system (3 types, 3 lines)

- X_{IN}
- X_{OUT}
- CNV_{SS}

4.6 LED

Figure 4.13 shows the LED layout of M34514T-MCU. The LED lights in green when the power is supplied to the MCU board.

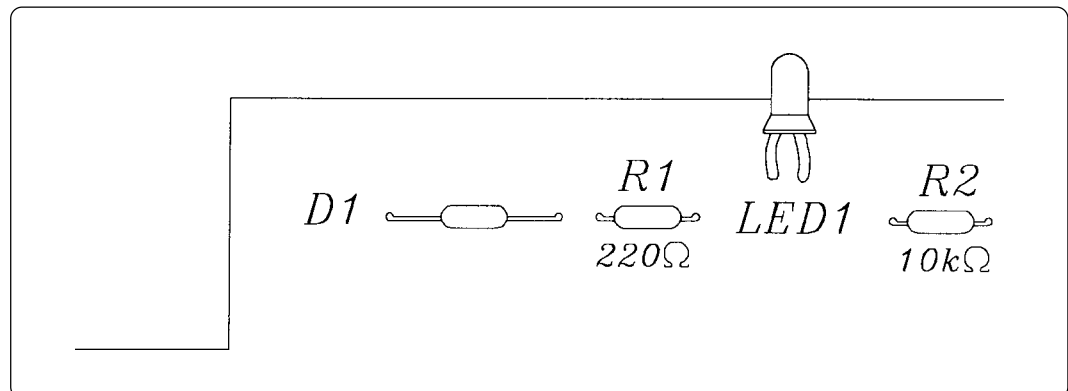

Figure 4.13 Layout of LED

MEMO

5. Precautions to Be Taken When Debugging

5.1 Reset

The M34514T-MCU uses a 74AC14 for its RESET signal input buffer, so that its electrical characteristics differ from those of the actual chip. Table 5.1 lists the RESET signal input characteristics of the M34514T-MCU.

Table 5.1 RESET signal input characteristics

| Item | Symbol | Voltage | Minimum | Maximum |
|---------------------------|--------|-------------------------|---------|---------|
| H-level threshold voltage | V_P | $V_{CC} = 3.0\text{ V}$ | - | 2.2 V |
| | | $V_{CC} = 4.5\text{ V}$ | - | 3.2 V |
| | | $V_{CC} = 5.5\text{ V}$ | - | 3.9 V |
| L-level threshold voltage | V_N | $V_{CC} = 3.0\text{ V}$ | 0.5 V | - |
| | | $V_{CC} = 4.5\text{ V}$ | 0.9 V | - |
| | | $V_{CC} = 5.5\text{ V}$ | 1.1 V | - |
| Hysteresis voltage | V_H | $V_{CC} = 3.0\text{ V}$ | 0.3 V | 1.2 V |
| | | $V_{CC} = 4.5\text{ V}$ | 0.4 V | 1.4 V |
| | | $V_{CC} = 5.5\text{ V}$ | 0.5 V | 1.6 V |

5.2 System Clock

Depending on the supply voltage and operation mode, use one of the following frequencies for the system clock:

- Supply voltage 5 V: 4.2 MHz or less (medium-speed/high-speed mode)
- Supply voltage 3 V: 4.2 MHz or less (medium-speed mode), 2.0 MHz or less (high-speed mode)

To change this clock frequency to suit that of the target system, attach the necessary parts to the oscillator circuit board OSC-2 that are included with the M34514T-MCU package.

For details about the oscillation circuit constant, consult your oscillator manufacturer.

5.3 Real-time Capability of Timer

The PC4504 and M34514T-MCU have their internal clock operating even during emulation, so that the timer values keep changing.

- Example:
- (1) When single-stepping the program
 - (2) When registers or internal RAM are referenced or modified

5.4 Watchdog Timer

The M34514T-MCU does not have an operational watchdog timer. Therefore, use an evaluation MCU (OTP version) to verify the operation associated with a watchdog timer.

The M34514T-MCU outputs a signal whose waveform is shown below from the check pin TP5 during WRST instruction execution cycles. This signal allows you to check the initialization cycle of a watchdog timer.

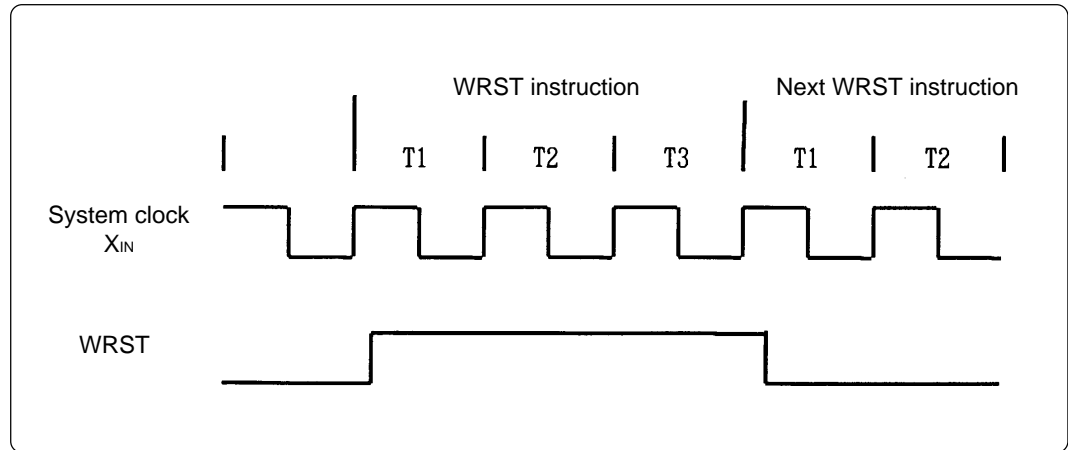

Figure 5.1 Waveform output from check pin TP5

5.5 Pullup Transistor Control

Since ports P₀ and P₁ contain emulation circuits, you can not control the pullup resistors using the pullup control register PU0. If you want to use the internal pullup resistors, turn on switches SW4 to SW7 to activate the pullup resistors on the M34514T-MCU board.

The port's resistance value of the pullup resistor (RA1) is 68 k Ω .

5.6 Port I/O Timing

(1) Port input timing

Port input timings are the same as with the actual MCUs.

(2) Port output timing

When using the M34514T-MCU, output timings are different from those of the actual MCUs for the following ports that are configured with port emulation circuits:

- Ports P0₀ to P0₃
- Ports P1₀ to P1₃
- Ports D₀ to D₅

With the actual MCUs, changes occur at the beginning of the T3 state of an output instruction. With the M34514T-MCU, changes occur at the beginning of the T2 state of the next output instruction. Figure 5.2 shows the port output timings of the actual MCUs and M34514T-MCU. For the other ports, the output timings are the same as with the actual MCUs.

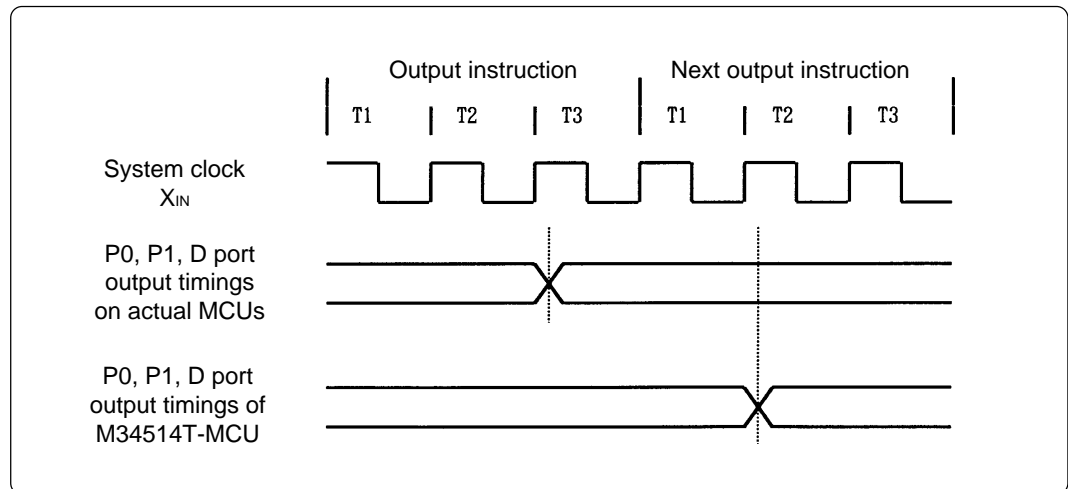

Figure 5.2 P0, P1 and D port output timings

5.7 Port I/O Characteristics

With the M34514T-MCU, port I/O characteristics are different from actual MCUs because there is an emulation circuit in ports P0, P1, P2 and D0 to D5. Table 5.2 lists port I/O characteristics of the M34514T-MCU.

Table 5.2 Emulation port I/O characteristics

| Port | | Device | Item | Voltage | Min. | Max. | Remarks | | |
|----------|--------------|----------|-----------------|--------------------------|--------------|-------------------------|---|--------------|---|
| P0, P1 | Input | 74HC4050 | V_{IH} | $V_{CC} = 2.0\text{ V}$ | 1.5 V | - | | | |
| | | | | $V_{CC} = 4.5\text{ V}$ | 3.15 V | - | | | |
| | | | V_{IL} | $V_{CC} = 2.0\text{ V}$ | - | 0.5 V | | | |
| | | | | $V_{CC} = 4.5\text{ V}$ | - | 1.35 V | | | |
| | Output | 74LS06 | I_{OH} | $V_{CC} = 4.75\text{ V}$ | - | 250 μA | $V_{OH} = \text{MAX}$ | | |
| | | | I_{OL} | | - | 40 mA | | | |
| V_{OL} | | | - | | 0.4 V | $I_{OL} = 16\text{ mA}$ | | | |
| | | | | - | 0.7 V | $I_{OL} = \text{MAX}$ | | | |
| P2 | Input/output | 74HC4066 | R_{ON} | $V_{CC} = 2.0\text{ V}$ | 160 Ω | - | $V_{IO} = V_{CC}$ to GND $I_{IO} \leq 1\text{ mA}$ | | |
| | | | | $V_{CC} = 4.5\text{ V}$ | 70 Ω | 130 Ω | | | |
| | | | | | | $V_{CC} = 4.5\text{ V}$ | 96 Ω | 200 Ω | $V_{IO} = V_{CC}$ or GND $I_{IO} \leq 1\text{ mA}$ |
| | | | ΔR_{ON} | $V_{CC} = 4.5\text{ V}$ | 10 Ω | - | $V_{IO} = V_{CC}$ to GND $I_{IO} \leq 1\text{ mA}$ | | |
| D5 to D0 | Input | 74HC4050 | V_{IH} | $V_{CC} = 2.0\text{ V}$ | 1.5 V | - | | | |
| | | | | $V_{CC} = 4.5\text{ V}$ | 3.15 V | - | | | |
| | | | V_{IL} | $V_{CC} = 2.0\text{ V}$ | - | 0.5 V | | | |
| | | | | $V_{CC} = 4.5\text{ V}$ | - | 1.35 V | | | |
| | Output | 74LS06 | I_{OH} | $V_{CC} = 4.75\text{ V}$ | - | 250 μA | $V_{OH} = \text{MAX}$ | | |
| | | | I_{OL} | | - | 40 mA | | | |
| V_{OL} | | | - | | 0.4 V | $I_{OL} = 16\text{ mA}$ | | | |
| | | | | - | 0.7 V | $I_{OL} = \text{MAX}$ | | | |

5.8 Power-down Mode

In the power-down mode, the M34514T-MCU operates differently from the actual chip of each MCU.

(1) Power-down operation of M34514T-MCU

Although the actual chip of each MCU is placed in the power-down mode by executing a combination of EPOF and POF instructions, the M34514T-MCU is placed in the power-down mode by only the POF instruction.

In the M34514T-MCU, the EPOF instruction does not have any effect.

Program example 5.1

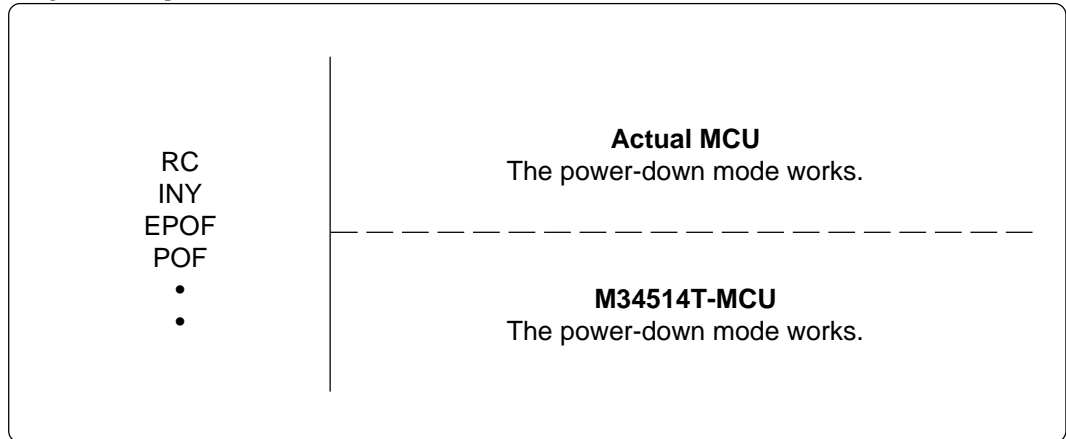

Program example 5.2

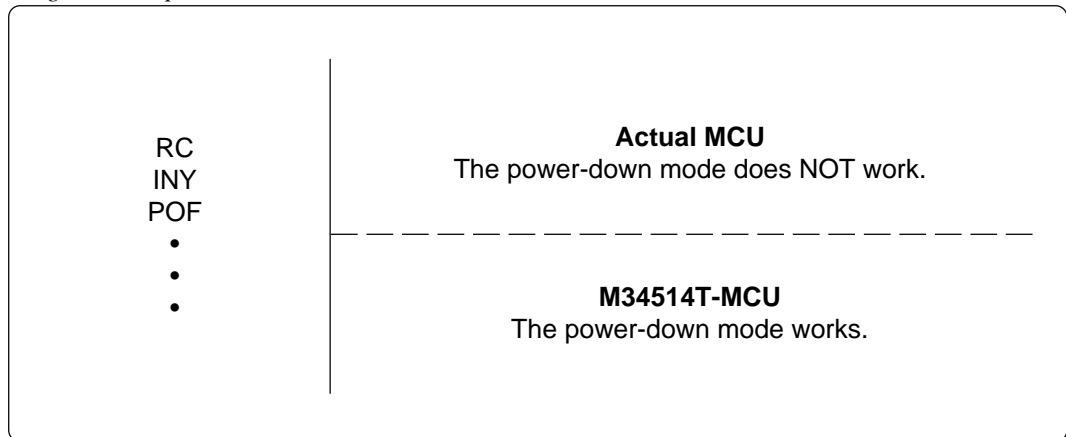

5.9 Program Execution (G, GB)

The PC4504 and M34514T-MCU's hardware are subject to the following restrictions with respect to the operation of the program execution commands (G and GB).

(1) Continuous description of instructions

Hardware breakpoints set in a continuous description of instructions following one after another do not cause a break to occur in the continuous description of instructions. A break occurs only after fetching the address where the continuous description of instructions is discontinued. (See Program example 5.3)

However, a break does occur even in a continuous description of instructions when an external trigger break or forced break is encountered. For execution to be resumed in this case, you need to make sure that the execution start address is next to the continuous description of instructions. (See Program example 5.4)

Program example 5.3

| | | | |
|----------|-----|---|--|
| | LA | 0 | |
| POINT: | LA | 1 | ; Continuous description of instructions |
| | LA | 2 | |
| POINT+2: | XAM | 3 | |

If a break is set at POINT, execution is halted immediately before the XAM instruction at address POINT+2.

Program example 5.4

| | | | |
|----------|-----|---|--|
| | LA | 0 | |
| POINT: | LA | 1 | ; Continuous description of instructions |
| POINT+1: | LA | 2 | |
| POINT+2: | XAM | 3 | |

If a forced or external trigger break is applied at POINT, execution is halted at POINT +1. When resuming program execution after the break, make sure that the start address is at POINT+2, an address immediately after the continuous description of instructions is discontinued.

(2) Skip instructions (e.g. SNZP, INY, DEY, SZB, SEAM, SZC and RTS)

When a skip instruction skips the next instruction, a breakpoint set in the skipped instruction does not cause execution to halt. (See Program examples 5.5 and 5.6)

Program example 5.5

| | | | | | | |
|---------|------|---|--|---------|------|---|
| | RC | | | SC | | |
| | SZC | | | SZC | | |
| POINT: | TABP | | | POINT: | TABP | |
| POINTA: | TAM | 0 | | POINTA: | TAM | 0 |
| | | • | | | | • |
| | | • | | | | • |

A breakpoint set at address POINT causes execution to halt immediately before address POINTA in only the case of the instruction shown on the right side.

Program example 5.6

| | | | | |
|--------|------|---|--|---------------------|
| | RC | | | ; Skip instructions |
| | INY | | | |
| POINT: | TABP | | | |
| | LA | 0 | | |
| | | • | | |
| | | • | | |

If a break with pass count is set at address POINT, the count is taken and execution is halted only when the instruction at address POINT is executed.

5.10 External Trigger Signal

(1) External trigger signal input timing

The latch timing of the external trigger signal is shown in Figure 5.3.

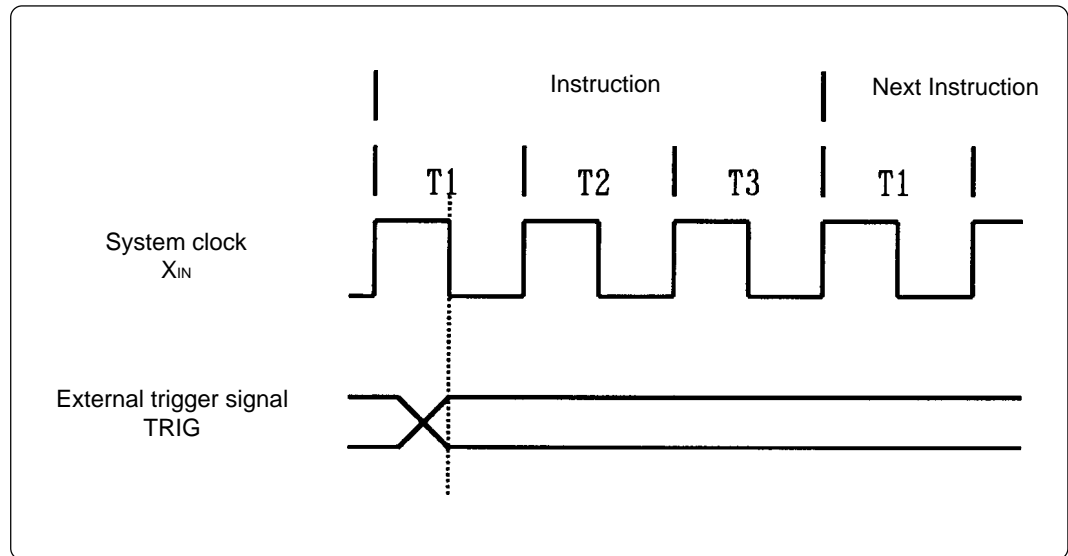

Figure 5.3 Latch timing of external trigger signal

(2) External trigger signal input characteristics

Trigger breaks work according to the condition (leading edge/trailing edge) of signals input from the external trace cable. The external trigger signals of the trace points and the external trigger signals of the break points use the same signals. The input characteristics of the external trigger signals are shown in Table 5.3 below. See the table before using external trigger signals.

Table 5.3 External trigger signal input characteristics

| Item | Symbol | Voltage | Maximum | Minimum |
|-----------------------|-----------------|-------------------------|---------|---------|
| H-level input voltage | V _{IH} | V _{CC} = 2.0 V | - | 1.5 V |
| | | V _{CC} = 4.5 V | - | 3.15 V |
| L-level input voltage | V _{IL} | V _{CC} = 2.0 V | 0.5 V | - |
| | | V _{CC} = 4.5 V | 1.35 V | - |

6. Connection Circuit Diagram

Figure 6.1 shows the connection circuit diagram of M34514T-MCU. This circuit diagram depicts the M34514T-MCU connection centering on circuits connected to the target system. Emulator control blocks and other similar circuits that are not connected to the target system are omitted in this diagram.

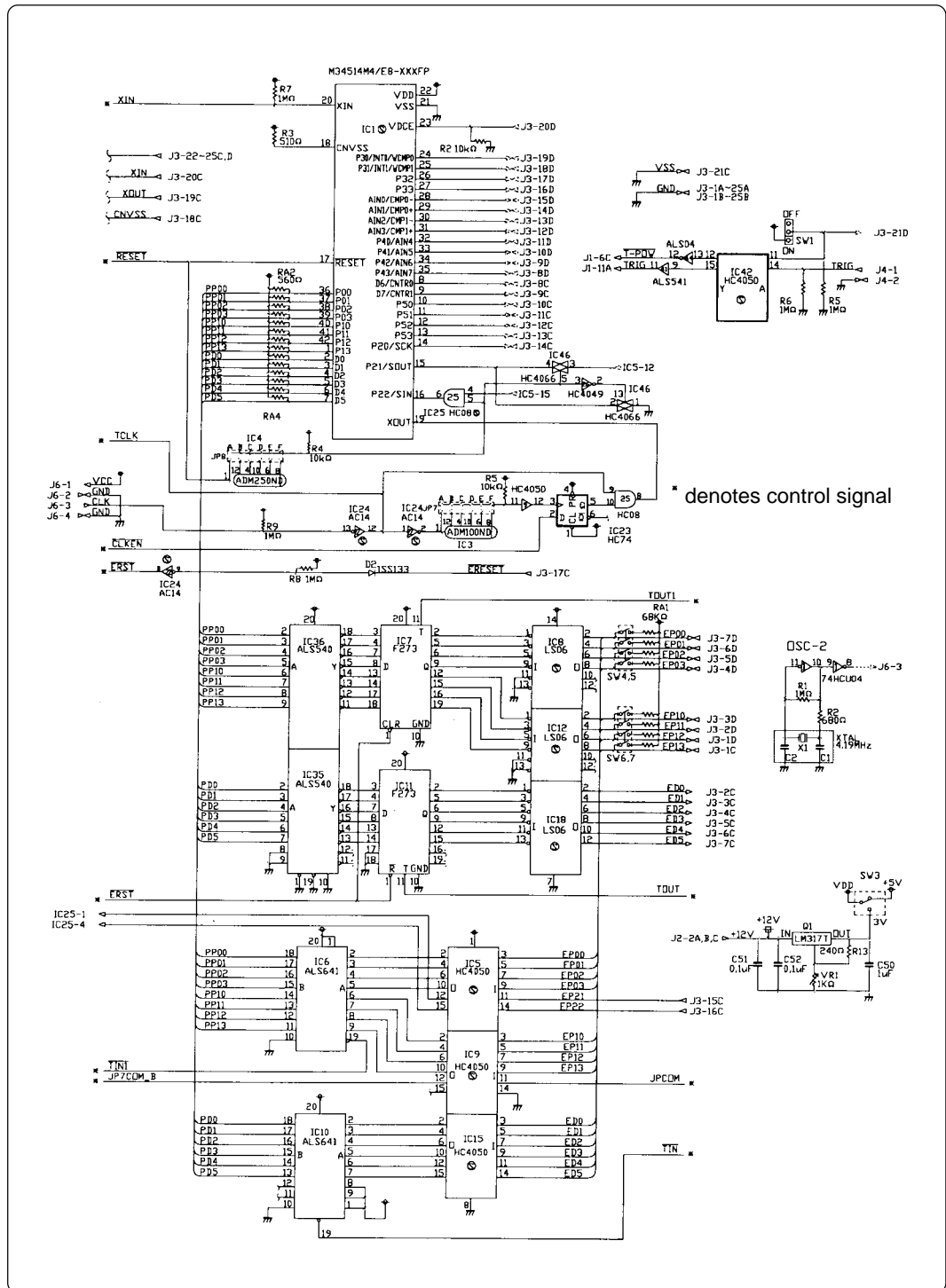

Figure 6.1 Connection circuit diagram

MEMO

7. Pitch Converter Board External Dimensions

7.1 M34513T-PTCA

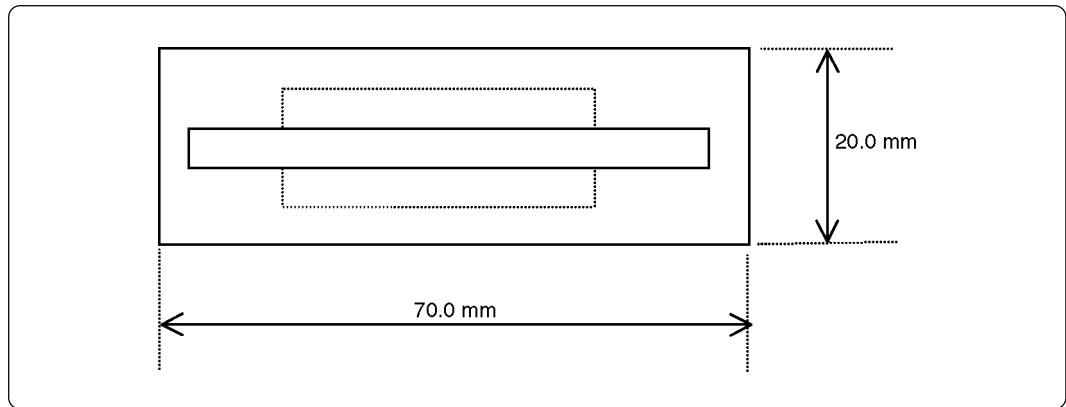

Figure 7.1 M34513T-PTCA external dimensions

7.2 M34513T-PTCB

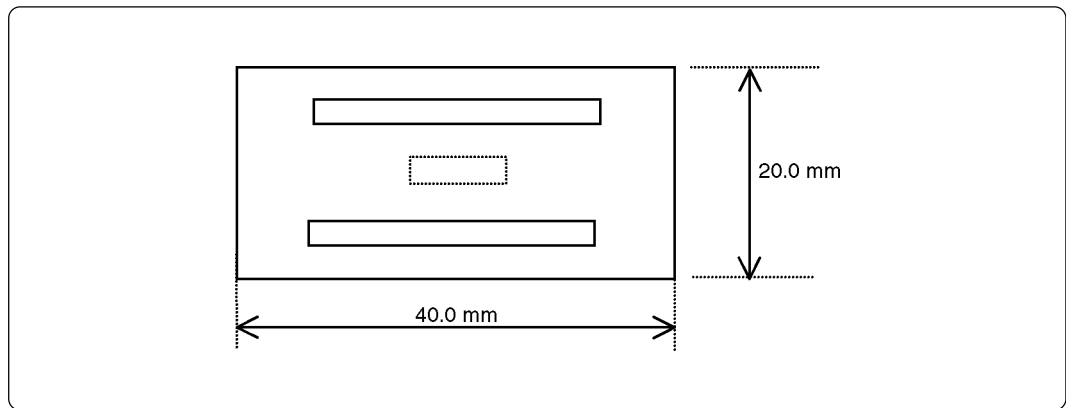

Figure 7.2 M34513T-PTCB external dimensions

7.3 M34513T-PTCC

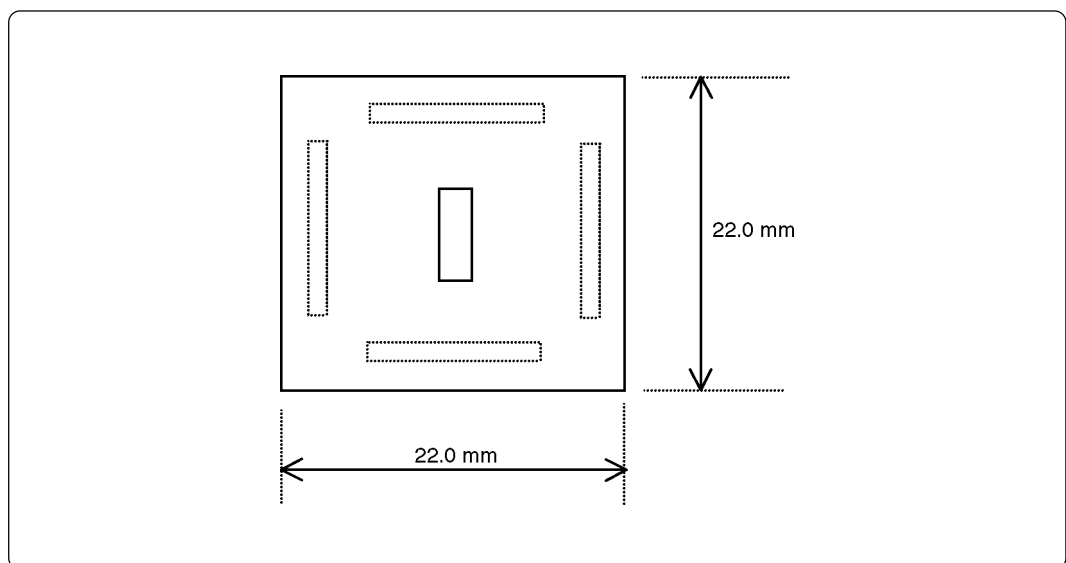

Figure 7.3 M34513T-PTCC external dimensions

Appendix A. How to Request for Repair

If your product is found faulty, follow the procedure below to send your product for repair.

Customer



Fill in the Repair Request Sheet included with this product, then send it along with this product for repair to your local distributor. Make sure that information in the Repair Request Sheet is written in as much detail as possible to facilitate repair.

Distributor



After checking the contents of fault, the distributor should please send the faulty product along with the Repair Request Sheet to Renesas Solutions Corp.

Renesas Solutions

When the faulty product is repaired, it will be returned to the customer at the earliest convenience.

CAUTION

Note on Transporting the Product:



- When sending your product for repair, use the packing box and cushion material supplied with this product when delivered to you and specify handling caution for it to be handled as precision equipment. If packing of your product is not complete, it may be damaged during transportation. When you pack your product in a bag, make sure to use conductive polyvinyl supplied with this product (usually a blue bag). When you use other bags, they may cause a trouble on your product because of static electricity.

M34514T-MCU User's Manual

Rev.1.00
September 1, 2003
REJ10J0274-0100Z

**COPYRIGHT ©2003 RENESAS TECHNOLOGY CORPORATION
AND RENESAS SOLUTIONS CORPORATION ALL RIGHTS RESERVED**



RenesasTechnology Corp.

2-6-2, Ote-machi, Chiyoda-ku, Tokyo, 100-0004, Japan

Free Manuals Download Website

<http://myh66.com>

<http://usermanuals.us>

<http://www.somanuals.com>

<http://www.4manuals.cc>

<http://www.manual-lib.com>

<http://www.404manual.com>

<http://www.luxmanual.com>

<http://aubethermostatmanual.com>

Golf course search by state

<http://golfingnear.com>

Email search by domain

<http://emailbydomain.com>

Auto manuals search

<http://auto.somanuals.com>

TV manuals search

<http://tv.somanuals.com>