



M37906T-PRB

Pod Probe for 7906 Group MCUs

User's Manual

- AXS69204201 is a product of Matsushita Electric Works, Ltd.

Keep safety first in your circuit designs!

- Renesas Technology Corporation and Renesas Solutions Corporation put the maximum effort into making semiconductor products better and more reliable, but there is always the possibility that trouble may occur with them. Trouble with semiconductors may lead to personal injury, fire or property damage. Remember to give due consideration to safety when making your circuit designs, with appropriate measures such as (i) placement of substitutive, auxiliary circuits, (ii) use of nonflammable material or (iii) prevention against any malfunction or mishap.

Notes regarding these materials

- These materials are intended as a reference to assist our customers in the selection of the Renesas Technology product best suited to the customer's application; they do not convey any license under any intellectual property rights, or any other rights, belonging to Renesas Technology Corporation, Renesas Solutions Corporation or a third party.
- Renesas Technology Corporation and Renesas Solutions Corporation assume no responsibility for any damage, or infringement of any third-party's rights, originating in the use of any product data, diagrams, charts, programs, algorithms, or circuit application examples contained in these materials.
- All information contained in these materials, including product data, diagrams, charts, programs and algorithms represents information on products at the time of publication of these materials, and are subject to change by Renesas Technology Corporation and Renesas Solutions Corporation without notice due to product improvements or other reasons. It is therefore recommended that customers contact Renesas Technology Corporation, Renesas Solutions Corporation or an authorized Renesas Technology product distributor for the latest product information before purchasing a product listed herein. The information described here may contain technical inaccuracies or typographical errors. Renesas Technology Corporation and Renesas Solutions Corporation assume no responsibility for any damage, liability, or other loss rising from these inaccuracies or errors. Please also pay attention to information published by Renesas Technology Corporation and Renesas Solutions Corporation by various means, including the Renesas home page (<http://www.renesas.com>).
- When using any or all of the information contained in these materials, including product data, diagrams, charts, programs, and algorithms, please be sure to evaluate all information as a total system before making a final decision on the applicability of the information and products. Renesas Technology Corporation and Renesas Solutions Corporation assume no responsibility for any damage, liability or other loss resulting from the information contained herein.
- Renesas Technology semiconductors are not designed or manufactured for use in a device or system that is used under circumstances in which human life is potentially at stake. Please contact Renesas Technology Corporation, Renesas Solutions Corporation or an authorized Renesas Technology product distributor when considering the use of a product contained herein for any specific purposes, such as apparatus or systems for transportation, vehicular, medical, aerospace, nuclear, or undersea repeater use.
- The prior written approval of Renesas Technology Corporation and Renesas Solutions Corporation is necessary to reprint or reproduce in whole or in part these materials.
- If these products or technologies are subject to the Japanese export control restrictions, they must be exported under a license from the Japanese government and cannot be imported into a country other than the approved destination. Any diversion or reexport contrary to the export control laws and regulations of Japan and/or the country of destination is prohibited.
- Please contact Renesas Technology Corporation or Renesas Solutions Corporation for further details on these materials or the products contained therein.

Precautions to be taken when using this product

- This product is a development supporting unit for use in your program development and evaluation stages. In mass-producing your program you have finished developing, be sure to make a judgment on your own risk that it can be put to practical use by performing integration test, evaluation, or some experiment else.
- In no event shall Renesas Solutions Corporation be liable for any consequence arising from the use of this product.
- Renesas Solutions Corporation strives to renovate or provide a workaround for product malfunction at some charge or without charge. However, this does not necessarily mean that Renesas Solutions Corporation guarantees the renovation or the provision under any circumstances.
- This product has been developed by assuming its use for program development and evaluation in laboratories. Therefore, it does not fall under the application of Electrical Appliance and Material Safety Law and protection against electromagnetic interference when used in Japan.

For inquiries about the contents of this document or product, fill in the text file the installer of the emulator debugger generates in the following directory and email to your local distributor.

\\SUPPORT\Product-name\SUPPORT.TXT

Renesas Tools Homepage <http://www.renesas.com/en/tools>

Preface

The M37906T-PRB is a pod probe for the 7906 Group of Renesas 16-bit microcomputers. The M37906T-PRB is used by connecting to the PC4701 emulator main unit and the M37900T2-RPD-E emulation pod main unit (option).

This manual mainly explains specifications and how to set up the M37906T-PRB. For detail information about the emulator main unit, emulation pod main unit, and emulator debugger, refer to each user's manual.

Emulator main unit	: PC4701 User's Manual
Emulation pod main unit	: M37900T2-RPD-E User's Manual
Emulator debugger	: M3T-PD79 User's Manual

To check the components of this product, refer to "2.2 Package Components" (page 17) in this manual. If there is any question or doubt about this product, contact your local distributor.

To use the product properly

Precautions for Safety:



- Both in this User's Manual and on the product itself, several icons are used to insure proper handling of this product and also to prevent injuries to you or other persons, or damage to your properties.
- The icons' graphic images and meanings are given in "Chapter 1 Precautions for Safety". Be sure to read this chapter before using the product.

Contents

Chapter 1. Precautions for Safety	7
1.1 Safety Symbols and Meanings	8
Warning for Installation	9
Warning for Use Environment	9
Caution to Be Taken for Modifying This Product	9
Cautions to Be Taken for This Product	9
Notes on Target System	10
Note on Reset Input from the Target System	10
Notes on Stack Area	10
Note on MCU Files	10
Notes on EMEM Dialog	11
Note on Boot Mode	11
Note on Breaks Used with Internal Resources	11
Note on Debug Monitor Area	11
Note on Interface with the Target System	12
Notes on Service-Life of the MCU's Internal Flash ROM	12
Note on Debug Commands during STP/WIT Instruction	12
Notes on Disabling Watchdog Function	12
Note on Real-Time RAM Monitor	12
Note on Coverage Measurement	12
Note on Differences between Actual MCU and Emulator	13
Chapter 2. Preparation	15
2.1 Terminology	16
2.2 Package Components	17
2.3 Other Tool Products Required for Development	17
2.4 System Configuration	18
Chapter 3. Setting Up	19
3.1 Switch Settings	20
3.2 A-D Conversion Bypass Capacitor	21
3.3 Connecting the Emulation Pod Main Unit	22
3.4 Connecting the Target System	24

Chapter 4. Specifications	27
4.1 Specifications	28
4.2 Electrical Characteristics	28
4.3 Connection Diagram	29
4.4 External Dimensions of Pod Probe	30
Chapter 5. Troubleshooting	31
5.1 When the Emulator Debugger Does Not Operate	32
(1) Errors Occur When Operating the Emulator Debugger (When the target system is connected).....	32
(2) Errors Occur When Operating the Emulator Debugger (When the target system is not connected)	33
5.2 Operation Differs from That of Actual MCUs	33
(1) Initializing the Internal Resources of MCU at Power-on.....	33
(2) Oscillator Circuits	33
(3) Flash ROM 2KB Expansion Area	33
(4) When the A-D Conversion Values are Different from Expected Values	33
(5) When the D-A Conversion Values are Different from Expected Values	33
Chapter 6. Maintenance and Warranty	35
6.1 Maintenance	36
6.2 Warranty	36
6.3 Repair Provisions	36
6.4 How to Request for Repair	37

MEMO

Chapter 1. Precautions for Safety

This chapter describes precautions for using this product safely and properly. For precautions for the emulator main unit, the emulation pod main unit and the emulator debugger, refer to each user's manual included with your product.



1.1 Safety Symbols and Meanings	8
WARNING Warning for Installation	9
Warning for Use Environment	9
CAUTION Caution to Be Taken for Modifying This Product	9
Cautions to Be Taken for This Product	9
IMPORTANT Notes on Target System	10
Note on Reset Input from the Target System	10
Notes on Stack Area	10
Note on MCU Files	10
Notes on EMEM Dialog	11
Note on Boot Mode	11
Note on Breaks Used with Internal Resources	11
Note on Debug Monitor Area	11
Note on Interface with the Target System	12
Notes on Service-Life of the MCU's Internal Flash ROM	12
Note on Debug Commands during STP/WIT Instruction	12
Notes on Disabling Watchdog Function	12
Note on Real-Time RAM Monitor	12
Note on Coverage Measurement	12
Note on Differences between Actual MCU and Emulator	13

Chapter 1. Precautions for Safety

In both the user's manual and on the product itself, several icons are used to insure proper handling of this product and also to prevent injuries to you or other persons, or damage to your properties.

This chapter describes the precautions which should be taken in order to use this product safely and properly. Be sure to read this chapter before using this product.

1.1 Safety Symbols and Meanings

	WARNING	If the requirements shown in the "WARNING" sentences are ignored, the equipment may cause serious personal injury or death.
	CAUTION	If the requirements shown in the "CAUTION" sentences are ignored, the equipment may malfunction.
	IMPORTANT	It means important information on using this product.

In addition to the three above, the following are also used as appropriate.

△ means WARNING or CAUTION.
Example:  **CAUTION AGAINST AN ELECTRIC SHOCK**

⊘ means PROHIBITION.
Example:  **DISASSEMBLY PROHIBITED**

● means A FORCIBLE ACTION.
Example:  **UNPLUG THE POWER CABLE FROM THE RECEPTACLE.**

The following pages describe the symbols "WARNING", "CAUTION", and "IMPORTANT".

WARNING

Warning for Installation:



- Do not set this product in water or areas of high humidity. Spilling water or some other liquid into the main unit can cause an unreparable damage.

Warning for Use Environment:



- This equipment is to be used in an environment with a maximum ambient temperature of 35°C. Care should be taken that this temperature is not exceeded.

CAUTION

Caution to Be Taken for Modifying This Product:



- Do not disassemble or modify this product. Disassembling or modifying this product can cause damage. Disassembling and modifying the product will void your warranty.

Cautions to Be Taken for This Product:



- Use caution when handling the main unit. Be careful not to apply a mechanical shock.
- Do not touch the connector pins of the emulator main unit and the target MCU connector pins directly. Static electricity may damage the internal circuits.
- Do not pull the pod probe by the flexible cable (FLX120-RPD) for connecting to the emulator main unit or the flexible cable (FLX100) for connecting the target system. The cable may cause a break.
- Flexible cable FLX120-RPD and FLX100 are different from earlier models. The slits make them more flexible. However, excessive flexing or force may break conductors.
- Do not use inch-size screws for this equipment. The screws used in this equipment are all ISO (meter-size) type screws. When replacing screws, use same type screws as equipped before.

IMPORTANT

Notes on Target System:

- The Vcc pin of emulator is connected to the target system to observe the voltage of the target system. Therefore the emulator cannot supply the power to the target system. Design your system so that the target system is powered separately.
- The voltage of the target system should be within the range of the MCU specification and suit to the emulator MCUs as shown below:
 - For 5.0V version MCUs: +4.5 to +5.5V
- Do not change the voltage of the target system after turning on the power.
- Before powering on your emulator system, check that the host machine, the PC4701, M37900T2-RPD-E, the converter board and target system are all connected correctly. Next, turn on the power to each equipment following the procedure below.
 - (1) Turn ON/OFF the target system and the PC4701 as simultaneously as possible.
 - (2) When the PC4701 and emulator debugger M3T-PD79 start up, check the target status LEDs on the emulator main unit's front panel to see if this product is ready to operate.
 - Is the power supplied? Check that target status LED (POWER) is ON.
 - Is the clock supplied? Check that target status LED (CLOCK) is ON.

Note on Reset Input from the Target System:

- The reset input from the target system is accepted only while a user program is being executed (only while the RUN status LED on the PC4701's front panel is lit).

Notes on Stack Area:

- With this product, a maximum 26 bytes of the user stack is consumed as work area.
- If the user stack does not have enough area, do not use areas which cannot be used as stack (SFR area, RAM area which stores data, or ROM area) as work area. Using areas like this is a cause of user program crashes and destabilized emulator control. Therefore, ensure the +26 byte maximum capacity used by the user program as the user stack area.

Note on MCU Files:

- When starting up the emulator debugger M3T-PD79, select the MCU file corresponding to the MCU which is going to be debugged by Init dialog (MCU files are included with the emulator debugger M3T-PD79).

MCU	MCU file name
M37906F8	M37906F8.MCU
M37906M4	M37906M4.MCU

IMPORTANT

Notes on EMEM Dialog:

- When setting the EMEM dialog box of emulator debugger M3T-PD79, pay attention to the following:
 - (1) Processor Mode

Specify a processor mode for the target MCU to be debugged. With 7906 Group MCUs, only the single-chip mode is specifiable. If the MD0 pin setting is not "L" level, emulator debugger M3T-PD79 outputs an error message. In such a case, check the pin settings on the target system.
 - (2) Emem Address

Allocate the 1MB emulation memory that is included in the emulation pod. For the 7906 Group, it is not necessary to set this because this group operates only in the single-chip mode.
 - (3) ROM Address

Disable the allocated emulation memory against writes by the user program. For the 7906 Group, it is not necessary to set this because this group operates only in the single-chip mode.
 - (4) DMA Address

In this dialog box, set a transfer area when using the MCU's DMA function, and executing 1-bus transfer between emulation memory and the target system. For the 7906 Group, do not set such areas because this group does not have the DMA function.
 - (5) 8-bit bus mode Address

When accessing external data buses in 8-bit width using the chip select wait controller when BYTE pin = Low, set this address for the relevant area. For the 7906 Group, it is not necessary to set this because this group operates only in the single-chip mode.
 - (6) Map Address

Set external or internal for the allocated emulation memory area. For the 7906 Group, it is not necessary to set this because this group operates only in the single-chip mode.

Note on Boot Mode:

- It is not possible to debug the MCUs in the boot mode using this emulator system.
(The MD1 pin of the MCU is fixed to the "L" level.)

Note on Breaks Used with Internal Resources:

- H/W breaks cannot be used with internal resources (SFR, internal RAM and internal flash ROM) when using emulator PC4701L.

Note on Debug Monitor Area:

- The debug monitor area is fixed to the "FF" bank. It cannot be set to other banks.

IMPORTANT

Note on Interface with the Target System:

- The pin that connects to the target system is pulled-up by the emulation pod probe using local resistors. For the difference in electric characteristics between the actual MCU and the emulator, see "Chapter 4. Specifications" (page 27).

Pullup resistors of Init4* pin

To avoid high impedance, this pin is pulled-up with a 510kΩ resistor. These pullup resistors cannot be removed.

Notes on Service-Life of the MCU's Internal Flash ROM:

- With emulators of the 7900 Series, programs are downloaded to the MCU's flash ROM when debugging in the single-chip mode and memory expansion mode. Because the number of write/erase cycles of this ROM is limited, the ROM must be replaced when at the end of its service-life.
- If the following errors occur frequently during program download, replace the MCU board (M37906T-PRBM).

Flash memory erase error ERROR (11508)

Flash memory verify error ERROR (11509)

To purchase the MCU board (M37906T-PRBM) for replacement, contact your local distributor.

Note on Debug Commands during STP/WIT Instruction:

- When a debug command (e.g. referencing memory) is issued during execution of STP/WIT instruction, STP/WIT instruction is canceled. And when the debug program has completed, the following instructions are executed.

Note on Disabling Watchdog Function:

- When disabling the watchdog timer during programming, do not open the DUMP window, the memory window and the RAM monitor window in the area which contains the special function select register 2 (address 64h). When displaying address 64h, it is not possible to disable the timer.

Note on Real-Time RAM Monitor:

- Word access from an odd-numbered address cannot be correctly displayed. This restriction of the MCU - emulator interface cannot be avoided. Use the optional function of assembler AS79 to arrange word data to start from an even-numbered address.

Note on Coverage Measurement:

- The trace data output from the MCU is operational code address information only. Make note of the fact that, in coverage measurement, the calculation result is unpredictable because the operand address is not tagged.

IMPORTANT

Note on Differences between Actual MCU and Emulator:

- Operations of the emulator differs from those of mask MCUs as listed below.
 - (1) Initial values of internal resource data (such as a part of SFR, and RAM) at power-on
 - (2) Oscillator circuit

Make note of the fact that in the oscillator circuit where a resonator is connected between the X_{IN} and X_{OUT} pins, oscillation does not occur because a flexible cable, buffer IC and other devices are used between the emulator MCU and the target system.

MEMO

Chapter 2. Preparation

This chapter describes the package components, the system configuration and the preparation for using this product for the first time.

2.1 Terminology	16
2.2 Package Components	17
2.3 Other Tool Products Required for Development	17
2.4 System Configuration	18

Chapter 2. Preparation

2.1 Terminology

Some specific words used in this user's manual are defined as follows:

Emulator system

This means an emulator system built around the PC4701 emulator. The PC4701 emulator system is configured with an emulator main unit, emulation pod, pod probe, host machine and emulator debugger.

Emulator main unit (Hereafter PC4701)

This means a generic name for emulators for 8 and 16-bit MCUs. For details on specific models of PC4701, visit Renesas Tools Homepage at <http://www.renesas.com/en/tools>

Emulation pod

This means the common part which matches to the 7900 Series MCUs. The emulation pod is used by connecting the pod probe.

Pod probe

This means the pod probe for 7906 Group M37906T-PRB (this product).

Host machine

This means a personal computer used to control the emulator and emulation pod.

Emulator debugger

This means a software tool M3T-PD79 to control the emulator from the host machine through an interface.

Firmware

Program that analyzes contents of communication with the emulator debugger and controls the emulator hardware. This program is installed in the EEPROM. This program is downloadable from the emulator debugger to upgrade the firmware or to support other MCUs.

Emulator MCU

This means the special package MCU for the emulator mounted on the emulation pod.

Target system

This means a user's application system using the microcomputer to be debugged.

*

In this user's manual, this symbol is used to show active LOW. (e.g. RESET*: Reset signal)

2.2 Package Components

This product consists of the following items. When unpacking, check to see if your product package contains all of these items.

Package components

Item	Quantity
M37906T-PRB pod probe for 7906 Group MCUs	1
SSOP42B-450 converter board for 42-pin SSOP (42P2R-A)	1
M37906T-PRB User's Manual (this manual)	1
M37906T-PRB User's Manual (Japanese)	1
M37906T-PRB Repair Request Sheet (English/Japanese)	1
Technical Support Communication Sheet (English/Japanese)	1

Please keep the M37906T-PRB's packing box and cushion material in your place for reuse at a later time when sending your product for repair or other purposes. Always use these packing box and cushion material when transporting the M37906T-PRB.

If any of these items are missing or found faulty, please contact your local distributor. Also, if there is any question or doubt about the packaged product, contact your local distributor.

2.3 Other Tool Products Required for Development

To bring forward programs development on the 7906 Group MCUs, the products listed below are necessary in addition to the package components listed above. Get them separately.

Other tool products

Emulator main unit	PC4701
Emulation pod main unit	M37900T2-RPD-E
Emulator debugger	M3T-PD79 Ver.2.10 or greater is recommended
Converter board	Converter board FLX-42SPB Necessary for using SDIP (42P4B)

To purchase these products, contact your nearest distributor.

2.4 System Configuration

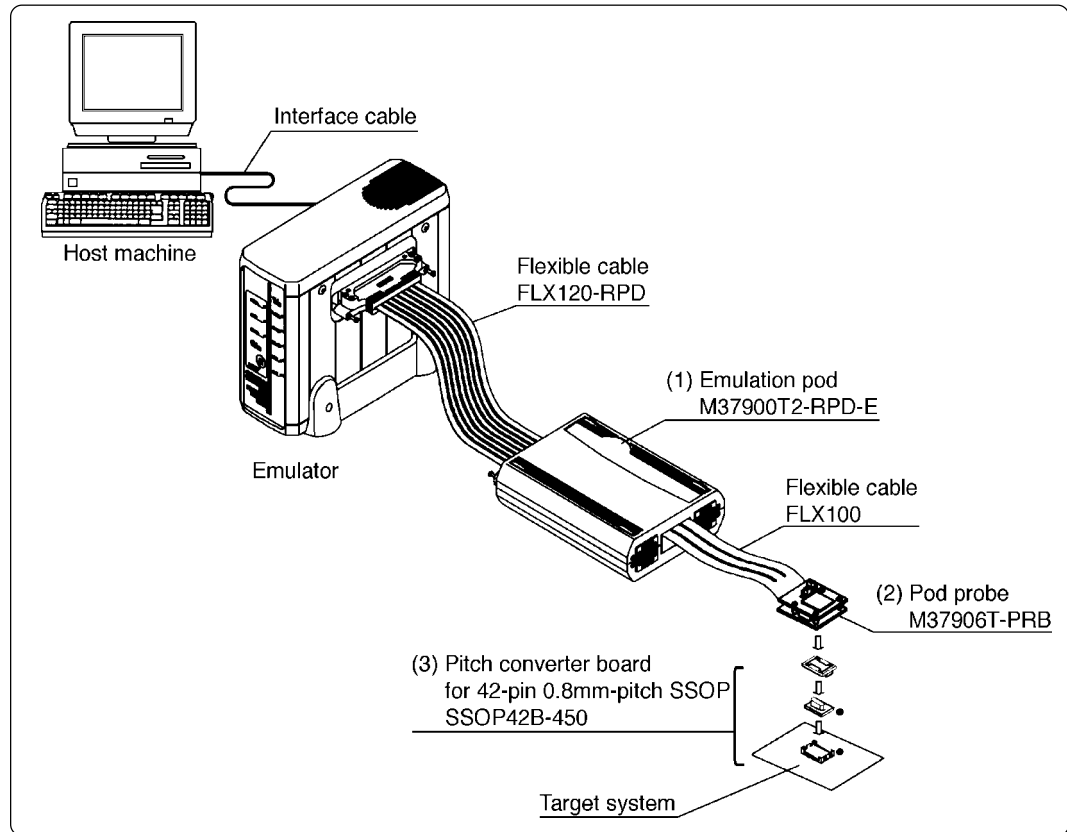

Figure 2.1 System configuration

Products (2) and (3) shown in Figure 2.1 are included with this product. Get (1) in Figure 2.1 separately.

(1) Emulation pod main unit (M37900T2-RPD-E)

This is an emulation pod common for 7900 Series MCUs. By replacing the pod probe on the tip of the emulation pod, it will support future 7900 Series MCUs (option).

(2) Pod probe (M37906T-PRB)

This pod probe is equipped with the emulator MCU, M37906FCCWP.

(3) Pitch converter board for 42-pin 0.8mm-pitch SSOP (SSOP42B-450)

Board for connecting the pod probe to the socket for 42-pin 0.8mm-pitch SSOP on the target system.

For details on the connection, refer to "3.4 Connecting the Target System" (page 24).

Chapter 3. Setting Up

This chapter describes switch settings required for using this product and how to connect this product to the PC4701 and the target system.

3.1 Switch Settings	20
3.2 A-D Conversion Bypass Capacitor	21
3.3 Connecting the Emulation Pod Main Unit	22
3.4 Connecting the Target System.....	24

Chapter 3. Setting Up

With this product, it is necessary to set the following according to your target system.

- Setting switches
- Mounting the A-D conversion bypass capacitor

3.1 Switch Settings

It is necessary to set the switches of the M37906T-PRB for debugging according to the target system.

Figure 3.1 shows the positions of the switches of the M37906T-PRB, and Table 3.1 shows the switch settings.

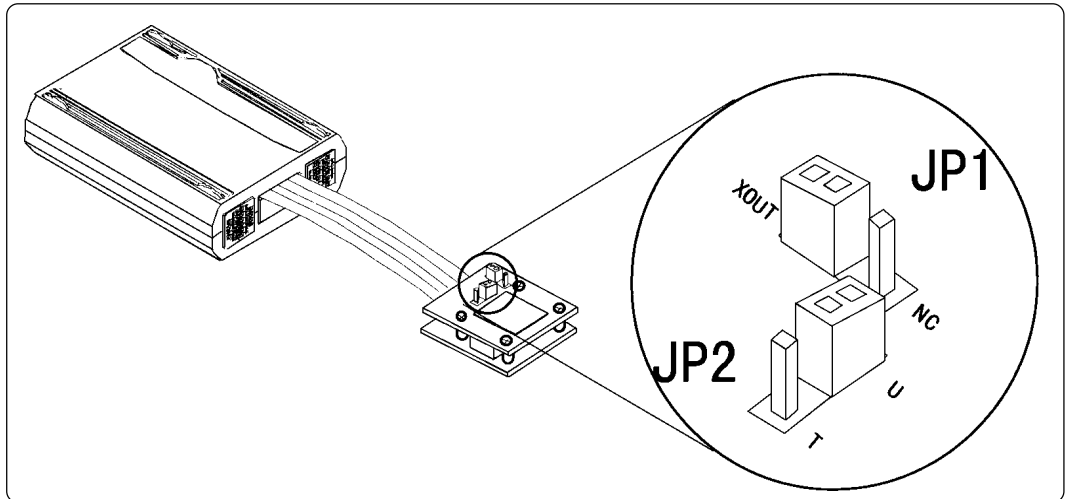

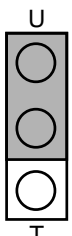
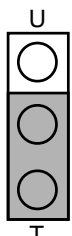

Figure 3.1 Positions of the switches and their factory-settings

Table 3.1 Switch settings of M37906T-PRB

Function	Switch No.	Switch setting	
X _{OUT} output selected	JP1	X _{OUT}  N.C. Does not output X _{OUT} (Factory-setting)	X _{OUT}  N.C. Outputs X _{OUT}
PLL filter circuit selected	JP2	 When using the PLL filter circuit on the target system or not using the PLL function (Factory-setting)	 When using the PLL filter circuit on the pod probe

CAUTION

Note on Switch Settings:

- Always shut OFF power before setting switches. The power ON state could destroy internal circuits.

3.2 A-D Conversion Bypass Capacitor

This product has foot patterns on the board for mounting a bypass capacitor for the A-D converter circuit. Mount a suitable bypass capacitor as occasion demands.

Figure 3.2 shows the position of the bypass capacitor.

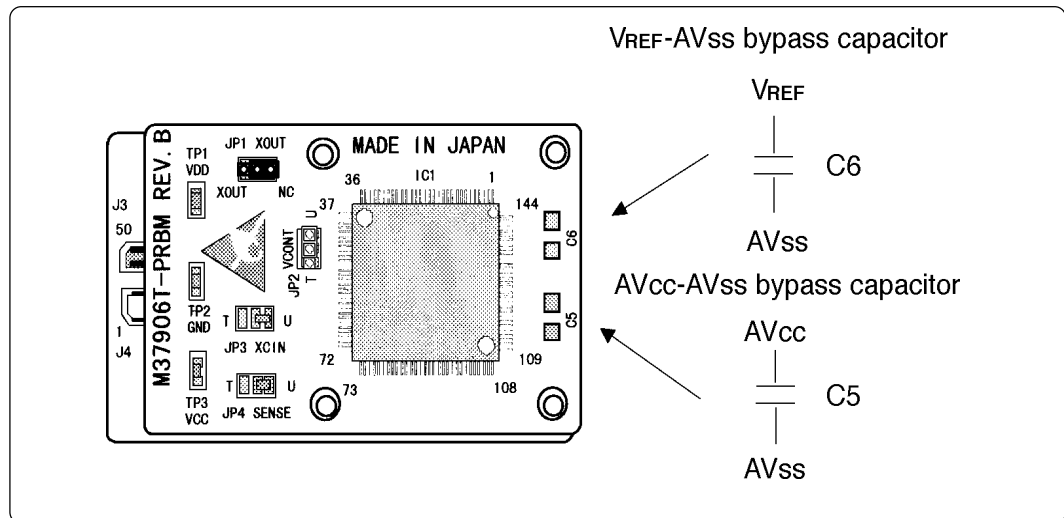

Figure 3.2 Foot patterns of A-D conversion bypass capacitor

IMPORTANT

Note on the Operation of A-D Converter:

- The characteristics of A-D converter differ from those of actual MCU because there are a converter board and other devices between the evaluation MCU and the target system. Make the final evaluation of the A-D converter with the actual MCU.

3.3 Connecting the Emulation Pod Main Unit

The emulation pod for 7906 Group MCUs consists of the following two products.

- (1) Emulation pod : M37900T2-RPD-E
- (2) Pod probe : M37906T-PRB

It is necessary to connect the M37906T-PRB to the M37900T2-RPD-E for the emulation of 7906 Group MCUs. Figure 3.3 shows how to connect them.

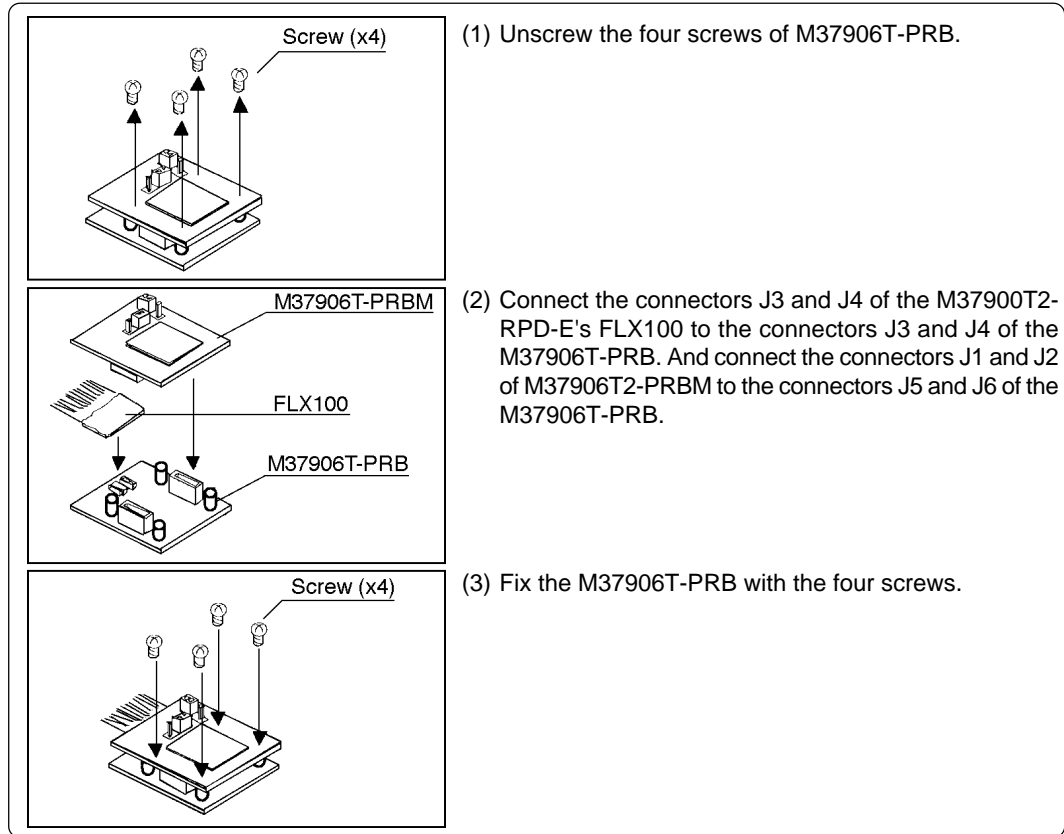

Figure 3.3 Connecting pod probe M37906T-PRB

With the 7900 Series emulator system, the internal flash ROM of the emulator MCU is used as an emulation memory.

As write/erase iterations to the internal ROM are limited, it is necessary to replace the MCU board (M37906T-PRBM) depending on its life span.

How to replace the MCU board is shown in Figure 3.4.

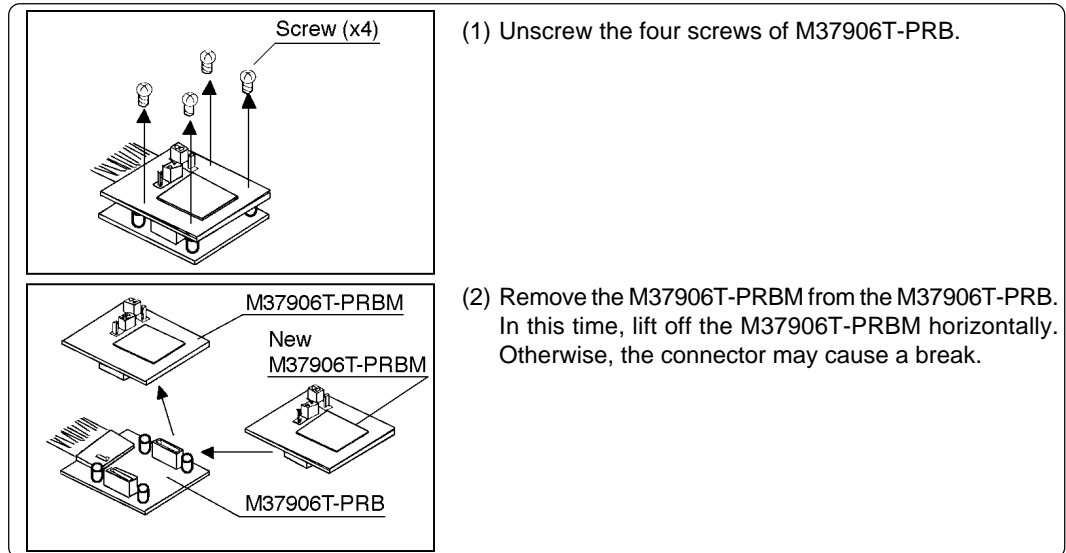

Figure 3.4 Removing MCU board M37906T-PRBM

CAUTION

When Connecting Pod Probe:

- Be sure to turn off the power before making connections. Otherwise, the internal circuits may be damaged.
- The small connectors (J3 and J4) of the M37906T-PRB are guaranteed for only 20 insertion/removal iterations.
- The small connectors (J1 and J2) of the M37906T-PRBM and those (J5 and J6) of the M37906T-PRB are guaranteed for only 50 insertion/removal iterations.

3.4 Connecting the Target System

There are three ways available to connect the emulation pod to target systems as shown in Figure 3.5.

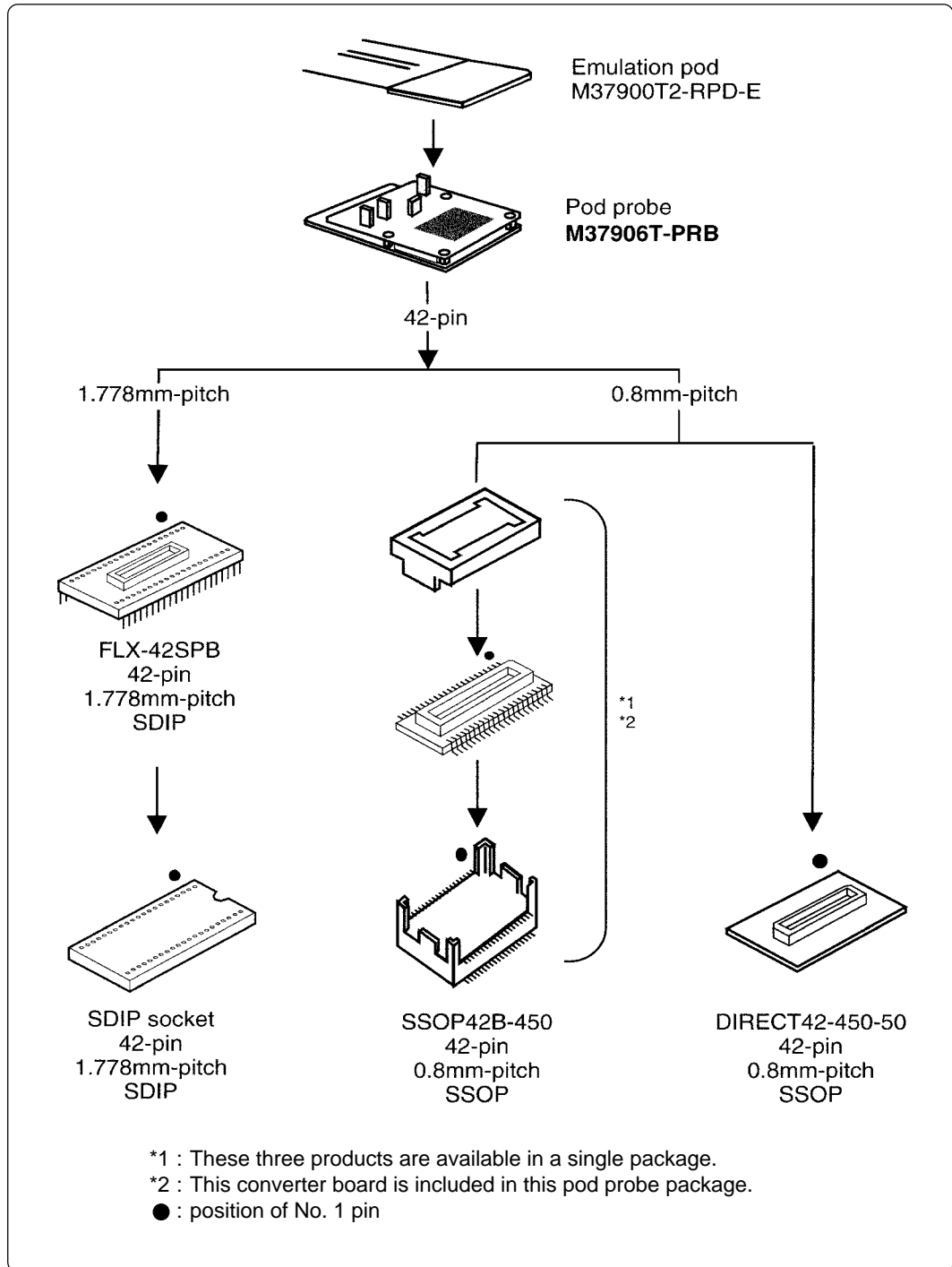

Figure 3.5 Connecting the target system

Figure 3.6 shows how to connect the pitch converter board SSOP42B-450 for 42-pin 0.8mm-pitch SSOP.

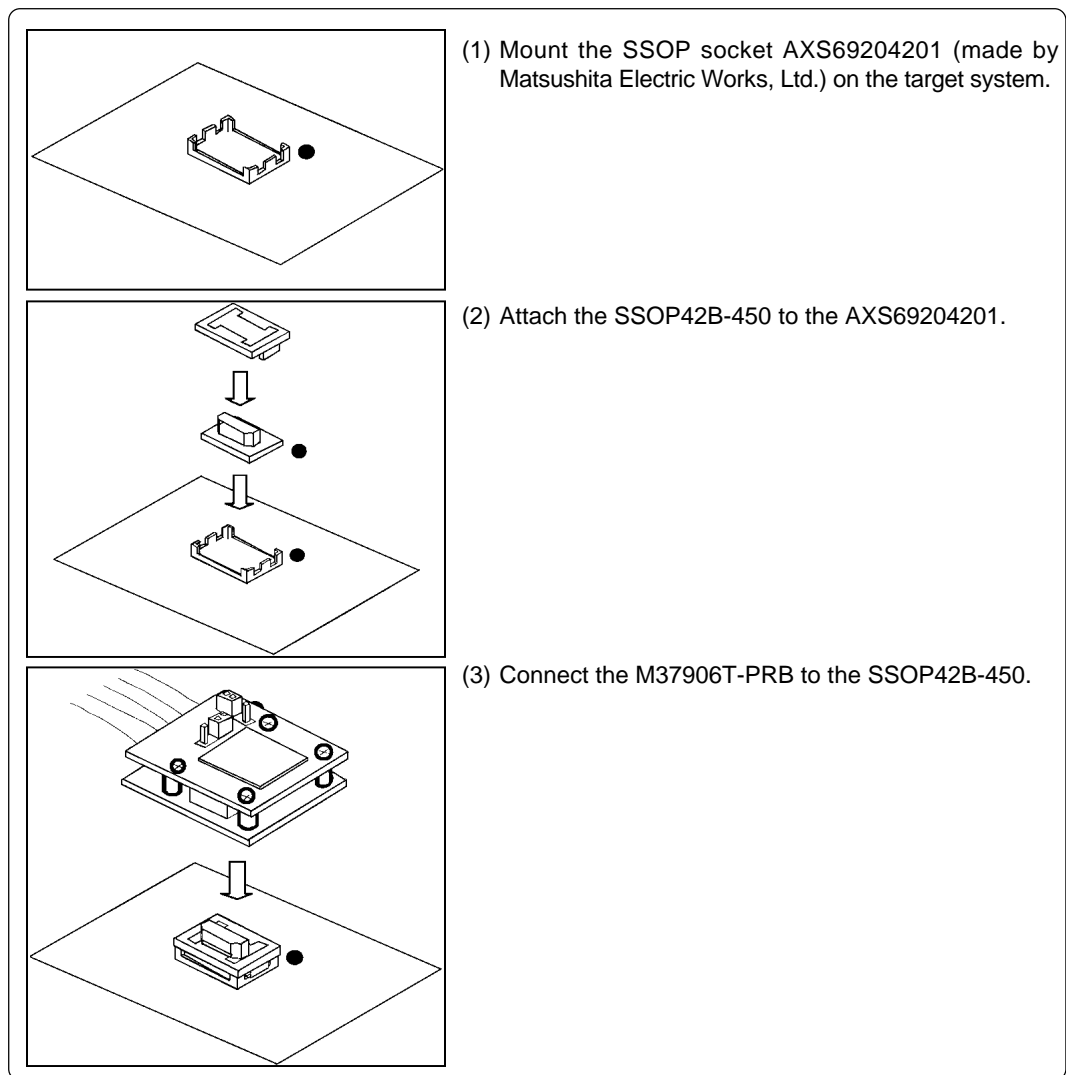

Figure 3.6 Connecting the pitch converter board SSOP42B-450 for 42-pin 0.8mm-pitch SSOP

CAUTION

Notes on Connecting the Target System:

- Always shut OFF power before connecting the target system.
- Take care not to attach the converter board in an inverted position. It may cause a fatal damage to the internal circuit.

MEMO

Chapter 4. Specifications

This chapter describes specifications of this product.

4.1 Specifications	28
4.2 Electrical Characteristics	28
4.3 Connection Diagram	29
4.4 External Dimensions of Pod Probe	30

Chapter 4. Specifications

4.1 Specifications

Table 4.1 lists the specifications of the M37906T-PRB.

Table 4.1 Specifications of M37906T-PRB

Emulators		PC4701
Emulation pod main unit		M37900T2-RPD-E
Applicable MCUs		7906 Group MCUs
Emulator MCU		M37906FCCWP (pre-mounted on the M37906T-PRBM)
Usable MCU mode		Single-chip mode
Running mode	Max. operating frequency	20MHz
	Clock supply	Internal oscillator board, switchable to an external oscillator
	Min. instruction execution time	Approx. 50ns (20MHz)
Operating temperature range		5 to 35°C (no dew)
Storage temperature range		-10 to 60°C (no dew)
Power supply to emulation pod		Supplied from the emulator main unit
Connection to the target system	42P2R-A	When connecting to the 0.8mm-pitch 42-pin SSOP foot pattern, possible to connect via the SSOP42B-450.
	42P4B	When connecting to the 1.778mm-pitch 42-pin SDIP foot pattern, possible to connect via the FLX-42SPB (option).

4.2 Electrical Characteristics

The pins of MCU excluding X_{IN} , MD0, MD1 and RESET* pins are directly connected to the target system via the converter board.

Table 4.2 lists the electrical characteristics of the device used for X_{IN} , MD0 and RESET* pins.

Table 4.2 Electrical characteristics of X_{IN} , MD0 and RESET*

Symbol	Parameter	Standard values			Unit
		V_{CC}	Min.	Max.	
V_{IH}	High level input voltage	3.0 to 5.0	$V_{CC} \times 0.7$	-	V
V_{IL}	Low level input voltage	3.0 to 5.0	-	$V_{CC} \times 0.3$	V
I_{IN}	Input current	0.0 to 5.0	-	± 0.1	μA

4.3 Connection Diagram

Figure 4.1 shows the connection diagram of the emulation pod for 7906 Group (M37900T2-RPD-E and M37906T-PRB). This connection diagram mainly shows the interface section, and the circuits which are not connected to the target system such as the emulator's control system are omitted.

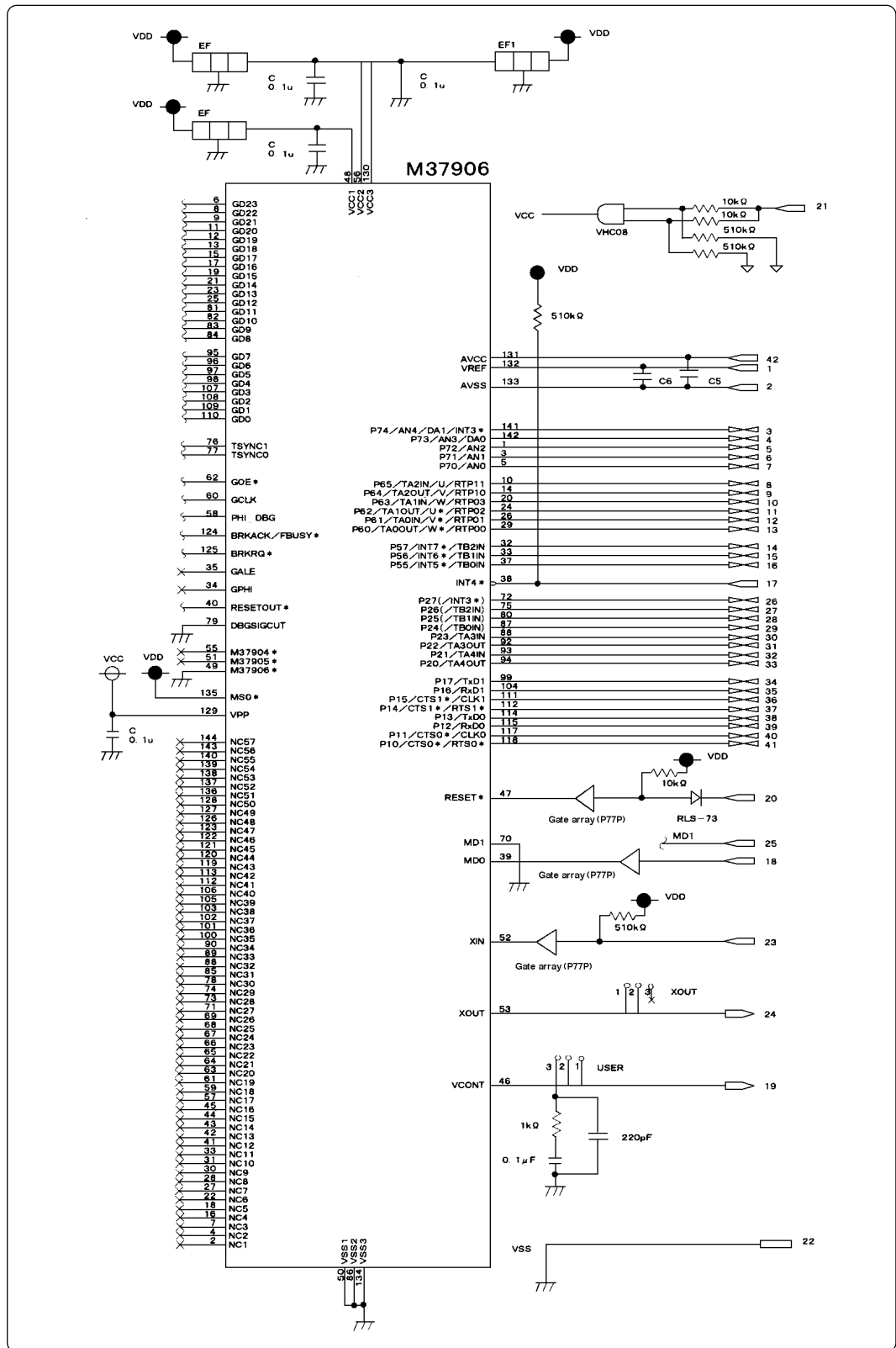

Figure 4.1 Connection diagram

4.4 External Dimensions of Pod Probe

Figure 4.2 shows the external dimensions of M37906T-PRB.

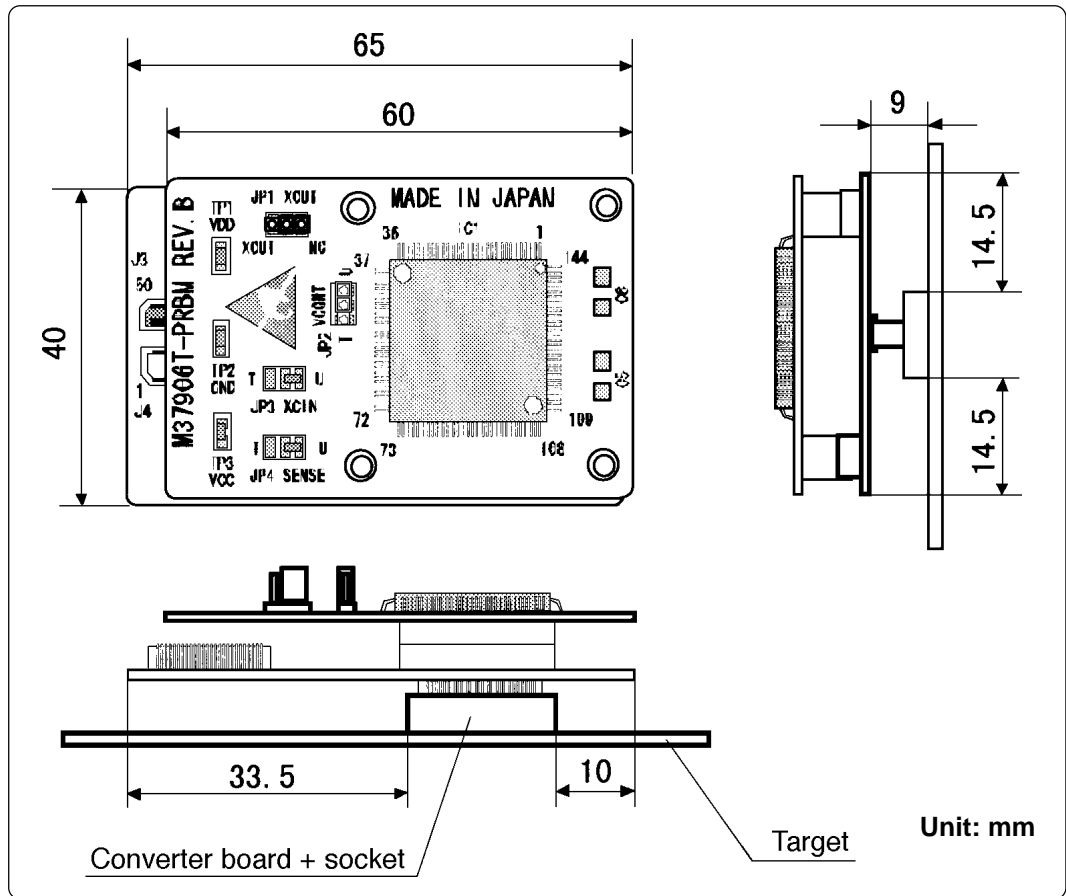

Figure 4.2 External dimensions of pod probe (M37906T-PRB)

Chapter 5. Troubleshooting

This chapter describes how to troubleshoot when this product does not work properly.

5.1	When the Emulator Debugger Does Not Operate	32
	(1) Errors Occur When Operating the Emulator Debugger (When the target system is connected)	32
	(2) Errors Occur When Operating the Emulator Debugger (When the target system is not connected)	33
5.2	Operation Differs from That of Actual MCUs	33
	(1) Initializing the Internal Resources of MCU at Power-on	33
	(2) Oscillator Circuits	33
	(3) Flash ROM 2KB Expansion Area	33
	(4) When the A-D Conversion Values are Different from Expected Values	33
	(5) When the D-A Conversion Values are Different from Expected Values	33

Chapter 5. Troubleshooting

When this product does not work properly, check the following.

5.1 When the Emulator Debugger Does Not Operate

(1) Errors Occur When Operating the Emulator Debugger (When the target system is connected)

Table 5.1 Checkpoints of errors when starting up the emulator debugger M3T-PD79 (target is connected)

Error	Checkpoint
Communication ERROR Data is not sent to the target	Check all emulator debugger settings, interface cable connections and switches on the rear of the PC4701 match. - See the user's manuals of the PC4701 and emulator debugger.
Target system is not constructed properly	(1) Download the proper firmware. - See the user's manuals of the emulator debugger. (2) Recheck the connection between the PC4701, the emulation pod and this product. - See "3.3 Connecting the Emulation Pod Main Unit" (page 22). - See user's manual of the M37900T2-RPD-E.
The version of M3T-PD79 and the firmware on the target system are not same	Download the proper firmware. - See the user's manual of the emulator debugger.
Target MCU is reset state	(1) Check the reset pin of the target system is pulled up. (2) Check the reset pin of the target system has changed from "L" to "H" level.
Target MCU cannot be reset Flash ROM erase error occurred	(1) If the reset circuit of the target system has a watchdog timer, disable the timer. (2) Check power is properly supplied to the target system and that the target system is properly grounded. (3) Check your emulator debugger M3T-PD79 is Ver.2.10 or greater. (4) The flash ROM of the MCU may be worn-out. Contact your local distributor.
Target clock is stopped	Check the oscillation circuit of the target system is oscillating properly.
Target MCU is not receiving power	Check power is properly supplied to the target system and that the target system is properly grounded.
Not connected to target Cannot connect to target	(1) Recheck the connection of the emulation pod and this product. - See "3.3 Connecting the Emulation Pod Main Unit" (page 22). (2) Recheck the connection of the SSOP42B-450 and the socket. - See "3.4 Connecting the Target System" (page 24).
Target MCU is uncontrollable Reset target system	Check the program is not accessing to the unused area.

**(2) Errors Occur When Operating the Emulator Debugger
(When the target system is not connected)**

Table 5.2 Checkpoints of errors when starting up the emulator debugger M3T-PD79 (target is not connected)

Error	Checkpoint
Communication ERROR Data is not sent to the target	Check all emulator debugger settings, interface cable connections and switches on the rear of the PC4701 match. - See the user's manuals of the PC4701 and emulator debugger.
Target system is not constructed properly	(1) Download the proper firmware. - See the user's manual of the emulator debugger. (2) Recheck the connection between the PC4701, the emulation pod and this product. - See "3.3 Connecting the Emulation Pod Main Unit" (page 22). - See user's manual of the M37900T2-RPD-E.
The version of M3T-PD79 and the firmware on the target are not same	Download the proper firmware. - See the user's manual of the emulator debugger.
Target MCU cannot be reset Flash ROM erase error occurred	(1) Check your emulator debugger M3T-PD79 is Ver.2.10 or greater. (2) The flash ROM of the MCU may be worn-out. Contact your local distributor.
Target MCU is uncontrollable Reset target system	(1) Check the program is not accessing to the unused area. (2) When using the PLL circuit, check the switch settings of the pod probe. - "3.1 Switch Settings" (page 20).

5.2 Operation Differs from That of Actual MCUs

(1) Initializing the Internal Resources of MCU at Power-on

With this product, the internal resources of the MCU are initialized when starting up the emulator. Therefore, the operation differs from that of actual MCUs.

(2) Oscillator Circuits

Make note of the fact that in the oscillator circuit where a resonator is connected between the X_{IN} and X_{OUT} pins, oscillation does not occur because a flexible cable, buffer IC and other devices are used between the emulator MCU and the target system.

(3) Flash ROM 2KB Expansion Area

In the DUMP window of emulator debugger M3T-PD79, the data of flash ROM 2KB expansion area is displayed regardless of the setting of SFR area.

(4) When the A-D Conversion Values are Different from Expected Values

The A-D converter characteristics differ from actual MCU characteristics because there are a converter board and other devices between the MCU and the target system. Make the final evaluation of the A-D converter with the actual MCU.

(5) When the D-A Conversion Values are Different from Expected Values

The D-A converter characteristics differ from actual MCU characteristics because there are a converter board and other devices between the MCU and the target system. Make the final evaluation of the D-A converter with the actual MCU.

MEMO

Chapter 6. Maintenance and Warranty

This chapter describes how to maintenance, repair provisions and how to request for repair.

6.1 Maintenance	36
6.2 Warranty	36
6.3 Repair Provisions.....	36
6.4 How to Request for Repair	37

Chapter 6. Maintenance and Guarantee

6.1 Maintenance

If dust or dirt collects on any equipment of your emulation system, wipe it off with a dry soft cloth. Do not use thinner or other solvents because these chemicals can cause the equipment's surface coating to separate.

6.2 Guarantee

If your product becomes faulty within one year after its purchase while being used under good conditions by observing "Precautions for Safety" described in Chapter 1 of this user's manual, we will repair or replace your faulty product free of charge. Note, however, that if your product's fault is raised by any one of the following causes, we will repair it or replace it with new one with extra-charge:

- Misuse, abuse, or use under extraordinary conditions
- Unauthorized repair, remodeling, maintenance, and so on
- Inadequate user's system or misuse of it
- Fires, earthquakes, and other unexpected disasters

In the above cases, contact your local distributor. If your product is being leased, consult the leasing company or the owner.

6.3 Repair Provisions

(1) Repair with extra-charge

The products elapsed more than one year after purchase can be repaired with extra-charge.

(2) Replacement with extra-charge

If your product's fault falls in any of the following categories, the fault will be corrected by replacing the entire product instead of repair, or you will be advised to purchase new one, depending on the severity of the fault.

- Faulty or broken mechanical portions
- Flaw, separation, or rust in coated or plated portions
- Flaw or cracks in plastic portions
- Faults or breakage caused by improper use or unauthorized repair or modification
- Heavily damaged electric circuits due to overvoltage, overcurrent or shorting of power supply
- Cracks in the printed circuit board or burnt-down patterns
- Wide range of faults that makes replacement less expensive than repair
- Unlocatable or unidentified faults

(3) Expiration of the repair period

When a period of one year elapses after the model was dropped from production, repairing products of the model may become impossible.

(4) Transportation fees at sending your product for repair

Please send your product to us for repair at your expense.

6.4 How to Request for Repair

If your product is found faulty, follow the procedure below to send your product for repair.

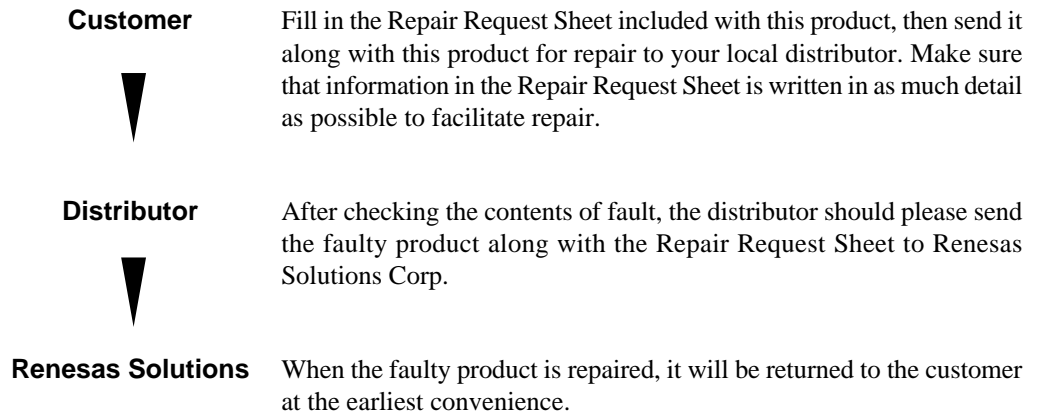

CAUTION

Note on Transporting the Product:



- When sending your product for repair, use the packing box and cushion material supplied with this product when delivered to you and specify handling caution for it to be handled as precision equipment. If packing of your product is not complete, it may be damaged during transportation. When you pack your product in a bag, make sure to use conductive polyvinyl supplied with this product (usually a blue bag). When you use other bags, they may cause a trouble on your product because of static electricity.

MEMO

M37906T-PRB User's Manual

Rev.1.00
September 1, 2003
REJ10J0288-0100Z

COPYRIGHT ©2003 RENESAS TECHNOLOGY CORPORATION
AND RENESAS SOLUTIONS CORPORATION ALL RIGHTS RESERVED



Renesas Technology Corp.

2-6-2, Ote-machi, Chiyoda-ku, Tokyo, 100-0004, Japan

Free Manuals Download Website

<http://myh66.com>

<http://usermanuals.us>

<http://www.somanuals.com>

<http://www.4manuals.cc>

<http://www.manual-lib.com>

<http://www.404manual.com>

<http://www.luxmanual.com>

<http://aubethermostatmanual.com>

Golf course search by state

<http://golfingnear.com>

Email search by domain

<http://emailbydomain.com>

Auto manuals search

<http://auto.somanuals.com>

TV manuals search

<http://tv.somanuals.com>