

# Combat<sup>®</sup>

## Tubular Unit Heaters

### Installation, Commissioning, Operation & Service Manual

Model CTU  
22 to 115



#### FOR YOUR SAFETY

If you smell gas:

1. Open windows.
2. DO NOT try to light any appliance.
3. DO NOT use electrical switches.
4. DO NOT use any telephone in your building.
5. Leave the building.
6. Immediately call your local gas supplier after leaving the building. Follow the gas supplier's instructions.
7. If you cannot reach your gas supplier, call the Fire Department.

#### **WARNING**



#### Fire Hazard

Do not store or use petrol or other flammable vapours and liquids in the vicinity of this or any other appliance.

Some objects will catch fire or explode when placed close to heater.

Failure to follow these instructions can result in death, injury or property damage.

#### **WARNING**

Improper installation, adjustment, alteration, service or maintenance can result in death, injury or property damage. Read the installation, operation and service manual thoroughly before installing or servicing this equipment.

Installation must be done by a registered installer/contractor qualified in the installation and service of gas-fired heating equipment or your gas supplier.

#### Installer

Please take the time to read and understand these instructions prior to any installation. Installer must give a copy of this manual to the owner.

#### Owner

Keep this manual in a safe place in order to provide your serviceman with necessary information.



Quality in Any Language<sup>™</sup>

© Copyright 2007 Roberts-Gordon, LLC

#### Roberts-Gordon Europe Limited

Unit A, Kings Hill Business Park

Darlaston Road, Wednesbury

West Midlands WS10 7SH UK

Telephone: +44(0)121 506 7700

Fax: +44 (0)121 506 7701

Service Telephone: +44 (0)121 506 7709

Service Fax: +44 (0)121 506 7702

E-mail: [uksales@rg-inc.com](mailto:uksales@rg-inc.com)

E-mail: [export@rg-inc.com](mailto:export@rg-inc.com)

[www.rg-inc.com](http://www.rg-inc.com)

P/N X407UK Rev G 10/07



## TABLE OF CONTENTS

<b>SECTION 1: Heater Safety</b> .....	<b>2</b>	<b>SECTION 12: User Instructions</b> .....	<b>28</b>
<b>SECTION 2: Installer Responsibility</b> .....	<b>2</b>	12.1 User Instructions .....	28
2.1 Clearances to Combustibles .....	2	12.2 Heater Operation.....	28
2.2 Corrosive Chemicals.....	2	12.3 Common User Controls.....	28
2.3 National Standards and Applicable Codes .....	2	12.4 Lighting Instructions .....	28
<b>SECTION 3: Critical Considerations</b> .....	<b>3</b>	12.5 Simple Fault Finding.....	29
3.1 Basic Information .....	3	<b>SECTION 13: Servicing</b> .....	<b>30</b>
3.2 Location and Suspension .....	3	13.1 Servicing Instructions.....	30
3.3 Minimum Required Installation Clearances .....	3	13.2 Burner Maintenance.....	30
3.4 Clearances to Combustibles .....	3	13.3 Fan/Motor Assembly Maintenance .....	30
3.5 Ventilation .....	3	13.4 Heat Exchanger Maintenance .....	30
3.6 Gas Supply .....	3	13.5 Gas Control Valve Maintenance .....	30
3.7 Electrical Supply .....	3	13.6 Flue Fan .....	30
3.8 Flue.....	3	<b>SECTION 14: Conversion Between Gases</b> .....	<b>31</b>
<b>SECTION 4: Specifications</b> .....	<b>5</b>	14.1 General .....	31
4.1 CTUA .....	5	14.2 Burner Conversion .....	31
4.2 CTUB, CTUC and CTUD .....	6	14.3 Gas Valves .....	31
4.3 General Technical Data Table .....	7	<b>SECTION 15: Troubleshooting</b> .....	<b>32</b>
4.4 Technical Data Table.....	8	15.1 General .....	32
<b>SECTION 5: Heater Installation</b> .....	<b>9</b>	15.2 Troubleshooting For Automatic Ignition Burner Systems .....	33
5.1 General .....	9	15.3 Troubleshooting for Flame Supervision System .....	34
5.2 Handling .....	9	15.4 Troubleshooting for Solenoid Valves .....	34
5.3 Shelf Mounting and Suspension .....	9	<b>SECTION 16: Removal and Replacement Parts</b> .....	<b>35</b>
<b>SECTION 6: Flue Installation</b> .....	<b>10</b>	16.1 Gas Valve .....	35
6.1 Flue Installation.....	10	16.2 Burner Compartment .....	36
6.2 Type C <sub>12</sub> , C <sub>32</sub> & C <sub>62</sub> Appliance .....	10	16.3 Ignition Electrode and Flame Probe .....	37
6.3 Type B <sub>22</sub> Appliance.....	10	16.4 Flue Fan .....	38
<b>SECTION 7: Air Supply</b> .....	<b>12</b>	16.5 Pressure Switch.....	39
7.1 Room Sealed Installation .....	12	16.6 Ignition Control .....	40
7.2 Open Flued Installation .....	12	16.7 CTUA Axial Fan/Guard/Motor Assembly .....	40
7.3 Building Ventilation .....	12	16.8 CTUB & CTUC Centrifugal Fan/Guard/Motor Assembly.....	40
7.4 Isolated Equipment Rooms .....	12	16.9 Fan Data.....	41
<b>SECTION 8: Optional Heater Configurations</b> .....	<b>13</b>		
8.1 Distribution Duct Work for CTUB, CTUC and CTUD Heaters .....	13		
<b>SECTION 9: Gas Piping</b> .....	<b>14</b>		
9.1 Connections.....	14		
<b>SECTION 10: Wiring and Electrical Information</b> .....	<b>15</b>		
10.1 Electrical Supply .....	15		
10.2 Remote Controls .....	15		
10.3 CTUA Wiring Diagram (Models 22-60) .....	16		
10.4 CTUA Wiring Diagram (Models 75-115) .....	17		
10.5 CTUB/C Wiring Diagram (Models 22-40).....	18		
10.6 CTUB/C Wiring Diagram (Models 50-60).....	19		
10.7 CTUB/C Wiring Diagram (Models 75-115) .....	20		
10.8 CTUD Wiring Diagram (Models 22-60) .....	21		
10.9 CTUD Wiring Diagram (Models 75-115).....	22		
10.10 CTUD External Motor Alternative Wiring & Optional Thermostat/Time Switch .....	23		
<b>SECTION 11: Commissioning</b> .....	<b>24</b>		
11.1 Pre-Commission Checks .....	24		
11.2 Gas Supply .....	24		
11.3 Mechanical Checks.....	24		
11.4 Begin Commissioning .....	24		
11.5 Combustion Testing .....	26		
11.6 Turning Off the Heater .....	26		
11.7 External Controls .....	27		
11.8 Complete the Commissioning.....	27		
11.9 Instruction to the User .....	27		

© 2007 Roberts-Gordon, LLC

All rights reserved. No part of this work covered by the copyrights herein may be reproduced or copied in any form or by any means - graphic, electronic, or mechanical, including photocopying, recording, taping or information storage and retrieval systems - without the written permission of Roberts-Gordon, LLC.



---

## TABLE OF FIGURES

Figure 1: Installation Clearances and Clearances to Combustibles .....	4
Figure 2: Suspension Methods .....	9
Figure 3: Flue and Roof Detail .....	10
Figure 4: Air Intake Terminal Cover .....	10
Figure 5: Vertical and Horizontal Flue Termination - Type B <sub>22</sub> Appliance .....	11
Figure 6: Vertical and Horizontal Flue Termination - Type C <sub>12</sub> C <sub>32</sub> & C <sub>62</sub> Appliances .....	11
Figure 7: Heaters Installed in Isolated Equipment Rooms .....	12
Figure 8: Ducting.....	13
Figure 9: Gas Connection with Stainless Steel Flex Connector .....	14
Figure 10: Automatic Burner Control Box Sequence.....	25
Figure 11: Gas Valve for Heater (Models 22 - 60) .....	25
Figure 12: Gas Valve for Heater (Models 75 - 115) .....	26
Figure 13: Heater Operating Sequence .....	28
Figure 14: Centrifugal Fan Orientation .....	41



---

## Product Approval

ROBERTS GORDON® appliances have been tested and CE certified as complying with the essential requirements of the Gas Appliance Directive, the Low Voltage Directive, the Electromagnetic Compatibility Directive and the Machinery Directive for use on natural gas and LPG when installed, commissioned and maintained in accordance with these instructions.

These instructions refer to appliances designed to operate in the European Union.

Appliances designed for other countries (Non-European Union) are available on request.

This appliance must be installed in accordance with the local and national codes in force and used only in a sufficiently ventilated space, as specified in these instructions.

Before installation, check that the local gas distribution systems, nature of gas and pressure, and adjustment of the appliance are compatible.

**SECTION 1: HEATER SAFETY**

Your Safety is Important to Us!  
This symbol is used throughout the manual to notify you of possible fire, electrical or burn hazards. Please pay special attention when reading and following the warnings in these sections.

Installation, service and annual inspection of heater must be done by a registered installer/contractor qualified in the installation and service of gas-fired heating equipment.

Read this manual carefully before installation, operation, or service of this equipment.

This heater is designed for heating non-residential indoor spaces. Do not install in residential spaces. These instructions, the layout drawing, local codes and ordinances, and applicable standards that apply to gas piping, electrical wiring, venting, etc. must be thoroughly understood before proceeding with the installation.

**SECTION 2: INSTALLER RESPONSIBILITY**

- To install the heater, as well as the gas and electrical supplies, in accordance with applicable specifications and codes. Roberts-Gordon recommends the installer contact a local building inspector, Fire Officer or insurance company for guidance.
- To use the information given in the manual together with the local and national codes to perform the installation.
- To install the heater in accordance with the Clearances to Combustibles of this heater.
- To furnish all needed materials not furnished as standard equipment.
- To plan location of supports, flues and air intakes.
- To provide access to burners for servicing.
- To provide the owner with a copy of this Installation, Commissioning, Operation and Service Manual.
- To never use heater as support for ladder or other access equipment and never hang or suspend anything from heater.
- To ensure that there is sufficient ventilation in the area to comply with the requirements of all relevant local and national codes.

**2.1 Clearances to Combustibles**

In all situations, clearances to combustibles must be maintained. Caution must be used when running the heater near combustible materials such as wood, paper, rubber, etc. A wall tag (P/N 91040028) is on the back cover of this manual as a permanent reminder of the safety instructions and the importance of the required clearances to combustibles. Affix the tag on a wall near the heater.

**2.2 Corrosive Chemicals**
**CAUTION**

**Do not use heater in an area containing corrosive chemicals.**

**Corrosive chemicals will damage the burner and heat exchanger parts.**

**Failure to follow these instructions can result in property damage.**

Roberts-Gordon cannot be responsible for ensuring that all appropriate safety measures are undertaken prior to installation; this is entirely the responsibility of the installer. It is essential that the contractor, the sub-contractor, or the owner identifies the presence of combustible materials, corrosive chemicals or halogenated hydrocarbons\* anywhere in the premises.

\* **Halogenated Hydrocarbons** are a family of chemical compounds characterized by the presence of halogen elements (fluorine, chlorine, bromine, etc.). These compounds are frequently used in refrigerants, cleaning agents, solvents, etc. If these compounds enter the air supply of the burner, the lifespan of the heater components will be greatly reduced. Warranty will be invalid if the heater is exposed to halogenated hydrocarbons.

**2.3 National Standards and Applicable Codes**

All appliances must be installed in accordance with the latest revision of applicable standards and local and national codes. This refers also to the electric, gas and venting installation. Note: Additional standards for installations in public garages, aircraft hangars, etc. may be applicable.



## SECTION 3: CRITICAL CONSIDERATIONS

### 3.1 Basic Information

CTU heaters have automatic ignition burners for ON/OFF operation only.

### 3.2 Location and Suspension

All models:

- Must be installed indoors.
- Must be installed in a level position.
- May be mounted on a shelf of non-combustible material. (See Page 5, Section 4 and Page 9, Figure 2 for support points)
- May be suspended from above (See Page 9, Figure 2) or from wall brackets of sufficient strength to support the heater as listed in the Dimension Data Table on Page 5, Section 4.1. Drop rods must be a minimum of 10 mm diameter mild steel. Four suspension points (M10 nuts) are located on top of the heater.
- Must be installed in a manner which allows the hinged door to be fully opened to provide access to all serviceable components.

### 3.3 Minimum Required Installation Clearances

Clearances around the heater and flue must be as indicated on Page 4, Figure 1, Page 10, Figure 3 through Page 11, Figure 6 to ensure access for servicing, and correct operation.

### 3.4 Clearances to Combustibles

Clearances must be as indicated on Page 4, Figure 1. If clearances to combustibles are not indicated, then installation clearances apply.

### 3.5 Ventilation

It is important to ensure that there is adequate air circulation around the heater to supply air for combustion, ventilation and distribution in accordance with local and national codes.

### 3.6 Gas Supply

It is important that the gas supply pipe is sized correctly to provide the inlet pressure as stated on the heater data plate. The gas supply pipe and electrical connections must not support any of the heater's weight.

### 3.7 Electrical Supply

A permanent 230 V 50 Hz electrical supply is required at the main electrical terminals. The heater also requires suitable energy controls in accordance with Section 10.

### 3.8 Flue

Choose heater siting to allow for the proper location of the flue. Each heater must be fitted with an individual and correctly sized sealed flue system (See Page 10, Section 6).

No other appliance may be connected to the flue.

For room sealed installation, the air intake must be the same size sealed system and the flue/air intake must terminate at an approved concentric wall or roof terminal.

**⚠ WARNING**



**Fire Hazard**

Some objects will catch fire or explode when placed close to heater.

Keep all flammable objects, liquids and vapours the required distance away from the heater.

Failure to follow these instructions can result in death, injury or property damage.

**Figure 1: Installation Clearances and Clearances to Combustibles**

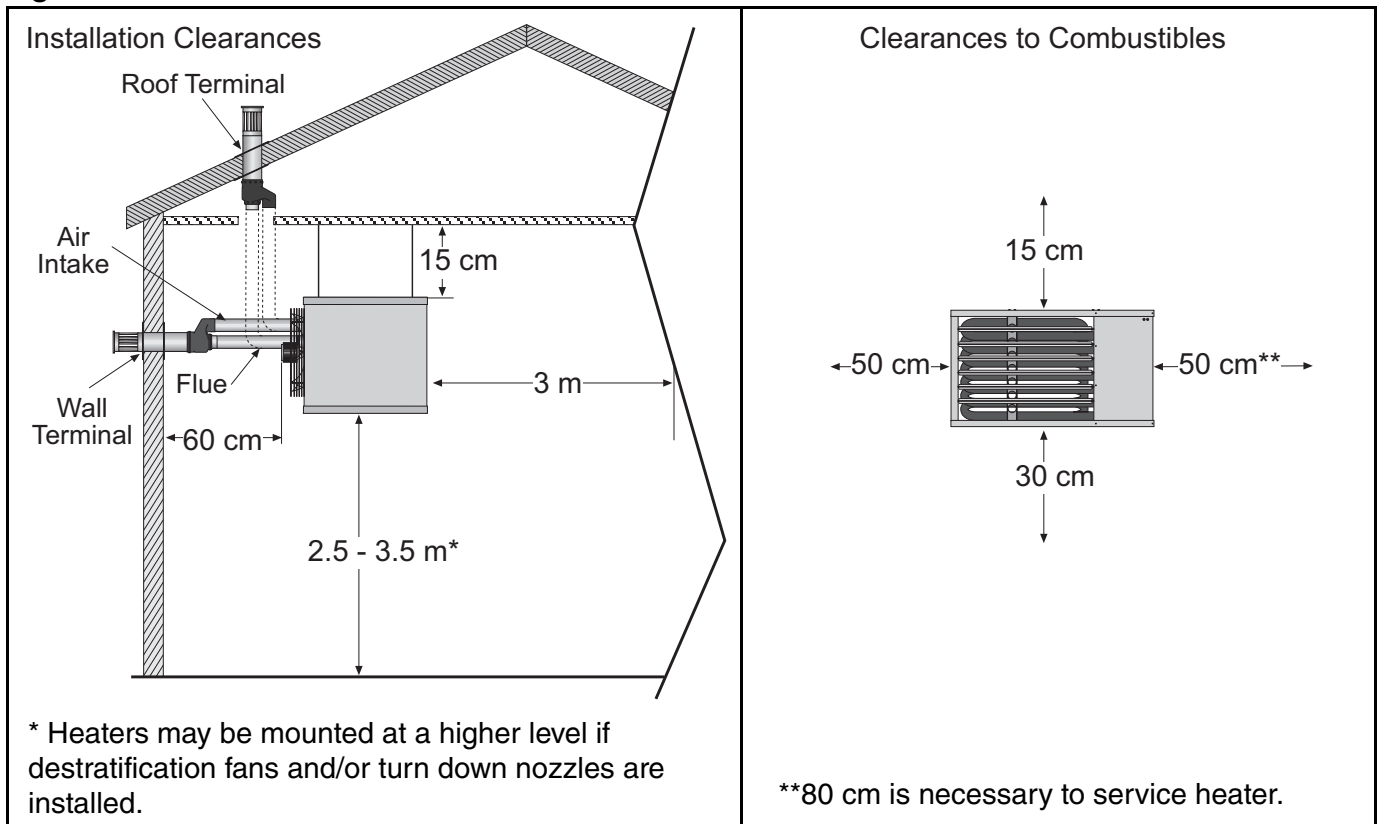

The heater must always be installed at least 2.5 m above the floor.  
The flue pipe must have clearance from combustibles by 5 cm.

If installed at low levels where individuals can come in contact with hot heat exchanger components, adequate guarding must be provided.

All distances are minimum clearance requirements for service access, air flow and safety.

## SECTION 4: SPECIFICATIONS

## 4.1 CTUA

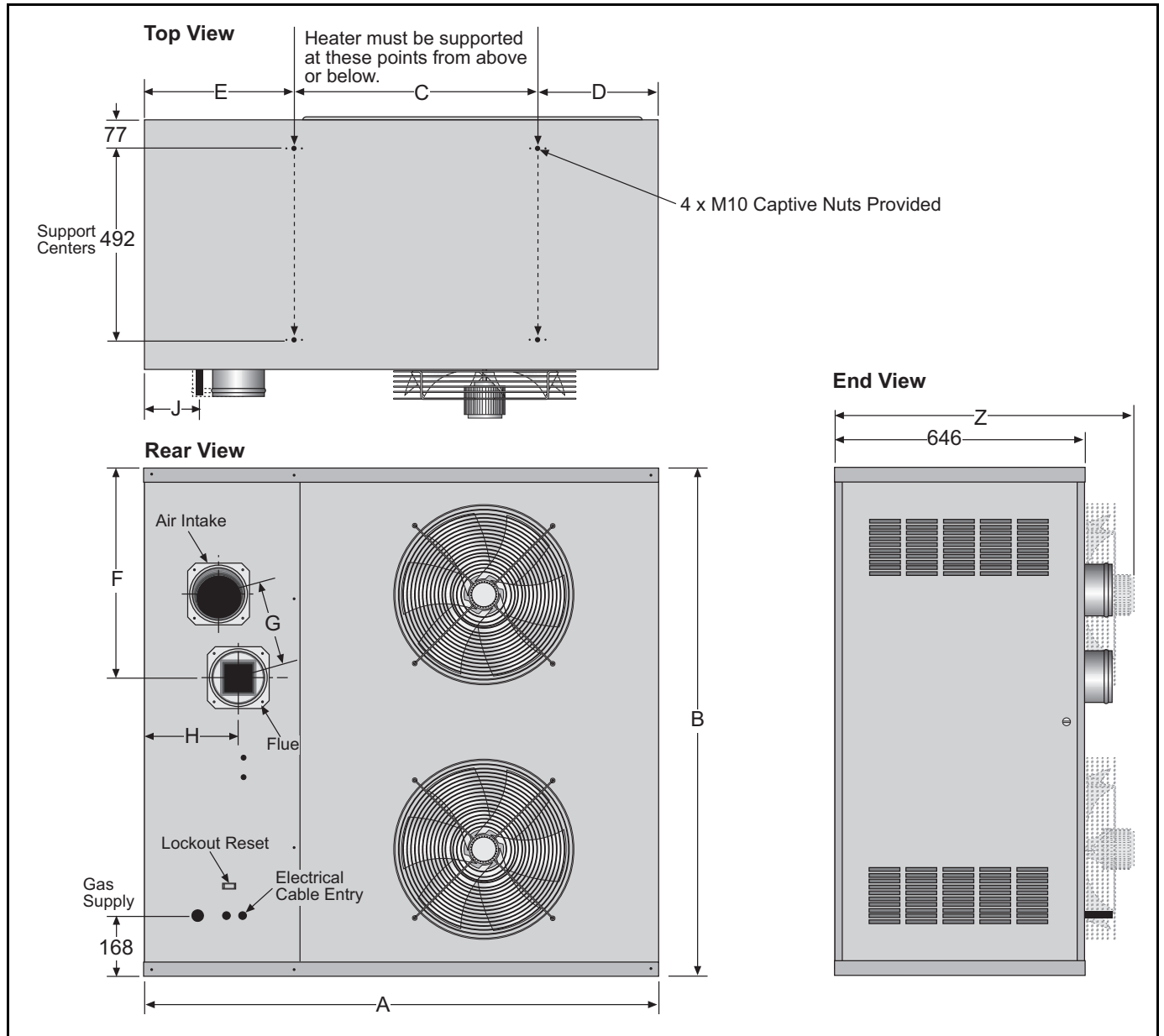

## Dimension Data - CTUA (All Models)

		Model	22	30	35	40	50	60	75	90	100	115
<b>A</b>	Width	mm (in)	1075 (42.3)	1075 (42.3)	1075 (42.3)	1075 (42.3)	1075 (42.3)	1075 (42.3)	1327 (52.3)	1327 (52.3)	1327 (52.3)	1327 (52.3)
<b>B</b>	Height	mm (in)	610 (24)	610 (24)	610 (24)	610 (24)	895 (35.2)	895 (35.2)	1100 (43.3)	1100 (43.3)	1345 (53)	1345 (53)
<b>C</b>	Support Spacing	mm (in)	450 (17.7)	450 (17.7)	450 (17.7)	450 (17.7)	450 (17.7)	450 (17.7)	627 (24.7)	627 (24.7)	627 (24.7)	627 (24.7)
<b>D</b>	Support Spacing	mm (in)	312 (12.3)	312 (12.3)	312 (12.3)	312 (12.3)	312 (12.3)	312 (12.3)	312 (12.3)	312 (12.3)	312 (12.3)	312 (12.3)
<b>E</b>	Support Spacing	mm (in)	315 (12.4)	315 (12.4)	315 (12.4)	315 (12.4)	315 (12.4)	315 (12.4)	388 (15.3)	388 (15.3)	388 (15.3)	388 (15.3)
<b>F</b>	Centre of Flue	mm (in)	240 (9.5)	240 (9.5)	240 (9.5)	240 (9.5)	430 (16.9)	430 (16.9)	346 (13.6)	346 (13.6)	537 (21.1)	537 (21.1)
<b>G</b>	Centre of Flue/Air Intake	mm (in)	140 (5.5)	140 (5.5)	140 (5.5)	140 (5.5)	140 (5.5)	140 (5.5)	225 (8.9)	225 (8.9)	225 (8.9)	225 (8.9)
<b>H</b>	Position of Flue	mm (in)	218 (8.6)	218 (8.6)	218 (8.6)	218 (8.6)	211 (8.3)	211 (8.3)	260 (10.2)	260 (10.2)	260 (10.2)	260 (10.2)
<b>J</b>	Gas Inlet Position	mm (in)	150 (5.9)	150 (5.9)	150 (5.9)	150 (5.9)	150 (5.9)	150 (5.9)	220 (8.7)	220 (8.7)	220 (8.7)	220 (8.7)
<b>Z</b>	Length	mm (in)	756 (29.8)	756 (29.8)	756 (29.8)	756 (29.8)	806 (31.8)	806 (31.8)	756 (29.8)	756 (29.8)	806 (31.8)	806 (31.8)
		mm Ø (in) Ø	100 (3.9)	100 (3.9)	100 (3.9)	100 (3.9)	100 (3.9)	100 (3.9)	130 (5.1)	130 (5.1)	130 (5.1)	130 (5.1)
	Weight	kg	84	84	88	92	115	122	160	169	194	203

4.2 CTUB, CTUC and CTUD

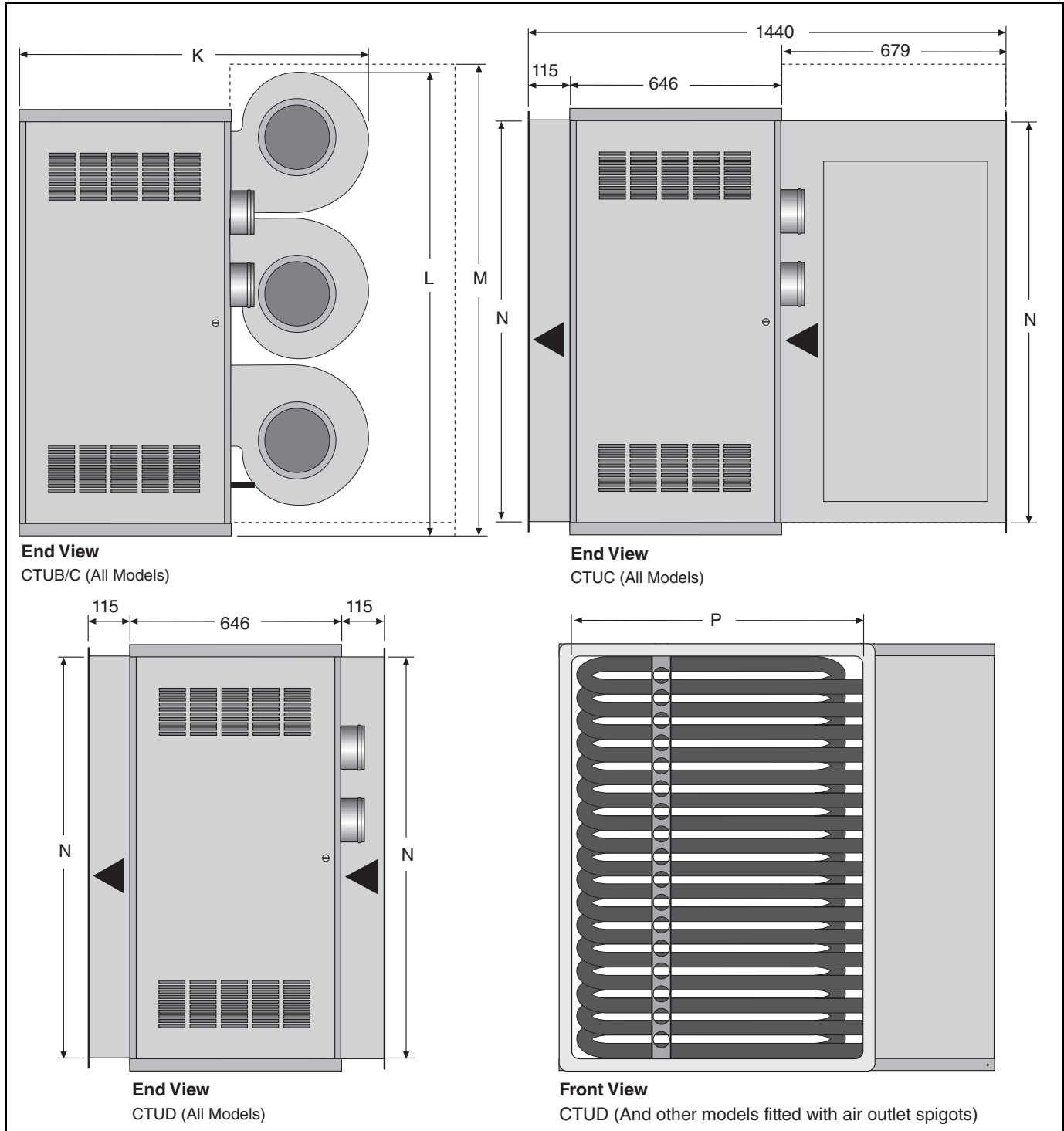

Dimension Data - CTUB, CTUC and CTUD

		Model	22	30	35	40	50	60	75	90	100	115
<b>K</b>	CTUB Depth	mm (in)	1026 (40.4)	1026 (40.4)	1026 (40.4)	1026 (40.4)	1026 (40.4)	1026 (40.4)	1076 (42.4)	1076 (42.4)	1076 (42.4)	1076 (42.4)
<b>L</b>	CTUB Height	mm (in)	610 (24)	610 (24)	610 (24)	610 (24)	895 (35.2)	895 (35.2)	1100 (43.3)	1100 (43.3)	1380 (54.3)	1380 (54.3)
<b>M</b>	CTUC Height	mm (in)	610 (24)	610 (24)	610 (24)	610 (24)	895 (35.2)	895 (35.2)	1100 (43.3)	1100 (43.3)	1431 (56.3)	1431 (56.3)
<b>N</b>	Inlet & Outlet Duct Spigot Height	mm (in)	534 (21)	534 (21)	534 (21)	534 (21)	817 (32)	817 (32)	1024 (40.3)	1024 (40.3)	1233 (48.5)	1233 (48.5)
<b>P</b>	Inlet & Outlet Duct Spigot Width	mm (in)	709 (27.9)	709 (27.9)	709 (27.9)	709 (27.9)	707 (27.8)	707 (27.8)	888 (35)	888 (35)	888 (35)	888 (35)
	Weight CTUB	kg	96	96	100	104	139	146	185	210	228	237
		kg	109	109	113	117	157	163	206	215	251	260
	Weight CTUD	kg	93	93	97	101	124	131	172	181	200	209

**NOTE:** Inlet and outlet duct spigot fitted with 30 mm flange.

## 4.3 General Technical Data Table

		CTU-22	CTU-30	CTU-35	CTU-40	CTU-50	CTU-60	CTU-75	CTU-90	CTU-100	CTU-115
<b>CTUA With Axial Fan</b>											
Total Electrical Load	W	210	210	210	210	415	415	510	510	745	745
Run Current	A	1.0	1.0	1.0	1.0	1.72	1.72	1.9	1.9	3.2	3.2
Start Current	A	1.4	1.4	1.4	1.4	2.4	2.4	2.8	2.8	4.5	4.5
Air Flow	m <sup>3</sup> /h	3800	4000	4000	4000	5500	5500	7500	7500	11,000	11,000
Sound Pressure Level at 3 m	[NR] dB(A)	[51] 56	[51] 56	[51] 56	[51] 56	[52.1] 57.1	[52.1] 57.1	[52.3] 57.3	[52.3] 57.3	[52.3] 57.3	[52.3] 57.3
<b>CTUB with Centrifugal Fan and CTUC Range with Centrifugal Fan and Duct Inlet</b>											
Total Electrical Load	W	550	550	550	550	1100	1100	1100	1100	1650	1650
Normal Run Current	A	4.6	4.6	4.6	4.6	11.0	11.0	11.0	11.0	15.6	15.6
Normal Start Current	A	9.0	9.0	9.0	9.0	13.5	13.5	13.5	13.5	19.2	19.2
Normal Speed		Medium	Medium	Medium	Medium	Medium	Medium	Medium	Medium	Medium	Medium
High Run Current	A	5.5	5.5	5.5	5.5	14.0	14.0	14.0	14.0	21.0	21.0
High Start Current	A	13.6	13.6	13.6	13.6	17.2	17.2	17.2	17.2	25.8	25.8
Air Flow	m <sup>3</sup> /h	3300	3300	3300	3300	5500	5500	6400	6400	9400	9400
Sound Pressure Level at 3 m	[NR] dB(A)	[59] 59.5	[59] 59.5	[59] 59.5	[59] 59.5	[61] 61.5	[61] 61.5	[62] 61.8	[62] 61.8	[63] 64.2	[63] 64.2
<b>CTUD Duct Heater with No Fan</b>											
**Minimum Air Flow Required	m <sup>3</sup> /h	3300	3300	3300	3300	5500	5500	6400	6400	9400	9400
Pressure Loss Across Heat Exchanger	Pa	30	30	30	30	30	30	30	30	30	30
<b>Flue and Air Intake</b>											
Flue and Air Intake Size	mm Ø	100	100	100	100	100	100	130	130	130	130
*Maximum Straight Flue/Air Intake	m	7	8	8	10	13	15	15	17	20	20

Electrical load at 230 V 50 Hz measured by calculating from total run current of appliance.

- \* Do not exceed the maximum length of flue stated or heater may not operate properly. Reduce the maximum length stated by 1 m for each 90° bend installed.
- \*\*If minimum air flow requirements are not met, then temperature limit devices will shut down the heater.

4.4 Technical Data Table

Appliance Category II <sup>2H/L</sup> <sup>3B/P</sup>

		CTU-22	CTU-30	CTU-35	CTU-40	CTU-50	CTU-60	CTU-75	CTU-90	CTU-100	CTU-115
Heat Input Gross CV	kW	27	33	39	48	61	70	95	111	119	134
	(Btu/h) x (1000)	93	113	133	163	210	238	324	378	405	459
Heat Input Net CV	kW	25	30	35	43	55	63	86	100	107	121
	(Btu/h) x (1000)	84	102	119	147	189	215	292	341	365	414
Approximate Heat Output	kW	23	27	32	39	51	58	78	91	98	111
	(Btu/h) x (1000)	78	92	109	133	174	198	266	310	334	379
<b>Thermostat Limit Thermodisc</b>											
CTUA,B/C,D	°C	75	75	75	75	75	75	75	75	75	75
<b>Natural Gas (G20) Data - Inlet Pressure 20 mbar (7.8 in WG) Min. 17 mbar (6.8 in WG) Max. 25 mbar (10 in WG)</b>											
Burner Pressure	mbar	8.3	8.7	8.5	9.4	9.3	8.5	6.1	6.0	6.2	6.3
Gas Rate	m <sup>3</sup> /h	2.6	3.2	3.7	4.5	5.8	6.6	9.0	10.5	11.3	12.8
	ft <sup>3</sup> /h	92	112	131	160	206	234	319	371	398	451
<b>Natural Gas (G25) Data - Inlet Pressure 25 mbar (10 in WG) Min. 20 mbar (7.8 in WG) Max. 30 mbar (12 in WG)</b>											
Burner Pressure	mbar	12.2	12.7	12.5	14.0	13.6	13.2	9.2	9.3	9.2	10.2
Gas Rate	m <sup>3</sup> /h	3.03	3.33	4.31	4.78	6.14	6.98	9.49	11.06	11.86	13.43
	ft <sup>3</sup> /h	107	117	152	169	217	247	335	391	419	474
<b>LPG Gas Propane (G31) Data - Inlet Pressure 37 mbar (14.6 WG) Min. 25 mbar (10 in WG) Max. 45 mbar (18 in WG) Alternative where permitted 50 mbar (20 in WG) Min. 42.5 bar (17 in WG) Max. 57.5 mbar (23 in WG)</b>											
Burner Pressure	mbar	26.6	24.9	25.4	25.9	25.6	26.8	25.6	27.3	25.3	25.9
Gas Rate	m <sup>3</sup> /h	1.01	1.23	1.48	1.77	2.27	2.58	3.51	4.09	4.39	4.97
	kg <sup>3</sup> /h	1.87	2.28	2.75	3.27	4.21	4.79	6.50	7.58	8.13	9.21
	liquid/h	3.7	4.5	5.4	6.4	8.3	9.4	12.8	14.9	16.0	18.1
<b>LPG Gas Butane (G30) Data - Inlet Pressure 29 mbar (11,4 in WG) Min. 20 mbar (7.8 in WG) Max. 35 mbar (13.8 WG)</b>											
Burner Pressure	mbar	18.9	17.4	17.8	19.5	18.4	19.0	18.3	19.4	18.3	18.7
Gas Rate	m <sup>3</sup> /h	0.76	0.93	1.06	1.34	1.72	1.95	2.65	3.09	3.32	3.75
	kg <sup>3</sup> /h	1.86	2.27	2.59	3.26	4.19	4.77	6.47	7.55	8.09	9.17
	liquid/h	3.2	4.0	4.5	5.7	7.3	8.3	11.3	13.2	14.1	16.0

Gas rates corrected to standard conditions 1013.25 mbar 15° C.

## SECTION 5: HEATER INSTALLATION

### 5.1 General

Heaters are designed for installation above 2.5 m. These heaters must be installed within the heated space. Duct delivery systems are not permitted with axial fans.

### 5.2 Handling

All CTU heaters are supplied secured to a wooden pallet and shrink wrapped. Use the pallet to support the heater during handling and installation. When handling or supporting the heater from below, ensure that the weight is taken at the support points.

### 5.3 Shelf Mounting and Suspension

<b>⚠ WARNING</b>	
	<p style="text-align: center;"><b>Crush Hazard</b></p> <p>Use 10 mm steel drop rod minimum.</p> <p>Failure of the supports can result in death, injury or property damage.</p>

For typical suspension See Page 9, Figure 2.

**Figure 2: Suspension Methods**

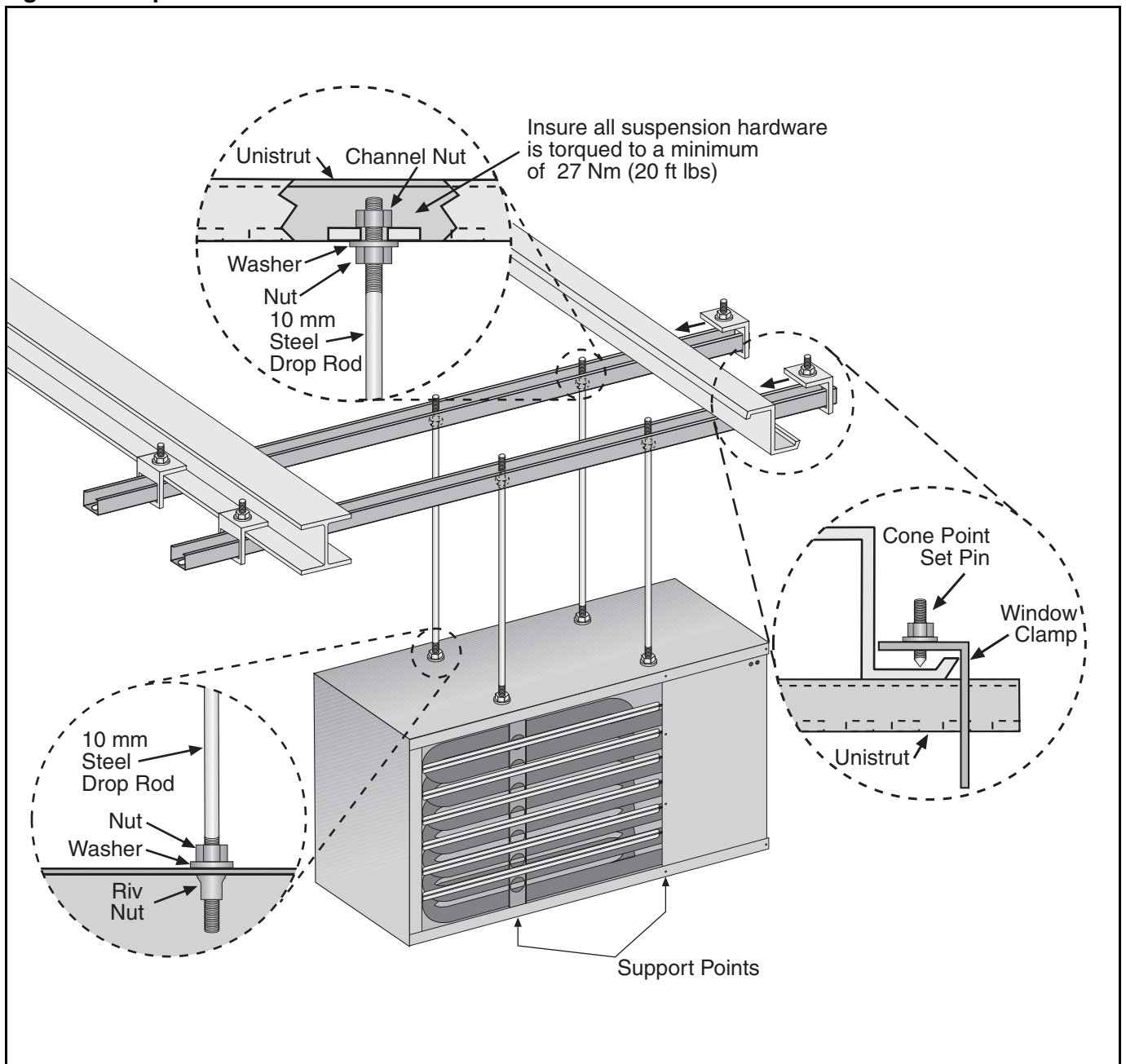

**SECTION 6: FLUE INSTALLATION**

**6.1 Flue Installation**

**⚠ WARNING**



**Fire Hazard**

Some objects will catch fire or explode when placed close to heater.

Keep all flammable objects, liquids and vapours the required distance away from the heater.

Failure to follow these instructions can result in death, injury or property damage.

The flue must terminate outside of the building. Flues and air intakes must be a fully sealed system and correctly sized for the model. Flues should be assembled as detailed on Page 10, Figure 3 through Page 11, Figure 6. The joints between the flue terminal and the roof or wall must be properly sealed. If the flue passes through a wall or ceiling of combustible material, it must be enclosed by a sleeve of non-combustible material and be separated from the sleeve by at least a 25 mm air gap.

**Flues and air intakes must be adequately supported so that the heater does not bear the weight of the pipes.**

For flue termination See Page 10, Figure 3 through Page 11, Figure 6.

**6.2 Type C<sub>12</sub>, C<sub>32</sub> & C<sub>62</sub> Appliance**

Room Sealed.

The heaters are designed to be installed as room sealed appliances. The flue and air intake are run as separate pipes to the special concentric wall or roof terminal. See Page 11, Figure 6.

**6.3 Type B<sub>22</sub> Appliance**

The flue must terminate outside the building and be fitted with a low resistance terminal.

See Page 10, Figure 3 through Page 11, Figure 5.

**6.3.1 Air Intake Terminal Cover**

For Type B<sub>22</sub> appliance installations, an air intake terminal cover is an available option. The cover is scored flat sheet metal that must be bent into shape. See Page 10, Figure 4. Remove and retain the screws for the air inlet spigot. Use these screws to attach the cover in position over the spigot.

**Figure 3: Flue and Roof Detail**

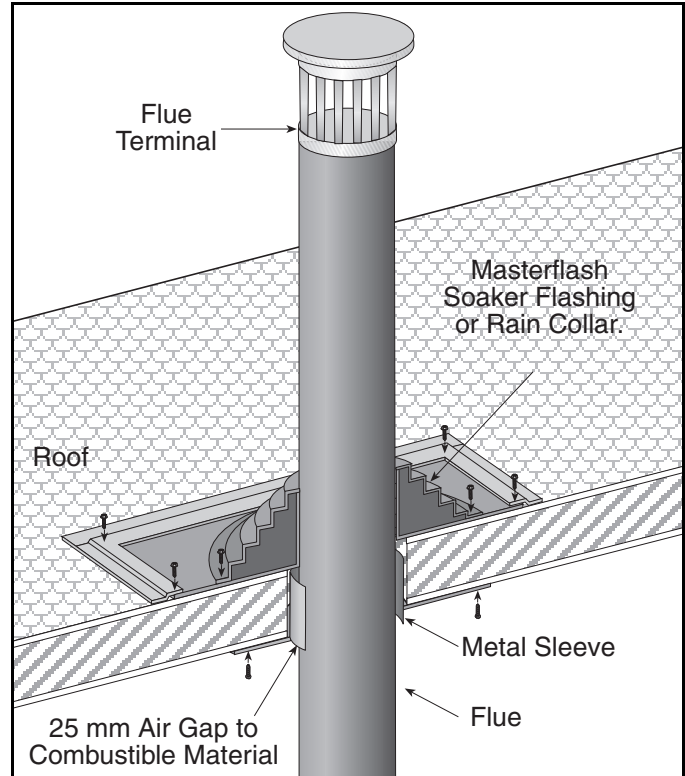

**Figure 4: Air Intake Terminal Cover**

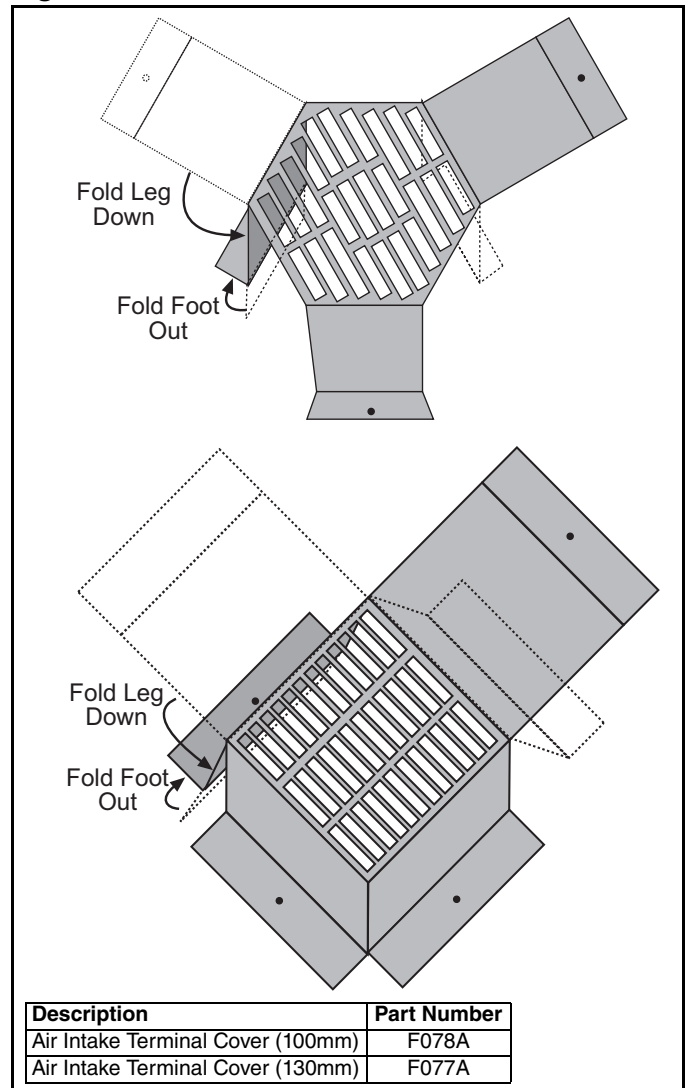
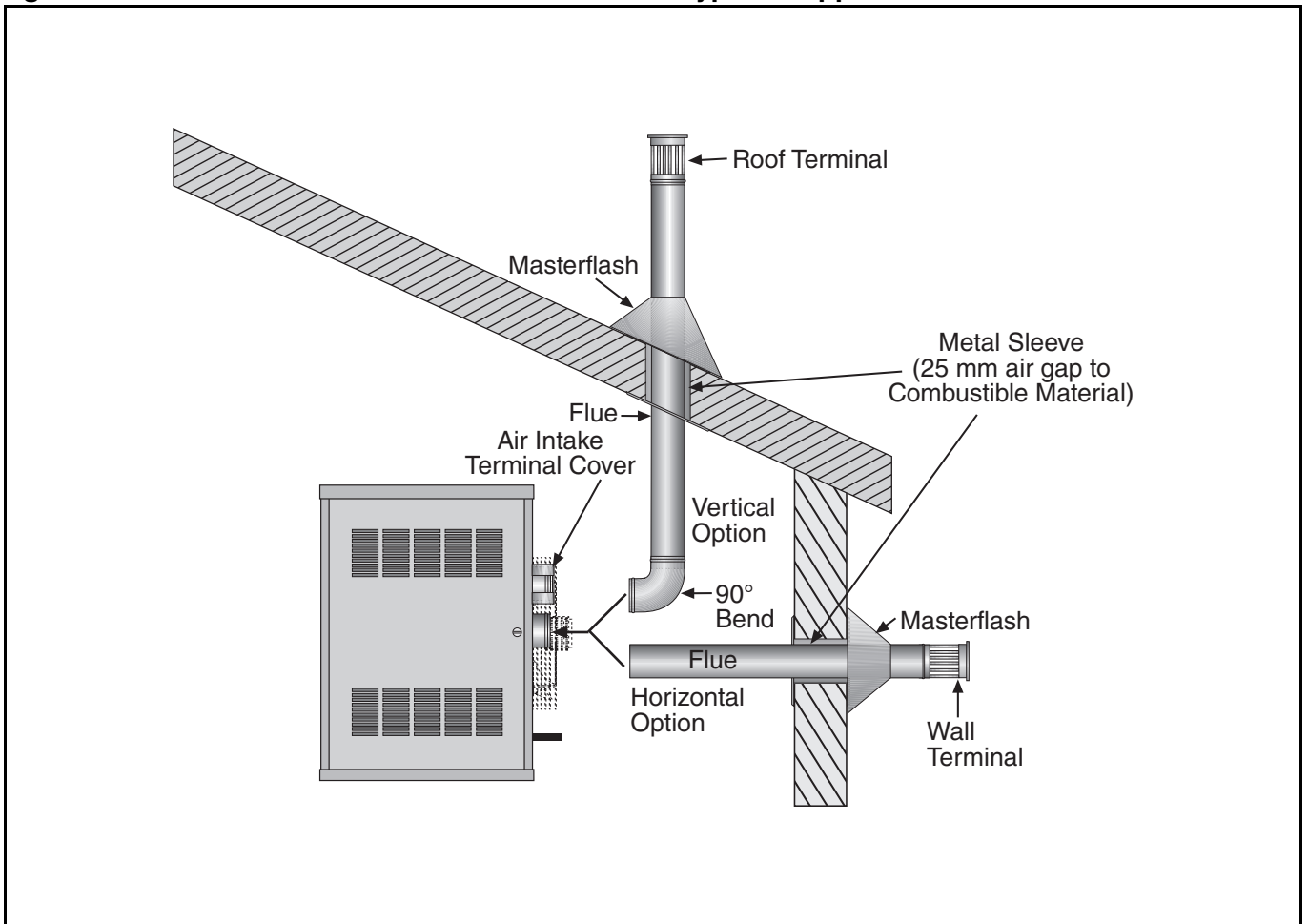
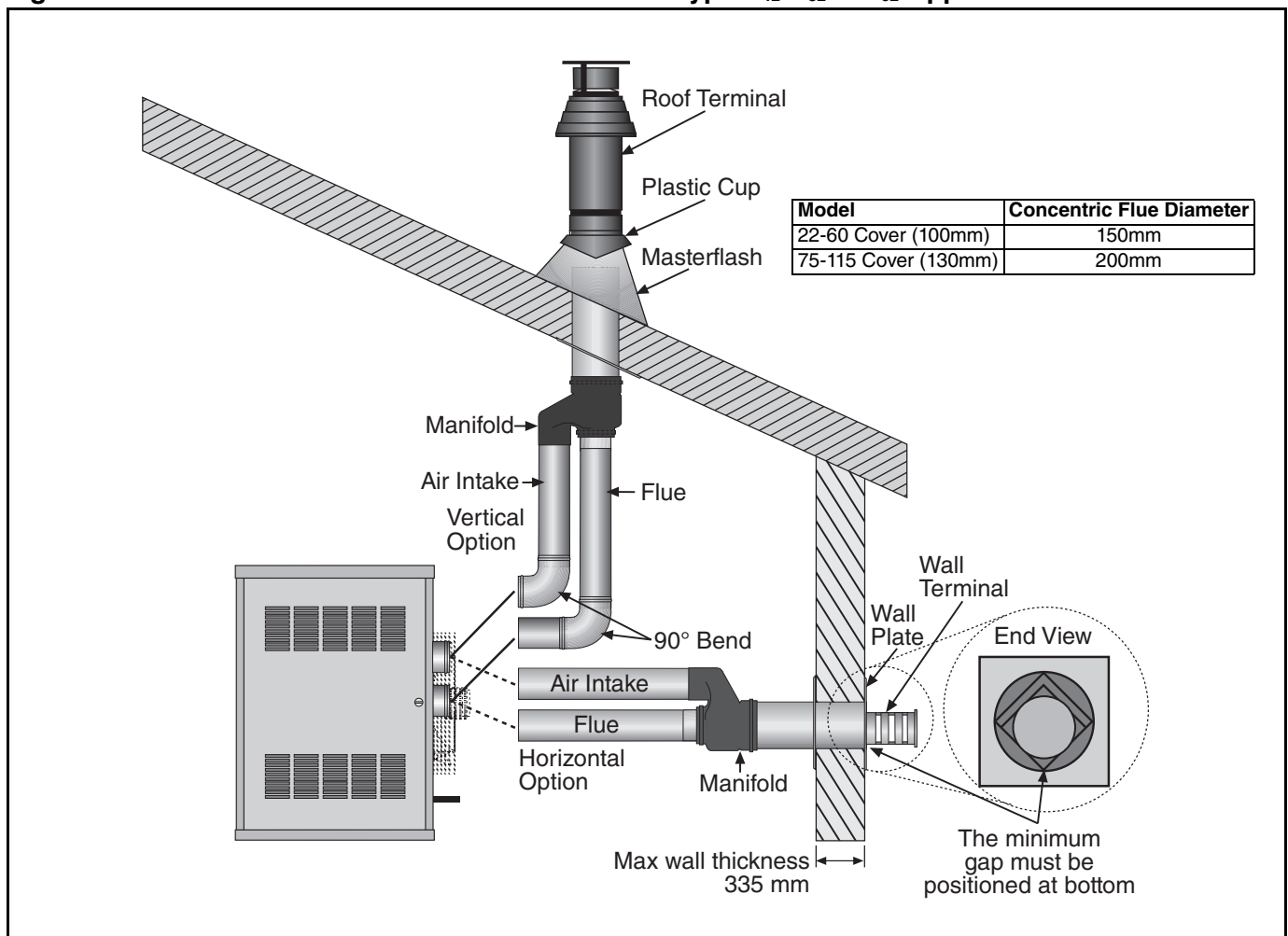



Figure 5: Vertical and Horizontal Flue Termination - Type B<sub>22</sub> ApplianceFigure 6: Vertical and Horizontal Flue Termination - Type C<sub>12</sub> C<sub>32</sub> & C<sub>62</sub> Appliances

**SECTION 7: AIR SUPPLY**

**7.1 Room Sealed Installation**

When installed as a room sealed heater, the air for combustion is drawn in from outside the building. It is important to ensure that there is adequate ventilation to provide air for the distribution fan/s.

**7.2 Open Flued Installation**

It is important to ensure that there is adequate air supply at all times for both combustion and heating requirements in accordance with local and national codes. When installed in this mode, the air supply to the heater must also be fitted with a low resistance terminal to prevent the ingress of debris. See Page 11, Figure 5.

**7.2.1 Heaters Installed Within the Heated Space**

Where the volume of the heated space is greater than 4.7 m<sup>3</sup> per kilowatt of total rated heat input and the air change rate is at least 0.5/h, additional high and low level ventilation will not be required.

For a building having an air change rate less than 0.5/h, ventilation will be necessary in accordance with local and national codes. Ventilation direct to outside must be provided as follows:

- Heaters up to 70 kW heat input: 5.0 cm<sup>2</sup> per kW of rated heat input
- Heaters above 70 kW heat input: 350 cm<sup>2</sup> + 2.5 cm<sup>2</sup> per kW of rated heat input above 70 kW

**7.3 Building Ventilation**

Where ventilation is required, air must be taken from an outside point where it is not likely to be contaminated or obstructed.

Where natural ventilation is used, suitable ventilation with outside air at low level must be provided in accordance with Section 7.2.1 and local and national codes.

Where mechanical ventilation is used, extract rate must be 5% - 10% less than the inlet rate. The mechanical ventilation must be interlocked with the burner on the CTU heater.

**7.4 Isolated Equipment Rooms**

Ventilation must prevent the isolated equipment room temperature from exceeding 32° C as well as prevent any negative air pressure within the room. See Page 12, Figure 7. Any isolated equipment room containing air heaters will require permanent air vents direct to outside air in compliance with local codes.

Where natural ventilation is used, suitable permanent openings at low and high level, communicating directly with the outside air, must be provided.

Where mechanical ventilation is used, extract rate must be 5% - 10% less than the inlet rate. The mechanical ventilation must be interlocked with the burner on the CTU heater.

**Figure 7: Heaters Installed in Isolated Equipment Rooms**

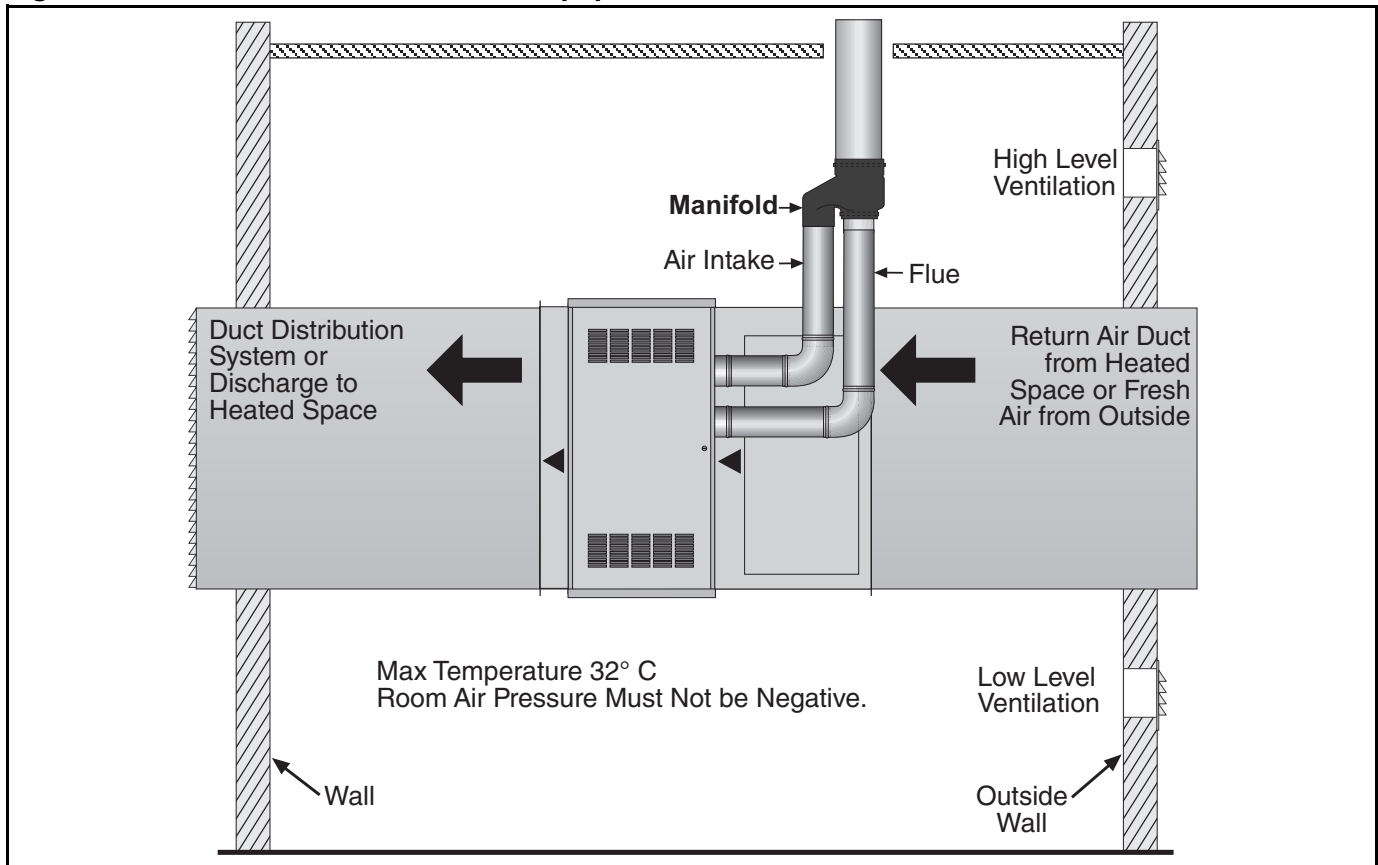

## SECTION 8: OPTIONAL HEATER CONFIGURATIONS

### 8.1 Distribution Duct Work for CTUB, CTUC and CTUD Heaters

CTUC heaters have the fans enclosed so that the heater may be connected to inlet ducting.

CTUD heaters are supplied with inlet and outlet duct spigots for mounting the heater into a customer designed duct system for use with an external fan system.

It is recommended that flexible duct connectors are used to reduce duct born noises.

When installing CTUD heaters onto ducting force the fan to run.

Do not rely on the fan thermostat to turn it on.

Any such device must be in parallel with the fan thermostat so that the fan run-on operation will still operate.

**Contact Roberts-Gordon Europe Ltd. Design Department for recommendations regarding duct resistance and design. Tel: +44 (0) 121 506 7700**

### 8.1.1 CTUD Heaters

For CTUD heaters, it is essential that the airflow in the duct system is at least that specified in the Data Sheet on Page 6, Section 4.2 and in the correct direction across the heat exchanger as indicated by the arrow on the heater. Higher air flows are permitted, but will cause a lower exiting air temperature. It is recommended that the fan is positioned to blow the air through the heat exchanger.

The duct must be designed as described on Page 13, Section 8.1 and Figure 8 to ensure that there is a homogenous air flow across the whole of the heat exchanger.

Failure to provide a suitable air flow properly distributed across the heat exchanger will reduce the life of the heat exchanger.

The fan motor, or its control, must contain a method of overload protection. When installed remote from the heater, the fan must be supplied via a local electrical isolator positioned and properly labeled to prevent inadvertent operation.

**Figure 8: Ducting**

**NOTE:** Duct size will be full size of inlet and outlet.  
All joints between the heater and duct work should be made as air tight as possible.

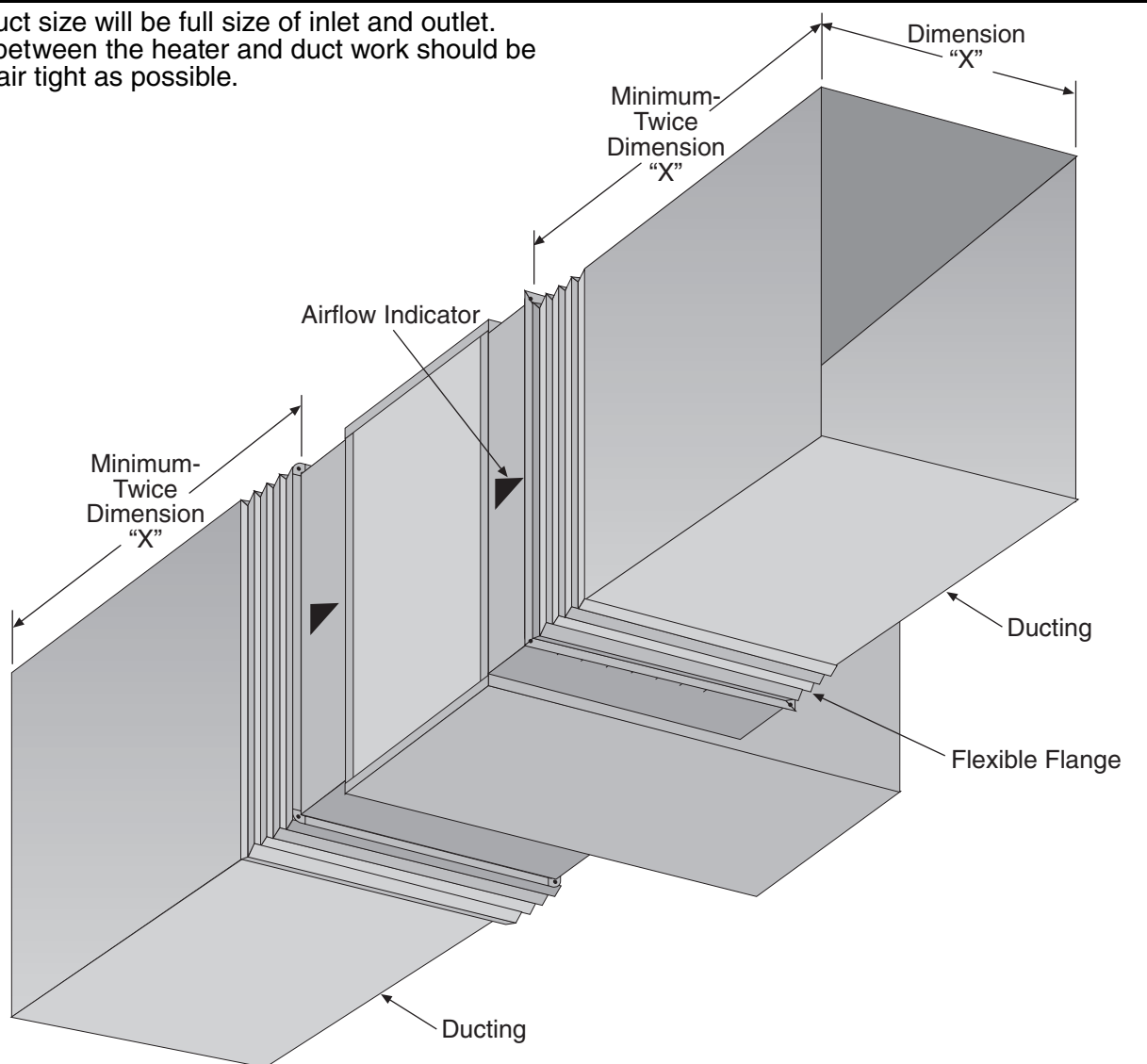

SECTION 9: GAS PIPING

**⚠ WARNING**



**Fire Hazard**

**Connect gas supply according to Figure 9.**

**Gas can leak if not installed properly.**

**Failure to follow these instructions can result in death, injury or property damage.**

It is important that the gas supply pipe and the electrical connections do not support any of the heater's weight.

A gas meter is connected to the service pipe by the gas supply company. An existing meter should be checked, preferably by the company, to ensure that the meter is adequate for the rate of gas supply required.

Installation pipes must be fitted in accordance with local and national codes. Pipe work from the meter to the heater(s) must be of adequate size. Pipes of smaller size than the heater inlet gas connection should not be used.

**9.1 Connections**

Connect the heater to the gas supply ensuring that the final connections are as follows:

- Gas supply pipe work is run in medium or heavy gauge tubing in compliance with local and national codes.
- The gas supply pipe is adequately sized to carry the total volume of gas for the complete installation.
- An isolating valve and union connection should be used and fitted into the supply adjacent to the heater.
- For suspended heaters, use an approved metal flexible connection between the isolating valve and the heater. **To reduce pressure loss, use one pipe size larger than the heater gas connection.**

**IMPORTANT** - The complete installation must be purged and tested for gas soundness in accordance with local and national codes.

**Figure 9: Gas Connection with Stainless Steel Flex Connector**

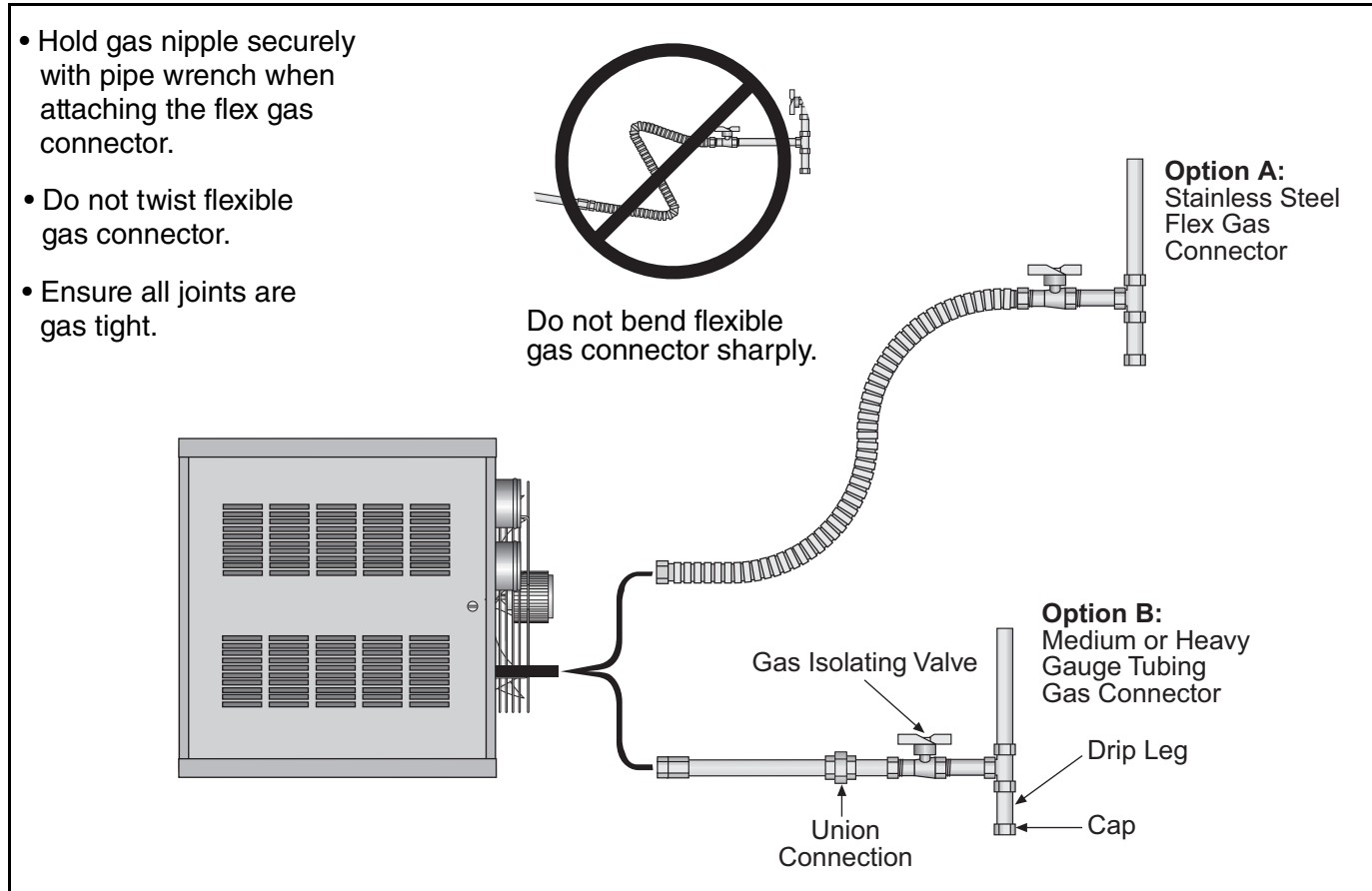

**SECTION 10: WIRING AND ELECTRICAL INFORMATION****10.1 Electrical Supply**

All heaters need a constant 230 V 50 Hz single phase supply connected to terminals L, N & Earth. Polarity "L & N" must be correct. The voltage between neutral and earth should be 0 and never exceed 15 volts.

All heaters and controls must be correctly earthed.

All external wiring must comply with the relevant local codes. Wire specification H05VV-F.

External controls must have the same constant 230 V 50 Hz supply.

An isolator with a contact separation of at least 3 mm on all poles must be installed adjacent to, but not attached to, the heater to disconnect all supplies to the heater and any remote control.

The final connection to the heater should be made by flexible cable or conduit to the main terminal block on the inside of the heater using 1 mm<sup>2</sup> cable on all models.

<b>Models</b>	<b>Fuse Size</b>
CTUA (All Models)	5 A
CTUB & CTUC (Models 22-50)	10 A
CTUB & CTUC (Models 75 - 115)	20 A

CTUD heaters must have the external fan, or its control connected to Terminal 1 so that the fan run-on function at close down operates correctly.

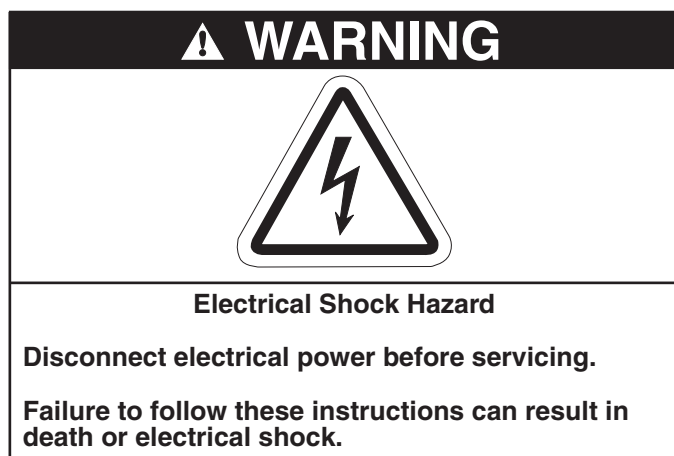
**10.2 Remote Controls**

The heater is designed to be operated by controls installed remote from the heater. See Page 16, Section 10.3. through Page 17, Section 10.4.

**10.2.1 Burner Controls (Thermostat)**

Controls to operate the burner must be voltage free contacts connected between terminals 2 & 3 of the main terminal block.

**10.2.2 Positioning Room Thermostats or ROBERTS GORDON® Control**

A room thermostat or ROBERTS GORDON® control should be mounted on a wall or column at a height of approximately 1.5 metres from the floor to measure the ambient temperature. It should be clear of both cold draughts and the direct path of warm air from the heater.

**10.2.3 Remote Frost Thermostat**

When required, connect to terminals 2 and 3 in the main terminal block.

Locate within the heated space adjacent to the most vulnerable equipment that requires protection.

See Page 16, Section 10.3 through Page 17, Section 10.4.

**10.2.4 Remote Fan Controls**

The fan will operate automatically providing there is a constant 230 V supply to the main terminals.

A switch or control wired between terminals L & 1 in the terminal block will allow external control of the fan(s).

The fan may be controlled to operate continuously from an external control, with the burner cycling on and off, providing that the fan run-on at close down is not impaired.

10.3 CTUA Wiring Diagram (Models 22-60)

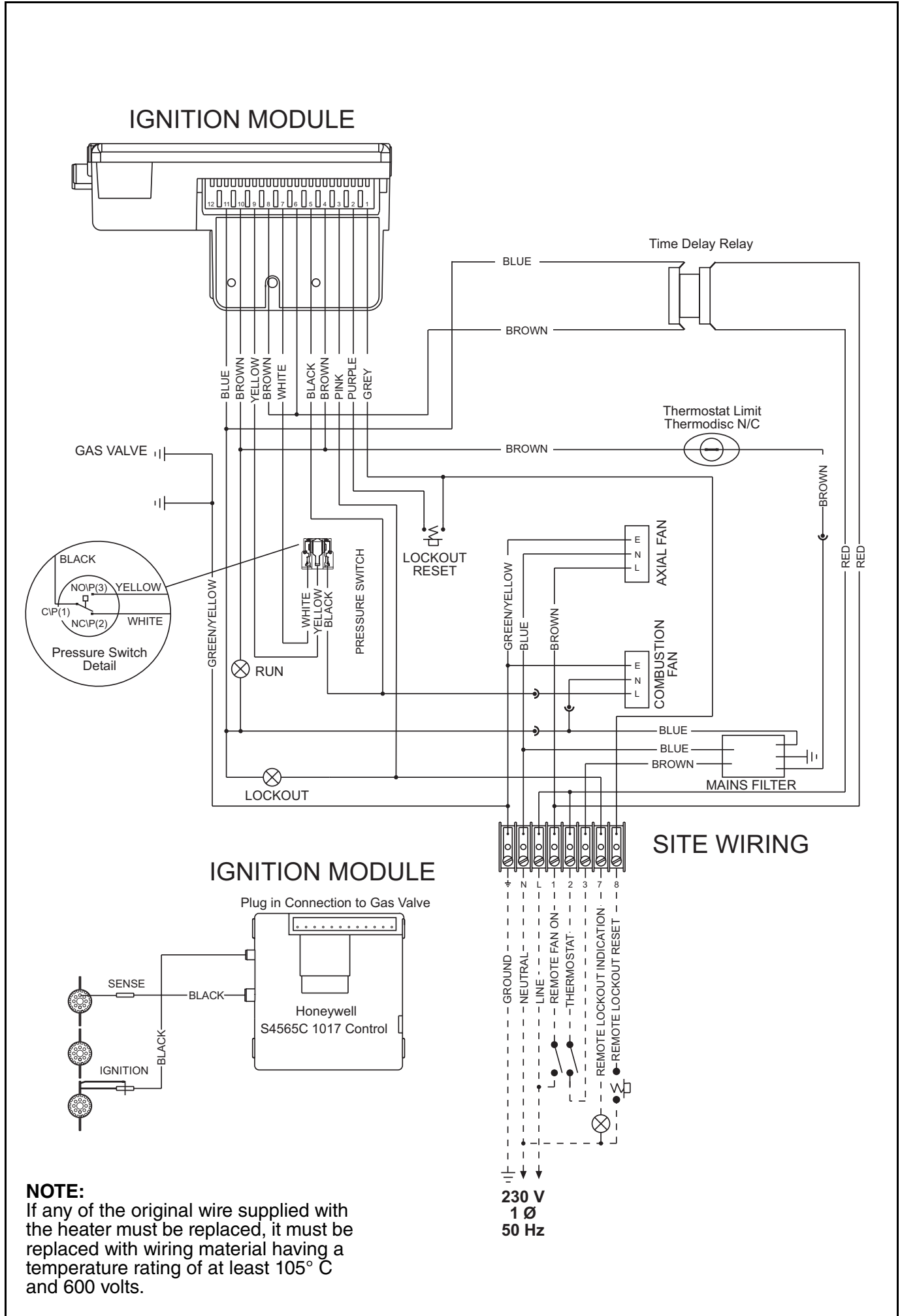

10.4 CUA Wiring Diagram (Models 75-115)

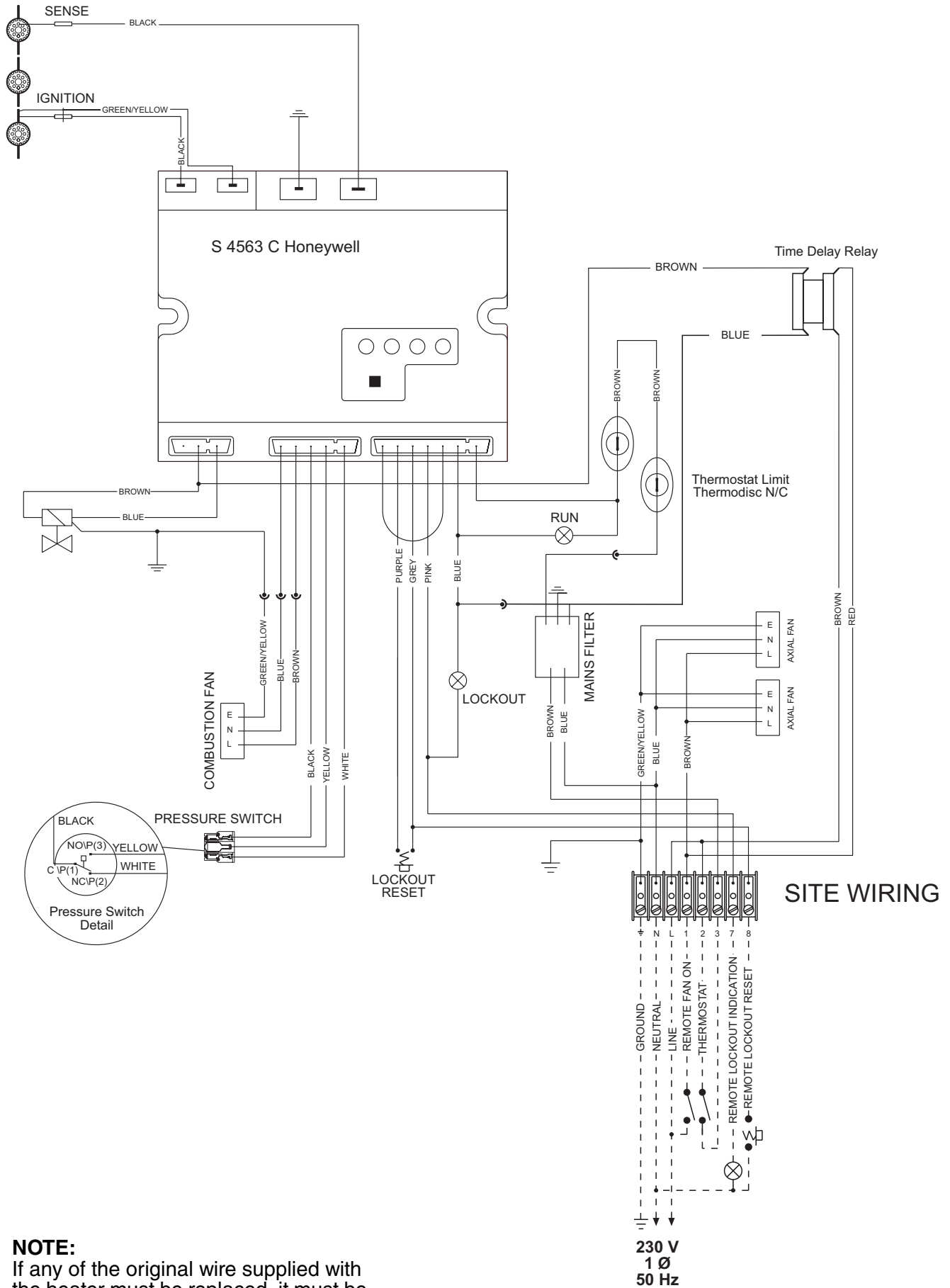

**NOTE:**  
 If any of the original wire supplied with the heater must be replaced, it must be replaced with wiring material having a temperature rating of at least 105° C and 600 volts.

10.5 CTUB/C Wiring Diagram (Models 22-40)

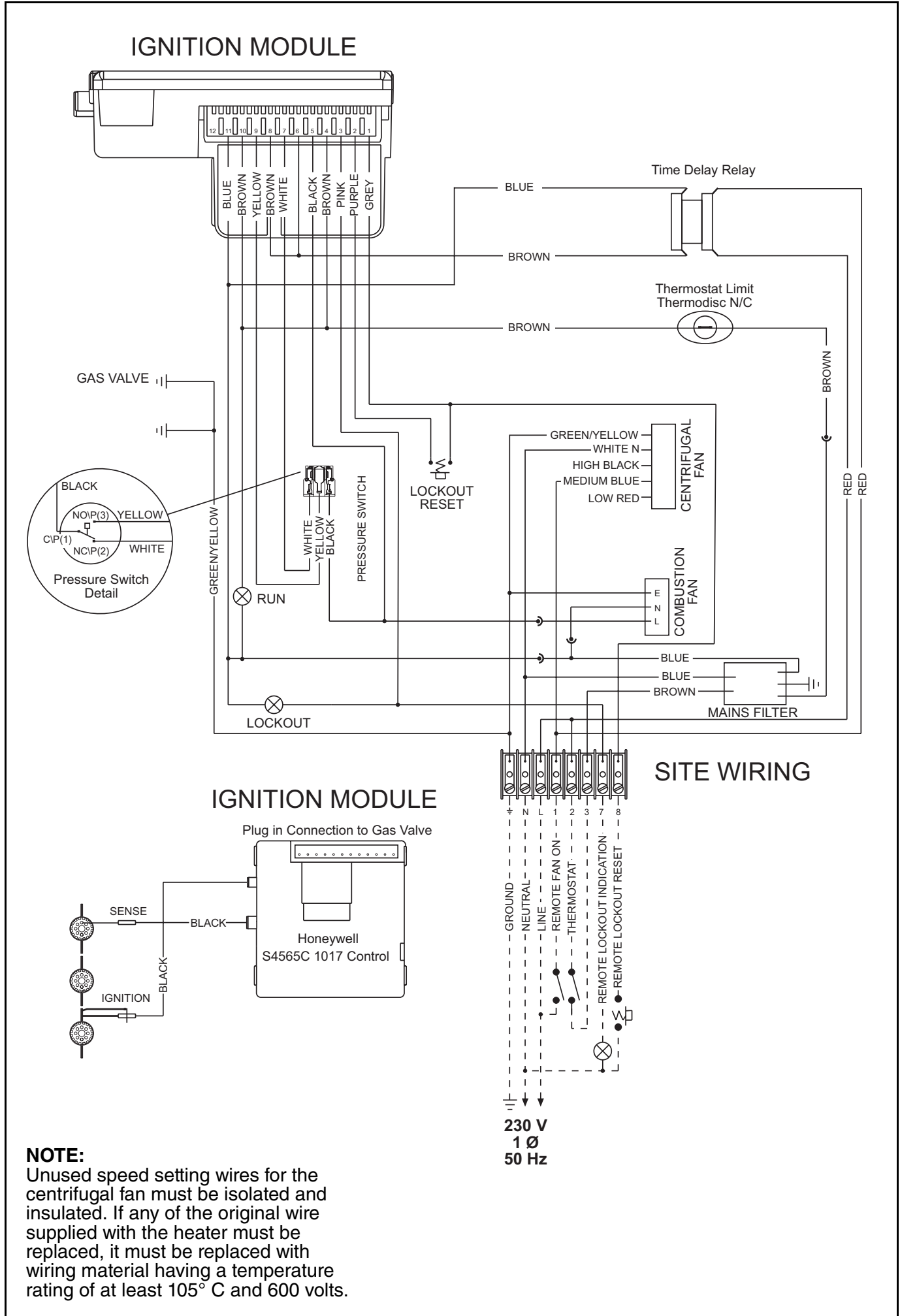

**NOTE:**  
Unused speed setting wires for the centrifugal fan must be isolated and insulated. If any of the original wire supplied with the heater must be replaced, it must be replaced with wiring material having a temperature rating of at least 105° C and 600 volts.



10.6 CTUB/C Wiring Diagram (Models 50-60)

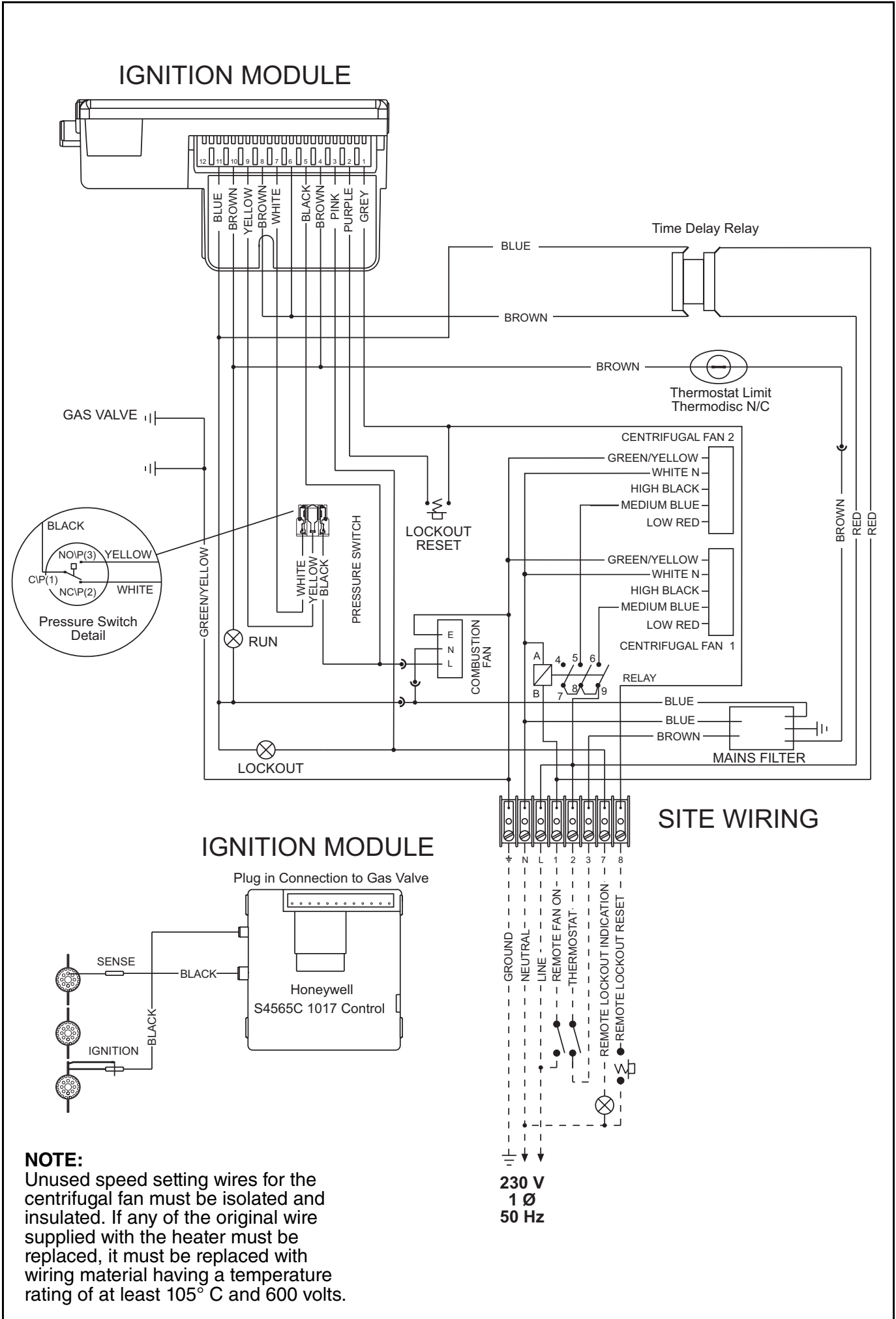

**NOTE:**  
 Unused speed setting wires for the centrifugal fan must be isolated and insulated. If any of the original wire supplied with the heater must be replaced, it must be replaced with wiring material having a temperature rating of at least 105° C and 600 volts.

10.7 CTUB/C Wiring Diagram (Models 75-115)

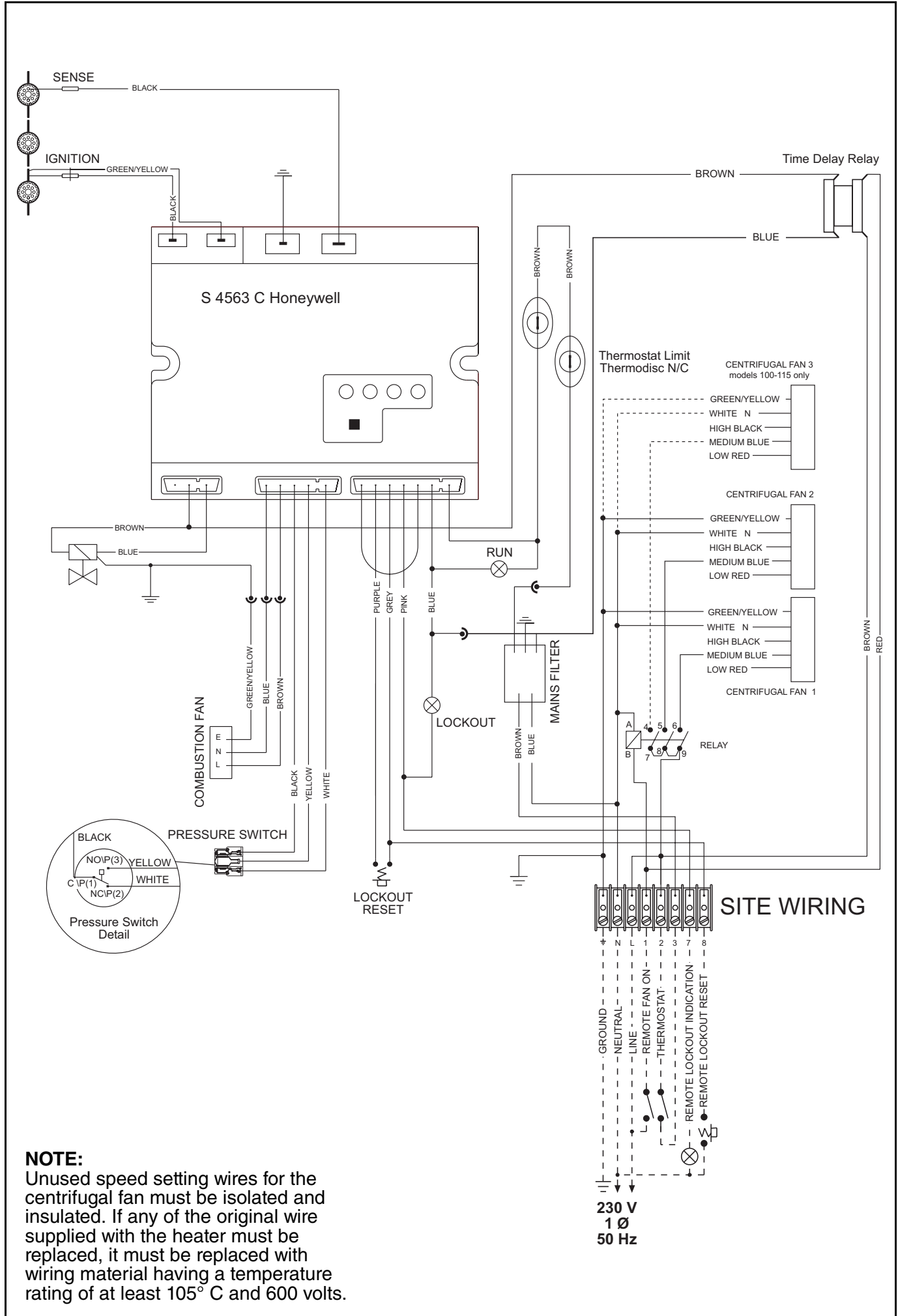

10.8 CTUD Wiring Diagram (Models 22-60)

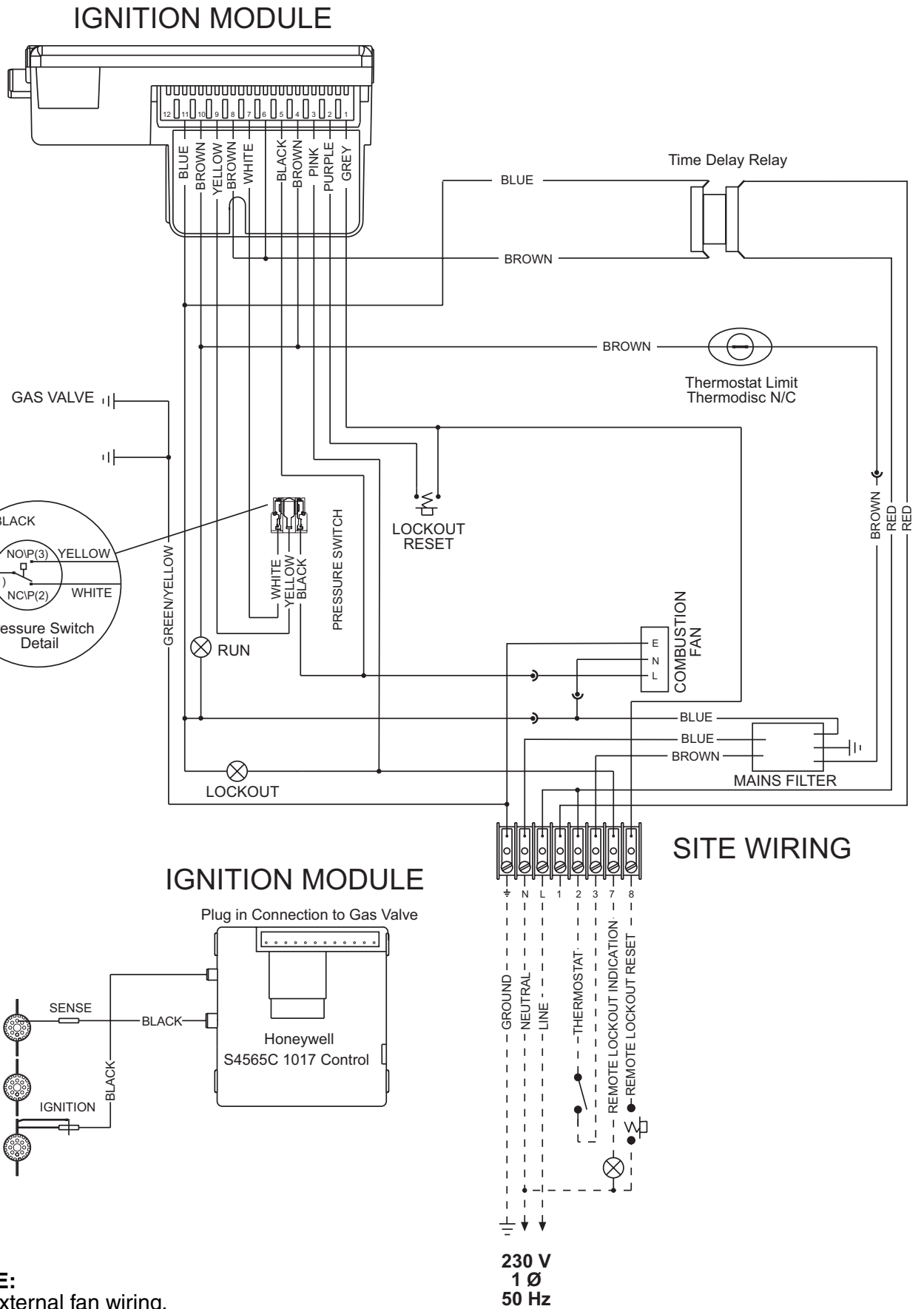

**NOTE:**  
For external fan wiring,  
See Page 23, Section 10.10.

If any of the original wire supplied with the heater must be replaced, it must be replaced with wiring material having a temperature rating of at least 105° C and 600 volts.

10.9 CTUD Wiring Diagram (Models 75-115)

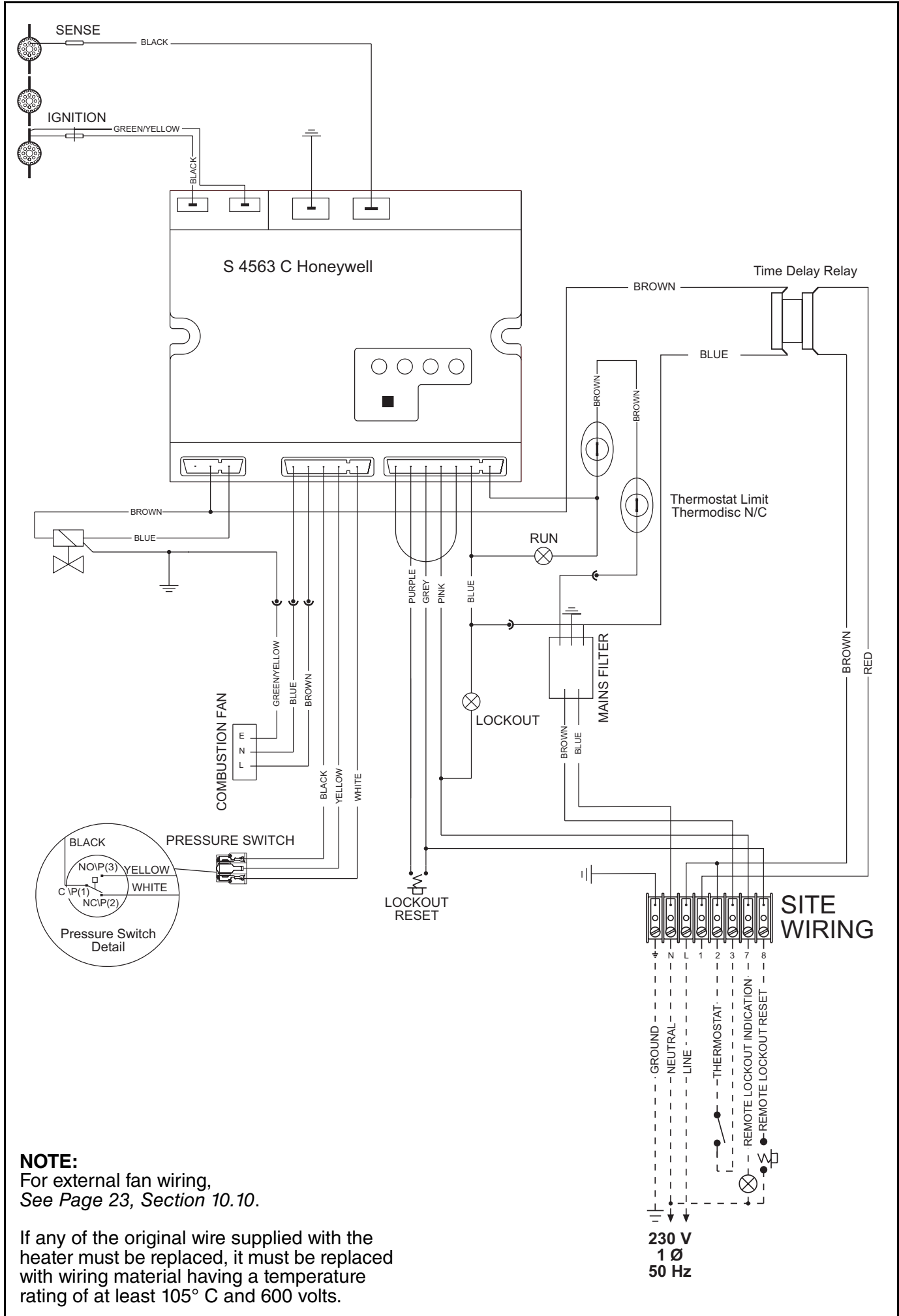

10.10 CTUD External Motor Alternative Wiring & Optional Thermostat/Time Switch

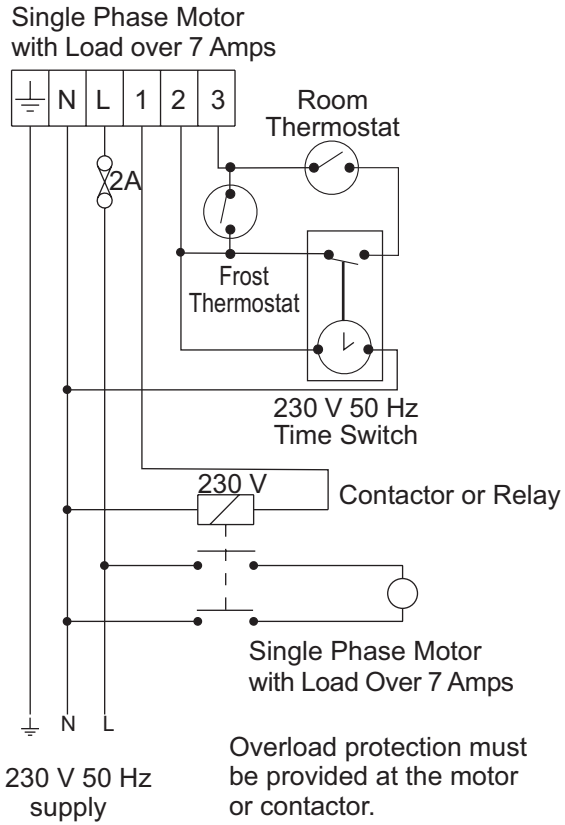

RDW 1565

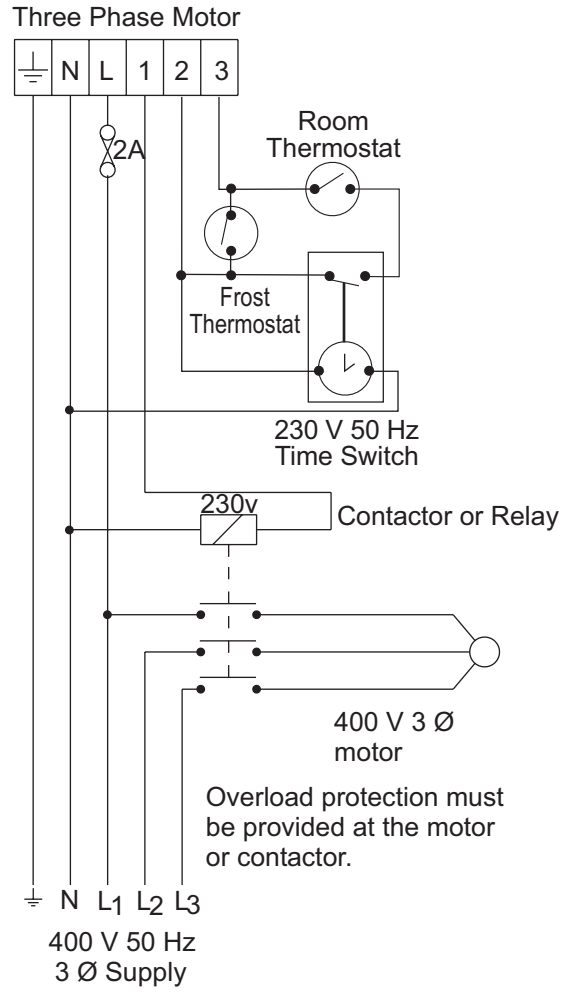

## SECTION 11: COMMISSIONING

Installation, service, commissioning and annual inspection of the heater must be done by a contractor qualified in the installation and service of gas-fired heating equipment. Read this manual carefully before installation, commissioning, operation, or service of this equipment. All components are accessed via the hinged door secured by a ¼ turn latch. Opening the door exposes live electrical connections and hot components.



### 11.1 Pre-Commission Checks

**All pre-commission checks must be carried out before lighting the heater.**

Ensure that the heater and all controls are suitable for the gas, pressure and electrical supply to which they are to be connected.

#### 11.1.1 Louvres

Where fitted, the air delivery louvres need to be set during commissioning to give the required air distribution.

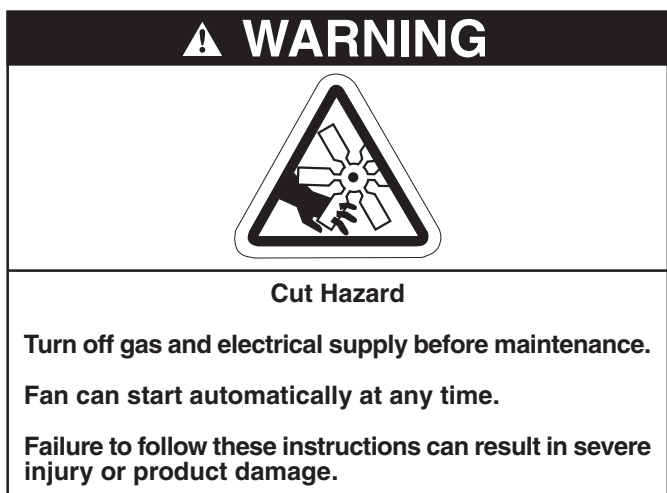

### 11.1.2 Electrical Checks

All pre-commission checks must be carried out before commissioning the heater.

1. Check that all site wiring is connected in accordance with the appropriate wiring diagrams on *Page 16, Section 10.3 through Page 23, Section 10.10*.
2. Check the correct fuse size is fitted; See *Page 15, Section 10.1*.

### 11.2 Gas Supply

All aspects of the gas installation including the gas meter must be inspected, tested for soundness and purged in accordance with local and national codes. Ensure that the air is fully purged from the heater inlet pipe up to the main gas valve inlet test nipple.

### 11.3 Mechanical Checks

1. Check that the fan(s) are free to run and delivery louvres are turned to give required air deflection.
2. Check that the flue (and air intake for room sealed) is installed in accordance with these instructions and local regulations.
3. The thermostat limit thermoswitch is preset and sealed at the factory and is not adjustable.

### 11.4 Begin Commissioning

#### 11.4.1 Before Operating the Heater

To ensure that all the controls are in safe working order, operate the heater for the first time with the isolating gas valve turned off.

1. Turn off the gas isolating valve
2. Using the installed external control, turn on the burner. The automatic sequence will now begin as described on *Page 25, Figure 10*.

There will be no ignition of the burner and lockout will occur, which proves the controls are operating correctly.

**Figure 10: Automatic Burner Control Box Sequence**

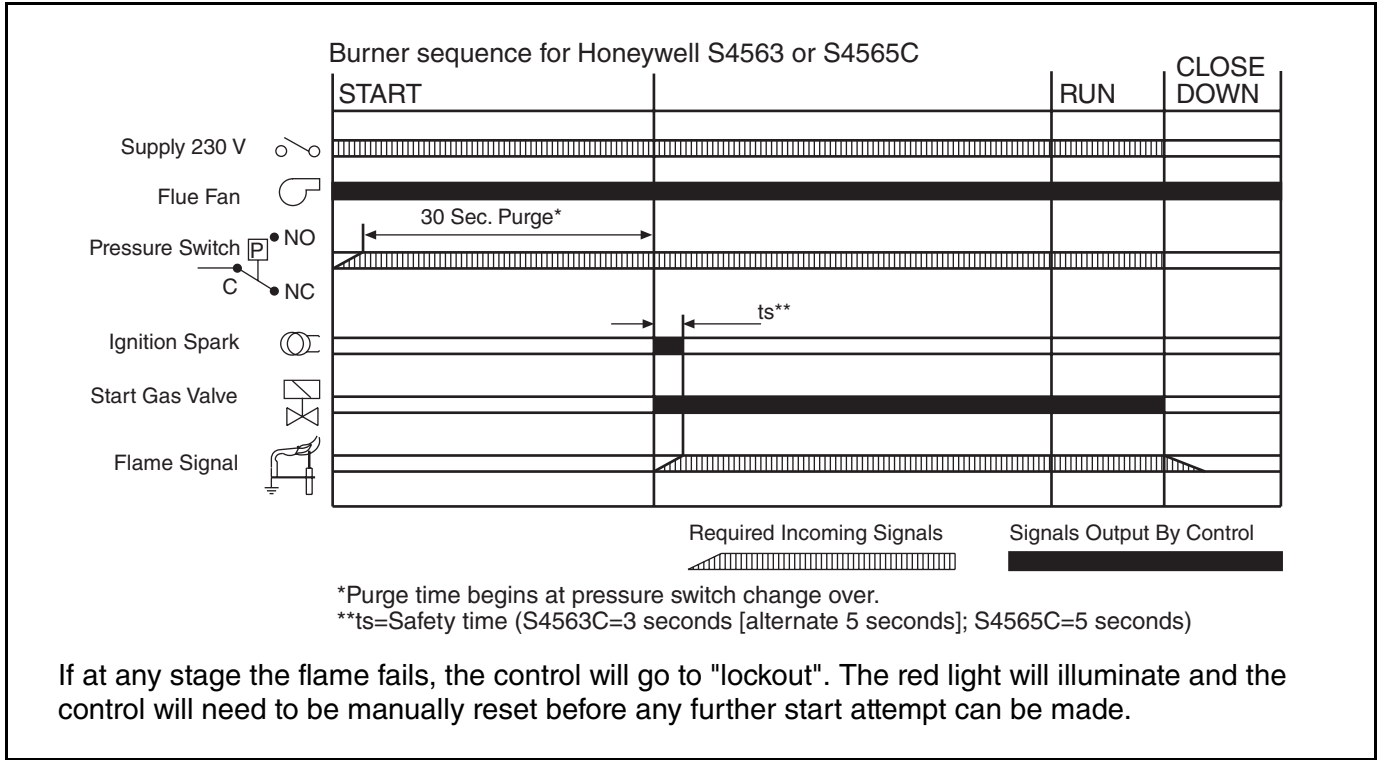

**Figure 11: Gas Valve for Heater (Models 22 - 60)**

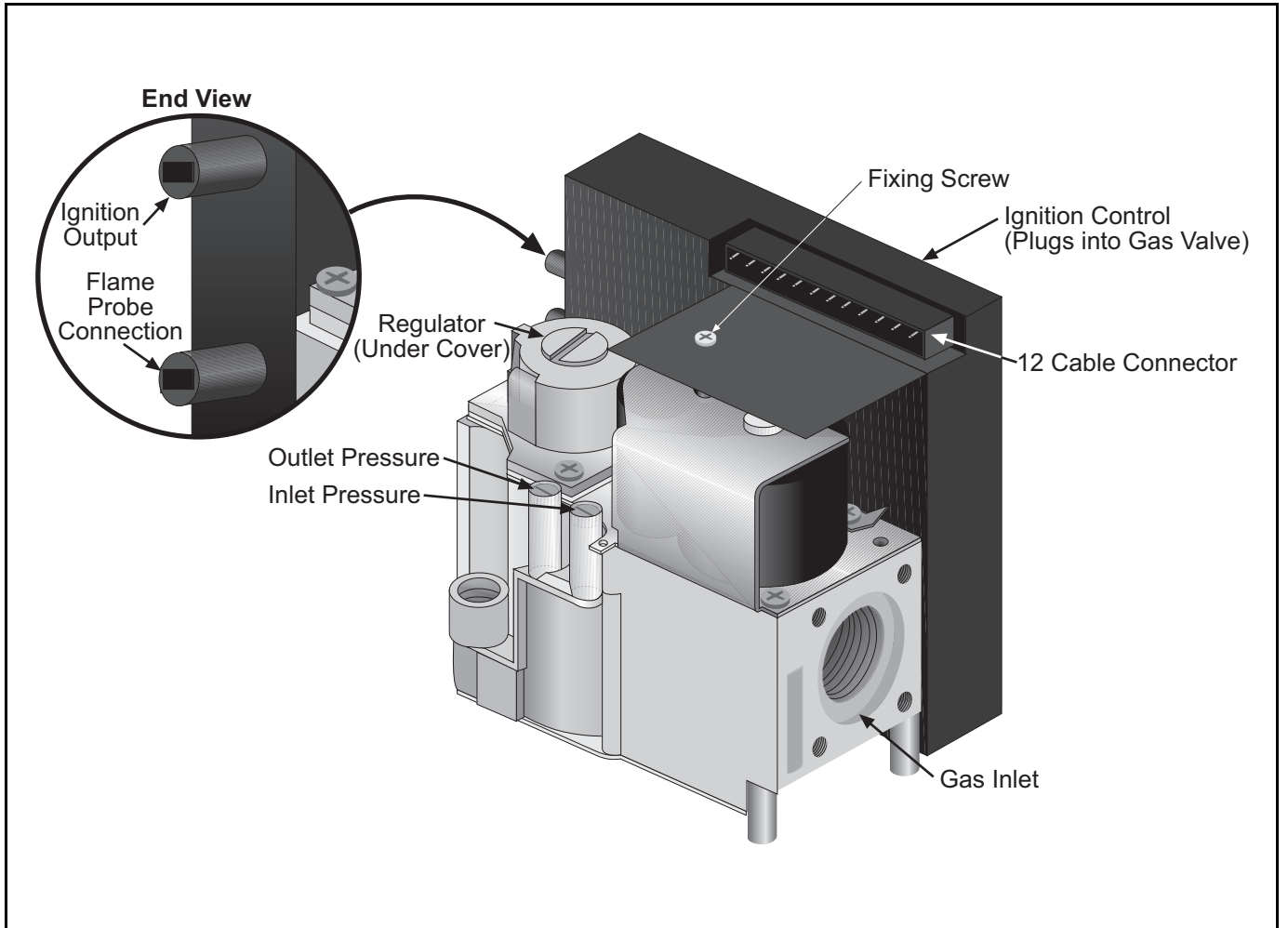

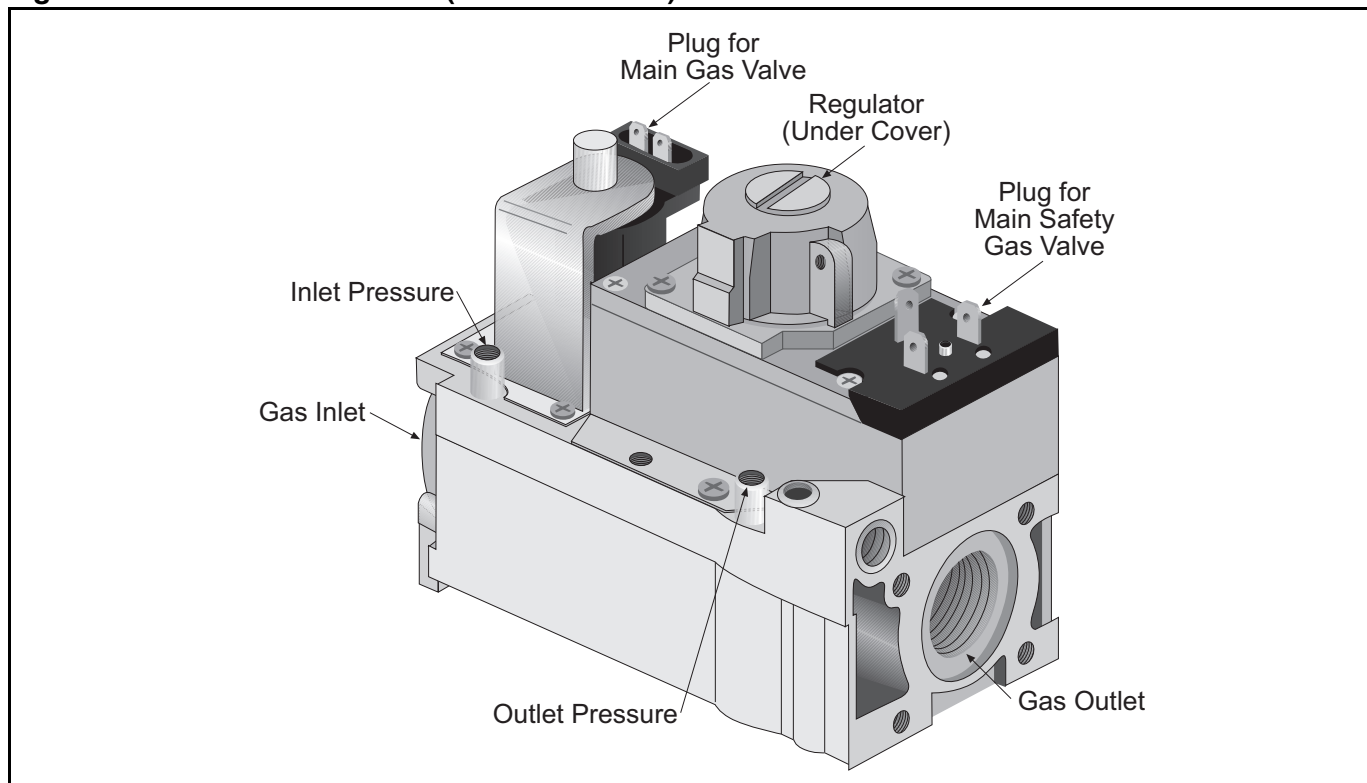
**Figure 12: Gas Valve for Heater (Models 75 - 115)****11.4.2 Commissioning the Gas Valves (all gases)****11.4.2.1 Check Burner Gas Pressure**

1. Loosen the screw cover of the outlet (burner) pressure test point and connect a manometer.
2. With the burner firing, measure the pressure on the manometer. To adjust the burner pressure, remove the regulator cover from the valve and turn the regulator adjustment screw to set the required burner pressure as stated in the Technical Data Tables for the correct gas and model on Page 8, Section 4.4.

**NOTE:** If the correct burner pressure cannot be reached, then check the inlet pressure to the valve, with the burner firing. See Technical Data Tables on Page 8, Section 4.4 for inlet pressure requirement.

**Do not continue to adjust the regulator if the pressure is not changing.**

If the inlet pressure is too low to allow correct burner pressure setting, then the gas inlet pressure must be corrected before completing the commission.

**Check Gas Rate**

1. After burner pressure adjustment, allow the heater to operate for at least 15 minutes and then re-check settings.
2. Remove the manometer and refit all covers to the valve and tighten the screw of the outlet pressure tap.
3. Check gas flow rate at gas meter.

**11.5 Combustion Testing**

The only adjustment to alter combustion performance is burner pressure. Combustion quality must be tested to prove correct heater operation. Incorrect results will indicate faults with the installation or appliance.

Combustion testing must be carried out with all covers in place. The flue gas is sampled in the flue, within 1 meter of the heater. The values of CO<sub>2</sub> should be between 6.5% to 8.0% for natural gas and 7.0% to 9.1% for LPG dependant upon model.

The CO will be up to 80 ppm (0.008%) dry, air free dependant upon model. Temperature rise of the flue gases above ambient should be approximately 160° C to 180° C. Seal test hole in flue after testing.

**Pressure Switch:** The pressure switch is factory pre-set for each model and is not adjustable.

**11.6 Turning Off the Heater**

Set the external controls to the off position and the main burner will stop.

The fans will run until they are stopped automatically by the fan thermostat.

**Do not use electrical isolator for control of heater. Electrical isolator will switch off the fan. Heat exchanger could be damaged. Warranty will not cover damage to the heat exchanger if operated improperly.**



### **11.7 External Controls**

External controls may include time switch, room thermostat and frost thermostat. Operate each control to ensure that they function correctly. Set the time switch (if fitted) and room thermostat to the users' requirements.

### **11.8 Complete the Commissioning**

Ensure that all covers are fitted correctly and all test points are properly sealed.

### **11.9 Instruction to the User**

Explain the controls of the heater to the user including how to turn it on and off, using the controls fitted on site.

Give this manual to the user.

Ensure that the user is shown and understands the importance of maintaining clearances to combustibles and the user instructions *on Page 28, Section 12 through Page 29, Section 12.5* and all warnings defined in this manual.

**SECTION 12: USER INSTRUCTIONS**

**12.1 User Instructions**

The CTU heaters are fully automatic and operate from the external controls fitted on site.

The only user controls at the heater are the:

Burner Lockout Reset Button:

See Page 28, Section 12.3.2

Thermostat Limit Thermodisc Reset Button:

See Page 28, Section 12.3.1

**⚠ WARNING**

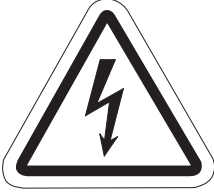

**Electrical Shock Hazard**

**Disconnect electrical power before servicing.**

**Failure to follow these instructions can result in death or electrical shock.**

**12.2 Heater Operation**

When the heater has been switched on by the remote controls installed on site, the main burner will automatically turn on.

The burner control box will control the safe ignition of the flame.

All heaters require a constant gas and electricity supply which must not be interrupted during the normal operation of this heater.

**Figure 13: Heater Operating Sequence**

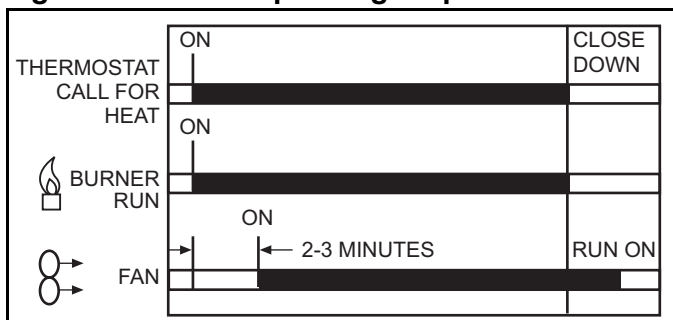

**12.3 Common User Controls**

**12.3.1 Thermostat Limit Thermodisc**

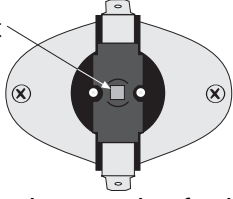

These are hand reset devices to give further protection against fan failure.

**NOTE:** To reset, the heat exchanger must be cool.

Description	Part Number
All Models	90412100

**⚠ WARNING**



**Explosion Hazard**

**If control locks out, do not make more than 3 attempts to restart the heater.**

**Dangerous gas mixtures can build up.**

**The fault must be traced and repaired by a registered installer or service engineer.**

**Failure to follow these instructions can result in death, injury or property damage.**

**12.3.2 Burner Lockout Reset Button**

The red warning light at the front of the heater will illuminate when the control has gone to lockout. This may be caused by flame failure. Press the reset button on the back of the heater, (See Page 5, Section 4.1), or the remote reset if installed on site.

**12.4 Lighting Instructions**

**12.4.1 To Turn On Heater**

1. Ensure that the electrical and gas supplies to the heater are on. Check that the on site controls are "ON".

**NOTE:** The thermostat setting must be above the ambient temperature for the heater to operate.

2. The green light will be on and the automatic firing sequence will begin as described on Page 25, Figure 10. The heater will now operate automatically under the control of the on site controls. Following long shut down periods, the control may go to lockout. See Page 28, Section 12.3.2.

### 12.4.2 To Turn the Heater Off

Set the installed remote controls to the "OFF" position.

The burner will turn off immediately.

The fan will continue to run for a few minutes.

To restart, turn the control used above to "ON".

### 12.5 Simple Fault Finding

Some possible reasons for the heater not operating are:

1. Gas supply not turned ON.
2. Electricity supply not turned ON.
3. The time and/or temperature controls are not "ON".
4. The thermostat limit thermodisc may have operated. This may be caused by an interruption of the electrical supply or failure of the distribution fan.

If the thermostat limit thermodisc persistently operates, there is a fault which must be investigated by a contractor qualified in the installation and service of gas-fired heating equipment.

#### 12.5.1 Simple Fault Finding (Burner Faults)

If the burner fails to ignite for any reason, it will go to lockout. This will be indicated by the red light on the heater or at the remote indicator (if fitted).

1. Press in and release the lockout reset button. If a remote reset is not fitted, a reset button is on the rear panel of the heater.

See Page 5, Section 4.1.

Lockout should not occur during normal operation of the heater and indicates there is a fault condition which must be corrected.

#### FOR YOUR SAFETY

*If you smell gas:*

1. Open windows.
2. DO NOT try to light any appliance.
3. DO NOT use electrical switches.
4. DO NOT use any telephone in your building.
5. Leave the building.
6. Immediately call your local gas supplier after leaving the building. Follow the gas supplier's instructions.
7. If you cannot reach your gas supplier, call the Fire Department.

#### WARNING



#### Fire Hazard

Do not store or use petrol or other flammable vapours and liquids in the vicinity of this or any other appliance.

Some objects will catch fire or explode when placed close to heater.

Failure to follow these instructions can result in death, injury or property damage.

## SECTION 13: SERVICING

### 13.1 Servicing Instructions

After commissioning, the heater will require maintenance to be carried out annually. If the heater is used in a dirty or dusty area, more frequent maintenance may be necessary.

Installation, service and annual inspection of heater must be done by a contractor qualified in the installation and service of gas-fired heating equipment.

<b>WARNING</b>
<b>Cut Hazard</b>
<p>Turn off gas and electrical supply before maintenance.</p> <p>Fan can start automatically at any time.</p> <p>Failure to follow these instructions can result in severe injury or product damage.</p>

**NOTE 1:** After any maintenance or repair work always test fire the heater in accordance with the commissioning instructions on *Page 24, Section 11 through Page 27, Section 11.9* to ensure all safety systems are in working order before leaving the heater to operate. Minor faults may be traced by using the troubleshooting charts on *Page 32, Section 15 through Page 34, Section 15.4*.

**NOTE 2:** Check all gas pipes and pipe joints to ensure there are no cracks or gas leaks. Any cracks in the pipes or pipe joints must be repaired.

**NOTE 3:** Inspect all suspended components and hardware. Insure that they are in good condition, properly tightened, and corrosion free.

### 13.2 Burner Maintenance

1. Open the hinged door and remove the burner compartment cover. See *Page 36, Section 16.2*.
2. Clean any deposits from the main burner which may have formed in the injectors or venturi of the burner. See *Page 36, Section 16.2*.
3. Remove the ignition electrode and flame probe. Check condition of ignition electrode and flame probe. Clean off any deposits which may have been formed, check condition of ceramic insulators. Replace as necessary.

### 13.3 Fan/Motor Assembly Maintenance

The main fan bearings are permanently sealed and do not need lubrication. Before cleaning, turn off gas and electrical supply. Remove the fan(s) and use a small brush or duster to clean the fan blades from each side. Replace fan(s) when done.

#### 13.3.1 For CTUB & CTUC Centrifugal Fan Models

CTUB and CTUC models are fitted with thermally protected three speed fans. The number of fans can be found on *Page 41, Section 16.9* and the standard air flow for each model can be found on *Page 7, Section 4.3*.

For CTUC models, the fans may be accessed via the removable panels in the top, bottom and sides of the inlet spigot compartment as required.

Do not operate at higher speeds than the original setting on the heater without prior consultation with Roberts-Gordon.

The "HIGH" speed option is available to give the normal required air flow against higher static pressures and is not intended to be operated free blowing or against low resistance. Use of the fans under these conditions may cause the fan thermal overload to operate and the fan thermostat to cycle. All fans on a heater must be set to operate at the same speed. For Models 50 - 115, they will be switched using a fan relay built into the heater. See *Page 40, Section 16.8.2*.

### 13.4 Heat Exchanger Maintenance

The heat exchanger will remain clean unless a problem has developed with combustion. Inspect the heat exchanger. Look for signs of overheating at the front tubes which may indicate burner over firing or persistently low air flows.

### 13.5 Gas Control Valve Maintenance

No regular maintenance is required on these devices. To change gas control valves, See *Page 35, Step 16.1 and Page 39, Section 16.5*.

**Do not repair or disassemble on site.**

**Replace faulty gas valves with genuine ROBERTS GORDON® replacement parts.**

### 13.6 Flue Fan

The flue fan should not require maintenance. However, if the air pressure switch is causing burner lockout, then remove the flue fan from the vent box by unscrewing the screw at the outlet flange and the flue fan mounting plate (See *Page 38, Section 16.4*). Ensure that the fan is free to run and that the fan wheel is clean.

## SECTION 14: CONVERSION BETWEEN GASES

### 14.1 General

Conversion between gasses will require a change of burner injectors and the gas valve re-commissioning to the new conditions.

### 14.2 Burner Conversion

Conversion of the burner assembly from one gas to the other is the same for all types of heaters.

1. Remove the burner compartment cover as shown on *Page 36, Section 16.2*.
2. Remove the connection between the gas valve outlet and the manifold. See *Page 35, Section 16.1* for gas valve removal.
3. Remove the manifold from the burner assembly by removing the screws at the top and bottom. See *Page 36, Section 16.2.1*.
4. Remove the main burner injectors.
5. Replace with the injectors for the new gas ensuring a gas tight seal.
6. Refit all components in reverse order.

### 14.3 Gas Valves

All gas valves used on the CTU have pressure regulators that may be set to operate on natural gas or LPG.

Conversion is carried out by re-setting the burner pressure to the value in the data table during commissioning. See *Page 8, Section 4.4*.

Ensure that the gas inlet pressure to the heater is correct for the new gas, and that the gas supply has been purged of the old gas.

**SECTION 15: TROUBLESHOOTING**

**15.1 General**

⚠ WARNING





Explosion Hazard

**Installation must be done by a registered installer/contractor qualified in the installation and service of gas-fired heating equipment or your gas supplier.**

**Failure to follow these instructions can result in death, injury or property damage.**

**Installation Code and Annual Inspections:** All installations and service of ROBERTS GORDON® equipment must be performed by a contractor qualified in the installation and service of equipment sold and supplied by Roberts-Gordon and conform to all requirements set forth in the ROBERTS GORDON® manuals and all applicable governmental authorities pertaining to the installation, service and operation of the equipment.

To help facilitate optimum performance and safety, Roberts-Gordon recommends that a qualified contractor annually inspect your ROBERTS GORDON® equipment and perform service where necessary, using only replacement parts sold and supplied by Roberts-Gordon.

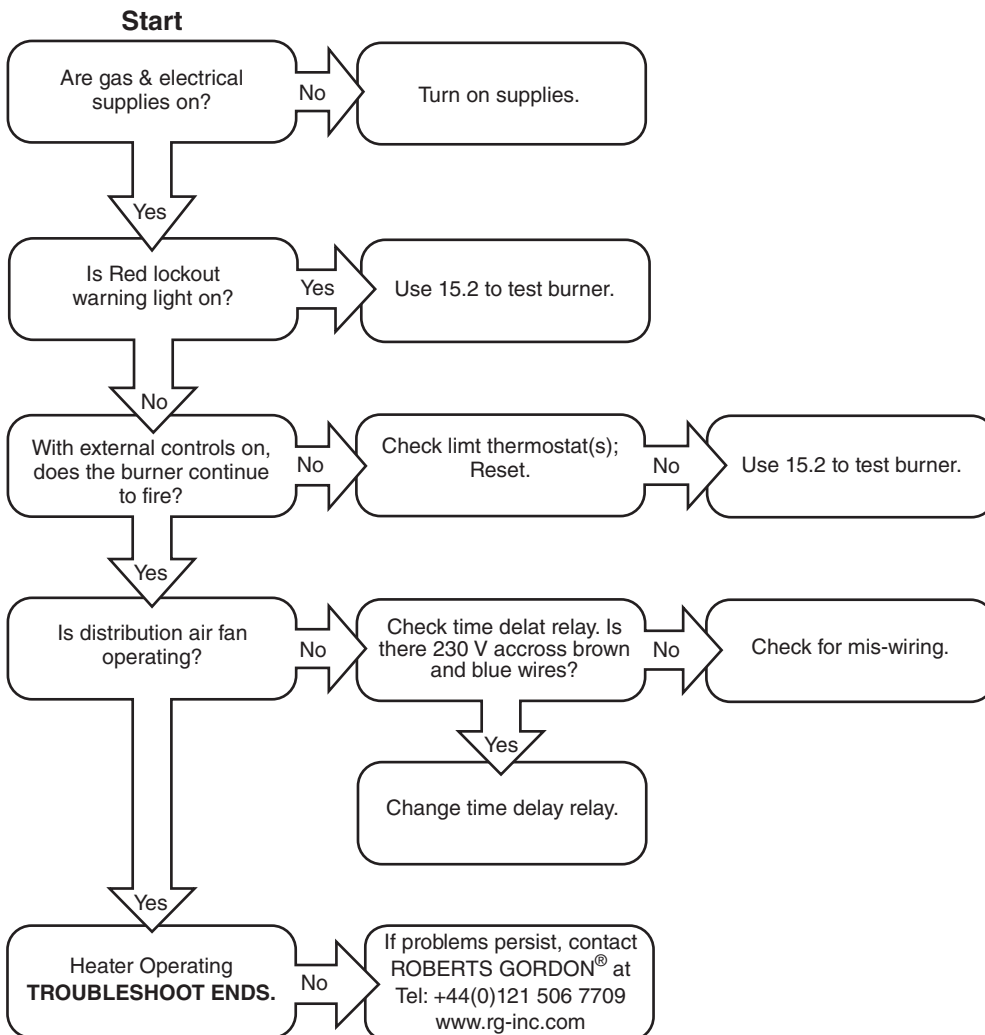

For your safety and optimum heater performance, use only ROBERTS GORDON® replacement parts. **Conduct Commissioning procedure as shown on Page 24, Section 11.**

## 15.2 Troubleshooting For Automatic Ignition Burner Systems

There are two burner controls used: Honeywell S4563C and S4565C. They both have similar operating sequences. To measure flame current, connect a 0 - 50  $\mu$ A DC meter in series with the flame probe. If the meter reads negative values, then reverse the test leads.

### ⚠ WARNING



#### Electrical Shock Hazard

Do not touch ignition components.

Voltage from ignition components is high.

Failure to follow these instructions can result in death or electrical shock.

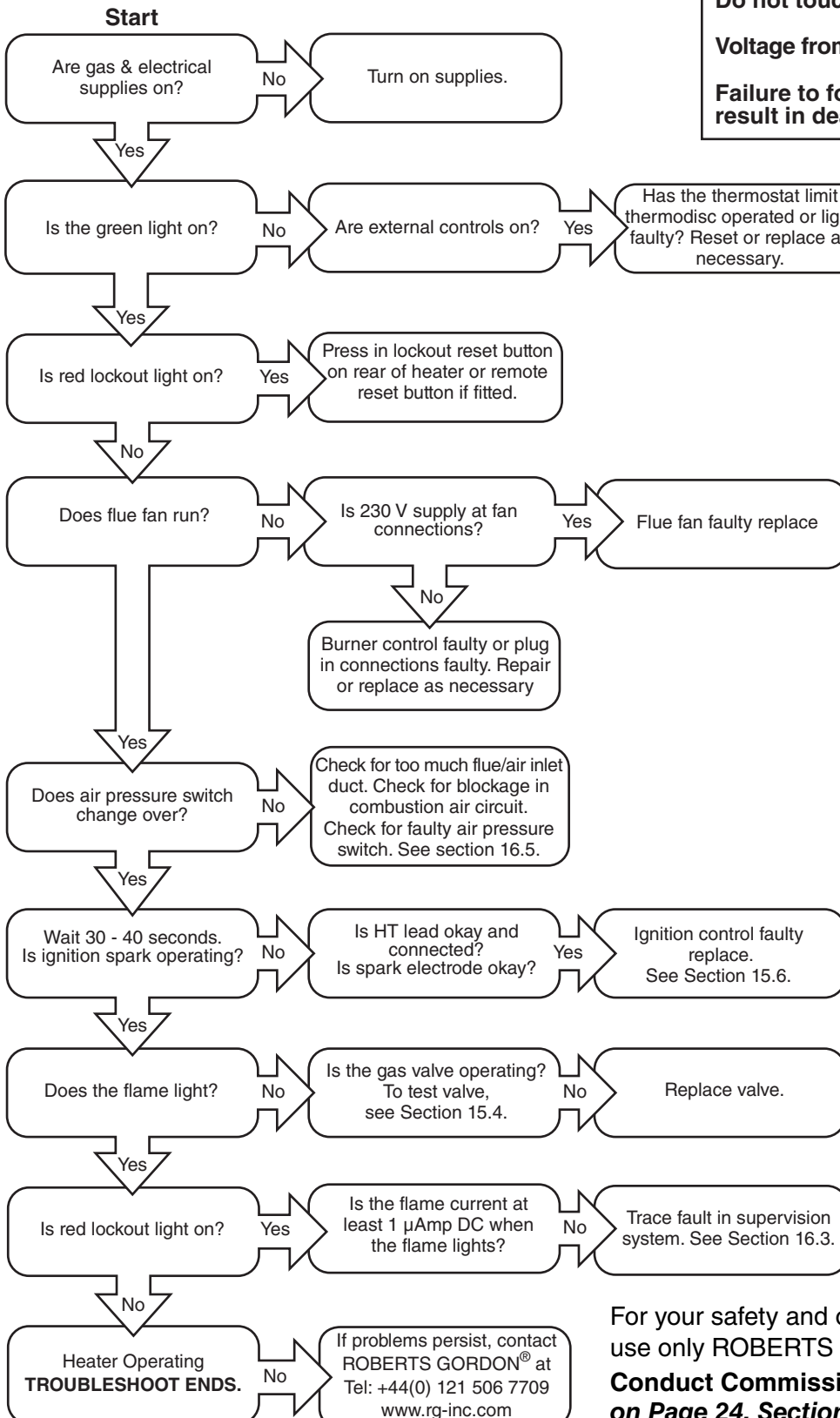

For your safety and optimum heater performance, use only ROBERTS GORDON® replacement parts. **Conduct Commissioning procedure as shown on Page 24, Section 11.**

### 15.3 Troubleshooting for Flame Supervision System

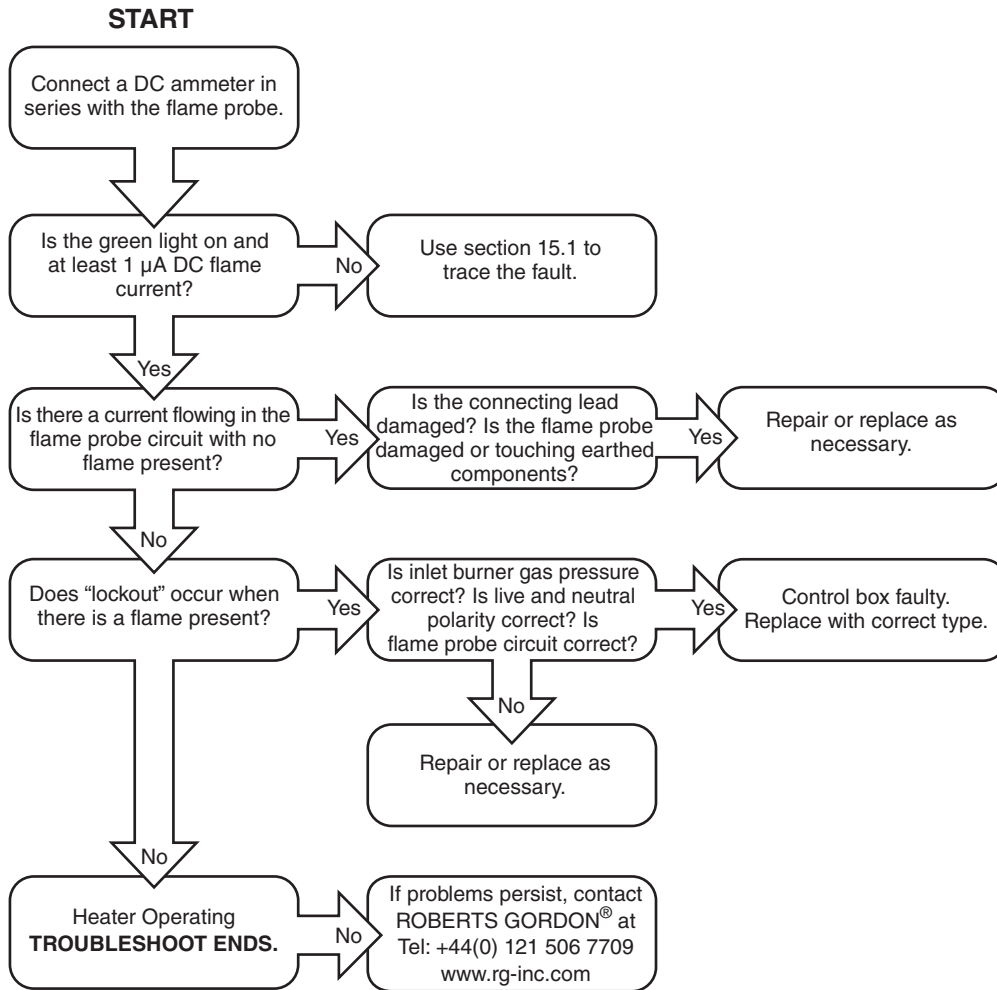

**NOTE:** Minimum flame probe current 1 µA DC. Typical flame probe current 3-5 µA DC.

### 15.4 Troubleshooting for Solenoid Valves

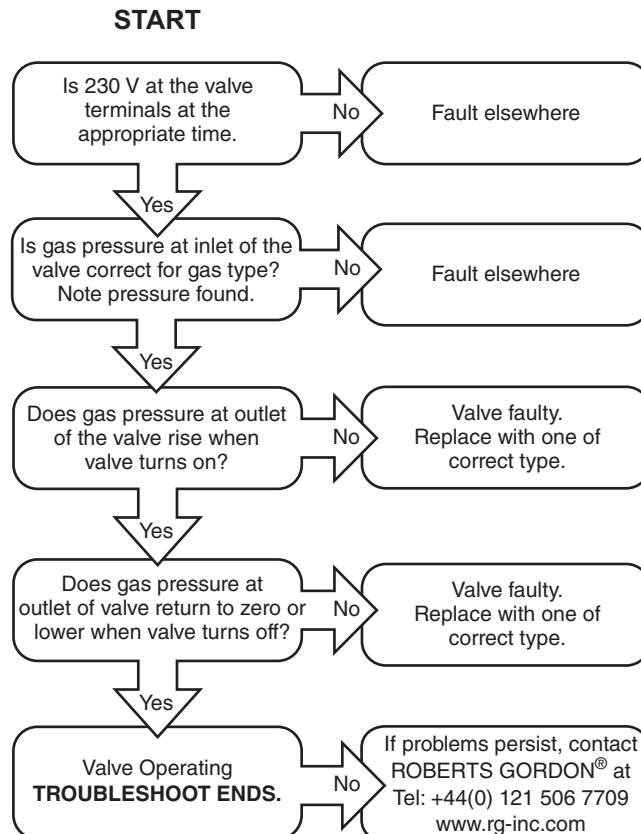



**SECTION 16: REMOVAL AND REPLACEMENT PARTS**

See warnings and notes on *Page 30, Section 13* before removing or replacing parts.

**Burner Components**

All serviceable burner parts are accessed by the door on the right side of the heater. Use a screwdriver to turn the latch 90°. See *Page 5, Section 4*.

**16.1 Gas Valve**

Remove the gas supply pipe at the heater inlet.

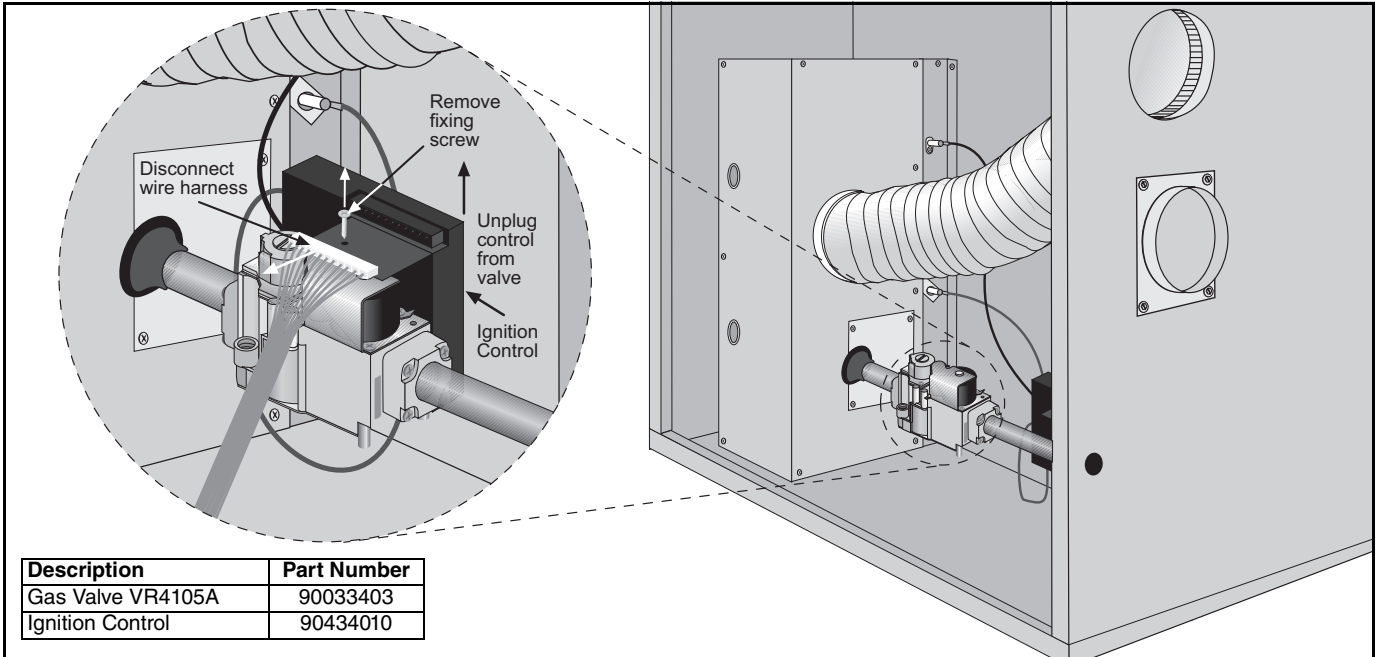
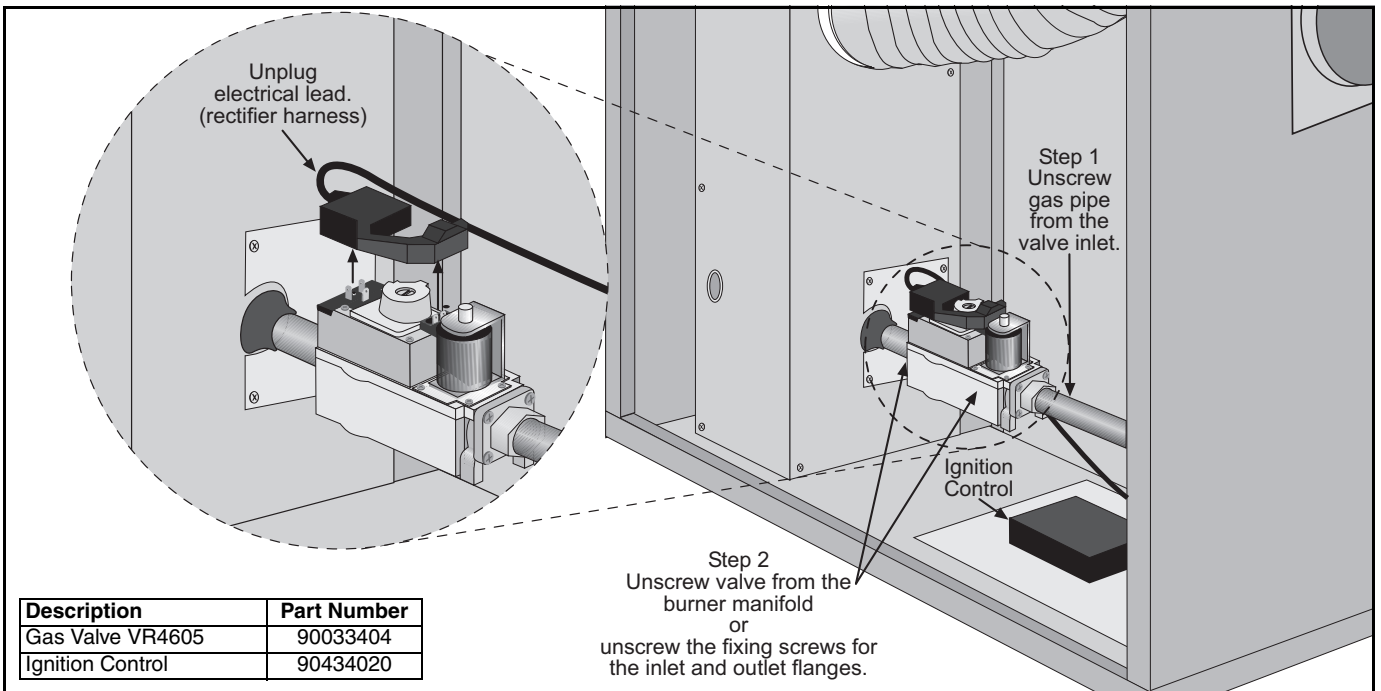
**16.1.1 Models 22 - 60****16.1.2 Models 75 - 115****16.1.3 All Models**

Replace in reverse order. Verify that the gas flow direction of the valve is correct. Use a minimum amount of gas seal on the thread joint. Re-use the "O" ring seal in the outlet flange where fitted. Check that all the joints are leak free. Reset gas valve. See

*Page 26, Section 11.4.2.*

**IT IS IMPORTANT THAT ONLY THE CORRECT GAS VALVES SPECIFIED FOR EACH MODEL TYPE ARE USED WHEN REPLACING THESE CONTROLS.**

## 16.2 Burner Compartment

The burner compartment is a sealed compartment. Following any work, re-seal the compartment with the gas pipe rubber seal fully in place and all screws fitted and tight.

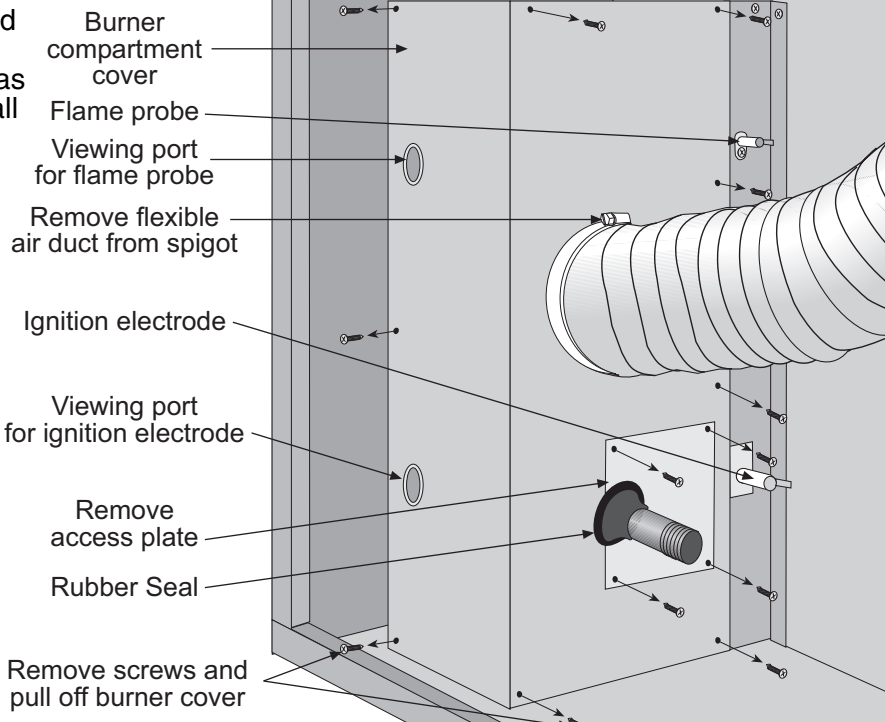

### 16.2.1 Burner Injectors

Ensure gas tight fitting of injectors.  
 Ensure correct alignment with burners.  
 Ensure all pipe joints are gas tight.

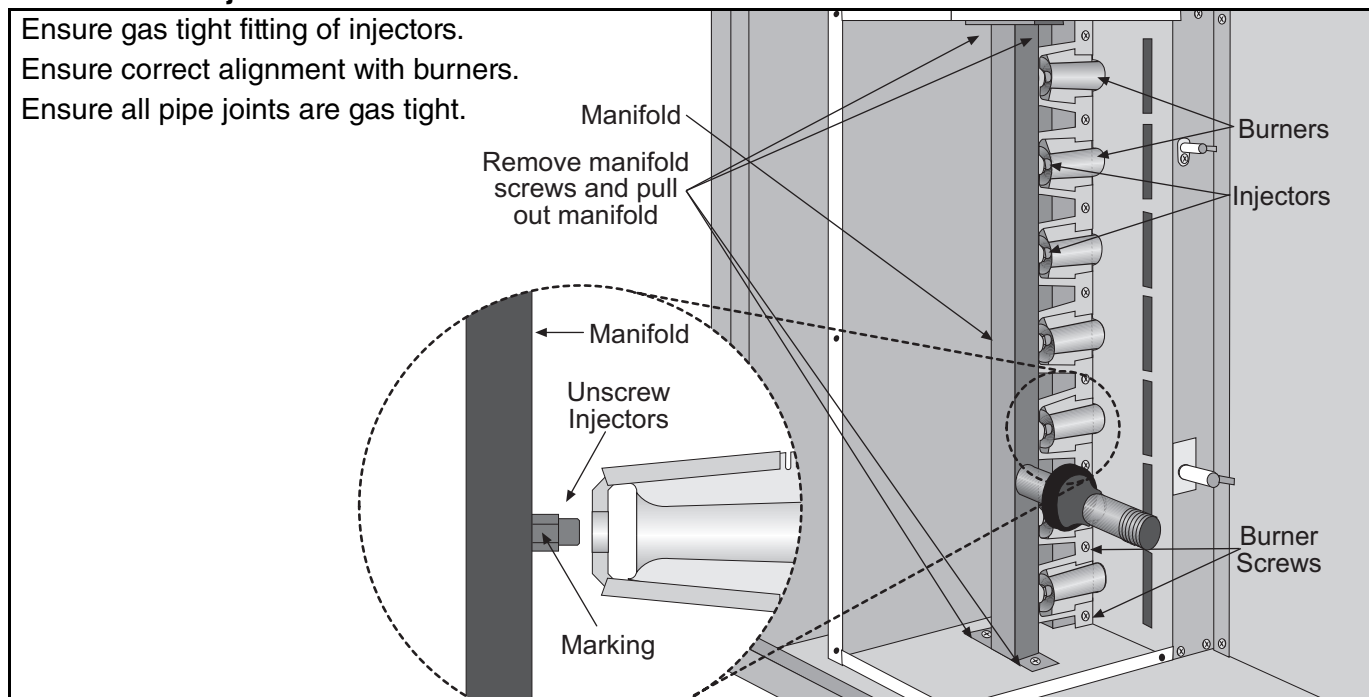

	CTU-22	CTU-30	CTU-35	CTU-40	CTU-50	CTU-60	CTU-75	CTU-90	CTU-100	CTU-115
Injector Quantity	5	5	6	7	9	11	12	14	15	17
<b>Natural Gas (G20) and (G25)</b>										
Injector size mm Ø	2.08	2.25	2.25	2.25	2.25	2.25	2.71	2.71	2.71	2.71
in Ø	0.0819	0.0886	0.0886	0.0886	0.0886	0.0886	0.1067	0.1067	0.1067	0.1067
Marking	45	225	225	225	225	225	36	36	36	36
RG P/N	91930045	91930225	91930225	91930225	91930225	91930225	91930036	91930036	91930036	91930036
<b>LPG Gas Propane (G31) and LPG Gas Butane (G30)</b>										
Injector size mm Ø	1.25	1.40	1.40	1.40	1.40	1.35	1.51	1.51	1.51	1.51
in Ø	0.0492	0.0551	0.0551	0.0551	0.0551	0.0531	0.0594	0.0594	0.0594	0.0594
Marking	125	54	54	54	54	135	53	53	53	53
RG P/N	91930125	91930054	91930054	91930054	91930054	91930135	91930053	91930053	91930053	91930053

## 16.3 Ignition Electrode and Flame Probe

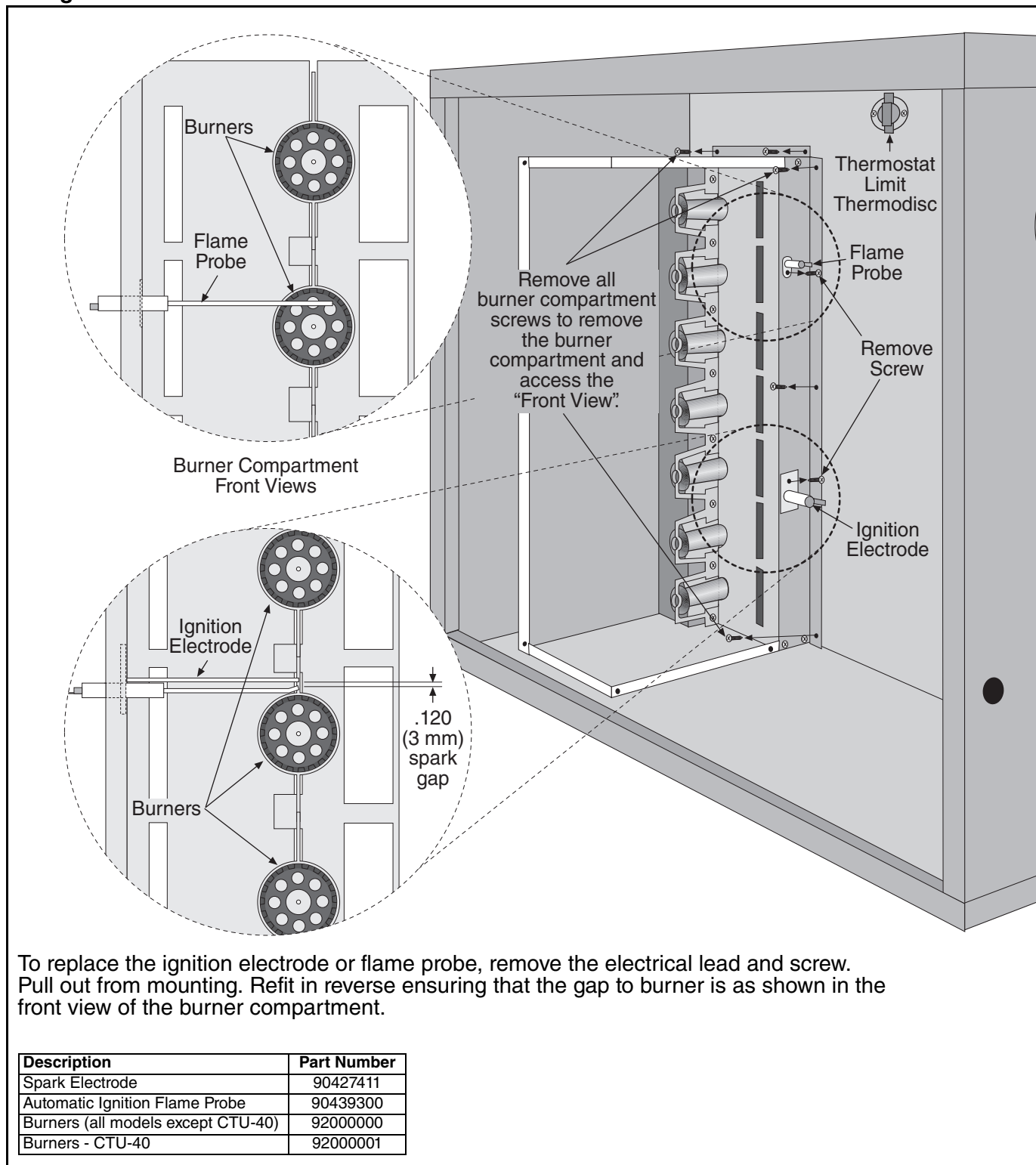

16.4 Flue Fan

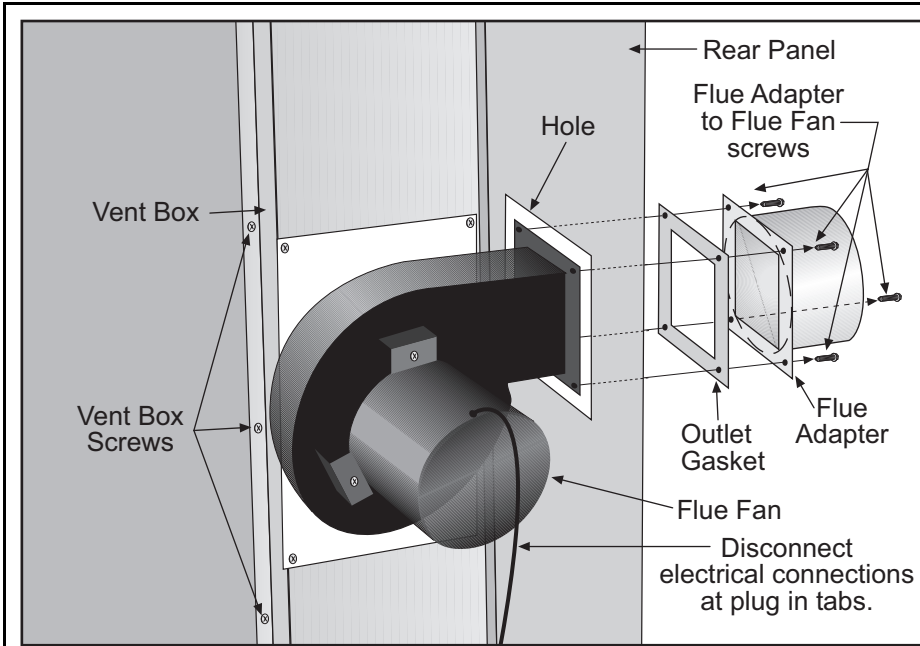

Remove screws securing outlet flange to the flue adapter.

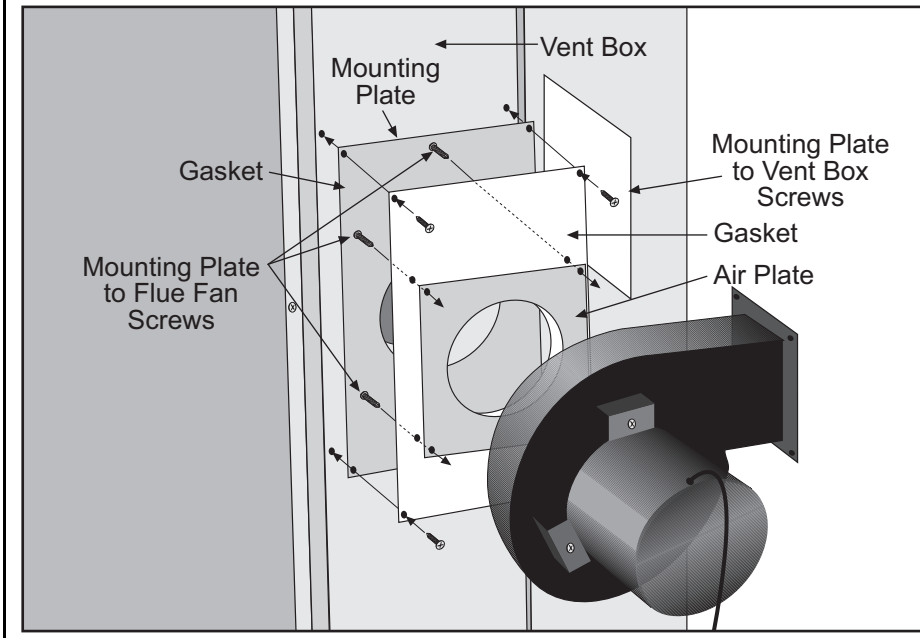

Remove screws securing flue fan mounting plate to vent box. Remove screws securing mounting plate to fan. Refit in reverse. Use new gaskets. Ensure sealed joints. Ensure mounting plate orifice is clear and not obstructed.

	CTU-22	CTU-30	CTU-35	CTU-40	CTU-50	CTU-60	CTU-75	CTU-90	CTU-100	CTU-115
Flue Fan	Torin DSA 508-128 077272	Torin DSA 508-128 077272	Torin DSA 508-128 077272	Torin DSA 508-128 077272	Torin DSA 524-202 077273	Torin DSA 524-202 077273	AO Smith JFIG098NS	AO Smith JFIG098NS	AO Smith JFIG098NS	Torin DSF 146-052 077274
RG P/N	90710430	90710430	90710430	90710430	90710440	90710440	90710001	90710001	90710001	90710450
Air mm Ø Plate in Ø	47.6 1.875	53.1 2.09	60.7 2.39	69.1 2.72	60.7 2.39	69.9 2.75	97.0 3.82	103.6 4.08	110.5 4.35	152.4 6
RG P/N	11011139	11011138	11011140	11011137	11011136	11011135	11011134	11011133	11011132	11011131

**IT IS IMPORTANT THAT ONLY THE CORRECT FLUE FAN SPECIFIED FOR EACH MODEL TYPE IS USED WHEN REPLACING THESE ITEMS.**

Carry out a commission after working on or changing a flue fan. See Page 28, Section 12.

## 16.5 Pressure Switch

Pull off 3 way connector. Spring open plastic clips of mounting cradle. Replace with correct type of pressure switch for model. The pressure switches are colour coded for each pressure setting.

<b>⚠ WARNING</b>

<p><b>Carbon Monoxide Hazard</b></p> <p><b>Use correct pressure switch specified for each model.</b></p> <p><b>Use of incorrect pressure switch could cause unsafe condition.</b></p> <p><b>Failure to follow these instructions can result in death or serious injury.</b></p>

Carry out a commission after working on or changing a pressure switch. See *Page 24, Section 11*.

	CTU-22	CTU-30	CTU-35	CTU-40	CTU-50	CTU-60	CTU-75	CTU-90	CTU-100	CTU-115
RG P/N	90439801	90439810	90439804	90439803	90439810	90439802	90439811	90439807	90439811	90439807
Colour Code	pink	grey	white	grey	grey	yellow	grey	brown	grey	brown
Set Point mbar	0.57	0.92	1.17	1.02	0.87	0.80	1.79	1.69	1.79	1.69
in wc	0.23	0.37	0.47	0.41	0.35	0.32	0.72	0.68	0.72	0.68

## 16.6 Ignition Control

**IT IS IMPORTANT THAT ONLY THE CORRECT IGNITION CONTROL SPECIFIED FOR EACH MODEL TYPE IS USED WHEN REPLACING THESE ITEMS.**

### 16.6.1 S4565C Models 22 to 60

This control plugs onto the gas valve. Pull out 12 pin electrical connection. Pull out ignition cable and flame probe cable noting their positions

Release screw securing control to gas valve  
Refit in reverse. Ensure correct location of ignition and flame probe cables. Ensure that the earth connection is made directly to the earth point on the gas valve.

### 16.6.2 S4563C Models 75 to 115

This control is mounted at the electrical mounting plate. Pull out the 3 cable connectors.  
Pull out ignition cable, ignition earth and flame probe cable noting their positions. Remove the screws.  
Refit in reverse. Ensure correct location of ignition and flame probe cables.

## 16.7 CTUA Axial Fan/Guard/Motor Assembly

The axial fan unit for the CTUA heater is supplied completely assembled and balanced.

### 16.7.1 Fan Removal and Replacement

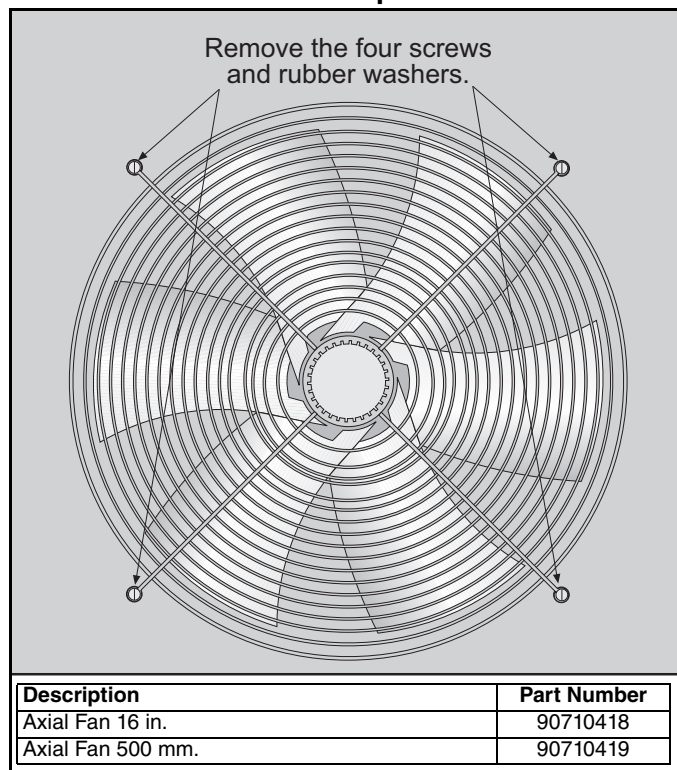

- Check that the fan blades are free to rotate before turning on the power to the fan.
- Strictly comply with the colour code of the fan wires to ensure correct operation. See Page 16, Section 10.3 through Page 17, Section 10.4 wiring diagrams
- Use only genuine ROBERTS GORDON® replacement parts.

## 16.8 CTUB & CTUC Centrifugal Fan/Guard/Motor Assembly

The direct drive fan/s for the CTUB & CTUC range is supplied as a complete assembly. Take careful note of the electrical connections of the fan before disconnecting from the terminals.

For the CTUC versions fitted with an inlet spigot assembly, the fans may be accessed through the removable covers on the sides, top and bottom of the spigot, as required.

### 16.8.1 Fan Removal and Replacement

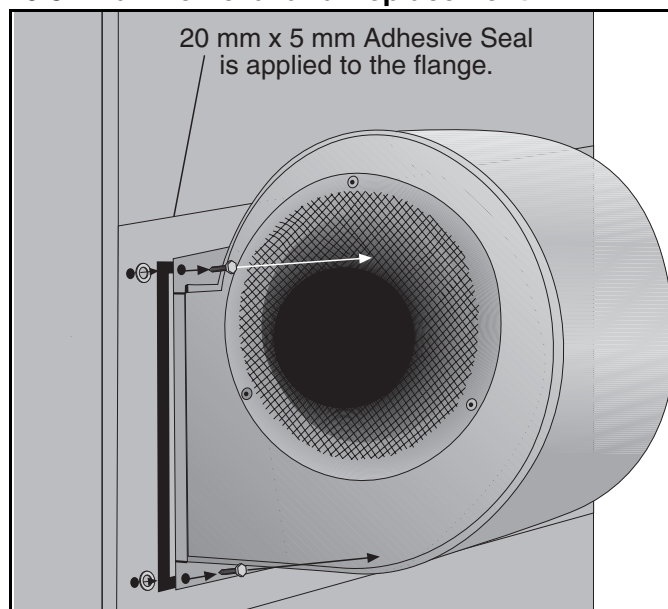

Description	Part Number
Torin Fan DDC 270-270	A047
Torin Fan DDC 241-241	A049

Remove the fan by removing the fixing screws while supporting the weight of the fan (approx. 19 kg).

### 16.8.2 To Replace the Fan(s)

To reassemble, reverse the procedure shown above.

- Fit new rubber seal between the fan flange and the heater rear panel.
- Fit to the rear panel in the correct orientation as shown on Page 41, Figure 14.
- Strictly comply with the colour code of the fan wires to ensure correct operation. See Page 18, Section 10.5 through Page 20, Section 10.7 wiring diagrams.



- Use only genuine ROBERTS GORDON® replacement parts.

The three speed winding connections are:

**Low speed:** White N, Red Live The other two windings are "parked" separately in spare terminals.

**Medium speed:** White N, Blue live. The other two windings are "parked" separately in spare terminals.

**High speed:** White N, Black live. The other two windings are "parked" separately in spare terminals.

- Check that the fan blades are free to rotate without catching before turning on the power to the fan.

- Set all fans to operate at the same speed.

**Figure 14: Centrifugal Fan Orientation**

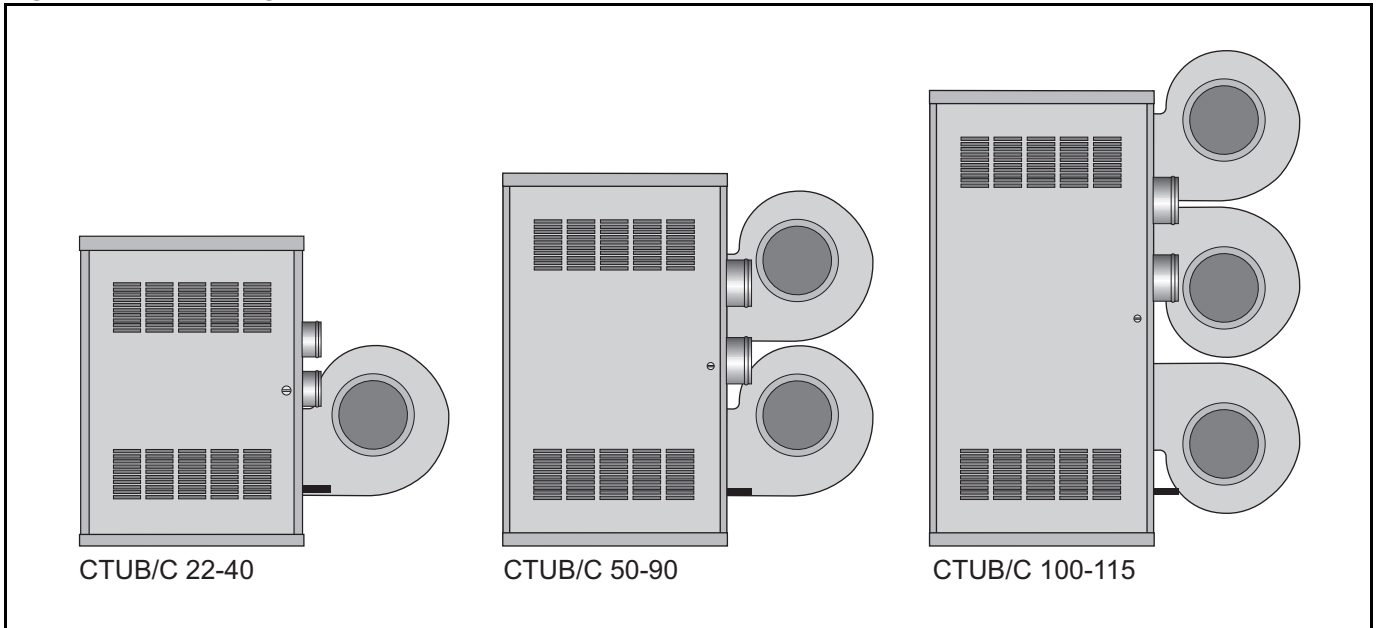

## 16.9 Fan Data

	CTU-22	CTU-30	CTU-40	CTU-50	CTU-60	CTU-75	CTU-90	CTU-100	CTU-115
Axial Fan Type CTUA Models	EBM S4E420 AA06-02	EBM S4E420 AA06-02	EBM S4E420 AA06-02	Ma-Vib V02-C100	Ma-Vib V02-C100	EBM S4E420 AA06-02	EBM S4E420 AA06-02	Ma-Vib V02-C100	Ma-Vib V02-C100
RG P/N	90710418	90710418	90710418	90710419	90710419	90710418	90710418	90710419	90710419
Quantity	1	1	1	1	1	2	2	2	2
Fan Rating (Watts per Fan)	160	160	160	370	370	160	160	370	370
Centrifugal Fan Type CTUB/C Models	Torin 241-241	Torin 241-241	Torin 241-241	Torin 241-241	Torin 241-241	Torin 270-270	Torin 270-270	Torin 270-270	Torin 270-270
RG P/N	A049	A049	A049	A049	A049	A047	A047	A047	A047
Quantity	1	1	1	2	2	2	2	3	3
Normal Fan Rating (W)	1100	1100	1100	1100	1100	1200	1200	1200	1200
High Fan Rating (W)	1400	1400	1400	1400	1400	1700	1700	1700	1700









Attach this information to the wall near the ROBERTS GORDON® heater



Read the Installation, Commissioning, Operation and Service Manual thoroughly before installation, operation or service.

#### OPERATING INSTRUCTIONS

1. STOP! Read all safety instructions on this information sheet.
  2. Open the manual gas valve in the heater supply line.
  3. Turn on electric power to the heater.
  4. Set the thermostat to desired setting (above ambient temperature).  
The automatic starting sequence begins.
- NOTE:** Following long shutdown periods, the burner control may go to 'LOCKOUT' during the start sequence. Push the reset button to recommence firing. Contact service department if 'LOCKOUT' continues (see manual for details).

#### TO TURN OFF THE HEATER

1. Turn the thermostat/time switch to 'OFF'. The burner will turn 'OFF' immediately, but fans will continue to cool heat exchanger until the fan thermostat switches off.

#### IF THE HEATER WILL NOT OPERATE, TO ENSURE YOUR SAFETY, FOLLOW THESE INSTRUCTIONS TO SHUT DOWN YOUR HEATER

1. Set the thermostat to off or the lowest setting.
2. Turn off electric power to the heater.
3. Turn off the manual gas valve in the heater supply line.
4. Call your registered installer/contractor qualified in the installation and service of gas-fired heating equipment.

#### ⚠ WARNING



#### Fire Hazard

Some objects can catch fire or explode when placed close to heater.

Keep all flammable objects, liquids and vapors the required clearances to combustibles away from heater.

Failure to follow these instructions can result in death, injury or property damage.

#### Installation Clearances

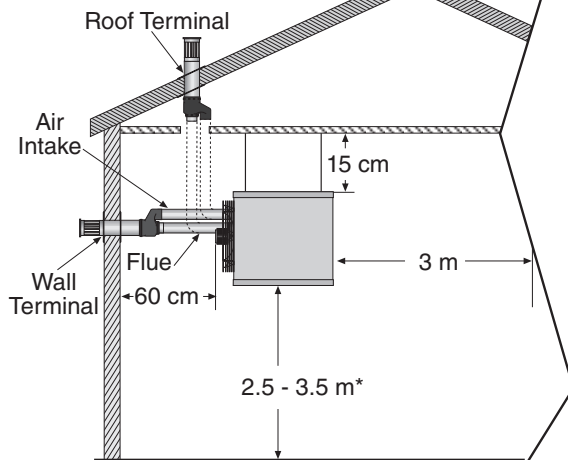

\*Heaters may be mounted at a higher level if destratification fans and/or turn down nozzles are installed.

#### Clearances to Combustibles

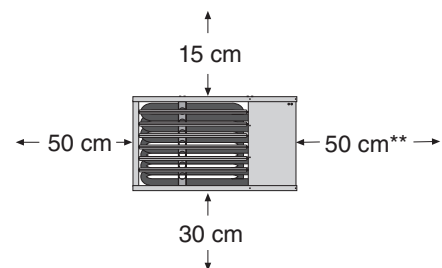

\*\*80 cm is necessary to service heater.

**Roberts-Gordon Europe Limited**  
Unit A, Kings Hill Business Park  
Darlston Road, Wednesbury  
West Midlands WS10 7SH UK  
Telephone: +44(0)121 506 7700

Fax: +44(0)121 506 7701  
Service Telephone: +44(0)121 506 7709  
Service Fax: +44(0)121 506 7702  
E-mail: uksales@rg-inc.com  
E-mail: export@rg-inc.com

**Roberts-Gordon, LLC**  
1250 William Street  
P.O. Box 44  
Buffalo, NY 14240-0044 USA

Telephone: 716.852.4400  
Fax: 716.852.0854  
Toll Free: 800.828.7450

#### Installation Code and Annual Inspections:

All installations and service of ROBERTS GORDON® equipment must be performed by a contractor qualified in the installation and service of equipment sold and supplied by Roberts-Gordon and conform to all requirements set forth in the ROBERTS GORDON® manuals and all applicable governmental authorities pertaining to the installation, service and operation of the equipment. To help facilitate optimum performance and safety, Roberts-Gordon recommends that a qualified contractor annually inspect your ROBERTS GORDON® equipment and perform service where necessary, using only replacement parts sold and supplied by Roberts-Gordon.

For installations at elevations above 2000' (610 m), the appliance shall be derated 4% for each 1000' (305 m) of elevation above sea level.

**Further Information:** Applications, engineering and detailed guidance on systems design, installation and equipment performance is available through ROBERTS GORDON® representatives. Please contact us for any further information you may require, including the Installation, Commissioning, Operation and Service Manual.

**These products are not for residential use.**

## Free Manuals Download Website

<http://myh66.com>

<http://usermanuals.us>

<http://www.somanuals.com>

<http://www.4manuals.cc>

<http://www.manual-lib.com>

<http://www.404manual.com>

<http://www.luxmanual.com>

<http://aubethermostatmanual.com>

Golf course search by state

<http://golfingnear.com>

Email search by domain

<http://emailbydomain.com>

Auto manuals search

<http://auto.somanuals.com>

TV manuals search

<http://tv.somanuals.com>