

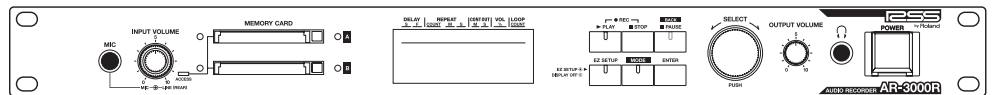

AUDIO RECORDER **AR-3000R**

OWNER'S MANUAL

Before using this unit, carefully read the sections entitled: "USING THE UNIT SAFELY" and "IMPORTANT NOTES" (p. 3; p. 5). These sections provide important information concerning the proper operation of the unit. Additionally, in order to feel assured that you have gained a good grasp of every feature provided by your new unit, OWNER'S MANUAL should be read in its entirety. The manual should be saved and kept on hand as a convenient reference.





- * CompactFlash and  are trademarks of SanDisk Corporation and licensed by CompactFlash association.
- * Roland Corporation is an authorized licensee of the CompactFlash™ and CF logo () trademarks.
- * MMP (Moore Microprocessor Portfolio) refers to a patent portfolio concerned with microprocessor architecture, which was developed by Technology Properties Limited (TPL). Roland has licensed this technology from the TPL Group.

Copyright © 2006 ROLAND CORPORATION

All rights reserved. No part of this publication may be reproduced in any form without the written permission of ROLAND CORPORATION.

WARNING: To reduce the risk of fire or electric shock, do not expose this apparatus to rain or moisture.

 ATTENTION: RISQUE DE CHOC ELECTRIQUE NE PAS OUVRIR	CAUTION RISK OF ELECTRIC SHOCK DO NOT OPEN	
CAUTION: TO REDUCE THE RISK OF ELECTRIC SHOCK, DO NOT REMOVE COVER (OR BACK). NO USER-SERVICEABLE PARTS INSIDE. REFER SERVICING TO QUALIFIED SERVICE PERSONNEL.		



The lightning flash with arrowhead symbol, within an equilateral triangle, is intended to alert the user to the presence of uninsulated "dangerous voltage" within the product's enclosure that may be of sufficient magnitude to constitute a risk of electric shock to persons.



The exclamation point within an equilateral triangle is intended to alert the user to the presence of important operating and maintenance (servicing) instructions in the literature accompanying the product.

INSTRUCTIONS PERTAINING TO A RISK OF FIRE, ELECTRIC SHOCK, OR INJURY TO PERSONS.

IMPORTANT SAFETY INSTRUCTIONS SAVE THESE INSTRUCTIONS

WARNING - When using electric products, basic precautions should always be followed, including the following:

1. Read these instructions.
2. Keep these instructions.
3. Heed all warnings.
4. Follow all instructions.
5. Do not use this apparatus near water.
6. Clean only with a dry cloth.
7. Do not block any of the ventilation openings. Install in accordance with the manufacturers instructions.
8. Do not install near any heat sources such as radiators, heat registers, stoves, or other apparatus (including amplifiers) that produce heat.
9. Do not defeat the safety purpose of the polarized or grounding-type plug. A polarized plug has two blades with one wider than the other. A grounding type plug has two blades and a third grounding prong. The wide blade or the third prong are provided for your safety. If the provided plug does not fit into your outlet, consult an electrician for replacement of the obsolete outlet.
10. Protect the power cord from being walked on or pinched particularly at plugs, convenience receptacles, and the point where they exit from the apparatus.
11. Only use attachments/accessories specified by the manufacturer.
12. Unplug this apparatus during lightning storms or when unused for long periods of time.
13. Refer all servicing to qualified service personnel. Servicing is required when the apparatus has been damaged in any way, such as power-supply cord or plug is damaged, liquid has been spilled or objects have fallen into the apparatus, the apparatus has been exposed to rain or moisture, does not operate normally, or has been dropped.

For the U.K.

IMPORTANT: THE WIRES IN THIS MAINS LEAD ARE COLOURED IN ACCORDANCE WITH THE FOLLOWING CODE.

BLUE: NEUTRAL
BROWN: LIVE

As the colours of the wires in the mains lead of this apparatus may not correspond with the coloured markings identifying the terminals in your plug, proceed as follows:
The wire which is coloured BLUE must be connected to the terminal which is marked with the letter N or coloured BLACK.
The wire which is coloured BROWN must be connected to the terminal which is marked with the letter L or coloured RED.
Under no circumstances must either of the above wires be connected to the earth terminal of a three pin plug.

For the USA

DECLARATION OF CONFORMITY Compliance Information Statement

Model Name : AR-3000R
Type of Equipment : Audio Recorder
Responsible Party : Roland Systems Group U.S.
Address : 425 Sequoia Drive Suite 114, Bellingham, Washington, 98226 USA
Telephone : 360-594-4282

USING THE UNIT SAFELY

INSTRUCTIONS FOR THE PREVENTION OF FIRE, ELECTRIC SHOCK, OR INJURY TO PERSONS

About ⚠ WARNING and ⚠ CAUTION Notices

⚠ WARNING	Used for instructions intended to alert the user to the risk of death or severe injury should the unit be used improperly.
⚠ CAUTION	Used for instructions intended to alert the user to the risk of injury or material damage should the unit be used improperly. * Material damage refers to damage or other adverse effects caused with respect to the home and all its furnishings, as well to domestic animals or pets.

About the Symbols

	The ⚠ symbol alerts the user to important instructions or warnings. The specific meaning of the symbol is determined by the design contained within the triangle. In the case of the symbol at left, it is used for general cautions, warnings, or alerts to danger.
	The ⚡ symbol alerts the user to items that must never be carried out (are forbidden). The specific thing that must not be done is indicated by the design contained within the circle. In the case of the symbol at left, it means that the unit must never be disassembled.
	The ⚡ symbol alerts the user to things that must be carried out. The specific thing that must be done is indicated by the design contained within the circle. In the case of the symbol at left, it means that the power-cord plug must be unplugged from the outlet.

ALWAYS OBSERVE THE FOLLOWING

⚠ WARNING

- Before using this unit, make sure to read the instructions below, and the Owner's Manual.

- Do not open or perform any internal modifications on the unit. (The only exception would be where this manual provides specific instructions which should be followed in order to put in place user-installable options; see p. 15.)

- Do not attempt to repair the unit, or replace parts within it (except when this manual provides specific instructions directing you to do so). Refer all servicing to your retailer, the nearest Roland Service Center, or an authorized Roland distributor, as listed on the "Information" page.

- Never use or store the unit in places that are:
 - Subject to temperature extremes (e.g., direct sunlight in an enclosed vehicle, near a heating duct, on top of heat-generating equipment); or are
 - Damp (e.g., baths, washrooms, on wet floors); or are
 - Humid; or are
 - Exposed to rain; or are
 - Dusty; or are
 - Subject to high levels of vibration.

- This unit should be used only with a rack or stand that is recommended by Roland.

⚠ WARNING

- When using the unit with a rack or stand recommended by Roland, the rack or stand must be carefully placed so it is level and sure to remain stable. If not using a rack or stand, you still need to make sure that any location you choose for placing the unit provides a level surface that will properly support the unit, and keep it from wobbling.

- The unit should be connected to a power supply only of the type described in the operating instructions, or as marked on the side of unit.

- Use only the attached power-supply cord. Also, the supplied power cord must not be used with any other device.

- Do not excessively twist or bend the power cord, nor place heavy objects on it. Doing so can damage the cord, producing severed elements and short circuits. Damaged cords are fire and shock hazards!

- This unit, either alone or in combination with an amplifier and headphones or speakers, may be capable of producing sound levels that could cause permanent hearing loss. Do not operate for a long period of time at a high volume level, or at a level that is uncomfortable. If you experience any hearing loss or ringing in the ears, you should immediately stop using the unit, and consult an audiologist.

- Do not allow any objects (e.g., flammable material, coins, pins); or liquids of any kind (water, soft drinks, etc.) to penetrate the unit.

⚠ WARNING

- Immediately turn the power off, remove the power cord from the outlet, and request servicing by your retailer, the nearest Roland Service Center, or an authorized Roland distributor, as listed on the "Information" page when:
 - The power-supply cord, or the plug has been damaged; or
 - If smoke or unusual odor occurs
 - Objects have fallen into, or liquid has been spilled onto the unit; or
 - The unit has been exposed to rain (or otherwise has become wet); or
 - The unit does not appear to operate normally or exhibits a marked change in performance.
- In households with small children, an adult should provide supervision until the child is capable of following all the rules essential for the safe operation of the unit.
- Protect the unit from strong impact. (Do not drop it!)
- Do not force the unit's power-supply cord to share an outlet with an unreasonable number of other devices. Be especially careful when using extension cords—the total power used by all devices you have connected to the extension cord's outlet must never exceed the power rating (watts/amperes) for the extension cord. Excessive loads can cause the insulation on the cord to heat up and eventually melt through.
- Before using the unit in a foreign country, consult with your retailer, the nearest Roland Service Center, or an authorized Roland distributor, as listed on the "Information" page.
- Always turn the unit off and unplug the power cord before attempting installation of the circuit board (AR-NT1/AR-NT1R).
- Do not put anything that contains water (e.g., flower vases) on this unit. Also, avoid the use of insecticides, perfumes, alcohol, nail polish, spray cans, etc., near the unit. Swiftly wipe away any liquid that spills on the unit using a dry, soft cloth.

⚠ CAUTION

- The unit should be located so that its location or position does not interfere with its proper ventilation.
- Always grasp only the plug on the power-supply cord when plugging into, or unplugging from, an outlet or this unit.
- At regular intervals, you should unplug the power plug and clean it by using a dry cloth to wipe all dust and other accumulations away from its prongs. Also, disconnect the power plug from the power outlet whenever the unit is to remain unused for an extended period of time. Any accumulation of dust between the power plug and the power outlet can result in poor insulation and lead to fire.
- Try to prevent cords and cables from becoming entangled. Also, all cords and cables should be placed so they are out of the reach of children.
- Never climb on top of, nor place heavy objects on the unit.
- Never handle the power cord or its plugs with wet hands when plugging into, or unplugging from, an outlet or this unit.
- Before moving the unit, disconnect the power plug from the outlet, and pull out all cords from external devices.
- Before cleaning the unit, turn off the power and unplug the power cord from the outlet (p. 15).
- Whenever you suspect the possibility of lightning in your area, pull the plug on the power cord out of the outlet.
- Install only the specified circuit board(s) (AR-NT1/AR-NT1R). Remove only the specified screws (p. 15).
- Keep the included Rubber Feet in a safe place out of children's reach, so there is no chance of them being swallowed accidentally.
- Keep any screws you may remove and the included screws in a safe place out of children's reach, so there is no chance of them being swallowed accidentally.

IMPORTANT NOTES

Power Supply

- Do not connect this unit to same electrical outlet that is being used by an electrical appliance that is controlled by an inverter (such as a refrigerator, washing machine, microwave oven, or air conditioner), or that contains a motor. Depending on the way in which the electrical appliance is used, power supply noise may cause this unit to malfunction or may produce audible noise. If it is not practical to use a separate electrical outlet, connect a power supply noise filter between this unit and the electrical outlet.
- Before connecting this unit to other devices, turn off the power to all units. This will help prevent malfunctions and/or damage to speakers or other devices.
- Although the LCD and LEDs are switched off when the POWER switch is switched off, this does not mean that the unit has been completely disconnected from the source of power. If you need to turn off the power completely, first turn off the POWER switch, then unplug the power cord from the power outlet. For this reason, the outlet into which you choose to connect the power cord's plug should be one that is within easy reach and readily accessible.

Placement

- Using the unit near power amplifiers (or other equipment containing large power transformers) may induce hum. To alleviate the problem, change the orientation of this unit; or move it farther away from the source of interference.
- This device may interfere with radio and television reception. Do not use this device in the vicinity of such receivers.
- Noise may be produced if wireless communications devices, such as cell phones, are operated in the vicinity of this unit. Such noise could occur when receiving or initiating a call, or while conversing. Should you experience such problems, you should relocate such wireless devices so they are at a greater distance from this unit, or switch them off.
- When moved from one location to another where the temperature and/or humidity is very different, water droplets (condensation) may form inside the unit. Damage or malfunction may result if you attempt to use the unit in this condition. Therefore, before using the unit, you must allow it to stand for several hours, until the condensation has completely evaporated.
- Depending on the material and temperature of the surface on which you place the unit, its rubber feet may discolor or mar the surface. You can place a piece of felt or cloth under the rubber feet to prevent this from happening. If you do so, please make sure that the unit will not slip or move accidentally.

Maintenance

- For everyday cleaning wipe the unit with a soft, dry cloth or one that has been slightly dampened with water. To remove stubborn dirt, use a cloth impregnated with a mild, non-abrasive detergent. Afterwards, be sure to wipe the unit thoroughly with a soft, dry cloth.
- Never use benzine, thinners, alcohol or solvents of any kind, to avoid the possibility of discoloration and/or deformation.

Additional Precautions

- Unfortunately, it may be impossible to restore the contents of data that was stored on a memory card once it has been lost. Roland Corporation assumes no liability concerning such loss of data.
- Use a reasonable amount of care when using the unit's buttons, sliders, or other controls; and when using its jacks and connectors. Rough handling can lead to malfunctions.
- Never strike or apply strong pressure to the display.
- When connecting / disconnecting all cables, grasp the connector itself—never pull on the cable. This way you will avoid causing shorts, or damage to the cable's internal elements.
- A small amount of heat will radiate from the unit during normal operation.
- To avoid disturbing your neighbors, try to keep the unit's volume at reasonable levels. You may prefer to use headphones, so you do not need to be concerned about those around you (especially when it is late at night).
- When you need to transport the unit, package it in the box (including padding) that it came in, if possible. Otherwise, you will need to use equivalent packaging materials.
- Use a cable from Roland to make the connection. If using some other make of connection cable, please note the following precautions.
 - Some connection cables contain resistors. Do not use cables that incorporate resistors for connecting to this unit. The use of such cables can cause the sound level to be extremely low, or impossible to hear. For information on cable specifications, contact the manufacturer of the cable.

Before Using Cards

Using DATA Cards

- Carefully insert the DATA card all the way in—until it is firmly in place.

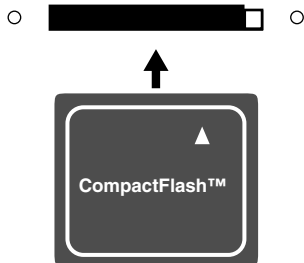

- Never touch the terminals of the DATA card. Also, avoid getting the terminals dirty.
- This unit's memory card slot accepts CompactFlash memory cards. Microdrive storage media are not compatible.
- Memory cards are constructed using precision components; handle the cards carefully, paying particular note to the following.
 - To prevent damage to the cards from static electricity, be sure to discharge any static electricity from your own body before handling the cards.
 - Do not touch or allow metal to come into contact with the contact portion of the cards.
 - Do not bend, drop, or subject cards to strong shock or vibration.
 - Do not keep cards in direct sunlight, in closed vehicles, or other such locations (storage temperature: -25 to 85° C).
 - Do not allow cards to become wet.
 - Do not disassemble or modify the cards.

Copyright

- Unauthorized recording, distribution, sale, lending, public performance, broadcasting, or the like, in whole or in part, of a work (musical composition, video, broadcast, public performance, or the like) whose copyright is held by a third party is prohibited by law.
- Do not use this unit for purposes that could infringe on a copyright held by a third party. We assume no responsibility whatsoever with regard to any infringements of third-party copyrights arising through your use of this unit.

Contents

USING THE UNIT SAFELY	3
IMPORTANT NOTES	5
Main Features	11
Panel Descriptions.....	12
Front Panel.....	12
Rear Panel	14
Installing an Option Board.....	15
Installation de la carte facultative (French language for Canadian Safety Standard)	16
Installation	17
Attaching the Rubber Feet.....	17
Rack Mounting (Important Notes on Heat Radiation)	17
Attaching the Card Protector.....	18
Examples of Usage and Connection for the AR-3000R.....	19
Together with Other Equipment (System Examples)	19
Using the Control Input and Output Terminals.....	19
Using the MIDI Connectors.....	20
Using the RS-232C Connector	21
Connections (Connection Methods)	22
Dual Mono Mode	22
AR-LINK	22
What You Can Do (Usage Tips)	23
Repeat Playback of the Same Phrase.....	23
Playing a Variety of Phrases in Succession	23
Turning the Power On and Off.....	24
Turning On the Power	24
Turning Off The Power.....	24
Easy Setting Operations!—EZ SETUP	25
What Is EZ Setup?	25
What You Can Do with EZ Setup	25
Examples of EZ Setup Use	27
Recording Audio.....	27
Cards Compatible with the AR-3000R.....	30
Types of Usable Cards	30
Card Storage Times and Number of Phrases	30
Formatting a Card	31
Important Notes on Handling Cards.....	33
Card Compatibility with Other Models in the AR Series.....	34
Using Cards Formatted on Earlier Model Units with the AR-3000R	34
Using Cards Formatted on the AR-3000R with Earlier Models.....	34
The Display	35
Viewing the Basic Screen.....	35
Screen During Audio Phrase Playback	35
Screen During MIDI Phrase Playback.....	35
Screen During Pattern Phrase or Song Phrase Playback.....	35
Viewing the 7-segment Display	36
Display-related Settings.....	37
Adjusting the Contrast	37
Making the Display Go Dark	38

Recording Audio	40
Recording Units—Phrases	40
Connecting Equipment	40
Procedure for Recording	41
Enabling Recording Standby	41
Required Settings for Recording Audio Signals (Recording Settings)	42
Starting and Ending Recording.....	49
Checking What You Recorded	50
Information Recorded on the Card	50
Important Note: About Setting Information Imported from a Card.....	50
Playback Using the Panel on the Unit (Manual Playback)	51
Modifying Recorded Phrases (Phrase Settings).....	54
Adding Information to Individual Phrases (Phrase Information)	54
Three Useful Playback Modes for Phrase Settings.....	54
Play Volume (%).....	54
Delay Time (00s 00f to 59s 29f)	55
Playback Point (Start and End)	55
Repeat Play (Repeat, Repeat Interval).....	57
Loop Play (Loop, Loop 1, Loop 2, Crossfade Time).....	57
Fade (Fade In and Fade Out)	58
Control Out	59
Changing the Playback Tempo for MIDI Phrases (MIDI Playback Tempo)	60
Phrase Name	60
Creating Combinations of Phrases (Phrase Combination).....	62
Combinations of Phrase Units (Pattern Phrases).....	62
Time-based Combinations (Song Phrases).....	65
Modifying Phrases Themselves (Phrase Edit).....	67
Deleting a Phrase (Phrase Delete).....	67
Deleting Audio Outside the Playback Points (Phrase Truncate)	67
Copying a Phrase (Phrase Copy)	68
Dividing a Phrase (Phrase Divide)	69
Joining Phrases (Phrase Combine).....	70
Expanding or Compressing the Playback Time Without Changing the Pitch (Time Stretch)...	71
Converting a Phrase’s Recording Settings (Phrase Convert)	72
Phrase Information/Phrase Setting Correspondence Table	75
Making Settings and Edits for Individual Cards	76
Making a Card Usable on the AR-3000R (Card Format).....	76
Deleting All Phrases on a Card (Card Delete)	76
Copying a Card (Card Copy)	76
Copying Just the Settings (Setting Copy)	77
Protecting a Card (Card Protect).....	77
Changing the Name of a Card (Card Name)	77
Making Cards for Legacy Models Usable on the AR-3000R (Card Convert).....	78
Card Conversion Chart/Conversion Error Chart	80
Recording and Playing MIDI Data (MIDI Phrases).....	82
What Are MIDI Phrases?	82
Connecting Equipment	82
Unit Settings.....	82
Starting and Ending Recording.....	83
Playback of MIDI Phrases	84
Playback Procedures.....	84

Controlling the AR-3000R from an External Device (Control Input Terminals).....85

What Is No-voltage/Make-contact?	85
Types of Control Input Playback	85
Type of Control Input Recording	86
Assigning a Phrase to a Port and Playing It Back (Direct Playback)	86
What Is Direct Playback?/Uses and Applications	86
Connecting External Equipment.....	86
Operational Specifications for Direct Playback	86
AR-3000R Settings.....	87
Playing Back Phrases in the Order They Are Selected (Program Playback)	89
What is Program Playback?/Uses and Applications.....	89
Connecting External Equipment.....	90
Operational Specifications for Program Playback.....	90
Display Indications During Program Playback.....	91
AR-3000R Settings.....	91
Specifying Phrase Numbers in Binary Notation (Binary Playback)	92
What is Binary Playback?/Uses and Applications	92
Connecting External Equipment.....	93
Operational Specifications of Binary Playback.....	93
AR-3000R Settings.....	94
To Specify Phrases With Binary Signals	95
Phrase Number/Binary Signal Correspondence Table.....	96
Controlling Recording with the Control Terminals (Binary Recording)	98
What is Binary Recording/Uses and Applications.....	98
Connecting Equipment	98
Operational Specifications for Binary Recording.....	98
AR-3000R Settings.....	100
To Specify Phrases With Binary Signals	101

Controlling Another Device with the AR-3000R (Control Output Terminal).....102

Starting Another Device (Busy Out).....	102
What Is a Busy Out Signal?/Equipment Connections	102
AR-3000R Settings.....	103
Controlling Another Device (Control Out).....	104
What Is a Control Out Signal?/Equipment Connections.....	104
AR-3000R Settings.....	104

Controlling the AR-3000R Using MIDI Signals (MIDI Control)105

What Is MIDI Control?/What You Can Do with MIDI Control.....	105
Glossary of Selected MIDI Terms	105
Playback of Phrases Using MIDI Signals	105
Connecting External Equipment.....	106
AR-3000R Settings.....	106
Operation Procedures.....	109
Synchronizing Operation to an External MIDI Instrument – 1 (MMC)	110
What Is MMC?/Remote Control from Another Device.....	110
Connecting External Equipment.....	110
AR-3000R Settings.....	110
Operation Procedures.....	112
Synchronizing Operation to an External MIDI Instrument – 2 (MMC and MTC)	112
What Is MTC?/Synchronized Playback with Video Equipment and Other Devices	112
Connecting External Equipment.....	113
AR-3000R Settings (When the AR-3000R Is the Slave)	113
Operation Procedures.....	116
AR-3000R Settings (When the AR-3000R Is the Master)	116
Operation Procedures.....	117
MTC Offset Setting	118

Controlling the AR Using the RS-232C Connector119
 What's the RS-232C Connector? /What You Can Do with the RS-232C Connector..... 119
 Connecting Equipment 119
 Baud Rate Setting 119
 Available Documentation for the RS-232C..... 119

**Playing Two Units's Worth of Data on the Left and Right
 (Dual Mono Mode)120**
 What Is the Dual Mono Mode? /Equipment Connections 120
 AR-3000R Settings 120
 Operation Procedures 121

**Synchronized Recording and Playback with Multiple AR Units
 (AR-LINK)123**
 What Is AR-LINK? /What You Can Do Using AR-LINK..... 123
 Synchronized Audio Phrase Playback with AR-LINK Signals 123
 Example of Connecting to an External Device 123
 Unit Settings..... 124
 Recording Procedure 124
 Playback Procedure 124

Other Useful Functions During Phrase Playback125
 Line Out (Thru) Setting During Phrase Playback..... 125
 Handy Uses of Line Thru 125
 Line Thru Settings 125
 Adjusting the Sound Quality During Audio Phrase Playback (Equalizer) 126
 Keeping the Output Volume Unchanged (Output Volume Thru)..... 127

Troubleshooting.....129

Error messages132

Cards134
 Card-specific Audio Recording Time Chart 134
 Settings When a Card Is Formatted 135
 Recorded Phrase Data..... 136

Terminals137
 Specifications of the Control Input/Output Terminals 137
 RS-232C Connector Specifications 137
 AR-LINK Connectors Specifications 138

MIDI Implementation139

Specification.....147
 Input/Output Standard..... 149
 Dimensions 149

Index.....150

Main Features

High-quality Recording and Playback

Thanks to Roland's innovative RDAC system, you can enjoy high-quality, 24-bit recording and playback at 48 kHz using less data. You can select recording settings that suit the situation and the capacity of the card (sampling frequency: 6 levels, recording mode: 5 levels). This ensures support for recording and playback in a variety of situations and uses. What you record and the settings are all saved on the card, so you can change situations rapidly simply by changing cards. You can record and play back up to 2,000 phrases (when using two cards).

Audio Recording System with No Moving Parts

An audio recording system that uses CF cards and has no moving parts is employed. The system has no rotating parts or drive mechanism, so it's practically maintenance free. This makes for outstanding durability with no loss of sound quality.

Digital In Jack

In addition to a Line In jack (analog) and Mic jack, the unit also features a Digital In jack. This means you can record audio phrases of even higher sound quality by connecting the unit to a digital-output device.

Large screen, Easy-to-understand Messages, and EZ Setup Feature Assure Simple Settings and Operation

The large display and easy-to-understand messages make it simple to make settings.

The unit also has a built-in EZ Setup feature that lets you make settings interactively.

You'll appreciate the impressive power this provides when you're using the AR-3000R for the first time, or when you need to change the settings in a hurry during play.

A Full Array of Editing Features for Modifying Phrases the Way You Want

You can use the AR-3000R like a sampler to edit and modify recorded material, including dividing, joining, and stretching the time. Nondestructive editing is possible, so you can modify the material without worrying about loss.

Two-unit Playback with a Single Unit-Dual Mono Mode

The Dual Mono mode lets you manipulate the left and right channels independently, and play back mono audio phrases individually. This means you can play back material for two units on a single AR-3000R. You can also play back separate phrases on the left and right channels either simultaneously, or shifted.

Built-in 2-band Equalizer

The unit features an internal 2-band equalizer for audio-phrase effects. This enables on-site correction of the sonic field.

A Variety of Control Jacks for a Wide Range of Playback Methods

As connectors to use for control, the unit features a Control In jack, MIDI connectors, an RS-232C port, and AR-LINK connectors. This lets you select from a variety of playback methods and create systems matched to usage and situations.

MIDI Connectors Allow for Play of Musical Instruments and Syncing with Video

Since the unit is equipped with MIDI connectors, you can record and play back MIDI signals. You can play an electronic musical instrument automatically, just like playing back an audio phrase.

Control of recording/playback using MIDI signals is also supported. This means you can use MTC and MMC signals to obtain recording/playback that is synchronized to video and other external devices.

Multi-track Operation-AR-LINK Feature

The AR-LINK feature lets you link the unit to up to 32 other units to create a completely synchronized multi-track system.

Conversion Feature for Using Data from Legacy Models

Performing conversion with the Card Conversion feature makes it possible for the AR-3000R to utilize cards used with the earlier AR-2000/100 models, or to use cards created with the AR-3000R on earlier models. This bidirectional data exchange lets you make effective use of materials and data.

Panel Descriptions

Front Panel

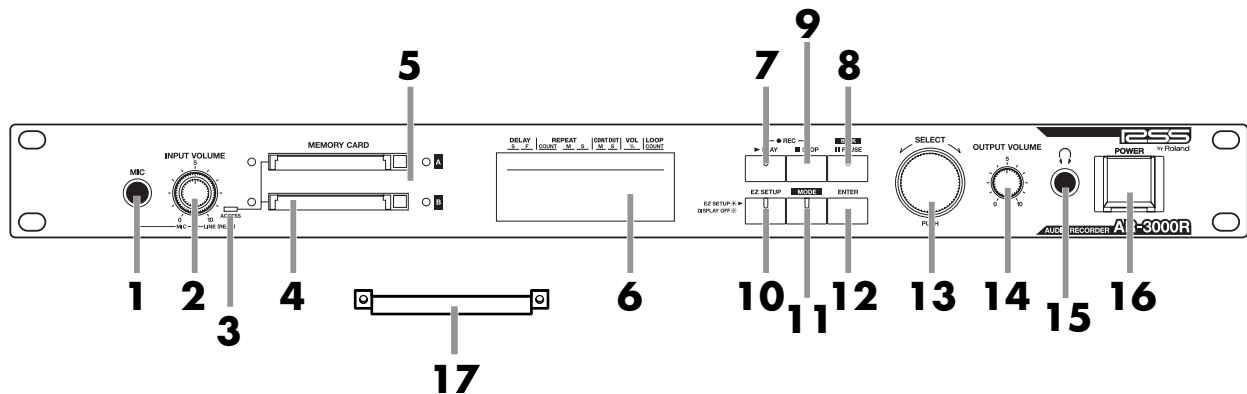

1. Mic In Jack

This is for connecting a microphone during audio recording.
→ “Recording Audio” (p. 40)

2. INPUT VOLUME Knobs

The outer control adjusts the volume level of the signal input to the Line In jack.
The inner control adjusts the microphone-input volume level.

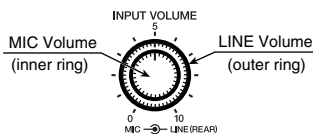

→ “Recording Audio” (p. 40)

NOTE

The volume level of signals input to the Digital In jack cannot be changed.

3. Card Access Indicator

This lights up when the unit reads or writes to a card.

NOTE

When the CF card drive is in operation (that is, when the access indicator is illuminated), do not try to take out the card or turn off the power. Doing so may damage the card.

4. Card Slots

NOTE

Do not insert any object other than a CF card (such as a wire, coin, or different type of card) into the card slots. Doing so may damage the unit.

5. Card Eject Buttons

6. Display

→ “Viewing the Basic Screen” (p. 35)

7. PLAY Button and PLAY Indicator







- Pressing the PLAY button plays back a phrase. When playback is paused, pressing the PLAY or PAUSE button restarts playback.
- Holding down the STOP button and pressing the PLAY button puts the unit in recording standby. Pressing the PLAY or PAUSE button while in this state starts recording.

8. PAUSE/BACK Button and PAUSE Indicator

- Pressing the PAUSE button during playback of an audio phrase pauses playback. Playback resumes when the PLAY or PAUSE button is pressed again.
- Pressing the PLAY or PAUSE button while in the recording-standby state starts recording.
- When you are making settings, this button is used to make the insertion point (highlighted) go back one step.





●About When the Indicators Light/Flash

When Playing Back/Recording

State	PLAY button indicator	PAUSE button indicator
During Playback	Lights in green 	Extinguished
During Pause (Playback)	Flashes in green 	Flashes in green 
During Recording Standby	Flashes in red 	Flashes in red 
During Recording	Lights in red 	Extinguished

- “Recording Audio” (p. 40)
- “Playback Using the Panel on the Unit (Manual Playback)” (p. 51)

When Sync Source is set to MTC

State	PLAY button indicator	PAUSE button indicator
During Pause (Playback)	Lights in green 	Lights in orange 
During Recording Standby	Lights in red 	Lights in orange 

- “Controlling the AR-3000R Using MIDI Signals (MIDI Control)” (p. 105)

9. STOP Button

- Pressing the STOP button stops phrase playback or recording, extinguishing the PLAY indicator.
- Holding down the STOP button and pressing the PLAY button puts the unit in recording standby.

10. EZ SETUP Button and EZ SETUP Indicator

This activates the EZ Setup feature, which lets you make settings interactively.

Use this feature if you’re using the AR-3000R for the first time, or when you need to change the settings in a hurry during play.

The indicator lights up when EZ Setup is active.

→ “Easy Setup and Operation!–EZ Setup” (p. 25)

11. MODE Button and MODE Indicator

For entering the mode for making settings. The indicator lights up while settings are made.

12. ENTER Button

13. SELECT Dial (Doubles As SELECT Button)

This is used for such operations as selecting phrases and choosing setting items.

14. OUTPUT VOLUME Knob

This adjusts the volume level of the final output (at the audio output jacks).



To prevent incorrect operation, you can disable this control and set the volume at a fixed level.

→ “Keeping the Output Volume Unchanged (Output Volume Thru)” (p. 127)

15. Headphones Jack

This is for connecting headphones for monitoring recording and playback.



The headphones volume level is adjusted with the OUTPUT VOLUME control (the same as for the final volume [the audio output jacks]).

When you activate the Volume Thru feature, you can use the OUTPUT VOLUME control to adjust the headphones volume even when the OUTPUT VOLUME control has been deactivated.

16. POWER Switch

Turn the AR-3000R’s power on and off.

- * *If you need to turn off the power completely, first turn off the POWER switch, then unplug the power cord from the power outlet. Refer to **Power Supply** (p. 5).*

17. Card Protector (Included)

This allows you to prevent the card being removed by mistake.

Rear Panel

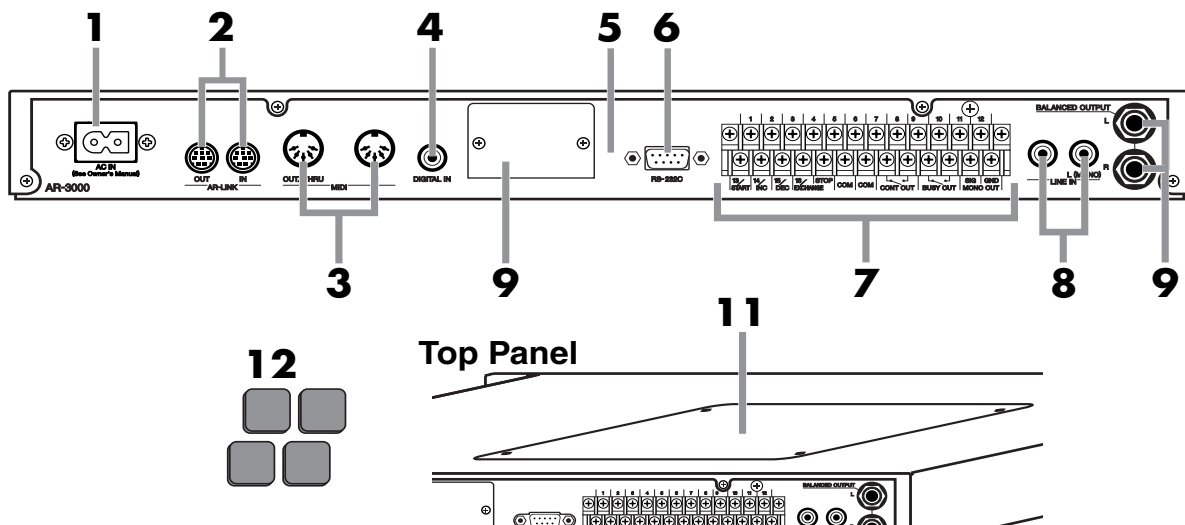

1. AC Inlet

This is for connecting the included AC power cord. Connect it securely so that it doesn't come loose.

(Refer to p. 147 – for power requirements)



The unit should be connected to a power source only of the type maked on the side of unit.

2. AR-LINK Connectors (OUT and IN)

These are for connecting the AR units to each other when you're using more than one AR unit at the same time.

→ "Synchronized Recording and Playback with Multiple AR Units (AR-LINK)" (p. 123)

3. MIDI Connectors (OUT/THRU and IN)

These are used to make the connections when you operate the AR with MIDI signals for recording MIDI phrases, performing MIDI control, and so on.

- MIDI IN: This receives MIDI information from another MIDI instrument.
- MIDI OUT: This sends MIDI information from the AR-3000R.
- MIDI THRU: This sends, unchanged, MIDI information received by MIDI IN.

On the AR-3000R, a single connector doubles in use for MIDI OUT and MIDI THRU. When shipped from the factory, the connector is set to "OUT." You can change the function of the connector as required.

→ "Recording and Playing MIDI Data" (p. 82)

→ "Controlling the AR with MIDI Signals (MIDI control)" (p. 105)

4. DIGITAL IN Jack (Coaxial, S/P DIF, EIAJ CP-1201-compliant)

This is used when recording audio from a device equipped with a digital audio-output jack.

5. Ground Terminal

Depending on the circumstances of a particular setup, you may experience a discomforting sensation, or perceive that the surface feels gritty to the touch when you touch this device, microphones connected to it, or the metal portions of other objects. This is due to an infinitesimal electrical charge, which is absolutely harmless. However, if you are concerned about this, connect the ground terminal (see figure) with an external ground. When the unit is grounded, a slight hum may occur, depending on the particulars of your installation. If you are unsure of the connection method, contact the nearest Roland Service Center, or an authorized Roland distributor, as listed on the "Information" page.

Unsuitable places for connection

- Water pipes (may result in shock or electrocution)
- Gas pipes (may result in fire or explosion)
- Telephone-line ground or lightning rod (may be dangerous in the event of lightning)

6. RS-232C Connector

This is used when connecting the AR-3000R to a computer or the like for exchanging signals.

→ "Controlling the AR Using the RS-232C Connector" (p. 119)

7. Control Input/Output Terminals

These are used for connecting to external control devices.

- Controlling the AR-3000R with Signals from an External Control Device
→ "Controlling the AR-3000R from an External Device (Control Input Terminals)" (p. 85)
- Controlling an External Device with Signals from the AR-3000R
→ "Controlling Another Device with the AR-3000R (Control Output Terminals)" (p. 102)

8. LINE IN Jack

This is used when recording audio from a device equipped with an analog audio-output jack.

9. Audio Output Jacks (BALANCED OUTPUT)

These are the final audio output jacks. They are used for connection to a power amp or the like. Both balanced and unbalanced connections are possible.

* This instrument is equipped with balanced (TRS) type jacks. Wiring diagrams for these jacks are shown below. Make connections after first checking the wiring diagrams of other equipment you intend to connect.

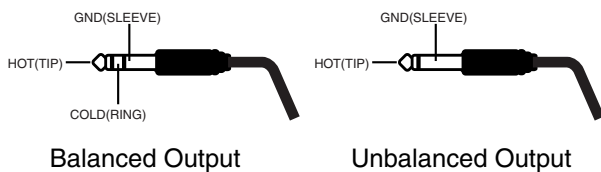

NOTE

When connection cables with resistors are used, the volume level of equipment connected to the inputs (LINE IN Jack) may be low. If this happens, use connection cables that do not contain resistors, such as those from the Roland PCS series.

10. Option Board Slot

This is the recess for installing an option board.
→ "Installing an Option board"

NOTE

When installing, be sure to refer to the owner's manual for the option board.

11. Option Board Space

This is where an option board is installed.
→ "Installing an Option board"

NOTE

When installing, be sure to refer to the owner's manual for the respective option board.

12. Rubber Feet (Included Items)

→ "Attaching the Rubber Feet (Included Items)" (p. 17)

Installing an Option Board

NOTE

When installing, be sure refer to the owner's manual for the respective option board.

Top Panel

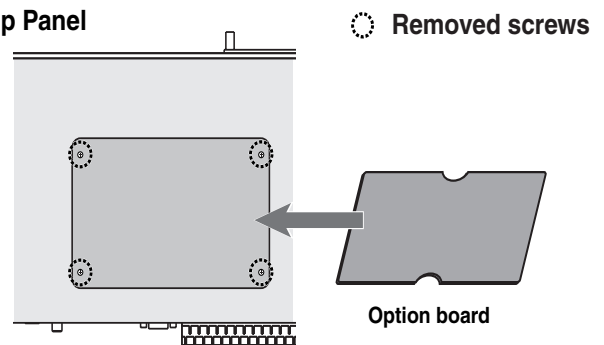

Rear Panel

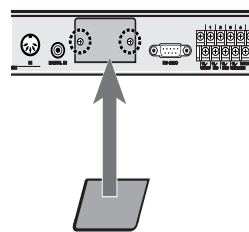

Important Notes on Installation

- Before installing the board, switch off the power to the equipment and unplug the power cord from the power outlet.
- Remove only the specified screws.
- Be careful not to let removed screws fall into the unit.
- After you have removed the panel, cover, and screws, do not leave them off. When you have finished installing the option board, be sure to reattach the panel, cover, and screws.
- Be careful not to cut your hand on the opening for installing the board.
- After installation, if the unit fails to power up when you switch on the power, contact your Roland Service Station.
- To avoid the risk of damage to internal components that can be caused by static electricity, please carefully observe the following whenever you handle the board.
 - Before you handle the circuit board, first touch the front panel of the AR-3000R, and while maintaining contact with the front panel, pick up the circuit board. This discharges any static electricity that has accumulated in your body and clothing.
 - When handling the board, grasp it only by the panel or the board's edges. Avoid touching any of the electronic components or connectors.
 - When handling the board, grasp it only by the panel or the board's edges. Avoid touching any of the electronic components or connectors.
 - Before you connect any cables, make sure they do not carry a static electricity charge. Such charges can be

Panel Descriptions

transmitted, for example, if the other end of the cable has been in contact with a carpet (or other object) where there is a static electricity buildup.

- Save the bag in which the board was originally shipped, and put the board back into it whenever you need to store or transport it.
- Do not touch any of the printed circuit pathways or connection terminals.
- Never use excessive force when installing a circuit board. If it doesn't fit properly on the first attempt, remove the board and try again.
- When circuit board installation is complete, double-check your work.

- Always turn the unit off and unplug the power cord before attempting installation of the circuit board (model no. AR-NT1/AR-NT1R).
- Install only the specified circuit board(s) (model no. AR-NT1/AR-NT1R). Remove only the specified screws.
- When turning the unit upside-down, get a bunch of newspapers or magazines, and place them under the four corners or at both ends to prevent damage to the buttons and controls. Also, you should try to orient the unit so no buttons or controls get damaged.
- When turning the unit upside-down, handle with care to avoid dropping it, or allowing it to fall or tip over.

French language
for Canadian Safety Standard

Installation de la carte facultative (French language for Canadian Safety Standard)

Pour de plus amples renseignements sur la procédure d'installation, reportez-vous à la documentation spécifique à la carte facultative.

Top Panel

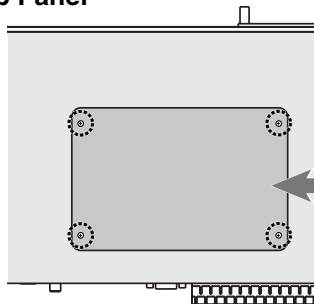

○ Vis retirées



Option board

Rear Panel

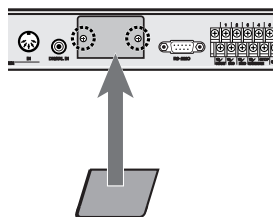

Remarques importantes sur l'installation

- Avant d'installer la carte, éteignez l'équipement et débranchez le cordon d'alimentation de la prise.
- Retirez uniquement les vis indiquées.
- Faites attention de ne pas laisser les vis tomber dans l'unité.
- Après avoir retiré le panneau, le couvercle et les vis, ne les laissez pas ainsi. Une fois terminée l'installation de la carte facultative, assurez-vous de remettre le panneau, le couvercle et les vis en place.
- Faites attention de ne pas vous couper sur l'ouverture d'installation de la carte.

- Après l'installation, si l'unité ne se remet pas en marche lorsque vous la rallumez, communiquez avec le centre de service Roland.
- Veuillez suivre attentivement les instructions suivantes quand vous manipulez la carte afin d'éviter tout risque d'endommagement des pièces internes par l'électricité statique.
 - Toujours toucher un objet métallique relié à la terre (comme un tuyau par exemple) avant de manipuler la carte pour vous décharger de l'électricité statique que vous auriez pu accumuler.
 - Lorsque vous manipulez la carte, la tenir par les côtés. Évitez de toucher aux composants ou aux connecteurs.
 - Lorsque vous manipulez la carte, la tenir par les côtés de la plaque ou par les côtés du circuit imprimé. Évitez de toucher aux composants ou aux connecteurs.
 - Avant de connecter tout câble, assurez-vous qu'il ne contient aucune charge d'électricité statique. De telles charges peuvent être transmises, par exemple, si l'autre extrémité du câble touche à un tapis (ou autre objet) où il y a accumulation d'électricité statique.
 - Conservez le sachet d'origine dans lequel était la carte lors de l'envoi et remettez la carte dedans si vous devez la ranger ou la transporter.
- Ne pas toucher aux circuits imprimés ou aux connecteurs.
- Ne jamais forcer lors de l'installation de la carte de circuits imprimés. Si la carte s'ajuste mal au premier essai, enlevez la carte et recommencez l'installation.
- Quand l'installation de la carte de circuits imprimés est terminée, reverifiez si tout est bien installé.
- Toujours éteindre et débrancher l'appareil avant de commencer l'installation de la carte. (modele no AR-NT1/AR-NT1R).
- N'installez que les cartes de circuits imprimés spécifiées (modele no AR-NT1/AR-NT1R). Enlevez seulement les vis indiquées.

Installation

Attaching the Rubber Feet

Attach these as required, such as when you're using the AR-3000R without mounting it on a rack or the like.

Peel off the double-sided tape from the rubber feet and affix the rubber feet at the locations shown in the following figure.

Bottom chassis

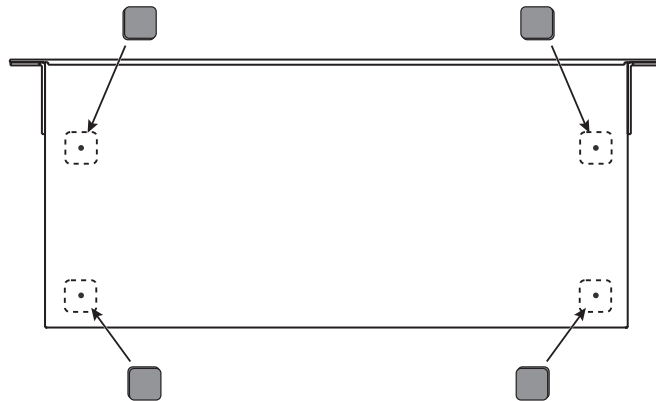

Rack Mounting (Important Notes on Heat Radiation)

When you are mounting the unit on a rack or the like, give attention to the following points to ensure efficient cooling.

- Install in a well-ventilated location.
- Avoid mounting in a sealed rack. Warm air within the rack cannot escape and is sucked into the unit again, making efficient cooling impossible.
- When you are using a stacked mounting arrangement, be especially sure to provide for adequate ventilation within the rack to keep discharged air from being sucked back into the unit. If the back surface of the rack cannot be kept open, then provide a ventilation port or ventilation fan at the upper area of the back surface of the rack, where warm air accumulates.
- When you are using the unit in a portable case or rack, remove the covers from the front and back surfaces of the case, so that the front and back surfaces of the unit are not obstructed.
- If an error message informing you of a dangerous rise in temperature appears (p. 132), then heat-dissipating measures are needed. Refer to the cautions just described and check the installed state of the unit and the rack.

* When placing the unit on the rack, be careful not to pinch your fingers.

* For more information about installation, also see "Placement" in the Important Notes (p. 5).

Attaching the Card Protector

By attaching the Card Protector (supplied) to the AR-3000R, you can prevent the memory card from inadvertently being removed from the AR-3000R.

1

After confirming that the card is securely inserted in the card slot, use the provided screws to attach the Card Protector, as shown in the figure below.

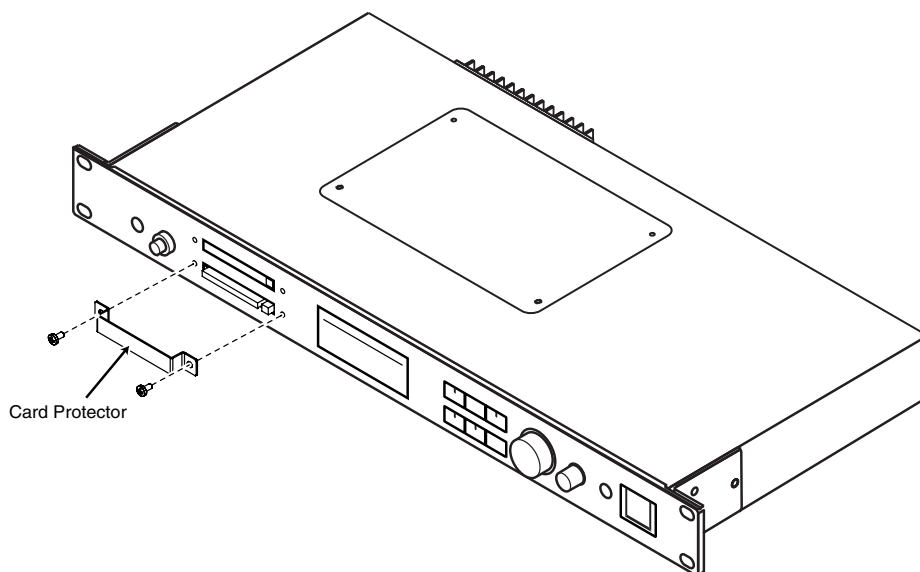

Examples of Usage and Connection for the AR-3000R

You can use the AR-3000R alone or in combination with other AR-3000R units or other equipment to play audio in a wide variety of scenes. This section shows some examples of these. You can use these examples as a starting point for making changes to match your own usage circumstances.

Together with Other Equipment (System Examples)

Using the Control Input and Output Terminals

● Control Input: Messages, explanations, warnings, announcements, effect sounds, and the like are played with high sound quality according to control signals from sensors, buttons, and switches.

 Controlling the AR-3000R from an External Device (Control Input Terminals) → p. 85

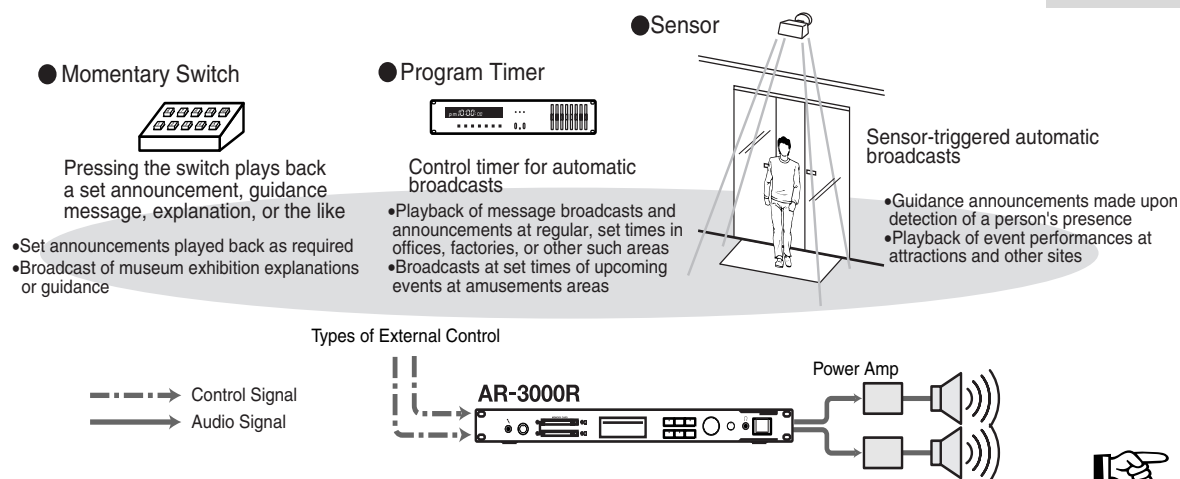

● Control Output: Control signals can be output during or after phrase playback to control an external device.

 Controlling Another Device with the AR-3000R (Control Output Terminals) → p. 102

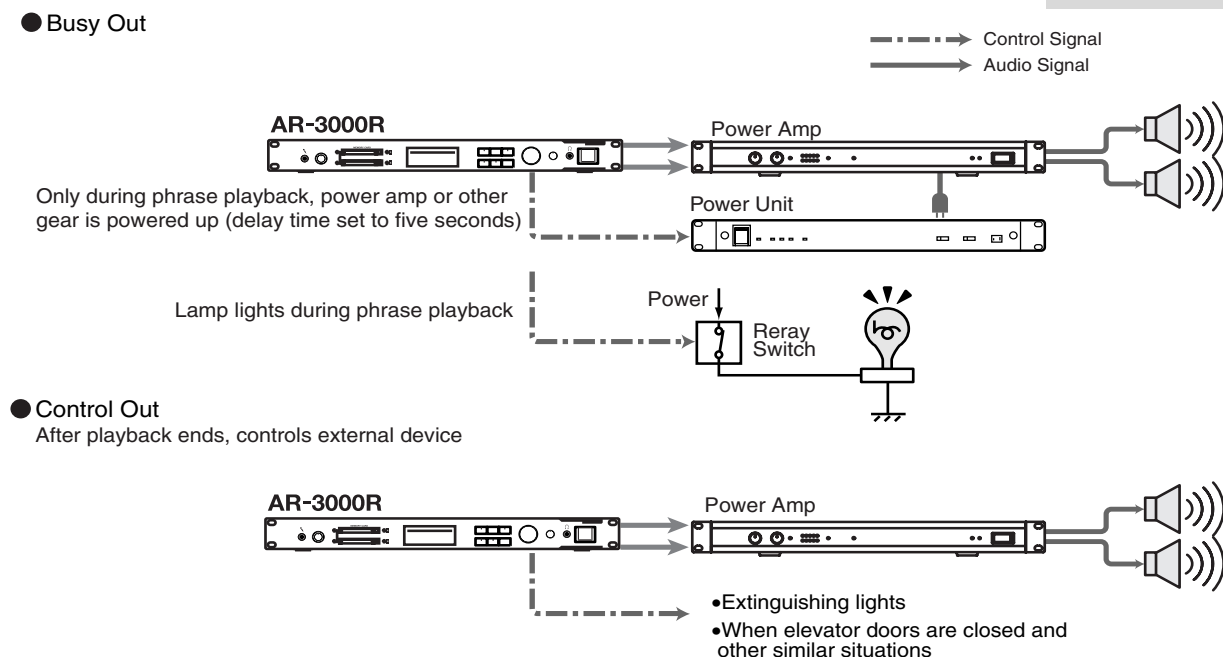

Examples of Usage and Connection for the AR-3000R

Using the MIDI Connectors

● Spatial Expression

With the AR-3000R serving as the master, the MIDI signals it sends out can be used to get a sound module to play background music. Or, you can have sound-effect phrases be played by a slaved AR-3000R. This lets you create sonic fields with six-channel multi-playback.



Controlling the AR-3000R
Using MIDI Signals (MIDI
Control) → p. 105

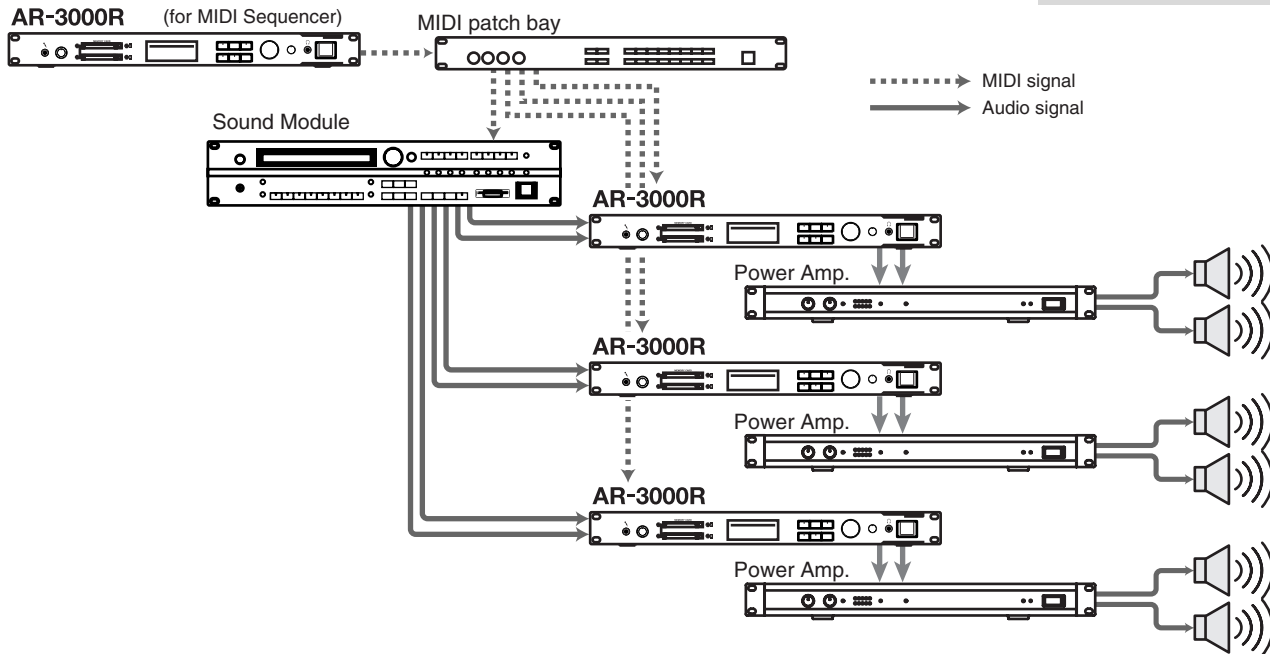

● Sound-field Control

Using batch MIDI control from a switch box, you can change programs on a mixer, equalizer, or the like to control the sonic field.

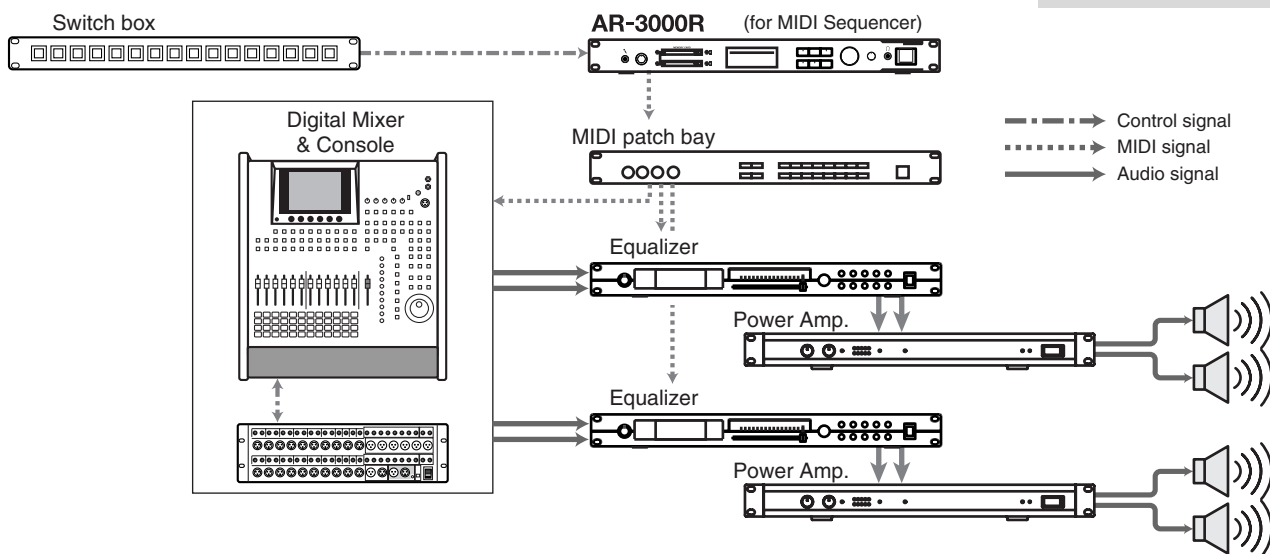

Using the RS-232C Connector

By connecting an RS-232C cable, you can control the AR-3000R from an external control device, such as a computer or touch panel.



Controlling the AR Using the RS-232C Connector → p. 119



●AR Control with a computer

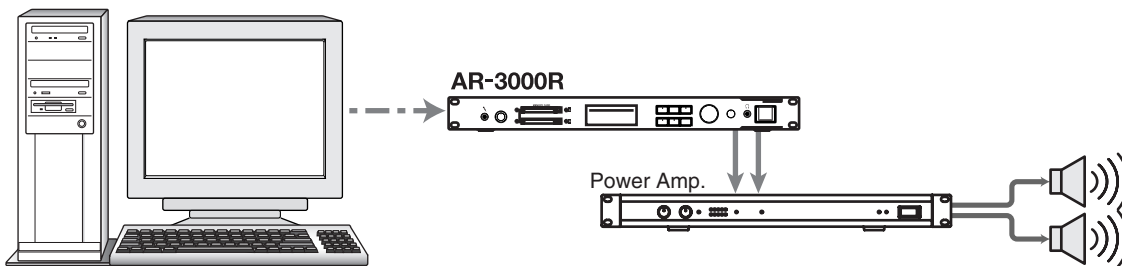

●Explanatory messages and guidance for public facilities and museum exhibits

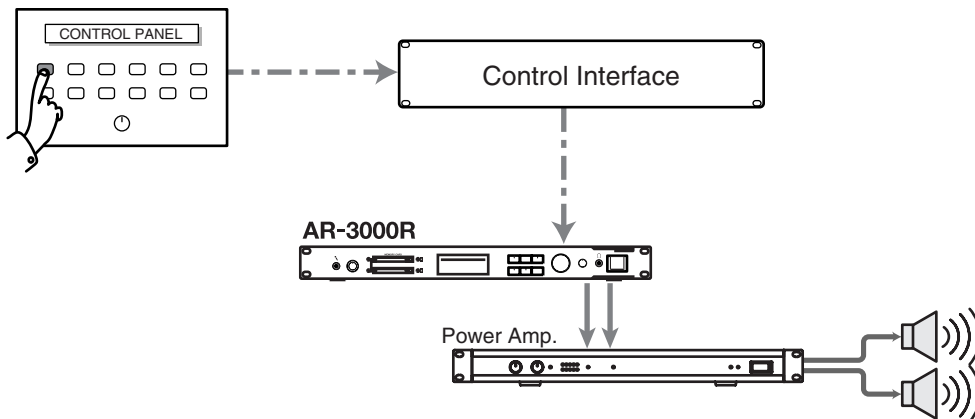

Connections (Connection Methods)

Dual Mono Mode

The Dual Mono mode is a feature for playing different mono audio phrases independently on the left and right channels. This lets you use the unit to play two units's worth of data.

You can also play back separate phrases on the left and right channels simultaneously, or control them individually.

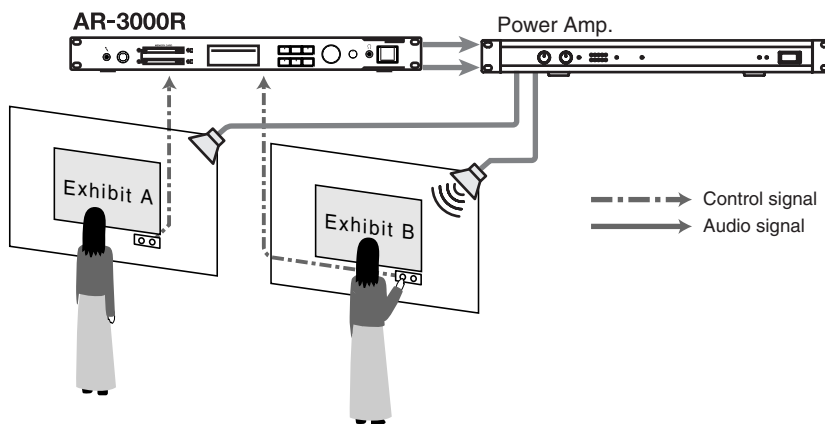

Playing Two Unit's Worth of Data on the Left and Right (Dual Mono Mode) → p. 120

AR-LINK

● Connecting with the AR-LINK Cable

You can operate four AR-3000R units completely in sync as an eight-channel multi-player.

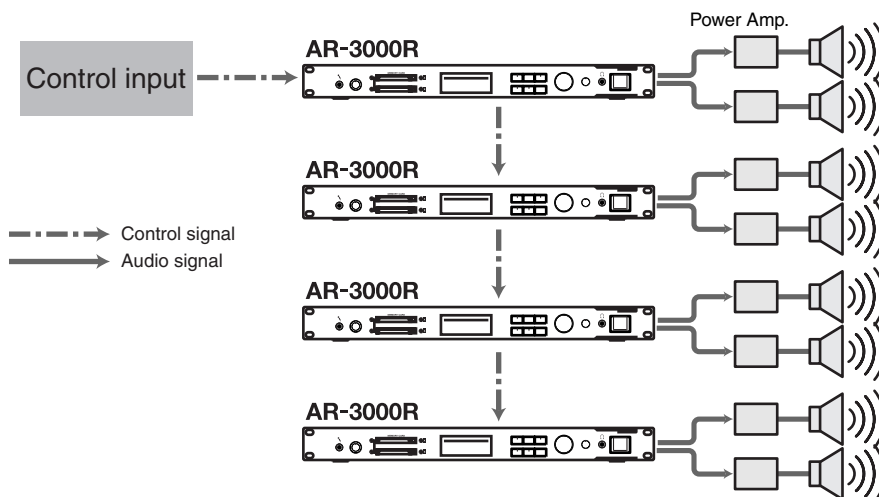

Synchronized Recording and Playback with Multiple AR Units (AR-LINK) → p. 123

What You Can Do (Usage Tips)

Repeat Playback of the Same Phrase

There are several methods for doing this. Choose a playback method that matches your usage conditions.

Setting the Phrase Information for Repeat Play

You can repeat each individual phrase.

You can also do repeat play for a phrase combination (a group of phrases).



Repeat Play → p. 57



Phrase Combinations → p. 62

Inputting a Continuous Make-contact Signal to the Control Input Terminals

You can repeat playback by continuously shorting the control input terminals.

* *With some settings, playback doesn't repeat even when you continuously input a make-contact signal.*

For information, refer to "Controlling the AR-3000R from an External Device (Control Input Terminals)" (p. 85).

Playing a Variety of Phrases in Succession

There are several methods for doing this. Choose a playback method that matches your usage conditions.

Using Phrase Combinations

This continuously plays back stored phrases in succession.



Phrase Combinations → p. 62

Using Direct Playback of Control Input

By inputting control signals to a port number from 1 through 16, you can play back the phrase assigned to the number.



Direct Playback → p. 86

Using Program Playback of Control Input

This successively plays back phrases in preset sequence each time a control signal is input to the START port.



Program Playback → p. 89

Using Binary Playback of Control Input

You can select phrases by inputting binary signals to port numbers 1 through 10, and play the selected phrases in succession each time you input control signals to the START port.



Binary Playback → p. 92

Turning the Power On and Off

Turning On the Power

* Once the connections have been completed (p. 40), turn on power to your various devices in the order specified. By turning on devices in the wrong order, you risk causing malfunction and/or damage to speakers and other devices.

Power on your equipment as described in the following. After the devices are powered on, set the volumes to each connected devices equipment.

Connected devices → AR-3000R → Power Amplifier etc.

- 1 Confirm the volume levels on the AR-3000R and any amp or mixer that is connected turned down to the lowest settings.
- 2 Press the POWER switch to turn on the power.

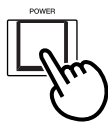

- 3 Watch the display.

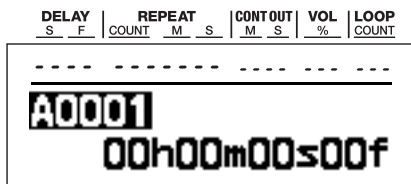

* This display is only an example for illustrative purposes, The content of the display will differ depending on the card settings.

Turning Off The Power

- 1 Confirm the volume levels on the AR-3000R and any amp or mixer that is connected turned down to the lowest settings.
- 2 Switch off the power of the device in the reverse order of that used to switch on the power.
The display will go dark, indicating that the power has been turned off.

NOTE

This unit is equipped with a protection circuit. A brief interval (a few seconds) after power up is required before the unit will operate normally.

NOTE

To avoid risk of electric shock, do not touch the connectors while the unit is in operation.

NOTE

If you need to turn off the power completely, first turn off the POWER switch, then unplug the power cord from the power outlet. Refer to **Power Supply** (p. 5)

Easy Setting Operations!—EZ SETUP

What Is EZ Setup?

On the AR-3000R, settings are normally made by using the MODE button to enter the setting mode, then selecting the needed items from the various menu levels.

EZ Setup is an interactive method for making settings, whereby you first select the target and the feature you want to use, then make the necessary settings, one after another.

Use this feature if you're using the AR-3000R for the first time, if you don't know what items need to be set, or when you need to change the settings in a hurry during play.

What You Can Do with EZ Setup

With EZ Setup, you can make target-specific and function-specific settings like the ones shown below.

A. Creating Cards

1. Creating a New Card (p. 31)
2. Copying a Card (p. 76)
3. Using AR-2000 Cards (p. 78)

B. Recording Phrases

1. Audio Recording (Line Input) (p. 40)
2. Audio Recording (Line + Mic) (p. 40)
3. Audio Recording (Digital Connectors) (p. 40)
4. MIDI Recording (p. 82)

C. Phrase Editing

1. Phrase Information Settings (p. 54)
 - Playback Volume Setting
 - Loop Play
 - Repeat Play
2. Combining Phrase (p. 62)
 - Creating Pattern Phrases
 - Creating Song Phrases
3. Modifying Phrases (p. 67)
 - Deleting Phrases
 - Splitting Phrases

Easy Setting Operations!—EZ SETUP

- Joining Phrases
- Expanding and Compressing Playback Times (Time Stretch)
- Copying Phrases

D. Control from an External Device



1. Playback Using the Screw-on Connectors (p. 85)
 - Selected Playback of Stored Phrases
 - Sequential Playback of Stored Phrases
 - Playback of Specified Phrase Numbers
 - Recording Specified Phrase Numbers
2. Playback Using MIDI Signals (p. 105)
3. Control Using RS-232C (p. 119)

E. Independent playback of L and R channels (p. 120)



F. Synchronizing Multiple Devices



1. Synchronization Using AR-LINK (p. 123)
2. Synchronization Using MIDI (p. 110)

G. LCD Settings



1. Adjusting LCD Contrast (p. 37)
2. LCD Auto Power-off (p. 38)

H. Control Output Signal Settings



1. Signal Settings for Starting Other Equipment (p. 102)
2. Signal Settings for Controlling Other Equipment (p. 104)

I. Line Output Settings



1. Line Thru Settings During Playback (p. 125)
2. Adjusting the Sound Quality of Audio Phrases (p. 126)
3. Locking Output Volume (p. 127)

Examples of EZ Setup Use

This section describes “recording audio” as an example of operations using EZ Setup.

Recording Audio

Refer to “Connecting Equipment” (p. 40) and connect the external equipment.

1 Press the EZ SETUP button.

The EZ SETUP indicator lights up.

2 Turn the SELECT dial to choose the “Recording Phrases” icon, then press the dial.

Present icon location Number of icons on the menu

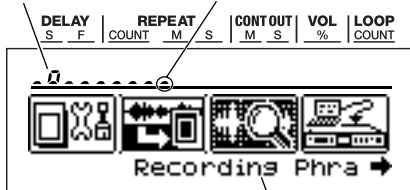

The present screen content and messages are scrolled at the bottom of the screen.

3 Turn the SELECT dial to choose the “Audio Recording (Line Input)” icon, then press the dial.

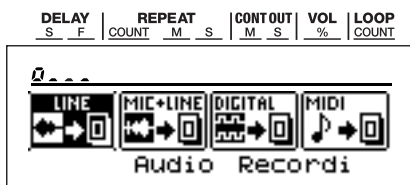

4 Turn the SELECT dial to choose “Card to Record (A/B),” then press the dial.

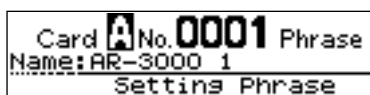

MEMO

In each step, each press of the PAUSE (BACK) button lets you go back one screen.

Easy Setting Operations!—EZ SETUP

5 Turn the SELECT dial to choose the phrase number to record, then press the dial.

6 Turn the SELECT dial to choose the recording type (Stereo or Mono), then press the dial.



7 Turn the SELECT dial to choose the RDAC grade (High-quality, Normal, or Extended-time).

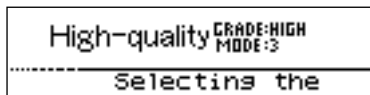

When you press the SELECT dial, a screen like the one below appears.

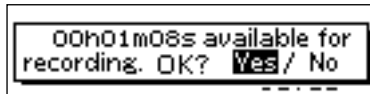

8 Turn the SELECT dial to choose "YES," then press the ENTER button to enter recording standby.



9 Use the INPUT VOLUME control to adjust the recording level, then press the ENTER button to start recording.



10 Press the STOP button to stop recording.

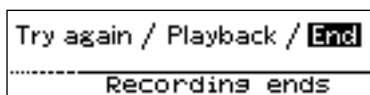

11

Turn the SELECT dial to choose “End,” then press the dial to return to the initial EZ Setup screen.

- * *Selecting “playback” and pressing the ENTER button plays back what you recorded.*
- * *Pressing “Try again” returns you to step 4 so you can record again.*

12

Press the EZ SETUP button to return to the normal screen.

MEMO

In the provided EZ Setup menus, depending on the selected item, the settings may be made using the normal setting screens. However, when you finish making all necessary settings, you are returned to the initial EZ Setup screen.

Cards Compatible with the AR-3000R

Types of Usable Cards

The AR-3000R stores recorded audio and MIDI signals on the card.

Also, all information other than recorded audio (phrase information) is stored on the card as well. (That is, it is not stored in the AR unit itself.)

This means that you can change the settings simply by swapping cards.

You can use the ARE-3000 AR Card Editor software to back up all of the data on memory cards using a Windows computer. When restoring backed up data to memory cards, be sure to use memory cards formatted with the AR.

- * Please download the ARE-3000 (free of charge) from the following URL.
<http://www.rssamerica.com>



Information cannot be stored in memory in the AR unit itself, so be sure to purchase cards separately. There are several types of card capacities available. The amount of information that you can store differs according to card capacity.



Depending on the type of CF card you are using, it may not be possible to perform recording or playback at the set RDAC-Grade and RDAC-Mode due to data write speed and other factors.

Card Storage Times and Number of Phrases

You can create up to 1,000 phrases on a single card.

When you format a card, you preselect 250, 500, or 1,000 as the maximum number of phrases to record on the card.

- * The possible recording time of a card varies according to card capacity and recording settings.
- * After formatting, you cannot change the maximum number of phrases. Please be aware that changing the maximum number of phrases requires reformatting, which erases everything stored on the card.
- * When you are using Card Conversion to convert a created card to AR-2000 format, select either 250 or 500 as the setting for the maximum number of phrases.



Depending on the length of stored phrases, it may not be possible to create the set maximum number of phrases.



For information about maximum recording times under various settings, refer to the "Card-specific Audio Recording Time Chart" in Appendices (p. 134).

Formatting a Card

Before you can use a new card, or a card that was formerly used on another device, you must first format (initialize) the card.

Once the formatting is complete, you can give the card a name (using up to eight characters). When you record a phrase, this card name is automatically added to the beginning of the phrase name.

Example: Card name: MESSAGE → Phrase name: MESSAGE 1

* If you don't give the card a name, the name "AR-3000" is used.

Important Note About Formatting

- Do not format cards on a computer.
- Formatting erases all data on the card. Before you format a card, make certain it does not contain any important data.
- You can create up to 1,000 phrases on a single card.

When you format a card, you preselect 250, 500, or 1,000 as the maximum number of phrases to record on the card.

- * The possible recording time of a card varies according to card capacity and recording settings.
- * After formatting, you cannot change the maximum number of phrases. Please be aware that changing the maximum number of phrases requires reformatting, which erases everything stored on the card.
- * When you are using Card Conversion to convert a created card to AR-2000 format, select either 250 or 500 as the setting for the maximum number of phrases.

Procedure for Formatting a Card

- 1 Make sure no CF cards are inserted into card slots A and B, then switch on the power.
- 2 Press the MODE button. The MODE indicator lights up.
- 3 Use the SELECT dial to choose "4.1 Card Format," then press the dial.
- 4 Insert the card you want to format into card slot A or B.



The time required for formatting also depends on the card type (capacity), and may take from several seconds to more than a minute.



In order to demonstrate the full performance of the AR-3000R, we recommend formatting for a maximum number of 1,000 phrases.



Depending on the length of stored phrases, it may not be possible to create the set maximum number of phrases.



For information about maximum recording times under various settings, refer to the "Card-specific Audio Recording Time Chart" in Appendices (p. 134).



For information about the initial values of various settings when formatted, refer to "Settings When a Card Is Formatted" (p. 135).



When you insert an unformatted card, an error message is displayed. Follow the on-screen instructions to format the card.

Cards Compatible with the AR-3000R

- 5** Turn the SELECT dial to choose the card you want to format (A or B), then press the dial.

```
4.1 Card Format      Card A
Select Max Phrase: 250
Card Size: 40MB
```

- 6** Turn the SELECT dial to choose the maximum number of phrases that can be recorded on the card (250, 500, or 1,000), then press the dial.

- 7** When the prompt appears on the screen, press the ENTER button to enable the settings.

To quit without making the settings, use the SELECT dial to choose "NO," then press the ENTER button.

NOTE

Never attempt to remove the card while formatting is in progress.

- 8** When formatting ends, enter the card name. Turn the SELECT dial to choose a character.

Press the dial to confirm the selected character.

```
4.1 Card Format      Card A
Card Name: ER-3000
Select Character: FWD
```

- **Characters you can use:** Letters of the alphabet (upper case) space numerals - ! # \$ % & ' () @ ^ _ { }
- **FWD:** This advances the location for entering a character. Pressing the dial advances the entry location by one.
- **BACK:** This moves back the location for entering a character. Pressing the dial moves back the entry location by one.
- **INS:** This inserts a space. Pressing the dial inserts a single space.
- **DEL:** This deletes a character. Pressing the dial deletes a single character.
- **END:** This quits the settings process.

- 9** To quit saving, in step 8, turn the SELECT dial to choose “END,” then press the dial.

```
4.1 Card Format      Card A
   Card Name:AR-3000
 Select Charactor: END
```

- 10** When the prompt appears on the screen, press the ENTER button to enable the settings.

To quit without making the settings, use the SELECT dial to choose “NO,” then press the ENTER button.

- When you’re finished making the setting, the display returns to the setting item selection screen.

- 11** Press the MODE button. This ends the setting process and returns you to the usual screen.

- * While making the settings, you can go back to the previous entry position (highlighted) by using the PAUSE (BACK) button.
- * If you press the MODE button while making settings, a message asking you to confirm that you want to exit the setting process appears. Note that if you choose “YES,” then press the ENTER button, you are returned to the usual screen, and all setting changes you’ve made up to that point will be discarded.

Important Notes on Handling Cards

●When Inserting

Securely insert the card as far as it will go into the card slot.

●When Removing

To remove a card, press the eject button.

Never attempt to remove a card while the card access indicator is illuminated.

Also, do not switch off the power or unplug the power cord while the card access indicator is illuminated. Doing so may damage the card.

- * Carefully insert the Memory card all the way in—until it is firmly in place.

Card Compatibility with Other Models in the AR Series

The AR-3000R's file format is the same as the format for the AR-3000/200/200S.

Using Cards Formatted on Earlier Model Units with the AR-3000R

- Compact Flash cards used with AR-3000/200/200Ss can be used as is with the AR-3000R.
- Files on PC cards used on AR-3000/200/2000/100 models can be used by copying the data to CompactFlash with the ARE-3000.
In addition, cards can be copied with the AR-3000 using a Compact Flash Card Adaptor (cards which have not been copied using ARE-3000 or an AR-3000 cannot be used).

Using Cards Formatted on the AR-3000R with Earlier Models

- Cards can be used as is with the AR-3000/200/200S.
- Cards can be used as is with the AR-3000/200 by copying the data to PC card (PM series) with the ARE-3000. (Use a Compact Flash Card Adaptor.)
- Cards cannot be used with the AR-2000/100.
(Cards copied using other AR models cannot be used.)

Please download the ARE-3000 (free of charge) from the following URL.
<http://www.rssamerica.com/>

The Display

Viewing the Basic Screen

Screen During Audio Phrase Playback

During normal audio phrase playback, the display shows the following information.

Stereo phrase

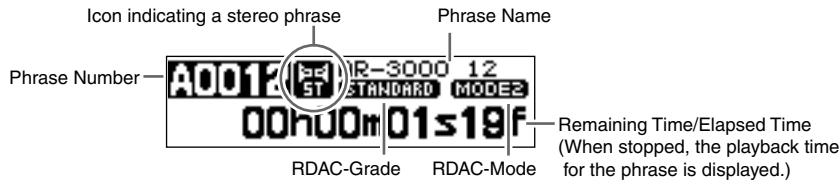

Mono phrase

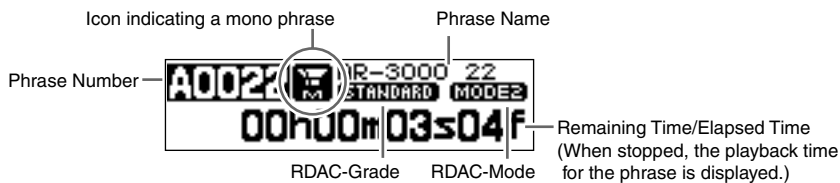

Screen During MIDI Phrase Playback

During MIDI phrase playback, the display shows the following information.

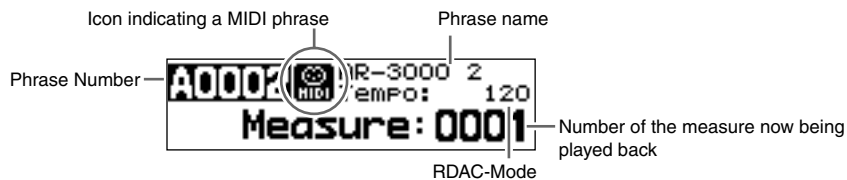

Screen During Pattern Phrase or Song Phrase Playback

During pattern phrase or song phrase playback, the display shows the following information.

Pattern phrase

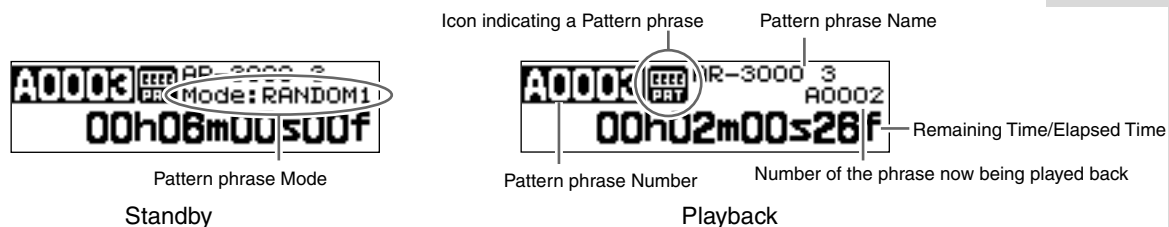

Song phrase

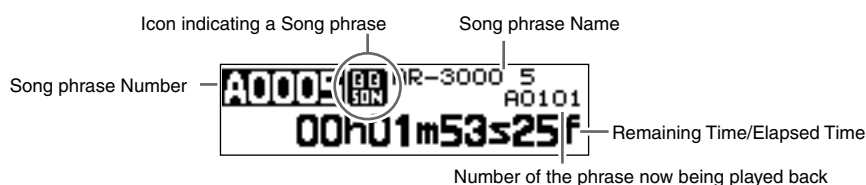

MEMO

You can the Elapsed Time/ Remaining Time display by pressing the ENTER button during playback or while playback is paused.



MIDI Phrases → p. 82



Pattern Phrases and Song Phrases → p. 62, p. 65

Viewing the 7-segment Display

The following information appears in the upper part of the display.

* Although seven-segment displays are shown in this manual, the actual device uses a dot matrix display.

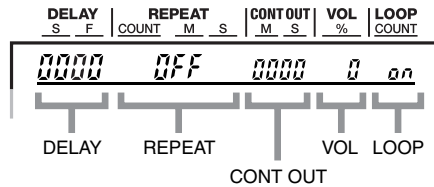

● DELAY (Delay Time)

When the “Delay Time” setting for a phrase during playback has been made, this shows the progress.

- This shows the time until playback starts (S: second, F: frame).
- When no delay has been set, “0000” is displayed.

● REPEAT

When the “Repeat Play” setting for a phrase during playback has been made, this shows the progress.

- This shows the setting for the number of repetitions.
- When the setting for the repeat interval has been made, this shows the time from when phrase playback ends until playback of the next phrase starts (M: minute, S: second).
- When Repeat Play is set to “On (Endless),” then “on” is displayed.
- When Repeat Play is set to “Off,” then “OFF” is displayed.

● CONT OUT (Control Out)

When the “Control Out” setting for a phrase during playback has been made, this shows the progress.

- This shows the offset time set for Control Out (the time after phrase playback until output—M: minute, S: second).
- When Control Out is set to “Off,” then “OFF” is displayed.

● VOL (Volume)

This displays the playback volume setting for audio phrases.

- For MIDI phrases, “---” is displayed.

● LOOP

When the “Loop Play” setting for a phrase during playback has been made, this shows the progress.

- This shows the setting for the number of loops.
- When the number of loops is set to “On (Endless),” then “on” is displayed.
- When the number of loops is set to “Off,” then “OFF” is displayed.
- For pattern phrases, song phrases, and MIDI phrases, “---” is displayed.



For items that do not function with AR-LINK, “---” is displayed.



Delay Time → p. 55



Repeat Play → p. 57



Control Out → p. 59



Play Volume → p. 54

Display-related Settings

Adjusting the Contrast

You can adjust the contrast of the display. Adjust it to match your usage conditions.

Procedure for Adjusting the Display Contrast

- 1** Press the MODE button.
The MODE indicator lights up.
- 2** Use the SELECT dial to choose “10.1 Contrast,” then press the dial.
- 3** Turn the SELECT dial to set Contrast (-10 to +10), then press the dial.

```
10 Configuration Setup
10.1 Contrast
    Contrast: 0
```

- 4** When the prompt appears on the screen, press the ENTER button to enable the settings.
To quit without making the settings, use the SELECT dial to choose “NO,” then press the ENTER button.
When you’re finished making the setting, the display returns to the setting item selection screen.

- 5** Press the MODE button. This ends the setting process and returns you to the usual screen.

* Pressing the MODE button while making the setting displays a prompt asking you whether you want to quit making the setting. Note that choosing “YES” and pressing the ENTER button returns you to the usual screen, discarding any settings made up to that point.

Making the Display Go Dark

You can make the display go dark automatically after a certain period of time has elapsed following the last operation in the phrase playback screen. You can set the time until the display goes dark (Sleep Time) to anything from 30 seconds to 59 minutes 59 seconds.

When the unit is in continuous use for long periods, such as on systems that run 24 hours a day, this can help protect the display from deterioration. Set it to match your usage conditions.

When the display is dark, the EZ SETUP indicator flashes.

When the display is dark, you can make it appear again quickly by pressing any of the six buttons on the front panel.

Procedure for Making the Display Go Dark

- 1** Press the MODE button.
The MODE indicator lights up.
- 2** Use the SELECT dial to choose "9.6 Display Sleep," then press the dial.
- 3** Turn the SELECT dial to choose Display Sleep (ON), then press the dial.
- 4** Turn the SELECT dial to make the setting for Sleep Time (00m 30sec to 59m 59sec), then press the dial.

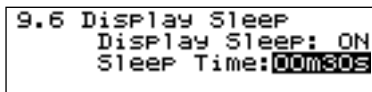

```
9.6 Display Sleep
Display Sleep: ON
Sleep Time: 00m30s
```

- 5** When the prompt appears on the screen, press the ENTER button to enable the settings.
To quit without making the settings, use the SELECT dial to choose "NO," then press the ENTER button.
When you're finished making the setting, the display returns to the setting item selection screen.

6

Press the MODE button. This ends the setting process and returns you to the usual screen.

- * While making the settings, you can go back to the previous entry position (highlighted) by using the PAUSE (BACK) button.
- * Pressing the MODE button while making the setting displays a prompt asking you whether you want to quit making the setting. Note that choosing "YES" and pressing the ENTER button returns you to the usual screen, discarding any settings made up to that point.

Making the Display Appear Again

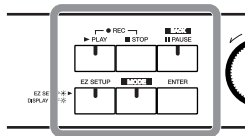

When the display is dark, you can make it appear again quickly by pressing any of the six buttons.

Recording Audio

Recording Units—Phrases

A single item of data recorded from the point where you start recording until the point where you stop recording is called a phrase. Audio data and MIDI data are both handled as phrases. Phrases are managed by phrase numbers.



MIDI Phrases → p. 82

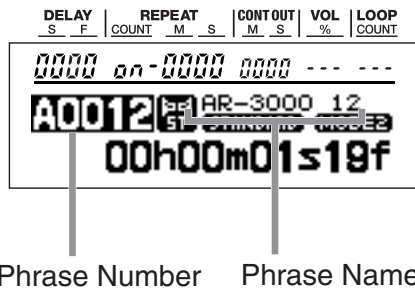

Connecting Equipment

The AR-3000R has a Mic jack on the front and an Analog Line In jack(LINE IN) and a Digital In jack(DIGITAL IN) on the back. Make the connections as appropriate for the equipment being used for recording.

You can also use the Mic jack and the Line In jack (analog only) at the same time. When you do this, it's possible to mix the Mic and Line In (analog) input.

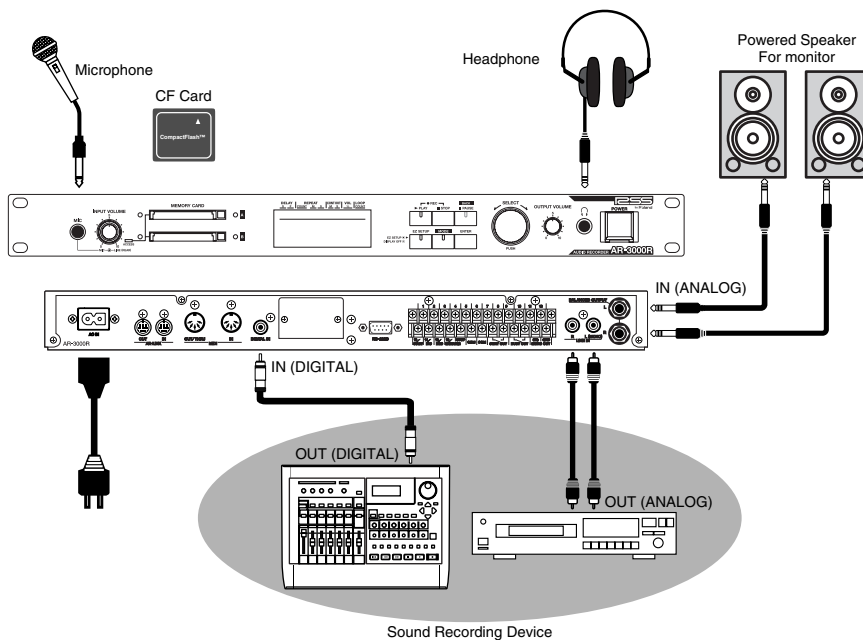

You cannot use the Mic and Digital In jacks at the same time.



To prevent malfunction and/or damage to speakers or other devices, always turn down the volume, and turn off the power on all devices before making any connections.

* Howling could be produced depending on the location of microphones relative to speakers. This can be remedied by:

1. Changing the orientation of the microphone(s).
2. Relocating microphone(s) at a greater distance from speakers.
3. Lowering volume levels.

Monitor Output During Recording and Recording Standby

Audio input from the **Mic jack and the Digital In jack** is output from the Balanced Output jacks, Headphone jack, and Mono Out port only during recording or recording standby, and you can monitor the recording state.

Audio input from the **Line In jacks** can be output from the Balanced Output jacks, Headphone jack, and Mono Out port during recording or recording standby, or even during ordinary playback.

* Audio input from the **Mic jack and the Digital In jack** cannot be output to the Balanced Output jacks, Headphone jack, and Mono Out port during playback.



The quality of sounds output from the audio output jack differs from that of RDAC-Grade or RDAC-Mode sound quality. Be sure to play back the phrase after recording to confirm the quality of the content.



Line Thru Settings → p. 125

Procedure for Recording

Important! Cards in AR-2000 format cannot be used.

If a card in AR-2000 format is inserted in either slot A or B (or both), the AR-3000R can be used only for playback, and it is not possible to record phrases or make any settings (except for card conversion and card format). Also, if you insert a card in AR-2000 format into slot A or B (or both) while making settings (except for card conversion and card format), the operation will halt with an error message. Thereafter, the operation cannot be resumed until all cards are removed. To record or edit cards in AR-2000 format on the AR-3000R, follow the steps in “Card Convert” (p. 78).

Enabling Recording Standby

Make the correct connections, then turn on the power switch.



Turning the Power On and Off → p. 24

Recording Standby

1

Insert a formatted card (p. 31) into one of the slots.

2

Turn the SELECT dial to choose the phrase number you want to record.

To switch between card slots A and B, press the SELECT dial.

* You cannot change the phrase number after recording, so be sure to select the phrase number you want to record.

3

Hold down the STOP button and press the PLAY button to go into recording standby.

During recording standby, the PLAY indicator and the PAUSE indicator flash in red.

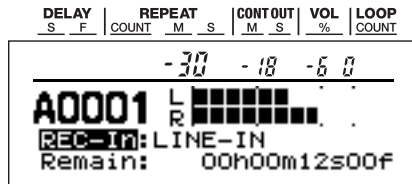

If you try to re-record a phrase that's already been recorded, a prompt message appears.

If you choose "YES" and press the Enter button, the recorded data for the phrase is deleted and the unit goes into recording standby. If you choose "NO," the unit returns to the normal display.

- * Please be aware that data deleted here cannot be recovered, even if you cancel recording standby without recording anything.
- * When Card Protect (p. 77) is set to "ON," recorded phrases are protected and recording is not possible (writing, overwriting, deleting, and editing card data is prohibited).

Required Settings for Recording Audio Signals (Recording Settings)

In order to perform recording matched to usage conditions, including the connected equipment, recording source, sound quality, time, and playback system, you make recording settings.

- Recording settings are made in phrase units. You can mix phrases having different recording settings on a single card.
- The possible recording time of a card varies according to the recording settings. For a rough guide to maximum recording times with various settings, see the "Card-specific Audio Recording Time Chart" in Appendices (p. 134).
- * When you don't change the recording settings, the recording settings for the most recent recording made on the specified card are used.
- * If you don't need to change the recording settings in effect when the card was formatted, you can proceed to "Adjusting the Recording Level" (p. 48).

Recording Settings in Effect When a Card Is Formatted

- REC-IN (Selected recording connector): LINE-IN
- RDAC-Grade: STANDARD
- RDAC-Mode: MODE3
- REC Type: STEREO
- Trig Level (Trigger recording setting): OFF

MEMO

When you have created a new phrase by re-recording, the following phrase information remains in effect and is not deleted.

- 1.1 Playback Volume (except MIDI Phrase)
- 1.2 Delay Time
- 1.4 Repeat Play
- 1.6 Fade (except MIDI Phrase)
- 1.7 Control Out
- 1.8 MIDI Tempo (only MIDI Phrase)
- 1.9 Phrase Name



Settings When a Card Is Formatted → p. 135

What's RDAC?

RDAC (Roland Digital Audio Coding) is a proprietary audio recording standard from Roland.

It achieves high sound quality and also makes it possible to record for long times.

REC-IN (Selecting the Recording Connector)

Set the input connector to record from. Make the selection to match the connected device.

- **LINE-IN:** LINE IN jacks
- **LINE+MIC-IN:** LINE IN jacks and Mic jack
- **DIGITAL-IN:** DIGITAL IN jack
- **MIDI-IN:** MIDI connector (In)

Procedure for Selecting the Recording Connector

- 1 Put the unit into recording standby.
- 2 Turn the SELECT dial to choose "REC-In."
- 3 Press the SELECT dial to advance the input location (highlighted).



- 4 Turn the SELECT dial to choose the REC-In (for audio recording, this is LINE-IN, LINE+MIC-IN or DIGITAL-IN), then press the ENTER button.



* Please be aware that if you press the SELECT dial instead of the ENTER button, the setting is not confirmed.

- Next, if you're making the setting for "RDAC-Grade" (p. 44), you can proceed to step 2 of the procedure for setting the RDAC-Grade.

NOTE

The "DIGITAL-IN" setting cannot be used when no device is connected to the DIGITAL IN jack

Recording Audio

RDAC-Grade (Sampling Frequency)

The RDAC-Grade is the type of sampling frequency for digital recording. On the AR-3000R, you can select from among six grades.

		Sound quality	Amount of card memory consumed
S-HIGH	: 48 kHz	High	Large
HIGH	: 44.1 kHz	↑	↑
STANDARD	: 32 kHz		
LONG1	: 22.05 kHz	↓	↓
LONG2	: 16 kHz		
ANNOUNCE	: 8 kHz	Small	

“S-HIGH” enables recording at the highest sound quality, but uses the most space on the card. “STANDARD” is best for ordinary recording.

“ANNOUNCE” uses up the least card space, and is best for recording announcements, narration, and the like. When you are recording audio such as a narration with “ANNOUNCE” or “LONG2,” you can record with higher clarity by using the equalizer (external device) to cut the bass range. Select an RDAC -Grade that matches the circumstances of use.

- If the type of card does not provide the recording time you want, change the RDAC-Mode or RDAC-Grade setting to use less card capacity, then perform recording again.
- Depending on the card type, an error may appear or recording may stop. If this happens, change the RDAC-Mode or RDAC-Grade setting to use less card capacity, then perform recording again.

Procedure for Setting the RDAC-Grade

- 1 Put the unit into recording standby.
- 2 Turn the SELECT dial to choose “RDAC-Grade,” then press the dial.

* You can set the RDAC-Grade only when you have selected “LINE-IN” or “LINE+MIC-IN” for the recording connector.



NOTE

The setting for the RDAC-Grade is made only for analog audio recording (selected connector: LINE-IN, LINE+MIC-IN). For digital recording, the setting is made automatically.



“Card-specific Recording Time Chart” → p. 134



“Error Messages” → p. 132

3

Turn the SELECT dial to choose RDAC-Grade (ANNOUNCE, LONG2, LONG1, STANDARD, HIGH, or S-HIGH), then press the ENTER button.



- * Pressing the PLAY button or the PAUSE button instead of the ENTER button starts recording without locking in the setting.
- * Please be aware that if you press the SELECT dial instead of the ENTER button, the setting is not confirmed.
 - The display of remaining time on the card available for recording changes according to the selected RDAC-Grade.
 - Next, if you're making the setting for "RDAC-Mode", you can proceed to step 2 of the procedure for setting the RDAC-Mode.

RDAC-Mode (Signal Processing System)

The RDAC-Mode is a type of digital data processing system for recording. On the AR-3000R, you can choose from among five types of modes.

		Sound quality	Amount of card memory consumed
H-LINEAR :	24 bit PCM Recording	High	Large
LINEAR :	16 bit PCM Recording	↑	↓
* 1 MODE3 :	About 2.5 times the recording of Linear		
MODE2 :	More than 2.5 times the recording of Linear		
MODE1 :	About 4 times the recording of Linear		

"H-LINEAR" enables recording at the highest sound quality, but uses the most space on the card. "MODE1" uses up the least card space, and is suited to long recording times. Select an RDAC-Mode that matches the circumstances of use.

- If the type of card does not provide the recording time you want, change the RDAC-Mode or RDAC-Grade setting to use less card capacity, then perform recording again.
- Depending on the card type, an error may appear or recording may stop. If this happens, change the RDAC-Mode or RDAC-Grade setting to use less card capacity, then perform recording again.



"Card-specific Recording Time Chart" → p. 134



"Error Messages" → p. 132

Recording Audio

* 1 Important Notes When Recording with MODE2 or MODE3

Recording times available when in MODE2 are about the same as in MODE3, or slightly longer. However, note that for phrases recorded in MODE2, you cannot make settings for some of the items in the phrase settings (Phrase Information (p. 54) and Phrase Editing (p. 67)).

<Unsettable Items for Phrases Recorded in MODE2>

●Phrase Information

- 1.3 Playback Point
- 1.5 Loop Play

●Phrase Editing

- 3.2 Phrase Truncate
- 3.4 Phrase Divide
- 3.5 Phrase Combine
- 3.6 Time Stretch

Procedure for Setting the RDAC-Mode

1 Put the unit into recording standby.

2 Turn the SELECT dial to choose "RDAC-Mode," then press the dial.



A0001 L R [Level Meter]
RDAC-Mode: MODE2
Remain: 00h00m12s00f

3 Turn the SELECT dial to choose the RDAC-Mode (MODE1, MODE2, MODE3, LINEAR, or H-LINEAR), then press the ENTER button.



A0001 L R [Level Meter]
RDAC-Mode: MODE2
Remain: 00h00m12s00f

* Pressing the PLAY button or the PAUSE button instead of the ENTER button starts recording without locking in the setting.

* Please be aware that if you press the SELECT dial instead of the ENTER button, the setting is not confirmed.

- The display of remaining time on the card available for recording changes according to the selected RDAC-Mode.
- Next, if you're making the setting for "REC Type", proceed to step 2 of the procedure for setting the recording type.

If You're Not Sure About Which Grade and Mode to Choose

The optimal grade and mode vary according to the usage conditions, including the connected equipment, recording source, sound quality, time, and playback system.

When a card is formatted, the RDAC-Grade is set to STANDARD and the RDAC-Mode is set to MODE3.

First, try recording and playback with these settings. In most cases, this yields satisfactory sound quality.

REC Type (STEREO or MONO)

Select either stereo recording or mono recording.

Choosing mono recording gives you recording times that are twice as long as with stereo recording.

Procedure for Setting the Recording Type

1 Put the unit into recording standby.

2 Turn the SELECT dial to choose "REC Type," then press the dial.



3 Turn the SELECT dial to choose the REC Type (STEREO or MONO), then press the ENTER button.



- * Pressing the PLAY button or the PAUSE button instead of the ENTER button starts recording without locking in the setting.
- * Please be aware that if you press the SELECT dial instead of the ENTER button, the setting is not confirmed.
- The display of remaining time on the card available for recording changes according to the selected recording settings.

Recording Audio

- Next, if you're making the setting for the "Trig Level", proceed to step 2 of the procedure for making the trigger recording setting.

Trig Level (Trigger Recording Settings)

A method for starting recording automatically when audio higher than the trigger level (the volume level for starting recording) is input is called trigger recording. The following four types of trigger recording settings are available.

- **OFF:** Trigger recording is not performed.
- **LOW:** Recording starts when audio at a low volume level is input (-45 dBm).
- **MID:** Recording starts when audio at an intermediate volume level is input (-36 dBm).
- **HIGH:** Recording starts when audio at a high volume level is input (-27 dBm).

(): Trigger level

* When you are recording from microphone input with the trigger level set at "LOW," recording may be inadvertently started by ambient noise. If this happens, change the trigger level to MID or HIGH, or carry out recording in a quieter location.

* If you quit recording without waiting for trigger recording to start, no phrase is created.

Procedure for the Trigger Recording Setting

1 Put the unit into recording standby.

2 Turn the SELECT dial to choose "Trig Level," then press the dial.



3 Turn the SELECT dial to choose the Trig Level (OFF, LOW, MID, or HIGH), then press the ENTER button.



* Please be aware that if you press the SELECT dial instead of the ENTER button, the setting is not confirmed.

Adjusting the Recording Level

Input audio from the connected device and adjust the recording level.

If the input volume level is too high, a symbol (OVER) like the one shown below appears on the display. If this happens, adjust the recording level by lowering the volume on the connected device or turning the Input Volume Knob on the unit so that the symbol does not appear.

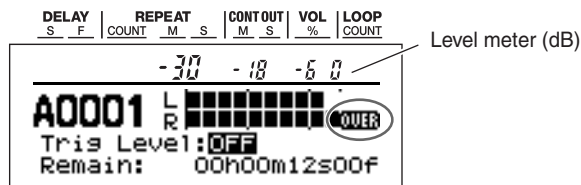

Starting and Ending Recording

1

When the unit is in recording standby, pressing the PLAY button or the PAUSE button starts recording.

During recording, the PLAY indicator lights up in red.

- When you have made the trigger recording setting, the unit waits for audio input higher than the trigger level (the volume level at which recording starts), then starts recording.

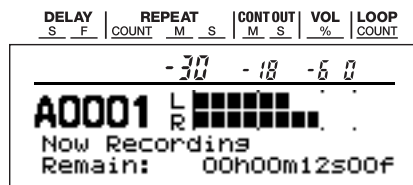

2

Press the STOP button to end recording.

- * You cannot change the phrase number afterward, so be sure select the phrase number you want to record before you start recording.
- * Recording cannot span two cards inserted in the slots. When the free space on one card is used up, recording ends automatically.

Starting and Stopping Recording with Control Input Terminals

You can start and stop recording using a control input terminals.

For information about making the settings, see "Assigning Phrases to Ports" for Direct playback (p. 88).

Checking What You Recorded

After recording ends, you can play back the phrase by pressing the PLAY button.

You can verify the phrase's RDAC-Grade, RDAC-Mode, recording type, and recording time by viewing the display.

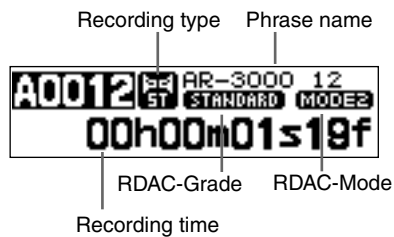

Information Recorded on the Card

The AR-3000R stores recorded audio and MIDI signals on the card.

It also stores all the setting information (such as MIDI settings) other than the unit's setting (Contrast) on the card.

This means you can switch all settings to the settings stored on a card simply by swapping cards.

Important Note: About Setting Information Imported from a Card

When you insert a card into slot, the unit imports setting information from the card. When a card is inserted in only one of the slots, the unit imports setting information from the card, but **note the following points when cards are inserted into both slot A and slot B.**

The Following Setting Information Is Imported from the Card in Slot A

- Control input settings
- MIDI settings
- RS-232C settings
- AR-LINK settings
- System settings

* Note that when the settings just described on cards in slots A and B are different, the settings just described on the card in slot B do not take effect.

The Following Setting Information Is Imported from Each Card

- Recording settings
- Phrase settings
- Settings for card editing

Playback Using the Panel on the Unit (Manual Playback)

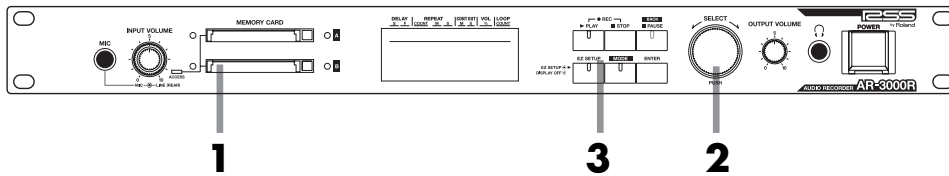

1 Insert a card containing recorded information into a slot.

2 Turn the SELECT dial to choose the phrase number to play. To switch between card slots A and B, press the SELECT dial.

3 Press the PLAY button to play the phrase.

During playback of the phrase, the PLAY indicator lights up in green.

- Pressing the PAUSE button pauses audio playback. While playback is paused, the PLAY (green) and PAUSE (green) indicators flash. To resume playback, press either the PLAY or the PAUSE button.
- Pressing the STOP button ends playback.
- During playback, you can choose the next song to play (without stopping the phrase being played) by turning the SELECT dial.

Note that playback cannot be paused in the following cases:

- MIDI phrase (→ p. 82)
- Pattern phrase (→ p. 62)
- Song phrase (→ p. 65)
- Dual Mono mode (ON) (→ p. 120)

Playback Location Search

While paused, you can move the present phrase location forward or backward by turning the SELECT dial.

To switch the unit of change, press the SELECT dial. (The units cycle through the sequence of frame → second → minute → hour.)

Pressing the PLAY or PAUSE button again starts playback at the specified location.

NOTE

Playback cannot be paused during crossfades, repeats, or intervals.

NOTE

Playback of audio phrases whose RDAC-Mode is MODE2 cannot be paused.

Playback Using the Panel on the Unit

Time Shown on the Display

During playback or while playback is paused, you switch the time shown on the display between “Remaining Time (REMAIN)” and “Elapsed Time” by pressing the ENTER button.

Elapsed Time



Remaining Time



This shows that it is the remaining time.

AUDIO RECORDER AR-3000R

Applications

Modifying Recorded Phrases (Phrase Settings)

Adding Information to Individual Phrases (Phrase Information)

This adds a variety of information to recorded phrases (phrase information).

If you want the phrase information when the card was formatted to remain unchanged, then you don't need to change any settings.



Settings When a Card Is Formatted → p. 135

MEMO

To check phrases during various settings, you can play back and stop phrases using the PLAY and STOP buttons (audio phrases only). Note that you cannot change settings during phrase playback.

NOTE

The items that can be set differ according to the type of phrase (audio phrase, MIDI phrase, pattern phrase, or song phrase). Also refer to the Phrase Information/Phrase Setting Correspondence Table (p. 75).

NOTE

If a card in AR-2000 format is inserted in either slot A or B (or both), the AR-3000R can be used only for playback, and it is not possible to record phrases or make any settings (except for card conversion). Also, if you insert a card in AR-2000 format into slot A or B (or both) while making settings (except for card conversion), operation will halt with an error message, and cannot be resumed until such cards are removed. To record or edit cards in AR-2000 format on the AR-3000R, follow the steps in "Card Convert" (p. 78).

Three Useful Playback Modes for Phrase Settings

The AR-3000R offers three playback modes that you can use during phrase settings that let you make point settings and the like, and check settings smoothly.

* The playback modes that you can select vary according to the setting items.

PLAY: This is the mode for normal playback. It plays back the entire phrase. Use it to check what a phrase includes.

PREVIEW: This mode plays back phrases with the settings in effect. Playback is conducted for a fixed time according to the setting items.

SCRUB: This mode performs loop play (scrub play) of a desired short passage (about 45 msec) in a phrase. During playback, you can move the playback passage by turning the

SELECT dial. Use this to set a precise point for the playback point or the like.

Procedure

1. At the various phrase setting screens, press the PLAY button when making settings such as phrase selections or playback points.

A menu (window) for selecting the playback mode appears.



* If PLAY is the only selected mode, phrase playback starts at this time.

2. Turn the SELECT dial to choose the playback mode.
3. Press the PLAY button.

Playback starts, in the selected mode.

* If you selected SCRUB, you can move the playback passage during playback by turning the SELECT dial. You can move the cursor (highlighting) by pressing the BACK button and the SELECT dial.



Approximate guide to the location of the points for the entire phrase.

4. Pressing the STOP button ends playback.

NOTE

Depending on the location of the cursor on the screen, the playback mode may not be enabled.

Play Volume (%)

This sets the volume level during playback of audio phrases. The volume level at the time of recording is considered to be 100%.

Procedure for Setting the Play Volume

1. Use the SELECT dial to choose the phrase whose setting you want to change.
2. Press the MODE button.
The MODE indicator lights up.
3. Use the SELECT dial to choose "1.1 Play Volume," then press the dial.

You can reselect a phrase whose setting you want to change by pressing the PAUSE (BACK) button. The entry position (highlighted) moves to the phrase selection, so turn the SELECT dial to reselect card A or B and the phrase number, then press the dial.

- Turn the SELECT dial to set the Volume (from 10% to 100%), then press the dial.

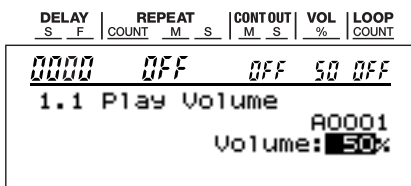

You can play back the selected phrase by pressing the PLAY button. This makes it possible to make the setting while monitoring the actual volume level.



You can change the selected phrase by pressing the BACK button and moving the cursor to the phrase number.

- When the prompt appears on the screen, press the ENTER button to enable the settings.

To quit without making the settings, use the SELECT dial to choose "NO," then press the ENTER button.

Once the settings have been successfully modified, you're returned to the setting item selection screen.

- Press the MODE button.

This ends the setting process and returns you to the usual screen.

* If you press the MODE button while making settings, a message asking you to confirm that you want to exit the setting process appears. Note that if you choose "YES," then press the ENTER button, you are returned to the usual screen, and all setting changes you've made up to that point will be discarded.

Delay Time (00s 00f to 59s 29f)

This sets the time until phrase playback starts.

* The frame display varies according to the setting for the MIDI Time Code (MTC) frame rate.

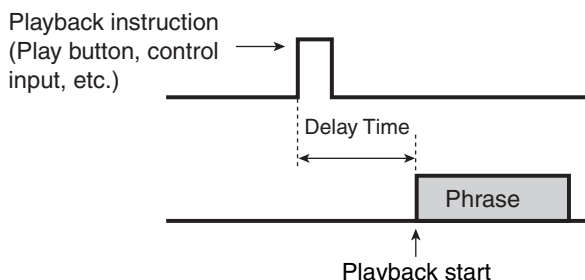

If you're using Busy Out signals to start an amp or the like, inserting a delay time into the phrase that corresponds to the amp start time (that is, the time until sound is produced) can help prevent drop-out

at the beginning of the phrase at the time of playback.



Busy Out → p. 102

Procedure for Setting the Delay Time

- Use the SELECT dial to choose the phrase whose setting you want to change.
- Press the MODE button.
The MODE indicator lights up.
- Use the SELECT dial to choose "1.2 Delay Time," then press the dial.

You can reselect a phrase whose setting you want to change by pressing the PAUSE (BACK) button. The entry position (highlighted) moves to the phrase selection, so turn the SELECT dial to reselect card A or B and the phrase number, then press the dial.

- Turn the SELECT dial to set the Delay Time, then press the dial.

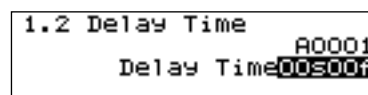

- When the prompt appears on the screen, press the ENTER button to enable the settings.

To quit without making the settings, use the SELECT dial to choose "NO," then press the ENTER button.

Once the settings have been successfully modified, you're returned to the setting item selection screen.

- Press the MODE button.

This ends the setting process and returns you to the usual screen.

* If you press the MODE button while making settings, a message asking you to confirm that you want to exit the setting process appears. Note that if you choose "YES," then press the ENTER button, you are returned to the usual screen, and all setting changes you've made up to that point will be discarded.

Playback Point (Start and End)

These determine where phrase playback is to start and end.

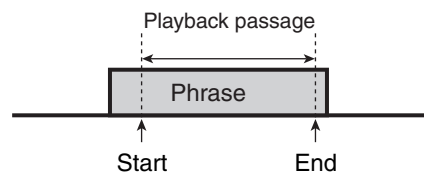

* You can automatically seek and set points at the locations of silent portions (AUTO).

Modifying Recorded Phrases (Phrase Settings)

Levels of -45 dBm or lower are treated as silent.

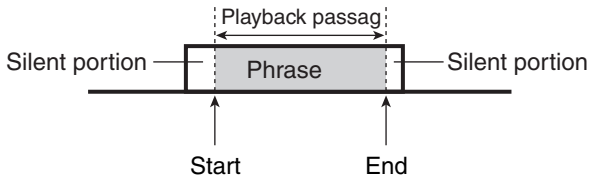

HINT

You can use the phrase-editing Truncate function (p. 67) to delete data outside the set points.

NOTE

You cannot make these settings for MODE2 phrases.

Procedure for Setting Playback Point

1. Use the SELECT dial to choose the phrase whose setting you want to change.
2. Press the MODE button.
The MODE indicator lights up.
3. Use the SELECT dial to choose "1.3 Playback Point," then press the dial.

You can reselect the phrase whose setting you want to change by pressing the PAUSE (BACK) button. The entry position (highlighted) moves to the phrase selection, so turn the SELECT dial to reselect card A or B and the phrase number, then press the dial.

When Making the Settings Manually

4. Turn the SELECT dial to choose MANUAL as the playback-point setting method, then press the dial.

```
1.3 PlaybackPointA0001
Settings Mode: MANUAL
Start: 00h00m00s00f0sf
End: 00h00m00s00f0sf
```

Turn the SELECT dial to set the start position (time), then press the dial.

* Each press of the BACK button moves the cursor (highlighted) in the sequence of sf → f → s → m → h. Pressing the dial while the cursor (highlighting) is at the "sf" position moves the end position setting.

* The frame display varies according to the setting for the MIDI Time Code (MTC) frame rate.

Turn the SELECT dial to set the end position (time), then press the dial.

HINT

While setting the points, you can set the points while listening to the audio by using the SCRUB playback mode (p. 54).

5. When the prompt appears on the screen, press the ENTER button to enable the settings.

To quit without making the settings, use the SELECT dial to choose "NO," then press the ENTER button.

Once the settings have been successfully modified, you're returned to the setting item selection screen.

6. Press the MODE button.

This ends the setting process and returns you to the usual screen.

- * While making the settings, you can go back to the previous entry location (highlighted) by pressing the PAUSE (BACK) button.
- * If you press the MODE button while making settings, a message asking you to confirm that you want to exit the setting process appears. Note that if you choose "YES," then press the ENTER button, you are returned to the usual screen, and all setting changes you've made up to that point will be discarded.

When Making the Settings Automatically

7. Turn the SELECT dial to choose Auto as the playback-point setting method, then press the dial.

```
1.3 PlaybackPointA0001
Settings Mode: AUTO
Start: 00h00m00s00f0sf
End: 00h00m00s00f0sf
```

The start and end locations are set automatically.

```
1.3 PlaybackPointA0001
Settings Mode: AUTO
Start: 00h00m01s00f0sf
End: 00h00m12s20f0sf
```

HINT

You can make fine adjustments in the set points by pressing the PAUSE (BACK) button, moving the entry position (highlighted) to the start or end location, and using the SCRUB playback mode (p. 54).

8. When the prompt appears on the screen, press the ENTER button to enable the settings.

To quit without making the settings, use the SELECT dial to choose "NO," then press the ENTER button.

Once the settings have been successfully modified, you're returned to the setting item selection screen.

9. Press the MODE button.

This ends the setting process and returns you to the usual screen.

- * While making the settings, you can go back to the previous entry location (highlighted) by pressing the PAUSE (BACK) button.

* If you press the MODE button while making settings, a message asking you to confirm that you want to exit the setting process appears. Note that if you choose "YES," then press the ENTER button, you are returned to the usual screen, and all setting changes you've made up to that point will be discarded.

Repeat Play (Repeat, Repeat Interval)

This makes the settings for repeated playback of a phrase.

Repeat passage: This is the passage set with the playback points (described earlier).

Repeat: This sets the number of times playback is repeated. (For example, when the number of repetitions is set to five times, the phrase is played back a total of six times.) When the number of repetitions is set to ON, playback repeats endlessly.

Repeat Interval: This sets the playback interval as a time value.

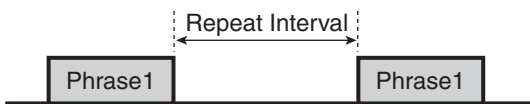

Procedure for Making Repeat Play Settings

1. Use the SELECT dial to choose the phrase whose setting you want to change.

2. Press the MODE button.
The MODE indicator lights up.

3. Use the SELECT dial to choose "1.4 Repeat Play," then press the dial.

You can reselect a phrase whose setting you want to change by pressing the PAUSE (BACK) button. The entry position (highlighted) moves to the phrase selection, so turn the SELECT dial to reselect card A or B and the phrase number, then press the dial.

4. Turn the SELECT dial to choose Repeat (OFF/ON/1 to 99), then press the dial.

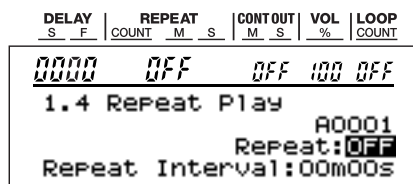

Turn the SELECT dial to set the Repeat Interval (from 00 m 00 s to 59 m 59 s), then press the dial.

* The number of the repeat interval can be set only when repeat "ON" or "1-99" is selected.

5. When the prompt appears on the screen, press the ENTER button to enable the settings.

To quit without making the settings, use the SELECT dial to choose "NO," then press the ENTER button.

Once the settings have been successfully modified, you're returned to the setting item selection screen.

6. Press the MODE button.

This ends the setting process and returns you to the usual screen.

* While making the settings, you can go back to the previous entry location (highlighted) by pressing the PAUSE (BACK) button.

* If you press the MODE button while making settings, a message asking you to confirm that you want to exit the setting process appears. Note that if you choose "YES," then press the ENTER button, you are returned to the usual screen, and all setting changes you've made up to that point will be discarded.

Loop Play (Loop, Loop 1, Loop 2, Crossfade Time)

This makes the setting for loop playback of the desired passage of a phrase. Loop Playback starts at the start point (playback point), then after looping the specified number of times, playback ends at the end point (playback point).

Loop: This sets the number of times playback is looped. (For example, when the number of loops is set to five times, the looped phrase is played back a total of six times.) When the number of loops is set to Endless, playback loops endlessly.

Loop 1: This specifies the return point for looping.

Loop 2: This specifies the repeat point for looping.

Crossfade Time: This adjusts the junction during loop playback. Longer times make for progressively greater smoothness.

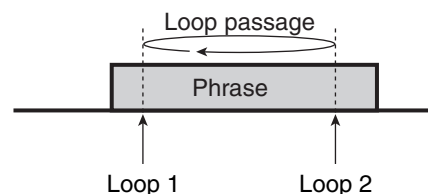

Loop Play is not possible when in the Dual Mono mode.



You cannot make these settings for MODE2 phrases.



When the number of loops is set to Endless, playback stops approximately 50 days after the loop begins.

Modifying Recorded Phrases (Phrase Settings)

Procedure for Making Loop Play Settings

1. Use the SELECT dial to choose the phrase whose setting you want to change.

2. Press the MODE button.

The MODE indicator lights up.

3. Use the SELECT dial to choose "1.5 Loop Play," then press the dial.

You can reselect a phrase whose setting you want to change by pressing the PAUSE (BACK) button. The entry position (highlighted) moves to the phrase selection, so turn the SELECT dial to reselect card A or B and the phrase number, then press the dial.

4. Turn the SELECT dial to choose Loop (OFF/ON/1 to 99), then press the dial.

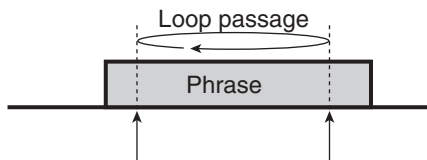

Turn the SELECT dial to set the Loop 1 position (time), then press the dial. Pressing the dial while the cursor (highlighting) is at the "sf" position moves the Loop 2 position setting.

* The time that is set is shown as a relative amount of time, with the start position of the playback point taken to be 0.

* Each press of the BACK button moves the cursor (highlighted) in the sequence of sf → f → s → m → h.

Turn the SELECT dial to set the Loop 2 position (time), then press the dial.

* The looped region cannot be set to value less than 10 frames.

HINT

You can set the points while listening to the audio by using the SCRUB playback mode (Owner's Manual p. 54). You can check the Loop 1 and Loop 2 junctures using the Preview playback mode.

5. Turn the SELECT dial, select the Crossfade Time (0 ms to 1000 ms), then press the dial.

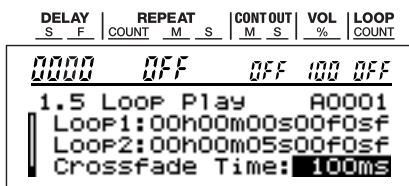

6. When the prompt appears on the screen, press the ENTER button to enable the settings.

To quit without making the settings, use the SELECT dial to choose "NO," then press the ENTER button.

Once the settings have been successfully modified, you're

returned to the setting item selection screen.

7. Press the MODE button.

This ends the setting process and returns you to the usual screen.

* While making the settings, you can go back to the previous entry location (highlighted) by pressing the PAUSE (BACK) button.

* If you press the MODE button while making settings, a message asking you to confirm that you want to exit the setting process appears. Note that if you choose "YES," then press the ENTER button, you are returned to the usual screen, and all setting changes you've made up to that point will be discarded.

MEMO

If a start or end playback point is set within the looped interval, the start point is set to Loop 1 and the end point is set to Loop 2.

Fade (Fade In and Fade Out)

This makes the settings for starting phrase playback with a Fade In and ending playback with a Fade Out.

This sets the time until the playback level is reached from silence (Fade In) and the time until silence is reached from the playback level (Fade Out).

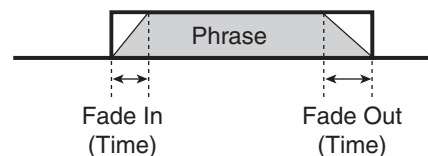

HINT

If there is noise or the like at the beginning or end of a phrase, you can cause the noise component not to be played back simply by setting the Fade In or Fade Out times to Time 1 through Time 3.

Time1: Set at approx. 10 msec.

Time2: Set at approx. 30 msec.

Time3: Set at approx. 50 msec.

Removal effect when noise or the like is present

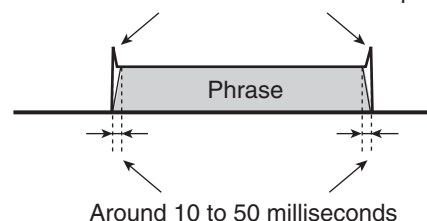

HINT

Setting the Fade In or Fade Out time to about 5 seconds is an effective way to produce a normal Fade In (crescendo), or Fade Out (decrecendo) effect.

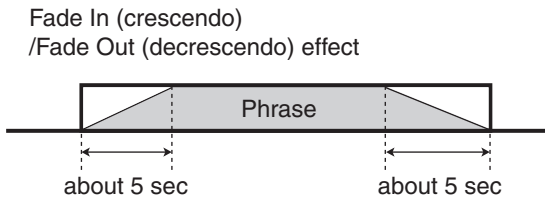

MEMO

When you use the Stop button (or other means) to stop a phrase during playback for which this setting has been made, the phrase stops with a Fade Out. If you don't want a Fade Out, pressing the Stop button again stops the phrase immediately.

Procedure for Making the Settings for Fade In or Fade Out

1. Use the SELECT dial to choose the phrase whose setting you want to change.
2. Press the MODE button.
The MODE indicator lights up.
3. Use the SELECT dial to choose "1.6 Fade," then press the dial.

You can reselect a phrase whose setting you want to change by pressing the PAUSE (BACK) button. The entry position (highlighted) moves to the phrase selection, so turn the SELECT dial to reselect card A or B and the phrase number, then press the dial.

4. Turn the SELECT dial to make the setting for Fade In (time: OFF, Time 1 to Time 3, or from 00.1 to 59.9 seconds), then press the dial.

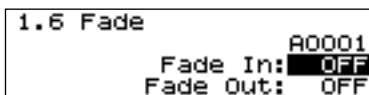

Turn the SELECT dial to make the setting for Fade Out (time: OFF, Time 1 to Time 3, or from 00.1 to 59.9 seconds), then press the dial.

5. When the prompt appears on the screen, press the ENTER button to enable the settings.

To quit without making the setting, use the SELECT dial to choose "NO," then press the ENTER button.

Once the settings have been successfully modified, you're returned to the setting item selection screen.

6. Press the MODE button.

This ends the setting process and returns you to the usual

screen.

- * While making the settings, you can go back to the previous entry location (highlighted) by pressing the PAUSE (BACK) button.
- * If you press the MODE button while making settings, a message asking you to confirm that you want to exit the setting process appears. Note that if you choose "YES," then press the ENTER button, you are returned to the usual screen, and all setting changes you've made up to that point will be discarded.

NOTE

Fade settings may not be properly reflected in situations such as the following:

- When the set fade time is longer than the phrase.
- When fade-in and fade-out settings overlap.
- When loop-interval settings and fade settings overlap.

Control Out

This makes the setting for Control Out operation after phrase playback ends.



For detailed information on how to use Control Out, refer to "Controlling Another Device with the AR-3000R (Control Output Terminal)" (p. 102).

Procedure for Making the Control Out Settings

1. Use the SELECT dial to choose the phrase whose setting you want to change.
2. Press the MODE button.
The MODE indicator lights up.
3. Use the SELECT dial to choose "1.7 Control Out," then press the dial.

You can reselect a phrase whose setting you want to change by pressing the PAUSE (BACK) button. The entry position (highlighted) moves to the phrase selection, so turn the SELECT dial to reselect card A or B and the phrase number, then press the dial.

4. Turn the SELECT dial to choose Control Out (OFF or ON), then press the dial.

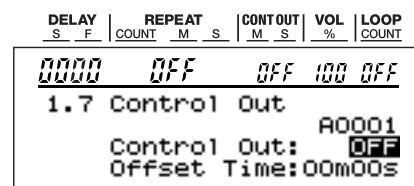

Turn the SELECT dial to set the Offset Time (from 00m00s to 59m59s), then press the dial.

Modifying Recorded Phrases (Phrase Settings)

* The offset time can be set only when Control Out "ON" is selected.

5. When the prompt appears on the screen, press the ENTER button to enable the settings.

To quit without making the settings, use the SELECT dial to choose "NO," then press the ENTER button.

Once the settings have been successfully modified, you're returned to the setting item selection screen.

6. Press the MODE button.

This ends the setting process and returns you to the usual screen.

* While making the settings, you can go back to the previous entry location (highlighted) by pressing the PAUSE (BACK) button.

* If you press the MODE button while making settings, a message asking you to confirm that you want to exit the setting process appears. Note that if you choose "YES," then press the ENTER button, you are returned to the usual screen, and all setting changes you've made up to that point will be discarded.

Changing the Playback Tempo for MIDI Phrases (MIDI Playback Tempo)

This changes the playback tempo for MIDI phrases.



For detailed information about how to use MIDI phrases, refer to the chapter "Recording and Playing MIDI Phrases" (p. 82).

Procedure for Setting the MIDI Tempo

1. Use the SELECT dial to choose the phrase whose setting you want to change.

2. Press the MODE button.

The MODE indicator lights up.

3. Use the SELECT dial to choose "1.8 MIDI Tempo," then press the dial.

You can reselect a phrase whose setting you want to change by pressing the PAUSE (BACK) button. The entry position (highlighted) moves to the phrase selection, so turn the SELECT dial to reselect card A or B and the phrase number, then press the dial.

4. Turn the SELECT dial to set the MIDI tempo (from 5 to 260), then press the dial.

```
1.8 MIDI Tempo      A0002
                    Tempo: 100
Original Tempo: [120]
```



You can play back the selected phrase by pressing the PLAY button. This makes it possible to make the setting while monitoring the actual tempo.

5. When the prompt appears on the screen, press the ENTER button to enable the settings.

To quit without making the settings, use the SELECT dial to choose "NO," then press the ENTER button.

Once the settings have been successfully modified, you're returned to the setting item selection screen.

6. Press the MODE button.

This ends the setting process and returns you to the usual screen.

* If you press the MODE button while making settings, a message asking you to confirm that you want to exit the setting process appears. Note that if you choose "YES," then press the ENTER button, you are returned to the usual screen, and all setting changes you've made up to that point will be discarded.

Phrase Name

This assigns a name to a phrase. You can enter a phrase name of up to 12 characters. (For a phrase that has already been recorded, the phrase name is the card name plus the phrase number.)

Procedure for Setting the Phrase Name

1. Use the SELECT dial to choose the phrase whose setting you want to change.

2. Press the MODE button.

The MODE indicator lights up.

3. Use the SELECT dial to choose "1.9 Phrase Name," then press the dial.

You can reselect a phrase whose setting you want to change by pressing the PAUSE (BACK) button. The entry position (highlighted) moves to the phrase selection, so turn the SELECT dial to reselect card A or B and the phrase number, then press the dial.

4. Turn the SELECT dial to choose a character. Press the dial to confirm the selected character.

```
1.9 Phrase Name      A0002
                    Name: [R-3000 2]
Select Character: FWD
```

Characters you can use: Letters of the alphabet (upper case) space numerals ! # \$ % & ' () @ ^ _ { }

FWD: This advances the location for entering a character.

Pressing the dial advances the entry location by one.

BACK: This moves back the location for entering a character. Pressing the dial moves back the entry location by one.

INS: This inserts a space. Pressing the dial inserts a single space.

DEL: This deletes a character. Pressing the dial deletes a single character.

END: To finish the process.

5. To finish the save process, then in step 4, turn the SELECT dial to choose End, then press the dial.

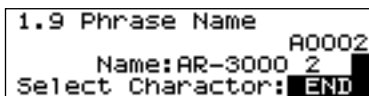

```
1.9 Phrase Name      A0002
Name: AR-3000 2
Select Charactor: END
```

6. When the prompt appears on the screen, press the ENTER button to enable the settings.

To quit without making the settings, use the SELECT dial to choose "NO," then press the ENTER button.

Once the settings have been successfully modified, you're returned to the setting item selection screen.

7. Press the MODE button.

This ends the setting process and returns you to the usual screen.

- * While making the settings, you can go back to the previous entry location (highlighted) by pressing the PAUSE (BACK) button.
- * If you press the MODE button while making settings, a message asking you to confirm that you want to exit the setting process appears. Note that if you choose "YES," then press the ENTER button, you are returned to the usual screen, and all setting changes you've made up to that point will be discarded.

Modifying Recorded Phrases (Phrase Settings)

Creating Combinations of Phrases (Phrase Combination)

You can create new phrases by combining a number of phrases already recorded and storing the result as a different phrase. There are two types of methods for creating phrase combinations: pattern phrases and song phrases.

MEMO

To check phrases during various settings, you can play back and stop phrases using the PLAY and STOP buttons (audio phrases or MIDI phrases). Note that you cannot change settings during phrase playback. → (p. 54)

NOTE

If a card in AR-2000 format is inserted in either slot A or B (or both), the AR-3000R can be used only for playback, and it is not possible to record phrases or make any settings (except for card conversion). Also, if you insert a card in AR-2000 format into slot A or B (or both) while making settings (except for card conversion), operation will halt with an error message, and cannot be resumed until such cards are removed. To record or edit cards in AR-2000 format on the AR-3000R, follow the steps in "Card Convert" (p. 78).

Combinations of Phrase Units (Pattern Phrases)

You can combine a number of phrases to create a new phrase (pattern phrase). A pattern phrase is a stored combination of phrases that have already been recorded. A pattern phrase is also treated as a single phrase.

Creating pattern phrases makes it possible to create and start a variety of combined-phrase patterns while saving card memory space.

Specific Examples

First, make actual recordings of three phrases like the ones described below.

A0001: "Thank you for coming"

A0002: "Today"

A0003: "Despite the bad weather"

Combine these three to create a pattern phrase.

Actual phrase A0001

Thank you for coming

Actual phrase A0002

Today

Actual phrase A0003



Despite the bad weather

Pattern Phrase A0004

A0001 : A0002

Pattern Phrase A0005

A0001 : A0002 : A0003

 : Single Phrase
 : Pattern Phrase

A0004: "Thank you for coming today" (for sunny days)

A0005: "Thank you for coming today, despite the bad weather." (for rainy days)

Set A0004 or A0005 to start on playback.

Phrases 0001 through 0005 are used, but the phrases actually recorded (the actual phrases) are only 0001, 0002, and 0003.

- You can assign up to 100 phrases to a single pattern phrase.
- You can set the phrase playback sequence (pattern phrase mode) to SEQ or to RANDOM 1, 2, or 3.



About Pattern Phrase Playback Methods (Pattern Phrase Modes) → p. 63

- The playback volume level for phrases is set at 100% of the volume level when recorded. (The overall volume level for each pattern phrase is set with phrase information 1.1 Play Volume.)

* This setting cannot be made for MIDI phrases.

- The interval sets the time between playback of one phrase and the next phrase.

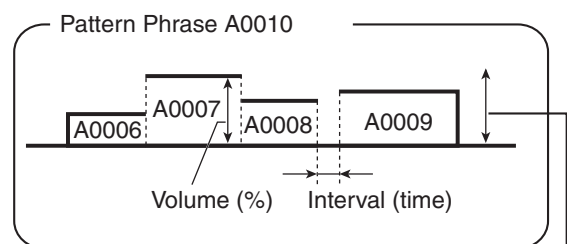

Playback volume for the entire pattern phrase (A0010)
 (Phrase Information 1.1 Play Volume)

- You can assign a phrase any number of times to a single pattern phrase, or to more than one pattern phrase.
- You can assign pattern phrases that have already been created to other pattern phrases.

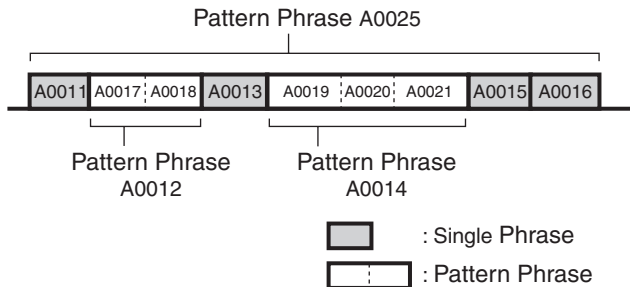

* When a hierarchy of two or more levels of pattern phrases is assigned, playback may not be correct.

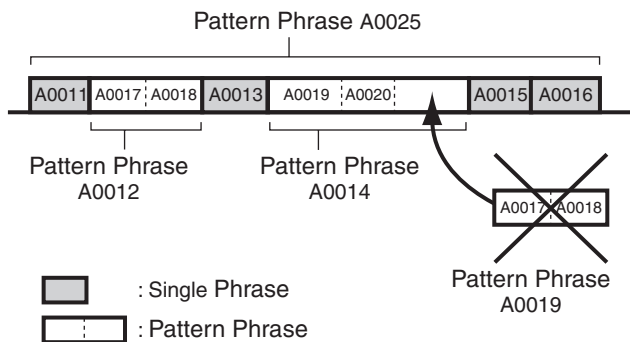

- You can also assign MIDI phrases to pattern phrases.
- You can assign a mixture of audio phrases and MIDI phrases.
- Song phrases that have already been created (p. 65) cannot be assigned to pattern phrases.

NOTE

“Playback Volume”, “Playback Point” and “Fade settings” included in the phrase information for phrases assigned to a pattern phrase remain in effect, but other phrase information is disregarded. Because the volume level set for a phrase alone is disregarded, to adjust the volume, adjust the volume setting for the pattern phrase.

NOTE

- When you are creating a pattern phrase, you can choose actual phrases from both card A and card B, but note that the pattern phrase is not played back correctly if the card containing the constituent phrase is not inserted at the time of playback. (If a constituent phrase does not exist, the unit seeks and plays back the next phrase.)

About Pattern Phrase Playback Methods (Pattern Phrase Modes)

There are four types of pattern-phrase playback methods (pattern phrase modes), which are described below. Choose the one that matches your usage conditions.

SEQ: This plays back the phrases in the sequence in which they were assigned.

RANDOM1: This plays back the phrases assigned to No. 001 through No. 100 at random.

RANDOM2: This plays back the phrases assigned to No. 001 through No. 100 at random, while allowing you to insert another phrase once at a set number of times (interrupt phrase interval of 1 to 25). The interrupt phrase is selected sequentially from phrases No. 101 through 128.

RANDOM3: This plays back the phrases assigned to No. 001 through No. 100 at random, while allowing you to insert another phrase once at a set number of times (interrupt phrase interval of 1 to 25). The interrupt phrase is selected randomly from phrases No. 101 through 128.

NOTE

Assign only audio phrases to Nos. 101 through 128.

SEQ

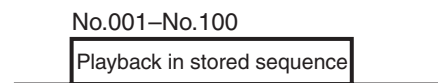

RANDOM1

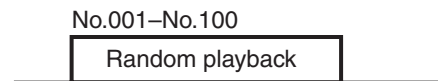

RANDOM2

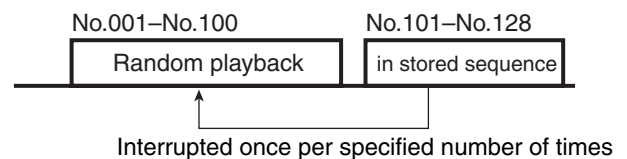

RANDOM3

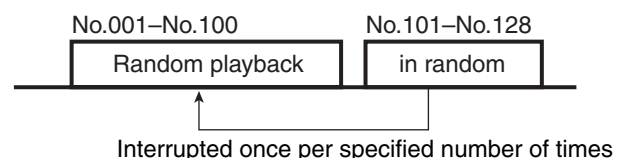

* With random playback, once a phrase has been played back it is not chosen again.

Procedure for Creating a Pattern Phrase

1. Press the MODE button.

The MODE indicator lights up.

2. Use the SELECT dial to choose “2.1 Pattern Phrase,” then press the dial.

Modifying Recorded Phrases (Phrase Settings)

3. Turn the SELECT dial to choose the card containing an empty phrase for creating a new pattern phrase or the pattern phrase whose settings you want to change, then press the dial.
4. Turn the SELECT dial to choose the empty phrase for creating a new pattern phrase or the pattern phrase whose settings you want to change, then press the dial.
 - * Only phrases that can be executed are displayed.
5. Turn the SELECT dial to choose the pattern phrase mode (SEQ, RANDOM1, RANDOM2, or RANDOM3), then press the dial.

```
2.1 Pattern Phr. A0005
Mode:SEQ
No001 ----- % --.s
Total[00h00m00s00f]
```

- * The interrupt phrase interval described below can be set only when you have selected RANDOM2 or RANDOM3. If you selected SEQ or RANDOM1, proceed to step 7.
6. Turn the SELECT dial to set the interrupt phrase interval (from 1 to 25), then press the dial.

```
2.1 Pattern Phr. A0005
Mode:RANDOM2 Int:0
No001 ----- % --.s
Total[00h00m00s00f]
```

7. Turn the SELECT dial to choose the playback sequence, then press the dial.
 - If you selected SEQ or RANDOM1, assign phrases in playback order No. 001 through No. 100.
 - If you selected RANDOM2 or RANDOM3, assign phrases in playback order No. 001 through No. 100, and also assign interrupt phrases to No. 101 through No. 128.

```
2.1 Pattern Phr. A0005
Mode:SEQ
No001 ----- % --.s
Total[00h00m00s00f]
```

END: To finish making settings.

8. Turn the SELECT dial to choose the card containing the phrase you want to store, then press the dial.

```
2.1 Pattern Phr. A0005
Mode:SEQ
No001 [0001 100% 00.0s
Total[00h00m15s00f]
```

9. Turn the SELECT dial to choose the phrase to assign, then press the dial.
 - * Only assignable phrases are displayed.
 - * If phrases are assigned in the playback order you selected in step 7, then selecting "-----" cancels the phrase assignment.
10. Turn the SELECT dial to set the playback volume for the assigned phrase (from 10% to 100%), then press the dial.
 - * If the assigned phrase is a MIDI phrase, you cannot set the

playback volume level.

```
2.1 Pattern Phr. A0005
Mode:SEQ
No001 A0001 [100% 00.0s
Total[00h00m15s00f]
```

Turn the SELECT dial to set the interval for the assigned phrase (from 00.0 to 59.9 sec), then press the dial.

11. Repeat steps 7 through 10 to assign phrases.

- The screen displays the total time for the pattern phrase.

```
2.1 Pattern Phr. A0005
Mode:SEQ
No001 A0001 [100% 00.0s
Total[00h00m15s00f]
```

- * If "-----" is assigned at a number, the interval time for the previous assigned phrase is not added to the total time.
- * The playback time of MIDI phrases is not added to the total time.

12. To cancel the save process, then in step 7, turn the SELECT dial to choose END, then press the dial.

```
2.1 Pattern Phr. A0005
Mode:SEQ
END ----- % --.s
Total[00h00m15s00f]
```

13. When the prompt appears on the screen, press the ENTER button to enable the settings.

To quit without making the settings, use the SELECT dial to choose "NO," then press the ENTER button.

Once the settings have been successfully modified, you're returned to the setting item selection screen.

14. Press the MODE button.

This ends the setting process and returns you to the usual screen.

- * While making the settings, you can go back to the previous entry location (highlighted) by pressing the PAUSE (BACK) button.
- * If you press the MODE button while making settings, a message asking you to confirm that you want to exit the setting process appears. Note that if you choose "YES," then press the ENTER button, you are returned to the usual screen, and all setting changes you've made up to that point will be discarded.

HINT

When Playing Back Narration with Pattern Phrases

With narrations that use pattern phrases, the proper treatment of silent portions is important in order to make the narration sound more natural and easier to understand.

This issue can be addressed as follows:

- Adjust the interval for the pattern phrase.
- Use trigger recording (p. 48) to avoid recording silent

portions.

- Use the playback point phrase settings (p. 55), and the phrase-editing "Truncate" feature (p. 67) to delete silent portions that might be perceived as being odd.

Time-based Combinations (Song Phrases)

You can paste together a number of phrases in temporal (time-flow) order to create a new phrase (song phrase).

A song phrase is a stored combination of phrases that have already been recorded. A song phrase is also treated as a single phrase.

By creating song phrases, you can create time-based phrases, while saving card memory space.

Specific Examples

Try setting the time frame for playback at 15 minutes.

Prepare phrases like the ones described below.

A0030: A 5-minute song

A0031: A 3-minute song

A0032: A 30-second announcement

A0033: A 15-second announcement

A0034: A 6-minute song

Paste these phrases on a time axis to create song phrase A0035 having a total time of 15 minutes.

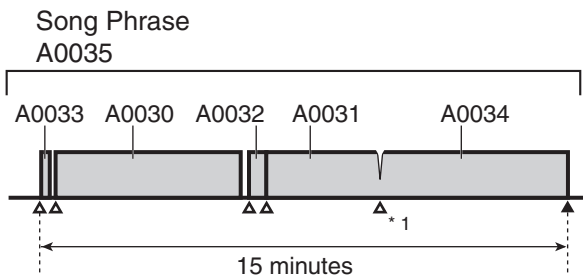

- △ : Start point of phrase (time)
- ▲ : End point of song phrase (time)

*1 If the start point (time) for phrase A0034 is set at a time that overlaps with phrase A0031, playback of A0031 is interrupted and playback of A0034 starts.

- You can assign up to 100 phrases to a single song phrase.
- You can assign a phrase any number of times to a single song phrase, or to more than one song phrase.

NOTE

Playback points and fade settings included in the phrase information for phrases assigned to a song phrase remain in effect, but other phrase information is disregarded. Note that a phrase is assigned to a song phrase in the same state as when it was just recorded (that is, the state before phrase-information settings are made).

NOTE

When you are creating a song phrase, you can choose actual phrases from both card A and card B, but note that the pattern phrase is not played back correctly if the card containing the constituent phrase is not inserted at the time of playback. (If a constituent phrase does not exist, silence is heard until the start point [time] for the next phrase is reached.)

NOTE

Conditions for Creating Song Phrases

- Song phrases that have already been created cannot be assigned to a song phrase.
- Pattern phrases that have already been created cannot be assigned to a song phrase.
- MIDI phrases cannot be assigned to a song phrase.

Procedure for Creating a Song Phrase

1. Press the MODE button.

The MODE indicator lights up.

2. Use the SELECT dial to choose "2.2 Song Phrase," then press the dial.
3. Turn the SELECT dial to choose the card containing an empty phrase for creating a new song phrase or the song phrase whose settings you want to change, then press the dial.

* If a card is inserted into either slot A or slot B, the entry location (highlighted) advances to the phrase number.

4. Turn the SELECT dial to choose the empty phrase for creating a new song phrase or the song phrase whose settings you want to change, then press the dial.

* Only phrases that can be executed are displayed.

5. Turn the SELECT dial to choose the assignment number (from No. 001 to No. 100), then press the dial.

```
2.2 Song Phrase A0005
No. Phrase Start
001 -----
Total [00h00m00s00f]
```

END: To finish making settings.

6. Turn the SELECT dial to choose the card containing the phrase you want to store, then press the dial.

```
2.2 Song Phrase A0005
No. Phrase Start
001 [0001 00h00m00s00f]
Total [00h00m00s00f]
```

* If a card is inserted into either slot A or slot B, the entry location (highlighted) advances to the phrase number.

Turn the SELECT dial to choose the phrase you want to store,

Modifying Recorded Phrases (Phrase Settings)

then press the dial.

* *Only assignable phrases are displayed.*

-----:If a phrase is assigned at the assignment number you selected in step 5, then this cancels the phrase assignment. (However, even after the assignment is canceled, point information is retained.)

STOP: Select this when you want to specify an ending point (time) for the song phrase. (In the specific example on p. 65, this is set at 15 minutes in step 7.)

7. Turn the SELECT dial to set the point (time) to start the assigned phrase, then press the dial.

```
2.2 Song Phrase A0005
No. Phrase Start
001 A0001 00h00m00s00f
Total [00h00m15s00f]
```

If you selected Stop in step 6, then set the end point (time) for the song phrase and press the dial. (In the specific example on p. 65, this is set at 00 h 15 m 00 s 00 f 0 sf.)

8. Repeat steps 5 through 7 to assign phrases.

- The screen displays the total time for the song phrase.

```
2.2 Song Phrase A0005
No. Phrase Start
001 A0001 00h00m00s00f
Total [00h00m15s00f]
```

Total Time

9. To cancel the save process, then in step 5, turn the SELECT dial to choose END, then press the dial.

10. When the prompt appears on the screen, press the ENTER button to enable the settings.

To quit without making the settings, use the SELECT dial to choose "NO," then press the ENTER button.

Once the settings have been successfully modified, you're returned to the setting item selection screen.

11. Press the MODE button.

This ends the setting process and returns you to the usual screen.

* *While making the settings, you can go back to the previous entry location (highlighted) by pressing the PAUSE (BACK) button.*

* *If you press the MODE button while making settings, a message asking you to confirm that you want to exit the setting process appears. Note that if you choose "YES," then press the ENTER button, you are returned to the usual screen, and all setting changes you've made up to that point will be discarded.*

Modifying Phrases Themselves (Phrase Edit)

This is used to modify (edit) recorded phrases.



For settings when a card is formatted, refer to p. 135.

MEMO

To confirm phrases when making settings, you can use the PLAY and STOP buttons to play and stop phrases and the PAUSE button to pause phrases (audio phrases only), and the SELECT dial to move the playback location forward and backward (audio phrases only). Note that you cannot change settings during phrase playback.

NOTE

- Items that can be set differ according to the type of phrase (audio phrase, MIDI phrase, pattern phrase, or song phrase). Also refer to the Phrase Information/Phrase Setting Correspondence Table (p. 75).
- When editing a phrase, you cannot overwrite a phrase itself except by using the phrase delete or truncate functions. Make sure there is enough free space to carry out phrase editing.
- If a card in AR-2000 format is inserted in either slot A or B (or both), the AR-3000R can be used only for playback, and it is not possible to record phrases or make any settings (except for card conversion). Also, if you insert a card in AR-2000 format into slot A or B (or both) while making settings (except for card conversion), operation will halt with an error message, and cannot be resumed until such cards are removed. To record or edit cards in AR-2000 format on the AR-3000R, follow the steps in "Card Convert" (p. 78).
- When the phrase editing described below is carried out, the Phrase Information is not updated.

- Phrase Divide
- Phrase Combine
- Phrase Convert
- Time Stretch

Deleting a Phrase (Phrase Delete)

This deletes a phrase. You can also delete a continuous group of phrases in a batch.

Procedure for Deleting a Phrase

1. Press the MODE button.
The MODE indicator lights up.
2. Use the SELECT dial to choose "3.1 Phrase Delete," then press the dial.
3. Turn the SELECT dial to choose the card containing the beginning phrase you want to delete, then press the dial.

```

3.1 Phrase Delete
Phrase Range
A0001-A0001
Name: [AR-3000 1 ]
    
```

- * If a card is inserted into either slot A or slot B, the entry location (highlighted) advances to the phrase number.

Turn the SELECT dial to choose the beginning phrase to delete, then press the dial.

- * Only phrases that can be executed are displayed.

Turn the SELECT dial to choose the final phrase to delete, then press the dial.

```

3.1 Phrase Delete
Phrase Range
A0001-A0003
Name: [AR-3000 3 ]
    
```

- * Only phrases that can be executed are displayed.
- * To delete a single phrase, choose the same phrase for the beginning phrase and the final phrase.

4. When the prompt appears on the screen, press the ENTER button to enable the settings.

To quit without making the settings, use the SELECT dial to choose "NO," then press the ENTER button.

Once the settings have been successfully modified, you're returned to the setting item selection screen.

5. Press the MODE button.

This ends the setting process and returns you to the usual screen.

- * While making the settings, you can go back to the previous entry location (highlighted) by pressing the PAUSE (BACK) button.
- * If you press the MODE button while making settings, a message asking you to confirm that you want to exit the setting process appears. Note that if you choose "YES," then press the ENTER button, you are returned to the usual screen, and all setting changes you've made up to that point will be discarded.

Deleting Audio Outside the Playback Points (Phrase Truncate)

This deletes data outside the points set with the Playback Point phrase information (p. 55). You can also truncate a continuous group of phrases in a batch.

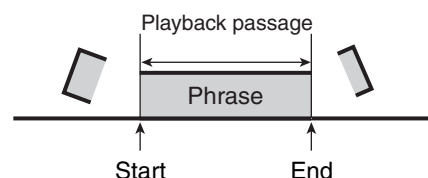

Modifying Recorded Phrases (Phrase Settings)

NOTE

Truncate acts upon and modifies the selected phrase itself. Care must be taken, since once it has been executed, the phrase cannot be restored to its original state.

NOTE

You cannot make these settings for MODE2 phrases.

Phrase Truncate Procedure

1. Press the MODE button.
The MODE indicator lights up.
2. Use the SELECT dial to choose "3.2 Phrase Truncate," then press the dial.
3. Turn the SELECT dial to choose the card containing the beginning phrase for truncation, then press the dial.

```

3.2 Phrase Truncate
Phrase Range
A0001-A0001
Name: [AR-3000 1 ]
    
```

* If a card is inserted into either slot A or slot B, the entry location (highlighted) advances to the phrase number.

Turn the SELECT dial to choose the beginning phrase for truncation, then press the dial.

* Only phrases that can be executed are displayed.

Turn the SELECT dial to choose the final phrase for truncation, then press the dial.

* Only phrases that can be executed are displayed.

* To truncate a single phrase, choose the same phrase for the beginning phrase and the final phrase.

4. When the prompt appears on the screen, press the ENTER button to enable the settings.

To quit without making the settings, use the SELECT dial to choose "NO," then press the ENTER button.

Once the settings have been successfully modified, you're returned to the setting item selection screen.

5. Press the MODE button.

This ends the setting process and returns you to the usual screen.

* While making the settings, you can go back to the previous entry location (highlighted) by pressing the PAUSE (BACK) button.

* If you press the MODE button while making settings, a message asking you to confirm that you want to exit the setting process appears. Note that if you choose "YES," then press the ENTER button, you are returned to the usual screen, and all setting changes you've made up to that point will be discarded.

Copying a Phrase (Phrase Copy)

This copies a phrase. You can also copy a continuous group of phrases in a batch.

NOTE

Important Notes About Copying a Continuous Group of Phrases in a Batch

Example: Copying a continuous range of phrases from A0050 to A0053

If A0052 happens to be a used empty phrase, then specify a continuous group of three empty phrases as the beginning. (The system seeks and displays only writable phrases.)

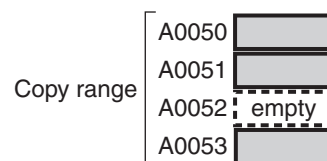

Phrase Copy

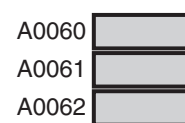

Three continuous empty phrases at the write destination

NOTE

Important Notes About Copying Pattern Phrases or Song Phrases

For pattern phrases and song phrases, only the combination information is copied. Note that the actual constituent phrases are not copied.

Example:

- When a pattern phrase or song phrase on the same card is copied
→ The actual constituent phrases exist, so playback is correct.

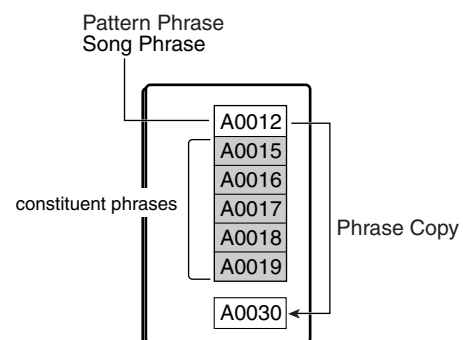

- When a pattern phrase or song phrase is copied between different cards (A → B)
→ Playback is correct while card A is inserted in the slot (and

the actual phrases are present), but if card A is removed or card B is inserted into slot A, the actual constituent phrases are no longer present, and so playback is not correct. To ensure that a pattern phrase or song pattern copied to a different card (A → B) is played back correctly, copy the actual constituent phrases separately to card B.

In such cases, with regard to the constituent phrases of the pattern phrases and song phrases, the actual phrases should be reregistered after the copying is complete.

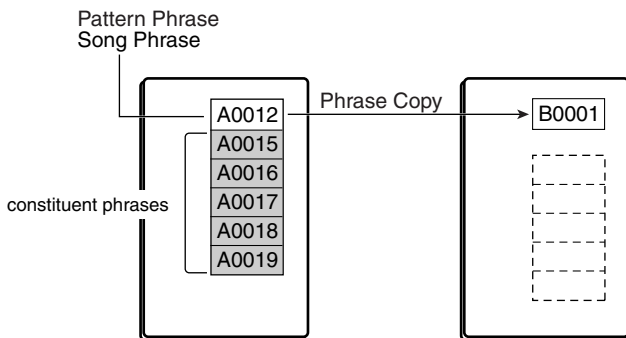

Procedure for Copying a Phrase

1. Press the MODE button.

The MODE indicator lights up.

2. Use the SELECT dial to choose "3.3 Phrase Copy," then press the dial.
3. Turn the SELECT dial to choose the card containing the beginning phrase of the copy source, then press the dial.

```

3.3 Phrase Copy
Phrase Range  Dest
A0001-A0001 -> A0005
Name: [AR-3000 1 ]
    
```

* If a card is inserted into either slot A or slot B, the entry location (highlighted) advances to the phrase number.

Turn the SELECT dial to choose the beginning phrase at the copy source, then press the dial.

* Only phrases that can be executed are displayed.

Turn the SELECT dial to choose the final phrase of the copy source, then press the dial.

* Only phrases that can be executed are displayed.

* To copy a single phrase, choose the same phrase for the beginning phrase and the final phrase.

4. Turn the SELECT dial to choose the write-destination card, then press the dial.

```

3.3 Phrase Copy
Phrase Range  Dest
A0001-A0003 -> A0005
    
```

* If a card is inserted into either slot A or slot B, the entry location (highlighted) advances to the phrase number.

Turn the SELECT dial to choose the beginning phrase for the write destination, then press the dial.

* Only phrases that can be executed are displayed.

5. When the prompt appears on the screen, press the ENTER button to enable the settings.

To quit without making the settings, use the SELECT dial to choose "NO," then press the ENTER button.

Once the settings have been successfully modified, you're returned to the setting item selection screen.

6. Press the MODE button.

This ends the setting process and returns you to the usual screen.

* While making the settings, you can go back to the previous entry location (highlighted) by pressing the PAUSE (BACK) button.

* If you press the MODE button while making settings, a message asking you to confirm that you want to exit the setting process appears. Note that if you choose "YES," then press the ENTER button, you are returned to the usual screen, and all setting changes you've made up to that point will be discarded.

Dividing a Phrase (Phrase Divide)

This splits a phrase at the location you specify, creating two phrases.

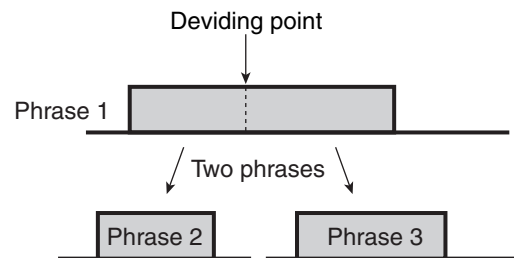

NOTE

You cannot make these settings for MODE2 phrases.

Procedure for Dividing a Phrase

1. Press the MODE button.

The MODE indicator lights up.

2. Use the SELECT dial to choose "3.4 Phrase Divide," then press the dial.
3. Turn the SELECT dial to choose the card containing the phrase you want to split, then press the dial.

```

3.4 Phrase Divide
A0001 -> A0005 A0006
Name: [AR-3000 1 ]
    
```

* If a card is inserted into either slot A or slot B, the entry location (highlighted) advances to the phrase number.

Turn the SELECT dial to choose the phrase to split, then press the dial.

Modifying Recorded Phrases (Phrase Settings)

* Only phrases that can be executed are displayed.

- Turn the SELECT dial to set the split point (time), then press the dial.

```
3.4 Phrase Divide
A0001 -> A0005 A0006
Point: 00h00m22s00f0sf
```

HINT

You can set the points while listening to the audio by using the SCRUB playback mode (p. 54). Also, you can use TO (to split point) and FROM (from split point) to listen to audio for a fixed time before and after the split point.

- Turn the SELECT dial to choose the card for write destination 1, then press the dial.

```
Destination 1 Destination 2
3.4 Phrase Divide
A0031 -> A0005 A0006
Point: 00h00m22s00f0sf
```

* If a card is inserted into either slot A or slot B, the entry location (highlighted) advances to the phrase number.

Turn the SELECT dial to choose the phrase for write destination 1, then press the dial.

* Only phrases that can be executed are displayed.

- Turn the SELECT dial to choose the card for write destination 2, then press the dial.

```
3.4 Phrase Divide
A0031 -> A0005 A0006
Point: 00h00m22s00f0sf
```

* If a card is inserted into either slot A or slot B, the entry location (highlighted) advances to the phrase number.

Turn the SELECT dial to choose the phrase for write destination 2, then press the dial.

* Only phrases that can be executed are displayed.

- When the prompt appears on the screen, press the ENTER button to enable the settings.

To quit without making the settings, use the SELECT dial to choose "NO," then press the ENTER button.

Once the settings have been successfully modified, you're returned to the setting item selection screen.

- Press the MODE button.

This ends the setting process and returns you to the usual screen.

* While making the settings, you can go back to the previous entry location (highlighted) by pressing the PAUSE (BACK) button.

* If you press the MODE button while making settings, a message asking you to confirm that you want to exit the

setting process appears. Note that if you choose "YES," then press the ENTER button, you are returned to the usual screen, and all setting changes you've made up to that point will be discarded.

Joining Phrases (Phrase Combine)

This joins two phrases, creating a single phrase.

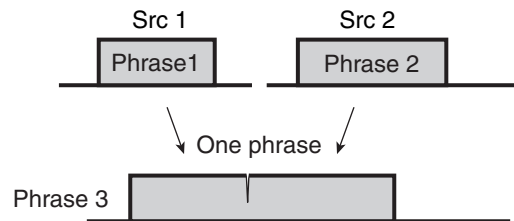

* Phrase Combine cannot be executed unless the RDAC-Grade, RDAC-Mode, and recording type are the same for both phrases.

NOTE

You cannot make these settings for MODE2 phrases.

Procedure for Joining Phrases

- Press the MODE button.

The MODE indicator lights up.

- Use the SELECT dial to choose "3.5 Phrase Combine," then press the dial.

- Turn the SELECT dial to choose the card containing the first phrase to join (Src1), then press the dial.

```
3.5 Phrase Combine
Src1 Src2 Write
A0001 A0001 -> A0005
Name: [AR-3000 1 ]
```

* If a card is inserted into either slot A or slot B, the entry location (highlighted) advances to the phrase number.

Turn the SELECT dial to choose the first phrase to join (Src1), then press the dial.

* Only phrases that can be executed are displayed.

- Turn the SELECT dial to choose the card containing the second phrase to join (Src2), then press the dial.

```
3.5 Phrase Combine
Src1 Src2 Write
A0001 A0001 -> A0005
Name: [AR-3000 1 ]
```

* If a card is inserted into either slot A or slot B, the entry location (highlighted) advances to the phrase number.

Turn the SELECT dial to choose the second phrase to join (Src2), then press the dial.

* Only phrases that can be executed are displayed.

- Turn the SELECT dial to choose the write-destination card, then press the dial.

```

3.5 Phrase Combine
Src1 Src2 Write
A0001 A0011 -> A0005
    
```

* If a card is inserted into either slot A or slot B, the entry location (highlighted) advances to the phrase number.

Turn the SELECT dial to choose the write-destination phrase, then press the dial.

* Only phrases that can be executed are displayed.

- When the prompt appears on the screen, press the ENTER button to enable the settings.

To quit without making the settings, use the SELECT dial to choose "NO," then press the ENTER button.

Once the settings have been successfully modified, you're returned to the setting item selection screen.

- Press the MODE button.

This ends the setting process and returns you to the usual screen.

* While making the settings, you can go back to the previous entry location (highlighted) by pressing the PAUSE (BACK) button.

* If you press the MODE button while making settings, a message asking you to confirm that you want to exit the setting process appears. Note that if you choose "YES," then press the ENTER button, you are returned to the usual screen, and all setting changes you've made up to that point will be discarded.

Expanding or Compressing the Playback Time Without Changing the Pitch (Time Stretch)

This expands or compresses a phrase's playback time without changing its pitch. You can set a value within a range of -20.0% to +20.0% of the phrase's original playback time.

* The playback time after stretching is displayed simultaneously.

NOTE

The displayed playback time after stretching is only a rough guide, and may not match the actual playback time after conversion.

NOTE

You cannot make these settings for MODE2 phrases.

Time Stretch Procedure

- Press the MODE button.
The MODE indicator lights up.

- Use the SELECT dial to choose "3.6 Time Stretch," then press the dial.

```

3.6 Time Stretch
A0001 0.0% -> A0005
Name: [AR-3000 1 ]
    
```

* If a card is inserted into either slot A or slot B, the entry location (highlighted) advances to the phrase number.

Turn the SELECT dial to choose the phrase whose time you want to stretch, then press the dial.

* Only phrases that can be executed are displayed.

- Turn the SELECT dial to set the degree of stretching (from -20.0% to +20.0%), then press the dial.

	Original playback time
<pre style="margin: 0;"> 3.6 Time Stretch A0001 +10.0% -> A0005 Original 00h00m01s15f Stretch 00h00m01s19f </pre>	
	Playback time after stretching

- Turn the SELECT dial to choose the write-destination card, then press the dial.

```

3.6 Time Stretch
A0001 +10.0% -> A0005
Original 00h00m01s15f
Stretch 00h00m01s19f
    
```

* Only executable cards are displayed.

Turn the SELECT dial to choose the write-destination phrase, then press the dial.

* Only phrases that can be executed are displayed.

- When the prompt appears on the screen, press the ENTER button to enable the settings.

To quit without making the settings, use the SELECT dial to choose "NO," then press the ENTER button.

Once the settings have been successfully modified, you're returned to the setting item selection screen.

- Press the MODE button.

This ends the setting process and returns you to the usual screen.

* While making the settings, you can go back to the previous entry location (highlighted) by pressing the PAUSE (BACK) button.

* If you press the MODE button while making settings, a message asking you to confirm that you want to exit the setting process appears. Note that if you choose "YES," then press the ENTER button, you are returned to the usual screen, and all setting changes you've made up to that point will be discarded.

Modifying Recorded Phrases (Phrase Settings)

Converting a Phrase's Recording Settings (Phrase Convert)

This converts the recording-setting items RDAC-Mode and recording type to other settings while leaving phrase content unchanged.

RDAC-Mode (Signal Processing Format)

- **H-LINEAR:** 24-bit PCM recording
- **LINEAR:** 16-bit PCM recording
- **MODE3:** Approximately 2.5 times the recording time available with LINEAR
- **MODE2:** Approximately 2.5 times the recording time available with LINEAR, or longer
- **MODE1:** Approximately 4 times the recording time available with LINEAR



The RDAC mode is converted at times like these.

- When conducting Dual Mono mode (p. 120) two-channel simultaneous playback (In the Dual Mono mode, simultaneous playback is not possible unless the phrases are uniformly RDAC-Mode.)
- When conducting multiple-unit simultaneous playback with AR-LINK (p. 123) (With AR-LINK playback, simultaneous playback is not possible unless the phrases are uniformly RDAC-Mode.)
- When phrases recorded with H-LINEAR or MODE3 on the AR-3000R are used on the AR-2000 or the like (H-LINEAR and MODE3 phrases cannot be used unchanged on the AR-2000.)



Please be aware that conversion to a higher level does not enhance the sound quality.

Recording Type

- STEREO
- MONO



The recording type is converted at times like these.

- When conducting two-channel simultaneous playback in the Dual Mono mode (p. 123) (In the Dual Mono mode, simultaneous playback is not possible unless the phrases are mono.)

- When conducting multiple-unit simultaneous playback with AR-LINK (p. 123) (With AR-LINK playback, simultaneous playback is not possible unless the phrases are of the same recording type.)

<Conversion of a single stereo phrase to a single mono phrase: STEREO → MONO>

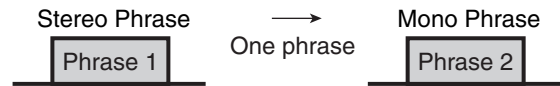

You can also convert the recording type in the same way.

<Conversion of a single stereo phrase to two mono phrases: STEREO → MONO 1, 2>

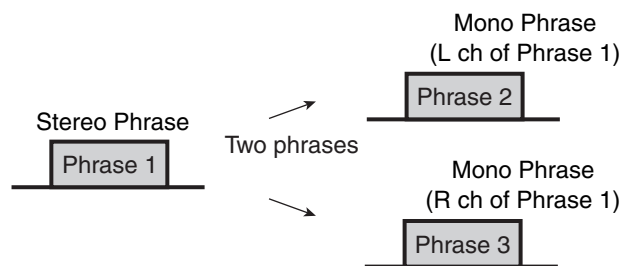

<Conversion of two mono phrases to a single stereo phrase: MONO 1, 2 → STEREO>

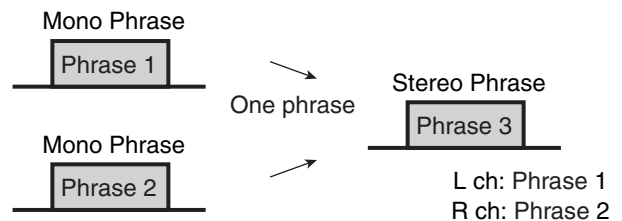

Procedure for Phrase Convert

● Converting the RDAC-Mode

1. Press the MODE button.

The MODE indicator lights up.

2. Use the SELECT dial to choose "3.7 Phrase Convert," then press the dial.

3. Turn the SELECT dial to choose RDAC-Mode, then press the dial.

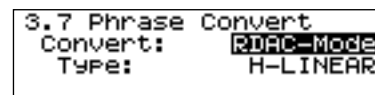

4. Turn the SELECT dial to choose RDAC-Mode type (H-LINEAR/LINEAR/MODE3/MODE2/MODE1), then press the dial.

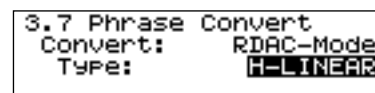

- Turn the SELECT dial to choose the card containing the beginning phrase you want to convert, then press the dial.

```

3.7 Phrase Convert
Phrase Range  Dest
A0001-A0001 -> A0005
Name: [AR-3000 1 ]
    
```

* If a card is inserted into either slot A or slot B, the entry location (highlighted) advances to the phrase number.

Turn the SELECT dial to choose the beginning phrase to convert, then press the dial.

* Only phrases that can be executed are displayed.

Turn the SELECT dial to choose the final phrase to convert, then press the dial.

* Only phrases that can be executed are displayed.

* To convert a single phrase, choose the same phrase for the beginning phrase and the final phrase.

- Turn the SELECT dial to choose the write-destination card, then press the dial.

```

3.7 Phrase Convert
Phrase Range  Dest
A0001-A0011 -> A0005
    
```

* If a card is inserted into either slot A or slot B, the entry location (highlighted) advances to the phrase number.

Turn the SELECT dial to choose the beginning phrase for the write destination, then press the dial.

```

3.7 Phrase Convert
Phrase Range  Dest
A0001-A0011 -> A0015
    
```

* Only phrases that can be executed are displayed.

- When the prompt appears on the screen, press the ENTER button to enable the settings.

To quit without making the settings, use the SELECT dial to choose "NO," then press the ENTER button.

Once the settings have been successfully modified, you're returned to the setting item selection screen.

- Press the MODE button.

This ends the setting process and returns you to the usual screen.

* While making the settings, you can go back to the previous entry location (highlighted) by pressing the PAUSE (BACK) button.

* If you press the MODE button while making settings, a message asking you to confirm that you want to exit the setting process appears. Note that if you choose "YES," then press the ENTER button, you are returned to the usual screen, and all setting changes you've made up to that point will be discarded.

MEMO

Even if there are phrases in "Phrase range" that have the same RDAC-Mode as the set RDAC-Mode, it is written unchanged as a new phrase.

● Converting the Recording Type

- Press the MODE button.

The MODE indicator lights up.

- Use the SELECT dial to choose "3.7 Phrase Convert," then press the dial.

- Turn the SELECT dial to choose the recording type, then press the dial.

```

3.7 Phrase Convert
Convert:      REC Type
Type:        STEREO->MONO
    
```

- Turn the SELECT dial to choose the recording-type conversion method (STEREO → MONO, STEREO → MONO 1, 2, or MONO 1, 2 → STEREO), then press the dial.

```

3.7 Phrase Convert
Convert:      REC Type
Type:        STEREO->MONO
    
```

When "STEREO → MONO" Is Selected

- Turn the SELECT dial to choose the card containing the beginning phrase you want to convert, then press the dial.

```

3.7 Phrase Convert
STEREO        MONO
A0011-A0011 -> A0005
Name: [AR-3000 11 ]
    
```

* If a card is inserted into either slot A or slot B, the entry location (highlighted) advances to the phrase number.

Turn the SELECT dial to choose the beginning phrase to convert, then press the dial.

* Only phrases that can be executed are displayed.

Turn the SELECT dial to choose the final phrase to convert, then press the dial.

* Only phrases that can be executed are displayed.

* To convert a single phrase, choose the same phrase for the beginning phrase and the final phrase.

- Turn the SELECT dial to choose the write-destination card, then press the dial.

```

3.7 Phrase Convert
STEREO        MONO
A0011-A0031 -> A0005
    
```

* If a card is inserted into either slot A or slot B, the entry location (highlighted) advances to the phrase number.

Modifying Recorded Phrases (Phrase Settings)

- Turn the SELECT dial to choose the beginning phrase for the write destination, then press the dial.

```
3.7 Phrase Convert
STEREO      MONO
A0011-A0031 -> A0005
```

* Only phrases that can be executed are displayed.

- When the prompt appears on the screen, press the ENTER button to enable the settings.

To quit without making the settings, use the SELECT dial to choose "NO," then press the ENTER button.

Once the settings have been successfully modified, you're returned to the setting item selection screen.

- Press the MODE button.

This ends the setting process and returns you to the usual screen.

● When "STEREO → MONO 1, 2" Is Selected

- Turn the SELECT dial to choose the card containing the stereo phrase you want to convert, then press the dial.

```
3.7 Phrase Convert
STEREO      MONO1  MONO2
A0011 -> A0005  A0006
Name: [AR-3000 11 ]
```

* If a card is inserted into either slot A or slot B, the entry location (highlighted) advances to the phrase number.

Turn the SELECT dial to choose the stereo phrase to convert, then press the dial.

* Only phrases that can be executed are displayed.

- Turn the SELECT dial to choose the card for write destination 1 (MONO1), then press the dial.

```
3.7 Phrase Convert
STEREO      MONO1  MONO2
A0011 -> A0005  A0006
```

* If a card is inserted into either slot A or slot B, the entry location (highlighted) advances to the phrase number.

Turn the SELECT dial to choose the phrase for write destination 1, then press the dial.

* Only phrases that can be executed are displayed.

- Turn the SELECT dial to choose the card for write destination 2 (MONO2), then press the dial.

```
3.7 Phrase Convert
STEREO      MONO1  MONO2
A0011 -> A0005  A0006
```

* If a card is inserted into either slot A or slot B, the entry location (highlighted) advances to the phrase number.

Turn the SELECT dial to choose the phrase for write destination 2, then press the dial.

* Only phrases that can be executed are displayed.

- When the prompt appears on the screen, press the ENTER button to enable the settings.

To quit without making the settings, use the SELECT dial to choose "NO," then press the ENTER button.

Once the settings have been successfully modified, you're returned to the setting item selection screen.

- Press the MODE button.

This ends the setting process and returns you to the usual screen.

● When "MONO 1, 2 → STEREO" Is Selected

- Turn the SELECT dial to choose the card containing the first mono phrase 1 (MONO1) you want to convert, then press the dial.

```
3.7 Phrase Convert
MONO1  MONO2  STEREO
A0001  A0001 -> A0005
Name: [AR-3000 1 ]
```

* If a card is inserted into either slot A or slot B, the entry location (highlighted) advances to the phrase number.

Turn the SELECT dial to choose the first mono phrase 1 to convert, then press the dial.

* Only phrases that can be executed are displayed.

- Turn the SELECT dial to choose the card containing the second mono phrase 2 (MONO2) you want to convert, then press the dial.

```
3.7 Phrase Convert
MONO1  MONO2  STEREO
A0001  A0001 -> A0005
Name: [AR-3000 1 ]
```

* If a card is inserted into either slot A or slot B, the entry location (highlighted) advances to the phrase number.

Turn the SELECT dial to choose the second mono phrase 2 to convert, then press the dial.

* Only phrases that can be executed are displayed.

- Turn the SELECT dial to choose the write-destination card, then press the dial.

```
3.7 Phrase Convert
MONO1  MONO2  STEREO
A0001  A0021 -> A0005
```

* If a card is inserted into either slot A or slot B, the entry location (highlighted) advances to the phrase number.

Turn the SELECT dial to choose the write-destination phrase, then press the dial.

* Only phrases that can be executed are displayed.

- When the prompt appears on the screen, press the ENTER button to enable the settings.

To quit without making the settings, use the SELECT dial to choose "NO," then press the ENTER button.

Modifying Recorded Phrases (Phrase Settings)

Once the settings have been successfully modified, you're returned to the setting item selection screen.

9. Press the MODE button.

This ends the setting process and returns you to the usual screen.

* While making the settings, you can go back to the previous entry location (highlighted) by pressing the PAUSE (BACK) button.

- * If you press the MODE button while making settings, a message asking you to confirm that you want to exit the setting process appears. Note that if you choose "YES," then press the ENTER button, you are returned to the usual screen, and all setting changes you've made up to that point will be discarded.
- * When two monaural phrases of differing grades are converted to stereo, the playback pitch in one of the channels may change.

Phrase Information/Phrase Setting Correspondence Table

O : Can be set
X : Not set

Phrase Settings	Phrases					AR-LINK Playback	Dual Mono Mode (ON)	
	Audio		MIDI	Pattern	Song			
	RDAC-Mode: MODE2	RDAC-Mode: except MODE2						
1 Phrase Information	●1.1 Play Volume	O	O	X	O	O	O *2	O
	●1.2 Delay Time	O	O	O	O	O	O *2	O
	●1.3 Playback Point	O	X	X	X	X	O *2	O
	●1.4 Repeat Play	O	O	O	O	O	X	O
	●1.5 Loop Play	O	X	X	X	X	X	X
	●1.6 Fade	O	O	X	X	X	O *2	O
	●1.7 Control Out	O	O	O	O	O	X	X
	●1.8 MIDI Tempo	X	X	O	X	X	X	X
	●1.9 Phrase Name	O	O	O	O	O	O	O
3 Phrase Edit	●3.1 Phrase Delete	O	O	O	O	O	/	/
	●3.2 Phrase Truncate	O	X	X	X	X		
	●3.3 Phrase Copy	O	O	O	O *1	O *1		
	●3.4 Phrase Divide	O	X	X	X	X		
	●3.5 Phrase Combine	O	X	X	X	X		
	●3.6 Time Stretch	O	X	X	X	X		
	●3.7 Phrase Convert	O	O	X	X	X		

*1 The actual constituent phrases are not copied.

*2 The AR-LINK slave operates in accord with the data from the master.

Making Settings and Edits for Individual Cards

You can make batch settings and edits for individual cards.

NOTE

If a card in AR-2000 format is inserted in either slot A or B (or both), the AR-3000R can be used only for playback, and it is not possible to record phrases or make any settings (except for card conversion). Also, if you insert a card in AR-2000 format into slot A or B (or both) while making settings (except for card conversion), note that the operation halts with an error message, and the operation cannot be resumed until the card or card is removed. To record or edit cards in AR-2000 format on the AR-3000R, follow the steps in "Card Convert" (p. 78).

Making a Card Usable on the AR-3000R (Card Format)

When you use a new card or a card used previously on a device other than the unit, you must first format the card. For an explanation of how to format the card, refer to "Formatting a Card" (p. 31).

NOTE

Performing formatting erases all data on the card. Before you format the card, make sure it contains no data you don't want to lose.

Deleting All Phrases on a Card (Card Delete)

This deletes all the phrases on a card.

NOTE

Please be aware that performing a Card Delete operation deletes all phrase data. (This returns the card to the state it was in when freshly formatted.)

Card Delete Procedure

1. Press the MODE button.
The MODE indicator lights up.
2. Use the SELECT dial to choose "4.2 Card Delete," then press the dial.
3. Turn the SELECT dial to choose the card to delete (A or B), then press the dial.

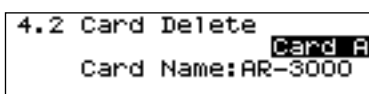

```
4.2 Card Delete
Card Name: AR-3000
```

4. When the prompt appears on the screen, press the ENTER button to enable the settings.

To quit without making the settings, use the SELECT dial to choose "NO," then press the ENTER button.

When the operation ends, the display returns to the setting item selection screen.

5. Press the MODE button.

This ends the setting process and returns you to the usual screen.

* Pressing the MODE button while making the setting displays a prompt asking you whether you want to quit making the setting. Note that choosing "YES" and pressing the ENTER button returns you to the usual screen, discarding any settings made up to that point.

Copying a Card (Card Copy)

This copies the data on the card in slot A to the card in slot B. Card A and card B don't have to be the same size (capacity), but unless the usable space on card B is larger than the space used on card A, you cannot copy everything on card A to card B.

NOTE

Please be aware that performing a "Card Copy" operation deletes (overwrites) the data on card B.

NOTE

A card in AR-2000 format cannot be copied as-is. To copy a card in AR-2000 format, use Card Convert to convert it to AR-3000 format, then copy the card.



Card Convert → p. 78

Card Copy Procedure

1. Press the MODE button.
The MODE indicator lights up.
2. Use the SELECT dial to choose "4.3 Card Copy (A→B)," then press the dial.
3. Insert the card to copy from into slot A and the card to copy to into slot B, then press the SELECT dial.
* Be sure to insert the cards into the correct slots.
4. When the prompt appears on the screen, press the ENTER button to enable the settings.

To quit without making the settings, use the SELECT dial to choose "NO," then press the ENTER button.

When the operation ends, the display returns to the setting item selection screen.

5. Press the MODE button.

This ends the setting process and returns you to the usual screen.

* Pressing the MODE button while making the setting displays a prompt asking you whether you want to quit making the setting. Note that choosing "YES" and pressing the ENTER button returns you to the usual screen, discarding any settings made up to that point.

Copying Just the Settings (Setting Copy)

This copies the following setting information stored on the card in slot A to the card in slot B.

- Control input settings
- MIDI settings
- RS-232C settings
- AR-LINK settings
- System settings

NOTE

You cannot copy settings to a card that has a different format (that is, you cannot copy settings from a card in AR-2000 format to a card in AR-3000 format, or vice versa).

Setting Copy Procedure

1. Press the MODE button.
The MODE indicator lights up.
2. Use the SELECT dial to choose "4.4 Setting Copy (A→B)," then press the dial.
3. Insert the card to copy from into slot A and the card to copy to into slot B, then press the SELECT dial.
* Be sure to insert the cards into the correct slots.
4. When the prompt appears on the screen, press the ENTER button to enable the settings.

To quit without making the settings, use the SELECT dial to choose "NO," then press the ENTER button.

When the operation ends, the display returns to the setting item selection screen.

5. Press the MODE button.

This ends the setting process and returns you to the usual screen.

* Pressing the MODE button while making the setting displays a prompt asking you whether you want to quit making the setting. Note that choosing "YES" and pressing the ENTER button returns you to the usual screen, discarding any settings made up to that point.

Protecting a Card (Card Protect)

This prohibits such card operations as saving, overwriting, deleting, and editing. (However, playback and copying phrases to another card are still possible.)

Procedure for Making the Card Protect Setting

1. Press the MODE button.
The MODE indicator lights up.
2. Use the SELECT dial to choose "4.5 Card Protect," then press the dial.
3. Turn the SELECT dial to choose the card you want to protect (A or B), then press the dial.

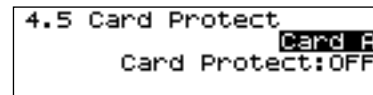

4. Turn the SELECT dial to choose Card Protect (OFF or ON), then press the dial.
5. When the prompt appears on the screen, press the ENTER button to enable the settings.

To quit without making the settings, use the SELECT dial to choose "NO," then press the ENTER button.

When you're finished making the setting, the display returns to the setting item selection screen.

6. Press the MODE button.

This ends the setting process and returns you to the usual screen.

* While making the settings, you can go back to the previous entry position (highlighted) by using the PAUSE (BACK) button.

* Pressing the MODE button while making the setting displays a prompt asking you whether you want to quit making the setting. Note that choosing "YES" and pressing the ENTER button returns you to the usual screen, discarding any settings made up to that point.

Changing the Name of a Card (Card Name)

This changes the name assigned to a card when it was formatted (p. 31).

When you record a phrase, this card name is automatically added to the beginning of the phrase name. You can enter a card name of up to eight characters.

Example:

Card name before change: MESSAGE

→ Phrase name: MESSAGE 1

Card name after change: ENTRANCE

Making Settings and Edits for Individual Cards

If you record a new phrase 0002 after changing the card name, it is given "ENTRANCE 2" as the phrase name.

- * The name of phrase 0001, which was recorded before changing the card name, remains unchanged ("MESSAGE 1").
- * In a phrase name, the number after the card name indicates the phrase number.

Procedure for Changing the Card Name

1. Press the MODE button.

The MODE indicator lights up.

2. Use the SELECT dial to choose "4.6 Card Name," then press the dial.
3. Turn the SELECT dial to choose the card whose name you want to change (A or B), then press the dial.
4. Turn the SELECT dial to choose a character. Press the dial to confirm the selected character.

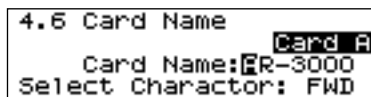

- **Characters you can use:** Letters of the alphabet (uppercase) space numerals - ! # \$ % & ' () @ ^ _ { }
 - **FWD:** This advances the location for entering a character. Pressing the dial advances the entry location by one.
 - **BACK:** This moves back the location for entering a character. Pressing the dial moves back the entry location by one.
 - **INS:** This inserts a space. Pressing the dial inserts a single space.
 - **DEL:** This deletes a character. Pressing the dial deletes a single character.
 - **END:** This finishes the setting process.
5. To quit saving, turn the SELECT dial to choose "END" in step 3, then press the dial.

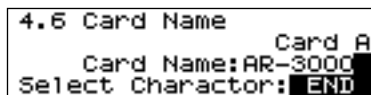

6. When the prompt appears on the screen, press the ENTER button to enable the settings.

To quit without making the settings, use the SELECT dial to choose "NO," then press the ENTER button.

When you're finished making the setting, the display returns to the setting item selection screen.

7. Press the MODE button.

This ends the setting process and returns you to the usual screen.

- * While making the settings, you can go back to the previous entry position (highlighted) by using the PAUSE (BACK) button.
- * Pressing the MODE button while making the setting displays a prompt asking you whether you want to quit making the setting. Note that choosing "YES" and pressing the ENTER button returns you to the usual screen, discarding any settings made up to that point.

Making Cards for Legacy Models Usable on the AR-3000R (Card Convert)

■ What Is Card Convert?

With the AR-3000R, you can play back cards in AR-2000 format (from models AR-2000/100) without having to make any changes, but you cannot edit or change settings (write or rewrite) on such cards.

Also, the legacy models AR-2000/100 can play back cards in AR-3000 format without having to make any changes, but cannot be used to edit or change settings (write or rewrite) on such cards.

"Card Convert" is a feature that lets you take a card in AR-2000 format and play it back, change settings, and edit (write or overwrite) it with the AR-3000R, or vice versa.



Card Compatibility with Other Models in the AR Series → p. 34

■ Conversion of New Functions on the AR-3000R

When you convert a card in AR-3000 format to a card in AR-2000 format, the AR-3000R setting items are converted as shown in the "Card Conversion Chart" (p. 80).

On legacy models such as the AR-2000, items set on the AR-3000R are grouped into the following four types.

- Effective without change
- Converted to similar values
- Not valid
- Result in an error and halt conversion



- Cards for which the maximum number of phrases was set at 1,000 when formatted cannot be converted.
- The settings for items which are not valid or are converted to similar values are lost and cannot be recovered even by formatting the AR-3000R again.

Also, for items which result in an error and cause conversion to stop, it is necessary to perform processing such as phrase conversion, truncating phrases, and backing up and deleting

to eliminate the cause of the error. (For information on error-causing items and remedies, refer to “Conversion Error List” (p. 80).)

- If you are using the AR-3000R to perform recording or editing on a card used on an AR-2000, we recommend making settings only for items that remain effective without change when the card is converted to AR-2000 format.

■ Conversion Using a Single Card and Conversion Using Two Cards

With Card Convert, in addition to converting a single card (the card itself), you can perform conversion while copying one card (the source) to another card (the destination).

We recommend converting using two cards when you want to leave what is on the card unconverted. When you perform conversion using two cards, insert the copy-source card into slot A and the copy-destination card into slot B.

NOTE

When you are converting using two cards, the copy-source card and the copy-destination card don't have to be the same size (capacity), but you can perform Card Convert only when the usable space on the destination card is larger than the space used on the source card.

NOTE

When you convert data in AR-2000 format to AR-3000 format, the amount of data after conversion increases slightly. This means that even if you are converting the same card (conversion using a single card) or two cards that have the same capacity (conversion using two cards), it may not be possible to perform conversion if there is no more free space or if there is little free space remaining. If this happens, then reduce the amount of data on the copy-source card, such as by deleting unneeded phrases.

Procedure for Card Convert

1. Press the MODE button.
The MODE indicator lights up.
2. Use the SELECT dial to choose “4.7 Card Convert,” then press the dial.
3. Turn the SELECT dial to choose the Convert, then press the dial.

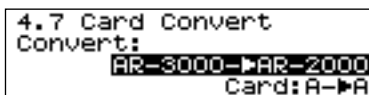

- **AR-3000** → **AR-2000**: This converts a card in AR-3000 format to AR-2000 format.
- **AR-2000** → **AR-3000**: This converts a card in AR-2000

format to AR-3000 format.

4. Turn the SELECT dial to choose the Card you want to convert, then press the dial.

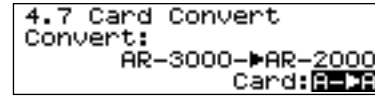

- **A** → **A**: This converts a single card (the card itself).
- **A** → **B**: This converts card A (the copy source) to card B (the copy destination).

* Be sure to insert the cards into the correct slots.

5. When the prompt appears on the screen, press the ENTER button to enable the settings.

To quit without making the settings, use the SELECT dial to choose “NO,” then press the ENTER button.

When the operation ends, the display returns to the setting item selection screen.

6. Press the MODE button.

This ends the setting process and returns you to the usual screen.

* While making the settings, you can go back to the previous entry position (highlighted) by using the PAUSE (BACK) button.

* Pressing the MODE button while making the setting displays a prompt asking you whether you want to quit making the setting. Note that choosing “YES” and pressing the ENTER button returns you to the usual screen, discarding any settings made up to that point.

Card Conversion Chart/Conversion Error Chart

Card Conversion (AR-3000→AR-2000)Chart

* This chart shows compatibility for converted cards used on the AR-2000.
When you're using on the AR-100 or AR-1, refer to the owner's manual for the respective device.

- Effective without change
- ◆ Converted to similar values
- × Not valid
- ▲ Result in an error and halt conversion

State of recording settings

●REC-In (Selecting the Recording Connector)

- LINE-IN ◆ MIDI Rec: OFF
- LINE+MIC-IN ◆ MIDI Rec: OFF
- DIGITAL-IN ◆ MIDI Rec: OFF
- MIDI-IN ◆ MIDI Rec: ON

●RDAC-Grade

- ANNOUNCE ○
- LONG2 ○
- LONG1 ○
- STANDARD ○
- HIGH ○
- S-HIGH ◆ HIGH

●RDAC-Mode

- MODE1 ○
- MODE2 ○
- MODE3 ◆ MODE2
- LINEAR ◆ MODE2
- H-LINEAR ◆ MODE2

●REC Type

- STEREO ○
- MONO ○

●Trig Level (Trigger Recording Settings)

- OFF ○
- LOW ○
- MID ○
- HIGH ○

●MIDI Time Base

- 192 ○
- 240 ○

Recording settings for recorded phrased

●RDAC-Grade

- ANNOUNCE ○
- LONG2 ○
- LONG1 ○
- STANDARD ○
- HIGH ○
- S-HIGH ▲

●RDAC-Mode

- MODE1 ○
- MODE2 ○
- MODE3 ▲
- LINEAR ○
- H-LINEAR ▲

●REC Type

- STEREO ○
- MONO ○

●MIDI Time Base

- 192 ○
- 240 ○

1 Phrase Information

- 1.1 Playback Volume (10%--100%) ○
- 1.2 Delay Time (00s00f--59s29f) ◆ Conversion of frames to seconds
- 1.3 Playback Point ▲ Error when playback point is set
- 1.4 Repeat Play ○
- OFF ○
- ON ○
- Repeat (1--99) ×
- Repeat Interval (00m00s--59m59s) ○
- 1.5 Loop Play × Disabled
- 1.6 Fade × Disabled
- 1.7 Control Out ○
- OFF ○
- ON ○
- Offset Time (00m00s--59m59s) ○
- 1.8 MIDI Playback Tempo (5--260) ○
- 1.9 Phrase Name ◆ Up to 11 characters

2 Phrase Combination

- 2.1 Pattern Phrase ▲ Error when pattern phrase is assigned to pattern phrase
- Pattern Phrase Modes ○
- SEQUENTIAL ○
- RANDOM1 ◆ RANDOM
- RANDOM2 ◆ RANDOM
- RANDOM3 ◆ RANDOM
- Interrupt phrase interval (1--25) × Disabled
- Playback sequence (No.001--128) ○
- Assigned phrase (A0001--B1000) ○
- Valid for No. 001 through 100
- Valid for No. 001 through 500
- ▲ Error when 501 or more are present
- Volume (10%--100%) × Disabled
- Interval (00.0s--59.9s) ○
- 2.2 Song phrase ▲ Error when song phrase is present

4 Settings for Card Editing

- 4.1 Card Format ○
- Select Max Phrases ○
- 250 ○
- 500 ○
- 1000 ▲
- 4.5 Card Protect ○
- OFF ○
- ON ◆ Recording Phrase Protection
- 4.6 Card Name ○

5 Settings for Control Input

- 5.1 Control Input Mode ○
- DIRECT PLAY ○
- PROGRAM PLAY ○
- BINARY PLAY ○
- BINARY REC ◆ BINARY1
- 5.2 Direct Play ○
- Normal ○
- First-In ◆ Normal
- Last-In ○
- Sequence ○
- Phrase assignment (1--16) ○
- Assigned phrase ○
- (PLAY,-----,A0001--B1000) ▲ Error when 501 or more are present
- 5.3 Program Play ○
- Program (1--5) ○
- Played back in order ○
- Assigned phrase (A0001--B1000) ○
- Valid for No. 001 through 500
- ▲ Error when 501 or more are present
- 5.4 Binary Play ○
- <Level: Edge> ○
- OFF: OFF ◆ Trigger Mode: Level
- ON: OFF ○ Trigger Mode: Level
- OFF: ON ○ Trigger Mode: Edge
- ON: ON ◆ Trigger Mode: Level
- 5.5 Binary Recording ○
- Phrase select ○
- BINARY1 × Disabled
- BINARY2 × Disabled

Conversion Error Chart

In situations like the ones described below, an error occurs and conversion stops. Take action as described in the remedy, then carry out card conversion again.

6 MIDI settings

- 6.1 MIDI Output (MIDI OUT/THRU)
 - OUT
 - THRU
- 6.2 MIDI Note Map
 - Assigned phrase (A0001–B1000) Valid for No. 001 through 500
 - Error when 501 or more are present
 - Disabled (Always output when MIDI output is set to OUT)
- 6.3 MIDI Note Out
- 6.4 MIDI Channel
- 6.5 Note Trigger
 - Trigger
 - Gate
- 6.6 MIDI Rx Message
 - Note On Velocity Disabled
 - Panpot Disabled
 - Expression Disabled
- 6.7 MIDI Device ID (1–32)
- 6.8 MMC Mode Disabled
- 6.9 MTC
 - Sync Source Disabled
 - Sync Out Disabled
 - MTC Type Disabled
 - MTC Error Level Disabled

7 RS-232C settings

- 7.1 Baud Rate
 - 4800
 - 9600
 - 19200
 - 38400

8 AR-LINK settings

- 8.1 AR-LINK Mode Disabled

9 System settings

- 9.1 Dual Mono Mode
 - OFF (STEREO) Channel Mode: OFF
 - ON (Dual MONO) Channel Mode: ON
- 9.2 Line Thru settings *1
 - <Line Thru:Thru Volume> AR-2000 System Version 1.03 or earlier
 - OFF Line Input Select: OFF
 - ON: When 0% Line Input Select: ON
 - ON: When 1%–100% Line Input Select: ON
 - <Line Thru:Thru Volume> AR-2000 System Version 1.10 or later
 - OFF Line Input Select: Mute
 - ON: When 0% Line Input Select: Mix
 - ON: When 1%–100% Disabled
 - Fade Out, Fade In Disabled
- 9.3 Equalizer Disabled
- 9.4 Output Vol. Thru Disabled
- 9.5 Busy Out *2
 - <Delay Time:Phrase Play:Repeat Play> AR-2000 System Version 1.03 or earlier
 - All settings Disabled (Busy always output)
 - <Delay Time:Phrase Play:Repeat Play> AR-2000 System Version 1.10 or later
 - ON:ON:ON Busy Out: All ON
 - ON:ON:OFF Busy Out: Delay ON
 - ON:OFF:ON Busy Out: All ON
 - ON:OFF:OFF Busy Out: Delay ON
 - OFF:ON:ON Busy Out: Repeat ON
 - OFF:ON:OFF Busy Out: All OFF
 - OFF:OFF:ON Busy Out: Repeat ON
 - OFF:OFF:OFF Busy Out: All OFF
- 9.6 Display Sleep Disabled

*1, *2

Please note that for *1 Line Thru settings and *2 Busy Out, playback results may differ according to the AR-2000 system version. To check the system version of the AR-2000 you're using, switch on the power while holding down the SELECT dial on the front panel. The version information appears on the upper portion of the screen.

▲When there is insufficient space on the destination card for conversion

- If you are carrying out conversion using two cards, the copy-source card and the copy-destination card do not need to be of the same capacity, but card conversion is not possible unless the usable space on the destination card is larger than the used space on the source card.

Action 1: Use a card for the copy destination that has a greater amount of available space than that used on the card-source card.

Action 2: Reduce the space used on the copy-source card, such as by deleting unneeded phrases.

- When you convert a card in AR-2000 format to AR-3000 format, the amount of space used after conversion may increase somewhat. Conversion may not be possible if space is used up or there is little remaining space, even if conversion uses the same card (for single-card conversion) or cards of the same capacity (for two-card conversion).

Action: Reduce the space used on the copy-source card, such as by deleting unneeded phrases.

(What follows are errors that may occur when converting a card in AR-3000 format to AR-2000 format.)

▲When there are phrases recorded using recording settings that do not exist in AR-2000 format

Phrases with the following recording settings cannot be used in AR-2000 format.

- Phrases for which the RDAC grade is S-HIGH
- Phrases for which the RDAC mode is H-LINEAR or MODE3

Action 1: Carry out phrase-editing phrase convert (p. 72) to convert the phrase that caused the error to recording settings that can be used with AR-2000 format.

Action 2: Make a backup on another card, then delete the phrase.

▲When there are phrases for which playback points have been set

When there is a phrase for which playback point phrase information (p. 56) has been set, conversion stops.

Action 1: Carry out phrase-editing phrase truncate.

Action 2: Reset the playback points at both ends of the phrase (resulting in a state in which playback points are not set).

Action 3: Make a backup on another card and delete the phrase.

▲When there is a pattern phrase to which an already-created pattern phrase is assigned.

In the AR-2000 format, a pattern phrase to which a previously created pattern phrase is assigned cannot be used.

Action 1: Re-create the pattern phrase so that previously created pattern phrases are not assigned.

Action 2: Make a backup on another card and delete the pattern phrase.

▲When there are song phrases

In the AR-2000 format, song phrases cannot be used.

Action: Make a backup on another card and delete the song phrase.

▲When there is a phrase at 501 or higher

In the AR-2000 format, only up to 500 phrases can be used.

Action: Copy the phrases to 500 or less, or make a backup on another card and delete the phrase at 501 or higher.

▲When there is a phrase assigned at 501 or higher

When a phrase with the following settings is assigned at 501 or higher, it cannot be used in the AR-2000 format.

- Pattern Phrase
- Direct Playback
- Program Playback

Action: Redo the settings so that no phrases are assigned at 501 or higher.

Recording and Playing MIDI Data (MIDI Phrases)

What Are MIDI Phrases?

You can record and play back MIDI data with the AR-3000R. Sets of MIDI data recorded using the AR are called "MIDI phrases."

MIDI phrases and audio phrases are both treated as phrases in the way.

You can do things like taking MIDI data created on a MIDI sequencer and recording it as a MIDI phrase on the AR-3000R, then send the played-back data to a sound source module or the like to make broadcast announcements.

The AR-3000R saves MIDI data as Format 0 Standard MIDI Files (SMF).

The AR-3000R can only play back Format 0 SMF data.

- * Audio phrases and MIDI phrases cannot be recorded, nor can they be played back at the same time.
- * When recording MIDI phrases, the effective capacity of a card is related not only to the recording time, but also to the density of the MIDI data. Please be aware that when you record MIDI phrases, the possible recording time for any one card will vary depending on the amount of MIDI data that has been generated.

MEMO

Controlling the unit by using MIDI signals is described in another chapter.

Refer to "Controlling the AR-3000R Using MIDI Signals (MIDI Control)" (p. 105).

Connecting Equipment

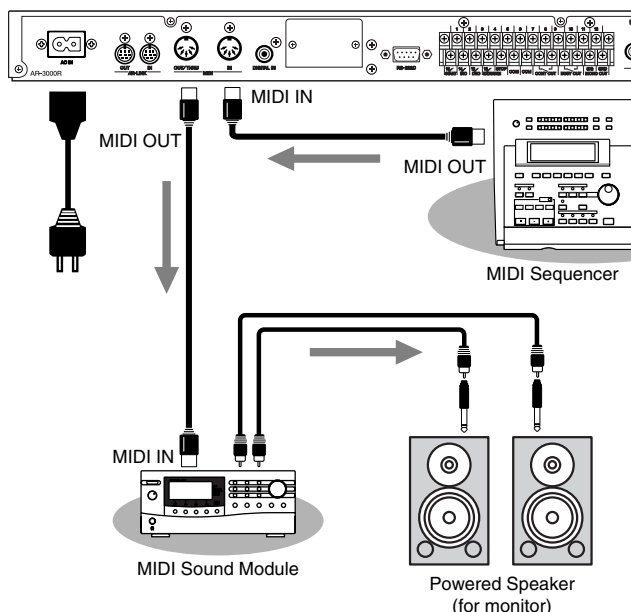

MEMO

During recording or recording standby, this automatically becomes MIDI THRU.



Turning the Power On and Off → p. 24

Unit Settings

Putting the Unit in Recording Standby

Make the correct connections, then turn on the power switch.



Turning the Power On and Off → p. 24

Recording Standby

1. Insert a formatted card into one of the slots.
2. Turn the SELECT dial to choose the phrase number you want to record. To switch between card slots A and B, press the SELECT dial.
 - * You cannot change the phrase number after recording, so be sure to select the phrase number you want to record.
3. Hold down the STOP button and press the PLAY button to go into recording standby.

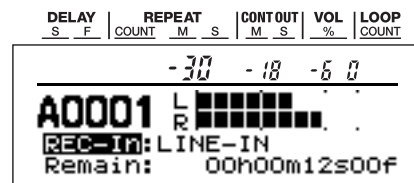

During recording standby, the PLAY indicator and the PAUSE indicator flash in red.

- If you try to re-record a phrase that's already been recorded, a prompt message appears. If you choose "YES" and press the ENTER button, the recorded data for the phrase is deleted and the unit goes into recording standby. If you choose "NO," the unit returns to the normal display.
 - * Please be aware that data deleted here cannot be recovered, even if you cancel recording standby without recording anything.
- When "Card Protect (p. 77)" is set to "ON," recorded phrases are protected and recording is not possible (writing, overwriting, deleting, and editing card data is prohibited).

Selecting the Recording Connector

When you're recording MIDI data, choose "MIDI-IN" as the recording connector.

Procedure for Selecting the Recording Connector

1. Put the unit into recording standby.
2. Turn the SELECT dial to choose the REC-In, then press the dial.
3. Turn the SELECT dial to choose the MIDI-IN, then press the ENTER button.

The screen like the one below appears.

```
A0001 Measure: 1
REC-IN: MIDI-IN Tempo: 120
Remain Byte: 562Kbyte
```

- * Please be aware that if you press the SELECT dial instead of the ENTER button, the setting is not confirmed.
- Next, if you're setting the MIDI time base, go to step 2 of the procedure for setting the MIDI time base.

Setting the MIDI Time Base

The MIDI time base determines the precision with which you can record notes, and differs from one equipment to another. (On some equipment, this is called "resolution.")

Set the time base for the AR-3000R to either 192 or 240, to match the time base of the connected MIDI device.

When the time base of the connected MIDI device is:

24, 48, 96, 192, or 384 → Set the AR-3000R time base to 192

30, 60, 120, 240, or 480 → Set the AR-3000R time base to 240

Procedure for Setting the MIDI Time Base

1. Put the unit into recording standby.
2. Turn the SELECT dial to select "Time Base," then press the dial.
3. Turn the SELECT dial to choose the Time Base (192 or 240), then press the ENTER button.

- * You can set the Time Base only when "MIDI-IN" has been selected as the recording connector.
- * Please be aware that if you press the SELECT dial instead of the ENTER button, the setting is not confirmed.

Starting and Ending Recording

1. Pressing the PLAY or PAUSE button while in recording standby starts recording.

During recording, the PLAY indicator lights up in red.

2. Start playback of the MIDI data.
3. Press the STOP button to end recording.

NOTE

- Some MIDI sequencers output the setup data for the MIDI sound module (data describing the tones for each part, the volume, effects, etc.) **when the song is selected**, and it may be impossible to record the MIDI information correctly when recording is started on the AR-3000R after song selection. Should this occur, first start recording on the AR-3000R, and after that initiate song selection and the start of playback on the MIDI sequencer.
- In MIDI recording on the AR-3000R, the tempo when recorded is assumed to be 120. (Tempo information is not stored.)
- You can't change a phrase number later, so be sure to choose the phrase number you want to record to, and then record.
- * Recording cannot span two cards inserted in the slots. When the free space on one card is used up, recording ends automatically.

HINT

Starting and Stopping Recording Through MIDI Playback

With the AR-3000R, you can start recording when a start message is received from another MIDI device, and stop recording when a stop message is received during recording. During recording standby, recording starts when a System Realtime start message (FAH) is received, and stops when a stop message (FCH) is received.

During playback, start (FAH), stop (FCH), and timing clock (F8H) messages are sent.



What Is a Timing Clock?

This is MIDI information used when synchronizing a number of instruments using MIDI. The playback device sends clock messages at intervals that correspond to its own tempo, and the receiving device operates in accordance with those messages.



MIDI Implementation and MIDI Implementation Chart → p. 139 through p. 145

Playback of MIDI Phrases

Selection of MIDI Output (OUT/THRU)

This changes the function of the MIDI output connector. Here, select OUT.

OUT: This sends out MIDI information from the unit. Select this when you want to play back MIDI phrases or send Exclusive (SysEx) messages.

THRU: This takes MIDI information from MIDI IN and sends it out unchanged. MIDI signals from the unit are not output.

Procedure for Setting MIDI Output

1. Press the MODE button. The MODE indicator lights up.
2. Use the SELECT dial to choose "6.1 MIDI Output," then press the dial.
3. Turn the SELECT dial to choose the MIDI Output (OUT), then press the dial.

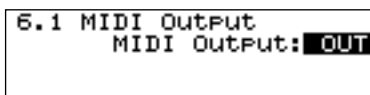

4. When the prompt appears on the screen, press the ENTER button to enable the setting. To quit without making the settings, use the SELECT dial to choose "NO," then press the ENTER button.

When you're finished making the setting, the display returns to the setting item selection screen.

5. Press the MODE button.

This ends the setting process and returns you to the usual screen.

* If you press the MODE button while making settings, a message asking you to confirm that you want to exit the setting process appears. Note that if you choose "YES", then press the ENTER button, you are returned to the usual screen, and all setting changes you've made up to that point will be discarded.

Setting the Playback Tempo

This sets the speed for playback of MIDI phrases in beats per minute (a tempo of from 5 to 260). The setting is made for individual phrases.

* In MIDI recording on the AR-3000R, the tempo when recorded is assumed to be 120. (Tempo information is not stored.)



The setting for the MIDI playback tempo is made with a phrase setting. Refer to "Changing the Playback Tempo for MIDI Phrases (MIDI Playback Tempo)" (p. 60).

Playback Procedures

Manual Playback

1. Insert a card containing recorded information into a slot.
2. Turn the SELECT dial to choose the phrase number to play. To switch between card slots A and B, press the SELECT dial.
3.
 - Press the PLAY button, and the phrase starts playing back. During playback of the phrase, the PLAY indicator lights up in green.
 - Pressing the STOP button ends playback.
 - During playback, you can choose the next song to play (without stopping the phrase being played) by turning the SELECT dial.

* Please be aware that you cannot pause a MIDI phrase.

Playback by Control Input

You can perform playback by control input and other means, just as you can for audio phrases.



Controlling the AR-3000R from an External Device → p. 85

Controlling the AR-3000R from an External Device (Control Input Terminals)

You can control the unit from an external device by using the input terminals, among the screw-on control terminals on the unit's rear panel.

This chapter describes how to connect external equipment and make the settings on the AR-3000R.

MEMO

To confirm phrases when selecting a phrase, you can use the PLAY and STOP buttons to play and stop phrases, and the PAUSE button to pause phrases. Note that you cannot change settings during phrase playback.

What Is No-voltage/Make-contact?

This is a contact that makes starting possible simply by connecting two lines to the control input terminals and shorting their ends. This is a general-use method that lets you create start systems easily using only a switch and without any need for a power source, enabling easy use for a variety of applications.

You can control recording and playback on the AR-3000R by on and off signals input from an external device through the no-voltage/make-contact or open collector circuit.

The range of situations where you can use the unit can be expanded by connecting infrared sensors, external-start connectors such as switches, relays, and timers, and the like to the unit.

The AR-3000R can help simplify installation operations by making the starting-side contact hot and sharing the ground as the common (COM) port.



Also refer to "Examples of Usage and Connection for the AR-3000R" (p. 19) for more examples of usage of the control input and output terminals.



For information about the specifications of the control input and output terminals, refer to "Specifications of the Control Input/Output Terminals" (p. 137).

Important Notes on Using the Control Input and Output Terminals

- * The control input and output terminals cannot be used to switch the power to the AR unit on or off.
- * The two common (COM) ports are connected internally, so you can achieve operation by making the connection to either one. At times such as when connecting more than one AR control port to a single make contact, interconnect one COM port from each AR. However, do not intermix this unit with other AR series devices. Doing so may result in unstable operation.

NOTE

When making connections to the ports, be careful not to lose the removed screws. Place the screws out of the reach of small children. If a screw is accidentally swallowed, immediately consult a physician.

Types of Control Input Playback

The varieties of control input playback are direct playback (p. 86), program playback (p. 89), and binary playback (p. 92).

The three playback methods yield the following nine types of operational specifications according to their settings. Choose the one that matches your usage conditions.

- Direct Playback (NORMAL)
- Direct Playback (FIRST-IN)
- Direct Playback (LAST-IN)
- Direct Playback (SEQUENCE)
- Program Playback
- Binary Playback (Level: OFF; Edge: OFF)
- Binary Playback (Level: ON; Edge: OFF)
- Binary Playback (Level: OFF; Edge: ON)
- Binary Playback (Level: ON; Edge: ON)

* Different types of playback cannot be carried out at the same time.

Operational Specifications for Control Input Playback

	When new control signals are input during playback of a phrase	When control signals are input continuously
Direct Play		
Normal	When priority is high, quits and plays back the phrase specified later. No effect when priority is low or when the number is the same.	Repeated
First-In	Disabled	Repeated
Last-In	Quits and plays back the phrase specified later.	Repeated
Sequence	Stored in memory (cued). After phrase playback finishes, sequential start. Up to 100 can be cued.	Played back once only
Program Play		
	Disabled	Playback in assigned sequence, repeated playback within the program. Exchange advances to the next program.
Binary Play		
Level: OFF Edge: OFF	Disabled	Played back once only
Level: ON Edge: OFF	Disabled	Repeated
Level: OFF Edge: ON	Quits and plays back the phrase specified later.	Played back once only
Level: ON Edge: ON	Quits and plays back the phrase specified later.	Repeated

Type of Control Input Recording

There is one type of control input recording: Binary Recording (p. 98).

Assigning a Phrase to a Port and Playing It Back (Direct Playback)

What Is Direct Playback?/Uses and Applications

By inputting control signals directly to Port Nos. 1 through 16, you can play back the phrases assigned to the port numbers. You can play back up to 16 phrases. You need to assign the phrases you want to Port Nos. 1 through 16 ahead of time.

This is handy when you want to directly specify the phrases you want using switches, relays, sensors, and the like.

Port No.	1	2	3	4	5	...	16
Phrase	A0002	A0010	B0008	A0021	B0050	...	A0050

Connecting External Equipment

Ports Used for Direct Play

“1 through 16”: Inputting a control signal directly to the port having the number corresponding to the phrase starts playback of the phrase.

“STOP”: This stops phrase playback.

Set to “ON” by shorting the above-mentioned port and “COM (common).”

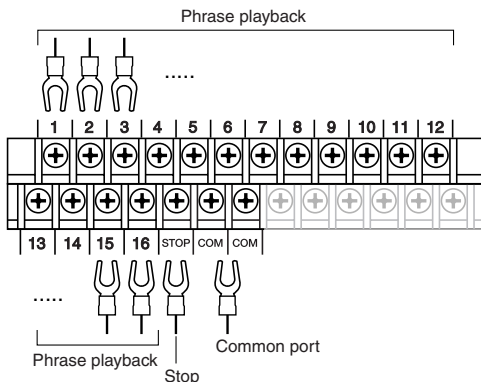

Turning the Power On and Off → p. 24

Operational Specifications for Direct Playback

Basic Operation of Direct Playback

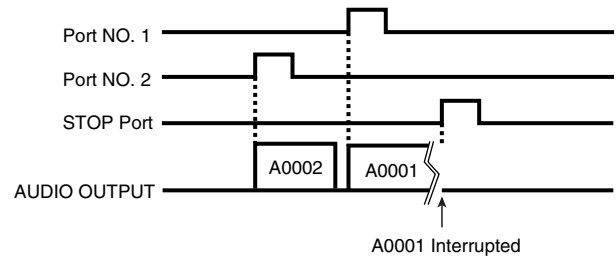

Playback:

Input a control signal to a port from 1 to 16.

→ This plays the phrase assigned to the port.

Stop:

Input a control signal to the Stop port.

→ This stops phrase playback.

Also, Direct playback includes normal playback, First-In playback, Last-In playback, and sequence playback.

Choose the one that matches your usage conditions.



Also refer to “Operational Specifications of Control Input Playback” (p. 85).

Normal Playback

Input made to a port having higher priority takes precedence, and will result in earlier playback.

Port No. 1 has the highest priority, with the priority decreasing as the port number increases.

Priority (High) Port No. 1 → 2 → 3 → ... → 16 (Low)

When a control signal is input to a high-priority port during phrase playback, playback of the current phrase is stopped, and playback of the specified phrase then begins.

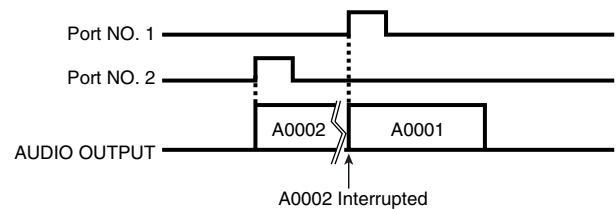

No action results if a control signal is input to a low-priority port (or the same numbered port) during phrase playback.

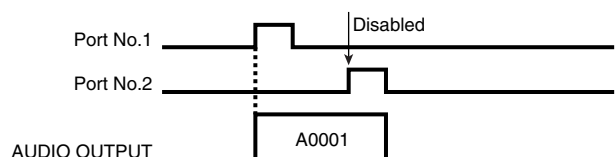

Playback is repeated while the control signal is continuously input.

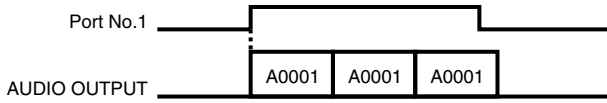

First-In Playback

The phrase played back earlier is given precedence in playback.

During phrase playback, even when a new START signal is input, it is disregarded.

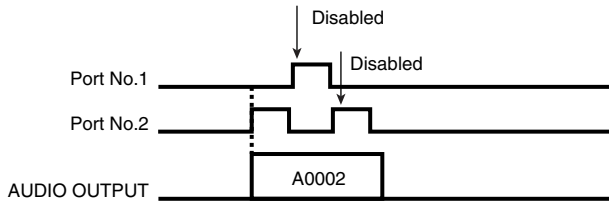

Playback is repeated while the control signal is continuously input.

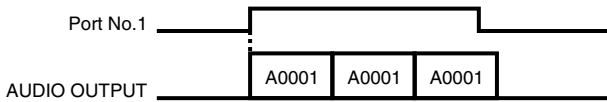

Last-In Playback

The control signal that is input later is given precedence in playback.

During phrase playback, when a different START signal is newly input, playback of the current phrase is stopped, and playback of the specified phrase begins.

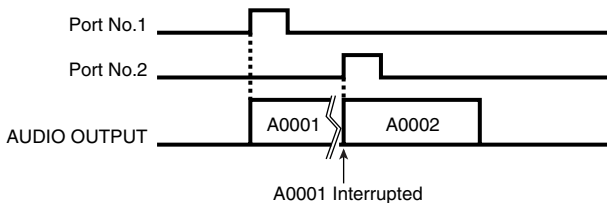

Playback is repeated while the control signal is continuously input.

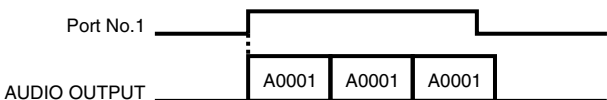

Sequence Playback

When a new control signal is input during phrase playback, the new phrase is then stored (queued).

When playback of the current phrase is finished, the subsequently specified phrase is played back.

A maximum of 100 phrases can be stored (queued).

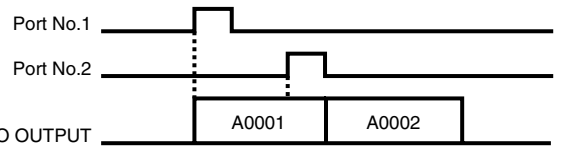

Even when control signals are input continuously, playback is conducted one time only and then ends.

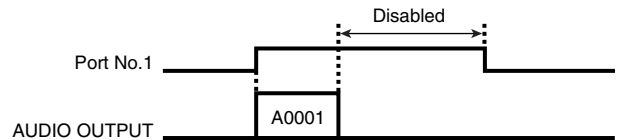

AR-3000R Settings

NOTE

If a card in AR-2000 format is inserted in either slot A or B (or both), the AR-3000R can be used only for playback, and it is not possible to record phrases or make any settings (except for card conversion). Also, if you insert a card in AR-2000 format into slot A or B (or both) while making settings (except for card conversion), operation will halt with an error message, and cannot be resumed until such cards are removed. To record or edit cards in AR-2000 format on the AR-3000R, follow the steps in "Card Convert" (p. 78).

Selecting the Control Input Mode

Select "DIRECT PLAY" from the control input modes (DIRECT PLAY/PROGRAM PLAY/BINARY PLAY/BINARY REC).

* You cannot achieve control input playback merely by connecting a device to the port. Be sure to set the control input mode to match the method used for connecting to the ports.

Procedure for Setting the Control Input Mode

1. Press the MODE button.
The MODE indicator lights up.
2. Use the SELECT dial to choose "5.1 Control Input Mode," then press the dial.
3. Turn the SELECT dial to choose "DIRECT PLAY," then press the dial.

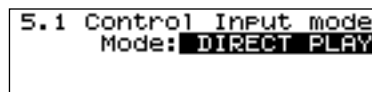

Controlling the AR-3000R from an External Device

4. When the prompt appears on the screen, press the ENTER button to enable the settings.

To quit without making the settings, use the SELECT dial to choose "NO," then press the ENTER button.

Once the settings have been made successfully, you're returned to the setting item selection screen.

5. Press the MODE button.

This ends the setting process and returns you to the usual screen.

* If you press the MODE button while making settings, a message asking you to confirm that you want to exit the setting process appears. Note that if you choose "YES," then press the ENTER button, you are returned to the usual screen, and all setting changes you've made up to that point will be discarded.

Selecting the Direct Playback Method

Select the Direct Playback Method (NORMAL/FIRST-IN/LAST-IN/ SEQUENCE) to be used.



"Operational Specifications for Direct Playback" → p. 86

Procedure for Setting the Direct Playback Method

1. Press the MODE button.

The MODE indicator lights up.

2. Use the SELECT dial to choose "5.2 Direct Play," then press the dial.

3. Turn the SELECT dial to choose the Direct Playback system (NORMAL, FIRST-IN, LAST-IN, or SEQUENCE), then press the dial.

```
5.2 Direct Play
Direct Play: NORMAL
No.1 A0001
```

- If making the settings in "Assigning Phrases to the Ports," proceed to Step 4 in the procedure for assigning the phrases.
 - To quit making settings, press the ENTER button.
4. When the prompt appears on the screen, press the ENTER button to enable the settings.

To quit without making the settings, use the SELECT dial to choose "NO," then press the ENTER button.

Once the settings have been made successfully, you're returned to the setting item selection screen.

5. Press the MODE button.

This ends the setting process and returns you to the usual screen.

* If you press the MODE button while making settings, a message asking you to confirm that you want to exit the setting process appears. Note that if you choose YES, then press the ENTER button, you are returned to the usual screen, and all setting changes you've made up to that point will be discarded.

Assigning Phrases to the Ports

Assign phrases to control input Port Nos. 1 through 16.

If not assigning a phrase to a port, select "----."

NOTE

While you can select phrases from Card A as well as Card B, note that playback will not work properly if the card inserted when the phrase was registered is not inserted at the time of playback (if the phrase is not saved, the playback signal is disregarded).

Settings When Formatting Cards (in Slot A)

Port No.	1	2	3	4	5	...	16
Phrase	A0001	A0002	A0003	A0004	A0005	...	A0016

HINT

By assigning "PLAY" instead of a phrase, you can obtain the same functions from that port as you do using the PLAY button on the front panel.

<During Direct Playback>

By inputting a control signal to the port to which "PLAY" is assigned, you can play back the phrase indicated in the display. This is convenient when you want to use an external device to start playback of phrases selected with the SELECT dial.

You can also stop playback using the STOP port.

<While in Phrase Record Standby>

When recording phrases, you can use the control input terminals to start and stop recording (for more on recording methods, please read "Recording Audio" (p. 40) as well).

When in recording standby, if the port to which "PLAY" is assigned is set to "ON," recording will begin. This is convenient when you want to start recording remotely, using an external device.

You can also stop recording using the Stop port.

* However, this method cannot be used for switching to recording standby, even when control signals are sent to both the port to which "PLAY" is assigned and the STOP port.

Procedure for Assigning Phrases

1. Press the MODE button.

The MODE indicator lights up.

2. Use the SELECT dial to choose "5.2 Direct Play," then press the dial.

3. Press the SELECT dial to advance the input location (highlighted) to "No. 1."

4. Turn the SELECT dial to choose the number of the control input port that is to be set, then press the dial.

```

5.2 Direct Play
Direct Play:  NORMAL
No.1         A0001
  
```

- **Nos. 1-16:** Port Nos. 1 through No. 16
 - **END:** This quits making the settings.
 - **RESET:** Restores the settings at the time the card was formatted.
 - **CLEAR:** Erases all settings.
5. Turn the SELECT dial to choose the card containing the phrase you want to assign to the port, then press the dial.

```

5.2 Direct Play
Direct Play:  NORMAL
No.1         B0001
  
```

- **PLAY:** Causes this connector to perform the same action as that resulting from pressing the PLAY button on the front panel.
- **-----:** Selected when no phrase is set to the control input port.

Turn the SELECT dial to choose the phrase to assign to the port, then press the dial.

6. Repeat steps 4 and 5 to assign the rest of the phrases.
7. To quit assigning phrases, turn the SELECT dial in step 4 to choose "END," then press the dial.

```

5.2 Direct Play
Direct Play:  NORMAL
END
  
```

8. When the prompt appears on the screen, press the ENTER button to enable the settings.

To quit without making the settings, use the SELECT dial to choose "NO," then press the ENTER button.

Once the settings have been made successfully, you're returned to the setting item selection screen.

9. Press the MODE button.

This ends the setting process and returns you to the usual screen.

* While making the settings, you can go back to the previous entry position (highlighted) by using the PAUSE (BACK) button.

* If you press the MODE button while making settings, a message asking you to confirm that you want to exit the setting process appears. Note that if you choose "YES," then press the ENTER button, you are returned to the usual screen, and all setting changes you've made up to that point will be discarded.

Playing Back Phrases in the Order They Are Selected (Program Playback)

What is Program Playback?/ Uses and Applications

You can have the group of preset phrases play back in the order they are selected by inputting a control signal to the START port.

With program playback, you can register up to a maximum of 100 phrases in each of the five patterns of Programs 1 through 5.

Since the order and duration of the phrases is predetermined, this is a convenient option when you have only one contact, such as a timer or switch, with which to trigger this action.

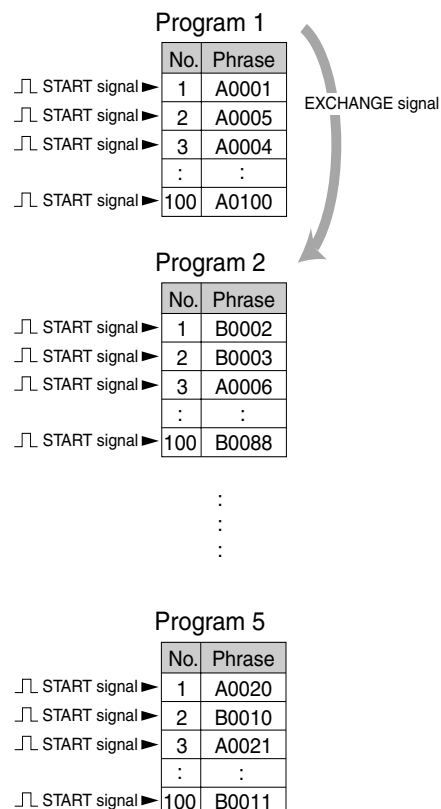

Connecting External Equipment

Ports Used in Program Playback

“START”: Plays back phrases in the order set in program playback.

“STOP”: This stops phrase playback.

“INC” (Increment): Advances through the program playback order.

“DEC” (Decrement): Goes back through the previous phrases in the program playback order.

“EXCHANGE”: Advances through the cycle of the Programs 1 through 5 (1-2-3-4-5-1-2...). In this case, playback begins from the first phrase selected in the program to which you have switched.

* If no settings are made for Programs 2 through 5, playback begins from the first phrase set in Program 1.

Set to “ON” by shorting the above-mentioned port and “COM (common).”

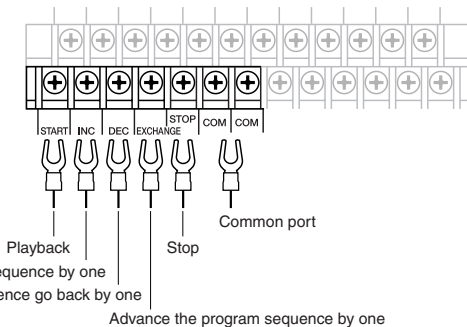

Turning the Power On and Off → p. 24

Operational Specifications for Program Playback

When a one-shot control signal is input from a timer or similar device, a single registered phrase is played back.

* If there is no registered phrase saved, the next registered phrase is played back.

When consecutive signals are input, phrases are played back in succession in the order registered in the program.

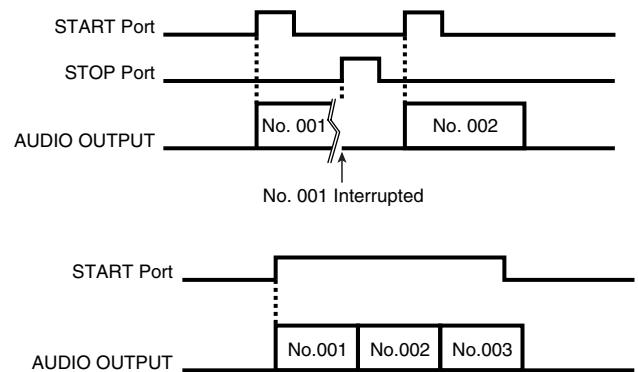

Playback:

Input a control signal to the START port.

→ Phrases are played back in accord with the registered program playback order.

Stop:

Input a control signal to the STOP port.

→ This stops phrase playback.

Advancing in the Playback Sequence:

Input a control signal to the INC (Increment) port.

→ This advances through the program playback order one phrase at a time.

Going Through the Playback Sequence in Reverse Order:

Input a control signal to the DEC (Decrement) port.

→ This causes the phrases to go back through the program playback order one phrase at a time.

Advancing Through Programs 1 Through 5:

Input a control signal to the EXCHANGE port.

→ This advances through Programs 1 Through 5 (1-2-3-4-5-1-2-...).

Playback begins from the first phrase selected in the program to which you have switched.

* If no settings are made in Programs 2 through 5, playback begins from the first phrase set in Program 1.

During phrase playback, even when a new START signal is input, it is disregarded.

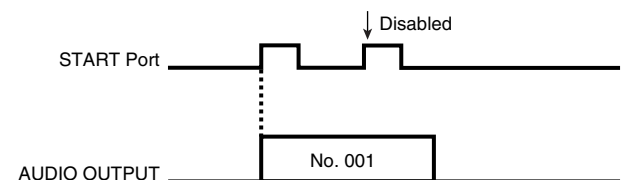

If input of START signals continues when the end of the last phrase in Program 1 is reached, playback then continues with the first phrase in Program 1. To advance to Program 2, input a control signal to the “EXCHANGE” port.

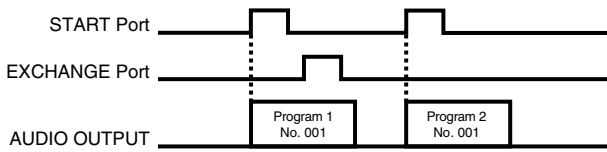

However, if no settings are made for Programs 2 through 5 when a control signal is input to the “EXCHANGE” port, playback continues after returning to the beginning in Program 1 (Reset operation).

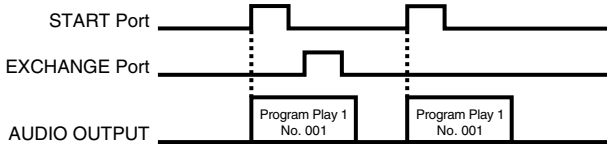

Also refer to “Operational Specifications of Control Input Playback” (p. 85).



Important Note Regarding Power Outages and Similar Situations

If due to a blackout or other cause the power to the AR-3000R is cut during program playback, the program playback is reset when the power is restored. In such instances, input control signals to the INC, DEC, and EXCHANGE ports to restore the program playback order.

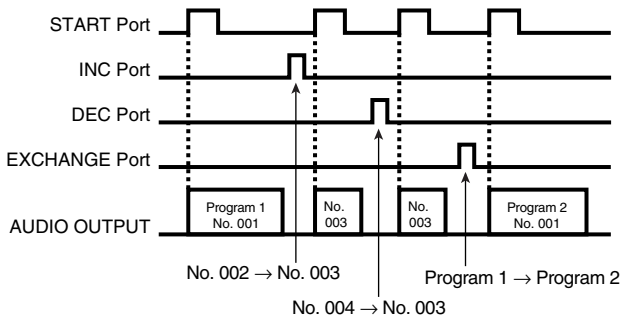

Display Indications During Program Playback

During program playback, the following appears in the display.

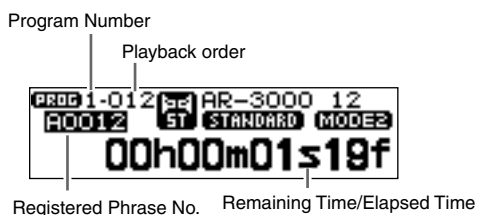

AR-3000R Settings



If a card in AR-2000 format is inserted in either slot A or B (or both), the AR-3000R can be used only for playback, and it is not possible to record phrases or make any settings (except for card conversion). Also, if you insert a card in AR-2000 format into slot A or B (or both) while making settings (except for card conversion), operation will halt with an error message, and cannot be resumed until such cards are removed. To record or edit cards in AR-2000 format on the AR-3000R, follow the steps in “Card Convert” (p. 78).

Selecting the Control Input Mode

Select “PROGRAM PLAY” from the control input modes (DIRECT PLAY/PROGRAM PLAY/BINARY PLAY/BINARY REC).

- * You cannot achieve control input playback merely by connecting a device to the port. Be sure to set the control input mode to match the method used for connecting to the ports.

Procedure for Setting the Control Input Mode

1. Press the MODE button.

The MODE indicator lights up.

2. Use the SELECT dial to choose “5.1 Control Input Mode,” then press the dial.

3. Turn the SELECT dial to choose “PROGRAM PLAY,” then press the dial.



4. When the prompt appears on the screen, press the ENTER button to enable the settings.

To quit without making the settings, use the SELECT dial to choose “NO,” then press the ENTER button.

Once the settings have been made successfully, you’re returned to the setting item selection screen.

5. Press the MODE button.

This ends the setting process and returns you to the usual screen.

- * If you press the MODE button while making settings, a message asking you to confirm that you want to exit the setting process appears. Note that if you choose “YES,” then press the ENTER button, you are returned to the usual screen, and all setting changes you’ve made up to that point will be discarded.

Controlling the AR-3000R from an External Device

Registering Phrases

Register the phrases in the program playback order. Up to a maximum of 100 phrases can be registered in each of the five patterns of Programs 1 through 5.

NOTE

While you can select phrases from Card A as well as Card B, note that playback will not work properly if the card inserted when the phrase was registered is not inserted at the time of playback (if the phrase is not saved, the next phrase is sought and then played back).

Settings When Formatting Cards (in Slot A)

Program 1

No.	Phrase
1	A0001
2	A0002
3	A0003
:	:
100	A0100

Program 2–5: No setting has been supplied.

Procedure for Registering Phrases

1. Press the MODE button.

The MODE indicator lights up.

2. Use the SELECT dial to choose "5.3 Program Playback," then press the dial.
3. Turn the SELECT dial to choose the Program No. where you want to make the setting (1 through 5), then press the dial.

```
5.3 Program Play
      Program No.:1
No.001      A0001
```

4. Turn the SELECT dial to choose the playback sequence, then press the dial.
 - **Nos. 001-100:** Playback order
 - **END:** Finishes the setting process.
 - **RESET:** Restores the settings the card had when formatted.
 - **CLEAR:** Erases all settings.
5. Turn the SELECT dial to choose the card containing the phrase you want to store, then press the dial.

```
5.3 Program Play
      Program No.:1
No.001      00001
```

6. Turn the SELECT dial to choose the phrase you want to store, then press the dial.

7. Repeat steps 4 and 5 to store more phrases.
8. To cancel the save process, then in step 4, turn the SELECT dial to choose "END," then press the dial.

```
5.3 Program Play
      Program No.:1
      END
```

9. When the prompt appears on the screen, press the ENTER button to enable the settings.

To quit without making the settings, use the SELECT dial to choose "NO," then press the ENTER button.

Once the settings have been made successfully, you're returned to the setting item selection screen.

10. Press the MODE button.

This ends the setting process and returns you to the usual screen.

* While making the settings, you can go back to the previous entry position (highlighted) by using the PAUSE (BACK) button.

* If you press the MODE button while making settings, a message asking you to confirm that you want to exit the setting process appears. Note that if you choose "YES," then press the ENTER button, you are returned to the usual screen, and all setting changes you've made up to that point will be discarded.

Specifying Phrase Numbers in Binary Notation (Binary Playback)

What is Binary Playback?/Uses and Applications

In binary playback, phrases are selected by means of binary (Base 2) control signal input to the Port No. 1 through 11, with the selected phrases played back when control signals are input to the START port. You can select and play back up to a maximum of 2000 phrases.

This allows all phrases to be specified with control signals (from a switch or other ON/OFF signal device) without the use of computers or other complicated equipment.

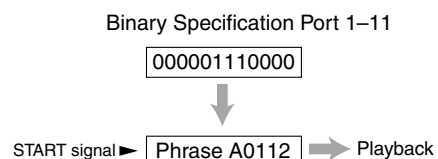

* To conduct binary playback, you will need to obtain a control device capable of generating binary signals.

* Input of binary specifications should be completed in no more than 50 milliseconds.

Connecting External Equipment

Terminals Used in Binary Playback

“1-10”: Phrases are specified in binary format using combinations of 0 (OFF) and 1 (ON).

“11”: 0 (OFF) and 1 (ON) are used to select Card A and Card B.

“START”: Plays back phrases.

“STOP”: This stops phrase playback.

Set to “ON” by shorting the above-mentioned port and “COM (common).”

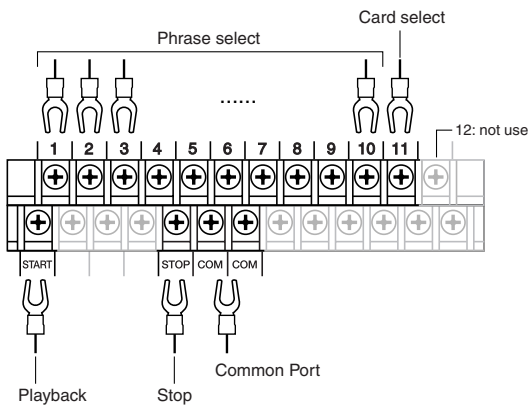

Turning the Power On and Off → p. 24



Even without connecting to all ten ports used for making the binary specifications, you can still conduct binary playback. The number of phrases that can be specified is determined by the formula “two to the nth power minus one” (with “n” being the number of connectors used).

Example:

Using three timers or other such devices capable of outputting the necessary signals gives two to the third power minus one (i.e., $2^3 - 1 = 7$), meaning you can specify the seven phrases 001 through 007.

However, if Port No. 11 is not connected, only “OFF” is enabled, leaving Card A as the only card that may be selected.

Start signals feature other special requirements.

Operational Specifications of Binary Playback

Basic Operation of Binary Playback

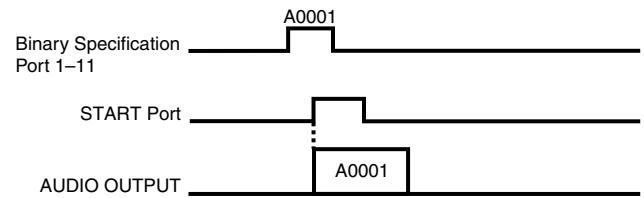

Playback:

Specify the phrases using combinations of signals to Port Nos. 1 through 10 and 0 (OFF) and 1 (ON) of Port No. 11, and input a control signal to the “START” port.

→ This plays back the specified phrase.

Stop:

Input a control signal to the Stop port.

→ This stops phrase playback.

In addition, in binary playback you can use combinations of playback trigger (Level/Edge) ON and OFF to achieve the four types of playback shown below. Set it to match your usage conditions.



Also refer to “Operational Specifications of Control Input Playback” (p. 85).

Level: OFF, Edge: OFF

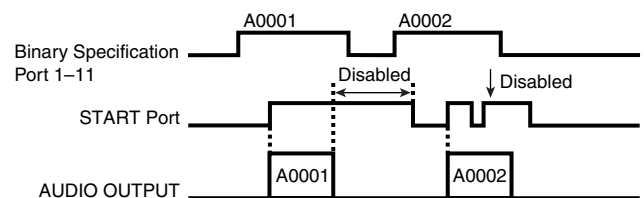

The binary-specified phrase is played back only once.

Newly input START signals during playback of a phrase are disregarded.

Even when START signals are input continuously, the phrase is played back only once and stopped. Since a phrase is played back by the instrument detecting the start when the port switches on from the off status, be sure to make the control signal to the START port OFF after playback of the phrase is finished.

Level: ON, Edge: OFF

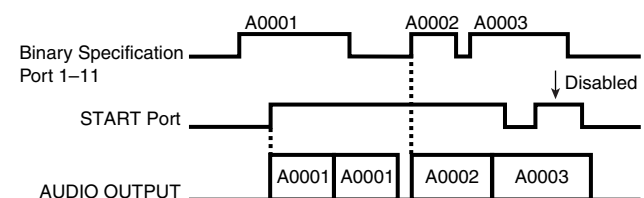

Controlling the AR-3000R from an External Device

The binary-specified phrase is played back repeatedly.

Phrases are played back repeatedly as long as the START signal is input continuously.

With START signals being input continuously, playback of phrases may be started by binary specification.

When the Start port control signal is changed to OFF, playback tops after completion of the phrase currently being played.

Newly input START signals during playback of a phrase are disregarded.

Level: OFF, Edge: ON

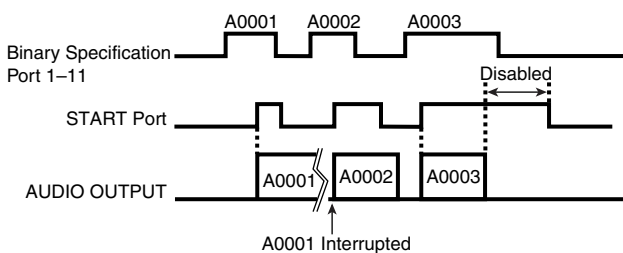

The binary-specified phrase is played back only once.

When a START signal is input again during playback of a phrase, the phrase currently being played back is stopped, and playback of the specified phrase begins.

Even when START signals are input continuously, the phrase is played back only once and then stopped. Since a phrase is played back by the instrument detecting the start when the port switches on from the off status, be sure to make the control signal to the Start connector OFF after playback of the phrase is finished.

Level: ON, Edge: ON

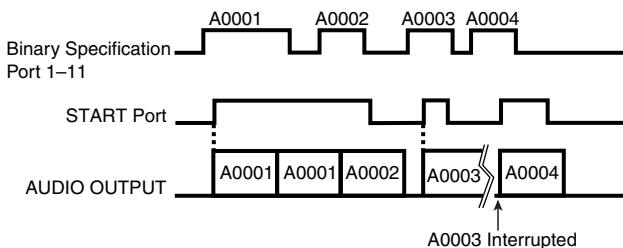

The binary-specified phrase is played back repeatedly.

Phrases are played back repeatedly as long as the START signal is input continuously.

With START signals being input continuously, playback of phrases may be started by binary specification.

When the Start port control signal is changed to OFF, playback tops after completion of the phrase currently being played.

When a START signal is input again during playback of a phrase, the phrase currently being played back is stopped, and playback of the specified phrase begins.

AR-3000R Settings

NOTE

If a card in AR-2000 format is inserted in either slot A or B (or both), the AR-3000R can be used only for playback, and it is not possible to record phrases or make any settings (except for card conversion). Also, if you insert a card in AR-2000 format into slot A or B (or both) while making settings (except for card conversion), operation will halt with an error message, and cannot be resumed until such cards are removed. To record or edit cards in AR-2000 format on the AR-3000R, follow the steps in "Card Convert" (p. 78).

Selecting the Control Input Mode

Select "BINARY PLAY" from the control input modes (DIRECT PLAY/PROGRAM PLAY/BINARY PLAY/BINARY REC).

- * You cannot achieve control input playback merely by connecting a device to the port. Be sure to set the control input mode to match the method used for connecting to the ports.

Procedure for Setting the Control Input Mode

1. Press the MODE button.

The MODE indicator lights up.

2. Use the SELECT dial to choose "5.1 Control Input Mode," then press the dial.
3. Turn the SELECT dial to choose "BINARY PLAY," then press the dial.

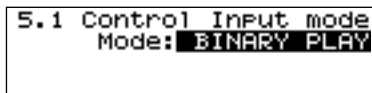

4. When the prompt appears on the screen, press the ENTER button to enable the settings.

To quit without making the settings, use the SELECT dial to choose "NO," then press the ENTER button.

Once the settings have been made successfully, you're returned to the setting item selection screen.

5. Press the MODE button.

This ends the setting process and returns you to the usual screen.

- * If you press the MODE button while making settings, a message asking you to confirm that you want to exit the setting process appears. Note that if you choose "YES," then press the ENTER button, you are returned to the usual screen, and all setting changes you've made up to that point will be discarded.

Playback Trigger Settings (Level/Edge)

Use combinations of playback trigger (Level/Edge) ON and OFF to achieve the four types of playback shown below.

- Level: OFF; Edge: OFF
- Level: ON; Edge: OFF
- Level: OFF; Edge: ON
- Level: ON; Edge: ON



Operational Specifications of Binary Playback → p. 93

Procedure for Setting the Playback Triggers

1. Press the MODE button.

The MODE indicator lights up.

2. Use the SELECT dial to choose "5.4 Binary Play," then press the dial.

3. Turn the SELECT dial to choose the playback trigger Level (OFF or ON), then press the ENTER button.

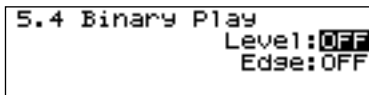

4. Turn the SELECT dial to choose the playback trigger Edge (OFF or ON), then press the dial.

5. When the prompt appears on the screen, press the ENTER button to enable the settings.

To quit without making the settings, use the SELECT dial to choose "NO," then press the ENTER button.

Once the settings have been made successfully, you're returned to the setting item selection screen.

6. Press the MODE button.

This ends the setting process and returns you to the usual screen.

- * While making the settings, you can go back to the previous entry position (highlighted) by using the PAUSE (BACK) button.
- * If you press the MODE button while making settings, a message asking you to confirm that you want to exit the setting process appears. Note that if you choose "YES," then press the ENTER button, you are returned to the usual screen, and all setting changes you've made up to that point will be discarded

To Specify Phrases With Binary Signals

Example: Specifying Phrase A0015 (Card: A, Phrase #: 0015)

1. Convert the phrase number to a binary signal number.

"0" (OFF)

"1" (ON)



Phrase Number/Binary Signal Correspondence Table (p. 96)

The phrase number "0015" becomes the binary signal "0000011111."

2. Select Card A or B with and ON or OFF control signal to Port No. 11.

Card A: "0" (OFF)

Card B: "1" (ON)

* If there is no connection to Port No. 11, this is the same as "OFF," and Card A is selected.

With the above steps, Phrase No. A0015 is converted to:

Port No.	→	1	2	3	4	5	6	7	8	9	10
Input signal	→	1	1	1	1	0	0	0	0	0	0
		Phrase No. (Binary)									Card

NOTE

- Note that the direction of the phrase numbers (binary) and port numbers are reversed.
- While you can select phrases from Card A as well as Card B, note that playback will not work properly if the card inserted when the phrase was registered is not inserted at the time of playback (if the phrase is not saved, the playback signal is disregarded).
- Input of binary specifications should be completed in no more than 50 milliseconds.

Phrase Number/Binary Signal Correspondence Table

Phrase No.	Port No. 10987654321	Phrase No.	Port No. 10987654321	Phrase No.	Port No. 10987654321	Phrase No.	Port No. 10987654321	Phrase No.	Port No. 10987654321
0001	0000000001	0101	0001100101	0201	0011001001	0301	0100101101	0401	0110010001
0002	0000000010	0102	0001100110	0202	0011001010	0302	0100101110	0402	0110010010
0003	0000000011	0103	0001100111	0203	0011001011	0303	0100101111	0403	0110010011
0004	0000000100	0104	0001101000	0204	0011001100	0304	0100110000	0404	0110010100
0005	0000000101	0105	0001101001	0205	0011001101	0305	0100110001	0405	0110010101
0006	0000000110	0106	0001101010	0206	0011001110	0306	0100110010	0406	0110010110
0007	0000000111	0107	0001101011	0207	0011001111	0307	0100110011	0407	0110010111
0008	0000001000	0108	0001101100	0208	0011010000	0308	0100110100	0408	0110011000
0009	0000001001	0109	0001101101	0209	0011010001	0309	0100110101	0409	0110011001
0010	0000001010	0110	0001101110	0210	0011010010	0310	0100110110	0410	0110011010
0011	0000001011	0111	0001101111	0211	0011010011	0311	0100110111	0411	0110011011
0012	0000001100	0112	0001110000	0212	0011010100	0312	0100111000	0412	0110011100
0013	0000001101	0113	0001110001	0213	0011010101	0313	0100111001	0413	0110011101
0014	0000001110	0114	0001110010	0214	0011010110	0314	0100111010	0414	0110011110
0015	0000001111	0115	0001110011	0215	0011010111	0315	0100111011	0415	0110011111
0016	0000010000	0116	0001110100	0216	0011011000	0316	0100111100	0416	0110100000
0017	0000010001	0117	0001110101	0217	0011011001	0317	0100111101	0417	0110100001
0018	0000010010	0118	0001110110	0218	0011011010	0318	0100111110	0418	0110100010
0019	0000010011	0119	0001110111	0219	0011011011	0319	0100111111	0419	0110100011
0020	0000010100	0120	0001111000	0220	0011011100	0320	0101000000	0420	0110100100
0021	0000010101	0121	0001111001	0221	0011011101	0321	0101000001	0421	0110100101
0022	0000010110	0122	0001111010	0222	0011011110	0322	0101000010	0422	0110100110
0023	0000010111	0123	0001111011	0223	0011011111	0323	0101000011	0423	0110100111
0024	0000011000	0124	0001111100	0224	0011100000	0324	0101000100	0424	0110101000
0025	0000011001	0125	0001111101	0225	0011100001	0325	0101000101	0425	0110101001
0026	0000011010	0126	0001111110	0226	0011100010	0326	0101000110	0426	0110101010
0027	0000011011	0127	0001111111	0227	0011100011	0327	0101000111	0427	0110101011
0028	0000011100	0128	0010000000	0228	0011100100	0328	0101001000	0428	0110101100
0029	0000011101	0129	0010000001	0229	0011100101	0329	0101001001	0429	0110101101
0030	0000011110	0130	0010000010	0230	0011100110	0330	0101001010	0430	0110101110
0031	0000011111	0131	0010000011	0231	0011100111	0331	0101001011	0431	0110101111
0032	0000100000	0132	0010000100	0232	0011101000	0332	0101001100	0432	0110110000
0033	0000100001	0133	0010000101	0233	0011101001	0333	0101001101	0433	0110110001
0034	0000100010	0134	0010000110	0234	0011101010	0334	0101001110	0434	0110110010
0035	0000100011	0135	0010000111	0235	0011101011	0335	0101001111	0435	0110110011
0036	0000100100	0136	0010001000	0236	0011101100	0336	0101010000	0436	0110110100
0037	0000100101	0137	0010001001	0237	0011101101	0337	0101010001	0437	0110110101
0038	0000100110	0138	0010001010	0238	0011101110	0338	0101010010	0438	0110110110
0039	0000100111	0139	0010001011	0239	0011101111	0339	0101010011	0439	0110110111
0040	0000101000	0140	0010001100	0240	0011110000	0340	0101010100	0440	0110111000
0041	0000101001	0141	0010001101	0241	0011110001	0341	0101010101	0441	0110111001
0042	0000101010	0142	0010001110	0242	0011110010	0342	0101010110	0442	0110111010
0043	0000101011	0143	0010001111	0243	0011110011	0343	0101010111	0443	0110111011
0044	0000101100	0144	0010010000	0244	0011110100	0344	0101011000	0444	0110111100
0045	0000101101	0145	0010010001	0245	0011110101	0345	0101011001	0445	0110111101
0046	0000101110	0146	0010010010	0246	0011110110	0346	0101011010	0446	0110111110
0047	0000101111	0147	0010010011	0247	0011110111	0347	0101011011	0447	0110111111
0048	0000110000	0148	0010010100	0248	0011111000	0348	0101011100	0448	0111000000
0049	0000110001	0149	0010010101	0249	0011111001	0349	0101011101	0449	0111000001
0050	0000110010	0150	0010010110	0250	0011111010	0350	0101011110	0450	0111000010
0051	0000110011	0151	0010010111	0251	0011111011	0351	0101011111	0451	0111000011
0052	0000110100	0152	0010011000	0252	0011111100	0352	0101100000	0452	0111000100
0053	0000110101	0153	0010011001	0253	0011111101	0353	0101100001	0453	0111000101
0054	0000110110	0154	0010011010	0254	0011111110	0354	0101100010	0454	0111000110
0055	0000110111	0155	0010011011	0255	0011111111	0355	0101100011	0455	0111000111
0056	0000111000	0156	0010011100	0256	0100000000	0356	0101100100	0456	0111001000
0057	0000111001	0157	0010011101	0257	0100000001	0357	0101100101	0457	0111001001
0058	0000111010	0158	0010011110	0258	0100000010	0358	0101100110	0458	0111001010
0059	0000111011	0159	0010011111	0259	0100000011	0359	0101100111	0459	0111001011
0060	0000111100	0160	0010100000	0260	0100000100	0360	0101101000	0460	0111001100
0061	0000111101	0161	0010100001	0261	0100000101	0361	0101101001	0461	0111001101
0062	0000111110	0162	0010100010	0262	0100000110	0362	0101101010	0462	0111001110
0063	0000111111	0163	0010100011	0263	0100000111	0363	0101101011	0463	0111001111
0064	0001000000	0164	0010100100	0264	0100001000	0364	0101101100	0464	0111010000
0065	0001000001	0165	0010100101	0265	0100001001	0365	0101101101	0465	0111010001
0066	0001000010	0166	0010100110	0266	0100001010	0366	0101101110	0466	0111010010
0067	0001000011	0167	0010100111	0267	0100001011	0367	0101101111	0467	0111010011
0068	0001000100	0168	0010101000	0268	0100001100	0368	0101110000	0468	0111010100
0069	0001000101	0169	0010101001	0269	0100001101	0369	0101110001	0469	0111010101
0070	0001000110	0170	0010101010	0270	0100001110	0370	0101110010	0470	0111010110
0071	0001000111	0171	0010101011	0271	0100001111	0371	0101110011	0471	0111010111
0072	0001001000	0172	0010101100	0272	0100010000	0372	0101110100	0472	0111011000
0073	0001001001	0173	0010101101	0273	0100010001	0373	0101110101	0473	0111011001
0074	0001001010	0174	0010101110	0274	0100010010	0374	0101110110	0474	0111011010
0075	0001001011	0175	0010101111	0275	0100010011	0375	0101110111	0475	0111011011
0076	0001001100	0176	0010110000	0276	0100010100	0376	0101111000	0476	0111011100
0077	0001001101	0177	0010110001	0277	0100010101	0377	0101111001	0477	0111011101
0078	0001001110	0178	0010110010	0278	0100010110	0378	0101111010	0478	0111011110
0079	0001001111	0179	0010110011	0279	0100010111	0379	0101111011	0479	0111011111
0080	0001010000	0180	0010110100	0280	0100011000	0380	0101111100	0480	0111100000
0081	0001010001	0181	0010110101	0281	0100011001	0381	0101111101	0481	0111100001
0082	0001010010	0182	0010110110	0282	0100011010	0382	0101111110	0482	0111100010
0083	0001010011	0183	0010110111	0283	0100011011	0383	0101111111	0483	0111100011
0084	0001010100	0184	0010111000	0284	0100011100	0384	0110000000	0484	0111100100
0085	0001010101	0185	0010111001	0285	0100011101	0385	0110000001	0485	0111100101
0086	0001010110	0186	0010111010	0286	0100011110	0386	0110000010	0486	0111100110
0087	0001010111	0187	0010111011	0287	0100011111	0387	0110000011	0487	0111100111
0088	0001011000	0188	0010111100	0288	0100100000	0388	0110000100	0488	0111101000
0089	0001011001	0189	0010111101	0289	0100100001	0389	0110000101	0489	0111101001
0090	0001011010	0190	0010111110	0290	0100100010	0390	0110000110	0490	0111101010
0091	0001011011	0191	0010111111	0291	0100100011	0391	0110000111	0491	0111101011
0092	0001011100	0192	0011000000	0292	0100100100	0392	0110001000	0492	0111101100
0093	0001011101	0193	0011000001	0293	0100100101	0393	0110001001	0493	0111101101
0094	0001011110	0194	0011000010	0294	0100100110	0394	0110001010	0494	0111101110
0095	0001011111	0195	0011000011	0295	0100100111	0395	0110001011	0495	0111101111
0096	0001100000	0196	0011000100	0296	0100101000	0396	0110001100	0496	0111101000
0097	0001100001	0197	0011000101	0297	01001				

Controlling the AR-3000 from an External Device

Phrase No.	Port No. 10987654321	Phrase No.	Port No. 10987654321	Phrase No.	Port No. 10987654321	Phrase No.	Port No. 10987654321	Phrase No.	Port No. 10987654321
0501	0111110101	0601	1001011001	0701	1010111101	0801	1100100001	0901	1110000101
0502	0111110110	0602	1001011010	0702	1010111110	0802	1100100010	0902	1110000110
0503	0111110111	0603	1001011011	0703	1010111111	0803	1100100011	0903	1110000111
0504	0111111000	0604	1001011100	0704	1011000000	0804	1100100100	0904	1110000100
0505	0111111001	0605	1001011101	0705	1011000001	0805	1100100101	0905	1110000101
0506	0111111010	0606	1001011110	0706	1011000010	0806	1100100110	0906	1110000110
0507	0111111011	0607	1001011111	0707	1011000011	0807	1100100111	0907	1110000111
0508	0111111100	0608	1001100000	0708	1011000100	0808	1100101000	0908	1110001100
0509	0111111101	0609	1001100001	0709	1011000101	0809	1100101001	0909	1110001101
0510	0111111110	0610	1001100010	0710	1011000110	0810	1100101010	0910	1110001110
0511	0111111111	0611	1001100011	0711	1011000111	0811	1100101011	0911	1110001111
0512	1000000000	0612	1001100100	0712	1011001000	0812	1100101100	0912	1110010000
0513	1000000001	0613	1001100101	0713	1011001001	0813	1100101101	0913	1110010001
0514	1000000010	0614	1001100110	0714	1011001010	0814	1100101110	0914	1110010010
0515	1000000011	0615	1001100111	0715	1011001011	0815	1100101111	0915	1110010011
0516	1000000100	0616	1001101000	0716	1011001100	0816	1100110000	0916	1110010100
0517	1000000101	0617	1001101001	0717	1011001101	0817	1100110001	0917	1110010101
0518	1000000110	0618	1001101010	0718	1011001110	0818	1100110010	0918	1110010110
0519	1000000111	0619	1001101011	0719	1011001111	0819	1100110011	0919	1110010111
0520	1000001000	0620	1001101100	0720	1011010000	0820	1100110100	0920	1110011000
0521	1000001001	0621	1001101101	0721	1011010001	0821	1100110101	0921	1110011001
0522	1000001010	0622	1001101110	0722	1011010010	0822	1100110110	0922	1110011010
0523	1000001011	0623	1001101111	0723	1011010011	0823	1100110111	0923	1110011011
0524	1000001100	0624	1001110000	0724	1011010100	0824	1100111000	0924	1110011100
0525	1000001101	0625	1001110001	0725	1011010101	0825	1100111001	0925	1110011101
0526	1000001110	0626	1001110010	0726	1011010110	0826	1100111010	0926	1110011110
0527	1000001111	0627	1001110011	0727	1011010111	0827	1100111011	0927	1110011111
0528	1000010000	0628	1001110100	0728	1011011000	0828	1100111100	0928	1110100000
0529	1000010001	0629	1001110101	0729	1011011001	0829	1100111101	0929	1110100001
0530	1000010010	0630	1001110110	0730	1011011010	0830	1100111110	0930	1110100010
0531	1000010011	0631	1001110111	0731	1011011011	0831	1100111111	0931	1110100011
0532	1000010100	0632	1001111000	0732	1011011100	0832	1101000000	0932	1110100100
0533	1000010101	0633	1001111001	0733	1011011101	0833	1101000001	0933	1110100101
0534	1000010110	0634	1001111010	0734	1011011110	0834	1101000010	0934	1110100110
0535	1000010111	0635	1001111011	0735	1011011111	0835	1101000011	0935	1110100111
0536	1000011000	0636	1001111100	0736	1011100000	0836	1101000010	0936	1110101000
0537	1000011001	0637	1001111101	0737	1011100001	0837	1101000011	0937	1110101001
0538	1000011010	0638	1001111110	0738	1011100010	0838	1101000010	0938	1110101010
0539	1000011011	0639	1001111111	0739	1011100011	0839	1101000011	0939	1110101011
0540	1000011100	0640	1010000000	0740	1011100100	0840	1101001000	0940	1110101100
0541	1000011101	0641	1010000001	0741	1011100101	0841	1101001001	0941	1110101101
0542	1000011110	0642	1010000010	0742	1011100110	0842	1101001010	0942	1110101110
0543	1000011111	0643	1010000011	0743	1011100111	0843	1101001011	0943	1110101111
0544	1000100000	0644	1010000100	0744	1011101000	0844	1101001100	0944	1110110000
0545	1000100001	0645	1010000101	0745	1011101001	0845	1101001101	0945	1110110001
0546	1000100010	0646	1010000110	0746	1011101010	0846	1101001110	0946	1110110010
0547	1000100011	0647	1010000111	0747	1011101011	0847	1101001111	0947	1110110011
0548	1000100100	0648	1010000100	0748	1011101100	0848	1101010000	0948	1110110100
0549	1000100101	0649	1010000101	0749	1011101101	0849	1101010001	0949	1110110101
0550	1000100110	0650	1010000110	0750	1011101110	0850	1101010010	0950	1110110110
0551	1000100111	0651	1010000111	0751	1011101111	0851	1101010011	0951	1110110111
0552	1000101000	0652	1010000100	0752	1011110000	0852	1101010100	0952	1110111000
0553	1000101001	0653	1010000101	0753	1011110001	0853	1101010101	0953	1110111001
0554	1000101010	0654	1010000110	0754	1011110010	0854	1101010110	0954	1110111010
0555	1000101011	0655	1010000111	0755	1011110011	0855	1101010111	0955	1110111011
0556	1000101100	0656	1010010000	0756	1011110100	0856	1101011000	0956	1110111100
0557	1000101101	0657	1010010001	0757	1011110101	0857	1101011001	0957	1110111101
0558	1000101110	0658	1010010010	0758	1011110110	0858	1101011010	0958	1110111110
0559	1000101111	0659	1010010011	0759	1011110111	0859	1101011011	0959	1110111111
0560	1000110000	0660	1010010100	0760	1011111000	0860	1101011100	0960	1111000000
0561	1000110001	0661	1010010101	0761	1011111001	0861	1101011101	0961	1111000001
0562	1000110010	0662	1010010110	0762	1011111010	0862	1101011110	0962	1111000010
0563	1000110011	0663	1010010111	0763	1011111011	0863	1101011111	0963	1111000011
0564	1000110100	0664	1010011000	0764	1011111100	0864	1101100000	0964	1111000100
0565	1000110101	0665	1010011001	0765	1011111101	0865	1101100001	0965	1111000101
0566	1000110110	0666	1010011010	0766	1011111110	0866	1101100010	0966	1111000110
0567	1000110111	0667	1010011011	0767	1011111111	0867	1101100011	0967	1111000111
0568	1000111000	0668	1010011100	0768	1100000000	0868	1101100100	0968	1111001000
0569	1000111001	0669	1010011101	0769	1100000001	0869	1101100101	0969	1111001001
0570	1000111010	0670	1010011110	0770	1100000010	0870	1101100110	0970	1111001010
0571	1000111011	0671	1010011111	0771	1100000011	0871	1101100111	0971	1111001011
0572	1000111100	0672	1010100000	0772	1100000100	0872	1101101000	0972	1111001100
0573	1000111101	0673	1010100001	0773	1100000101	0873	1101101001	0973	1111001101
0574	1000111110	0674	1010100010	0774	1100000110	0874	1101101010	0974	1111001110
0575	1000111111	0675	1010100011	0775	1100000111	0875	1101101011	0975	1111001111
0576	1001000000	0676	1010100100	0776	1100000100	0876	1101101100	0976	1111010000
0577	1001000001	0677	1010100101	0777	1100000101	0877	1101101101	0977	1111010001
0578	1001000010	0678	1010100110	0778	1100000110	0878	1101101110	0978	1111010010
0579	1001000011	0679	1010100111	0779	1100000111	0879	1101101111	0979	1111010011
0580	1001000100	0680	1010101000	0780	1100001100	0880	1101110000	0980	1111010100
0581	1001000101	0681	1010101001	0781	1100001101	0881	1101110001	0981	1111010101
0582	1001000110	0682	1010101010	0782	1100001110	0882	1101110010	0982	1111010110
0583	1001000111	0683	1010101011	0783	1100001111	0883	1101110011	0983	1111010111
0584	1001001000	0684	1010101100	0784	1100010000	0884	1101110100	0984	1111011000
0585	1001001001	0685	1010101101	0785	1100010001	0885	1101110101	0985	1111011001
0586	1001001010	0686	1010101110	0786	1100010010	0886	1101110110	0986	1111011010
0587	1001001011	0687	1010101111	0787	1100010011	0887	1101110111	0987	1111011011
0588	1001001100	0688	1010110000	0788	1100010100	0888	1101111000	0988	1111011100
0589	1001001101	0689	1010110001	0789	1100010101	0889	1101111001	0989	1111011101
0590	1001001110	0690	1010110010	0790	1100010110	0890	1101111010	0990	1111011110
0591	1001001111	0691	1010110011	0791	1100010111	0891	1101111011	0991	1111011111
0592	1001010000	0692	1010110100	0792	1100011000	0892	1101111100	0992	1111100000
0593	1001010001	0693	1010110101	0793	1100011001	0893	1101111101	0993	1111100001
0594	1001010010	0694	1010110110	0794	1100011010	0894	1101111110	0994	1111100010
0595	1001010011	0695	1010110111	0795	1100011011	0895	1101111111	0995	1111100011
0596	1001010100	0696	1010111000	0796	1100011100	0896	1110000000	0996	1111100100
0597	1001010101	0697	1010111001	0797	1100011101	0897	1110000001	0997	1111

Controlling Recording with the Control Terminals (Binary Recording)

What is Binary Recording/Uses and Applications

You can specify phrases by inputting binary (base 2) signals to Port Nos. 1 through 11, and perform record, playback, and erase functions by inputting control signals to Port Nos. 13 and 14. All phrases can be specified with control signals (ON/OFF). This is convenient when you want to control recording from an external control device.

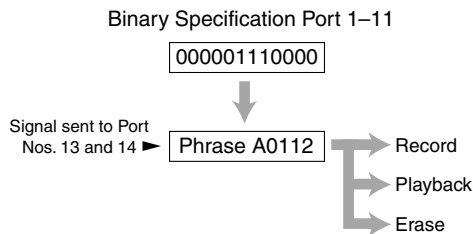

- * To conduct binary playback, you will need to obtain a control device capable of generating binary signals.
- * Input of binary specifications should be completed in no more than 50 milliseconds.

Connecting Equipment

Ports Used in Binary Recording

"1-10": Phrases are specified in binary format using combinations of 0 (OFF) and 1 (ON).

"11": 0 (OFF) and 1 (ON) are used to select Card A and Card B.

"13, 14": Record, erase, and playback are specified using combinations of 0 (OFF) and 1 (ON).

Set to "ON" by shorting the above-mentioned port and "COM (common)."

"CONT OUT": Outputs signals for confirming the presence or absence of phrases.

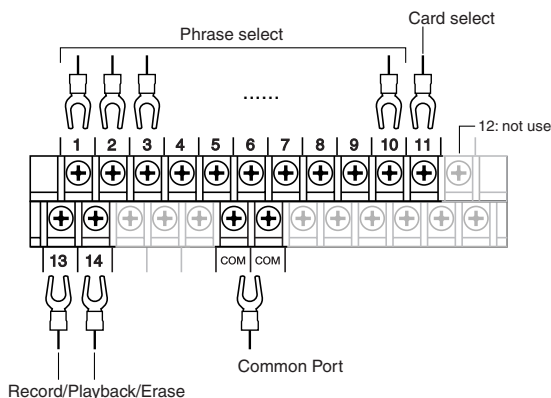

Turning the Power On and Off → p. 24

Operational Specifications for Binary Recording

Phrases are specified by combinations of signals of 0 (OFF) and 1 (ON) to the Port Nos. 1 through 10 as well as Port No. 11, and record, playback, and erase functions are specified with combinations of control signals of 0 (OFF) and 1 (ON) to Port Nos. 13 and 14.

Presence or Absence of Phrases

If there is a binary-specified phrase that has already been recorded, a signal is output from the CONT OUT port. If there is no phrase, no signal is output.

- * During Binary Recording, the CONT OUT port functions as a port for signals confirming the presence or absence of phrases. Note that this differs from the normal function of CONT OUT.

Timing Chart (The presence or absence of phrases)

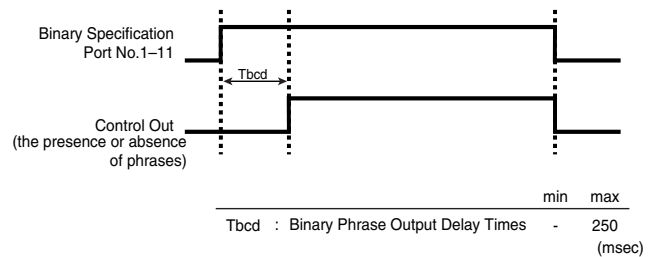

Controlling the AR-3000R from an External Device

Recording

13: 0 (OFF)

14: 1 (ON)

→ While control signals are being input, the specified phrase is recorded. When input of the control signal stops, recording then ends.

Timing Chart (Rec)

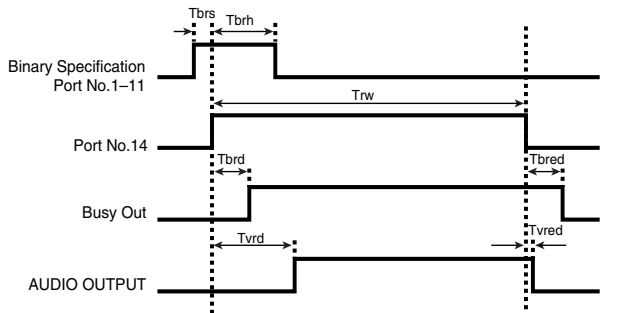

		min	max
Trw	: Play Pulse Width	300	-
Tbrs	: Binary Setup Time	200	-
Tbrh	: Binary Hold Time	100	-
Tbrd	: Busy Delay Time	-	300
Tvrd	: Audio Delay Time	-	300
Tbred	: End Busy Delay Time	-	100
Tvred	: End Audio Delay Time	-	100

(msec)

* Recording does not start if there is a binary-specified phrase that has already been recorded (the recording instruction is disabled). When recording, either specify an empty phrase or delete the existing phrase before recording the new one. Additionally, in Binary Recording, since a make signal is output from the CONT OUT port when a specified phrase has already been recorded, this allows confirmation using a connected external control device.

Playback

13: 1 (ON)

14: 0 (OFF)

→ The specified phrase is played back. Even when control signals are input continuously, the phrase is played back one time only and then ends.

Timing Chart (PLAY)

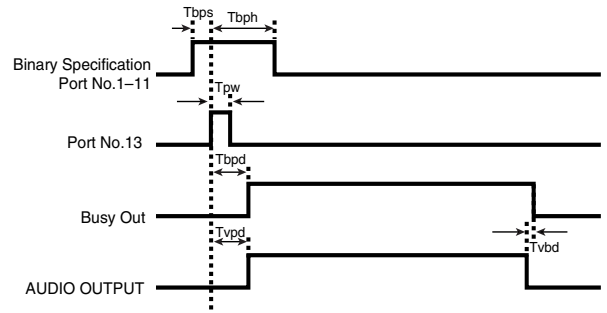

		min	max
Tpw	: Play Pulse Width	20	-
Tbps	: Binary Setup Time	200	-
Tbph	: Binary Hold Time	100	-
Tbpd	: Busy Delay Time	-	300
Tvpg	: Audio Delay Time	-	300
Tvbd	: End Busy Delay Time	-	100

(msec)

* Playback does not begin if the binary-specified phrase is empty (the playback instruction is disabled). When playing back, specify a phrase that has already been recorded.

Controlling the AR-3000R from an External Device

Erase

14: 1 (ON)

13: 1 (ON)

→ First, when ON is input to Port No. 14, and then ON is input to Port No. 13, erasure of the specified phrase begins. Erasure ends when the signal from the CONT OUT port (confirming the presence or absence of the phrase) changes to OFF.

- * Erasure does not begin if the binary-specified phrase is empty (the playback instruction is disabled). When erasing, specify a phrase that has already been recorded.

Timing Chart (Delete)

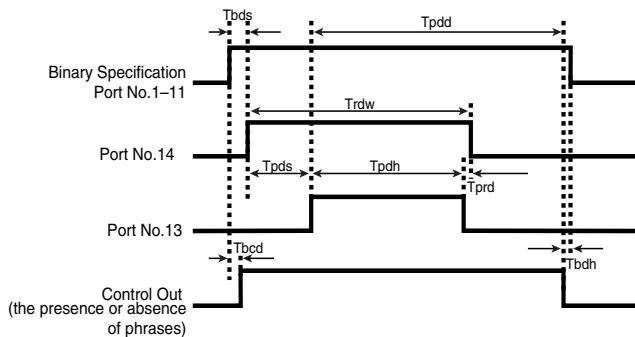

	min	max
Trdw : Delete Rec Pulse Width	100	-
Tpds : Delete Play Setup Time	50	-
Tpdh : Delete Play Hold Time	50	-
Tprd : Delete Play Rec Delay Time	0	-
Tbds : Delete Binary Setup Time	200	-
Tbdh : Delete Binary Hold Time	20	-
Tbcd : Binary Phrase Output Delay Time	-	250
Tpdd : Play Phrase Output Delay Time	-	2500 (typ.)

(msec)

- * Tpdd: Play phrase output delay time is dependent on the card used.

AR-3000R Settings

NOTE

If a card in AR-2000 format is inserted in either slot A or B (or both), the AR-3000R can be used only for playback, and it is not possible to record phrases or make any settings (except for card conversion). Also, if you insert a card in AR-2000 format into slot A or B (or both) while making settings (except for card conversion), operation will halt with an error message, and cannot be resumed until such cards are removed. To record or edit cards in AR-2000 format on the AR-3000R, follow the steps in "Card Convert" (p. 78).

Selecting the Control Input Mode

Select "BINARY REC" from the control input modes (DIRECT PLAY/PROGRAM PLAY/BINARY PLAY/BINARY REC).

- * You cannot achieve Binary Recording merely by connecting a device to the port. Be sure to set the control input mode to match the method used for connecting to the ports.

Procedure for Setting the Control Input Mode

1. Press the MODE button.

The MODE indicator lights up.

2. Use the SELECT dial to choose "5.1 Control Input Mode," then press the dial.
3. Turn the SELECT dial to choose "BINARY REC," then press the dial.

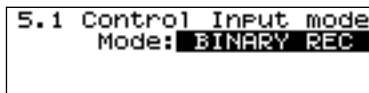

4. When the prompt appears on the screen, press the ENTER button to enable the settings.

To quit without making the settings, use the SELECT dial to choose "NO," then press the ENTER button.

Once the settings have been made successfully, you're returned to the setting item selection screen.

5. Press the MODE button.

This ends the setting process and returns you to the usual screen.

- * If you press the MODE button while making settings, a message asking you to confirm that you want to exit the setting process appears. Note that if you choose "YES," then press the ENTER button, you are returned to the usual screen, and all setting changes you've made up to that point will be discarded.

Selecting the Phrase Specification (BINARY 1/BINARY 2)

Select the method (BINARY 1 or BINARY 2) used for specifying the phrase.

BINARY 1: Binary specification normally used.



Phrase Number/Binary Signal Correspondence Table → p. 96

BINARY 2: Method by which phrases are specified in sequence from Phrase 0001: Binary 0000000000.



About Binary Specification When BINARY 2 is Selected → p. 101

Procedure for Setting the Phrase Specification

1. Press the MODE button.
The MODE indicator lights up.
2. Use the SELECT dial to choose "5.5 Binary Recording," then press the dial.
3. Turn the SELECT dial to choose the Phrase Select (BINARY 1 or BINARY 2), then press the dial.

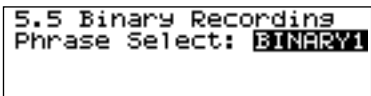

4. When the prompt appears on the screen, press the ENTER button to enable the settings.

To quit without making the settings, use the SELECT dial to choose "NO," then press the ENTER button.

Once the settings have been made successfully, you're returned to the setting item selection screen.

5. Press the MODE button.

This ends the setting process and returns you to the usual screen.

** If you press the MODE button while making settings, a message asking you to confirm that you want to exit the setting process appears. Note that if you choose "YES," then press the ENTER button, you are returned to the usual screen, and all setting changes you've made up to that point will be discarded.*

To Specify Phrases With Binary Signals

Example: Specifying Phrase A0015 (Card: A, Phrase #: 0015)

(* Phrase Specification: When BINARY 1 is Selected)

1. Convert the phrase number to a binary signal number.
"0" (OFF)
"1" (ON)



Phrase Number/Binary Signal Correspondence Table (p. 96)

The phrase number "0015" becomes the binary signal "0000001111."

2. Select Card A or B with and ON or OFF control signal to Port No. 11.

Card A: "0" (OFF)

Card B: "1" (ON)

** If there is no connection to Port No. 11, this is the same as "OFF," and Card A is selected.*

With the above steps, Phrase No. A0015 is converted to:

Port No.	→	1	2	3	4	5	6	7	8	9	10
Input signal	→	1	1	1	1	0	0	0	0	0	0
		Phrase No. (Binary)									Card



- Note that the direction of the phrase numbers (binary) and port numbers are reversed.
- Input of binary specifications should be completed in no more than 50 milliseconds.



Phrase Number/Binary Signal Correspondence Table → p. 96

About Binary Specification When BINARY 2 is Selected

When phrases are selected with "BINARY 2," Phrase 0001 changes to "0000000000" in the binary specification, with each subsequent specification shifted by one.

0001	→	0000000000
0001	→	0000000001
0002	→	0000000010
0003	→	0000000011
0004	→	0000000100
0005	→	0000000101
0006	→	0000000110
0007	→	0000000111
.		.
.		.
.		.
.		.
.		.
0998	→	1111100110
0999	→	1111100111
1000	→	1111100111

Substituting the appropriate entries in "Phrase Number/Binary Signal Correspondence Table" (p. 96) according to the above figure.

Applications

Controlling Another Device with the AR-3000R (Control Output Terminal)

You can control an external device from the AR-3000R by using the output connectors among the screw-on control terminals on the unit's rear panel.

The AR-3000R outputs two types of control signals: BUSY OUT and CONTROL OUT.

This chapter describes how to connect external equipment and make the settings on the AR-3000R.

MEMO

To confirm phrases when making settings, you can use the PLAY/STOP button to play and stop phrases and the PAUSE button to pause phrases (audio phrases only), and the SELECT dial to move the playback location forward and backward (audio phrases only). Note that you cannot change settings during phrase playback.



Also refer to "Examples of Usage and Connection for the AR-3000R" (p. 19) for more examples of usage of the control input and output terminals.



For information about the specifications of the control input and output terminals, refer to "Specifications of the Control Input/Output Terminals" (p. 137).

Important Notes on Using the Control Input and Output Terminals

- * The control input and output terminals cannot be used to switch the power to the AR-3000R on or off.

NOTE

When making connections to the ports, be careful not to lose the removed screws. Place the screws out of the reach of small children. If a screw is accidentally swallowed, immediately consult a physician.

Starting Another Device (Busy Out)

What Is a Busy Out Signal?/ Equipment Connections

A Busy Out signal is a signal that is continuously output from the BUSY OUT port during playback (and during recording and recording standby) of audio phrases, MIDI phrases, pattern phrases, and song phrases.

You can use this signal to start an amp or other external device in sync with phrase playback.

The setting for whether or not the Busy Out signal is to be output is made separately respective to the following three situations:

- During the delay time set in a phrase (p. 55): in Delay Time ON/OFF
- During phrase playback: in Phrase Play ON/OFF
- During the repeat interval set in a phrase (p. 57): in Repeat Int ON/OFF

The setting is made on a system-wide basis (that is, it cannot be made separately for individual phrases).

The Busy Out specifications are no-voltage/make-contact, with a contact capacity of a maximum of DC 30 V at 5 A.

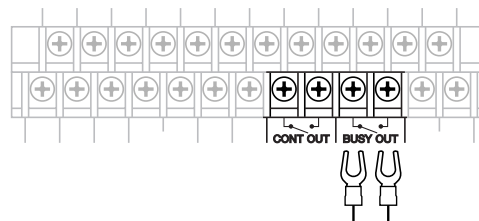

Turning the Power On and Off → p. 24

Busy Out Signal Output During Playback of Pattern Phrases and Song Phrases

Both pattern phrases and song phrases (p. 62, p. 65) are each handled as single phrases, so during playback the Busy Out signal is output without interruption.

Busy Out Signal Output During Dual Mono Mode Playback

During Dual Mono mode playback, the left-channel Busy Out signal is output from the BUSY OUT port, and the right-channel Busy Out signal is output from the CONT OUT port.



Dual Mono Mode → p. 120

AR-3000R Settings

The setting for the Busy Out signal is a system-wide setting (that is, it is not made separately for individual phrases).

The setting for whether the Busy Out signal is output is made separately in the following three situations. Choose the one that matches your usage conditions.

- In the delay time set in a phrase (p. 55): in Delay Time ON/OFF
- During phrase playback: in Phrase Play ON/OFF
- During the repeat interval set in a phrase (p. 57): in Repeat Int ON/OFF

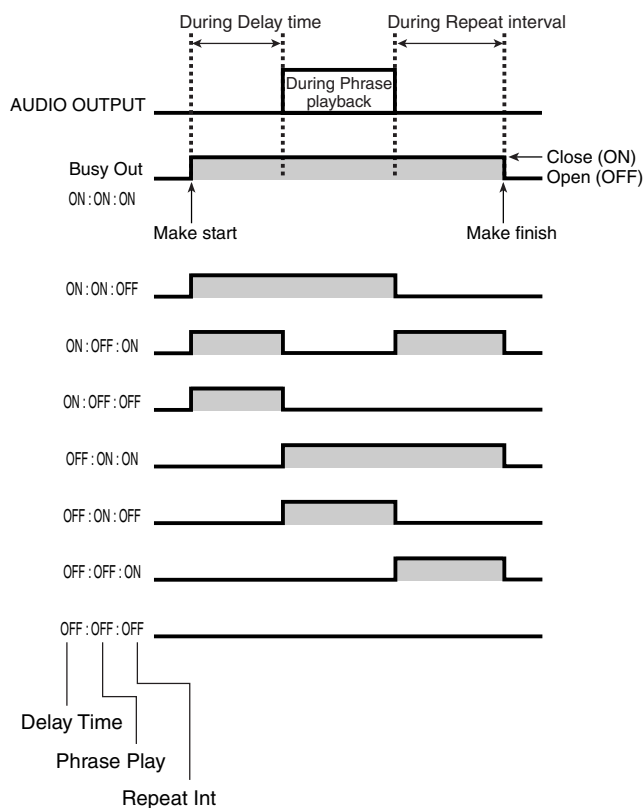

Inserting into a phrase a delay time equal to the start time for the amp (the time until sound is played) can help prevent drop-out at the beginning of the phrase during playback.

Procedure for Making the Setting for Busy Out Signal Output

1. Press the MODE button.
The MODE indicator lights up.
2. Use the SELECT dial to choose "9.5 Busy Out," then press the dial.

3. Turn the SELECT dial to choose "in Delay Time (OFF or ON)," then press the dial.

```

9.5 Busy Out
During Delay Time: ON
During Phrase Play: ON
During Repeat Int: ON
    
```

4. Turn the SELECT dial to choose "in Phrase Play (OFF or ON)," then press the dial.
5. Turn the SELECT dial to choose "in Repeat Interval (OFF or ON)," then press the dial.
6. When the prompt appears on the screen, press the ENTER button to enable the settings.

To quit, use the SELECT dial to choose "NO," then press the ENTER button.

When you're finished making the setting, the display returns to the setting item selection screen.

7. Press the MODE button.

This ends the setting process and returns you to the usual screen.

- * While making the settings, you can go back to the previous entry position (highlighted) by using the PAUSE (BACK) button.
- * If you press the MODE button while making settings, a message asking you to confirm that you want to exit the setting process appears. Note that if you choose "YES," then press the ENTER button, you are returned to the usual screen, and all setting changes you've made up to that point will be discarded.

Controlling Another Device (Control Out)

What Is a Control Out Signal?/ Equipment Connections

The Control Out signal is a signal that is output from the CONT OUT port for one second after playback of audio phrases, MIDI phrases, pattern phrases, and song phrases.

You can use it to control external equipment, using the timing at which phrase playback ends.

You can set the time that is to pass after phrase playback before output is made to anything from 0 seconds to 59 minutes 59 seconds. The setting is made separately for individual phrases.

The Control Out specifications are no-voltage/make-contact, with a make-contact time of 1 second and a contact capacity of a maximum of DC 30 V at 5 A.

NOTE

Please be aware that if you cancel phrase playback partway through, no Control Out signal is output.

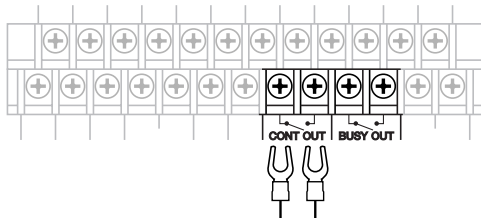

Turning the Power On and Off → p. 24

Control Out Signal Output During Playback of Pattern Phrases and Song Phrases

Both pattern phrases and song phrases (p. 62, p. 65) are each handled as single phrases, so the Control Out signal is output after phrase playback ends.

Control Out Signal Output During Dual Mono Mode Playback

Note that no Control Out signal is output during Dual Mono mode playback (because the Control Out setting (p. 59) is not valid).

At this time, if the Busy Out setting has been made, the left-channel Busy Out signal is output from the BUSY OUT port, and the right-channel Busy Out signal is output from the CONT OUT port.

AR-3000R Settings

The setting for the Control Out signal is made separately for individual phrases.

When you make the Control Out setting, in addition to making the setting for whether the signal is output, you can also set the time until output after phrase playback (the offset time) to anything from 0 seconds to 59 minutes 59 seconds.

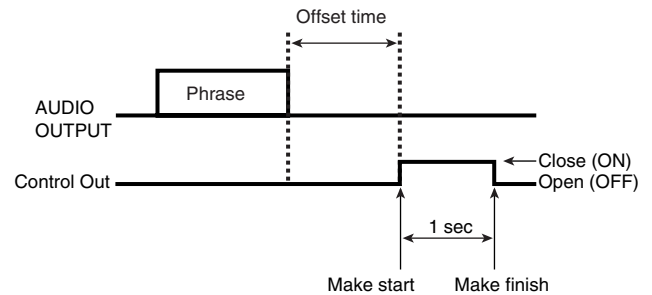

The setting for Control Out is made with Phrase Settings. Refer to "Control Out" (p. 59).

NOTE

During the offset time, when phrase playback ends due to the next playback instruction, operation will proceed according to the setting information for the phrase played back afterwards. Note that the settings for the first phrase are deactivated.

Controlling the AR-3000R Using MIDI Signals (MIDI Control)

What Is MIDI Control?/What You Can Do with MIDI Control

MIDI stands for “Musical Instrument Digital Interface,” and is a unified worldwide standard allowing the exchange of performance information and the like between electronic instruments and computers. You can connect any device conforming to the MIDI standard with a MIDI cable, and then transmit performance data and control the device’s operation and settings.

With the AR-3000R, you can do things like those described below using MIDI signals.

- You can record and play back MIDI signals from an external MIDI device in the same manner as with audio phrases.



For more about recording and playing back MIDI signals, refer to “Recording and Playing MIDI Data” (p. 82).

- You can use MIDI signals from an external MIDI device as control signals for controlling playback of audio and MIDI phrases.
- You can use MMC and MTC signals from an external MIDI device for remote control and synchronized operation.

- You can use received MMC signals to start and stop recording and playback of audio phrases (p. 110).



What Is MMC?/Remote Control from Another Device → p. 110

- By using MMC and MTC signals in combination, you can synchronize playback of audio phrases to video equipment or the like.



What Is MTC?/Synchronized Playback with Video Equipment and the Like → p. 112

Also see the “MIDI Implementation Chart” (p. 144), which allows easy confirmation of the MIDI messages that the unit can send and receive, and “MIDI Implementation” (p. 139), which gives detailed MIDI specifications.

Glossary of Selected MIDI Terms

MIDI messages: These are messages conveyed by MIDI signals. These messages are necessary for playing performances on an external MIDI sound generating device. They include note messages for playing and stopping notes, as well as Control Change and System Exclusive (SysEx) messages, which can modify and enhance the expressive capabilities of performances.

Note number: This is a number assigned to each key (note) on the keyboard of an electronic musical instrument.

Numbers are assigned in semitone steps, with middle C (C4) set at 60 and the numbers from 0 to 127 indicating the positions of the keys on the keyboard. On the AR-3000R these are used to specify phrases.

Note On: This is a message that provides information on when the keyboard of a MIDI instrument is fingered.

Note On Velocity: This is a message that provides information on the force (velocity) used when pressing a key.

Note Off: This is a message that provides information on when the keys of a MIDI instrument are released.

Program Change: This is a message that provides information for switching sounds on an electronic instrument. On the AR-3000R, this is used to switch phrase sets in groups of 100.

Control Change: MIDI instrument performances use a variety of controllers, not just for the keyboard. The MIDI message that conveys such controller action is the Control Change. The AR-3000R receives and acts upon Panpot and Expression messages.

Playback of Phrases Using MIDI Signals

This plays back audio and MIDI phrases using MIDI signals from an external MIDI device as control signals.

Phrase playback can be controlled by the different types of MIDI messages, including Note On/Off, Note On Velocity, Panpot, and Expression.

- * Note that simultaneous recording and simultaneous playback of audio phrases and MIDI phrases is not possible.
- * Phrases for which RDAC-Mode is set to MODE2 cannot be synchronized with MTC.



In addition to these, you can use Exclusive (SysEx) messages to control starting and stopping for recording and playback, make settings for recording, and specify phrases. For more information, refer to MIDI Implementation (p. 139).

Connecting External Equipment

When Playing Back Audio Phrases Using MIDI Signals

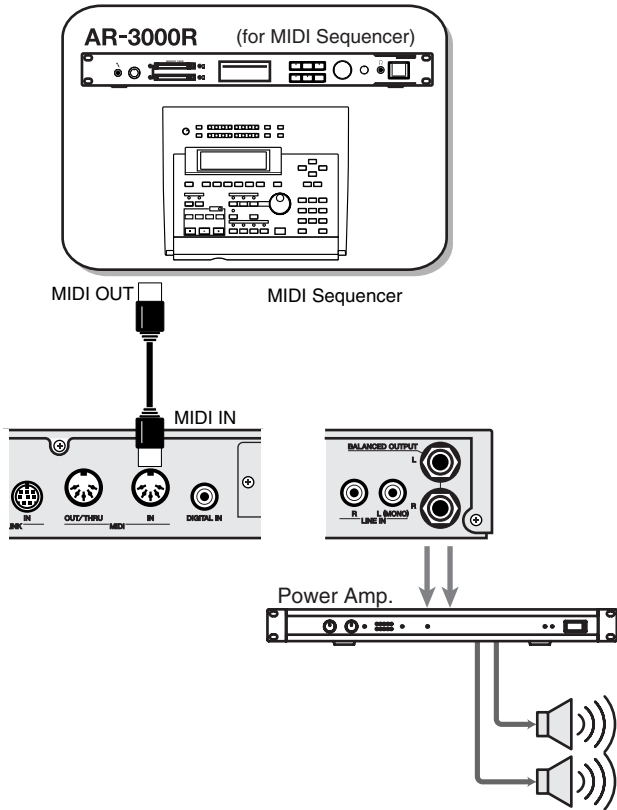

When Playing Back MIDI Phrases Using MIDI Signals

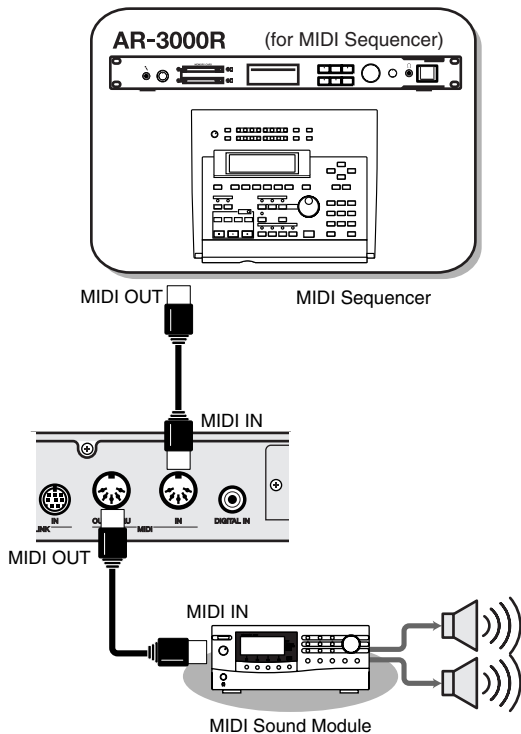

Turning the Power On and Off → p. 24

AR-3000R Settings

Selection of MIDI Output (MIDI OUT or MIDI THRU)

This changes the function of the MIDI output port.

OUT: This sends MIDI information from the unit. Select this when you want to play back MIDI phrases or send Exclusive (SysEx) messages.

THRU: This takes MIDI information from MIDI IN and sends it out unchanged. MIDI signals from the unit are not output.

Procedure for Setting MIDI Output (MIDI OUT or MIDI THRU)

1. Press the MODE button.
The MODE indicator lights up.
2. Use the SELECT dial to choose "6.1 MIDI Output," then press the dial.
3. Turn the SELECT dial to choose the MIDI output (OUT or THRU), then press the dial.

```
6.1 MIDI Output
MIDI Output: OUT
```

4. When the prompt appears on the screen, press the ENTER button to enable the settings.

To quit without making the settings, use the SELECT dial to choose "NO," then press the ENTER button.

Once the settings have been successfully modified, you're returned to the setting item selection screen.

5. Press the MODE button.

This ends the setting process and returns you to the usual screen.

* If you press the MODE button while making settings, a message asking you to confirm that you want to exit the setting process appears. Note that if you choose "YES," then press the ENTER button, you are returned to the usual screen, and all setting changes you've made up to that point will be discarded.

Note Number Phrase Assignments (MIDI Note Map)

A Note On message causes the phrase with the corresponding note number to be played back. You can choose all phrases by changing the phrases sets in groups of 100 using Program Change messages.

You can freely assign phrases to the Program Change 1 note numbers (128 numbers).

NOTE

Although you can select phrases from Card A as well as Card B, note that playback will not work properly if the card inserted when the phrase was registered is not inserted at playback. (If the phrase is not saved, the playback signal is ignored).

Settings When Formatting Cards (in Slot A)

Program Change 1

Note Number	Phrase
C-1	A0001
C#-1	A0002
D-1	A0003
:	:
G9	A0128

MIDI Note Map (Phrase Assignments from Program Changes and Note Numbers)

Program Change	Note No.	Phrase No.
1	C-1 – G9	You can assign 128 phrases however you like.
21	C-1 – D#7	A0001 – A0100
22	C-1 – D#7	A0101 – A0200
23	C-1 – D#7	A0201 – A0300
24	C-1 – D#7	A0301 – A0400
25	C-1 – D#7	A0401 – A0500
26	C-1 – D#7	A0501 – A0600
27	C-1 – D#7	A0601 – A0700
28	C-1 – D#7	A0701 – A0800
29	C-1 – D#7	A0801 – A0900
30	C-1 – D#7	A0901 – A1000
71	C-1 – D#7	B0001 – B0100
72	C-1 – D#7	B0101 – B0200
73	C-1 – D#7	B0201 – B0300
74	C-1 – D#7	B0301 – B0400
75	C-1 – D#7	B0401 – B0500
76	C-1 – D#7	B0501 – B0600
77	C-1 – D#7	B0601 – B0700
78	C-1 – D#7	B0701 – B0800
79	C-1 – D#7	B0801 – B0900
80	C-1 – D#7	B0901 – B1000
2	C-1 – D#7	A0001 – A0100
3	C-1 – D#7	A0101 – A0200
4	C-1 – D#7	A0201 – A0300
5	C-1 – D#7	A0301 – A0400
6	C-1 – D#7	A0401 – A0500
7	C-1 – D#7	B0001 – B0100
8	C-1 – D#7	B0101 – B0200
9	C-1 – D#7	B0201 – B0300
10	C-1 – D#7	B0301 – B0400
11	C-1 – D#7	B0401 – B0500
128	C-1 – G9	The phrase being played back is stopped.

<Program Change 1>

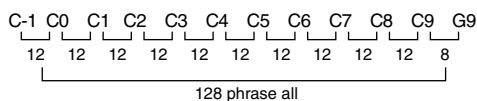

<Program Change 21–30, 71–80, 2–11>

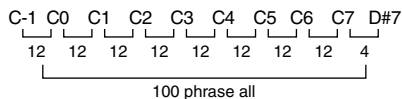

- * The 1,000 phrases on card A are assigned to Program Changes 21 through 30, and the phrase assignments cannot be changed.
- * The 1,000 phrases on card B are assigned to Program Changes 71 through 80, and the phrase assignments cannot be changed.
- * For compatibility with the AR-2000 format, 500 phrases on card A and 500 phrases on card B are assigned to Program Changes 2 through 6, and 7 through 11, and the phrase assignments cannot be changed.
- * With Program Change 128, playback of the phrase in progress is stopped by switching any note number on.

Procedure for Making the MIDI Note Map Settings

1. Press the MODE button.

The MODE indicator lights up.

2. Use the SELECT dial to choose "6.2 MIDI Note Map," then press the dial.
3. Turn the SELECT dial to choose the note number you want to set, then press the dial.

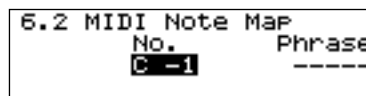

- **C-1 through G9:** Note number
 - **End:** To finish making settings.
 - **Reset:** This restores the settings at the time the card was formatted.
 - **Clear:** This erases all settings.
4. Turn the SELECT dial to choose the card containing the phrase you want to store, then press the dial.

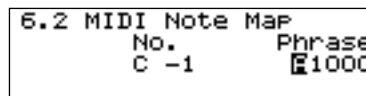

5. Turn the SELECT dial to choose the phrase you want to store, then press the dial.
6. Repeat steps 3 and 4 to assign phrases.
7. To cancel the save process, then in step 3, turn the SELECT dial to choose END, then press the dial.

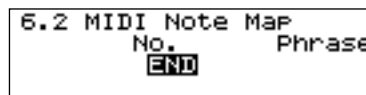

8. When the prompt appears on the screen, press the ENTER button to enable the settings.

To quit without making the settings, use the SELECT dial to choose "NO," then press the ENTER button. Once the settings have been successfully modified, you're returned to the setting item selection screen.

Controlling the AR-3000R Using MIDI Signals (MIDI Control)

9. Press the MODE button.

This ends the setting process and returns you to the usual screen.

- * While making the settings, you can go back to the previous entry position (highlighted) by using the PAUSE (BACK) button.
- * If you press the MODE button while making settings, a message asking you to confirm that you want to exit the setting process appears. Note that if you choose "YES," then press the ENTER button, you are returned to the usual screen, and all setting changes you've made up to that point will be discarded.

MIDI Receive Channel (MIDI Channel) Setting

This sets the MIDI receive channel. With MIDI, you can send different information to a number of MIDI instruments on a single MIDI cable. For example, when the MIDI channel for the sending device is set to "1," then unless the MIDI channel of the receiving device (here, the AR-3000R) is also set to "1," the MIDI message is not transmitted.

OFF: There is no phrase playback using MIDI signals.

1 through 16: MIDI signals are received and played back only on the selected channel.

ALL: Phrases are played back regardless of the MIDI channel.

Procedure for Making the MIDI Receive Channel Settings

1. Press the MODE button.
The MODE indicator lights up.
2. Use the SELECT dial to choose "6.4 MIDI Channel," then press the dial.
3. Turn the SELECT dial to choose the MIDI Channel (OFF, 1 through 16, or ALL), then press the dial.

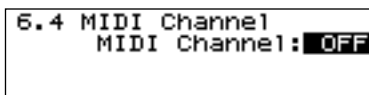

```
6.4 MIDI Channel
MIDI Channel: OFF
```

4. When the prompt appears on the screen, press the ENTER button to enable the settings.

To quit without making the settings, use the SELECT dial to choose "NO," then press the ENTER button.

Once the settings have been successfully modified, you're returned to the setting item selection screen.

5. Press the MODE button.

This ends the setting process and returns you to the usual screen.

- * If you press the MODE button while making settings, a message asking you to confirm that you want to exit the setting process appears. Note that if you choose "YES," then press the ENTER button, you are returned to the usual screen, and all setting changes you've made up to that point will be discarded.

Handling of Note Off Signals (Note Trigger)

This sets how Note Off signals are handled during phrase playback through MIDI.

Trigger: Note Off signals are ignored.

Gate: Phrase playback stops when an off signal is received.

With Program Change 128, playback of the phrase in progress is stopped by switching any note number on.

Procedure for Making the Note Trigger Setting

1. Press the MODE button.
The MODE indicator lights up.
2. Use the SELECT dial to choose "6.5 MIDI Note Trigger," then press the dial.
3. Turn the SELECT dial to choose the Note Trigger (TRIGGER or GATE), then press the dial.

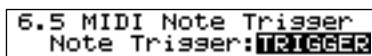

```
6.5 MIDI Note Trigger
Note Trisser: TRIGGER
```

4. When the prompt appears on the screen, press the ENTER button to enable the settings.

To quit without making the settings, use the SELECT dial to choose "NO," then press the ENTER button.

Once the settings have been successfully modified, you're returned to the setting item selection screen.

5. Press the MODE button.

This ends the setting process and returns you to the usual screen.

- * If you press the MODE button while making settings, a message asking you to confirm that you want to exit the setting process appears. Note that if you choose "YES," then press the ENTER button, you are returned to the usual screen, and all setting changes you've made up to that point will be discarded.

MIDI Control Signals That the AR-3000R Can Receive (Receive Messages)

The AR-3000R can receive the MIDI messages described below.

Note On Velocity: Volume level when a phrase starts

Panpot (CC10): Change in stereo position on the left and right channels

Expression (CC11): Change in master volume



MIDI Implementation and MIDI Implementation Chart → p. 139 through p. 145

Procedure for Making the Receive Message Setting

1. Press the MODE button.
The MODE indicator lights up.
2. Use the SELECT dial to choose “6.6 MIDI RX Message,” then press the dial.
3. Turn the SELECT dial to choose the Note On Velocity (OFF or ON), then press the dial.

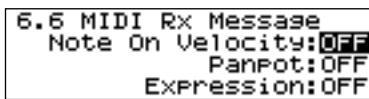

4. Turn the SELECT dial to choose the Panpot (OFF or ON), then press the dial.
5. Turn the SELECT dial to choose the Expression (OFF or ON), then press the dial.
6. When the prompt appears on the screen, press the ENTER button to enable the settings.

To quit without making the setting, use the SELECT dial to choose “NO,” then press the ENTER button.

Once the settings have been successfully modified, you’re returned to the setting item selection screen.

7. Press the MODE button.

This ends the setting process and returns you to the usual screen.

- * While making the settings, you can go back to the previous entry position (highlighted) by using the PAUSE (BACK) button.
- * If you press the MODE button while making settings, a message asking you to confirm that you want to exit the setting process appears. Note that if you choose “YES,” then press the ENTER button, you are returned to the usual screen, and all setting changes you’ve made up to that point will be discarded.

Operation Procedures

When you have finished making the settings, send MIDI signals from the external MIDI instrument. When messages are received, the unit starts playing back the phrases.

MIDI Note Out

If MIDI Note Out is set to “ON,” then when an audio phrase is played back, the MIDI Note Number On/Off signals set in the MIDI Note Map (p. 107) are output from the MIDI OUT connector.

It’s possible to use this signal to control a number of AR-3000R units.

- * If multiple note numbers are selected for the playback phrase, only the on or off signal for the lowest note number is output.



Output is on the MIDI channel set with the MIDI receive channel (p. 108).

If the MIDI receive channel is set to:

- **OFF:** There is no output.
- **1 through 16:** Only the MIDI signals received on the selected channel are output.
- **ALL:** Output is on channel 1.

- * When you are controlling a number of AR-3000R units using note Numbers, set the MIDI note trigger (p. 108) for the controlled AR-3000R to Trigger.

- * Even when MIDI phrases are played back, note number on/off signals are not output.

Procedure for Making the MIDI Note Out Channel Settings

1. Press the MODE button.
The MODE indicator lights up.
2. Use the SELECT dial to choose “6.3 MIDI Note Out,” then press the dial.
3. Turn the SELECT dial to choose the MIDI Note Output (ON or OFF), then press the dial.

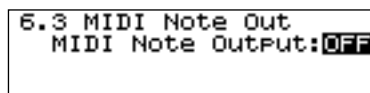

4. When the prompt appears on the screen, press the ENTER button to enable the settings.

To quit without making the settings, use the SELECT dial to choose “NO,” then press the ENTER button.

Once the settings have been successfully modified, you’re returned to the setting item selection screen.

5. Press the MODE button.

This ends the setting process and returns you to the usual screen.

- * If you press the MODE button while making settings, a message asking you to confirm that you want to exit the setting process appears. Note that if you choose “YES,” then press the ENTER button, you are returned to the usual screen, and all setting changes you’ve made up to that point will be discarded.

Synchronizing Operation to an External MIDI Instrument – 1 (MMC)

What Is MMC?/Remote Control from Another Device

What is MMC (MIDI Machine Control)?

MMC refers to MIDI messages that were devised in accord with certain agreements as to how to facilitate the centralized control of a multiple number of recording devices using one device. In addition to playback, stopping, and fast forwarding of songs, you can also select tracks for recording and carry out other operations merely by operating the one device which functions as the master. Use of MMC signals requires that the other devices be capable of remote operation using MMC signals.

The AR-3000R can work as a remote-control device, starting and stopping recording and playback of audio phrases when MMC signals are received from a hard-disk recorder or the like.



MIDI Implementation and MIDI Implementation Chart → p. 139 through p. 145

Connecting External Equipment

You can use the AR-3000R either as an MMC master or an MMC slave.

In this connection example, the unit is used as a slave.

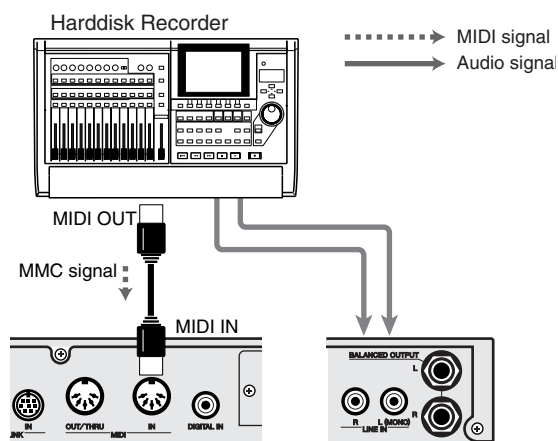

In situations such as when you carry out recording and editing with a hard-disk recorder and record the finished results on the AR-3000R, you can control AR-3000R from the hard-disk recorder.



Turning the Power On and Off → p. 24

AR-3000R Settings

Selection of MIDI Output (MIDI OUT or MIDI THRU)

This switches the functioning of the MIDI output connector.

OUT: MIDI information from the AR-3000R is sent. Select this when you want to play back MIDI phrases or send Exclusive (SysEx) messages.

THRU: This takes MIDI information from MIDI IN and sends it out unchanged. MIDI information from the AR-3000R itself is not output.

Procedure for Setting MIDI Output

1. Press the MODE button.

The MODE indicator lights up.

2. Use the SELECT dial to choose "6.1 MIDI Output," then press the dial.
3. Turn the SELECT dial to choose the MIDI Output (OUT or THRU), then press the dial.

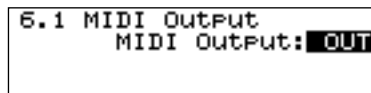

4. When the prompt appears on the screen, press the ENTER button to enable the settings.

To quit without making the settings, use the SELECT dial to choose "NO," then press the ENTER button.

Once the settings have been successfully modified, you're returned to the setting item selection screen.

5. Press the MODE button.

This ends the setting process and returns you to the usual screen.

* If you press the MODE button while making settings, a message asking you to confirm that you want to exit the setting process appears. Note that if you choose "YES," then press the ENTER button, you are returned to the usual screen, and all setting changes you've made up to that point will be discarded.

Device-specific ID (MIDI Device ID) Settings

This sets the MIDI device ID (from 1 through 32).

When you are controlling the unit using MMC, you need to set both devices to matching device ID numbers. Check the device ID of the connected external MIDI instrument, then set the unit to the same device ID.

Procedure for Setting the MIDI Device ID

1. Press the MODE button.

The MODE indicator lights up.

2. Use the SELECT dial to choose "6.7 MIDI Device ID," then press the dial.
3. Turn the SELECT dial to choose the MIDI Device ID (from 1 to 32), then press the dial.

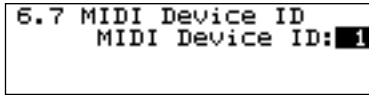

4. When the prompt appears on the screen, press the ENTER button to enable the settings.

To quit without making the settings, use the SELECT dial to choose "NO," then press the ENTER button.

Once the settings have been successfully modified, you're returned to the setting item selection screen.

5. Press the MODE button.

This ends the setting process and returns you to the usual screen.

** If you press the MODE button while making settings, a message asking you to confirm that you want to exit the setting process appears. Note that if you choose "YES," then press the ENTER button, you are returned to the usual screen, and all setting changes you've made up to that point will be discarded.*

MMC mode (OFF/MASTER/SLAVE)

This selects master or slave for MMC synchronization.

OFF: MMC information is not sent or received.

MASTER: MMC information is sent. The unit becomes the master of the external MIDI instrument.

SLAVE: MMC information is received. The unit becomes the slave of the external MIDI instrument.

Procedure for Setting the MMC Mode

1. Press the MODE button.

The MODE indicator lights up.

2. Use the SELECT dial to choose "6.8 MMC Mode," then press the dial.
3. Turn the SELECT dial to choose the MMC Mode (OFF, MASTER, or SLAVE), then press the dial.

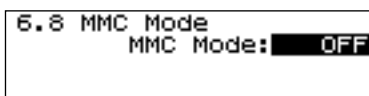

4. When the prompt appears on the screen, press the ENTER button to enable the settings.

To quit without making the settings, use the SELECT dial to choose "NO," then press the ENTER button.

Once the settings have been successfully modified, you're returned to the setting item selection screen.

5. Press the MODE button.

This ends the setting process and returns you to the usual screen.

** If you press the MODE button while making settings, a message asking you to confirm that you want to exit the setting process appears. Note that if you choose "YES," then press the ENTER button, you are returned to the usual screen, and all setting changes you've made up to that point will be discarded.*

Selecting the Sync Source (INTERNAL or MTC)

This sets the Sync Source. For MMC synchronization, set this to "INTERNAL."

INTERNAL: The slave device operates according to the AR-3000R's internal clock.

MTC: The unit operates according to MIDI time code information from the master device.



Note that when Sync Source is set to MTC, there is no operation unless MTC information is input from the external MIDI instrument.

Procedure for Setting the Sync Source

1. Press the MODE button.

The MODE indicator lights up.

2. Use the SELECT dial to choose "6.9 MTC," then press the dial.
3. Turn the SELECT dial to set Sync Source to "INTERNAL," then press the dial.

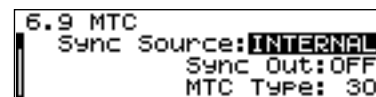

- If you are continuing by making the setting for "Sync Out," proceed to step 4 of the procedure for setting sync out (p. 117).

To finish making the setting, press the ENTER button.

4. When the prompt appears on the screen, press the ENTER button to enable the settings.

To quit without making the settings, use the SELECT dial to choose "NO," then press the ENTER button.

Once the settings have been successfully modified, you're returned to the setting item selection screen.

5. Press the MODE button.

This ends the setting process and returns you to the usual screen.

* If you press the MODE button while making settings, a message asking you to confirm that you want to exit the setting process appears. Note that if you choose "YES," then press the ENTER button, you are returned to the usual screen, and all setting changes you've made up to that point will be discarded.

Operation Procedures

MMC Slave

When you have finished making the settings, operate the connected master device. You can control the unit remotely.

MMC Master

When you have finished making the settings, operate the unit. You can control the connected slave device remotely.

Synchronizing Operation to an External MIDI Instrument – 2 (MMC and MTC)

What Is MTC?/Synchronized Playback with Video Equipment and Other Devices

What Is MTC (MIDI Time Code)?

This comprises MIDI messages developed to allow MIDI devices to be synchronized with precision. It differs from MIDI Clock in that it displays the absolute time. The master device transmits the current absolute time (in hours/minutes/seconds/frames from the start), and the time of the slave device is advanced to conform with it. Use of MMC signals requires that the other device is capable of synchronization using MTC.

With the AR-3000R, you can combine MMC and MTC signals to synchronize playback of audio phrases with a digital mixer, video equipment, or other devices.

Types of MTC (Frame Rate)

The MTC types (frame rates) you can select with the AR-3000R are shown below. When you are synchronizing operation using MTC, you need to set both devices to matching frame rates. Check the specifications of the connected external MIDI instrument, then make the settings.

30: This is 30 frames per second, non-drop format. It is used for audio equipment such as analog tape recorders, and NTSC-format black and white video.

29N: This is 29.97 frames per second, non-drop format. It is used for NTSC-format color video.

29D: This is 29.97 frames per second, drop format. It is used for NTSC-format color video for broadcast use.

25: This is 25 frames per second. It is used for SECAM- and PAL-format video and audio equipment, and for motion pictures.

24: This is 24 frames per second. It is used for video and audio equipment in the U.S.A., and for motion pictures.



Selection of MTC Type (30/29N/29D/25/24) → p. 115

Drop Frame and Non-drop Frame

There are two types of time codes used by NTSC-format video-cassette recorders: drop frame, in which time codes are not continuous, and non-drop frame, in which time codes are continuous. To achieve compatibility with the NTSC color video standard, drop frame drops the first two frames of every minute except the 10th, 20th, 30th, 40th, and 50th minutes.

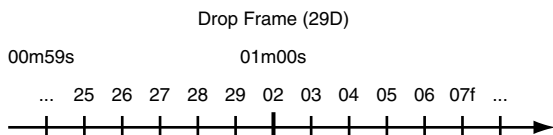
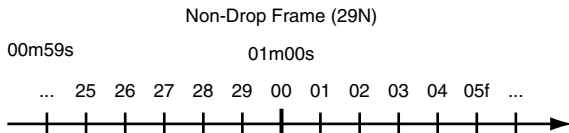

Because continuous frames are easier to work with, non-drop frame is used in general video and music production. Conversely, drop frame is used in television stations and the like, where time codes must match actual clock times.

NOTE

Synchronization by means of MTC is not possible when the Dual Mono mode on the AR-3000R is set to "ON."

NOTE

MTC synchronization may not be correct when Loop Play for a phrase is set to "ON." In such cases, use with Loop Play set to "OFF."

NOTE

Synchronization with MTC is not possible for phrases for which MODE2 is set to RDAC-MODE.

Connecting External Equipment

You can use the AR-3000R as an MTC master or as an MTC slave. In this connection example, the unit is used as a slave.

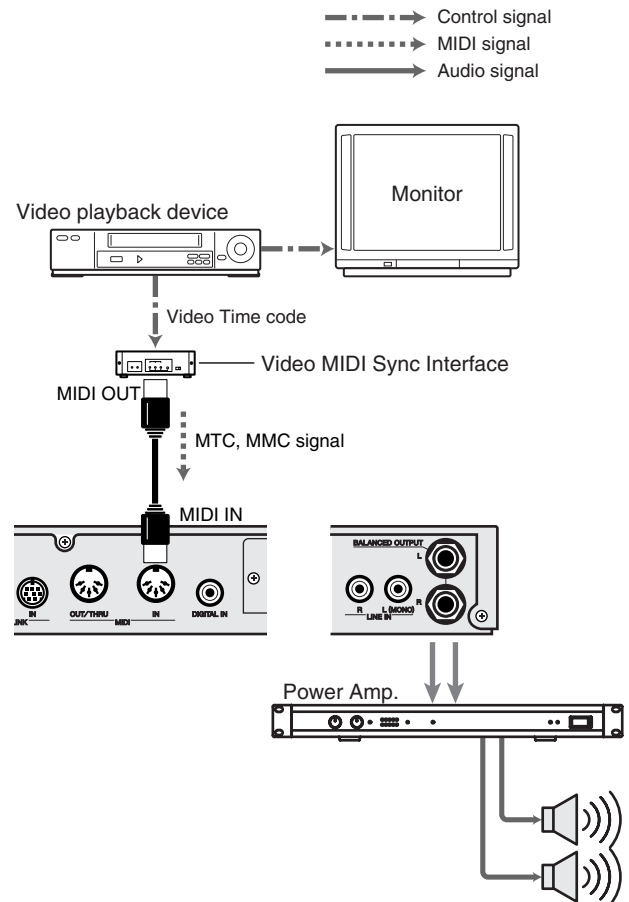

You can play back audio phrases in sync with video. Fast forwarding, rewinding, and playback from whatever position you want is also supported.



Turning the Power On and Off → p. 24

AR-3000R Settings (When the AR-3000R Is the Slave)

Selection of MIDI Output (MIDI OUT or MIDI THRU)

This switches the functioning of the MIDI output connector.

OUT: This sends MIDI information from the unit. Select this when you want to play back MIDI phrases or send Exclusive (SysEx) messages.

THRU: This takes MIDI information from MIDI IN and sends it out unchanged. MIDI information from the AR-3000R itself is not output.

Controlling the AR-3000R Using MIDI Signals (MIDI Control)

Procedure for Setting MIDI Output

1. Press the MODE button.

The MODE indicator lights up.

2. Use the SELECT dial to choose "6.1 MIDI Output," then press the dial.
3. Turn the SELECT dial to set MIDI Output to "THRU," then press the dial.

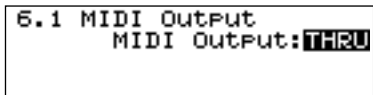

```
6.1 MIDI Output
MIDI Output: THRU
```

4. When the prompt appears on the screen, press the ENTER button to enable the settings.

To quit without making the settings, use the SELECT dial to choose "NO," then press the ENTER button.

Once the settings have been successfully modified, you're returned to the setting item selection screen.

5. Press the MODE button.

This ends the setting process and returns you to the usual screen.

* If you press the MODE button while making settings, a message asking you to confirm that you want to exit the setting process appears. Note that if you choose "YES," then press the ENTER button, you are returned to the usual screen, and all setting changes you've made up to that point will be discarded.

Device-specific ID (MIDI Device ID) Settings

This sets the MIDI device ID (from 1 through 32). When you are controlling the unit using MMC and MTC, you need to set both devices to matching device ID numbers. Check the device ID of the connected external MIDI instrument, then set the unit to the same device ID.

Procedure for Setting the MIDI Device ID

1. Press the MODE button.

The MODE indicator lights up.

2. Use the SELECT dial to choose "6.6 MIDI Device ID," then press the dial.
3. Turn the SELECT dial to choose the MIDI Device ID (from 1 to 32), then press the dial.

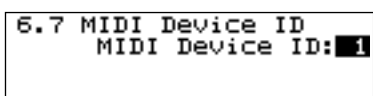

```
6.7 MIDI Device ID
MIDI Device ID: 1
```

4. When the prompt appears on the screen, press the ENTER button to enable the settings.

To quit without making the settings, use the SELECT dial to

choose "NO," then press the ENTER button.

Once the settings have been successfully modified, you're returned to the setting item selection screen.

5. Press the MODE button.

This ends the setting process and returns you to the usual screen.

* If you press the MODE button while making settings, a message asking you to confirm that you want to exit the setting process appears. Note that if you choose "YES," then press the ENTER button, you are returned to the usual screen, and all setting changes you've made up to that point will be discarded.

MMC Mode (OFF/MASTER/SLAVE)

This sets the MMC mode to "SLAVE."

OFF: MMC information is not sent or received.

MASTER: MMC information is sent. The unit becomes the master of the external MIDI instrument.

SLAVE: MMC information is received. The unit becomes the slave of the external MIDI instrument.

Procedure for Setting the MMC Mode

1. Press the MODE button.

The MODE indicator lights up.

2. Use the SELECT dial to choose "6.7 MMC Mode," then press the dial.
3. Turn the SELECT dial to set the MMC Mode to "SLAVE," then press the dial.

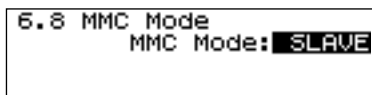

```
6.8 MMC Mode
MMC Mode: SLAVE
```

4. When the prompt appears on the screen, press the ENTER button to enable the settings.

To quit without making the settings, use the SELECT dial to choose "NO," then press the ENTER button.

Once the settings have been successfully modified, you're returned to the setting item selection screen.

5. Press the MODE button.

This ends the setting process and returns you to the usual screen.

* If you press the MODE button while making settings, a message asking you to confirm that you want to exit the setting process appears. Note that if you choose "YES," then press the ENTER button, you are returned to the usual screen, and all setting changes you've made up to that point will be discarded.

Selecting the Sync Source (INTERNAL or MTC)

This sets the Sync Source to "MTC."

INTERNAL: The slave device operates according to the AR-3000R's internal clock. Select this to make the unit the master.

MTC: The unit operates according to MIDI time code information from the master device. Select this to make the unit the slave.



Note that when Sync Source is set to MTC, there is no operation unless MTC information is input from the external MIDI instrument.

Procedure for Setting the Sync Source

1. Press the MODE button.

The MODE indicator lights up.

2. Use the SELECT dial to choose "6.9 MTC," then press the dial.
3. Turn the SELECT dial to set the Sync Source to "MTC," then press the dial.

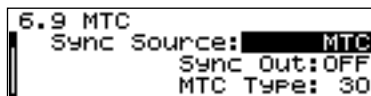

- If you are continuing by making the setting for "Sync Out," proceed to step 4 of the procedure for setting Sync Out (p. 117).

To finish making the setting, press the ENTER button.

4. When the prompt appears on the screen, press the ENTER button to enable the settings.

To quit without making the settings, use the SELECT dial to choose "NO," then press the ENTER button.

Once the settings have been successfully modified, you're returned to the setting item selection screen.

5. Press the MODE button.

This ends the setting process and returns you to the usual screen.

- * If you press the MODE button while making settings, a message asking you to confirm that you want to exit the setting process appears. Note that if you choose "YES," then press the ENTER button, you are returned to the usual screen, and all setting changes you've made up to that point will be discarded.

Selecting the MTC Type (30/29N/29D/25/24)

This selects the MTC type (frame rate).

Check the specifications of the connected external MIDI instrument, then make the settings.



Types of MTC (Frame Rates) → p. 112

Procedure for Setting the MTC Type

1. Press the MODE button.

The MODE indicator lights up.

2. Use the SELECT dial to choose "6.9 MTC," then press the dial.
3. Press the SELECT dial to advance the input location (highlighted) to "MTC Type."
4. Turn the SELECT dial to choose the MTC type (30, 29N, 29D, 25, or 24), then press the dial.

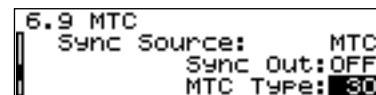

- If you are continuing by making the setting for "MTC Error Level," proceed to step 4 of the procedure for setting the MTC Error Level (p. 115).

To finish making the setting, press the ENTER button.

5. When the prompt appears on the screen, press the ENTER button to enable the settings.

To quit without making the settings, use the SELECT dial to choose "NO," then press the ENTER button.

Once the settings have been successfully modified, you're returned to the setting item selection screen.

6. Press the MODE button.

This ends the setting process and returns you to the usual screen.

- * While making the settings, you can go back to the previous entry position (highlighted) by using the PAUSE (BACK) button.
- * If you press the MODE button while making settings, a message asking you to confirm that you want to exit the setting process appears. Note that if you choose "YES," then press the ENTER button, you are returned to the usual screen, and all setting changes you've made up to that point will be discarded.

Selecting the MTC Error Level (0 to 10)

This sets the interval at which the MTC reception status is checked (from 0 to 10). When you are conducting synchronization with the unit as the slave, this constantly checks whether the unit is correctly sending MIDI time codes. When MIDI time codes are not sent continuously, it is determined that there is a problem with MTC synchronization, and synchronized operation stops.

The MTC error level sets the reference standard for this determination. Larger values increase the degree of error tolerance, making slave playback possible even when there are minor problems in receiving MIDI time codes.

Controlling the AR-3000R Using MIDI Signals (MIDI Control)

Procedure for Setting the MTC Error Level

1. Press the MODE button.
The MODE indicator lights up.
2. Use the SELECT dial to choose "6.9 MTC," then press the dial.
3. Press the SELECT dial to advance the input location (highlighted) to "MTC Error Level."
4. Turn the SELECT dial to choose the MTC Error Level (from 0 to 10), then press the dial.

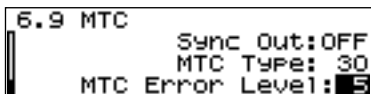

```
6.9 MTC
          Sync Out: OFF
          MTC Type: 30
          MTC Error Level: 5
```

5. When the prompt appears on the screen, press the ENTER button to enable the settings.
To quit without making the settings, use the SELECT dial to choose "NO," then press the ENTER button.
Once the settings have been successfully modified, you're returned to the setting item selection screen.
6. Press the MODE button.
This ends the setting process and returns you to the usual screen.
 - * While making the settings, you can go back to the previous entry position (highlighted) by using the PAUSE (BACK) button.
 - * If you press the MODE button while making settings, a message asking you to confirm that you want to exit the setting process appears. Note that if you choose "YES," then press the ENTER button, you are returned to the usual screen, and all setting changes you've made up to that point will be discarded.

Operation Procedures

When you have finished making the settings, carry out playback on the connected master device. Phrase playback in sync with received MIDI time codes starts.

When Sync Source is set to MTC, the indicators on the front panel of the unit light up as shown below.

	PLAY button	PAUSE button
During Pause	Lights in green	Lights in orange
During Rec standby	Lights in red	Lights in orange

- Playback is paused when MTC (Full messages; p. 139) is received, or the PLAY button is pressed.
- To enter recording standby under the control of MTC, press the PLAY button while holding down the STOP button, then press the PAUSE button again.

A screen like the following appears during playback.

Remaining time for phrase playback



```
A0001 AR-3000 1
00h00m15s03f
MTC 00h00m00s04f
```

MIDI Time Code

NOTE

Note that there is no operation unless MIDI time codes are input from the external MIDI instrument.

AR-3000R Settings (When the AR-3000R Is the Master)

Selection of MIDI Output (MIDI OUT or MIDI THRU)

This switches the functioning of the MIDI output connector. Here, select "OUT."

OUT: This sends MIDI information from the unit. Select this when you want to play back MIDI phrases, send Exclusive (SysEx) messages, or make the AR-3000R the master during synchronization using MIDI signals.

THRU: This takes MIDI information from MIDI IN and sends it out unchanged. MIDI information from the AR-3000R itself is not output.

Procedure for Setting MIDI Output (MIDI OUT or MIDI THRU)

For setting procedure, refer to p. 110.

Device-specific ID (MIDI Device ID) Settings

This sets the MIDI device ID (from 1 through 32). When you are controlling an external MIDI instrument using MMC and MTC, you need to set both devices to matching device ID numbers. Check the device ID of the connected external MIDI instrument, then set the unit to the same device ID.

Procedure for Setting the MIDI Device ID

For setting procedure, refer to p. 114.

MMC mode (OFF/MASTER/SLAVE)

This sets the MMC Mode to "MASTER."

OFF: MMC information is not sent or received.

MASTER: MMC information is sent. The unit becomes the master of the external MIDI instrument.

SLAVE: MMC information is received. The unit becomes the slave of the external MIDI instrument.

Procedure for Setting the MMC Mode

For setting procedure, refer to p. 111.

Selecting the Sync Source (INTERNAL or MTC)

This sets the Sync Source to "INTERNAL."

INTERNAL: The slave device operates according to the AR-3000R's internal time control. Select this to make the unit the master.

MTC: The unit operates according to MIDI time code information from the master device. Select this to make the unit the slave.



Note that when Sync Source is set to "MTC," there is no operation unless MTC information is input from the external MIDI instrument.

Procedure for Setting the Sync Source

For setting procedure, refer to p. 111.

Selecting Sync Out (OFF or MTC)

This sets Sync Out to "MTC."

OFF: MIDI time codes are not sent.

MTC: MIDI time codes are sent. Select this when you are operating a slave device using the unit's MTC.

Procedure for Setting Sync Out

1. Press the MODE button.

The MODE indicator lights up.

2. Use the SELECT dial to choose "6.9 MTC," then press the dial.
3. Press the SELECT dial to advance the input location (highlighted) to "Sync Out."
4. Turn the SELECT dial to set Sync Out to "MTC," then press the dial.

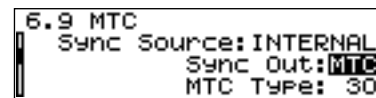

- If you are continuing by making the setting for "MTC Type," proceed to step 4 of the procedure for setting the MTC Type (p. 115).

To finish making the setting, press the ENTER button.

5. When the prompt appears on the screen, press the ENTER button to enable the settings.

To quit without making the settings, use the SELECT dial to choose "NO," then press the ENTER button.

Once the settings have been successfully modified, you're returned to the setting item selection screen.

6. Press the MODE button.

This ends the setting process and returns you to the usual screen.

- * While making the settings, you can go back to the previous entry position (highlighted) by using the PAUSE (BACK) button.
- * If you press the MODE button while making settings, a message asking you to confirm that you want to exit the setting process appears. Note that if you choose "YES," then press the ENTER button, you are returned to the usual screen, and all setting changes you've made up to that point will be discarded.

Selecting the MTC Type (30/29N/29D/25/24)

This selects the MTC type (frame rate).

Check the specifications of the connected external MIDI instrument, then make the settings.



Types of MTC (Frame Rates) → p. 112

Procedure for Setting the MTC Type

For setting procedure, refer to p. 115.

Operation Procedures

When you have finished making the settings, play back a phrase on the unit. The connected slave device carries out synchronized playback.

MTC Offset Setting

This adjusts the timing when you are using MTC to synchronize operation of the unit and an external MIDI instrument.

Settings When Synchronizing Operation of the Unit to the MIDI Time Code from an External MIDI Instrument

When you're operating the unit on receiving the MIDI Time Code from an external MIDI instrument, you can effect playback on the unit at any time you want.

For instance, if you want to play back a phrase when the MTC time on the external MIDI instrument is "01h00m00s00f," set the offset to "01h00m00s00f."

Settings When Synchronizing an External MIDI Instrument to the MIDI Time Code from the Unit

When you're operating an external instrument on receiving the MIDI Time Code from the unit, you can effect playback on the external instrument at any time you want.

For instance, if you want to play back a phrase on the unit, then after the elapse of "00h00m10s00f" effect playback on the external MIDI instrument at "00h00m00s00f," set the offset to "23h59m50s00f."

"00h00m00s00f" - "00h00m10s00f" = "23h59m50s00f"

When the calculated time value is negative, add "24h00m00s00f."

Procedure for Setting the MTC Offset

1. Press the MODE button.
2. Use the SELECT dial to choose "6.9 MTC," then press the dial.
3. Press the SELECT dial and advance the entry location (highlighted) to "Offset."
4. Turn the SELECT dial to set the offset (time), then press the dial.

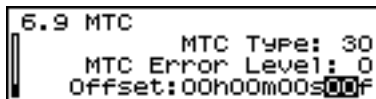

Each press of the BACK button moves the cursor (highlighted) in the sequence of f → s → m → h.

5. When the prompt appears on the screen, press the ENTER button to enable the settings.

To quit without making the settings, use the SELECT dial to choose "NO," then press the ENTER button.

Once the settings have been successfully modified, you're returned to the setting item selection screen.

6. Press the MODE button.

This ends the setting process and returns you to the usual screen.

- * While making the settings, you can go back to the previous entry location (highlighted) by pressing the PAUSE (BACK) button.
- * If you press the MODE button while making settings, a message asking you to confirm that you want to exit the setting process appears. Note that if you choose "YES," then press the ENTER button, you are returned to the usual screen, and all setting changes you've made up to that point will be discarded.

Controlling the AR Using the RS-232C Connector

What's the RS-232C Connector?/ What You Can Do with the RS-232C Connector

The RS-232C connector is a connector used to connect to a computer or other peripheral equipment. The AR-3000R is equipped with a D-sub 9-pin type RS-232C connector. With the AR-3000R, you can control the AR-3000R from an external control device such as a computer or touch panel by means of an RS-232C cable connection.



For more information about examples of using the RS-232C connector, also see "Using the RS-232C Connector" (p. 21).

● Controlling the AR-3000R Using a Computer

You can do things like controlling starting and stopping of recording or playback (for audio recording only), make settings during recording, specify phrases, and copy and delete phrases and cards.



For more about the specifications of the RS-232C connector, see "RS-232C Connector Specifications" in Appendices (p. 137).

Connecting Equipment

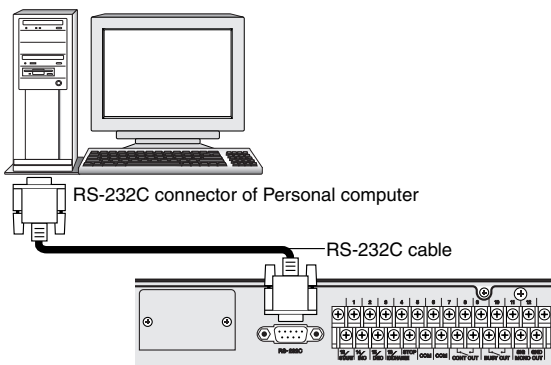

Turning the Power On and Off → p. 24

Baud Rate Setting

Set the RS-232C communication speed (baud rate). The available baud rates are 4800, 9600, 19200 or 38400 bps. Choose one that matches the usage conditions.

- * Be sure to check the baud rate of the computer you're using before making the setting.
- * The setting for 38,400 bps is for compatibility with legacy models (the AR-3000/ 2000). However, it is a value for the communication speed that is not defined by the RS-232C standards. Make this setting as necessary when using a legacy model by means of card conversion.

Procedure for Setting the Baud Rate

1. Press the MODE button.

The MODE indicator lights up.

2. Use the SELECT dial to choose "7.1 Baud Rate," then press the dial.
3. Turn the SELECT dial to choose the Baud Rate (4800, 9600, 19200 or 38400), then press the dial.

```
7.1 Baud Rate
Baud Rate: 4800
```

4. When the prompt appears on the screen, press the ENTER button to enable the setting.

To quit, use the SELECT dial to choose "NO," then press the ENTER button.

When you're finished making the setting, the display returns to the setting item selection screen.

5. Press the MODE button.

This ends the setting process and returns you to the usual screen.

- * Pressing the MODE button while making the setting displays a prompt asking you whether you want to quit making the setting. Note that choosing "YES" and pressing the ENTER button returns you to the usual screen, discarding any settings made up to that point.

Available Documentation for the RS-232C

In addition to the owner's manual, "RS-232C Reference Notes" are available for purchase as reference materials that cover RS-232C connector control. The PDF file can be downloaded free of charge from the following URL.

- The RS-232C Reference Notes cover the following topics:
 - Setup
 - Overviews, detailed descriptions, and lists of commands
 - Examples of usage algorithms

<http://www.rssamerica.com/>

Playing Two Units's Worth of Data on the Left and Right (Dual Mono Mode)

What Is the Dual Mono Mode?/ Equipment Connections

The Dual Mono mode is a feature for playing different mono audio phrases independently on the left and right channels.

By playing odd-numbered phrases (A0001, A0003,... or B0001, B0003,...) from the left channel and even-numbered phrases (A0002, A0004,... or B0002, B0004,...) from the right channel, you can play back two units's worth of data on a single unit.

You can also play back separate phrases on the left and right channels either simultaneously, or shifted.

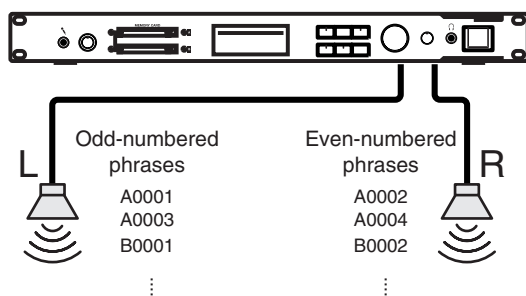

Note that the Dual Mono mode is subject to various conditions that you should be aware of before you use the mode.

MEMO

On the AR-2000/100 (legacy models), this Dual Mono mode is named the "Channel Playback mode." As you use it, keep in mind that it is the same feature.

Conditions for Simultaneous Playback in Dual Mono Mode

- Phrases Whose Recording Type Is Mono
- RDAC-Grade and RDAC-Mode Must Be Uniform

Specifying Phrases Like the Following Result in Dual Mono Mode Playback That May Not Be Correct

- MIDI Phrases, Song Phrases
 - These are treated as empty phrases.
- Pattern Phrases Containing MIDI Phrases
 - These are treated as empty phrases, and the unit searches for and plays back the next phrase.
- Phrases Whose Recording Type Is Stereo
 - Dual Mono playback is canceled, and the specified phrase is output in stereo (L/R).
- Phrases for Which RDAC-Grade and RDAC-Mode Are Different
 - The phrase already being played back is stopped, and the next specified phrase is played.

If a phrase unsuited to Dual Mono playback is specified on either the left or right channel in the course of sequential phrase playback, it results in incorrect Dual Mono playback. To ensure reliable Dual Mono playback, specify the playback phrases with care.

HINT

Dual Mono playback can be made possible by converting stereo phrases to mono phrases. You can also make Dual Mono playback possible for phrases having different RDAC-modes by converting them after recording to make them uniform. For more about how to convert phrases, refer to "Phrase Convert" (p. 78).

The following phrase information has no effect during playback.

- 1.5 Loop Play

Control Output During Dual Mono Mode Playback

During Dual Mono mode playback, the left-channel Busy Out signal is output from the BUSY OUT control port, and the right-channel Busy Out signal is output from the CONT OUT control port.

- * Note that no Control Out signal is output (because the Control Out setting (p. 59) is not valid).

AR-3000R Settings

Set the Dual Mono Mode to "ON (MONO 2ch)."

Procedure for Setting the Dual Mono Mode

1. Press the MODE button.
The MODE indicator lights up.
2. Use the SELECT dial to choose "9.1 Dual Mono Mode," then press the dial.
3. Turn the SELECT dial to choose Dual Mono Mode (ON (MONO 2ch)), then press the dial.

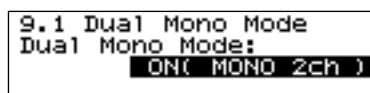

4. When the prompt appears on the screen, press the ENTER button to enable the settings.

To quit without making the settings, use the SELECT dial to choose "NO," then press the ENTER button.

When you're finished making the setting, the display returns to the setting item selection screen.

5. Press the MODE button.

This ends the setting process and returns you to the usual screen.

Playing Two Units's Worth of Data on the Left and Right

* If you press the MODE button while making settings, a message asking you to confirm that you want to exit the setting process appears. Note that if you choose "YES," then press the ENTER button, you are returned to the usual screen, and all setting changes you've made up to that point will be discarded.

Operation Procedures

Dual Mono Playback Through Manual Operation

You can perform manual playback, in the same way as for ordinary stereo playback.

1. Insert a card containing recorded information into a slot.
2. Turn the SELECT dial to choose the phrase number to play.



* To switch between card slots A and B, press the SELECT dial.
 * To switch between L (left) and R (right), press the ENTER button.

3.
 - Pressing the PLAY button plays back a phrase. During playback of the phrase, the PLAY indicator lights up in green.
 - * The phrase whose phrase number is highlighted is played back.
 - Pressing the STOP button ends playback.
 - During playback, you can choose the next song to play (without stopping the phrase being played) by turning the SELECT dial.



Please be aware that you cannot pause Dual Mono playback.

Dual Mono Playback Through Control Input

You can perform playback through control input, in the same way as for ordinary stereo playback.
 The settings for control-input playback basically act independently for each channel.



For more information about the operation of playback with control input terminals, see also "Controlling the AR-3000R from an External Device (Control Input)" (p. 85).

During Direct Playback

Odd-numbered phrases are output by direct playback from output L (left), and even-numbered phrases are output by direct playback from output R (right). The order of priority of the control input connectors may vary depending on how phrases are assigned to the control input terminals. To facilitate understanding, the explanations in this section assume that the assigned phrase numbers correspond to the port numbers.

Port No.	1	2	3	4	5	...	16
Phrase	A0001	A0002	A0003	A0004	A0005	...	A0016
Output jack	L	R	L	R	L	...	R

When you send a Stop input signal, playback stops simultaneously for the L and R channels.

- * Input a trigger signal to the control signal.
- * Do not simultaneously input more than one control input allocated to the same output.

● Normal Playback

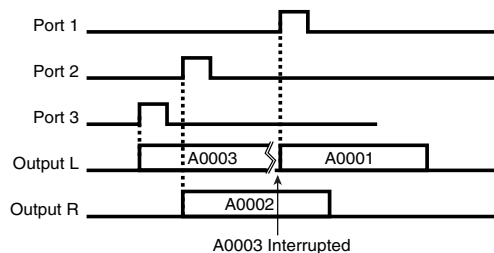

- Because port Nos. 1 and 3 are allocated to output L, depending on the port priority, playback of A0003 is halted and A0001 is played.
- Because port No. 2 is allocated to output R, A0002 continues to be played back even during playback of A0003 or A0001.

● First-In Playback

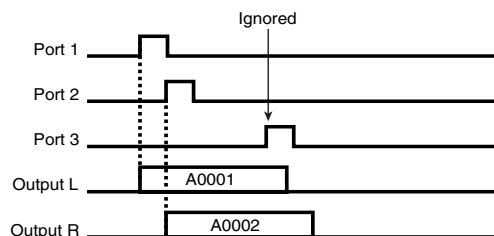

- Because port Nos. 1 and 3 are allocated to output L, depending on the port priority, signals input to 3 are not valid.
- Because port No. 2 is allocated to output R, A0002 is played back even during playback of A0001.

Applications

Playing Two Units's Worth of Data on the Left and Right

● Last-In Playback

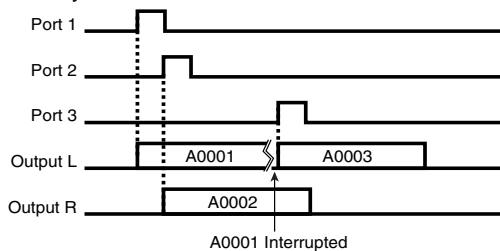

- Because port Nos. 1 and 3 are allocated to output L, depending on the port priority, playback of A0001 is halted and A0003 is played back.
- Because port No. 2 is allocated to output R, A0002 continues to be played back even during playback of A0003 or A0001.

● Sequence Playback

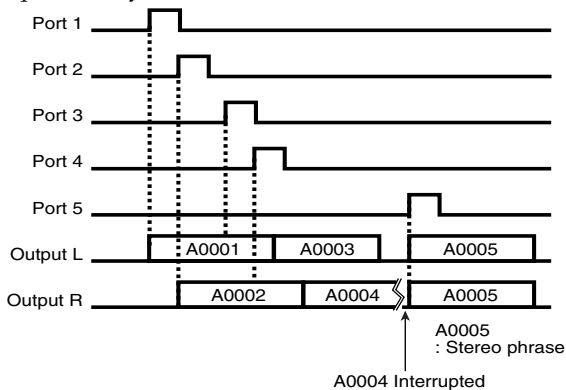

- The control signals for port Nos. 3 and 4 are stored in memory (reserved), and after playback of A0001 and A0002 ends, A0003 and A0004 are played.
- Because A0005 is a stereo phrase, playback of A0004 is stopped, and the specified phrase is played back in stereo (left and right).

During Program Playback

Odd-numbered phrases are output by program playback from output L (left), and even-numbered phrases are output by program playback from output R (right).

- * Because Start signals are ignored during playback of one phrase, simultaneous playback of output L and R is not possible.

When you send a Stop input signal, playback stops simultaneously for the L and R channels.

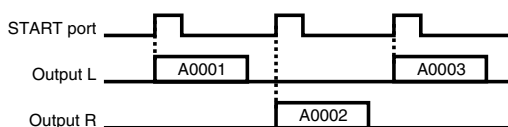

During Binary Playback

Odd-numbered phrases are output by binary playback from output L (left), and even-numbered phrases are output by binary playback from output R (right).

When you send a Stop input signal, playback stops simultaneously for the L and R channels.

● When Level is set to "ON" and Edge is set to "OFF"

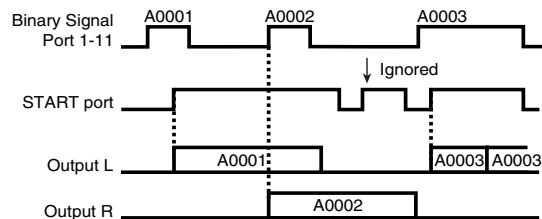

- Any new Start signal input during A0002 playback is not valid.
- Playback is repeated while binary is specified for A0003 and the Start signal is continuously input.

● When Level is set to "OFF" and Edge is set to "ON"

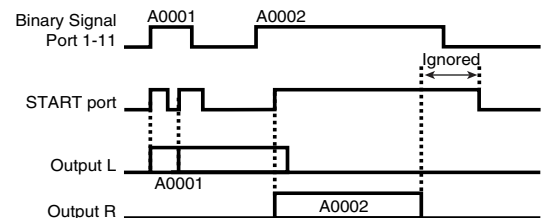

- A0001 is played back only once.
- A0002 is played back only once, then ends, even when binary is specified for A0002 and the Start signal is continuously input.

Dual Mono Playback Through MIDI Signals

You can perform playback through MIDI signals, in the same way as for ordinary stereo playback. Playback starts when a MIDI Note On message is received. Odd-numbered phrases are played back from the L (left) channel, and even-numbered phrases are played back from the R (right) channel.

- * Because playback is performed in reverse priority, the last-receive Note On message takes priority.
- * Setting Note Trigger to "Gate" makes it possible to send stop instructions independently to the left and right channels.

Dual Mono Playback Through the RS-232C Connector

In a manner similar to ordinary stereo playback, you can also obtain playback through the RS-232C connector. Phrase playback-sequence information is allocated to the corresponding dedicated buffer according to whether the phrase number is odd or even, and playback on the left and right channels starts simultaneously according to the respective playback sequence.

- * Sending a playback-stop instruction stops playback simultaneously on the left and right channels.

Synchronized Recording and Playback with Multiple AR Units (AR-LINK)

What Is AR-LINK?/What You Can Do Using AR-LINK

The AR-LINK connector is a special transmission connector for AR units, used for creating completely synchronized recording and playback with multiple AR-3000R devices. The connectors feature special leads for commands and master clock, allowing synchronization with sampling frequency precision.

With one AR-3000R as the master, you can link up to 31 other AR-3000R/3000/200 units (for a total of 32 devices) to get 64-channel multitrack recording and playback.

However, this system allow recording and playback only of audio phrases (Song phrases, Pattern phrases, and MIDI phrases cannot be handled).

Synchronized Audio Phrase Playback with AR-LINK Signals

Example of Connecting to an External Device

- Use MIDI to send a hard disk recorder's operation data to the master AR-3000R. Connecting four slave AR units in a chain then allows you to get 8-channel multitrack recording.

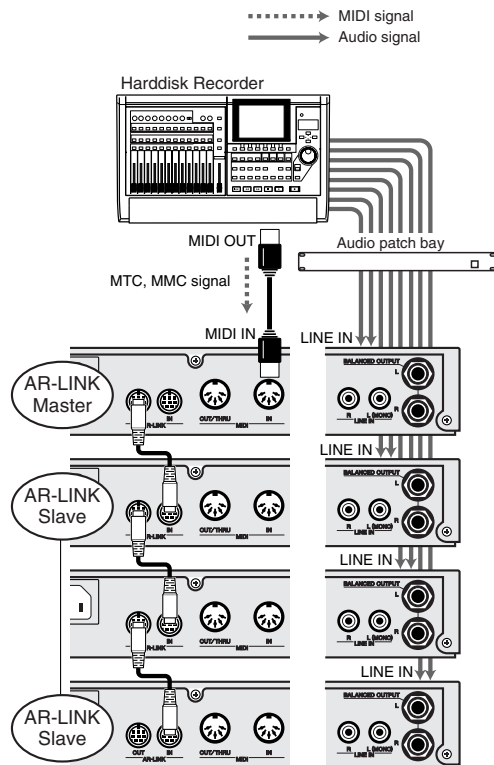

- Use MIDI to send signals from a video device to the master AR-3000R. You can chain 31 slave AR units to synchronize images and phrases.

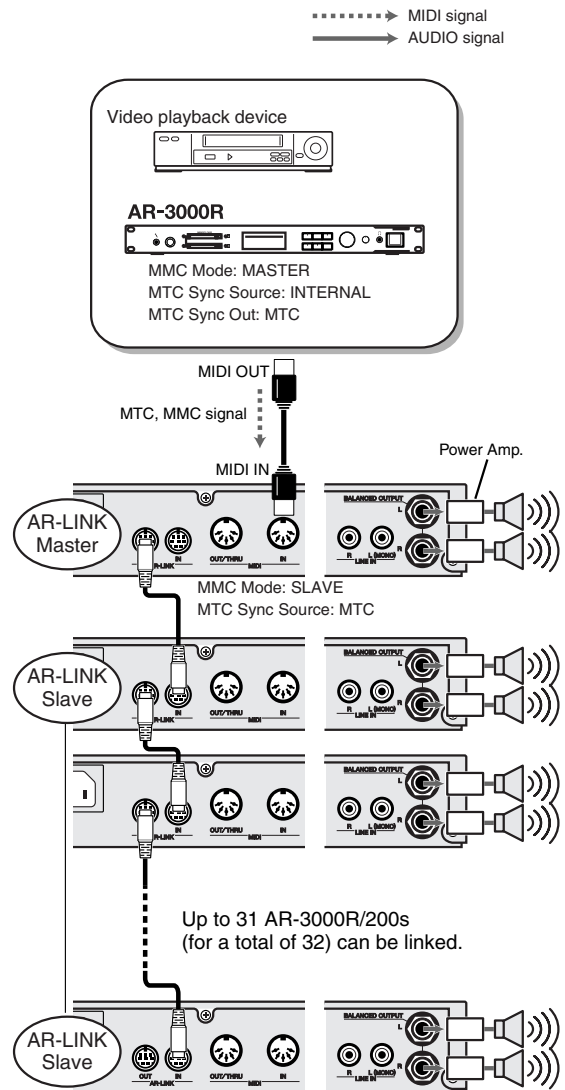

Also refer to "Synchronizing Operation to an External MIDI Instrument - 2 (MMC and MTC)" (p. 112).

NOTE

Do not connect a cable to AR-LINK IN on the AR-3000R set as the master.

NOTE

When an AR-200 is serving as a slave, AR-LINK synchronization cannot be accomplished if the master chooses a B slot phrase.

NOTE

During AR-LINK playback, the "Repeat Play," "Loop Play," and "Control Out" settings made for the phrases have no effect.

Unit Settings

Setting the AR-LINK Mode

OFF: There is no synchronization using AR-LINK. Even when this is set to Off, signals input to AR-LINK IN are output from AR-LINK OUT.

MASTER: This enables operation as the AR-LINK master.

SLAVE: This enables operation as the AR-LINK slave. Use this settings for the second and later AR units connected using AR-LINK.

Procedure for Setting the AR-LINK Mode

1. Press the MODE button.

The MODE indicator lights up.

2. Use the SELECT dial to choose "8.1 AR-LINK Mode," then press the dial.
3. Turn the SELECT dial to choose the AR-LINK Mode (OFF, MASTER, or SLAVE), then press the dial.

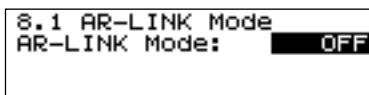

4. When the prompt appears on the screen, press the ENTER button to enable the settings.

To quit without making the settings, use the SELECT dial to choose "NO," then press the ENTER button.

Once the settings have been successfully modified, you're returned to the setting item selection screen.

5. Press the MODE button.

This ends the setting process and returns you to the usual screen.

- * If you press the MODE button while making settings, a message asking you to confirm that you want to exit the setting process appears. Note that if you choose "YES," then press the ENTER button, you are returned to the usual screen, and all setting changes you've made up to that point will be discarded.



Recording Procedure

For the master, these are the same as the usual recording procedure (p. 41) and recording settings (p. 42). The slave AR units operate according to the operation of the master.

REC Standby
(Slave)

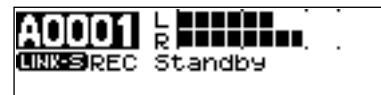

During recording
(Slave)



- * When you set the master, all slave AR units connected by AR-LINK are set to the same value.
- * During recording, you can stop the slave AR units individually, by operating their respective panels.

Playback Procedure

For the master, this is the same as the usual playing back procedure. The slave AR units operate according to the operation of the master.

During playback
(Master)



- * During playback, you can stop the slave AR units individually, by operating their respective panels.
- * If independent playback is carried out on the slave AR-3000R, the indication for the fact that it is an AR-LINK slave disappears.

NOTE

Phrases used for synchronized AR-LINK playback must all be the same Card Slot, REC Type, RDAC-Grade, and RDAC-Mode. If a card having a different setting than the master is inserted into an AR unit, the AR unit will not operate. In such instances, connected slave AR units thereafter are not affected.

NOTE

Please be aware that a second or subsequent AR unit connected through AR-LINK cannot be set as the master.

NOTE

AR-LINK signals are not sent from the master in cases like the ones below.

- When the Dual Mono mode is "ON"
- When the master is playing back a MIDI phrase, song phrase, or pattern phrase

Other Useful Functions During Phrase Playback

This section highlights some other functions that can be useful when you play phrases. Use them to match the situation.

Line Out (Thru) Setting During Phrase Playback

Handy Uses of Line Thru

With the AR-3000R, you can take audio from LINE IN, mix it during phrase playback, and mixed it from Line Out (or Line Thru).

CD player or other sound playback device

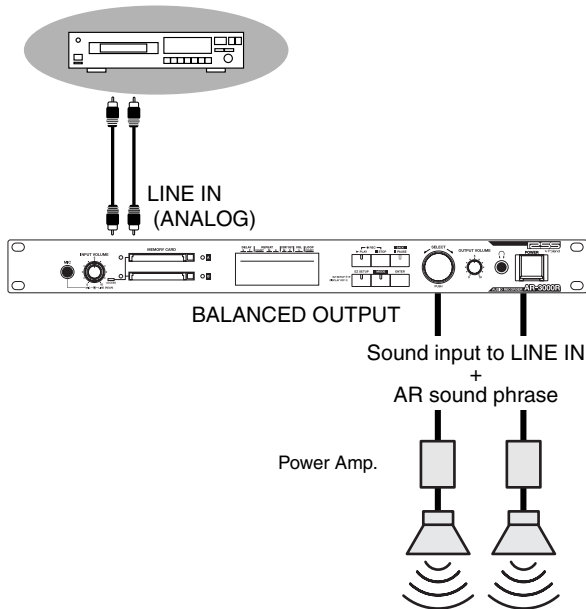

This is useful when you want to do things like taking music from LINE IN and layering it with narration phrases as background music.

You can also make the LINE IN sound fade out or in.



Line throughput is possible only for signals connected to the LINE IN jacks (the DIGITAL IN jack cannot be used for this).

Line Thru Output Specifications

The following output specifications apply, depending on the Line Thru settings.

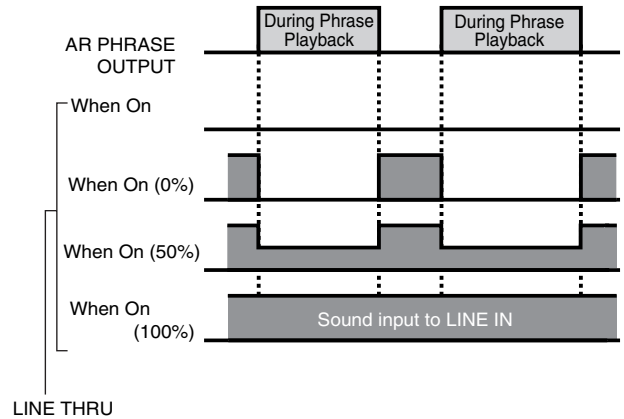

● When fade-out or fade-in settings have been made

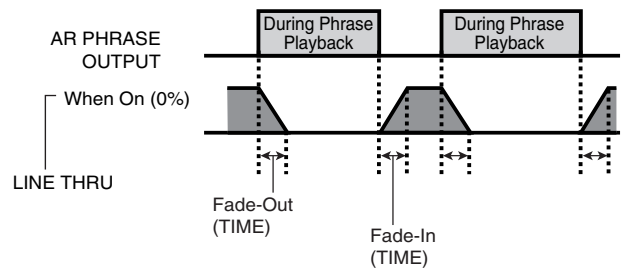

When Using Microphone Input

Audio from the Mic jack is sent to Line Out only during recording or recording standby.

You cannot output audio from the Mic jack during phrase playback or while stopped, even when "ON" is selected for Line Thru.

Line Thru Settings

Make the settings for Line Thru.



Also refer to "Line Thru Output Specifications."

- **Volume:** Set the Line Thru output volume level during phrase playback within the range of 0 to 100%. The throughput volume level output when phrase playback is stopped is 100%. When you set the volume level to 0%, nothing is output to Line Thru during phrase playback.
- * You can make the setting for Thru Volume only when Line Thru is set to "ON."
- **Fade Out:** This makes the Line Thru input fade out when phrase playback starts.
- **Fade In:** This makes the Line Thru input fade in when phrase playback ends.

Other Useful Functions During Phrase Playback

* You can make the setting for Fade Out or Fade In only when Line Thru is set to "ON."

MEMO

While making the Line Thru settings, you can play the phrase selected before you made the settings by pressing the PLAY button. This lets you verify the Line Thru operation as you make the settings.

Procedure for Making Line Thru Settings

1. Press the MODE button.

The MODE indicator lights up.

2. Use the SELECT dial to choose "9.2 Line Thru," then press the dial.

3. Turn the SELECT dial to choose Line Thru (OFF or ON), then press the dial.

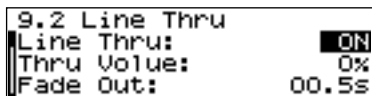

```
9.2 Line Thru
Line Thru:      ON
Thru Volume:    0%
Fade Out:       00.5s
```

4. Turn the SELECT dial to set the Thru Volume (0 to 100%), then press the dial.

* You can make the setting for Thru Volume only when you have selected Line Thru "ON."

5. Turn the SELECT dial to make the setting for Fade Out (time: 00.5 sec to 59.9 sec), then press the dial.

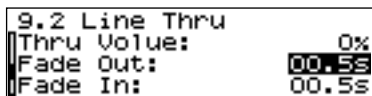

```
9.2 Line Thru
Thru Volume:    0%
Fade Out:       00.5s
Fade In:        00.5s
```

* You can make the setting for Fade Out only when you have selected Line Thru "ON."

6. Turn the SELECT dial to make the setting for Fade In (time: 00.5 sec to 59.9 sec), then press the dial.

* You can make the setting for Fade In only when you have selected Line Thru "ON."

7. When the prompt appears on the screen, press the ENTER button to enable the settings.

To quit without making the settings, use the SELECT dial to choose "No," then press the ENTER button.

8. When the prompt appears on the screen, press the ENTER button to enable the settings.

To quit without making the settings, use the SELECT dial to choose "NO," then press the ENTER button.

When you're finished making the setting, the display returns to the setting item selection screen.

9. Press the MODE button.

This ends the setting process and returns you to the usual screen.

* While making the settings, you can go back to the previous entry position (highlighted) by using the PAUSE (BACK) button.

* Pressing the MODE button while making the setting displays a prompt asking you whether you want to quit making the setting. Note that choosing "YES" and pressing the ENTER button returns you to the usual screen, discarding any settings made up to that point.

Adjusting the Sound Quality During Audio Phrase Playback (Equalizer)

The equalizer can be used to obtain the desired sound quality for the playback of audio phrases. A setting of 0 dB produces flat characteristics (the state of the original sound).

- **Low:** This adjusts the sound quality of the low band. This performs adjustment within a range of -12 dB to +12 dB (Low Gain), with a reference frequency of 200 Hz or 400 Hz.
- **High:** This adjusts the sound quality of the high band. This performs adjustment within a range of -12 dB to +12 dB (High Gain), with a reference frequency of 3 kHz or 6 kHz.
- **Attenuation:** Depending on the equalizer settings, sound may be distorted. If this happens, set Attenuation within a range of -12 dB to 0 dB. However, note that the output level also drops when this value is set to anything other than 0 dB.

HINT

Boosting the level of the low band (by shifting it more toward the plus side) makes the bass more prominent. This produces a heavier, more impressive sound. Lowering the level of the low band (by shifting it more toward the minus side) cuts the bass. This makes narration phrases and the like easier to hear.

HINT

Boosting the level of the high band (by shifting it more toward the plus side) makes the treble more prominent and improves drop-out. Boosting it too much imparts a sharp feel. Lowering the level of the high band (by shifting it more toward the minus side) cuts the treble and produces a milder sound. Lowering it too much imparts a muffled or murky feel.

Procedure for Making the Equalizer Settings

1. Press the MODE button.

The MODE indicator lights up.

2. Use the SELECT dial to choose "9.3 Equalizer," then press the dial.

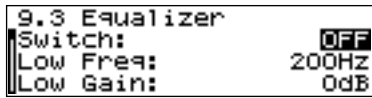

3. Turn the SELECT dial to set Switch to "ON," then press the dial.
4. Turn the SELECT dial to set the Low Freq (to 200 or 400 Hz), then press the dial.
5. Turn the SELECT dial to set the Low Gain (at a value from -12 dB to +12 dB), then press the dial.
6. Turn the SELECT dial to set High Freq (to 3 or 6 kHz), then press the dial.
7. Turn the SELECT dial to set the High Gain (at a value from -12 dB to +12 dB), then press the dial.
8. If distortion is a problem, turn the SELECT dial to make the setting for Attenuation (-12 dB to 0 dB), then press the dial.



You can play back the selected phrase by pressing the PLAY button. This makes it possible to make the setting while monitoring the actual sound quality.

9. When the prompt appears on the screen, press the ENTER button to enable the settings.

To quit without making the settings, use the SELECT dial to choose "NO," then press the ENTER button.

When you're finished making the setting, the display returns to the setting item selection screen.

10. Press the MODE button.

This ends the setting process and returns you to the usual screen.

- * While making the settings, you can go back to the previous entry position (highlighted) by using the PAUSE(BACK) button.
- * Pressing the MODE button while making the setting displays a prompt asking you whether you want to quit making the setting. Note that choosing "YES" and pressing the ENTER button returns you to the usual screen, discarding any settings made up to that point.

Keeping the Output Volume Unchanged (Output Volume Thru)

This deactivates the OUTPUT VOLUME knob and keeps the output volume level unchanged to prevent accidental operation.

- * The OUTPUT VOLUME knob can still be used to adjust the headphones volume and MONO OUT (Control Input/Output Terminals) even when Volume Thru is set to "ON."

OFF: The Output Volume control is effective.

ON: The Output Volume control is deactivated.



When Volume Thru is set to "ON," the volume is fixed at the level obtained when the control is centered (that is, when positioned at 12 o'clock).

Procedure for Making the Output Volume Thru Setting

1. Press the MODE button.
The MODE indicator lights up.
2. Use the SELECT dial to choose "9.4 Output Vol. Thru," then press the dial.
3. Turn the SELECT dial to choose Volume Thru (OFF or ON), then press the dial.

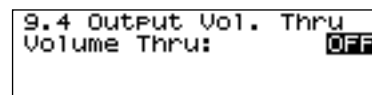

4. When the prompt appears on the screen, press the ENTER button to enable the settings.

To quit without making the settings, use the SELECT dial to choose "NO," then press the ENTER button.

When you're finished making the setting, the display returns to the setting item selection screen.

5. Press the MODE button.

This ends the setting process and returns you to the usual screen.

- * Pressing the MODE button while making the setting displays a prompt asking you whether you want to quit making the setting. Note that choosing "YES" and pressing the ENTER button returns you to the usual screen, discarding any settings made up to that point.

AUDIO RECORDER AR-3000R

Appendices

Troubleshooting

About recording

Can't record a connected device

Has the selection of the recording connector (LINE-IN, LINE+MIC-IN, DIGITAL-IN, or MIDI-IN) been made correctly?

Make sure the device connected to the connector matches the selected recording connector.

→ "Selecting the Recording Connector" (p. 43)

Recording does not start

Is the trigger recording setting set to LOW, MID, or HIGH?

In trigger recording, recording starts automatically when the audio input is of a higher level than the trigger level (level for starting recording).

If you are not conducting trigger recording, set it to "OFF."

→ "Trigger Recording Setting" (p. 48)

About playback

Phrases are not played back correctly

Has the card been formatted on a computer?

Be sure to format cards on an AR series device.

Phrases are not played back (PAUSE indicator lit in orange).

Is the MTC "Sync Source" set to "MTC?"

When not synchronizing playback with MTC and using the AR-3000R as a slave, set "Sync Source" on the AR-3000R to "INTERNAL."

Pattern phrases and song phrases are not played back as intended

When creating a pattern phrase or song phrase, you can choose actual phrases with constituents from both card A and card B. At the time of playback, however, if the card containing the constituent phrases is not inserted, playback will not occur in the normal fashion. (If a constituent phrase is not present, the unit seeks and plays back the next phrase.) Make sure the phrases assigned during creation exist on the cards.

→ "Pattern phrase" (p. 62)

→ "Song phrase" (p. 65)

The start of phrase playback is delayed when playback is controlled from an external device

Has the "Delay Time" been set for the phrase?

Try playing back the phrase by pressing the AR-3000R's PLAY button (manual operation). If the start of playback is delayed, check the AR-3000R to confirm whether or not the delay time has been set.

→ "Delay Time" (p. 55)

If the playback is correct when you press the AR-3000R's PLAY button, check the control signals being sent from the external control device, connections and so on once more.

Control Input Playback (Direct/Program/Binary) does not work as intended

Select the correct type of control input (Direct, Program, or Binary). You cannot achieve control input playback merely by connecting a device to the port. Be sure to set the control input mode and match the method used for connecting to the connectors.

Phrases in Direct Playback cannot be selected as intended

Phrases are assigned to Ports 1 to 16 by means of settings made on the AR-3000R.

When a card is formatted, the assignments are Port No. 1—phrase A0001, Port No. 2—phrase A0002,..., Port No. 16—phrase A0016.

→ "Assigning Phrases to the Ports" (p. 88)

Phrases in Direct Playback do not stop playing.

Check the phrase settings and make sure that "Repeat Play" is not set to "ON."

→ "Repeat Play" (p. 57)

In Program Playback, phrases cannot be selected as intended.

The assignments of phrases in the Program Playback sequence are made with settings on the unit.

When a card is formatted, the assignments are No. 1—phrase A0001, No. 2—phrase A0002,..., No. 100—phrase A0100.

→ "Registering Phrases" (p. 92)

Dual Mono playback does not work as intended.

In the system settings, is "Dual Mono Mode" set to "OFF (STEREO 1ch)?"

When you are using Dual Mono mode, be sure to set this to "ON (MONO 2ch)."

Also, Dual Mono mode playback is subject to a wide variety of conditions.

Check these carefully when using. For detailed information about the conditions, refer to "What Is Dual Mono Mode?" (p. 120).

The RS-232C port connection does not work as intended.

In the RS-232C settings, do you have the correct "Baud Rate" selected?

When you are using the RS-232C port, select a value that matches that of the equipment you are using.

In addition, check the device connections for the RS-232C connector.

→ "Baud Rate Setting" (p. 119)

The AR-LINK function does not work as intended

In the AR-LINK settings, is "AR-LINK Mode" set to "OFF?"

When using AR-LINK, set this to "MASTER" or "SLAVE" to match your usage conditions. In addition, check the device connections (OUT, IN) for the AR-LINK connector.

Check the AR-3000R to confirm that the AR-LINK device ID settings are correct.

Cannot make AR-LINK settings

Is "Dual Mono Mode" set to "On" (Dual Mono)?

When using AR-LINK, be sure to set Dual Mono Mode to Off.

About playback and recording of MIDI phrases

MIDI phrases cannot be recorded correctly

Some MIDI sequencers output MIDI sound generator setup messages (tone settings for each part, volume information, effects data, and so on) when a song is selected, and this may prevent MIDI messages from being recorded correctly when recording with the AR-3000R begins. In such instances, start recording with the AR-3000R first, then after this select and play back the song from the MIDI sequencer.

MIDI data cannot be recorded

Is "MIDI-IN" selected as the recording connector?

When you're recording MIDI data, choose "MIDI-IN" as the recording connector.

→ "Recording and Playing Back MIDI Data (MIDI Phrases)" – "Selecting the Recording Connector" (p. 83)

The displayed tempo for a MIDI phrase remains at 120.

The initial tempo of the AR-3000R is 120, so even if you record MIDI data having variable tempo to a MIDI phrase, tempo information is not recorded.

This means that the displayed tempo does not change during playback of MIDI phrases, but this is not a defect.

MIDI phrases are not played back

- Is "OUT" selected for MIDI output (MIDI OUT or THRU)?

OUT: This sends out MIDI information from the AR-3000R. Select this when you want to play back MIDI phrases or send Exclusive (SysEx) messages.

THRU: This takes MIDI information from MIDI IN and sends it out unchanged. MIDI information from the AR-3000R is not sent.

- Is the MIDI Receive channel set to "OFF?"

→ "MIDI Receive Channel (MIDI Channel) Settings" (p. 108)

About MIDI Control Playback

Phrases cannot be played back as intended in MIDI Control Playback

The assignments of phrases to the note numbers for Program Change 1 are made with settings on the unit. When a card is formatted, the assignments are Program Change 1, C-1: A0001 through G9: A0128. Also, you can assign 128 phrases of your choosing to Program Change 1, but please be aware that the phrase assignments to other program changes cannot be changed (see below).

- * *The 1,000 phrases on card A are assigned to Program Changes 21 through 30, and the phrase assignments cannot be changed.*
- * *The 1,000 phrases on card B are assigned to Program Changes 71 through 80, and the phrase assignments cannot be changed.*
- * *For compatibility with the AR-2000 format, 500 phrases on card A and 500 phrases on card B are assigned to Program Changes 2 through 6 and 7 through 11, and the phrase assignments cannot be changed.*
- * *By transmitting program change 128, you can then send a Note On message for a note number to interrupt a currently playing phrase.*

→ "Assignment of Phrases to Note Numbers (MIDI Note Map)" (p. 107)

Operation cannot be synchronized

- Is the MIDI output (MIDI OUT or THRU) selected correctly?
 OUT: This sends out MIDI information from the AR-3000R. Select this when you want to play back MIDI phrases or send Exclusive (SysEx) messages.
 THRU: This takes MIDI information from MIDI IN and sends it out unchanged.

MIDI information from the AR-3000R is not sent.

- Are the MTC "Sync Source" and "Sync Out" set correctly?
 Make the correct settings to match the circumstances, according to whether the AR-3000R is the master or the slave.
- If using MTC, are both devices set to the same MTC type?

→ "Selecting the MTC Type (30/29N/29D/25/24)" (p. 115)

- Check the AR-3000R to confirm that the MIDI device ID settings are correct.

→ "MIDI device ID settings" (p. 110).

Other Effects

No sound

- Reconfirm that the power to the AR-3000R or connected device is on.
- Reconfirm that the volume control on the AR-3000R or connected device is turned up.
- Reconfirm that there are no shorts in any connector cables.

The volume level of the instrument connected to LINE IN is too low.

Could you be using a connection cable that contains a resistor?

Use a connection cable that does not contain a resistor.

There is a scraping sound coming from the AR-3000R

In situations such as when control signals are input continuously, the movement of the internal relays may make a scraping sound, but this does not indicate any malfunction. To prevent overuse and failure of the relay, you may also switch to Repeat Playback in order to have the relay move only once.

→ "Repeat Play" (p. 57)

Sound input to the Mic jack is not output from the audio output jacks.

Sound input to the Mic jack is output from the audio output jacks only during recording or recording standby (REC-In: LINE+MIC-IN).

Please be aware that output at times other than recording or recording standby (REC-In: LINE+MIC-IN) is not possible.

Error messages

If there has been a mistake in operation, or if the AR-3000R is unable to continue processing as you directed, an error message will appear in the display. Note the message that appears, and take the appropriate action.

Regarding Cards

Display:	No card inserted. Insert a card.
Situation:	No card is inserted into either of the card slots.
Action:	Insert a card.
Display:	Incorrect format. Format card.
Situation:	The CF card is not formatted for use with the AR-3000R.
Action:	Format the CF card.
Display:	Card damaged. Format card.
Situation:	It is possible that the data in the CF card or the CF card itself has been damaged.
Action:	Format the CF card. If formatting is not possible, or if the same message appears after the card has been formatted, it may be that the CF card is malfunctioning. Use a different CF card.
Display:	Card full. Delete phrases.
Situation:	Data cannot be stored on the card because there is no free space.
Action:	Increase the amount of free space on the card, such as by deleting unneeded phrases.
Display:	Unsupported card. Change cards.
Situation:	This memory card cannot be used by the AR-3000R.
Action:	Use an AR-3000R CF card
Display:	Card protected. Write Failure.
Situation:	Card protect is set to ON, so data cannot be written to the card.
Action:	Set card protect to OFF.

Display:	Write-protected Cannot write card
Situation:	The card's write-protect switch is on.
Action:	Refer to the owner's manual for the CF card and switch off the write-protect switch.
Display:	Cannot change to AR-2000 card.
Situation:	Because the card is in AR-2000 format, setting changes and the like cannot be written to the card.
Action:	Convert the card to AR-3000 format, or use another card that is in AR-3000 format.
Display:	Battery low. Replace battery.
Situation:	The voltage of the card's battery has dropped.
Action:	Replace the battery for the card.

Playback Related

Display:	Cannot play back. Check phrase.
Situation:	Either the phrase data is damaged, or the AR-3000R is not able to handle the phrase.
Action:	Check the phrase for which the message was displayed.
Display:	No corresponding phrase.
Situation:	There is no phrase corresponding to the specified phrase.
Action:	Select a saved phrase or record a new phrase.

Recording Related

Display:	No signal from Digital In jack.
Situation:	There is no signal input from the Digital In jack.
Action:	Send signals from the digitally connected equipment.
Display:	Card access error. Change conditions
Situation:	Data was not written to or read from the card in time.
Action:	Change the RDAC-Grade, RDAC-Mode, or other recording conditions to reduce the amount of data.

Editing

- Display: Cannot set for selected phrase.
- Situation: A setting item does not correspond to the selected phrase.
- Action: Reselect a phrase for which the setting can be made, or record a new phrase.
-

MIDI Related

- Display: Buffer overflow
Modify trans.
- Situation: More MIDI data was received in a short time than the AR-3000R was able to process.
- Action: Change the way in which MIDI data is being transmitted.
-
- Display: MIDI Out at THRU
Nothing sent.
- Situation: Because MIDI output is set to THRU, MIDI data cannot be sent.
- Action: Set MIDI output to OUT.
-
- Display: No Active Sense
Recording stopped
- Situation: MIDI Active Sense was interrupted.
- Action: Check the status of the transmitter and the MIDI cable connections.
-
- Display: MIDI checksum error.
- Situation: Checksum error found in received MIDI data.
- Action: Check the transmission status and the MIDI data.
-

System Related

- Display: Unit overheated.
Let heat escape.
- Situation: The AR-3000R gets hot.
- Action: Ventilate well to avoid overheating, and keep the unit cool.
-

Regarding Card Conversion

* Refer to the Card Conversion List (p. 80).

- Display: Card conv. error
Not enough space
-
- Display: Unconvertible
record setting(s)
-
- Display: Playback point

- is set.
- Display: Unconvertible
pattern phrase(s)
-
- Display: Cannot convert,
song phrase(s).
-
- Display: Phr. after No.501
Cannot convert.
-
- Display: Phrase(s) stored
after No. 501.
-

Regarding AR-LINK

- Display: PhraseTypesDiffer
Can't sync play
- Situation: The RDAC-Grades, RDAC-Modes, or recording types of the phrases being played back on the master and on the slave are different.
- Action: Make sure the phrases being played back on the master and the slave have the same RDAC-Grade, RDAC-Mode, and recording type.
-
- Display: Phrase not found.
Can't sync playbk
- Situation: Because the phrase specified by AR-LINK does not exist, synchronized playback is not possible.
- Action: Specify a phrase that exists on the slave side.
-
- Display: More than one
AR-LINK master.
- Situation: No more than one AR-LINK master may exist on a single network.
- Action: Set to "Slave."
-
- Display: AR-LINK master.
Can't conn. to IN
- Situation: On the device set as the AR-LINK master, IN cannot be used.
- Action: Do not connect to AR-LINK IN on the device set as "Master."
-

Cards

Card-specific Audio Recording Time Chart

The following table shows recording times available for cards formatted for the AR-3000R.

- * Recording times listed are for mono recording. Recording times are halved when data is recorded in stereo.
- * These times are for when 1 phrase is recorded continuously, and are provided for your reference when recording. The recording time will depend on the combination of the grade settings of each phrase recorded in each memory card.

128 MB		RDAC-Mode				
		H-LINEAR	LINEAR	MODE3	MODE2*	MODE1
RDAC-Grade	S-HIGH	14:48	22:12	59:14	59:14	01:28:51
	HIGH	16:06	24:10	1:04:27	1:04:27	1:36:41
	STANDARD	22:12	33:19	1:28:51	1:28:51	2:13:17
	LONG1	32:13	48:20	2:08:54	2:08:54	3:13:22
	LONG2	44:25	1:06:38	2:57:43	2:57:43	4:26:35
	ANNOUNCE	1:28:51	2:13:17	5:55:27	5:55:27	8:53:11

512 MB		RDAC-Mode				
		H-LINEAR	LINEAR	MODE3	MODE2*	MODE1
RDAC-Grade	S-HIGH	59:16	1:28:55	3:57:07	3:57:07	5:55:40
	HIGH	1:04:29	1:36:44	4:17:59	4:17:59	6:26:58
	STANDARD	1:28:55	2:13:22	5:55:40	5:55:40	8:53:31
	LONG1	2:08:59	3:13:29	8:35:58	8:35:58	12:53:57
	LONG2	2:57:50	4:26:45	11:51:21	11:51:21	17:47:02
	ANNOUNCE	5:55:40	8:53:31	23:42:43	23:42:43	35:34:05

1 GB		RDAC-Mode				
		H-LINEAR	LINEAR	MODE3	MODE2*	MODE1
RDAC-Grade	S-HIGH	1:58:31	2:57:47	7:54:06	7:54:06	11:51:09
	HIGH	2:08:57	3:13:26	8:35:49	8:35:49	12:53:44
	STANDARD	2:57:47	4:26:41	11:51:09	11:51:09	17:46:44
	LONG1	4:17:54	6:26:52	17:11:39	17:11:39	25:47:28
	LONG2	5:55:34	8:53:22	23:42:18	23:42:18	35:33:28
	ANNOUNCE	11:51:09	17:46:44	47:24:37	47:24:37	71:06:56

- * Minimum recording times are listed only for MODE2. Depending on conditions, you may be able to attain recording times longer than listed here.

Settings When a Card Is Formatted

When a card is formatted, the values of various settings will be as shown below.

Recording settings

- REC-IN: LINE-IN
- RDAC-Grade: STANDARD
- RDAC-Mode: MODE3
- REC Type: STEREO
- Trig Level: OFF
- MIDI Time Base: 192

Phrase messages

- 1.1 Playback Volume: 100 %
- 1.2 Delay Time: 00s00f
- 1.3 Playback Point: MANUAL

Start: 00h00m00s00f0sf

End: The realtime of the phrase

- 1.4 Repeat Play: OFF
- 1.5 Loop Play: OFF
- 1.6 Fade
 - Fade In: OFF
 - Fade Out: OFF
- 1.7 Control Out: OFF
- 1.8 MIDI Tempo: 120
- 1.9 Phrase Name: AR-3000 1 (Card Name + Phrase No.)

Card editing

- 4.5 Card Protect: OFF
- 4.6 Card Name: AR-3000

Control input settings

- 5.1 Control Input Mode: DIRECT PLAY

- 5.2 Direct Play: NORMAL

- Phrase assignment

Port No.	Phrase
1	A0001 or B0001
2	A0002 or B0002
3	A0003 or B0003
4	A0004 or B0004
5	A0005 or B0005
6	A0006 or B0006
7	A0007 or B0007
8	A0008 or B0008
9	A0009 or B0009
10	A0010 or B0010
11	A0011 or B0011
12	A0012 or B0012
13	A0013 or B0013
14	A0014 or B0014
15	A0015 or B0015
16	A0016 or B0016

* A and B are determined by the slot in which the card is inserted when formatting.

- 5.3 Program Play

- Programs 1 played back in order

No.1: Phrase A0001 or B0001

↓

No.100: Phrase A0100 or B0100

- Programs 2 through 5 played back in order

No.1: Phrase ----

↓

No.100: Phrase ----

* A and B are determined by the slot in which the card is inserted when formatting.

- 5.4 Binary Play

- Level: ON
- Edge: OFF

- 5.5 Binary Rec

- Phrase Select: BINARY1

MIDI Settings

●6.1 MIDI Output (OUT or THRU):OUT

●6.2 MIDI Note Map

- Program Change 1

C-1: PhraseA0001 or B0001



G9: PhraseA0128 or B0128

* *A and B are determined by the slot in which the card is inserted when formatting.*

●6.3 MIDI Note Out: OFF

●6.4 MIDI Channel: OFF

●6.5 MIDI Note Trigger: TRIGGER

●6.6 MIDI Rx Message

- Note On Velocity: OFF
- Panpot: OFF
- Expression: OFF

●6.7 MIDI Device ID: 1

●6.8 MMC Mode: OFF

●6.9 MTC

- Sync Source: INTERNAL
- Sync Out: OFF
- MTC Type: 30
- MTC Error Level: 5

RS-232C Settings

●7.1 Baud Rate: 9600 bps

AR-LINK Settings

●8.1 AR-LINK Mode: OFF

System Settings

●9.1 Dual Mono Mode: OFF(STEREO 1ch)

●9.2 Line Thru

- Line Thru: ON
- Thru Volume: 0 %
- Fade Out: 0.5 s
- Fade In: 0.5 s

●9.3 Equalizer

- Switch: OFF
- Low Freq: 200 Hz
- Low Gain: 0 dB
- Hi Freq: 6 kHz
- Hi Gain: 0 dB
- Attenuation: 0dB

●9.4 Output Vol. Thru: OFF

●9.5 Busy Out

- Delay Time: ON
- Phrase Play: ON
- Repeat Int: ON

●9.6 Display Sleep: OFF

Recorded Phrase Data

When a piece of Phrase data recorded by the AR-3000R, the settings of data on the card will be as follows.

Phrase Settings

Playback Volume:100%

Delay Time: 00s00f

Playback Point:

- Start: 00h00m00s00f0sf
- End: The realtime of the phrase

Repeat Play: OFF

Loop Play: OFF

Fade:

- Fade In: OFF
- Fade Out: OFF

Control Out: OFF

MIDI Tempo: 120

Phrase Name:AR-3000 1

(AR-3000 + Phrase No.)

Terminals

Specifications of the Control Input/Output Terminals

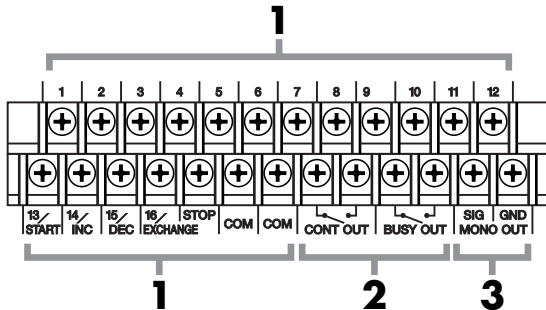

1. Control Input

Trigger Signal Format: On, Off (Open, Close), Pulse width: 20 msec or more

Contact capacity: DC 24 V, 0.1 A or more

Input: Photocoupler

Pins used for control input:

- Direct playback: 1–16, STOP, COM
 - Program playback: START, STOP, INC, DEC, EXCHANGE, COM
 - Binary playback: 1–10, 11, START, STOP, COM
 - Control-port recording : 1–10, 11, 13, 14, COM
- * Time from make-contact onset until playback starts is approximately 40 ms (typ.). However, please be aware that this may vary slightly depending on card type.
- * During binary playback, complete input specifying binary signals within 50 ms.
- * The two common (COM) connectors are connected internally, so you can achieve operation by making the connection to either one. In cases such as when you are connecting the control connectors of a number of AR units with a single make-contact point, connect one COM connector on each AR unit to each other. However, do not intermix this unit with other AR series devices. Doing so may result in unstable operation.

2. Control Output

Signal system: No-voltage make-contact

Contact capacity: DC 30 V, 5 A

Connectors used with control output:

- Busy Out: BUSY OUT
- Control Out: CONT OUT, make-contact time: 1 second

3. Audio Output Ports (MONO OUT)

MONO OUT is an audio output (mono, unbalanced) ports.

Rated output level: +4 dBu

Output Impedance: 500 ohm

Recommended Load Impedance: 10 k-ohms or greater

- * The control I/O connector cannot be used to switch the power to the AR unit on or off.
- * The output levels may change for stereo and mono audio phrases.

NOTE

When making connections to the ports, be careful not to lose the removed screws. Place the screws out of the reach of small children. If a screw is accidentally swallowed, immediately consult a physician.

RS-232C Connector Specifications

Transmission method: Start-Stop synchronous system (Asynchronous) Duplex data transmission

Baud rate: 4800 /9600/19200/38400 bps

Parity: none

Data length: 8 bit

Stop bit length: 1 bit

Code set: ASCII

- * The setting "38400" bps is for compatibility with legacy models (AR-3000/2000). However, it is a value for the communication speed that is not defined by the RS-232C standards.

Pin No.	Signal Name	Pin Connection
1	NC	
2	RXD	
3	TXD	
4	DTR	
5	GND	
6	DSR	
7	RTS	
8	CTS	
9	NC	

AR-3000R	Computer
1 : NC	1 : DCD
2 : RXD	2 : RXD
3 : TXD	3 : TXD
4 : DTR	4 : DTR
5 : GND	5 : GND
6 : DSR	6 : DSR
7 : RTS	7 : RTS
8 : CTS	8 : CTS
9 : NC	9 : RI

Terminals

In addition to the owner's manual, "RS-232C Reference Notes" are available for purchase as reference materials that cover RS-232C connector control. The PDF file can be downloaded free of charge from the following URL.

- The RS-232C Reference Notes cover the following topics:
 - Setup
 - Overviews, detailed descriptions, and lists of commands
 - Examples of usage algorithms

<http://www.rssamerica.com/>

AR-LINK Connectors Specifications



AR-LINK IN

AR-LINK OUT

Pin No.	Signal Name	Pin No.	Signal Name
1	CMD-	1	CMD+
2	CMD+	2	CMD-
3	TRG-	3	TRG+
4	GND	4	GND
5	TRG+	5	TRG-
6	CLK-	6	CLK+
7	NC	7	NC
8	CLK+	8	CLK-

Use an ARC-15 cable (sold separately) to connect to the AR-LINK connectors.

The cable specifications are as shown below.



mini DIN, 8-pin, male

mini DIN, 8-pin, male

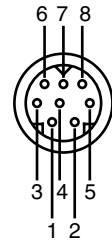
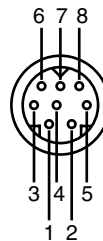

mini DIN, 8-pin, male

mini DIN, 8-pin, male

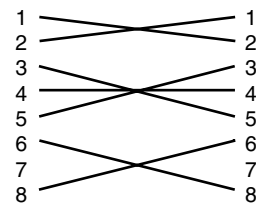

MIDI Implementation

Model: AR-3000R (Audio Recorder)

Date: May.5,2006

Version: 1.00

1. Receive data (Media Player Section)

■ Channel Voice Message

● Note Off

Status	Second	Third
8nH	kkH	vvH
9nH	kkH	00H

n = MIDI Channel No. : 0H - FH (ch.1 - ch.16)

kk = Note No. : 00H - 7FH (0 - 127)

vv = Velocity : 00H - 7FH (1 - 127)

* This stops playback of the phrase for the corresponding note number. (For more on the corresponding phrases, refer to the Note On parameter.)

* This is ignored when "Trigger" is selected for MIDI Trigger Mode.

* The Note Off Velocity value is ignored.

* Data is not received if the MIDI Receive channel setting is OFF. When set to 1-16, data is received only on the selected channel. When set to ALL, data is received on all channels.

● Note On

Status	Second	Third
9nH	kkH	vvH

n = MIDI Channel No. : 0H - FH (ch.1 - ch.16)

kk = Note No. : 00H - 7FH (0 - 127)

vv = Velocity : 01H - 7FH (1 - 127)

* This plays back the phrase for the corresponding note number.

* With Program Change 1 (normally turning the power on), all note numbers (128 numbers) are received. Corresponding phrase numbers may be selected freely.

* With Program Changes 21-30, only Note Numbers 00H-63H (0-99) are received. The phrase numbers correspond to 1-1000 on Card A. Phrase assignments cannot be changed.

* With Program Changes 71 through 80, only Note Numbers 00H through 63H (0 through 99) are received. The phrase numbers correspond to 1 through 1,000 on Card B. Phrase assignments cannot be changed.

* With Program Changes 2-6 and 7-11, only Note Numbers 00H-63H (0-99) are received. The phrase numbers correspond to 1-500 on Card A and 1-500 on Card B respectively. Phrase assignments (AR-2000 compatible) cannot be changed.

* With Program 128, playback of the phrase in progress is stopped, regardless of the note number.

* Data is not received if the MIDI Receive channel setting is "OFF." When set to 1-16, data is received only on the selected channel. When set to ALL, data is received on all channels.

* The Note On Velocity value changes the playback master volume.

* The Note On Velocity value is ignored in Dual Mono mode and MIDI playback.

* The Note On Velocity value is ignored when Note On Velocity is set to "Off."

● Control Change

○ Panpot (Controller number 10)

Status	Second	Third
BnH	OAH	vvH

n = MIDI Channel No. : 0H - FH (ch.1 - ch.16)

vv = Panpot : 00H - 7FH (0 - 127)

(0-64-127)

default value = 40H(64)

* This is adjustable in 127 steps, with 0 being full left, 64 center, and 127 full right.

* When Panpot is off, this is not received.

* When MIDI playback is conducted in Dual Mono mode, this is not received.

* Data is not received if the MIDI Receive channel setting is "OFF." When set to 1-16, data is received only on the selected channel. When set to ALL, data is received on all channels.

○ Expression (Controller number 11)

Status	Second	Third
BnH	0BH	vvH

n = MIDI Channel No. : 0H - FH (ch.1 - ch.16)

vv = Expression : 00H - 7FH (0 - 127)

default value = 7FH (127)

* This changes the volume level during playback of a phrase.

* When Expression is off, this is not received.

* When MIDI playback is conducted in Dual Mono mode, this is not received.

* Data is not received if the MIDI Receive channel setting is "OFF." When set to 1-16, data is received only on the selected channel. When set to ALL, data is received on all channels.

● Program Change

Status	Second
--------	--------

CnH ppH

n = MIDI Channel No. : 0H - FH (ch.1 - ch.16)

pp = Program number : 00H - 05H (prog.1 - prog.6)

: 06H - 0AH (prog.7 - prog.11)

: 14H - 1DH (prog.21 - prog.11)

: 46H - 4FHH (prog.71- prog.80)

: 7FH (prog.128)

* This switches the MIDI note map used for the phrase assignments.

* The change goes into effect with the first new Note On after the Program Change is received. This has no effect on phrases being played before the Program Change is received.

* Data is not received if the MIDI Receive channel setting is OFF. When set to 1-16, data is received only on the selected channel. When set to ALL, data is received on all channels.

■ System Common Message

● Quarter Frame Messages

* Data is received when Sync Source is set to "MTC." When the Quarter Frame message is received, operation proceeds with the start of the song synchronized to "00h00m00s00f00" with the "Delay Time" added.

* This acts upon the currently selected audio phrase.

* MIDI phrases and pattern phrases are ignored when Dual Mono mode is selected.

Status	Second
--------	--------

F1H mmH (= 0nnndddd)

nnn = Message type: 0 = Frame count LS nibble

1 = Frame count MS nibble

2 = Seconds count LS nibble

3 = Seconds count MS nibble

4 = Minutes count LS nibble

5 = Minutes count MS nibble

6 = Hours count LS nibble

7 = Hours count MS nibble

dddd = 4 bit nibble data : 0h - FH (0 - 15)

Bit Field is assigned as follows.

Frame Count xxxyyyyy

xxx Reserved (000)

yyyyy Frame No.(0-29)

Seconds Count xxxyyyyy

xx Reserved (00)

yyyyyy Seconds (0-59)

Minutes Count xxxyyyyy

xx Reserved (00)

yyyyyy Minutes (0-59)

Hours Count xyyzzzzz

x Reserved (0)

yy Time Code type

0 = 24 Frames / Sec

1 = 25 Frames / Sec

2 = 30 Frames / Sec (Drop Frame)

3 = 30 Frames / Sec (Non Drop Frame)

zzzzz Hours (0-23)

■ System Exclusive Message

Status	Data Bytes	Status
--------	------------	--------

F0H iiH, ddH,..., eeH F7H

FOH : System Exclusive Message status

iiH ID Number : an ID number (manufacturer ID) to indicate the manufacturer whose Exclusive message this is. Roland's manufacturer ID is 41H.

ID numbers 7EH and 7FH are extensions of the MIDI standard;

Universal Non-Real time Messages (7EH) and Universal Real time

Messages (7FH).

::

dd,..., ee = Data : 00H-7FH (0-127)

F7H :EOX (End of Exclusive Message)

The system Exclusive Messages received by the AR-3000R are; Data Set (DT1).

Regarding the Data Set (DT1), please refer to "exclusive Communication".

MIDI Implementation

● MIDI Time Code

○ Full Messages

- * Data is received when Sync Source is set to "MTC." When the Quarter Frame message is received, operation proceeds with the start of the song synchronized to "00h00m00s00f00" with the "Delay Time" added.
- * This acts upon the currently selected audio phrase.
- * MIDI phrases and pattern phrases are ignored when Dual Mono mode is selected.
- * Use the full message for specifying the tune (also for fast-forwarding and rewinding).

Status	Data Bytes	Status
F0H	7FH, dev, 01H, 01H, hrH, mnH, scH, frH	F7H

Byte	Description
F0H	Status of Exclusive Message
7FH	Universal System Exclusive Message Real time Header
dev	device ID (or 7FH)
01H	sub-ID#1 (MIDI Time Cord)
01H	sub-ID#1 (Full Messages)
hrH	Hours Count xyyzzzzz x Reserved (0) yy Time Code type 0 = 24 Frames / Sec 1 = 25 Frames / Sec 2 = 30 Frames / Sec (Drop Frame) 3 = 30 Frames / Sec (Non Drop Frame) zzzzz Hours (0-23)
mnH	Minutes Count xyyyyyyy xx Reserved (00) yyyyyy Minutes (0-59)
scH	Seconds Count xyyyyyyy xx Reserved (00) yyyyyy Seconds (0-59)
frH	Frame Count xyyyyyyy xxx Reserved (000) yyyyy Frame No.(0-29)
F7H	EOX (End of Exclusive)

● MIDI Machine Control (MMC)

- * This is Received when the MMC mode is set to "SLAVE."
- * This acts upon the currently selected phrase.

○ STOP (MCS)

Status	Data Bytes	Status
F0H	7FH, dev, 06H, 01H	F7H
Byte	Description	
F0H	Status of Exclusive Message	
7FH	Universal System Exclusive Message Real time Header	
dev	device ID (or 7FH)	
06H	MMC Command Message	
01H	STOP (MCS)	
F7H	EOX (End of Exclusive Message)	

- * Playback is stopped immediately when this command is received if the device ID matches, or if 7FH is received.

○ PLAY (MCS)

Status	Data Bytes	Status
F0H	7FH, dev, 06H, 02H	F7H
Byte	Description	
F0H	Status of Exclusive Message	
7FH	Universal System Exclusive Message Real time Header	
dev	device ID (or 7FH)	
06H	MMC Command Message	
02H	PLAY (MCS)	
F7H	EOX (End of Exclusive Message)	

- * Playback is started immediately when this command is received if the device ID matches, or if 7FH is received.

○ DEFERRED PLAY (MCS)

Status	Data Bytes	Status
F0H	7FH, dev, 06H, 03H	F7H
Byte	Description	
F0H	Status of Exclusive Message	
7FH	Universal System Exclusive Message Real time Header	
dev	device ID (or 7FH)	
06H	MMC Command Message	
03H	DEFERRED PLAY (MCS)	
F7H	EOX (End of Exclusive Message)	

- * Playback is started immediately when this command is received if the device ID matches, or if 7FH is received.

○ RECORD STROBE (MCS)

Status	Data Bytes	Status
F0H	7FH, dev, 06H, 06H	F7H
Byte	Description	
F0H	Status of Exclusive Message	
7FH	Universal System Exclusive Message Real time Header	
dev	device ID (or 7FH)	
06H	MMC Command Message	
06H	RECORD STROBE (MCS)	
F7H	EOX (End of Exclusive Message)	

- * Recording of the phrase begins when this command is received if the device ID matches, or if 7FH is received.

- * If MIDI signal recording is in effect, this command is ignored (MIDI cannot be recorded with MMC).

○ RECORD EXIT (MCS)

Status	Data Bytes	Status
F0H	7FH, dev, 06H, 07H	F7H
Byte	Description	
F0H	Status of Exclusive Message	
7FH	Universal System Exclusive Message Real time Header	
dev	device ID (or 7FH)	
06H	MMC Command Message	
06H	RECORD STROBE (MCS)	
F7H	EOX (End of Exclusive Message)	

- * Recording is stopped immediately when this command is received if the device ID matches, or if 7FH is received.

- * If MIDI signal recording is in effect, this command is ignored (MIDI cannot be recorded with MMC).

○ LOCATE (MCP)

Format 2 - LOCATE [TARGET]

Status	Data Bytes	Status
F0H	7FH, dev, 06H, 44H, 06H, 01H, hrH, mnH, scH, frH, ffH	F7H

Byte	Description
F0H	Status of Exclusive Message
7FH	Universal System Exclusive Message Realtime Header
dev	device ID (or 7FH)
06H	MMC Command Message
44H	LOCATE(MCP)
06H	Number of Bytes
01H	[TARGET] sub command
hrH	Standard time with Sub Frame
mnH	
scH	
frH	
ffH	
F7H	EOX (End of Exclusive Message)

- * If the device ID matches, or if 7FH is received, then when this command is received, the location of the time code specified in the command data is located.

- * MIDI phrases and pattern phrases are ignored when Dual Mono mode is selected.

2. Transmitted data (Media Player Section)

2.1 Transmitted messages while a phrase is being played back

The stored MIDI message are transmitted When the MIDI phrase will playback after OUT is set in the MIDI OUT.

In this case, AR-3000R is not transmitted MIDI messages which are received.

2.2 Transmitted message which are received.

When THRU is set in the MIDI OUT, AR-3000R transmits message which are received.

2.3 Transmitted message which are produced.

When OUT is set in the MIDI OUT, AR-3000R transmits the following produced messages.

■ Channel Voice Message

● Note Off

Status	Second	Third
8nH	kkH	40H
n = MIDI Channel No.	: 0H -- FH (ch.1--ch.16)	
kk = Note No.	: 00H--7FH (0--127)	

* After the MIDI Phrase is stopped, AR-3000R produces Note off message for received notes remains on.

* When Note On is sent at the start of an audio performance, the same note number as that of the Note On is transmitted. For more information about sending notes, refer to the Note On section below.

● Note ON

Status	Second	Third
9nH	kkH	7FH
n = MIDI Channel No.	: 0H--FH (ch.1--ch.16)	
kk = Note No.	: 00H--7FH (0--127)	

* At the start of the audio phrase performance, the note number defined in the MIDI note map is sent. In this instance, if multiple note numbers are selected in the phrase, only the lowest note number is transmitted.

* There is no transmission when the Note Send setting is set to "OFF".

* Data is not output if the MIDI Receive channel setting is "OFF." When set to 1-16, data is transmitted only on the selected channel. When set to ALL, data is transmitted on Channel 1.

* There is no transmission during playback of MIDI phrases.

● Control Change

○ Hold1 OFF

Status	Second	Third
BnH	40H	00H
n = MIDI Channel No.	: 0H--FH (ch.1--ch.16)	

* *After the MIDI Phrase is stopped, AR-3000R produces Note off message for received notes remains on.

■ Channel Mode Message

● All Note Off (Controller No. 1 2 3)

Status	Second	Third
BnH	7BH	00H
n = MIDI channel No.	: 0H--FH (ch.1--ch.16)	

* Transmitted message while a phrase is being played back.

2.4 Recognized message for sync

■ System Realtime Message

● Timing Clock

status

F8H

* Transmitted message while a phrase is being played back.

● Start

status

FAH

● Stop

status

FCH

■ System Common Message

● Quarter Frame

* This is transmitted when Sync Out is set to "MTC." The time count transmitted is the time with the start of the song set to "00h00m00s00f00" with the "Delay Time" added.

* MIDI phrases and pattern phrases are not transmitted when Dual Mono mode is selected.

status second

F1H mmH (= 0nnndddd)

Regarding the Quarter Frame, please refer to "Receive data (Media Player Section) ~Quarter Frame~".

■ System Exclusive Message

● MIDI Time Cord

○ Full Message

* This is transmitted when Sync Out is set to "MTC" and the location of the phrase is moved. The time count transmitted is the time with the start of the song set to "00h00m00s00f00" and the "Delay Time" added.

* MIDI phrases and pattern phrases are not transmitted when Dual Mono mode is selected.

* Device ID = 7FH

Status	Data Bytes	Status
F0H	7FH, dev, 01H, 01H	F7H
	hrH, mnH, scH, frH	

Regarding the MIDI Time Cord, please refer to "Receive data (Media Player Section) ~MIDI Time Cord~".

● MIDI Machine Control (MMC)

* Data is transmitted when MMC mode is set to "MASTER."

○ STOP (MCS)

Status	Data Bytes	Status
F0H	7FH, dev, 06H, 01H	F7H
Byte	Description	
F0H	Status of System Exclusive Message	
7FH	Universal System Exclusive Message Real time Header	
dev	device ID (7FH)	
06H	MMC Command Message	
01H	STOP (MCS)	
F7H	EOX (End of System Exclusive Message)	

* When playing of a phrase is stopped, a STOP message is transmitted.

○ DEFERRED PLAY (MCS)

Status	Data Bytes	Status
F0H	7FH, dev, 06H, 01H	F7H
Byte	Description	
F0H	Status of System Exclusive Message	
7FH	Universal System Exclusive Message Real time Header	
dev	device ID (7FH)	
06H	MMC Command Message	
03H	DEFERRED PLAY (MCS)	
F7H	EOX (End of System Exclusive Message)	

* When "START" is pressed, a DEFERRED PALY message is transmitted.

○ RECORD STROBE (MCS)

Status	Data Bytes	Status
F0H	7FH, dev, 06H, 07H	F7H
Byte	Description	
F0H	Status of System Exclusive Message	
7FH	Universal System Exclusive Message Real time Header	
7FH	device ID (7FH)	
06H	MMC Command Message	
06H	RECORD STROBE (MCS)	
F7H	EOX (End of System Exclusive Message)	

* When recording of a phrase begins, a RECORD STROBE message is transmitted.

○ RECORD EXIT (MCS)

Status	Data Bytes	Status
F0H	7FH, dev, 06H, 07H	F7H
Byte	Description	
F0H	Status of System Exclusive Message	
7FH	Universal System Exclusive Message Real time Header	
dev	device ID (7FH)	
06H	MMC Command Message	
07H	RECORD EXIT	
F7H	EOX (End of System Exclusive Message)	

* When recording of a phrase is stopped, a RECORD EXIT message is transmitted

MIDI Implementation

○ LOCATE (MCP)

format2 - LOCATE [TARGET]

Status	Data Bytes	Status
F0H	7FH, dev, 06H, 44H, 06H	F7H
	01H, hrH, mnH, scH, frH, ffH	

Byte	Description
F0H	Status of System Exclusive Message
7FH	Universal System Exclusive Message Real time Header
dev	device ID (7FH)
06H	MMC Command Message
44H	LOCATE (MCP)
06H	Number of byte
01H	[TARGET] sub command
hrH	Standard time with Sub Frame
mnH	
scH	
frH	
ffH	
F7H	EOX (End of System Exclusive Message)

* When the location is moved, a LOCATE message is transmitted.

* MIDI phrases and pattern phrases are not transmitted when Dual Mono mode is selected.

3. Receive data (MIDI Recorder Section)

3.1 Message memorized during recording

■ Channel Voice Message

● Note Off

Status	Second	Third
8nH	kkH	vvH
9nH	kkH	00H

n = MIDI Channel No. : 0H - FH (ch.1 - ch.16)
 kk = Note No. : 00H - 7FH (0 - 127)
 vv = Velocity : 00H - 7FH (1 - 127)

● Note On

Status	Second	Third
9nH	kkH	vvH

n = MIDI Channel No. : 0H - FH (ch.1 - ch.16)
 kk = Note No. : 00H - 7FH (0 - 127)
 vv = Velocity : 01H - 7FH (1 - 127)

● Polyphonic Key Pressure

Status	Second	Third
AnH	kkH	vvH

n = MIDI Channel No. : 0H - FH (ch.1 - ch.16)
 kk = Note No. : 00H - 7FH (0 - 127)
 vv = value : 00H - 7FH (0 - 127)

● Control Change

status	Second	Third
BnH	kkH	vvH

n = MIDI Channel No. : 0H - FH (ch.1 - ch.16)
 kk = Controller No. : 00H - 7FH (0 - 127)
 vv = value : 00H - 7FH (0 - 127)

● Program Change

Status	Second	Third
CnH	ppH	vvH

n = MIDI Channel No. : 0H - FH (ch.1 - ch.16)
 pp = Program No. : 00H - 7FH (0 - 127)

● Channel Pressure

Status	Second
BnH	kkH

n = MIDI Channel No. : 0H - FH (ch.1 - ch.16)
 vv = value : 00H - 7FH (0 - 127)

● Pitch Bend Change

Status	Second
EnH	llH

n = MIDI Channel No. : 0H - FH (ch.1 - ch.16)

■ Channel Mode Message

● All Sound Off

Status	Second	Third
BnH	78H	00H

n = MIDI channel No. : 0H - FH (ch.1 --ch 16)

● Reset All Controller

Status	Second	Third
BnH	78H	00H

n = MIDI channel No. : 0H - FH (ch.1 --ch 16)

● Local On / Off

Status	Second	Third
BnH	7AH	vvH

n = MIDI channel No. : 0H - FH (ch.1 --ch 16)
 vv = value : 00H, 7FH (OFF, ON)

● MONO

Status	Second	Third
BnH	7EH	mmH

n = MIDI channel No. : 0H - FH (ch.1 --ch 16)
 mm = mono number : 00H - 10H (0 - 16)

* The same processing will be carried out as when All Notes Off is received.

● POLY

Status	Second	Third
BnH	7EH	00H

n = MIDI channel No. : 0H - FH (ch.1 --ch 16)
 mm = mono number : 00H - FH (0 - 16)

* The same processing will be carried out as when All Notes Off is received.

■ System Exclusive Message

Status	Data Bytes	Status
F0H	iiH, ddH,..., eeH	F7H

FOH : System Exclusive Message status

iiH ID Number : an ID number (manufacturer ID) to indicate the manufacturer whose Exclusive message this is. Roland's manufacturer ID is 41H. ID numbers 7EH and 7FH are extensions of the MIDI standard; Universal Non-real-time Messages (7EH) and Universal Real time Messages (7FH).

dd,..., ee = Data : 00H-7FH (0-127)

F7H : EOX (End of Exclusive Message)

3.2 Message not memorized during recording

■ Channel Mode Message

● All Note Off

Status	Second	Third
BnH	78H	00H

n = MIDI channel No. : 0H - FH (ch.1 --ch 16)

* Note Off is generated for any note not set to OFF, and this note off is stored.

● OMNI OFF

Status	Second	Third
BnH	78H	00H

n = MIDI channel No. : 0H - FH (ch.1 --ch 16)

* The same processing will be carried out as when All Notes Off is received.

● OMNI ON

Status	Second	Third
BnH	7AH	vvH

n = MIDI channel No. : 0H - FH (ch.1 --ch 16)
 vv = value : 00H, 7FH (OFF, ON)

* The same processing will be carried out as when All Notes Off is received.

3.3 Recognized message for remote control

■ System Real time Message

● Start

status
F8H

* Not received when recording mode is not "Standby".

● Continue

status
FBH

- * Not received when recording mode is not "Standby".
- * The same processing will be carried out as when Start is received.

● **Stop**

status
FCH

- * Not received when recording mode is not "record".

3.4 Messages received for detecting trouble in MIDI connection.

■ System Realtime message

● **Active Sensing**

Status
FEH

- * When Active Sensing is received, the unit will begin monitoring the intervals of all further messages. While monitoring, if the interval between messages exceeds 400 ms, the same processing will be carried out as when All Sounds Off, All Notes Off and Reset All Controllers are received, and message interval monitoring will be halted.

4. Transmit data (MIDI Recorder Section)

When AR-3000R is in MIDI Recorder mode, MIDI Messages is not transmitted.

5. Exclusive Communication

Exclusive message model IDs that can be used on the AR-3000R are OOH, 00H, and 37H (AR-3000R). The Device Id can be set to 00H to 1FH.

Only received when AR-3000R is in Media Player Section.

● **Data Set 1 DT1 (12H)**

Byte	Description
F0H	Status of System Exclusive Message
41H	Universal System Exclusive Message Real time Header
dev	device ID (dev : 00H-1FH)
mdl	Model ID (mdl : 00H, 37H) AR-3000R
12H	Command ID (DT1)
aaH	address MSB
:	:
ccH	Address LSB
ddH	Data
:	:
kkH	Data
sum	Check Sum
F7H	EOX (End of System Exclusive Message)

5.1 Parameter Address Map

This map indicates address,size, data (range), Parameter, Description,and default Value of parameters which can be transferred using "Data Set1(DT1)."

All the numbers of address, size, Data, and default Value are indicated in 7-bit Hexadecimal-form.
(AR-3000R Model ID=00H,37H)

■ Address Block Map

An outlined address map of the Exclusive Communication is as follows;

○ **Exclusive Address Table for recording setting**

Address(H)	SIZE(H)	DATA(H)	Parameter	Description
00 00 10	00 00 08	00 - 07	Phrase Number	upper 4bits
		11#	Phrase Number	lower 7bits
		12#	Grade	0:ANNOUNCE 1:LONG2 2:LONG1 3:STANDARD 4:HIG 5:S-HIGH
		13#	R-DAC mode	0:Linear 1:Mode1 2:Mode2 3:Mode3 4:H-LINEAR
		14#	REC type	0:MONO 1:STEREO
		15#	REC Trigger Level	0:OFF 1:LOW 2:MID 3:HIG
		16#	REC Source	0:LINE-IN 1:LINE+MIC-IN 2:DIGITAL-IN 3:MIDI-IN
		17#	TimeBase	0:192 1:240

Phrase number	DATA(H)
A0001-A1000	00 00 - 07 67
B0001-B1000	07 68 - 0H 4F

- * Only received packet data.

- * When reception of this packet is completed, the AR-3000R goes into REC PAUSE mode. However, if the phrase already exists, the AR-3000R ignores this SysEx message.

(AR-2000 compatible)

Address(H)	SIZE(H)	DATA(H)	Parameter	Description
00 00 00	00 00 08	00 - 07	Phrase Number	upper 3bits
		01#	Phrase Number	lower 7bits
		02#	Grade	0:ANNOUNCE 1:LONG2 2:LONG1 3:STANDARD 4:HIG
		03#	R-DAC mode	0:Linear 1:Mode1 2:Mode2
		04#	REC type	0:MONO 1:STEREO
		05#	REC Trigger Level	0:OFF 1:LOW 2:MID 3:HIG
		06#	REC Source	0:ANALOG-IN (MIDI REC OFF) 1:MIDI-IN (MIDI REC ON)
		07#	TimeBase	0:192 1:240

Phrase number	DATA(H)
A0001 - A0500	00 00 - 03 73
B0001 - B0500	03 74 - 07 67

- * Only received packet data.

- * When reception of this packet is completed, the AR-3000R goes into REC PAUSE mode. However, if the phrase already exists, the AR-3000R ignores this SysEx message.

- * ANALOG-IN for REC Source is set to LINE-IN on the AR-3000R.

MIDI Implementation

○ Exclusive Address Table Recording setting (Replacement Recording)

Address(H)	SIZE(H)	DATA(H)	Parameter	Description
00 01 10	00 00 08	00 - 07	Phrase Number	upper 4bits
11#		00 - 7f	Phrase Number	lower 7bits
12#		00 - 05	Grade	0:ANNOUNCE
				1:LONG2
				2:LONG1
				3:STANDARD
				4:HIGH
				5:S-HIGH
13#	00 - 02		R-DAC mode	0:Linear
				1:Mode1
				2:Mode2
				3:Mode3
				4:H-Linear
14#	00 - 01		REC type	0:MONO
				1:STEREO
15#	00 - 03		REC Trigger Level	0:OFF
				1:LOW
				2:MID
				3:HIGH
16#	00 - 03		REC Source	0:LINE-IN
				1:LINE+MIC-IN
				2:DIGITAL-IN
				3:MIDI-IN
17#	00 - 01		TimeBase	0:192
				1:240

Phrase number	DATA(H)
A0001 - A1000	00 00 - 07 67
B0001 - B1000	07 68 - 0F 4F

- * Only received packet data.
- * When reception of this packet is completed, the AR-3000R goes into REC PAUSE mode. However, if a phrase has already been saved, the AR-3000R deletes that phrase and goes into REC PAUSE mode.

(AR-2000 compatible)

Address(H)	SIZE(H)	DATA(H)	Parameter	Description
00 01 00	00 00 08	00 - 07	Phrase Number	upper 3bits
01#		00 - 7f	Phrase Number	lower 7bits
02#		00 - 04	Grade	0:ANNOUNCE
				1:LONG2
				2:LONG1
				3:STANDARD
				4:HIGH
03#	00 - 02		R-DAC mode	0:Linear
				1:Mode1
				2:Mode2
04#	00 - 01		REC type	0:MONO
				1:STEREO
05#	00 - 03		REC Trigger Level	0:OFF
				1:LOW
				2:MID
				3:HIGH
06#	00 - 01		REC Source	0:ANALOG-IN
				(MIDI REC OFF)
				1:MIDI-IN
				(MIDI REC ON)
07#	00 - 01		TimeBase	0:192
				1:240

Phrase number	DATA(H)
A0001 - A0500	00 00 - 03 73
B0001 - B0500	03 74 - 07 67

- * Only received packet data.
- * When reception of this packet is completed, the AR-3000R goes into REC PAUSE mode. However, if a phrase has already been saved, the AR-3000R deletes that phrase and goes into REC PAUSE mode.
- * ANALOG-IN for REC Source is set to LINE-IN on the AR-3000R.

○ Exclusive Address Table Phrase Select

Address(H)	SIZE(H)	DATA(H)	Parameter	Description
01 00 10	00 00 02	00 - 07	Phrase Number	upper 4bits
11#		00 - 7f	Phrase Number	lower 7bits

Phrase number	DATA(H)
A0001 - A1000	00 00 - 07 67
B0001 - B1000	07 68 - 0F 4F

- * Only received packet data.
- * When reception of this packet is completed, the AR-3000R changes to the current (currently displayed) phrase number.

(AR-100/2000 compatible)

Address(H)	SIZE(H)	DATA(H)	Parameter	Description
01 00 00	00 00 02	00 - 07	Phrase Number	upper 3bits
01#		00 - 7f	Phrase Number	lower 7bits

Phrase number	DATA(H)
A0001 - A0500	00 00 - 03 73
B0001 - B0500	03 74 - 07 67

- * Only received packet data.
- * When reception of this packet is completed, the AR-3000R changes to the current (currently displayed) phrase number.

○ Exclusive Address Table Recording Settings (Replacement Recording)

Address(H)	SIZE(H)	DATA(H)	Parameter	Description
01 00 10	00 00 03	00 - 07	Phrase Number	upper 4bits
11#		00 - 7f	Phrase Number	lower 7bits
12#		00 - 02	REC Source	0:ANALOG-IN
				1:LINE+MIC-IN
				2:DIGITAL-IN
				3:MIDI-IN

Phrase number	DATA(H)
A0001 - A1000	00 00 - 07 67
B0001 - B1000	07 68 - 0F 4F

- * Only received packet data.
- * When reception of this packet is completed, the AR-3000R goes into REC PAUSE mode. However, if a phrase has already been saved, the AR-3000R deletes that phrase and goes into REC PAUSE mode.

(AR-100/2000 compatible)

Address(H)	SIZE(H)	DATA(H)	Parameter	Description
01 00 00	00 00 03	00 - 07	Phrase Number	upper 3bits
01#		00 - 7f	Phrase Number	lower 7bits
02#		00 - 01	REC Source	0:ANALOG-IN
				(MIDI REC OFF)
				1:MIDI-IN
				(MIDI REC ON)

Phrase number	DATA(H)
A0001 - A0500	00 00 - 03 73
B0001 - B0500	03 74 - 07 67

- * Only received packet data.
- * When reception of this packet is completed, the AR-3000R goes into REC PAUSE mode. However, if a phrase has already been saved, the AR-3000R deletes that phrase and goes into REC PAUSE mode.
- * ANALOG-IN for REC Source is set to LINE-IN on the AR-3000R.

MIDI Implementation Chart

Media Player Section

Function ...	Transmitted	Recognized	Remarks
Basic Channel Default Changed	All channels x	*1 x 1-16	Memorized
Mode Default Message Altered	x x *****	x x	*2 *2
Note Number : True Voice	0-127 *****	x x	*2
Velocity Note ON Note OFF	o o	*1 *1 x x	
After Touch Key's Ch's	o o	*1 *1 x x	
Pitch Bend	o	*1 x	
Control Change 10 11 0-119	o o o	*1 *1 *1 x x x	*2 *2 Panpot Expression Messages other than the above
Program Change : True #	o *****	*1 x 1-11, 21-30, 71-80	*2
System Exclusive	o	*1 o	
System Common : Quarter Frame : Song Pos : Song Sel : Tune	x x x x	*3 x x x x	*4
System Real Time : Clock : Commands	o o	*1 x x	
Aux Messages : All Sounds OFF : Reset All Controllers : Local ON/OFF : All Notes OFF : Active Sensing : System Reset	o o x o x x	*1 *1 *1 x x x	
Notes	*1 Transmitted only during MIDI phrase playback *2 o x is selectable. *3 Transmitted when Sync Out is at MTC. *4 Received when Sync Source is at MTC.		

Mode 1 : OMNI ON, POLY

Mode 2 : OMNI ON, MONO

o : Yes

Mode 3 : OMNI OFF, POLY

Mode 4 : OMNI OFF, MONO

x : No

MIDI Implementation Chart

MIDI Recorder Section

Function ...	Transmitted	Recognized	Remarks
Basic Channel Default Changed	x x	all channels x	Not Basic Channel
Mode Default Message Altered	x x *****	x x	
Note Number : True Voice	x *****	0-127 0-127	
Velocity Note ON Note OFF	x x	o o	
After Touch Key's Ch's	x x	o o	
Pitch Bend	x	o	
Control Change 0-119	x	o	
Program Change : True #	x *****	o 0-127	
System Exclusive	x	o	
System Common : Quarter Frame : Song Pos : Song Sel : Tune	x x x x	x x x x	
System Real Time : Clock : Commands	x x	*1 x o	
Aux Messages : All Sounds OFF : Reset All Controllers : Local ON/OFF : All Notes OFF : Active Sensing : System Reset	x x x x x x	o o x o (123-127) *1 o x	
Notes	Mode messages (123-127) are stored/transmitted after All Note Off processing is performed.		

Mode 1 : OMNI ON, POLY
Mode 3 : OMNI OFF, POLY

Mode 2 : OMNI ON, MONO
Mode 4 : OMNI OFF, MONO

o : Yes
x : No

Specification

Recording Format

RDAC (Roland Digital Audio Coding)

RDAC-GRADE (Sampling rate)

S-HIGH:	48kHz
HIGH:	44.1kHz
STANDARD:	32kHz
LONG1:	22.05kHz
LONG2:	16kHz
ANNOUNCE:	8kHz

Playback rate Area

S-HIGH:	20Hz–22kHz
HIGH:	20Hz–20kHz
STANDARD:	20Hz–15kHz
LONG1:	20Hz–10kHz
LONG2:	20Hz–7.5kHz
ANNOUNCE:	20Hz–3.7kHz

RDAC-Mode (Signal processing method)

H-Linear:	24-bit PCM recording
Linear:	16-bit PCM recording
Mode 3:	2.5 times extended Recording time than Linear.
Mode 2:	2.5 times more extended Recording time than Linear.
Mode 1:	4 times more extended Recording time than Linear.

Recording media

Memory card (CF card)

* In order to recording/playback of audio signal and MIDI data, you will need to purchase one of the CF cards.

Compact Flash card Slot

2 Slot (TYPE1)

Phrase types

Audio phrases (stereo/mono)

MIDI phrases

Number of phrases

Maximum 1000 Phrases (when 1 CF card is used)

Maximum 2000 phrases (when 2 CF cards are use)

Playback method

Manual playback

Direct playback: 16 phrases, 4 modes(Normal, First-In, Last-In, Sequence)

Program playback: 100 phrases, 5 program

Binary playback: 2000 phrases

Computer-controlled playback: 2000 phrases

100 phrases(continuous play)

MIDI playback: 2000 phrases

AR-LINK playback: 2000 phrases

Equalizer

High : -12dB – +12dB (3/6kHz, Shelving Type)

Low : -12dB – +12dB (200/400Hz, Shelving Type)

Residual Noise Level (Input Short, front sense: middle, rear sense: middle, IHF-A, typ.)

- 80 dBu

S/N Ratio

BALANCED OUTPUT : 90 dB (IHF-A, Typ)

RS-232C

Transmission method: Start-Stop synchronous system (Asynchronous)Duplex data transmission

Baud rate: 4800 /9600/19200/38400 bps

Parity: none

Data length: 8 bits

Stop bit length: 1 bit

Code set: ASCII

* The setting "38400" bps is for compatibility with legacy models (AR-3000/ 2000). However, it is a value for the communication speed that is not defined by the RS-232C standards.

Display

160 x 48 dots Graphic LCD (Backlight)

Specification

Controllers

MIC INPUT Volume Knob
LINE INPUT Volume Knob
Card Eject Button
PLAY Button
STOP Button
PAUSE, BACK Button
EZ SETUP Button
MODE Button
ENTER Button
SELECT Dial (Doubles As SELECT Button)
OUTPUT Volume Knob
POWER Switch

Indicators

CARD ACCESS Indicator
PLAY Indicator
PAUSE Indicator
EZ SETUP Indicator
MODE Indicator

Connectors

MIC IN Jack (1/4 inch TRS phone type)
LINE IN Jacks (MONO/L,R, RCA phono type)
DIGITAL IN Connector (RCA phono type, Coaxial type, S/P DIF, EIAJ CP-1201-compliant)
Control I/O Terminal (25 pin Terminal Block with M3 screws)
MIDI Connectors (OUT/THRU, IN, 5-pin DIN type)
RS-232C Connector (9 pin D-sub type)
AR-LINK Connectors (OUT, IN, 8-pin mini DIN type)
Audio Output Jacks (1/4 inch TRS phone type, balanced)
Head Phone Jack (Stereo 1/4 inch phone type)

Power Supply

AC 117 V, AC 230 V or AC 240 V (50/60Hz)

Power Consumption

11 W (117 V)
12 W (230, 240 V)

Dimensions

482 (W) x 231.4 (D) x 44 (H) mm
19 (W) x 9-1/8 (D) x 1-3/4 (H) inches
(EIA-1U rack mount type)

Weight

2.7 kg/6 lbs

Operating Free-air Temperature Range

0–40 degrees Celsius
32–104 degrees Fahrenheit

Operating Free-air Humidity Range

0–80 % (non-condensing)

Accessories

Power Cord
Rubber Foot x 4
Card Protector x 2 (With 4 Screws)
Owner's Manual

Options

Network Board (AR-NT1R)
AR-LINK Cable (ARC-15)

* $0\text{ dBu}=0.775V_{\text{rms}}$

* *In the interest of product improvement, the specifications and/or appearance of this unit are subject to change without prior notice.*

* *In addition to the owner's manual, the separate publication "RS-232C Reference Notes" is also available for those needing detailed documentation regarding RS-232C connector control. Please download the PDF-file (free of charge) from the following URL.*

- The RS-232C Reference Notes cover the following topics:
 - Setup
 - Overviews, detailed descriptions, and lists of commands
 - Examples of usage algorithms

<http://www.rssamerica.com/>

Input/Output Standard

Input Standard (Volume: center)

Input	Input Sense	Rated Input Level	Non Clip Max Input Level	Input Impedance	Recommended Source Impedance
MIC Input Jack	-55 dBu	-40 dBu	-42 dBu	2 kohms	1 kohms or less
Line Input Jack	-15 dBu	0 dBu	+2 dBu	20 kohms (stereo)	2 kohms or less

Output Standard (Volume: center)

Output	Rated Output Level	Non Clip Max Output Level	Output Impedance	Recommended Load Impedance
Audio output Jack	+4 dBu	+6 dBu	500 ohms	600 ohms or more
Headphone Jack	-----	90 mW+90 mW *1	100 ohms	30 ohms or more

* 0 dBu = 0.775 Vrms

*1: 100 ohms with both channels loaded

Dimensions

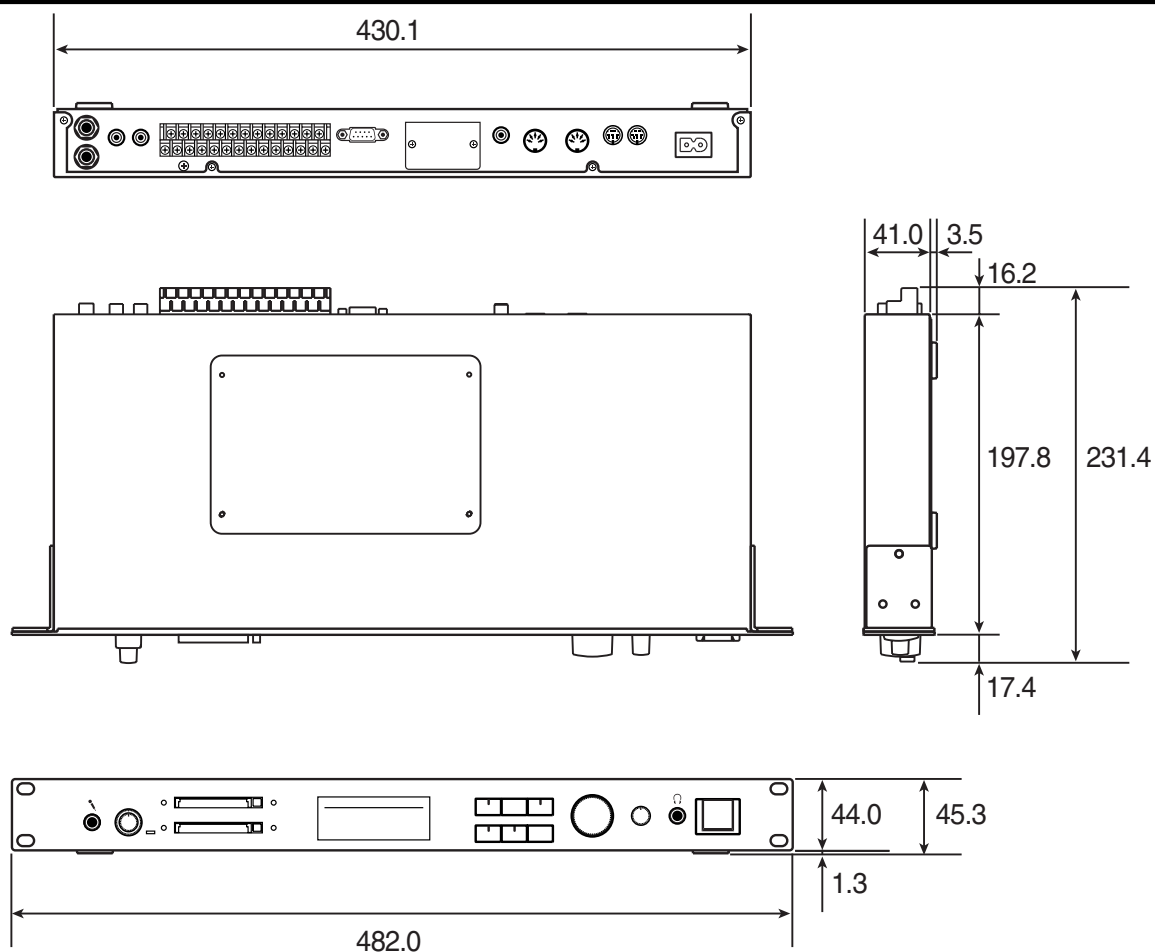

* Dimensions are with card inserted and rubber feet (included) attached.

* The power cord is not included.

Index

A

AR-LINK	22, 123
AR-LINK Connectors	138
Attenuation	126

B

Baud Rate	119
Binary Playback	92
Binary Recording	98
Busy Out	102

C

Card Audio Recording Time Chart	134
Card Conversion Chart	80
Card Convert	78
Card Copy	76
Card Delete	76
Card Name	77
Card Protect	77
Card Protector	18
Control Input Mode	87
Control Input/Output Terminals	137
Control Out	59, 104
Conversion Error Chart	80

D

Delay Time	55
Direct Playback	86
Dual Mono Mode	120

E

Edge	93, 95
Elapsed Time	52
Equalizer	126
EZ SETUP	25

F

Fade	58
Format	31
Frame Rate	112

L

Level	93, 95
Line Thru	125

M

MIDI Device ID	110
MIDI Implementation	139
MIDI Note Map	106
MIDI Note Out	109
MIDI Output	84
MIDI Phrases	82
MIDI Receive Channel	108
MIDI Time Base	83
MMC	110
MTC	112
MTC Error Level	115

N

Note Trigger	108
No-voltage/Make-contact	85

O

Output Volume Thru	127
--------------------------	-----

P

Pattern Phrases	62
Phrase Combine	70
Phrase Convert	72
Phrase Copy	68
Phrase Delete	67
Phrase Divide	69
Phrase Name	60
Phrase Truncate	67
Play Volume	54
Playback Point	55
Program Playback	89

R

RDAC	43
RDAC-Grade	44
RDAC-Mode	45
Recording Level	48
Remaining Time	52
Repeat Play	57
RS-232C	21, 119, 137

S

SCRUB	54
Setting Copy	77
Song Phrases	65

T

Time Stretch	71
Trigger Recording	48



This product complies with the requirements of EMCD 2004/108/EC and LVD 2006/95/EC.

For EU Countries

For the USA

FEDERAL COMMUNICATIONS COMMISSION RADIO FREQUENCY INTERFERENCE STATEMENT

This equipment has been tested and found to comply with the limits for a Class B digital device, pursuant to Part 15 of the FCC Rules. These limits are designed to provide reasonable protection against harmful interference in a residential installation. This equipment generates, uses, and can radiate radio frequency energy and, if not installed and used in accordance with the instructions, may cause harmful interference to radio communications. However, there is no guarantee that interference will not occur in a particular installation. If this equipment does cause harmful interference to radio or television reception, which can be determined by turning the equipment off and on, the user is encouraged to try to correct the interference by one or more of the following measures:

- Reorient or relocate the receiving antenna.
- Increase the separation between the equipment and receiver.
- Connect the equipment into an outlet on a circuit different from that to which the receiver is connected.
- Consult the dealer or an experienced radio/TV technician for help.

This device complies with Part 15 of the FCC Rules. Operation is subject to the following two conditions:

- (1) this device may not cause harmful interference, and
- (2) this device must accept any interference received, including interference that may cause undesired operation.

Unauthorized changes or modification to this system can void the users authority to operate this equipment.
This equipment requires shielded interface cables in order to meet FCC class B Limit.

For Canada

NOTICE

This Class B digital apparatus meets all requirements of the Canadian Interference-Causing Equipment Regulations.

AVIS

Cet appareil numérique de la classe B respecte toutes les exigences du Règlement sur le matériel brouilleur du Canada.

For C.A. US (Proposition 65)

WARNING

This product contains chemicals known to cause cancer, birth defects and other reproductive harm, including lead.

For EU Countries



- UK** This symbol indicates that in EU countries, this product must be collected separately from household waste, as defined in each region. Products bearing this symbol must not be discarded together with household waste.
- DE** Dieses Symbol bedeutet, dass dieses Produkt in EU-Ländern getrennt vom Hausmüll gesammelt werden muss gemäß den regionalen Bestimmungen. Mit diesem Symbol gekennzeichnete Produkte dürfen nicht zusammen mit den Hausmüll entsorgt werden.
- FR** Ce symbole indique que dans les pays de l'Union européenne, ce produit doit être collecté séparément des ordures ménagères selon les directives en vigueur dans chacun de ces pays. Les produits portant ce symbole ne doivent pas être mis au rebut avec les ordures ménagères.
- IT** Questo simbolo indica che nei paesi della Comunità europea questo prodotto deve essere smaltito separatamente dai normali rifiuti domestici, secondo la legislazione in vigore in ciascun paese. I prodotti che riportano questo simbolo non devono essere smaltiti insieme ai rifiuti domestici. Ai sensi dell'art. 13 del D.Lgs. 25 luglio 2005 n. 151.
- ES** Este símbolo indica que en los países de la Unión Europea este producto debe recogerse aparte de los residuos domésticos, tal como está regulado en cada zona. Los productos con este símbolo no se deben depositar con los residuos domésticos.
- PT** Este símbolo indica que nos países da UE, a recolha deste produto deverá ser feita separadamente do lixo doméstico, de acordo com os regulamentos de cada região. Os produtos que apresentem este símbolo não deverão ser eliminados juntamente com o lixo doméstico.
- NL** Dit symbool geeft aan dat in landen van de EU dit product gescheiden van huishoudelijk afval moet worden aangeboden, zoals bepaald per gemeente of regio. Producten die van dit symbool zijn voorzien, mogen niet samen met huishoudelijk afval worden verwijderd.
- DK** Dette symbol angiver, at i EU-lande skal dette produkt opsamlles adskilt fra husholdningsaffald, som defineret i hver enkelt region. Produkter med dette symbol må ikke smides ud sammen med husholdningsaffald.
- NO** Dette symbolet indikerer at produktet må behandles som spesialavfall i EU-land, iht. til retningslinjer for den enkelte regionen, og ikke kastes sammen med vanlig husholdningsavfall. Produkter som er merket med dette symbolet, må ikke kastes sammen med vanlig husholdningsavfall.

- SE** Symbolen anger att i EU-länder måste den här produkten kasseras separat från hushållsavfall, i enlighet med varje regions bestämmelser. Produkter med den här symbolen får inte kasseras tillsammans med hushållsavfall.
- FI** Tämä merkintä ilmaisee, että tuote on EU-maissa kerättävä erillään kotitalousjätteistä kunkin alueen voimassa olevien määräysten mukaisesti. Tällä merkinnällä varustettuja tuotteita ei saa hävittää kotitalousjätteiden mukana.
- HU** Ez a szimbólum azt jelenti, hogy az Európai Unióban ezt a terméket a háztartási hulladéktól elkülönítve, az adott régióban érvényes szabályozás szerint kell gyűjteni. Az ezzel a szimbólummal ellátott termékeket nem szabad a háztartási hulladék közé dobni.
- PL** Symbol oznacza, że zgodnie z regulacjami w odpowiednim regionie, w krajach UE produktu nie należy wyrzucać z odpadami domowymi. Produktów opatrzonych tym symbolem nie można utylizować razem z odpadami domowymi.
- CZ** Tento symbol udává, že v zemích EU musí být tento výrobek sbírán odděleně od domácího odpadu, jak je určeno pro každý region. Výrobky nesoucí tento symbol se nesmí vyhazovat spolu s domácím odpadem.
- SK** Tento symbol vyjadruje, že v krajinách EÚ sa musí zber tohto produktu vykonávať oddelene od domového odpadu, podľa nariadení platných v konkrétnej krajine. Produkty s týmto symbolom sa nesmú vyhazovať spolu s domovým odpadom.
- EE** See sümbol näitab, et EL-i maades tuleb see toode olemprügist eraldi koguda, nii nagu on igas piirkonnas määratletud. Selle sümboliga märgitud tooteid ei tohi ära visata koos olmeprügiga.
- LT** Šis simbolis rodo, kad ES šalyse šis produktas turi būti surenkamas atskirai nuo buitinių atliekų, kaip nustatyta kiekviename regione. Šiuo simboliu paženklinėti produktai neturi būti išmetami kartu su buitiniams atliekomis.
- LV** Šis simbols norāda, ka ES valstīs šo produktu jāievāc atsevišķi no mājsaimniecības atkritumiem, kā noteikts katrā reģionā. Produkts ar šo simbolu nedrīkst izmest kopā ar mājsaimniecības atkritumiem.
- SI** Ta simbol označuje, da je treba proizvod v državah EU zbirati ločeno od gospodinskih odpadkov, tako kot je določeno v vsaki regiji. Proizvoda s tem znakom ni dovoljeno odlagati skupaj z gospodinskimi odpadki.
- GR** Το σύμβολο αυτό υποδηλώνει ότι στις χώρες της Ε.Ε. το συγκεκριμένο προϊόν πρέπει να συλλέγεται χωριστά από τα υπόλοιπα οικιακά απορρίμματα, σύμφωνα με όσα προβλέπονται σε κάθε περιοχή. Τα προϊόντα που φέρουν το συγκεκριμένο σύμβολο δεν πρέπει να απορρίπτονται μαζί με τα οικιακά απορρίμματα.



* 0 4 2 3 6 5 6 7 - 0 6 *

Free Manuals Download Website

<http://myh66.com>

<http://usermanuals.us>

<http://www.somanuals.com>

<http://www.4manuals.cc>

<http://www.manual-lib.com>

<http://www.404manual.com>

<http://www.luxmanual.com>

<http://aubethermostatmanual.com>

Golf course search by state

<http://golfingnear.com>

Email search by domain

<http://emailbydomain.com>

Auto manuals search

<http://auto.somanuals.com>

TV manuals search

<http://tv.somanuals.com>