

Rowenta

NEO

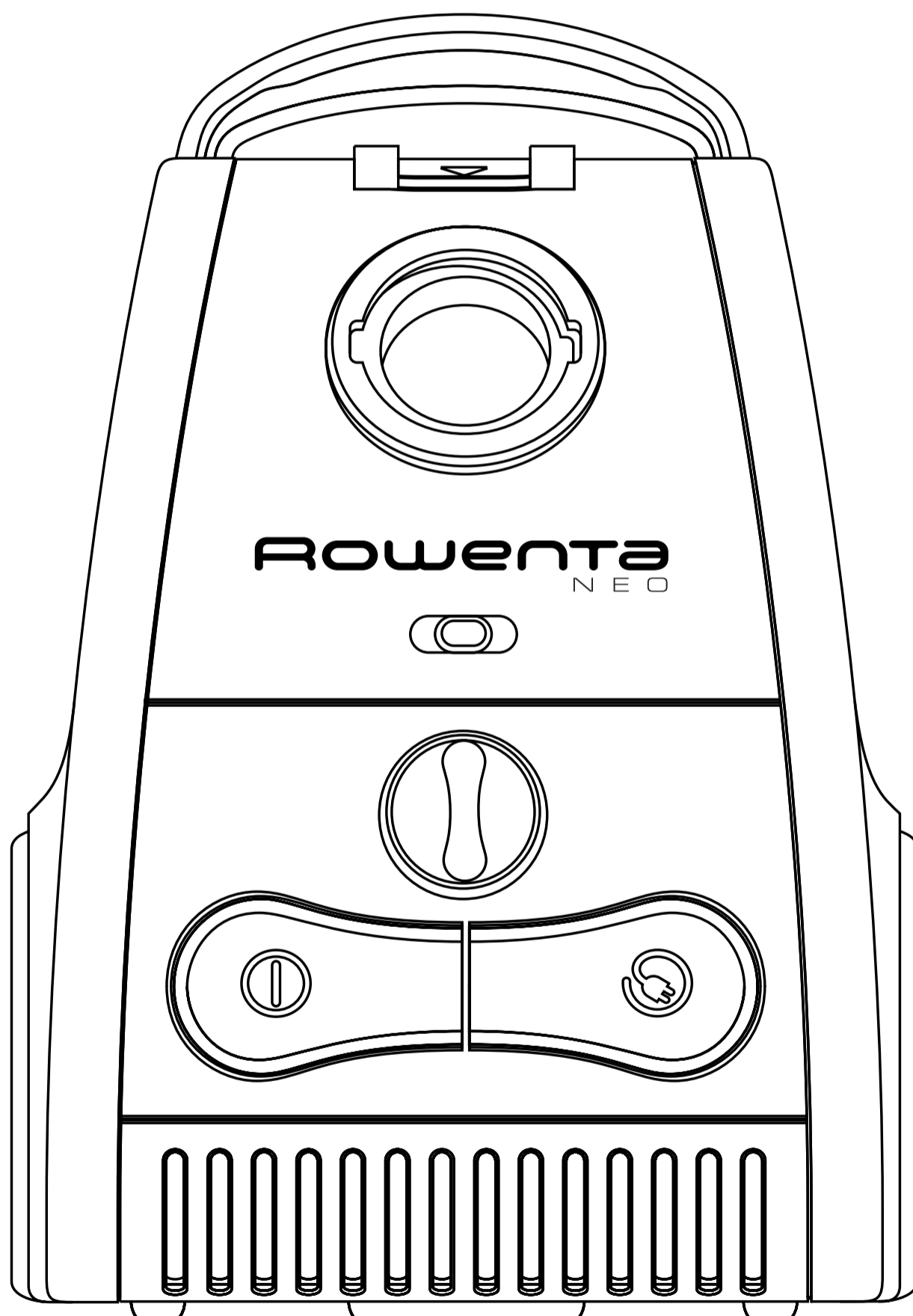

instructions for use
english
ref. 566270

I • DESCRIPTION

english

1. ON/OFF pedal Ⓚ
2. Electronic power control *
3. Suction opening
4. Dustbag full indicator *
5. Cord rewind pedal Ⓛ
6. Air outlet grid
 - a. Foam filter *
 - b. Antibacteria micro-active filter *
 - c. Filter cartridge HEPA FILTER SYSTEM ZR 482 *

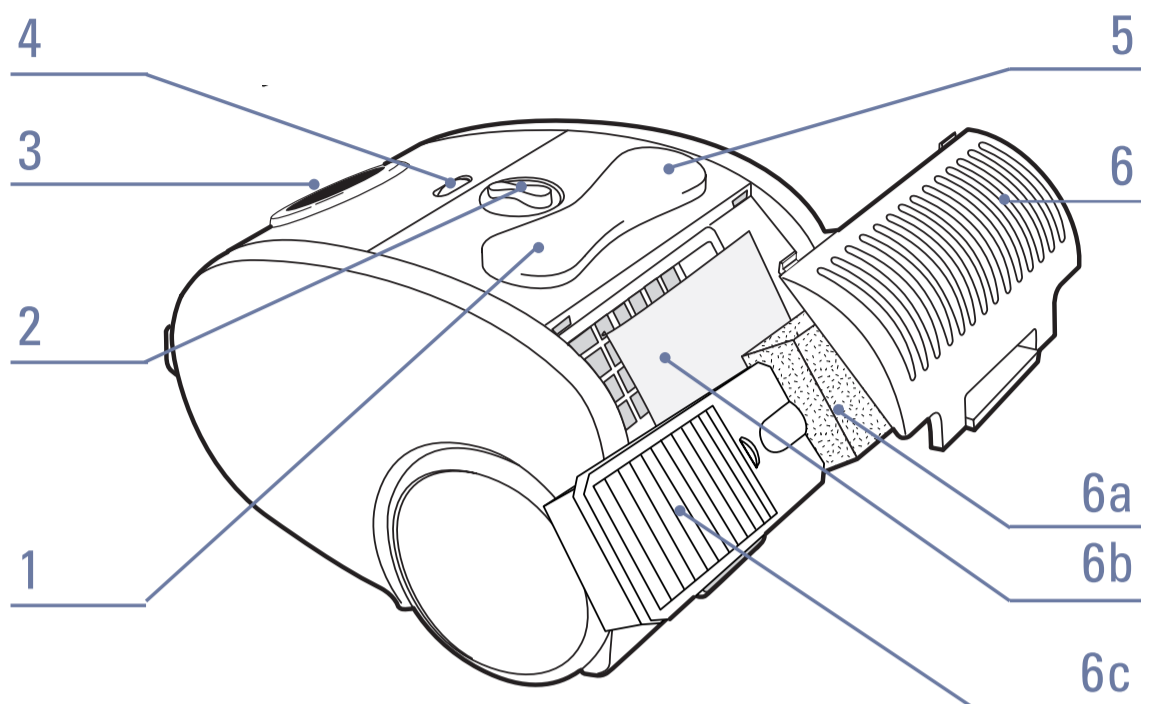

Your vacuum cleaner is equipped either with a foam filter and a micro-active filter(a+b), either with a HEPA filter (c)

7. Dustbag compartment opening
8. Dustbag compartment lid
9. Dustbag compartment
10. Dustbag
11. Motor protection foam filter
12. PARK system
13. Soft touch handle

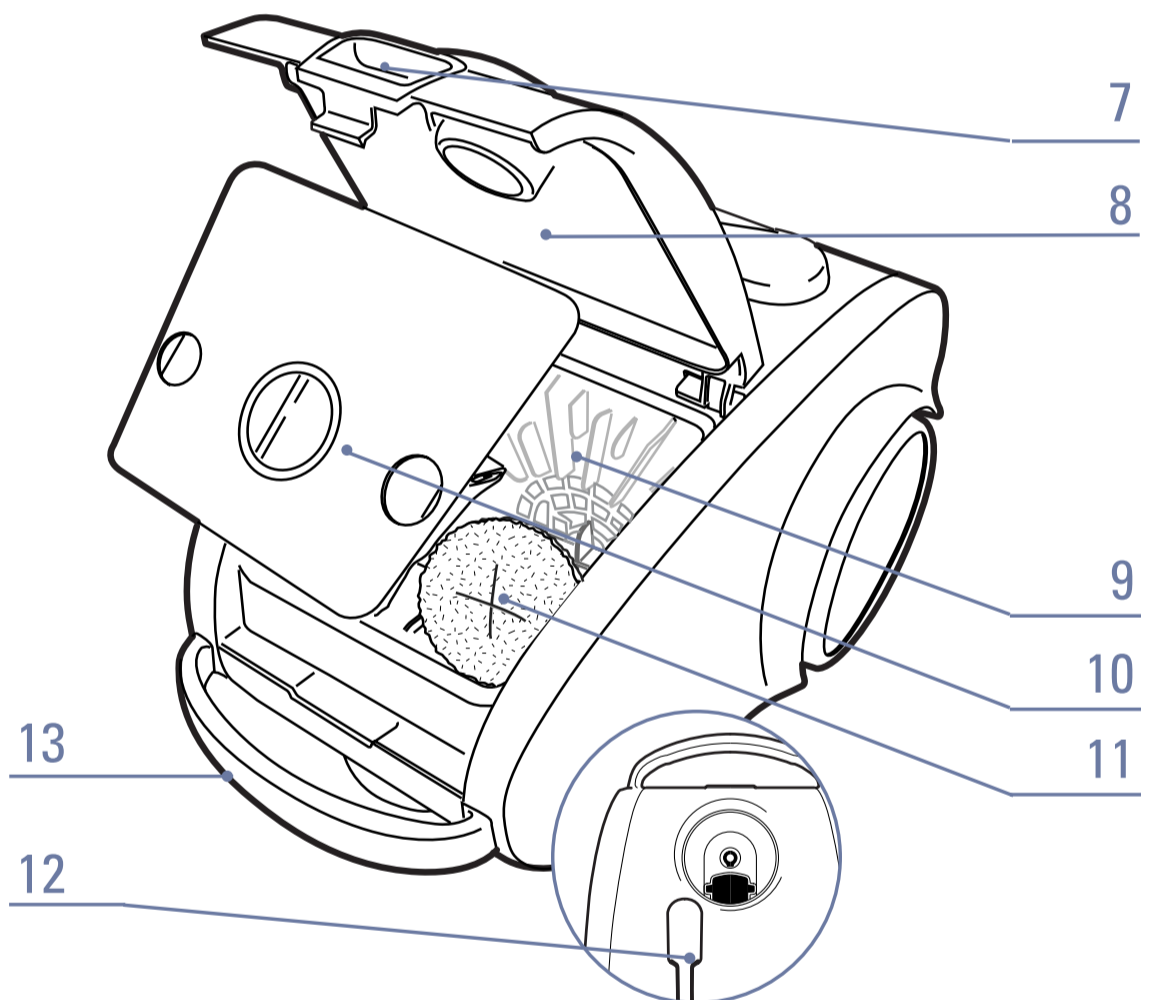

Accessories:

14. Hose connector
15. Suction hose with extra-long handle, mechanical power control, integrated dusting brush *
16. Extension tubes or telescopic tube *
17. Floor nozzle *
18. Delta head *
19. Delta Activ' cleaning head *
20. Crevice tool
21. Upholstery nozzle
22. ZR 480 double-walled antibacteria paper bags *
23. RS-RT 1420 reusable cloth dust-bag *

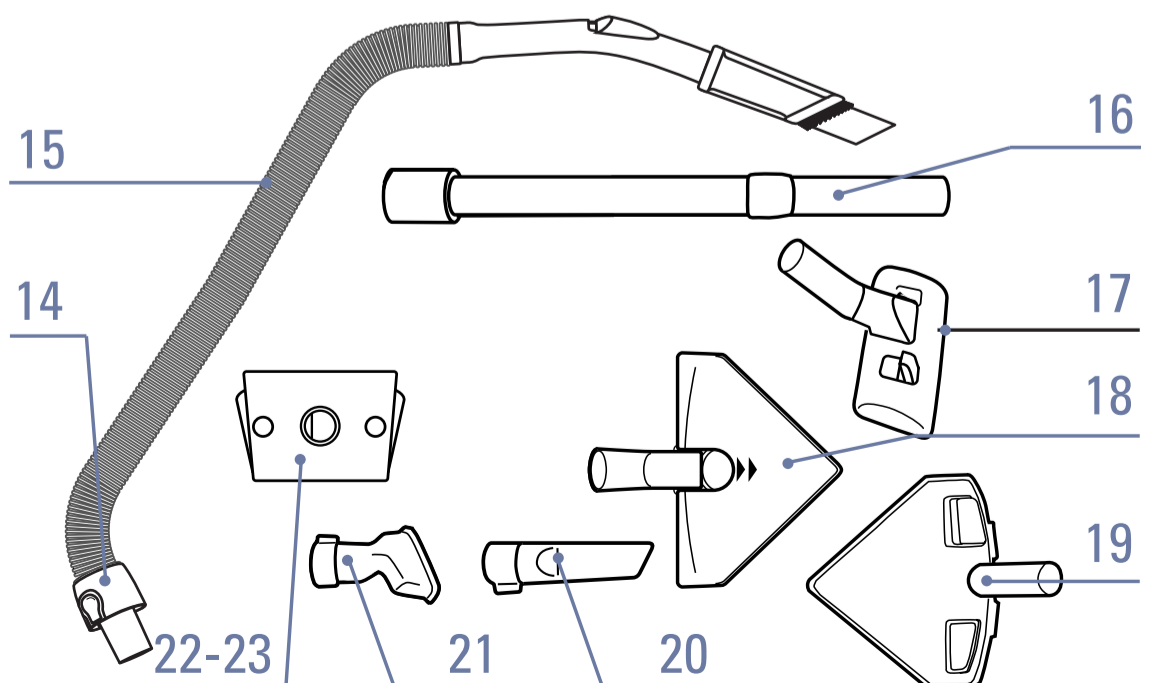

* According to model, it refers to equipment specific to certain models or accessories available as options.

II • HINTS AND PRECAUTIONS

english

Before each use, the supply cord should be completely unwound. Do not allow it to become trapped or pulled over sharp edges. Never lift the appliance by its cord. If you use an extension cord, make sure that it is in perfect condition and appropriate to the power rating of your appliance.

Never unplug the appliance by pulling on the cord.

Only use original Rowenta accessories, dustbags and filters.

Check that all the filters are properly in place. Never turn the appliance on without a dustbag and filters.

For any problems or queries please contact CUSTOMER RELATIONS:

0845 602 1454 - UK (calls charged at local rate)

(01) 412 3000 - IRELAND

or visit our web site : www.rowenta.uk.co

III • BEFORE USE

Assemble your vacuum cleaner.

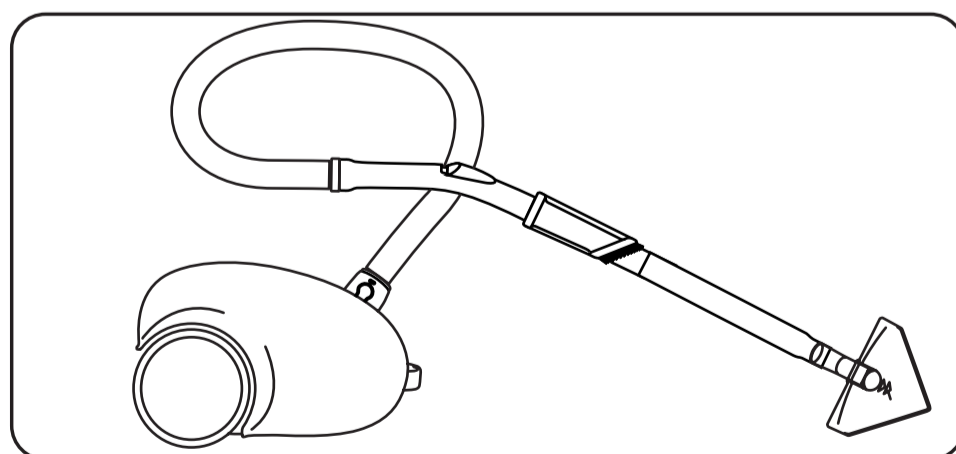
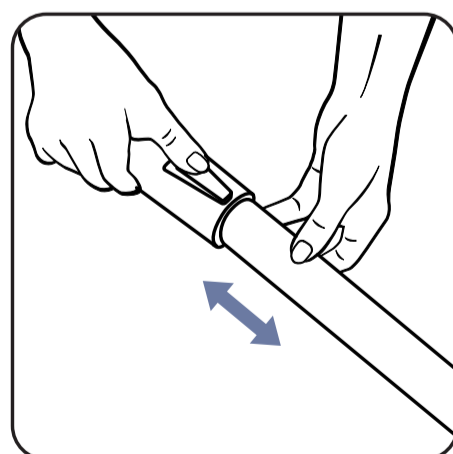
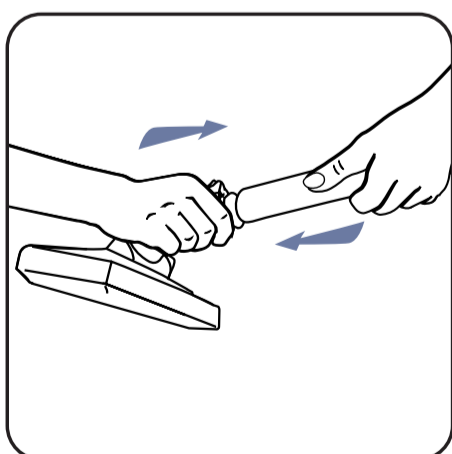
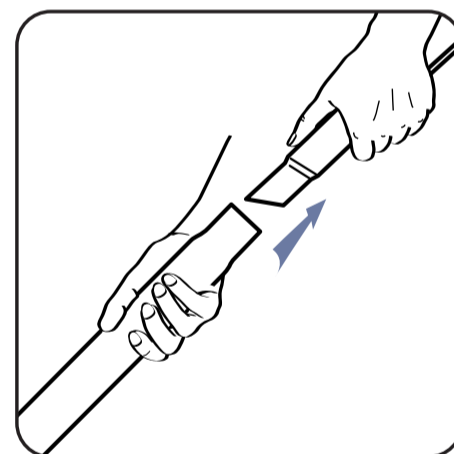
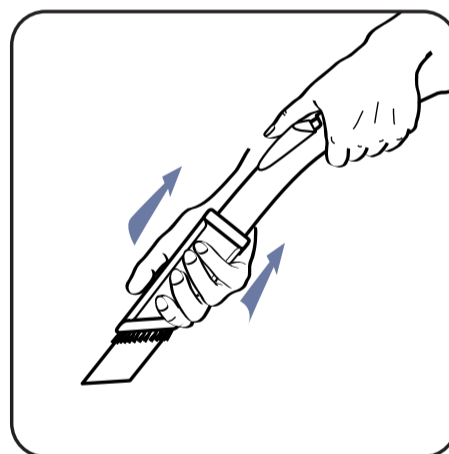
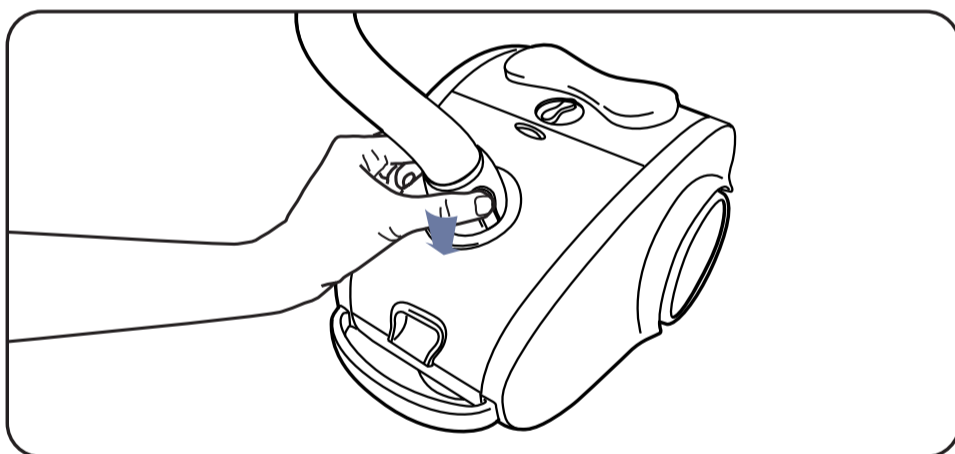

Adjust the length of the telescopic tube (according to model).

IV • VACUUMING

english

Turn on your vacuum cleaner.

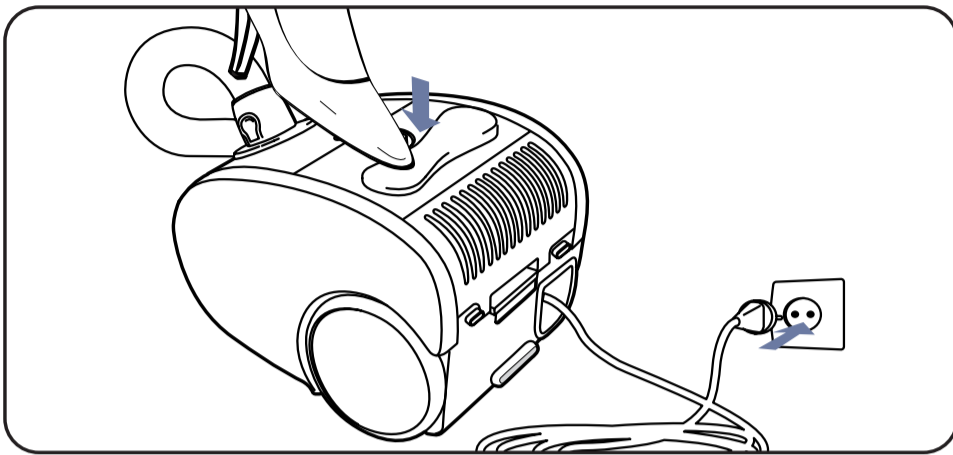

Caution !
Never turn the appliance on without a dustbag and filters.

Adjust the suction power.

With the electronic power control
(according to model*) :

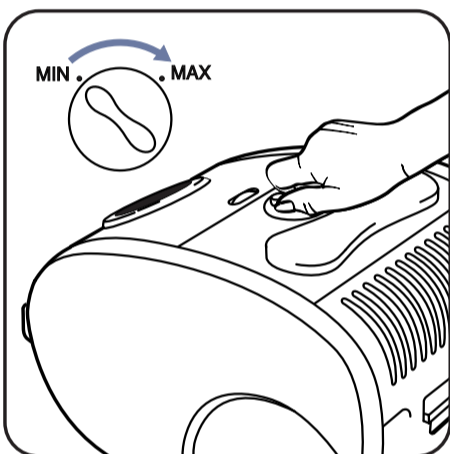

Max : floors
Min : furniture,
delicate
surfaces...

With the mecanical power
control

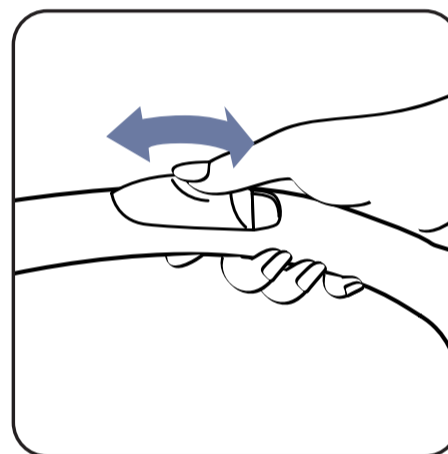

Closed : floors
Open : furniture,
delicate
surfaces...

Turn off your appliance.

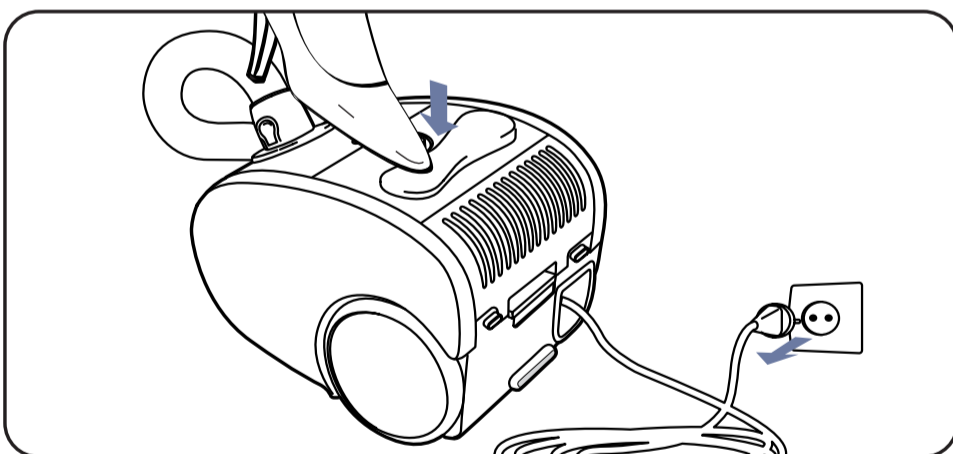

V • STORING

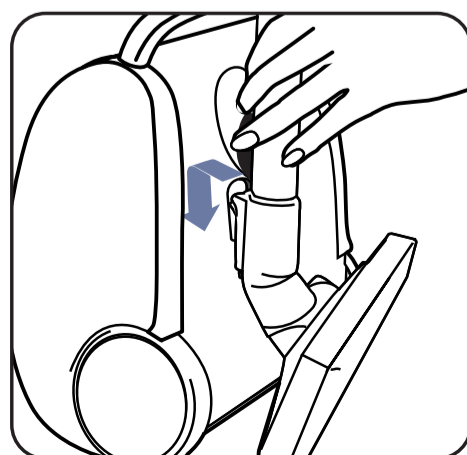
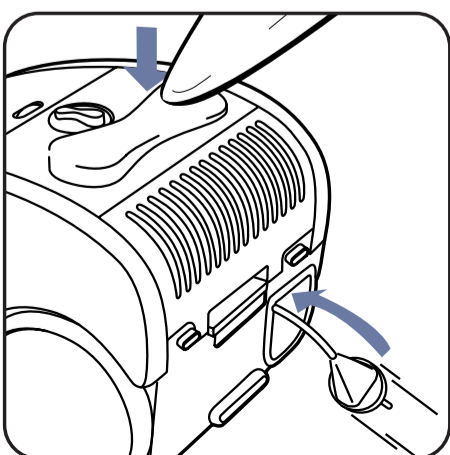

VI • MAINTENANCE AND CLEANING

english

IMPORTANT !

Always turn off and unplug your appliance before maintenance or cleaning

Change the dustbag.

The dustbag full indicator (according to model*) informs you that the bag is full or blocked with dust particles. If the indicator is orange replace the bag or empty the textile filter (with the nozzle lifted off the ground and the power set at its max level).

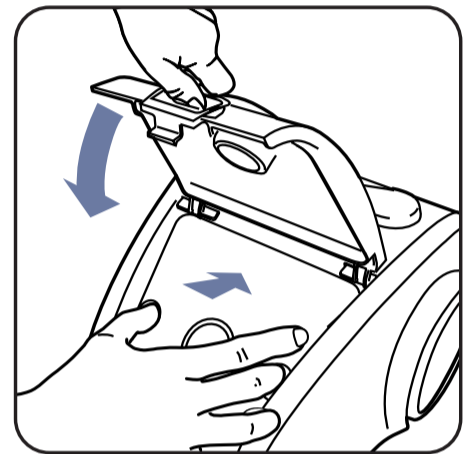
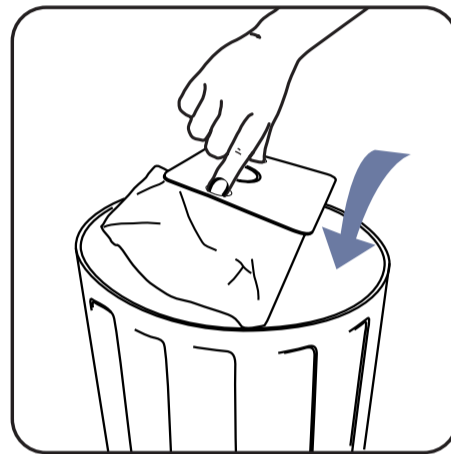
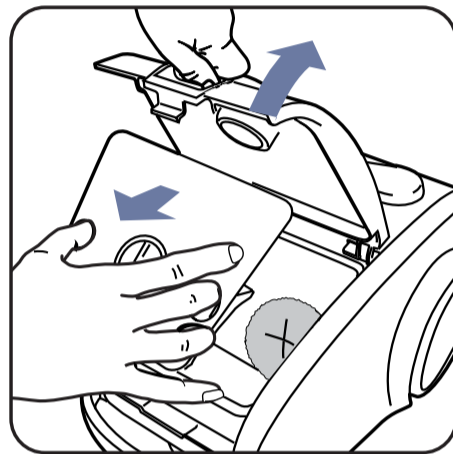
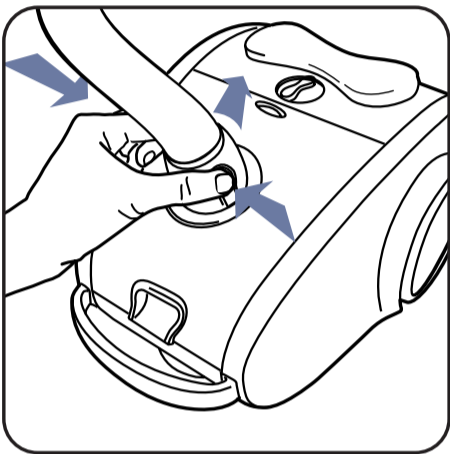

Empty the cloth dustbag (according to model*).

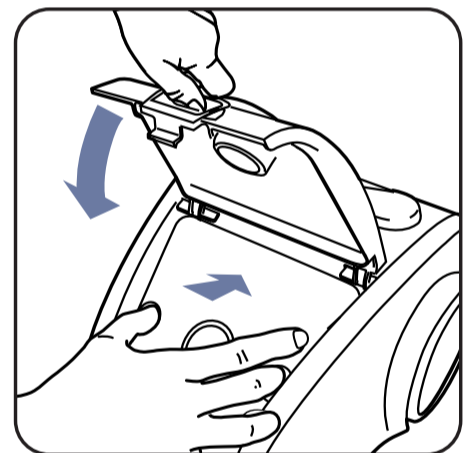
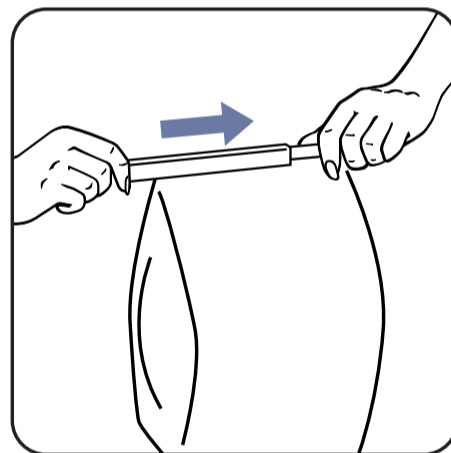
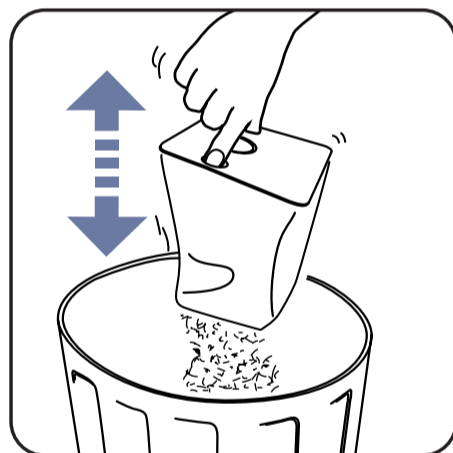
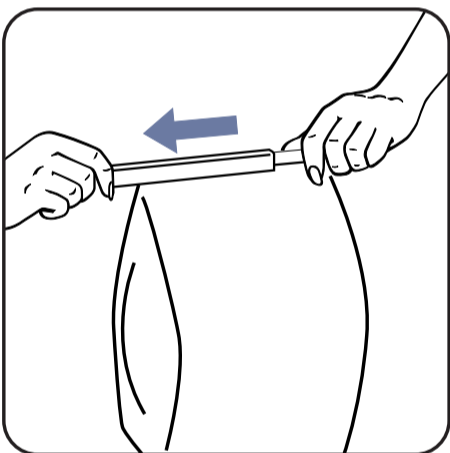

IMPORTANT !

Every five changes of the dustbag :

- clean the motor protection foam filter and the air outlet foam filter (according to model*) with warm soapy water. Rinse and leave them to dry thoroughly before putting them back into place.
- replace the micro-active filter (according to model*).

Clean the motor protection foam filter

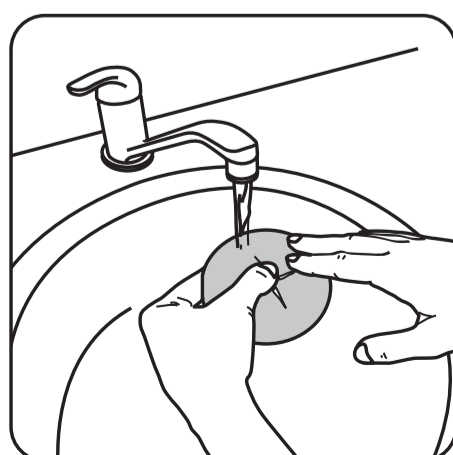
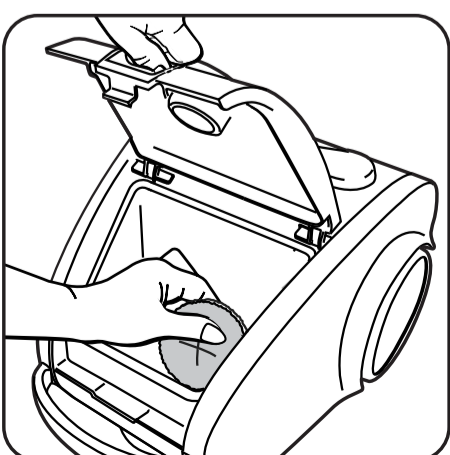

Caution !
The motor protection foam filter should always be in place during use.

Clean the air-outlet foam filter (according to model*).

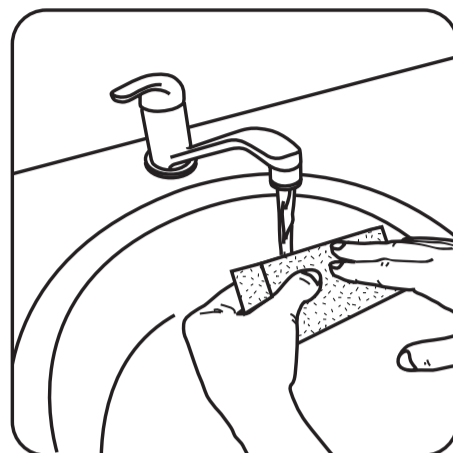
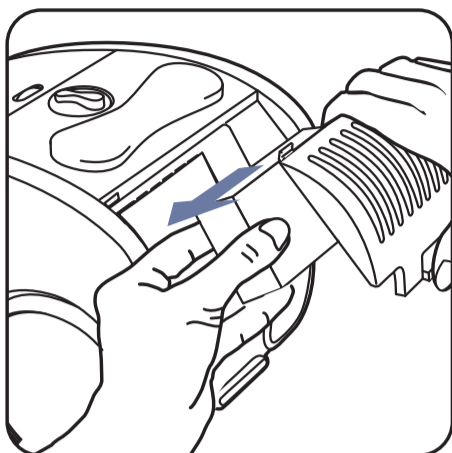

Caution !
Let the foam filter dry completely before placing it back into place.

Replace the micro-active filter (ref. Kit ZR 480) (according to model*).

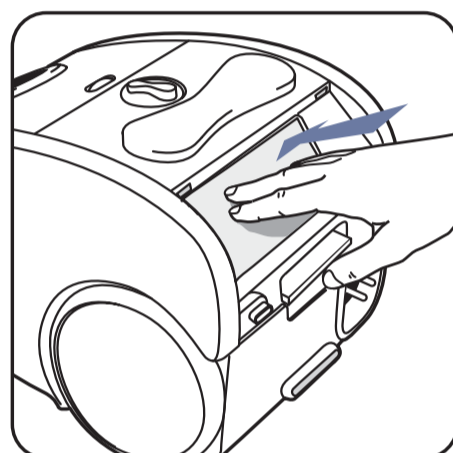
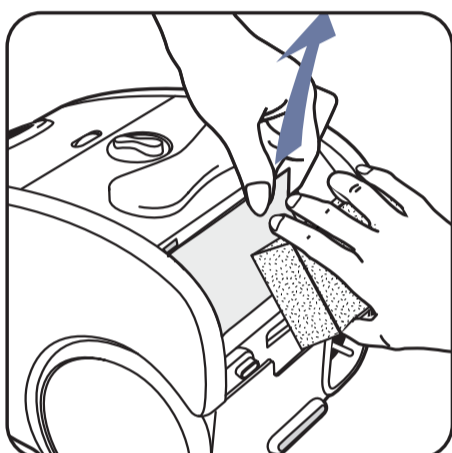

IMPORTANT !
The micro-active filter is under the air outlet foam filter.

Replace the HEPA filter (according to model*).

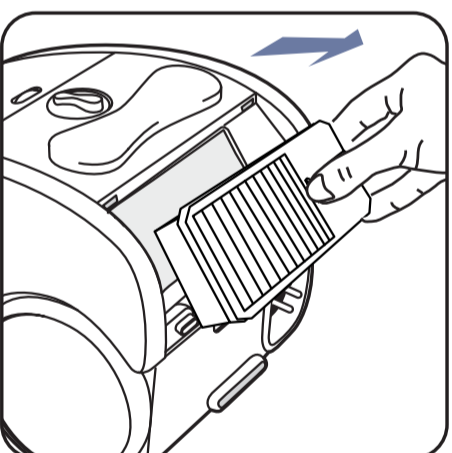

IMPORTANT !
When using the HEPA FILTER SYSTEM, do not forget to remove the air outlet foam filter and the micro-active filter. Never use the HEPA FILTER SYSTEM with a permanent textile dustbag.
Change it every 9 to 12 months (depending on the frequency of use).

Clean your vacuum cleaner

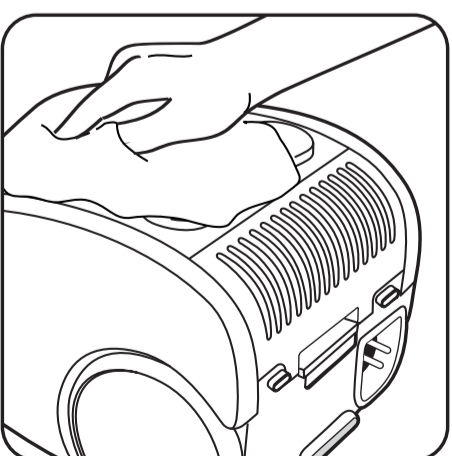

IMPORTANT !
Do not use strong or abrasive cleaning products.

Read the instructions for use carefully and keep them in a safe place.

- Your vacuum cleaner is an electrical appliance: it must only be used under normal operating conditions. The appliance should be used and stored out of the reach of children. Never leave the appliance unattended when it is switched on.
- The appliance is not intended for use by young children or infirm persons without supervision.
- Young children should be supervised to ensure that they do not play with the appliance.
- Always keep nozzles and tube ends well away from eyes and ears.
- Make sure that the operating voltage of your vacuum cleaner is the same as your supply voltage - 230-240v.
- Unplug the appliance by removing the plug from the power outlet:
 - immediately after use,
 - before changing accessories,
 - before maintenance, cleaning or changing the dustbag
- Do not vacuum wet surfaces, any kinds of liquids, hot substances, ultra-fine substances (plaster, cement, ash, etc.) large sharp debris (glass), dangerous products (solvents, stripping compounds, etc.), chemical products (acids, cleaners, etc.), inflammable or explosive products (petrol- or alcohol-based).
- Do not immerse the appliance in water or store it outdoors.
- Do not use the appliance:
 - if it has been dropped and shows signs of damage or functions abnormally.
 - if the supply cord is defectiveIn this case do not open the appliance and call our helpline (overleaf).
- Repairs should only be carried out by specialists using original replacement parts. It is dangerous to try to repair an appliance by yourself.
- Vacuum cleaner supply cords and winding systems must, in all cases, be replaced by our approved Service Centre.
- In accordance with current regulations, before disposing of an appliance no longer needed, the appliance should be made non-operational (by unplugging it and cutting off the electricity supply cord).
- This product has been designed for domestic use only. Any professional use, inappropriate use or failure to comply with the instructions, the manufacturer accepts no responsibility and the guarantee will not apply.

Your appliance conforms to the 73/23 EEC and 89/336 EEC directives.

IMPORTANT!

As soon as your vacuum cleaner starts to malfunction, and before performing any checks:

- Stop the appliance by pressing the Start/Stop switch.
- Unplug the appliance.

Your vacuum cleaner will not start.

- The product is not connected to the mains
Check that the product is correctly plugged in.

Your vacuum cleaner does not suck.

- Either a tool or the hose is blocked
Unblock the tool or the hose.

Your vacuum cleaner suction power is effective, makes more noise than usual, and whistles.

- A tool or the hose is partially blocked
Unblock the tool or the hose.
- The bag is full or blocked by fine dust
Replace the bag or empty the cloth bag.
- The foam filter and microactive filter are full
Clean the foam filters and replace the microactive filter.
- The HEPA filter is full.
Change the HEPA filter.
- The mechanical power control is open
Close the mechanical power control.
- The electronic power control is in the min. position.
Increase power using the electronic power control (except when vacuuming delicate fabrics).

The dust bag full indicator is orange.

- The bag is full
Replace the bag or empty the cloth bag.
- The nozzle is difficult to remove
Open the mechanical power control or reduce its power.

The power cord does not fully retract.

- The cord slows down as it is retracted
Pull out the cord until completely extended and press on the retraction button.

If the problem persists contact our Helpline:

0845 602 1454 - UK (calls charged at local rate)

(01) 412 3000 - IRELAND

Free Manuals Download Website

<http://myh66.com>

<http://usermanuals.us>

<http://www.somanuals.com>

<http://www.4manuals.cc>

<http://www.manual-lib.com>

<http://www.404manual.com>

<http://www.luxmanual.com>

<http://aubethermostatmanual.com>

Golf course search by state

<http://golfingnear.com>

Email search by domain

<http://emailbydomain.com>

Auto manuals search

<http://auto.somanuals.com>

TV manuals search

<http://tv.somanuals.com>