

13. WARRANTY

Royal Sovereign International warrants the equipment sold is free from defects in material and workmanship for a period of One (1) year for Parts and Labor from the date of installation, excluding lamination rollers which are warranted for Six (6) months. This warranty is extended only to the original purchaser. This warranty is the only warranty made by Royal Sovereign International and cannot be modified or amended. Royal Sovereign's sole and exclusive liability and the customer's sole and exclusive remedy under this warranty shall be, at Royal Sovereign's option, to repair or replace any such defective part or product. These remedies are only available if Royal Sovereign's examination of the product discloses to Royal Sovereign's satisfaction that such defects actually exist and were not caused by misuse, neglect, attempt to repair, unauthorized alternation or modification, incorrect line voltage, fire, accident, flood or other hazard.

The warranty made herein is in lieu of all other warranties, expressed or implied, including any warranty or merchantability or fitness for a particular purpose. Royal Sovereign will not be liable for personal damage or personal injury (unless primarily caused by its negligence), loss of profit, or other incidental or consequential damages arising out of the use or inability to use this equipment.

LIMITED WARRANTY

This warranty specifically does not cover damage to laminating rollers caused by knives, razor blades, or any sharp objects or abrasives, or failure caused by adhesives, or damage caused by lifting, tilting and/or any attempt to position the machine other than rolling on the installed castors or feet on even surfaces, or improper use of the machine. Warranty repair or replacement by Royal Sovereign or its authorized Reseller(s) does not extend the warranty beyond the initial one year period from the date of installation. Unauthorized customer alterations will void this warranty.

CORPORATE HEADQUARTERS

Royal Sovereign International Inc.

2 Volvo Drive, Rockleigh, NJ 07647 U.S.A.

TEL : +1) 800-397-1025 FAX : +1) 201-750-1022

E-mail : info@royalsovereign.com

RS Holland B.V.

Columbusstraat 25 - 3165 AC Rotterdam,
The Netherlands

E-mail : paulchoi@royalsovereign.com

henryabrahamian@royalsovereign.com

Royal Sovereign Inc. <Oversea Sales Office>

1001, World Meridian II, 426-5, Gasan-dong,
Geumcheon-gu, Seoul, 153-759, KOREA

TEL : +82)2-2025-8800 FAX : +82)2-2025-8830

E-mail : sales@royalsovereign.com

RS Canada Inc.

164 Oakdale Road, Toronto, Ontario M3N 2S5
CANADA

TEL : +1) 416-741-8400 FAX : +1) 416-741-8185

E-mail : info@royalsovereign.com

RS International Australia PTY. LTD.

30 Prime Drive, Seven Hills, NSW 2147, Australia

TEL : +61) 2-9674-2127

FAX : +61) 2-9674-2027

E-mail : salesaust@royalsovereign.com

OWNER'S MANUAL

RSH-380 Laminator



Read all instructions carefully before use.

For any Customer Support needs please choose the
Customer Support tab on www.royalsovereign.com

Royal Sovereign International Inc.
www.royalsovereign.com

TABLE OF CONTENTS

TOPIC	PAGE
1. Introduction	3
2. Package Contents	3
3. Safety Precautions	4
4. Parts	4
5. Control Pane	5
6. Film Loading and Threading	6.7
7. Before Laminatingl	8
8. Operation Instructions	9.10
9. Recommended Temperature and Speed Settings	11
10. Maintenance.....	12
11. Trouble Shooting Guide	12
12. Specifications	13
13. Warranty.....	14

1. INTRODUCTION

Thank you for purchasing a Royal Sovereign RSH-380 Table Top Laminator. It has been designed and manufactured to provide years of continuous service. For complete operating and maintenance information please read this instruction manual thoroughly. Upon receipt of your laminator thoroughly inspect the box, machine and all other contents. It is imperative that any shipping damage is reported and a claim is filed with the delivering carrier immediately upon receipt.

2. PACKAGE CONTENTS

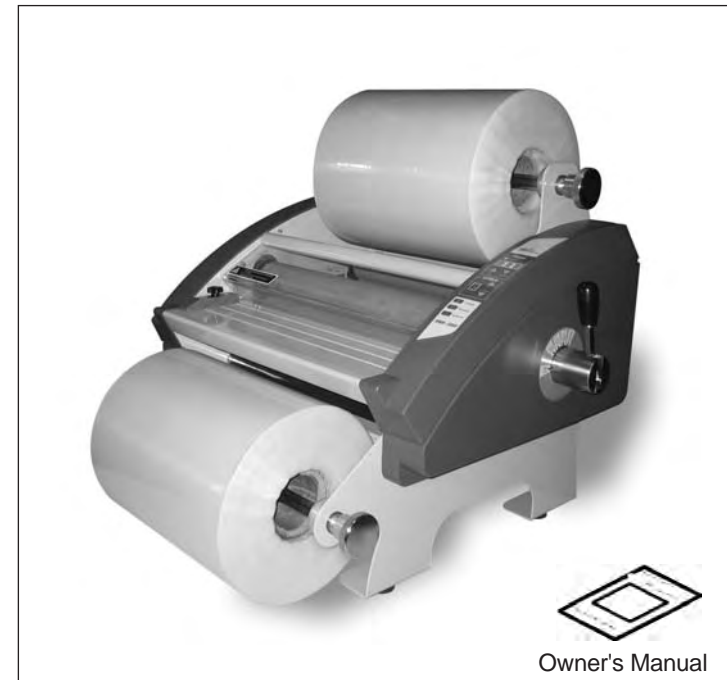

3. SAFETY PRECAUTIONS

Failure to comply with any of the following safety procedures could result in serious injury. Please read the instructions carefully and keep for future reference.

1. Only a licensed electrician should install wiring and outlet for the laminator.
2. Ensure the unit is plugged into a properly grounded outlet with the correct voltage.
3. Keep hands and clothing (i.e. Neckties) away from rollers. The rollers are pinch points that can trap body parts or clothing and cause serious injury.
4. Keep flammable and wet objects away from the machine.
5. Place machine on a level surface.
6. Avoid excessive sunlight, humidity and extreme temperatures.
7. Ensure the unit is turned off, cooled, and unplugged from the outlet prior to moving and/or repairing.
8. Keep out of reach of children.
9. Only Royal Sovereign authorized maintenance and service technicians should make repairs.
10. Do not attempt to laminate items that exceed total recommended material thickness for the unit
11. When cleaning the machine, don't use flammable sprays or materials.
12. Do not touch the rollers when they are hot or place foreign objects inside the machine.
13. Do not cover the surface of the machine until the machine has completely cooled.

4. PARTS

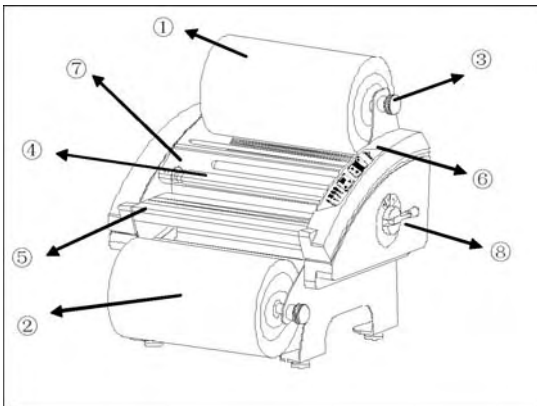

- 1.FILM-UPPER
- 2.FILM-LOWER
- 3.TENSION CONTROL KNOB
- 4.TOP HOT ROLLER
- 5.FRONT FEED TABLE
- 6.CONTROL PANEL
- 7.SAFETY SHIELD
- 8.PRESSURE LEVER

5. CONTROL PANEL



< TEMPERATURE >

This button is for changing the temperature of upper and lower rollers,

Press the up button to increase temperature or the down button to decrease temperature.

[range 20 °C(68 °F) through 150 °C(302 °F)]

< SPEED >

This button is used to change the speed of the rollers.

(Settings 1 - 9)

< T-CHECK >

To Check current upper and lower roller temperature.

Display automatically returns to previous settings after 5 blinks.

< REVERSE >

This button is used to reverse the rollers to undo jams and correct misfed documents.

< RUN/STOP >

This button is used to Run and Stop the machine.

6. FILM LOADING & THREADING

< Thermal Film Loading & Threading >

Loading Film

1. Remove the upper and lower film shafts from the machine and load the films (do not tighten the core screws at this time)
2. To load the top film, insert 1" core as shown on Figure 1 (Note the direction of the film wound)

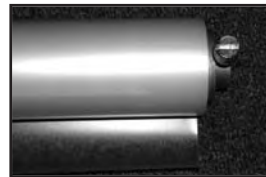

Figure 1

3. Insert the shaft as shown in Figure 2.



Figure 2

4. Insert the core plug on the left hand side. Figure 3



Figure 3

5. Align and center the film and tighten the two core screws. Figure 4



Figure 4

6. Repeat steps 2 through 4 to load the lower film. (Please note the direction of the film wound for the bottom roll). Figure 5
7. Load the upper and lower film shafts on the machine.



Figure 5

< Film Threading >

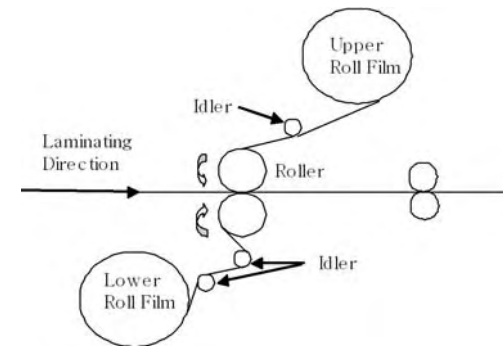

1. Turn the power switch on ("I" position). (The Power switch is located on the rear the unit)
2. Complete the steps in the "Loading Film" section.
3. Set the desired temperature.
4. Remove the Front Feed Table.
5. Pull down the upper film over the Safety Shield to the lower film; align and center the lower film to the upper film and tighten the 2 lower bolt core screws. (Figure 1)
6. Rewind the upper film until it aligns with the safety cover.
7. Thread the film over the Lower Idle Bar and underneath the safety shield until the film rests on the upper roller. Figure 2
8. Put the Front Feed Table back on and close the Safety Shield. Figure 3
9. Press the Run button and thread the film using the Laminating Threading Card. Figure 4

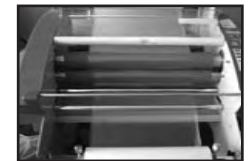

Figure 1



Figure 2

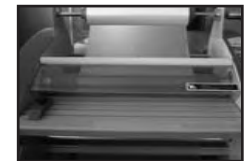

Figure 3



Figure 4

7. BEFORE LAMINATING

1. For High Quality Lamination
 - Refer to the "Recommended Temperature and Speed Settings" section before laminating.
 - The Upper and lower film tension must be same.
2. Changing Roll film.
 - While laminating, if the roll film needs to be replaced, press the 'RUN/STOP' button .

Once the rollers stop, cut the upper and lower film, remove and replace with new rolls of film.
3. After lamination
 - "Hot Spots" on the rollers may occur when the machine is idle. To help prevent "Hot Spots" you must run the sample paper between the front rollers and stop the machine while the sample paper is in between the rollers. You must leave the sample paper in this position until you laminate again.
 - After laminating with Thinflex™, use "Cleaning Paper" to clean the rollers.

8. OPERATING INSTRUCTIONS

1. Turn the laminator on, the power switch is located on the rear of the machine.
2. Adjust the tension of the upper and lower films.
 - Clockwise to tighten and Counter
 - Clockwise to loosen.
3. Set the pressure lever to the "Laminating mode"
4. Choose appropriate laminating temperature by pressing the "UP" or "DOWN" button.
5. When desired temperature is met an alarm will sound and "READY" will appear on the display.
6. Press the "RUN/STOP" button. (If rollers don't run check that the safety shield is completely closed).
7. Position the item to be laminated on the Front Feed Table.
8. Adjust the film tension or laminating speed if necessary.
9. Press the "RUN/STOP" button when your lamination is finished.
10. After finishing your work, set the pressure lever to the "Hard Board/6mm"
11. Turn the Power switch off

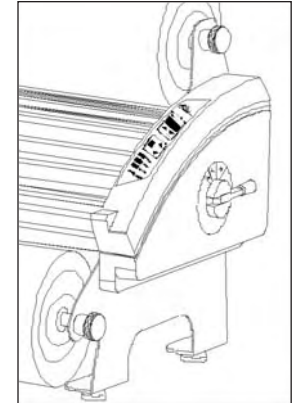

NOTE:

- * Stand by mode : If no activity is made within 30 minutes after each use the machine will automatically switch to stand by mode.
- * Auto power off mode : If the machine is in standby mode and no activity is made for 90 minutes the machine will automatically power off.

9. RECOMMENDED TEMPERATURE AND SPEED SETTINGS

1) The cross cutter is located on the rear exit table of the machine.

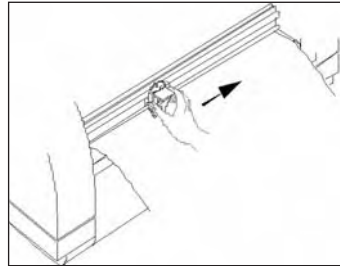

2) After lamination, move the cutter approximately to the center of the application at the desired point of detachment.

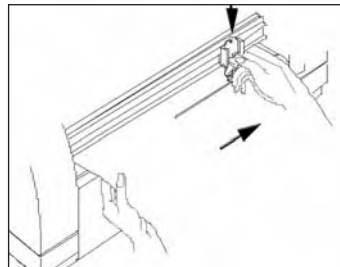

3) Grasp film with one hand, press the cutter downward into the application and slide it first to one end of the application, then to the other end to complete the cut.

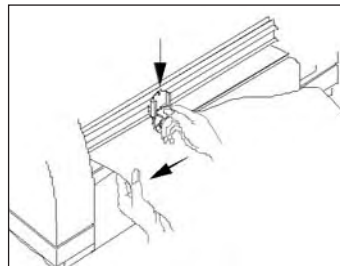

Paper	speed	Temperature	Function
80 g/m ²	4~5	100~110 °C (212~230 °F)	25~38mic (1~1.5mil)
Paper(both side can be used)			
120g/m ²	3~4		
200g/m ²			
color paper			
80g/m ²	2~4	100~110 °C (212~230 °F)	75mic(3mil)
Paper(both side can be used)			
120g/m ²			
200g/m ²			
color paper			
80g/m ²	4~5	100~115 °C (230~239 °F)	100mic(4mil)
Paper(both side can be used)			
120g/m ²	2~3		
200g/m ²			
color paper			
80g/m ²	2~4	120~125 °C (248~257 °F)	250mic(5mil)
Paper(both side can be used)			
120g/m ²	2~3	130~135 °C (266~275 °F)	
200g/m ²			
color paper			

10. MAINTENANCE

1. Do not apply any cleaning fluids to the rollers, certain fluids may cause damage.
2. Do not clean rollers with sharp objects, use adhesive remover to clean resin off the rollers.
3. Use a damp cloth with only water to clean the body of the machine.
4. Store machine in a dry clean area.

11. TROUBLE SHOOTING GUIDE

Problem	Possible Cause	Possible Solution
Rollers do not operate after the RUN/STOP button is pressed	<ol style="list-style-type: none"> 1. Safety cover is opened. 2. Power cord is not plugged in 	<ol style="list-style-type: none"> 1. Check to make sure the safety shield is closed. 2. Check the power cord.
Roller is not heating	Call your authorized dealer	Call your authorized dealer
Result of lamination is wavy.	<ol style="list-style-type: none"> 1. Film tension is unbalanced. 2. lower idler bar is not located in proper position 	<ol style="list-style-type: none"> 1. Adjust film tension by rotating tension handle 2. Push idler bar up
Result of lamination is not clear	1. Temperature is lower or speed is higher than recommended	1. Adjust speed and temperature

12. SPECIFICATIONS

Description	RSH-380
Power supply	AC 100, 200, 220 ~ 240V 50/60Hz 120V 60Hz
Power consumption	1500W
Max laminating width	380mm / 15"
Film thickness	25~250 mic / 1~10mil
Max laminating speed	5m/min / 16.4ft/min
Ready time	8min
Heating method	Hot roller
Driving motor	DC geared
Max Temperature control	150 °C / 302 °F
Speed control	9 settings
Transport type	4 Roller
Film core size	1", 2.25", 3"
Cross cutter	Yes
Hot lamination	Yes
Mounting thickness	6mm / 0.24"
Reverse	Yes
Unit dimensions (w × d × h)	550 × 690 × 605(mm) / 21.5" × 27" × 24"
Unit weight	45kg / 99 lbs
Carton dimensions (w × d × h)	800 × 750 × 650(mm) / 31.5" × 29.5" × 25.5"
Carton weight	57kg / 126 lbs

Free Manuals Download Website

<http://myh66.com>

<http://usermanuals.us>

<http://www.somanuals.com>

<http://www.4manuals.cc>

<http://www.manual-lib.com>

<http://www.404manual.com>

<http://www.luxmanual.com>

<http://aubethermostatmanual.com>

Golf course search by state

<http://golfingnear.com>

Email search by domain

<http://emailbydomain.com>

Auto manuals search

<http://auto.somanuals.com>

TV manuals search

<http://tv.somanuals.com>