

RuggedSwitch™ RS900G

10-Port Managed Ethernet Switch with Gigabit Uplink Ports

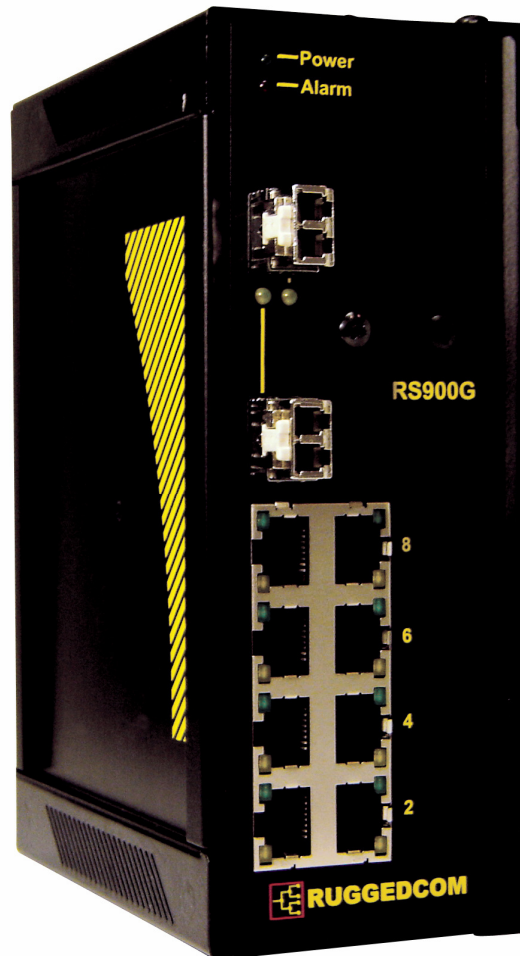

Installation Guide

www.ruggedcom.com

Federal Communications Commission Radio Frequency Interference Statement

This equipment has been tested and found to comply with the limits for a Class A digital device pursuant to Part 15 of the FCC Rules. These limits are designed to provide reasonable protection against harmful interference when the equipment is operated in a commercial environment. This equipment generates, uses and can radiate radio frequency energy and, if not installed and used in accordance with the instruction manual, may cause harmful interference to radio communications. Operation of this equipment in a residential area is likely to cause harmful interference in which case the user will be required to correct the interference at his expense.

Caution

This product contains a laser system and is classified as a "CLASS 1 LASER PRODUCT".

Use of controls or adjustments or performance of procedures other than those specified herein may result in hazardous radiation exposure. This product contains no user serviceable parts. Attempted service by unauthorized personnel shall render all warranties null and void.

Should this device require service see the "Warranty" section of this installation guide.

Important

This unit should be installed in a restricted access location where access can only be gained by service personnel or users who have been instructed about the reasons for the restrictions applied to the location and about any precautions that shall be taken; and access is through the use of a tool or lock and key, or other means of security, and is controlled by the authority responsible for the location.

Trademarks:

Ethernet is a trademark of Xerox Corporation

RuggedSwitch, RuggedRated, ROS and eRSTP are trademarks of RuggedCom® Inc.

Table of Contents

1	Product Overview	4
1.1	RS900G Family Front Panel Description	5
1.2	RS900G Family Bottom View	6
2	Installation	7
2.1	DIN Rail Mounting.....	7
2.2	Power Supply Wiring and Grounding.....	8
2.2.1	HI Power Supply Wiring and Grounding	8
2.2.2	DC Power Supply Wiring and Grounding	9
2.3	HIPOT (Dielectric Strength) Testing	10
2.4	Failsafe Output Wiring and Specifications	11
2.5	RS232 Port Wiring	12
2.6	RJ45 Ports – Signal Description	13
3	Technical Specifications.....	14
3.1	Operating Environment.....	14
3.2	Power Supply Specifications.....	14
3.3	Failsafe Relay Specifications.....	14
3.4	Twisted Pair Data Port Specifications.....	15
3.5	Fiber Optical Port Specifications.....	15
3.6	Physical Dimensions.....	16
3.7	Agency Approvals.....	17
4	Warranty.....	17

1 Product Overview

The RuggedSwitch™ RS900G is an industrially hardened, fully managed Ethernet switch providing dual fiber optical Gigabit Ethernet ports and eight Fast Ethernet copper ports. Designed to operate reliably in harsh industrial environments, the RS900G provides a high level of immunity to electromagnetic interference and heavy electrical surges typical of environments found in electric utility substations, factory floors or in curb side traffic control cabinets. An operating temperature range of -40°C to +85°C coupled with hazardous location certification, a galvanized steel enclosure and optional conformal coating allows the RS900G to be placed in almost any location.

The embedded Rugged Operating System (ROS™) provides advanced networking features such as Enhanced Rapid Spanning Tree (eRSTP™), Port Rate Limiting and a full array of intelligent functionality for high network availability and manageability.

Ethernet Ports

- 2 - Fiber Optic Gigabit-Ethernet Ports
- 8 - Fast Ethernet Ports (10/100BaseTX)
- Full compliance with IEEE: 802.3, 802.3u and 802.3z
- Non-blocking, store and forward switching
- Full duplex operation and flow control (IEEE 802.3x)
- Industry standard fiber optical connectors: LC, SC, SFP
- Bi-Directional simplex fiber support
- Long haul optics allow Gigabit distances up to 70km

RuggedRated™ for Reliability in Harsh Environments

- Meets IEEE 1613 (electric utility substations)
- Exceeds IEC 61850-3 (electric utility substations)
- Exceeds IEEE 61800-3 (variable speed drive systems)
- Exceeds IEC 61000-6-2 (generic industrial environment)
- Exceeds NEMA TS-2 (traffic control equipment)
- Hazardous Location Certification: Class 1 Division 2
- -40 to +85°C operating temperature (no fans)
- Conformal coated circuit boards (optional)
- 20 AWG galvanized steel enclosure

Universal Power Supply Options

- Fully integrated power supply
- Universal high-voltage range: 88-300VDC or 85-264VAC
- Dual low-voltage DC inputs (12, 24 or 48 VDC)
- CSA/UL 60950 safety approved to +85°C

Simple Plug and Play Operation

- Automatic learning of up to 8192 MAC addresses
- Auto-negotiation on all 10/100BaseTX ports
- Auto-MDI/MDIX (crossover) on all 10/100BaseTX ports
- LED indicators for link, activity and speed

ROS™ Advanced Network Management

- Enhanced Rapid Spanning Tree (eRSTP™)
- Quality of Service (802.1p) for real-time traffic
- Port rate limiting: 128kbps to 8Mbps
- VLAN (802.1q) with double tagging
- IGMP Snooping for multicast filtering
- Port configuration, status, statistics, mirroring, security
- Loss of link management on fiber ports
- Web-based, Telnet, CLI management interfaces
- SNMP v2 and RMON
- Rich set of diagnostics with logging and alarms

1.1 RS900G Family Front Panel Description

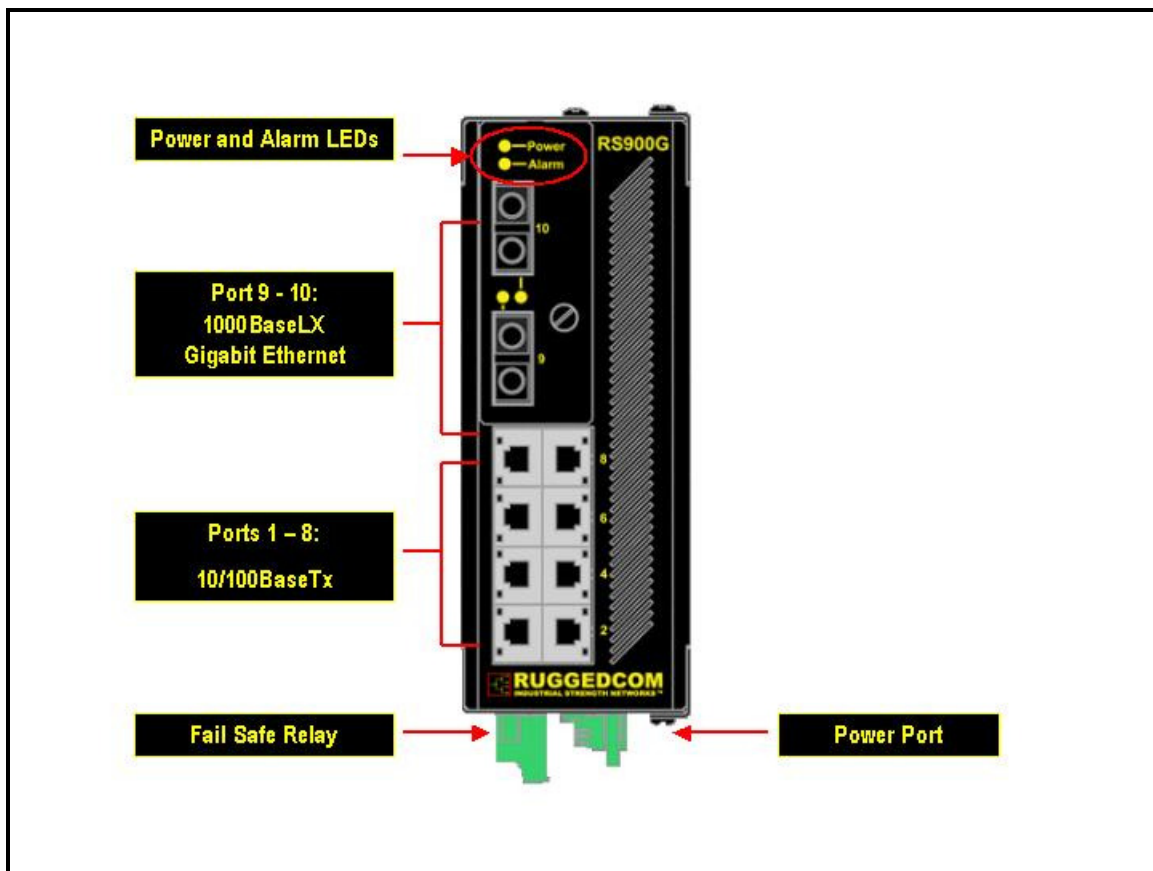

Figure 1.1.1 RS900G Front Panel View

ITEM	Activity	Comments
LINK LED (Yellow)	Solid	Link Established
	Blinking	Tx/Rx Activity
Power LED	Solid	Power On
Alarm LED	Solid	Alarm condition exists

1.2 RS900G Family Bottom View

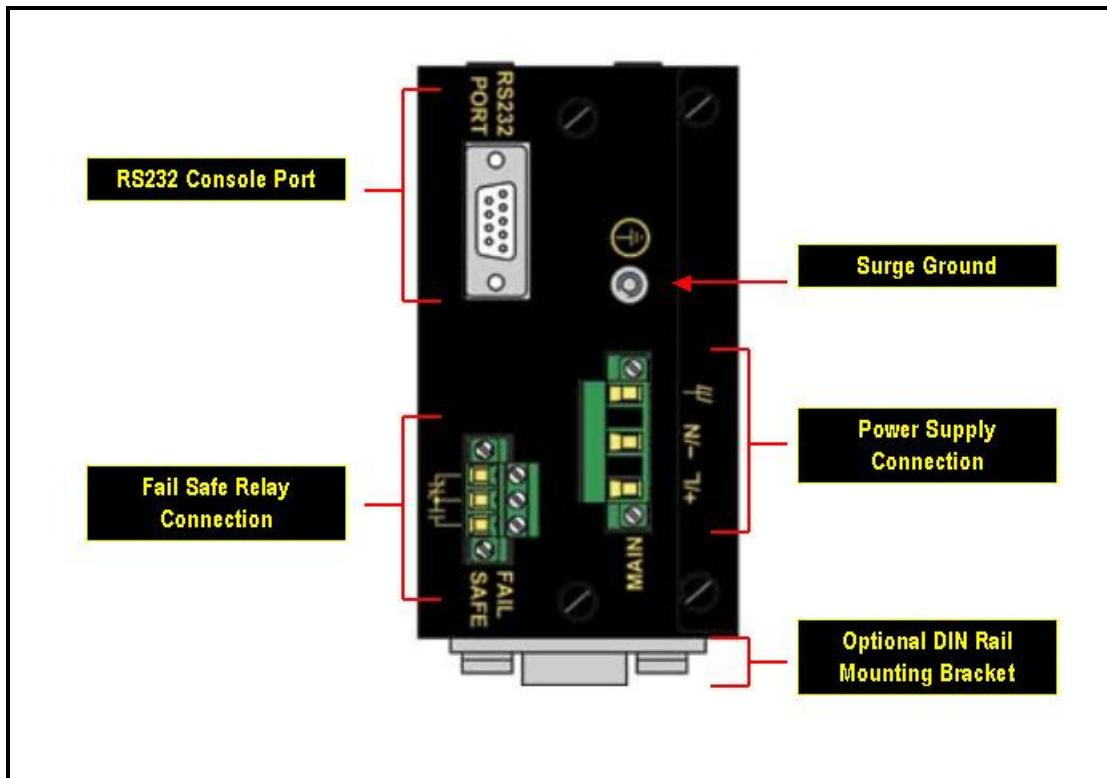

Figure 1.2.1 RS900G Family Bottom View

2 Installation

2.1 DIN Rail Mounting

An optional DIN rail mounting bracket is available for the RS900G. Figure 2.1.1 details mounting instructions for the standard 1" DIN Rail.

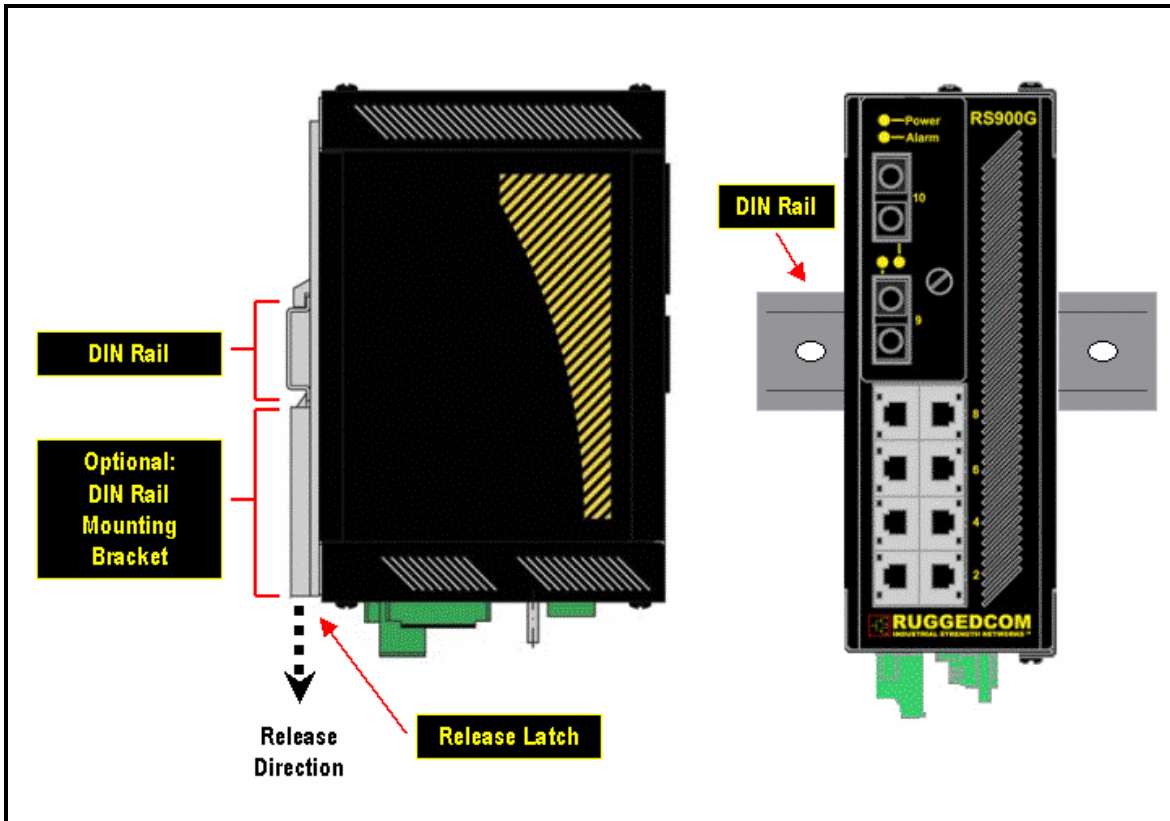

Figure 2.1.1 RS900G Family DIN Rail Mounting

2.2 Power Supply Wiring and Grounding

2.2.1 HI Power Supply Wiring and Grounding

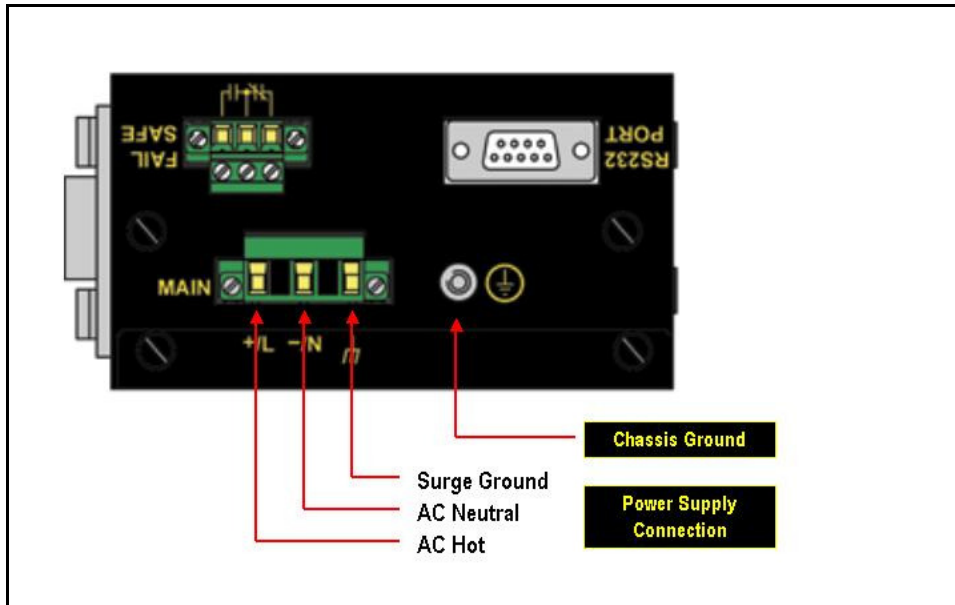

Figure 2.2.1 RS900G Family Power Supply Inputs

The RS900G family HI power supply inputs are identical and are connected as follows:

1. **+L** should be connected to AC (Hot)
2. **-N** should be connected to AC (Neutral)
3. **Surge Ground** is connected to the Chassis Ground via a braided cable or other appropriate grounding wire. Surge Ground is used as the ground conductor for all surge and transient suppression circuitry internal to the RS900G unit.
4. **Chassis Ground** should be connected to the AC Ground terminal

Notes:

1. Equipment must be installed according to the applicable country wiring codes.
2. Surge Ground **MUST** be disconnected from the Chassis Ground during HIPOT (dielectric strength) testing.
3. All line-to-ground transient energy is shunted to the Surge Ground terminal. In cases where users require the inputs to be isolated from ground, remove the ground braid between Surge and Chassis Ground. Note that all line-to-ground transient protection circuitry will be disabled.

2.2.2 DC Power Supply Wiring and Grounding

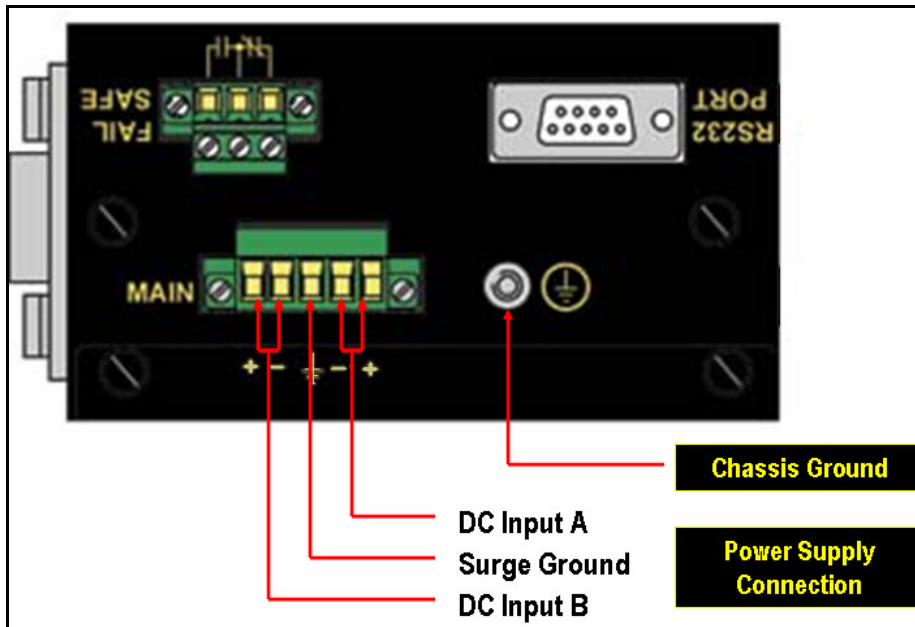

Figure 2.2.2.1 DC Power supply wiring and grounding diagram

The RS900 low voltage DC power supply features reverse polarity protection and dual independent inputs. This feature allows the connection of two DC sources with the same nominal voltage to provide redundant power supply inputs. The DC source must be connected to the DC inputs according to the polarity markings on the unit.

Notes:

1. Equipment must be installed according to the applicable country wiring codes.
2. Surge Ground should be connected to Chassis Ground via a braided cable or other appropriate ground wire.
3. Chassis Ground must be connected to the protective earth.
4. All line-to-ground transient energy is shunted to the Surge Ground terminal. In cases where users require the DC inputs to be isolated from ground, remove the ground braid between Surge and Chassis Ground. Note that all line-to-ground transient protection circuitry will be disabled.

2.3 HIPOT (Dielectric Strength) Testing

Units which are to be “HIPOT” tested in the field must have the braided ground cable disconnected (see Figure 2.3.1) during the HIPOT test. This is required in order to prevent the transient/surge suppression circuitry, which is connected to Surge Ground (see Figure 2.3.1), from being activated during the HIPOT test.

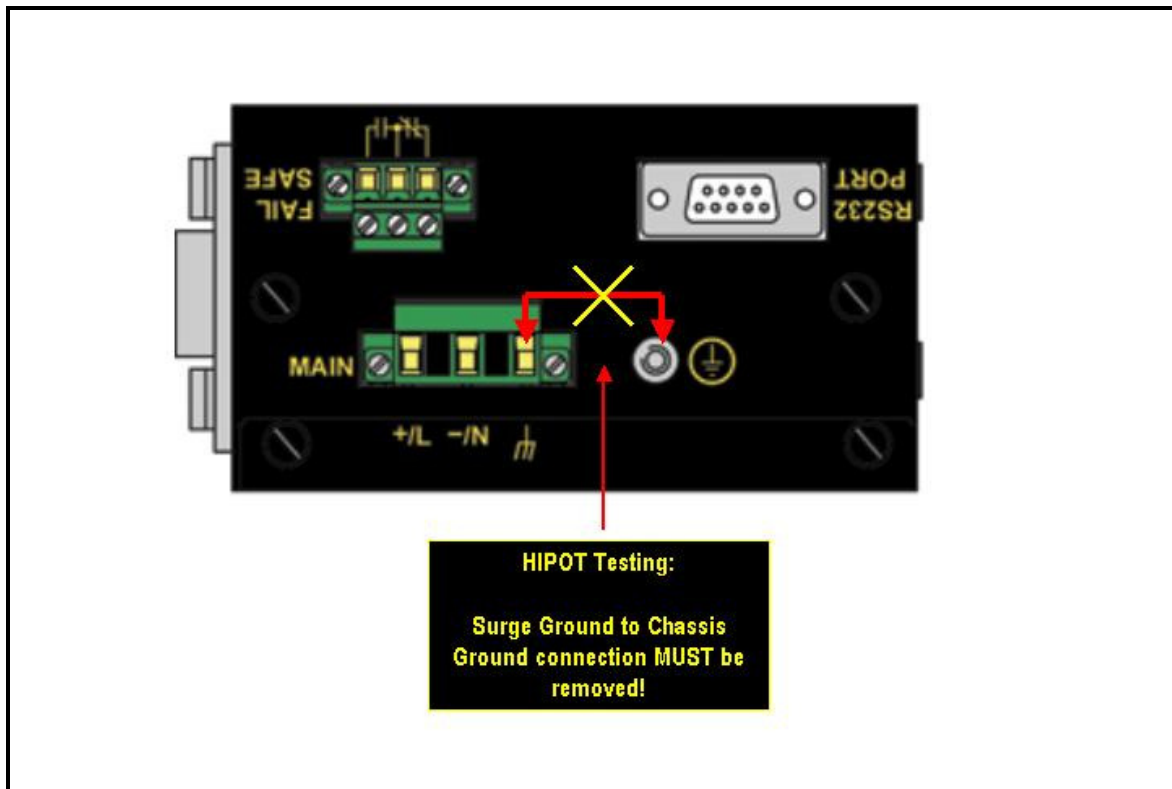

Figure 2.3.1 HIPOT (Dielectric Strength) Testing

2.4 Failsafe Output Wiring and Specifications

The “Failsafe” output relay is provided to signal critical error conditions that may occur on the RS900G series switch. The contacts are energized upon power up of the unit and remain energized until an alarm condition or power loss occurs.

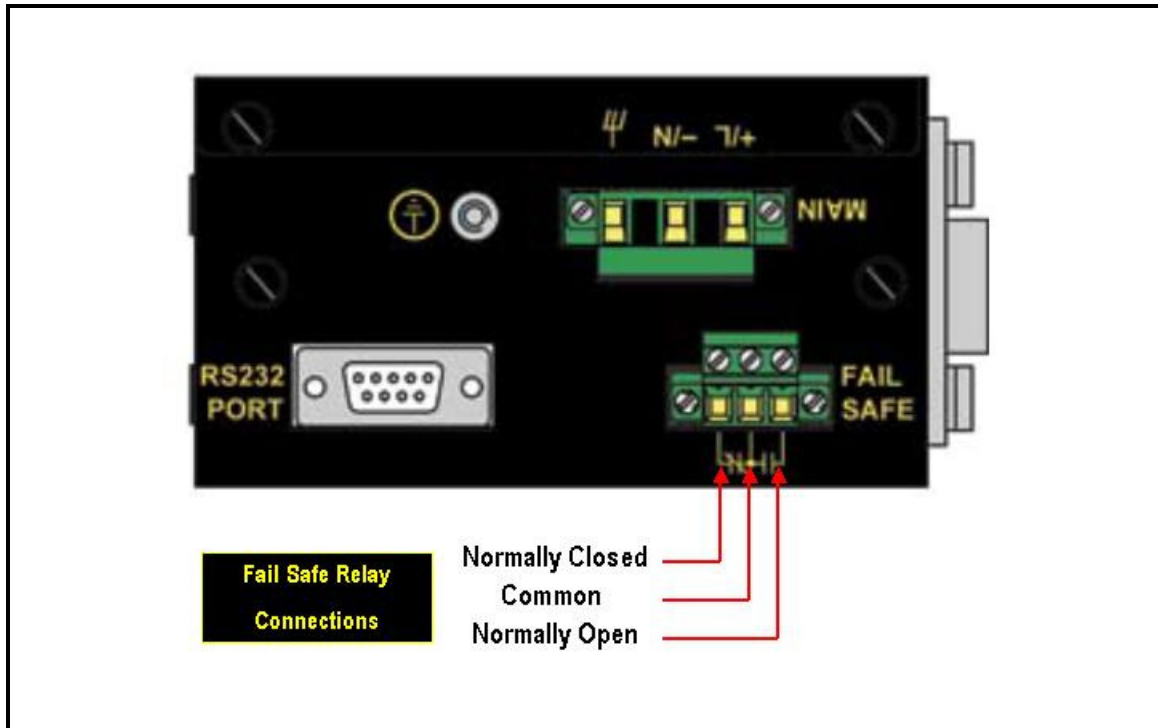

Figure 2.4.1 RS900G Family Failsafe Output Relay

2.5 RS232 Port Wiring

The RS232 port is used for configuring the unit. A straight-through serial cable with a DB-9 connector is required. There is no need to crossover the Transmit and Receive signals from the PC side since this has been done internally as shown in the figure below.

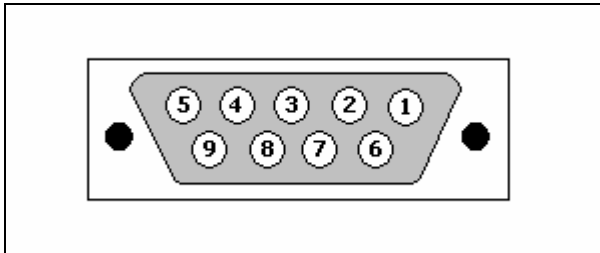

Fig 2.5.1 RS232 Female DCE pin-out

Pin	Signal
1	No Connection
2	Transmit Data
3	Receive Data
4	No Connection
5	Ground
6	No Connection
7	No Connection
8	No Connection
9	No Connection

Table 2.5.1 RS232 Female DCE pin-out

NOTE: This port is not intended to be a permanent connection and the cable shall be less than 2m (6.5 ft) in length.

2.6 RJ45 Ports – Signal Description

The RS900G series switches have several 10/100BaseTX ports that allow connection to standard CAT-5 UTP cable with RJ45 male connectors. The RJ45 receptacles are directly connected to the chassis ground on the unit and can accept shielded CAT-5 cables. If shielded cables are used, care must be taken to ensure the shielded cables do not form a ground loop via the shield wire and the RJ45 receptacles at either end. Fig. 2.6.1 shows the RJ45 port pins configuration.

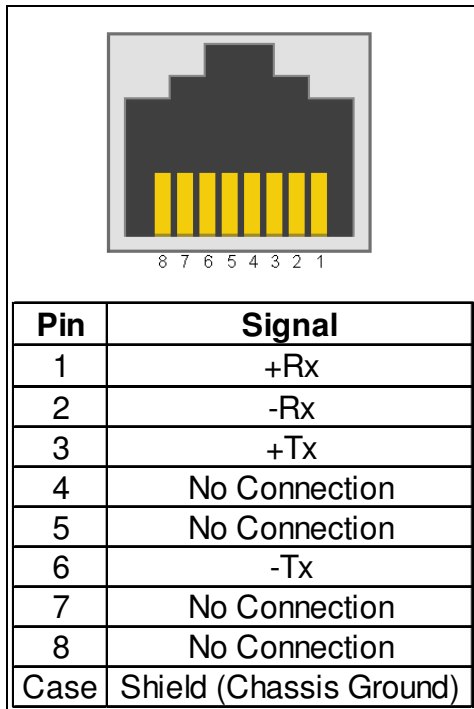

Fig. 2.6.1 shows the RJ45 port pins configuration.

NOTE: RuggedCom does not recommend the use of CAT-5 cabling of any length for critical real-time substation automation applications. However, transient suppression circuitry is present on all copper ports to protect against damage from electrical transients and to ensure IEC 61850-3 and IEEE 1613 Class 1 conformance. This means that during the transient event communications errors or interruptions may occur but recovery is automatic.

RuggedCom also does not recommended to use these ports to interface to field devices across distances which could produce high levels of ground potential rise, (i.e. greater than 2500V) during line to ground fault conditions.

3 Technical Specifications

3.1 Operating Environment

Parameter	Range	Comments
Ambient Operating Temperature	-40 to 85°C	Ambient Temperature as measured from a 30cm radius surrounding the center of the RS900G enclosure.
Ambient Relative Humidity	5% to 95%	Non-condensing
Ambient Storage Temperature	-40 to 85°C	
Operating Altitude	0 to 15240m (0 to 50000 ft)	Over temperature range of -40 to 85°C

3.2 Power Supply Specifications

Power Supply Type	Minimum Input	Maximum Input	Fuse Rating	Isolation	Maximum Power Consumption
12 – 24 VDC	10 VDC	36 VDC	3.15A (T)	1.5 kV DC	10W
24 VDC	18 VDC	36 VDC	3.15A (T)	1.5 kV DC	
48 VDC	36 VDC	59 VDC / 72VDC	3.15A (T)	1.5 kV DC	
HI (125/250 VDC) ¹ HI (110/230 VAC) ¹	88 VDC 85 VAC	300 VDC 265 VAC	3.15A (T)	4 kV AC 5.5 kV DC	

NOTES:

1. This is the same power supply for both AC and DC.
2. (T) denotes time-delay fuse
3. For continued protection against risk of fire, replace only with same type and rating of fuse.

3.3 Failsafe Relay Specifications

Parameter	Value
Max Switching Voltage	30VAC, 80VDC
Rated Switching Current	0.3A @ 30VAC 1A @ 30VDC, 0.3A @ 80VDC

Figure 1 - Failsafe Relay Specification

NOTES:

1. Resistive Load.
2. For Class-2 circuits only.

3.4 Twisted Pair Data Port Specifications

Data Port	Media	Distance	Connector Type
10/100 Mbps	Cat 5 UTP or STP	100m	RJ45

3.5 Fiber Optical Port Specifications

For maximum flexibility RuggedCom Inc. offers a number of different transceiver choices for Gigabit fiber optical communications. The following table details fiber optic specifications based on the order code / transceiver selected at time of ordering.

Order Code	Mode / Connector	Tx λ (nm)	Cable Type ²	Tx Pwr (dBm) ³ (Min/Max)	Rx Sensitivity (dBm) ³	Rx Saturation (dBm) ³	Typical Distance ¹ (km)
2LCMM	MM / LC	850	50 μ /125	-9.5 / -4	-20	0	0.5
2LC10	SM / LC	1310	9 μ /125	-9.5 / -3	-22	-3	10
2LC25	SM / LC	1310	9 μ /125	-5 / 0	-22	-3	25
2SC10	SM / SC	1310	9 μ /125	-10 / -3	-22	-3	10
2SC25	SM / SC	1310	9 μ /125	-7 / -3	-24	-3	25
SFP	MM / LC	850	50 μ /125	-8.5 / -4	-22	-3	0.5
SFP	SM / LC	1310	9 μ /125	-9 / -3	-24	0	10
SFP	SM / LC	1310	9 μ /125	-7 / -3	-26	-3	25
SFP ⁴	SM / LC	1550	9 μ /125	-5 / 0	-26	0	50
SFP ⁴	SM / LC	1550	9 μ /125	0 / 5	-26	0	80
SFP	SM / SC Simplex	1310	9 μ /125	-9 / -3	-22	-3	10
SFP ⁴	SM / SC Simplex	1490	9 μ /125	-9 / -3	-22	-3	10

NOTES:

1. Maximum segment length is greatly dependent on factors such as fiber quality, and number of patches and splices. Please consult RuggedCom sales associates when determining maximum segment distances.
2. All cabling is duplex type unless otherwise specified.
3. All optical power numbers are listed as dBm averages.
4. These transceivers utilize a distributed feedback (DFB) type laser and are rated for -20°C to +85°C operation only.

3.6 Physical Dimensions

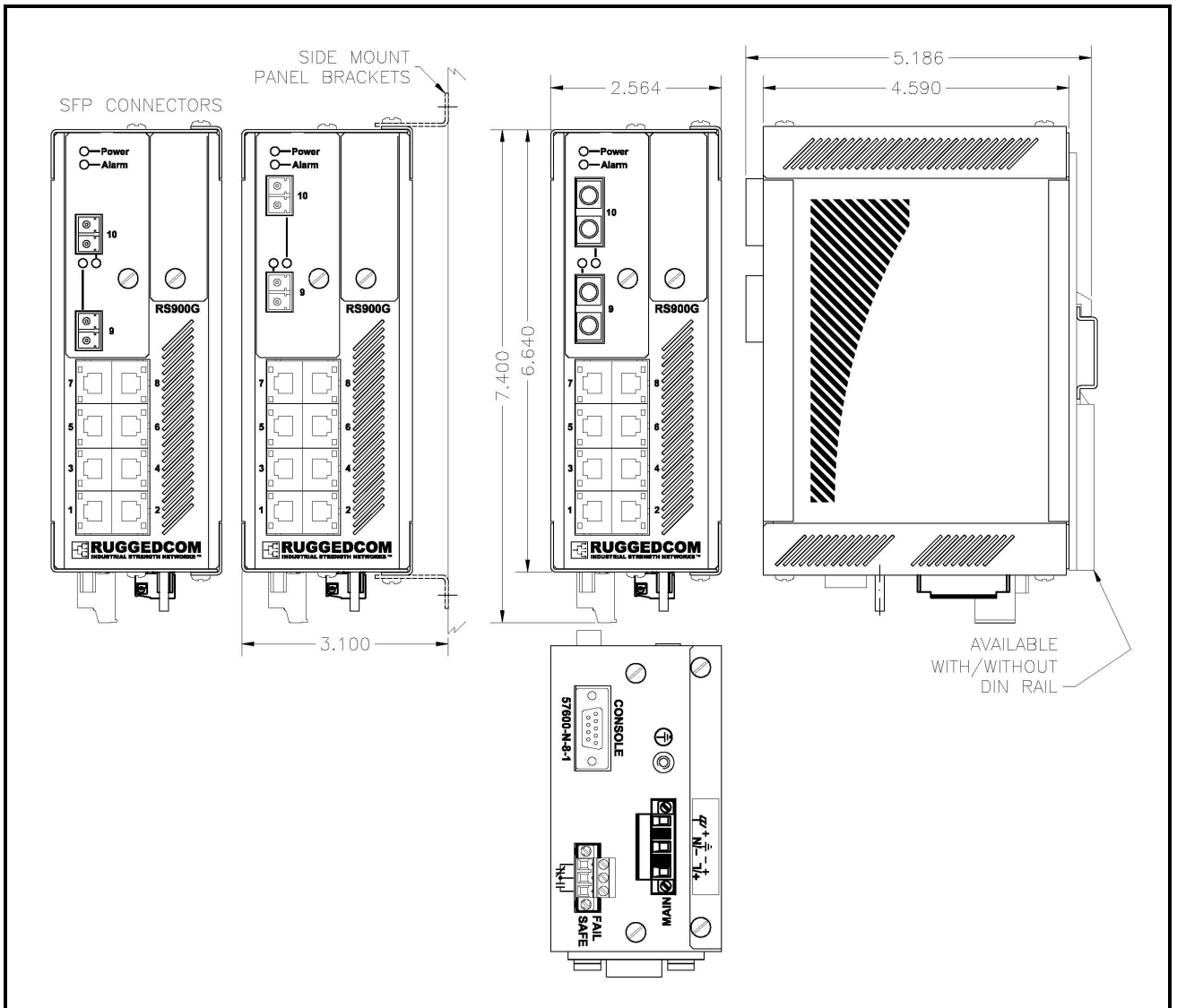

Parameter	Value	Comments
Dimensions	7,4 x 2,6 x 5,0 inches (187,96) x (66,04) x (127,0) mm	(Length x Width x Depth)
Weight	2.7 lb (1.2 Kg)	
Enclosure	20 AWG Galvanized Steel	

3.7 Agency Approvals

Agency	Standards	Comments
CSA	CSA C22.2 No. 60950, UL 60950	Approved
CE	EN 60950, EN 61000-6-2	CE Compliance is claimed via Declaration of Self Conformity Route
FCC	FCC Part 15, Class A	Approved
CISPR	EN55022, Class A	Approved
FDA/CDRH	21 CFR Chapter 1, Subchapter J	Approved
IEC/EN	EN60825-1:1994 + A11:1996 + A2:2001	Approved
CSA	Hazardous Locations Class 1, Division 2, Groups A, B, C, & D. T6 rating at 40°C, T4A rating at 85°C	Approved

4 Warranty

RuggedCom warrants this product for a period of five (5) years from date of purchase. For warranty details, visit <http://www.ruggedcom.com> or contact your customer service representative. Should this product require warranty or service contact the factory at:

RuggedCom Inc.
30 Whitmore Road,
Woodbridge, Ontario
Canada L4L 7Z4

Phone: (905) 856-5288
Fax: (905) 856-1995

Free Manuals Download Website

<http://myh66.com>

<http://usermanuals.us>

<http://www.somanuals.com>

<http://www.4manuals.cc>

<http://www.manual-lib.com>

<http://www.404manual.com>

<http://www.luxmanual.com>

<http://aubethermostatmanual.com>

Golf course search by state

<http://golfingnear.com>

Email search by domain

<http://emailbydomain.com>

Auto manuals search

<http://auto.somanuals.com>

TV manuals search

<http://tv.somanuals.com>