

RuggedSwitch™ RSG2200

9-Port Modular Managed Gigabit Ethernet Switch



Installation Guide

www.ruggedcom.com

RuggedCom Inc. | 30 Whitmore Road, Woodbridge, Ontario, Canada L4L 7Z4
Tel: (905) 856-5288 | **Fax:** (905) 856-1995 | **Toll Free:** (888) 264-0006

Federal Communications Commission Radio Frequency Interference Statement

This equipment has been tested and found to comply with the limits for a Class A digital device pursuant to Part 15 of the FCC Rules. These limits are designed to provide reasonable protection against harmful interference when the equipment is operated in a commercial environment. This equipment generates, uses and can radiate radio frequency energy and, if not installed and used in accordance with the instruction manual, may cause harmful interference to radio communications. Operation of this equipment in a residential area is likely to cause harmful interference in which case the user will be required to correct the interference on his own expense.

CAUTION

This product contains a laser system and is classified as a “**CLASS 1 LASER PRODUCT**”

CAUTION

Use of controls or adjustments or performance of procedures other than those specified herein may result in hazardous radiation exposure. This product contains no user serviceable parts. Attempted service by unauthorized personnel shall render all warranties null and void.

Changes or modifications not expressly approved by RuggedCom Inc. could void the user's authority to operate the equipment.

Should this device require service see the “Warranty and Service” section of this guide.

IMPORTANT

The RX1000 family of products should be installed in a **restricted access location** where access can only be gained by service personnel or users who have been instructed about the reasons for the restrictions applied to the location and about any precautions that shall be taken; and access is through the use of a tool or lock and key, or other means of security, and is controlled by the authority responsible for the location.

Trademarks:

Ethernet is a trademark of Xerox Corporation

RuggedRouter and RuggedRated, are trademarks of RuggedCom® Inc.

Table of Contents

1	Table of Figures	4
2	Table of Tables.....	4
3	Product Overview	5
3.1	Functional Overview.....	5
3.2	Feature Highlights.....	6
3.3	Mounting Flexibility	8
3.4	Ethernet Panel Description	9
3.4.1	Fiber Optical Transceiver Orientation and Connection	10
3.5	Display Panel Description.....	11
4	Installation	13
4.1	Rack Mounting.....	13
4.2	Panel and DIN Rail Mounting	14
4.3	Power Supply Wiring and Grounding.....	15
4.3.1	AC Power Supply Wiring Examples	17
4.3.2	DC Power Supply Wiring Examples	18
4.3.3	Dual Power Supplies – DC and AC Inputs.....	19
4.4	Dielectric Strength (HIPOT) Testing.....	20
4.5	Failsafe Alarm Relay Wiring and Specifications.....	21
4.6	Console Port Wiring	22
4.7	Gigabit Ethernet 1000Base-TX Cabling Recommendations	23
4.8	Pluggable optics – Installation, removal, and precautions.....	24
4.8.1	Module Insertion – GBICs and SFPs.....	24
4.8.2	GBIC Module Removal	25
4.8.3	SFP Module Removal	25
5	Technical Specifications.....	26
5.1	Power Supply Specifications	26
5.2	Failsafe Relay Specifications.....	26
5.3	Networking Standards Supported	26
5.4	Twisted-Pair Port Specifications.....	27
5.5	Fiber Optical Specifications.....	28
5.5.1	Gigabit Ethernet (1000Mbps) Modules	28
5.6	Type Test Specifications.....	30
5.7	Operating Environment.....	31
5.8	Mechanical Specifications	32
6	Agency Approvals	33
7	Warranty.....	33

1 Table of Figures

Figure 1: RSG2000 Rack mount chassis orientation options – Front and rear mount.....	8
Figure 2: Ethernet, LED Status, and Power Panels	9
Figure 3: Ethernet panel LED description.....	9
Figure 4: 1000LX SFP (mini-GBIC) Module and LC connector	10
Figure 5: 1000LX GBIC connector	10
Figure 6: 1000LX LC connector	10
Figure 7: 1000LX SC connector	10
Figure 8: 1000LX ST connector	11
Figure 9: RSG2200 LED Display Panel	11
Figure 10: RSG2000 Family 19" Rack Mount Adapters	13
Figure 11: Rack mount adapter mounting location.....	13
Figure 12: RSG2200 PANEL/DIN RAIL mounting diagram with.....	14
Figure 13: RSG2000 Series Philips Screw Terminal Block	15
Figure 14: RSG2000 Series Phoenix Plug Terminal Block.....	15
Figure 15: AC Power supply wiring examples	17
Figure 16: DC Power supply wiring examples.....	18
Figure 17: DC And AC power supply wiring examples.....	19
Figure 18: Dielectric Strength (HIPOT) Testing.....	20
Figure 19: Failsafe Alarm Relay Wiring	21
Figure 20: Console port location on display board	22
Figure 21: RSG2200 Console cable.....	22
Figure 22: SFP Orientation for top row and bottom row ports	24
Figure 23: Locking latch location on GBIC optical modules	25
Figure 24: SFP Bail Latch location	25
Figure 25: SFP Removal.....	25
Figure 26: RSG2200 Series mechanical dimensions	32

2 Table of Tables

Table 1: LED Display – Device status LED behavior definition	12
Table 2: Port Status behavior definition	12
Table 3: RSG2200 Power terminal block connection description.....	16
Table 4: RS232 over RJ45 console cable pin-out.....	22
Table 5: Cabling categories and 1000BaseTx compliance defined.....	23
Table 6: Gigabit port optical specifications.....	28

3 Product Overview

3.1 Functional Overview

The RuggedSwitch™ RSG2200 is an industrially hardened, fully managed, modular, Ethernet switch specifically designed to operate reliably in electrically harsh and climatically demanding utility substation and industrial environments. The RSG2200's superior ruggedized hardware design coupled with the RuggedSwitch™ Operating System (ROS) provides improved system reliability and advanced networking features making it ideally suited for creating Ethernet networks for mission-critical, real-time, control applications.

The RSG2200's modular flexibility offers 1000BaseX fiber and 10/100/1000BaseTX copper port combinations. Optional front or rear mount connectors make the RSG2200 highly versatile for any application and can support multiple fiber connectors (SFP, GBIC, LC, SC) without loss of port density. The RSG2200 is packaged in a rugged galvanized steel enclosure with industrial grade DIN, panel, or 19" rack mount mounting options.

3.2 Feature Highlights

Ethernet Ports

- 9-Gigabit Ethernet ports supporting copper and fiber media
- 2 port modules for tremendous flexibility
- Multimode and singlemode fiber support
- Bi - directional singlestrand fiber support
- Full compliance with IEEE: 802.3, 802.3u & 802.3z
- Non-blocking, store and forward switching
- Full duplex operation and flow control (IEEE 802.3x)
- Industry standard fiber optical connectors: LC, SC, SFP, GBIC
- Long haul optics allow Gigabit distances up to 70km

RuggedRated™ for Reliability in Harsh Environments

- Meets IEEE 1613 (electric utility substations)
- Exceeds IEC 61850-3 (electric utility substations)
- Exceeds IEEE 61800-3 (variable speed drive systems)
- Exceeds IEC 61000-6-2 (generic industrial environment)
- Exceeds NEMA TS-2 (traffic control equipment)
- -40 to +85°C operating temperature (no fans)
- Conformal coated printed circuit boards (optional)
- 18 AWG galvanized steel enclosure

Universal Power Supply Options

- Fully integrated, dual-redundant (optional) power supplies
- Universal high-voltage range: 88-300VDC or 85-264VAC
- Popular low voltage DC ranges: 12, 24 or 48 VDC
- Terminal blocks for reliable maintenance free connections
- CSA/UL 60950 safety approved to +85°C

Simple Plug and Play Operation

- Automatic learning of up to 8192 MAC addresses
- Auto-negotiation on all 10/100/1000BaseTX ports
- Auto-MDI/MDIX (crossover) on all 10/100BaseTX ports
- LED indicators for link, activity and speed

Rugged Operating System (ROS™) Advanced Network Management

- Enhanced Rapid Spanning Tree (eRSTP™)
- Quality of Service (802.1p) for real-time traffic
- Port rate limiting: 128kbps - 8Mbps
- VLAN (802.1q) with double tagging
- IGMP Snooping for multicast filtering
- Port configuration, status, statistics, mirroring, security
- Loss of link management on fiber ports
- Web-based, Telnet, CLI management interfaces
- SNMP v2 and RMON
- Rich set of diagnostics with logging and alarms

3.3 Mounting Flexibility

The RSG2000 series of products have been designed with maximum mounting and display flexibility. Customers can order an RSG2000 series switch that can be mounted in a standard 19" rack, 1" DIN Rail, or directly onto a panel. For rack mount installations, the RSG2000 series can be ordered with connectors on the front of the unit, or can be located on the rear of the chassis to allow for all data and power cabling to be installed and connected at the rear of the rack. See Figure 1 for rack mount orientation examples.

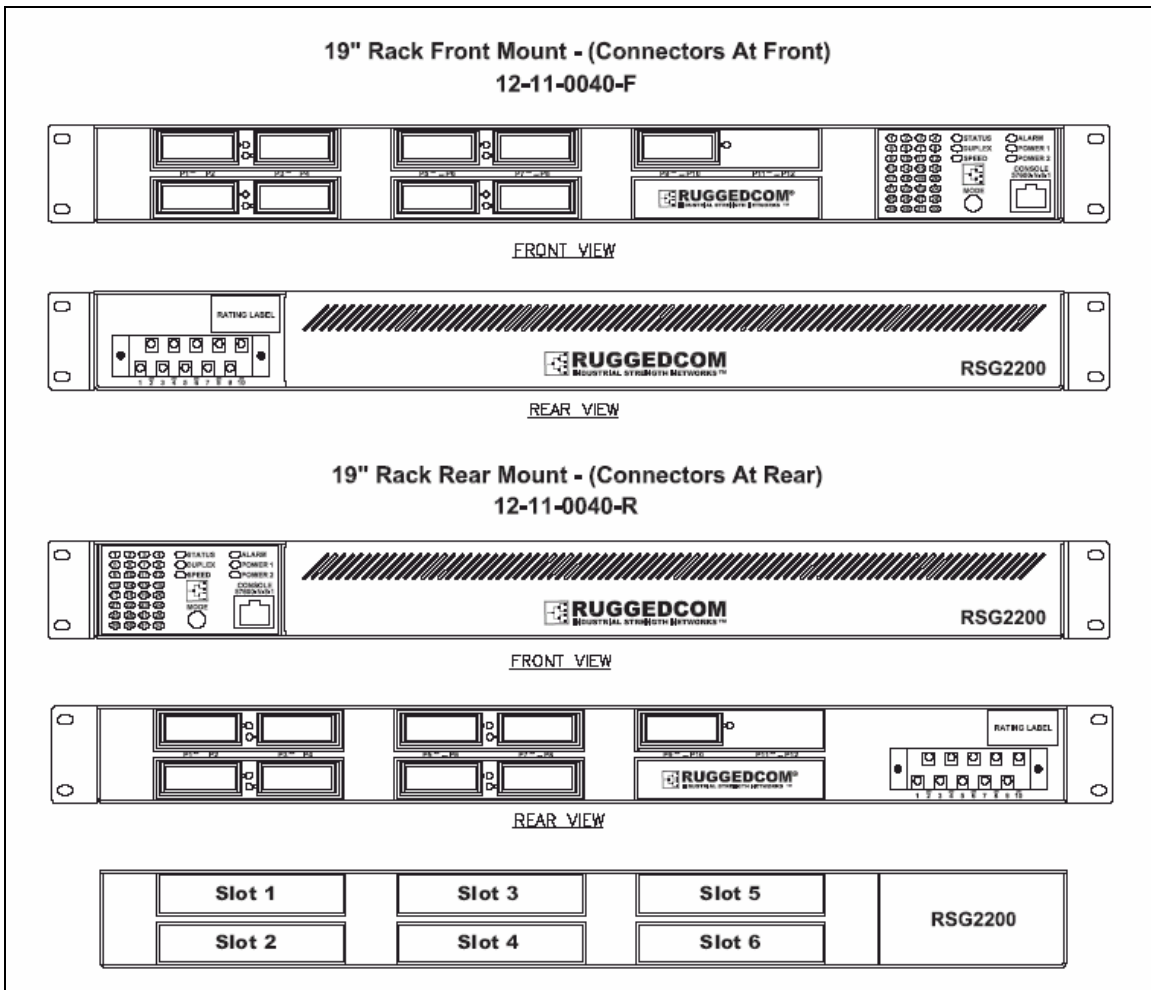

Figure 1: RSG2000 Rack mount chassis orientation options – Front and rear mount.

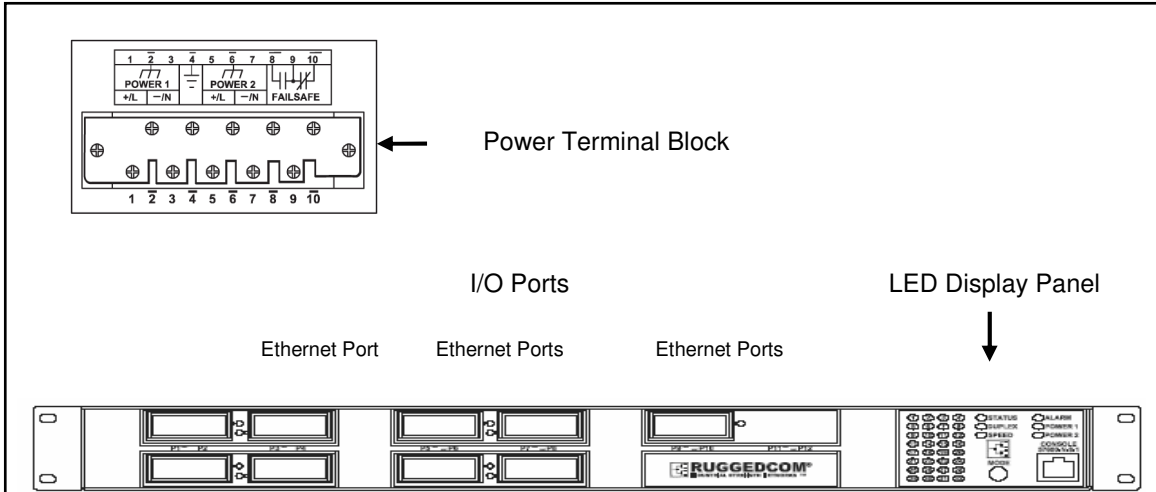

Figure 2: Ethernet, LED Status, and Power Panels

3.4 Ethernet Panel Description

Each Ethernet module is equipped with two LEDs that indicate link/activity status information. The LED will be solid for ports with link, and will blink for activity. The diagram in Figure 3 highlights the port and the associated link/activity LED.

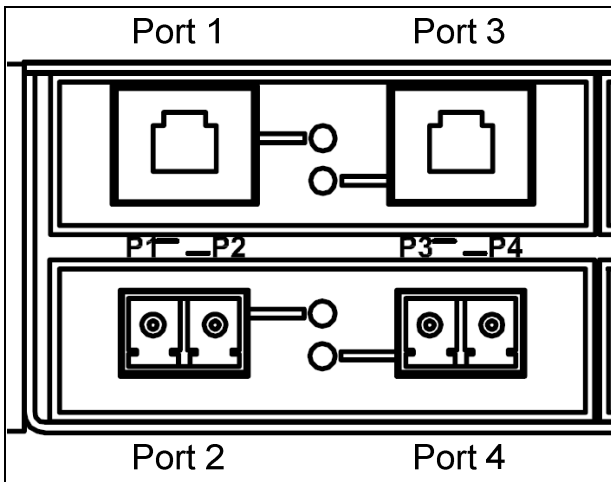

Figure 3: Ethernet panel LED description

3.4.1 Fiber Optical Transceiver Orientation and Connection

Depending on the order code of the product, the RSG2000 series products can be equipped with several different types of fiber optic ports. The Transmit (TX) and Receive (RX) connections of each port must be properly connected and matched for proper link and operation. Modules populated on the top row of the device typically have locking mechanisms or tabs towards the top of the unit. Modules located on the bottom row of the device have locking mechanisms or tabs towards the bottom of the device.

The drawings in the following figures show each fiber optical connector style with a side and top view to allow the user to identify the proper cable connection orientation. If modules are populated on the bottom row of the device, the transceiver orientation will be reversed (ie RX and TX will be reversed).

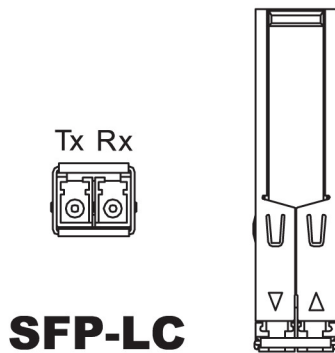

Figure 4: 1000LX SFP (mini-GBIC) Module and LC connector

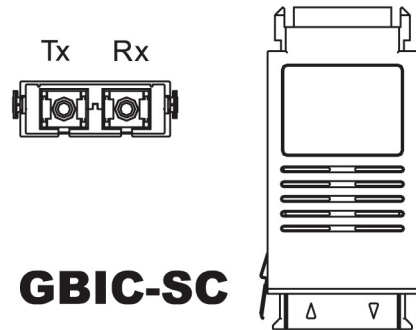

Figure 5: 1000LX GBIC connector

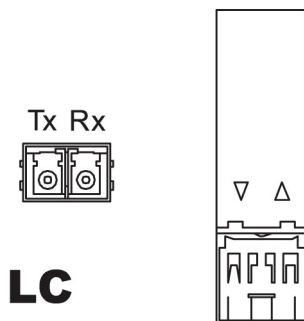

Figure 6: 1000LX LC connector

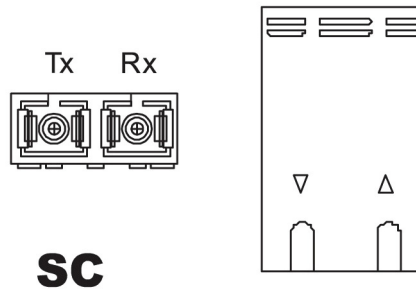

Figure 7: 1000LX SC connector

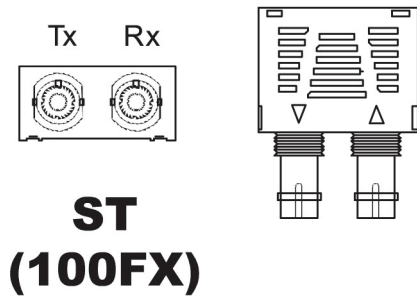

Figure 8: 1000LX ST connector

3.5 Display Panel Description

The RSG2000 series products are equipped with a versatile display panel, shown in Figure 9, which is designed to provide quick status information for each port, as well as the entire device to allow for simple diagnostics and troubleshooting. It features:

- RS232 console port for 'out of band' console access and configuration
- Power supply and Alarm status indicators
- Convenient port status indicators conveying Link-Activity, Duplex, or Speed via push-button control.
- System reset via push-button if held for 5 seconds

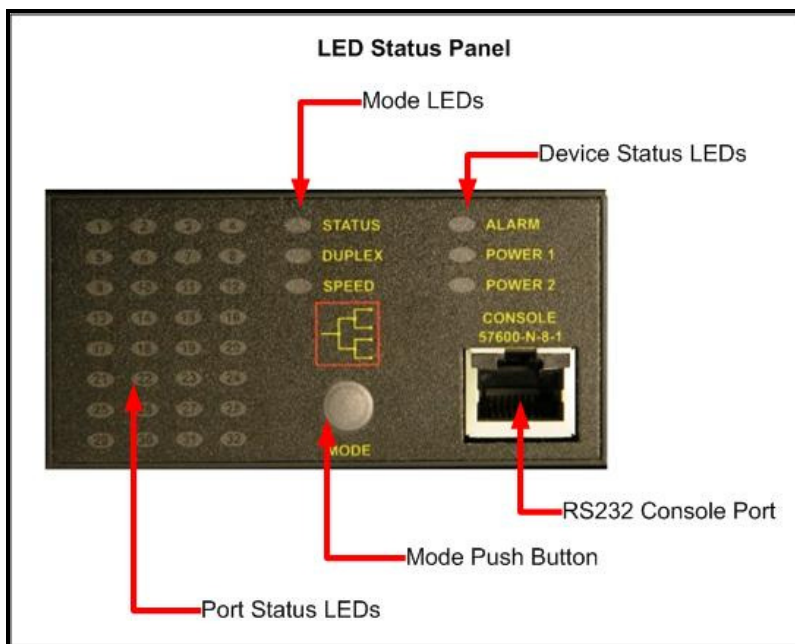

Figure 9: RSG2000 LED Display Panel

Device status LEDs exist to provide a quick visual indicator to operators for operational status of the unit. Table 1 defines the possible LED colours and the corresponding description.

LED	Colour	Description
PS1 / PS2	Green	Power supply operating normal
	Red	Power supply failure
	Off	No power supply installed
Alarm	Red	Alarm exist – login to web management interface to determine alarm code
	Off	No alarms exist

Table 1: LED Display – Device status LED behavior definition

The port-based LEDs can be cycled between three display modes: Status, Duplex, and Speed. Pushing the mode button causes the display mode to be cycled.

Mode	Colour	Description
Status	Green (Solid)	Link
	Green (Blinking)	Activity
	Off	No link
Duplex	Green (Solid)	Full-Duplex operation
	Orange (Solid)	Half-Duplex operation
	Off	No link
Speed	Green (Blinking)	1000Mb/s
	Green (Solid)	100Mb/s
	Orange (Solid)	10Mb/s
	Off	No link

Table 2 defines the possible port LED colours and the corresponding description.

Mode	Colour	Description
Status	Green (Solid)	Link
	Green (Blinking)	Activity
	Off	No link
Duplex	Green (Solid)	Full-Duplex operation
	Orange (Solid)	Half-Duplex operation
	Off	No link
Speed	Green (Blinking)	1000Mb/s
	Green (Solid)	100Mb/s
	Orange (Solid)	10Mb/s
	Off	No link

Table 2: Port Status behavior definition

4 Installation

4.1 Rack Mounting

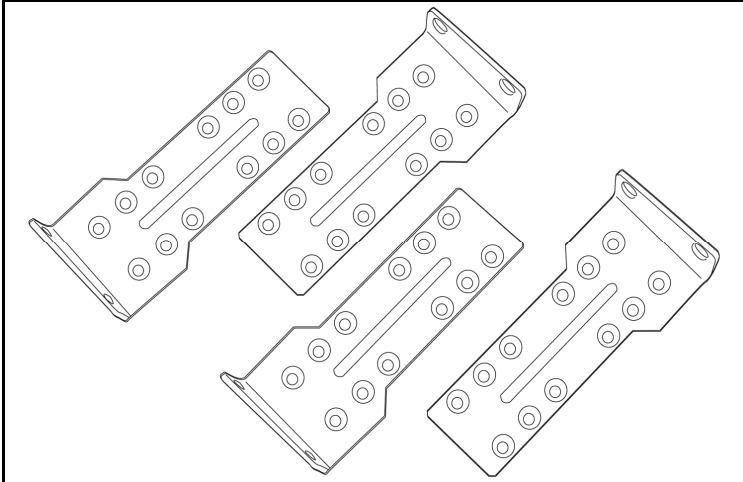

Figure 10: RSG2000 Family 19" Rack Mount Adapters

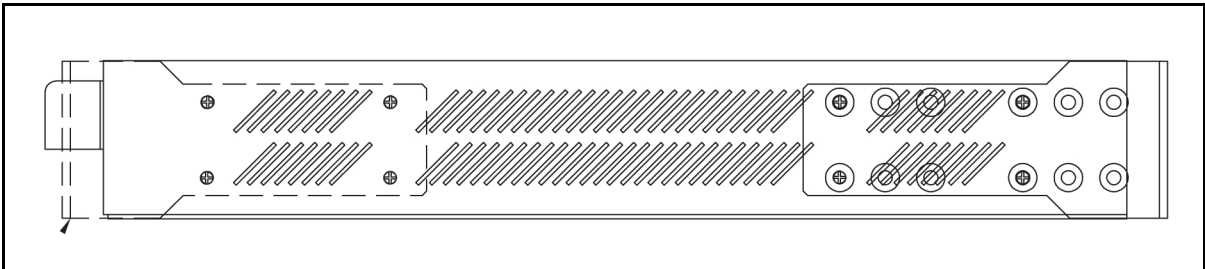

Figure 11: Rack mount adapter mounting location

The RSG2000 family of products can be rack mounted using the included rack mount adapter assemblies shown in Figure 10. Secure the rack mount adapter to the front side of the chassis using the included black PAN head Philips screws in the positions shown in Figure 12. The entire chassis can then be mounted to a standard 19" rack. An additional two rack mount adapters are included to optionally secure the rear of the chassis in high-vibration, or seismically active locations.

Note: Since heat within the RS2000 is channeled to the enclosure, it is recommended that 1 rack-unit of space (1.75") be kept unpopulated and free of equipment above each RS2000 series product to allow for a small amount of convective airflow. Although forced airflow is not necessary, any increase in airflow will result in a reduction of ambient temperature that will improve long-term reliability of all equipment mounted within the rack space.

4.2 Panel and DIN Rail Mounting

The RSG2200 series products can be ordered as a Panel/DIN mount chassis. Both options involve the use of the panel/DIN adapters to be mounted on each side of the chassis enclosure. The adapter allows for the chassis to be mounted on the standard 1" DIN rail using the grooves in the adapter, secured using the included Philips screw. See Figure 12 for a PANEL/DIN mount diagram.

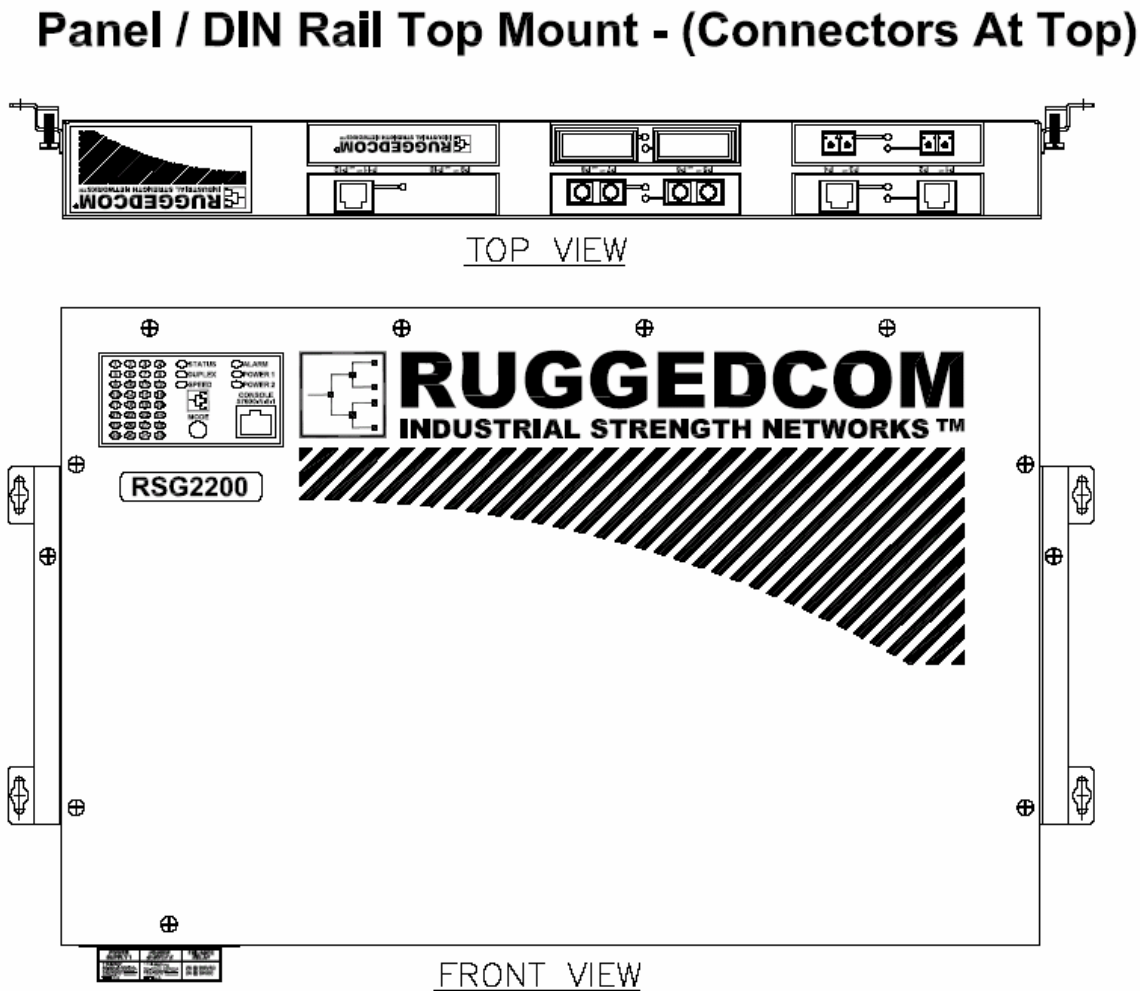

Figure 12: RSG2200 PANEL/DIN RAIL mounting diagram with

4.3 Power Supply Wiring and Grounding

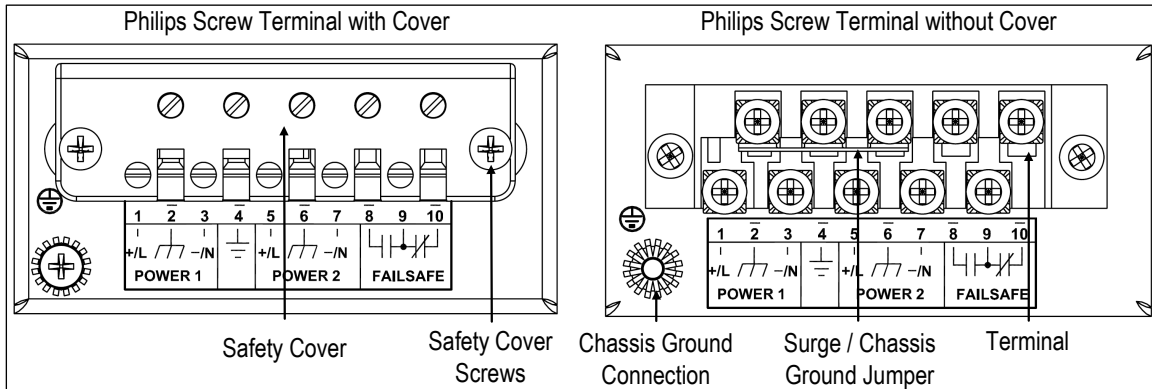

Figure 13: RSG2000 Series Philips Screw Terminal Block

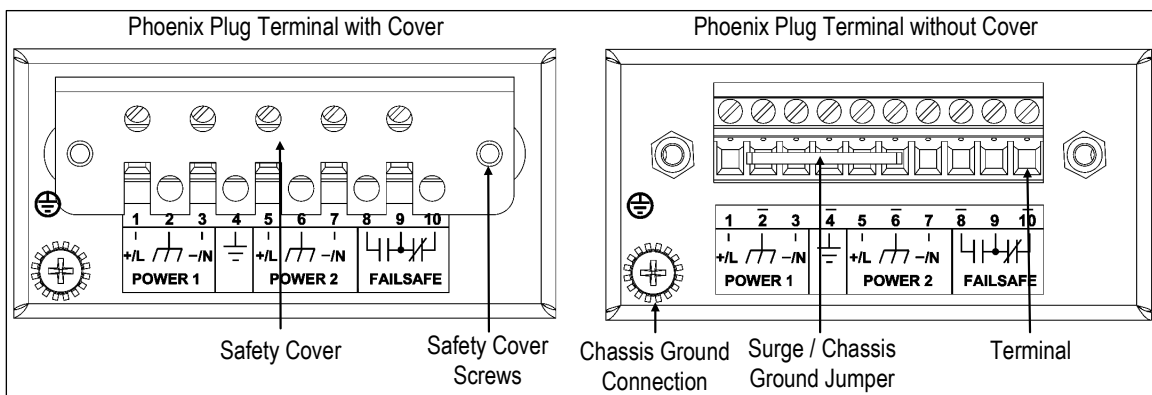

Figure 14: RSG2000 Series Phoenix Plug Terminal Block

The RSG2200 family supports dual redundant power supplies – “Power Supply 1 (PS1)” and “Power Supply 2 (PS2)”. The connections for PS1, PS2 and the fail-safe relay are located on the terminal block as shown in Figure 13 and Figure 14.

The RSG2200 family can be equipped with either a Philips Screw Terminal Block or a Phoenix Plug Terminal Block. The Philips Screw Terminal Block has Philips screws with a compression plate allowing either bare wire connections or crimped terminal lugs. We recommend the use of #6 size ring lugs to ensure secure, reliable connections under severe shock or vibration. Both terminal blocks have a safety cover which must be removed via two Phillips screws before connecting any wires. The safety cover must be re-attached after wiring to ensure personnel safety. Refer to Table 3 below for a description of each terminal as well as sections 4.3.1 through 4.3.3 for wiring examples.

Terminal #	Description	Usage
1	PS1 Live / +	PS1 Live / + is connected to the positive (+) terminal if the power source is DC or to the (Live) terminal if the power source is AC.
2	PS1 Surge Ground	PS1 Surge Ground is connected to the Chassis Ground via a jumper on the terminal block. Surge Ground is used as the ground conductor for all surge and transient suppression circuitry. NOTE: Surge Ground must be disconnected from Chassis Ground during HIPOT (dielectric strength) testing.
3	PS1 Neutral / -	PS1 Neutral / - is connected to the negative (-) terminal if the power source is DC or to the (Neutral) terminal if the power source is AC.
4	Chassis Ground	Chassis Ground is connected to the Safety Ground terminal for AC inputs or the equipment <i>ground bus</i> for DC inputs. Chassis ground connects to both power supply surge grounds via a removable jumper.
5	PS2 Live / +	PS2 Live / + is connected to the positive (+) terminal if the power source is DC or to the (Live) terminal if the power source is AC.
6	PS2 Surge Ground	PS2 Surge Ground is connected to the Chassis Ground via a jumper on the terminal block. Surge Ground is used as the ground conductor for all surge and transient suppression circuitry. NOTE: Surge Ground must be disconnected from Chassis Ground during HIPOT (dielectric strength) testing.
7	PS2 Neutral / -	PS2 Neutral / - is connected to the negative (-) terminal if the power source is DC or to the (Neutral) terminal if the power source is AC.
8	Relay NO Contact	Normally open, failsafe relay contact.
9	Relay Common	Failsafe relay common contact.
10	Relay NC Contact	Normally closed, failsafe relay contact.

Table 3: RSG2200 Power terminal block connection description

4.3.1 AC Power Supply Wiring Examples

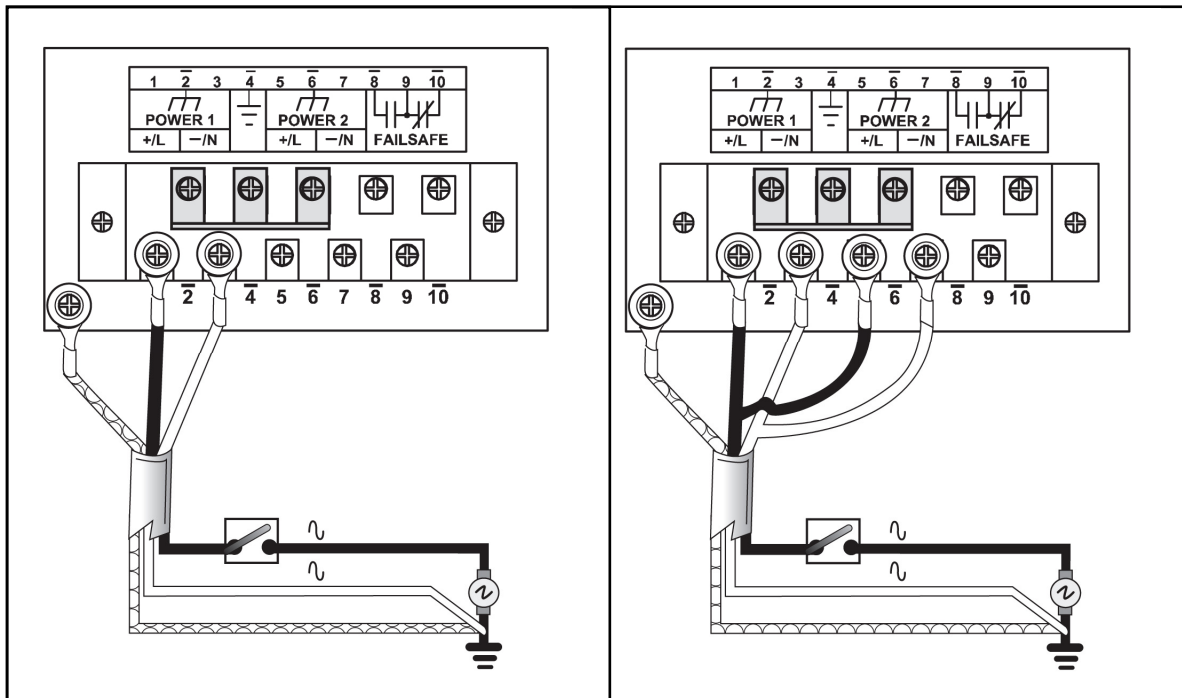

Figure 15: AC Power supply wiring examples

Notes:

1. **100-240VAC rated equipment:** A 250VAC appropriately rated circuit breaker must be installed within 3m of unit.
2. **Equipment must be installed according to the applicable country wiring codes.**
3. **When equipped with two HI voltage power supplies, independent AC sources can be used to power the product for greater redundancy.**

4.3.2 DC Power Supply Wiring Examples

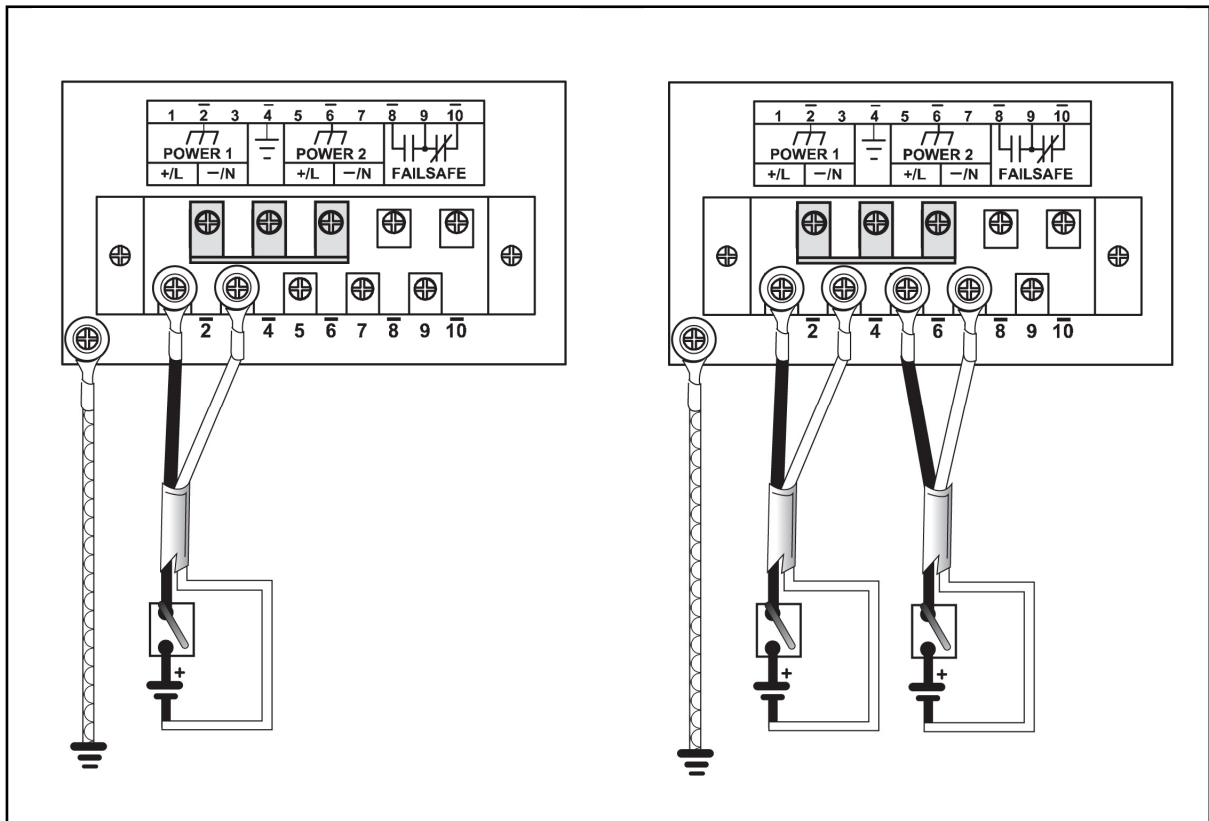

Figure 16: DC Power supply wiring examples

Notes:

1. **88-300VDC rated equipment: A 300VDC appropriately rated circuit breaker must be installed within 3m of unit.**
2. **A circuit breaker is not required for 12, 24 or 48 VDC rated power supplies.**
3. **For dual DC power supplies, Separate circuit breakers must be installed and separately identified.**
4. **Equipment must be installed according to the applicable country wiring codes.**

4.3.3 Dual Power Supplies – DC and AC Inputs

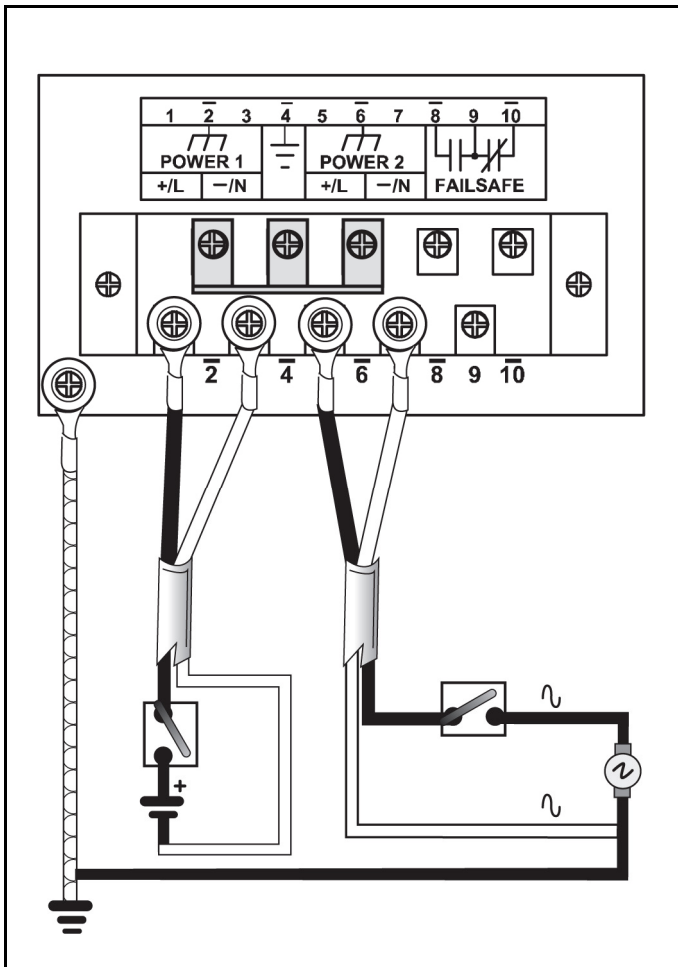

Figure 17: DC And AC power supply wiring examples

Notes:

1. **88-300VDC rated equipment:** A 300VDC appropriately rated circuit breaker must be installed within 3m of unit.
2. **100-240VAC rated equipment:** A 250VAC appropriately rated circuit breaker must be installed within 3m of unit.
3. A circuit breaker is not required for 48 or 24VDC rated power supplies.
4. Separate circuit breakers must be installed and separately identified.
5. Equipment must be installed according to the applicable country wiring codes.

4.4 Dielectric Strength (HIPOT) Testing

For dielectric strength (HIPOT) testing in the field, users must remove the metal jumper located on terminal 2, 4, and 6 of the power supply terminal block. This metal jumper connects transient suppression circuitry to chassis ground and must be removed in order to avoid damage to transient suppression circuitry during HIPOT testing. Figure 18 shows the proper HIPOT test connections and should be followed to avoid damage to the device.

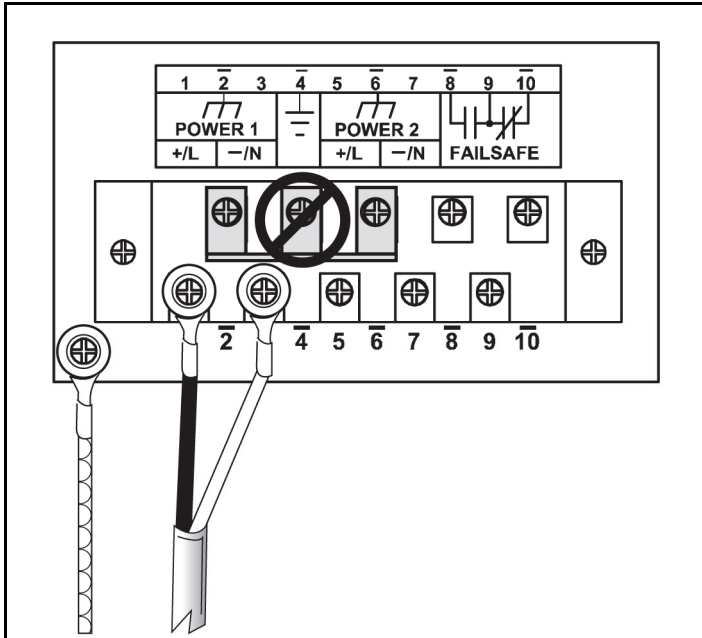

Figure 18: Dielectric Strength (HIPOT) Testing

4.5 Failsafe Alarm Relay Wiring and Specifications

The “Failsafe” output relay is provided to signal critical error conditions that may occur on the RSG2200 series products. The contacts are energized upon power up of the unit and remain energized until a critical error occurs. The proper relay connections are shown in Figure 19. One common application for this output is to signal an alarm if a power failure or removal of control power occurs.

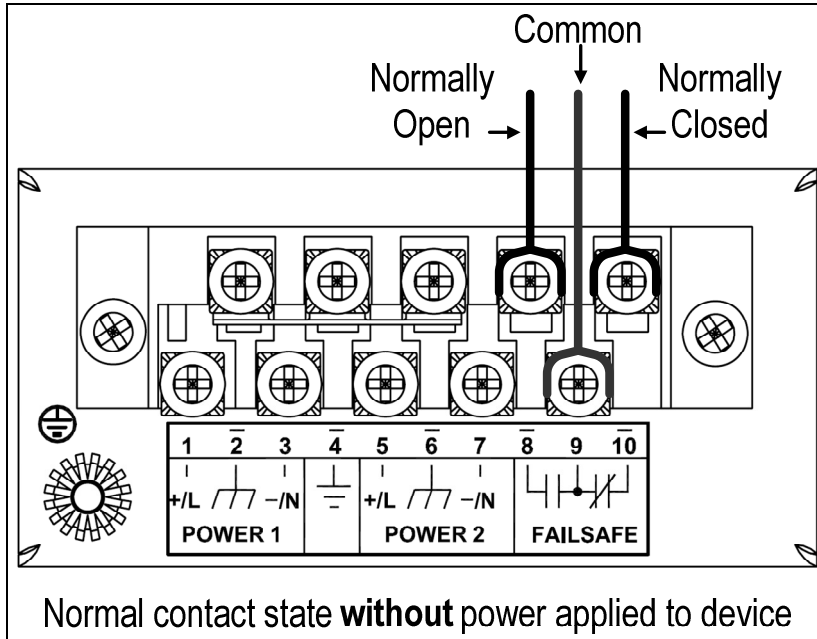

Figure 19: Failsafe Alarm Relay Wiring

4.6 Console Port Wiring

A RS232 console port for configuration and management of the device is located on the LED display module shown in Figure 20. This port is intended to be a temporary connection during initial configuration or troubleshooting and allows for direct access to the serial-based management console. The connection is made using the DB9-Female to RJ45 console cable included in the device packaging shown in Figure 21. Console connection settings are: 57600 baud, no parity bits, 8 data bits, and 1 stop bit.

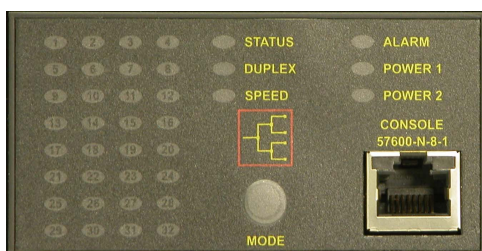

Figure 20: Console port location on display board

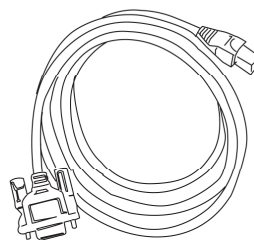

Figure 21: RSG2200 Console cable

For user reference, the console cable pin-out is shown in Table 5.

RuggedCom RS232 over RJ45 pin-out specification		
<i>Signal Name (PC is DTE)</i>	<i>DB9- Female</i>	<i>RJ45 Male</i>
DCD – Carrier detect	1	2
RxD – Receive data (to DTE)	2	5
TxD – Transmit data (from DTE)	3	6
DTR – Data terminal ready	4	3
Signal GND	5	4
DSR – Data set ready	6	1*
RTS – Ready to send	7	8
CTS – Clear to send	8	7
RI – Ring Indicator	9	1*

Table 4: RS232 over RJ45 console cable pin-out

After initial configuration, the RuggedRouter device can be configured via a number of new mechanisms such as Telnet, and the built-in web server. Consult the RuggedRouter ROS User Guide for further details.

NOTE: This port is not intended to be a permanent connection and the cable shall be less than 2m (6.5 ft) in length.

4.7 Gigabit Ethernet 1000Base-TX Cabling Recommendations

The IEEE 802.3ab Gigabit Ethernet standard defines 1000 Mbit/s Ethernet communications over distances of up to 100 meters using 4 pairs of category 5 (or higher) balanced unshielded twisted-pair cabling. For wiring guidelines, system designers and integrators should refer to the Telecommunications Industry Association (TIA) TIA/EIA-568-A wiring standard that characterizes minimum cabling performance specifications required for proper Gigabit Ethernet operation. To ensure reliable, error-free data communications, new and pre-existing communication paths should be verified for TIA/EIA-568-A compliance. Table 5 summarizes cabling standards available today

Cabling Category	1000BaseTx Compliant	Required action
< 5	No	New wire infrastructure required
5	Yes	Verify TIA/EIA-568-A compliance
5e	Yes	No action required. New installations should be designed with Category 5e components or higher
6	Yes	No action required
> 6	Yes	Connector and cabling standards to be determined.

Table 5: Cabling categories and 1000BaseTx compliance defined.

In general the following recommendations should be followed for copper data cabling in high electrical noise environments:

- Data cable lengths should be as short as possible, ideally limited to 3m (10ft) in length. Copper data cables should not be used for inter-building communications.
- Power and data cables should not be run in parallel for long distances, and ideally should be installed in separate conduits. Power and data cables should intersect at 90° angles when necessary to reduce inductive coupling.
- Shielded/screened cabling can optionally be used. The cable shield should be grounded at one single point to avoid the generation of ground loops.

NOTE: RuggedCom does not recommend the use of copper cabling of any length for critical real-time substation automation applications. However, transient suppression circuitry is present on all copper ports to protect against damage from electrical transients and to ensure IEC 61850-3 and IEEE 1613 Class 1 conformance. This means that during the transient event communications errors or interruptions may occur but recovery is automatic. RuggedCom also does not recommend to use these ports to interface to field devices across distances which could produce high levels of ground potential rise, (i.e. greater than 2500V) during line to ground fault conditions.

4.8 Pluggable optics – Installation, removal, and precautions

The RSG2000 series of products can be ordered with pluggable optic form factors such as SFP (Small Form-factor Pluggable) or GBIC (Gigabit Interface Converter) modules. These modules can be safely inserted and removed while the chassis is powered and operating – this feature is also known as “hot-swappable”. When inserting or removing optics there are several precautions that should be taken. They include:

- Ensuring that dust caps are mounted on SFP cages at all times unless a user is in the process of inserting or removing an SFP module. The dust caps will prevent the accumulation of residue or particles that may inhibit proper operation.
- Ensuring that the user has properly discharged any possible electrostatic build-up and electrostatic discharges (ESD). This can be accomplished by properly user ‘grounding’ via an ESD wrist strap, or by touching earth or chassis ground before performing installation or removal of optics. ESD can damage or shorten the life of optical modules when not plugged into a chassis.
- SFP and GBIC optical modules should always be stored in an ESD safe bag or other suitable ESD safe environment, free from moisture and stored at proper storage temperature (–40 to +85°C).
- Disconnect all cables from SFP or GBIC module before insertion or removal of module.
- Only RuggedCom Inc. certified optics should be used on RuggedCom products. Damage can occur to optics and product if compatibility and reliability have not been properly assessed.

4.8.1 Module Insertion – GBICs and SFPs

To insert GBICs or SFPs, special attention should be taken into the proper module orientation. Refer to Figure 22 for proper module orientation, as ports on the upper row of the product require optics to be inserted topside-up, and ports on the lower row of the product require modules to be inserted topside-down. GBICs should be inserted with module dust cover in place. SFPs should be inserted with dust cover in place, and the bail-latch in the locked position. Module should gently slide into port and should lock in place when module is fully inserted. To protect optics, dust covers should always be installed when cables are not connected.

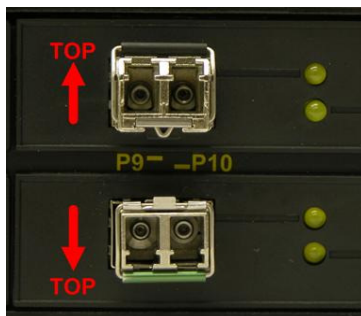

Figure 22: SFP Orientation for top row and bottom row ports

4.8.2 GBIC Module Removal

GBIC Modules have two locking latches on either side of the module shown in Figure 23. To remove GBIC module, disconnect any cable and replace with dust cover to protect the optics. User should depress both latches simultaneously and gently pull the module from the chassis. The module should be immediately stored in an ESD-safe environment.

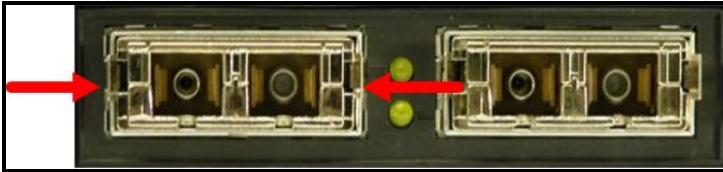

Figure 23: Locking latch location on GBIC optical modules

4.8.3 SFP Module Removal

SFP Modules are removed using the metal bail latch located on the top of the module shown in Figure 24. To remove the SFP module, disconnect any cable and replace with dust cover to protect the optics. User should grasp bail latch and gently pull outwards to unlock and remove the SFP module. Removal of the SFP module is shown further in Figure 25. The module should be immediately stored in an ESD-safe environment.



Figure 24: SFP Bail Latch location



Figure 25: SFP Removal

5 Technical Specifications

5.1 Power Supply Specifications

Power Supply Type	Input Range		Fuse Rating	Max. Power Consumption ³
	Min	Max		
12 – 24 VDC	10 VDC	36 VDC	6.3A(F) ²	22W
24 VDC	18 VDC	36 VDC	5A(F) ²	
48 VDC	36 VDC	59 VDC	2A(T) ²	
HI (125/250 VDC) ¹ HI (110/230 VAC) ¹	88 VDC 85 VAC	300 VDC 265 VAC	2A(T) ^{1,2}	

NOTES:

1. This is the same power supply for both AC and DC.
2. (F) Denotes fast-acting fuse, (T) denotes time-delay fuse
3. Power consumption varies based on configuration. 10/100Base-TX ports consume roughly 1W less than fiber optic ports
4. For continued protection against risk of fire, replace only with same type and rating of fuse.

5.2 Failsafe Relay Specifications

Parameter	Value (Resistive Load)
Max Switching Voltage	240VAC, 125VDC
Rated Switching Current	2A @ 240VAC 0.15A @ 125VDC, 2A @ 30VDC
Max Switching Capacity	150W, 500VA

5.3 Networking Standards Supported

Parameter	10Mbps Ports	100Mbps Ports	1000Mbps Ports	Notes
IEEE 802.3				10BaseT / 10BaseFL
IEEE 802.3u				100BaseTX / 100BaseFX
IEEE 802.3z			✓	1000BaseSX/LX
IEEE 802.3ab			✓	1000BaseTx
IEEE 802.3x	✓	✓	✓	Full Duplex Operation
IEEE 802.1D	✓	✓	✓	MAC Bridges
IEEE 802.1Q	✓	✓	✓	VLAN (Virtual LAN)
IEEE 802.1p	✓	✓	✓	Priority Levels

5.4 Twisted-Pair Port Specifications

Parameter	Specification	Notes
Speed	10/100 Mbps	Auto-negotiating
Duplex	FDX / HDX	Auto-negotiating
Cable-Type	> Category 5	Shielded/Unshielded
Wiring Standard	TIA/EIA T568A/B	Auto-Crossover, Auto-polarity
Max Distance	100m	
Connector	RJ45	
Isolation	1.5kV	RMS 1-minute

5.5 Fiber Optical Specifications

The following sections detail fiber optical specifications on ports that can be ordered with the RSG2200 series Ethernet switch. The user determines the type of optics at time of ordering, and can determine the modules installed on a particular unit by reading the factory data file via the RuggedSwitch ROST™ user interface. The following sections detail specifications of fiber optic modules in Gigabit Ethernet (1000Mbps).

5.5.1 Gigabit Ethernet (1000Mbps) Modules

For maximum flexibility RuggedCom Inc. offers a number of different transceiver choices for Gigabit fiber optical communications. Table 6 details fiber optic specifications based on the 2-port modules or pluggable transceivers selected at time of ordering.

Optics Order Code	Mode / Connector	Tx λ (nm)	Cable Type ² (μ m)	Tx Pwr (dBm) ³ (Min/Max)	Rx Sensitivity (dBm) ³	Rx Saturation (dBm) ³	Typical Distance (km) ¹	Power Budget (dB)
12-11-0036	MM / LC	850	50/125	-9.5 / -4	-20	0	0.5	13
12-11-0027	SM / LC	1310	9/125	-9.5 / -3	-22	-3	10	18.5
12-11-0028				-5 / 0	-22	-3	25	19.5
12-11-0025	SM / SC			-10 / -3	-22	-3	10	15.5
12-11-0026				-5 / 0	-20	-3	25	17.5
SFP Pluggable Optics								
25-10-0111	SFP MM / LC	850	50/125	-8.5 / -4	-22	-3	0.5	15.5
25-10-0100	SFP SM / LC	1310	9/125	-9 / -3	-24	0	10	19
25-10-0101		-7 / -3		-26	-3	25	21	
25-10-0108 ⁵		1550 ⁴		-5 / 0	-26	-3	40	23
25-10-0109 ⁴				0 / 5	-26	0	70	28
25-10-0202	SFP SM / SC	1310	Simplex 9/125	-9 / -3	-22	-3	10	16
25-10-0203 ⁴	SFP SM / SC	1490 ⁴	Simplex 9/125	-9 / -3	-22	-3	10	16
GBIC Pluggable Optics								
25-10-0102	GBIC SM / SC	1310	9/125	-9 / -3	-21	-3	10	15
25-10-0103		-3 / 2		-23	-3	40	23	
25-10-0105 ⁴		1550 ⁴		0 / 5	-23	-3	70	25.5

Table 6: Gigabit port optical specifications

Notes:

1. Maximum segment length is greatly dependent on factors such as fiber quality, and number of patches and splices. Please consult RuggedCom sales associates when determining maximum segment distances.

2. All cabling is duplex type unless otherwise specified.
3. All optical power numbers are listed as dBm averages.
4. These transceivers utilize a distributed feedback (DFB) type laser and are rated for -20°C to +85°C operation only.
5. The 25-10-0108 SFP module is obsolete, and has been replaced with the 70km 25-10-0109 SFP module.

5.6 Type Test Specifications

Electrical Safety	Levels	Comments
Dielectric Withstand	2 kV rms for 1 minute	ANSI/IEEE C37.90 (1989) IEC 60255-5 (Section 6)
High Voltage Impulse	5 kV peak	IEC 60255-5 (Section 8)
Insulation Resistance	500 VDC for 1 minute	IEC 60255-5 (Section 6)

Electrical Environment	Levels	Comments
High Frequency Disturbance (Oscillatory)	2.5 kV @ 1MHz for 2s	ANSI/IEEE C37.90.1 IEC 60255-22-1
IEC Surge	4 kV / 2 kV	IEC 61000-4-5 (Level 4)
IEC Fast Transient	2 kV / 1 kV	IEC 61000-4-4 (Level 4)
ANSI/IEEE Fast Transient	4 kV	ANSI/IEEE C37.90.1
IEC Radiated RFI Immunity	10 V/m	IEC 61000-4-3
ANSI/IEEE Radiated RFI Immunity	20 V/m	ANSI/IEEE C37.90.2
ESD (Electrostatic Discharge)	15 kV (air discharge) 8 kV (contact)	IEC 61000-4-2 (Level 4)

Atmospheric Environment	Levels	Comments
Temperature (Dry Cold)	-40°C	IEC 60068-2-1 Test Ad: 16 hrs @ -40°C
Temperature (Dry Heat)	85°C	IEC 60068-2-2 Test Bd: 16 hrs @ 85°C
Humidity	95% non-condensing	IEC 60068-2-30 Test Db: 6 cycles, 55°C, 95% Humidity

5.7 Operating Environment

Parameter	Range	Comments
Ambient Operating Temperature	-40 to 85°C	Ambient Temperature as measured from a 30cm radius surrounding the center of the RS1600 enclosure.
Ambient Relative Humidity	5% to 95%	Non-condensing
Ambient Storage Temperature	-40 to 85°C	

5.8 Mechanical Specifications

Parameter	Value	Comments
Dimensions	18.29 x 12.14 x 1.75 inches (464,57) x (308,356) x (44,45) mm	(Length x Width x Height) with mounting brackets installed
Weight	10 lb (4.5 Kg)	
Enclosure	18awg galvanized steel	

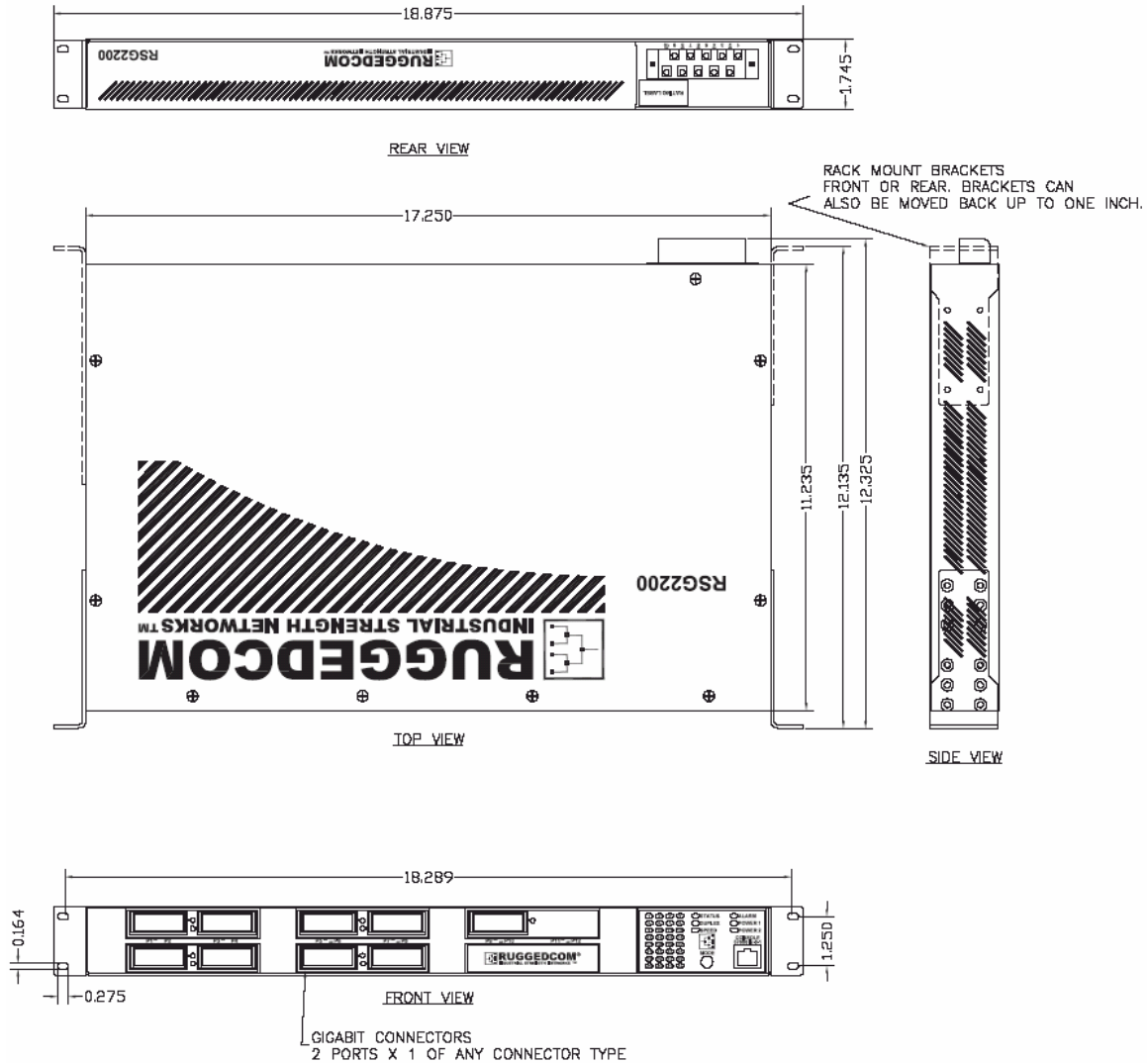

Figure 26: RSG2200 Series mechanical dimensions

6 Agency Approvals

Agency	Standards	Comments
CSA	CSA C22.2 No. 60950, UL 60950	Approved
CE	EN 60950, EN 61000-6-2	Approved
FCC	FCC Part 15, Class A	Approved
CISPR	EN55022, Class A	Approved
FDA/CDRH	21 CFR Chapter 1, Subchapter J	Compliant
IEC/EN	EN60825-1:1994 + A11:1996 + A2:2001	Compliant

7 Warranty

RuggedCom warrants this product for a period of five (5) years from date of purchase. For warranty details, visit <http://www.ruggedcom.com/> or contact your customer service representative.

Should this product require warranty or service contact the factory at:

RuggedCom Inc.
30 Whitmore Road
Woodbridge, Ontario
Canada L4L 7Z4
Phone: (905) 856-5288
Fax: (905) 856-1995

Free Manuals Download Website

<http://myh66.com>

<http://usermanuals.us>

<http://www.somanuals.com>

<http://www.4manuals.cc>

<http://www.manual-lib.com>

<http://www.404manual.com>

<http://www.luxmanual.com>

<http://aubethermostatmanual.com>

Golf course search by state

<http://golfingnear.com>

Email search by domain

<http://emailbydomain.com>

Auto manuals search

<http://auto.somanuals.com>

TV manuals search

<http://tv.somanuals.com>