

# RuggedMC™ RMC40

## Installation Guide

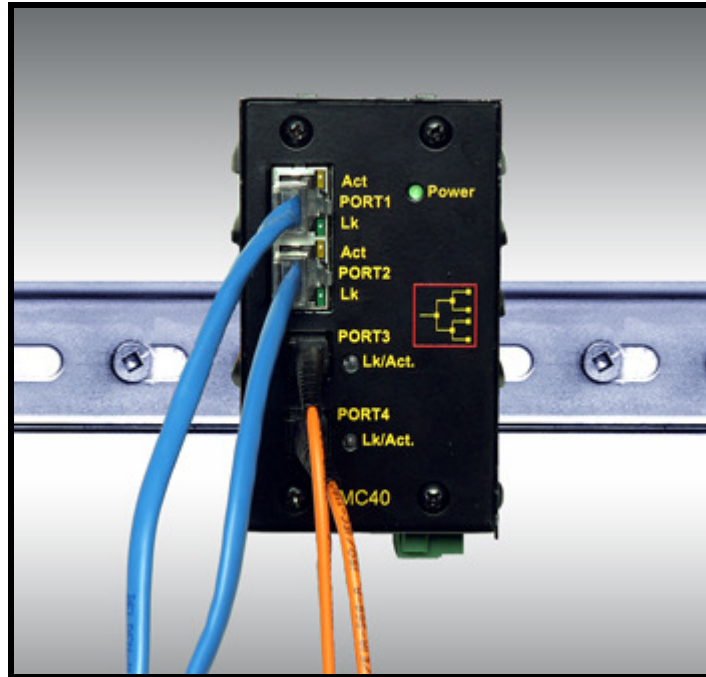

**RuggedCom Inc.**  
**30 Whitmore Road**  
**Woodbridge, Ontario**  
**Canada L4L 7Z4**

**Web:** <http://www.ruggedcom.com/>  
**Tel:** (905) 856-5288  
**Fax:** (905) 856-1995  
**Toll Free:** (888) 264-0006

## Federal Communications Commission Radio Frequency Interference Statement

*This equipment has been tested and found to comply with the limits for a Class A digital device pursuant to Part 15 of the FCC Rules. These limits are designed to provide reasonable protection against harmful interference when the equipment is operated in a commercial environment. This equipment generates, uses and can radiate radio frequency energy and, if not installed and used in accordance with the instruction manual, may cause harmful interference to radio communications. Operation of this equipment in a residential area is likely to cause harmful interference in which case the user will be required to correct the interference on his own expense.*

Warning: Changes or modifications not expressly approved by RuggedCom Inc. could void the user's authority to operate the equipment.

**Caution** – This product contains a laser system and is classified as a  
**“CLASS 1 LASER PRODUCT”**

Caution – Use of controls or adjustments or performance of procedures other than those specified herein may result in hazardous radiation exposure. This product contains no user serviceable parts. Attempted service by unauthorized personnel shall render all warranties null and void.

Should this device require service see the “Warranty and Service” section of this installation guide.

### **Important:**

The RuggedMCTM should be installed in a **restricted access location** where access can only be gained by service personnel or users who have been instructed about the reasons for the restrictions applied to the location and about any precautions that shall be taken; and access is through the use of a tool or lock and key, or other means of security, and is controlled by the authority responsible for the location.

### *Trademarks:*

**Ethernet** is a trademark of Xerox Corporation

**Rugged MediaConverter and RuggedMC** is a registered trademark of RuggedCom Inc.

## Table of Contents

1	Product Overview .....	4
1.1	Functional Overview .....	4
1.2	Feature Highlights.....	4
1.3	RuggedMC™ Front Panel Description .....	5
1.4	RuggedMC™ Side and Bottom View .....	6
2	Installation .....	7
2.1	DIN Rail Mounting.....	7
2.2	Panel Mounting.....	8
2.3	Power Supply Wiring and Grounding .....	9
2.4	RJ45 Ports – Signal Description .....	10
3	<i>Specifications</i> .....	11
3.1	Power Supply Specifications.....	11
3.2	Twisted-Pair Port Specifications .....	11
3.3	Fiber Optical Port Specifications.....	12
3.4	Networking Standards Supported .....	12
3.5	Operational Specifications .....	13
3.6	Mechanical Specifications .....	14
4	Type Test Specifications .....	15
4.1	Operating Environment.....	16
4.2	Agency Approvals.....	16
5	Warranty.....	16

# 1 Product Overview

## 1.1 Functional Overview

The **Rugged MediaConverter™** is an industrially hardened fiber optical media converter specifically designed to operate in harsh environments such as those found in electric utility substations and factory floors. The RMC40™ provides industrial strength Ethernet copper-to-fiber media conversion, providing copper-based 10BaseT or 100BaseTx clients 100BaseFX fiber optical connectivity.

Specifically tested to the same standards as mission critical protective relaying equipment (i.e. ANSI/IEEE C37.90 and IEC 60255), and the newly issued IEC 61850-3 “Communications Systems and Networks in Substations” standard, the RuggedMC™ is ideally suited for substation or industrial environments. The reliability of the Rugged MediaConverter™ family exceeds that of commercial media converters by having no rotating mechanical parts (i.e. no cooling fans), utilizing high-temperature solid state components and incorporating the necessary transient and surge suppression circuitry required for substation and harsh industrial environments.

## 1.2 Feature Highlights

- Utility Grade (i.e. substation hardened) per ANSI/IEEE C37.90, IEC 60255, and the new IEC 61850-3 (2002), IEC 61000-6-5 standards
- Operating temperature: -40° to 85°C (no fan)
- Radiated RF Immunity: 35V/m per ANSI/IEEE C37.90.2
- Power supply options: 24 (10-36VDC), 48 (36-72) or HI (88-300VDC / 85-264VAC)
- 2 – 10/100BaseTx RJ45 style auto-negotiating Ethernet ports
- Choice of one of the following:
  - 1 – 100BaseFX (100Mbps) SC style connector (multimode or single-mode) transceiver
  - 2 - 100BaseFX (100Mbps) MTRJ (multimode) or LC (single-mode) style transceivers
- Full-Duplex operation on all ports (no collisions)
- Non-blocking, low latency switching with IEEE 802.3x flow-control protocol results in high-speed reliable communications.

### 1.3 RuggedMC™ Front Panel Description

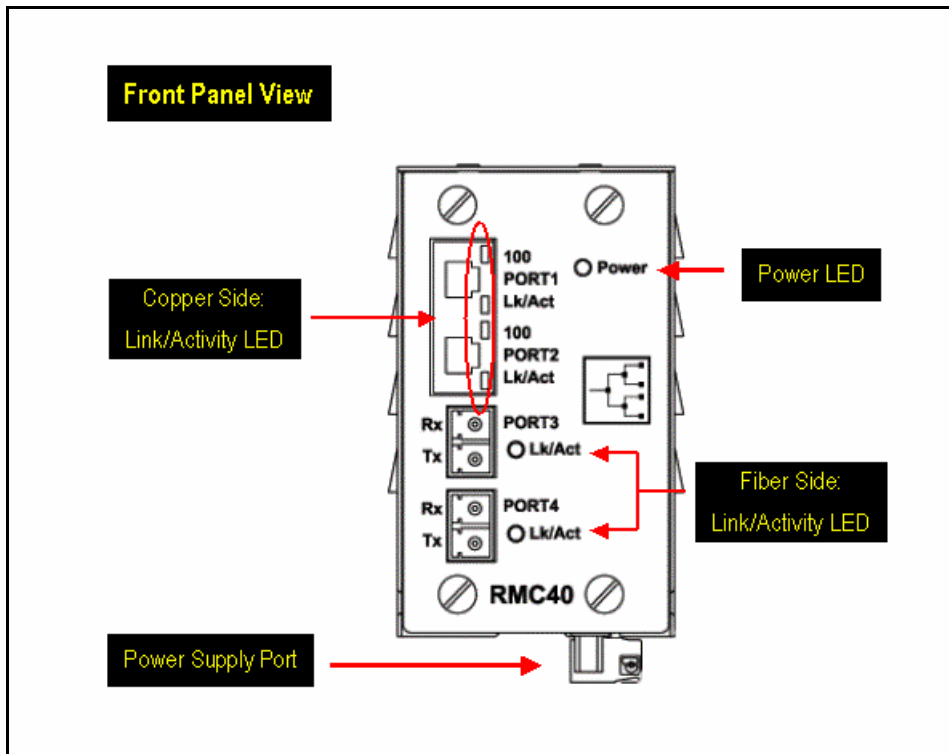

Fig. 1.3.1 RuggedMC™ Front Panel Detail (Dual LC Style 100BaseFX fiber optic connector shown)

ITEM	Activity	Comments
RJ45: Lk/Act	Solid (Yellow)	Link Established
	Blinking (Yellow)	Tx, Rx Activity
RJ45: 100	Solid (Yellow)	100Mbps Operation
	Off	10Mbps Operation
Fiber: Lk/Act	Solid (Yellow)	Link Established
	Blinking (Yellow)	Tx, Rx Activity
Power LED	Solid (Green)	Power On

## 1.4 RuggedMC™ Side and Bottom View

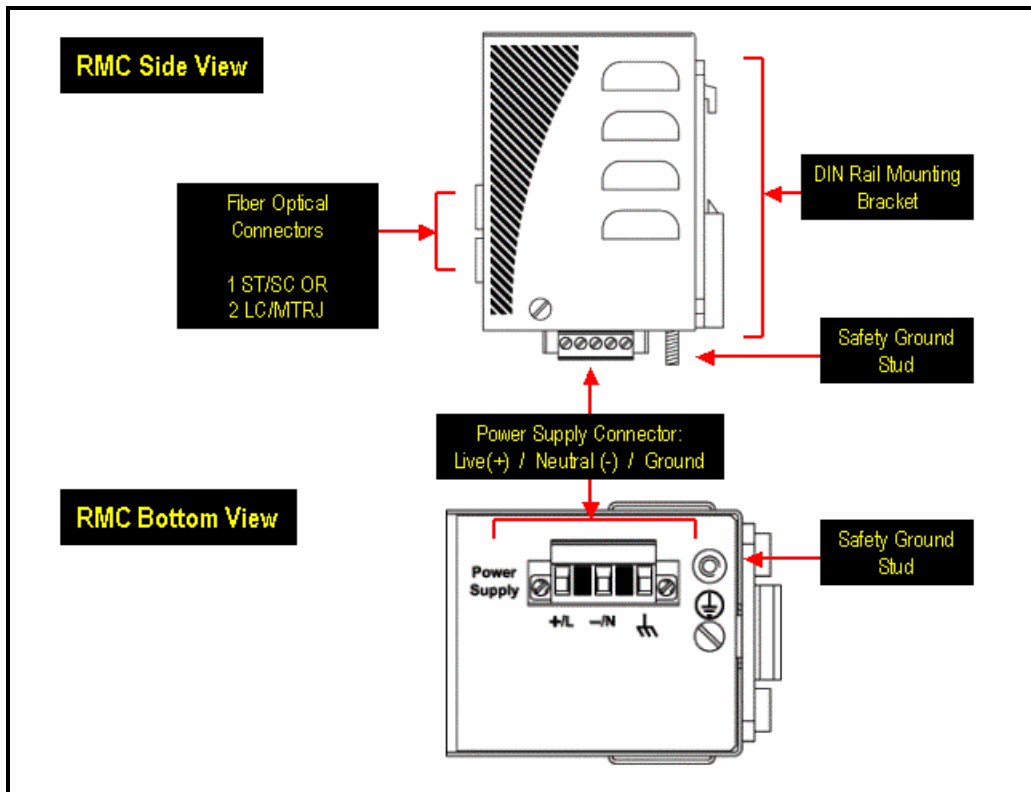

Fig. 1.4.1 RuggedMC™ Side and Bottom View

## 2 Installation

### 2.1 DIN Rail Mounting

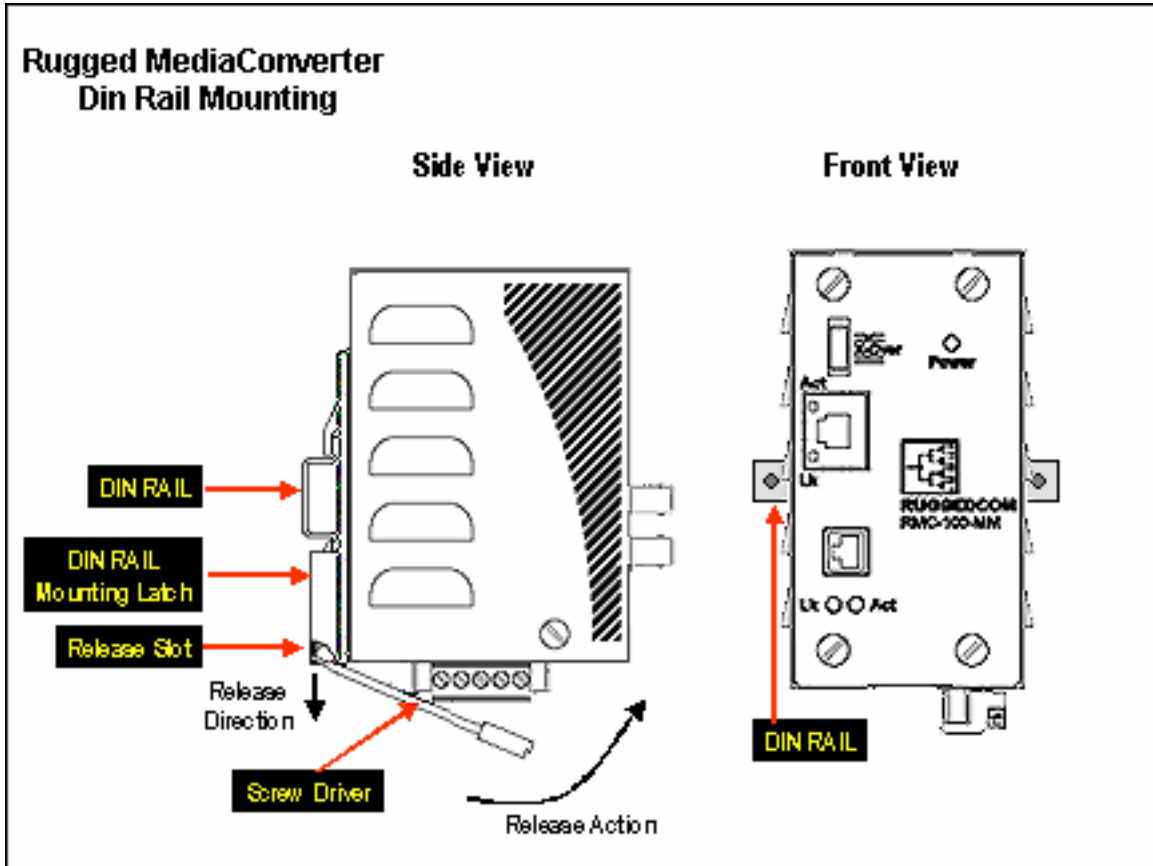

Fig. 2.1.1 RuggedMCT™ DIN Rail Mounting

## 2.2 Panel Mounting

With the use of an optional panel-mount adapter, the RuggedMC™ series of media converters can be panel mounted. The drawing shown in Figure 2.2.1 shows an example of an RMC unit panel mounted using the optional panel mount adapter.

The panel mount adapter can be secured to a panel with three screws. The RuggedMC™ product is easily mounted onto the panel mount adapter via the two metal clips on either side of the unit, and a single screw located on the bottom.

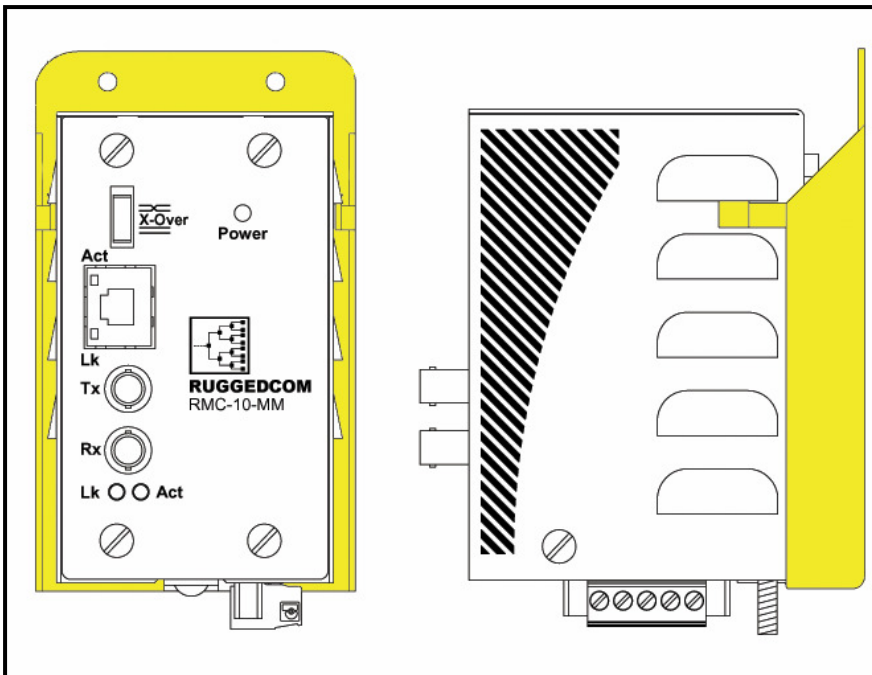

Figure 2.2.1: RuggedMC panel mounted using optional panel mount mounting adapter.



## 2.3 Power Supply Wiring and Grounding

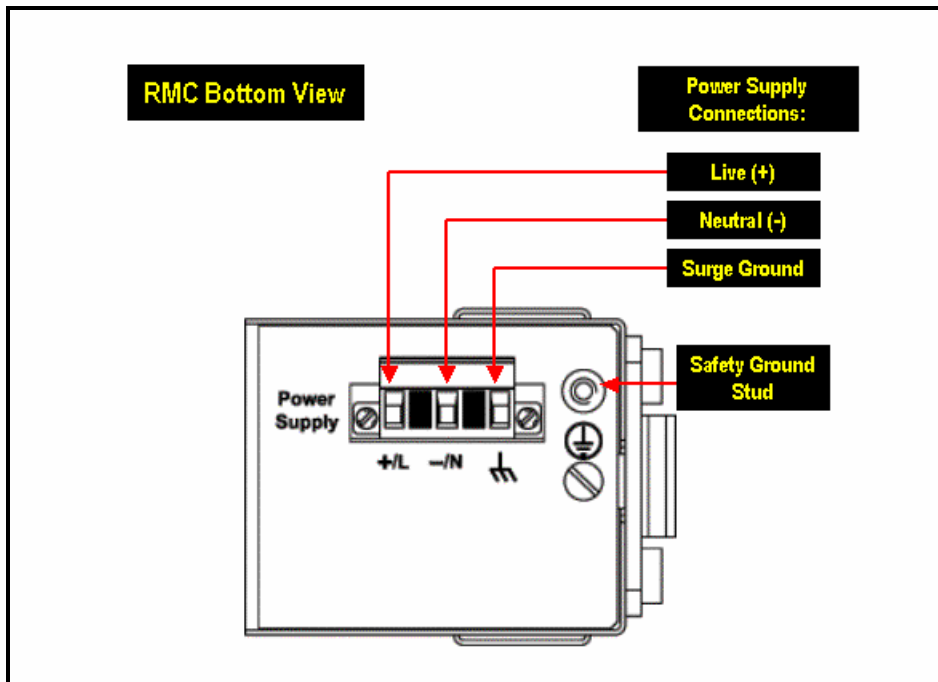

Fig. 2.2.1 RuggedMCTM Power Supply Inputs

The RuggedMCTM power supply inputs are identical and are connected as follows:

1. **+/L** = DC (+) / AC (Hot) is connected to the positive (+) terminal if the power source is DC or to the (Hot) terminal if the power source is AC.
2. **-/N** = DC (-) / AC (Neutral) is connected to the negative (-) terminal if the power source is DC or to the (Neutral) terminal if the power source is AC.
3. **Surge Ground** is connected to the Chassis Ground via a braided cable or other appropriate grounding wire. Surge Ground is used as the ground conductor for all surge and transient suppression circuitry internal to the RuggedMCTM.

*Chassis Ground is connected to the Safety Ground terminal for AC inputs or the equipment ground bus for DC inputs.*

**Note: Surge Ground must be disconnected from Chassis Ground during HIPOT (dielectric strength) testing.**

### Notes:

1. **For 125/250VDC rated equipment: An appropriately rated 300VDC circuit breaker must be installed within 3 meters of unit.**
2. **For 110/230VAC rated equipment: An appropriately rated 250VAC circuit breaker must be installed within 3 meters of the unit**
3. **A circuit breaker is not required for 48 or 24VDC rated equipment.**
4. **For multiple supplies, separate circuit breakers must be installed. Equipment must be installed according to the applicable country wiring codes.**

## 2.4 RJ45 Ports – Signal Description

The RJ45 port accepts standard category 5 unshielded twisted pair (UTP), or screened twisted pair (STP) cable with RJ45 male connectors. Fig. 2.3.1 shows the RJ45 port pin configuration. Both RJ45 Ethernet ports on the RMC40™ are auto-crossover, auto-polarity, auto-crossover (MDI / MDIX) equipped, for simple plug-and-play operation.

Although transient suppression circuitry is present on all RJ45 ports, they **cannot** protect the port from high-amplitude, high-energy transients that can potentially damage the RMC40™ and its link partners. In general, RuggedCom strongly recommends limiting connections used by the RJ45 ports to those that are less than 3m in length, or limited to environments sufficiently protected from such transients.

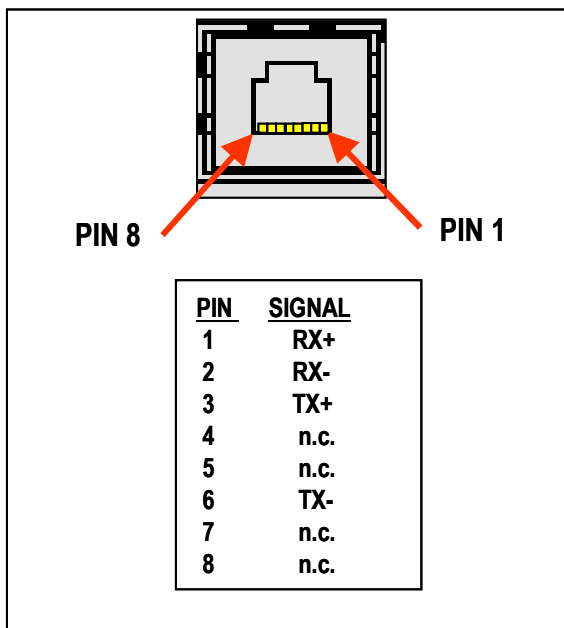

Fig. 2.3.1 RJ45 Port Pins

**NOTE:** For substation applications it is not recommended to use these ports to interface to field devices across distances which could produce high levels of ground potential rise (GPR), (i.e. greater than 2500V) during line-to-ground fault conditions.

### 3 Specifications

#### 3.1 Power Supply Specifications

Power Supply Type	Minimum Input	Maximum Input	Fuse Rating	Maximum Power Consumption
24 VDC	18 VDC	36 VDC	3.15A(T) <sup>2</sup>	3 W
48 VDC	36 VDC	72 VDC	3.15A(T) <sup>2</sup>	
HI (88/300 VDC) <sup>1</sup> HI (120/240 VAC) <sup>1</sup>	88 VDC 85 VAC	300 VDC 264 VAC	3.15A(T) <sup>2</sup>	

Notes: 1 – This is the same power supply for both AC and DC.

2 – (T) Denotes time-delay fuse

**CAUTION:** For continued protection against risk of fire, replace only with same type and rating of fuse.

#### 3.2 Twisted-Pair Port Specifications

Parameter	Specification	Notes
Speed	10/100 Mbps	Auto-negotiating
Duplex	FDX / HDX	Auto-negotiating
Cable-Type	> Category 5	Shielded/Unshielded
Wiring Standard	TIA/EIA T568A/B	Auto-Crossover, Auto-polarity
Max Distance	100m	
Connector	RJ45	
Isolation	1.5kV	RMS 1-minute

### 3.3 Fiber Optical Port Specifications

Speed Standard	Mode / Connector	Tx $\lambda$ (nm)	Cable Type <sup>2</sup> ( $\mu$ m)	Tx Pwr (dBm peak) <sup>3</sup> (Min / Max)	Rx Sensitivity (dBm Average) <sup>3</sup>	Rx Saturation (dBm Peak) <sup>3</sup>	Typical Distance (km) <sup>1</sup>	Power Budget (dB)
100BaseFX	MM / ST	1310	50/125	-15.7	-33.5	-11	2	17
100BaseFX	MM / SC	1310	50/125	-16/-11	-33	-11	2	17
100BaseFX	MM / LC	1310	50/125	-19 / -14	-32	-14	2	15
100BaseFX	MM / MTRJ	1310	50/125	-16/-11	-33.5	-11	2	17
100BaseFX	SM / SC	1310	9/125	-13/5	-31	-4	20	20
100BaseFX	SM / LC	1310	9/125	-15/-8	-31	-5	15	16.5

Notes:

1. Maximum segment length is greatly dependent on factors such as fiber quality, and number of patches and splices. Please consult RuggedCom sales associates when determining maximum segment distances.
2. To convert from average to peak add 3 dBm. To convert from peak to average, subtract 3 dBm.

### 3.4 Networking Standards Supported

Parameter	10FL Module	100FX Module	Notes
IEEE 802.3	✓		10BaseT
IEEE 802.3u		✓	100BaseTX / 100BaseFX
IEEE 802.3x	✓	✓	FDX, Flow Control

### 3.5 Operational Specifications

<b>Parameter</b>	<b>Specification</b>	<b>Notes</b>
Conversion Type	Cut-Through	High-speed, non-blocking
Mac Address Table Length	2048	
Frame Buffer Memory	1Mbit	

### 3.6 Mechanical Specifications

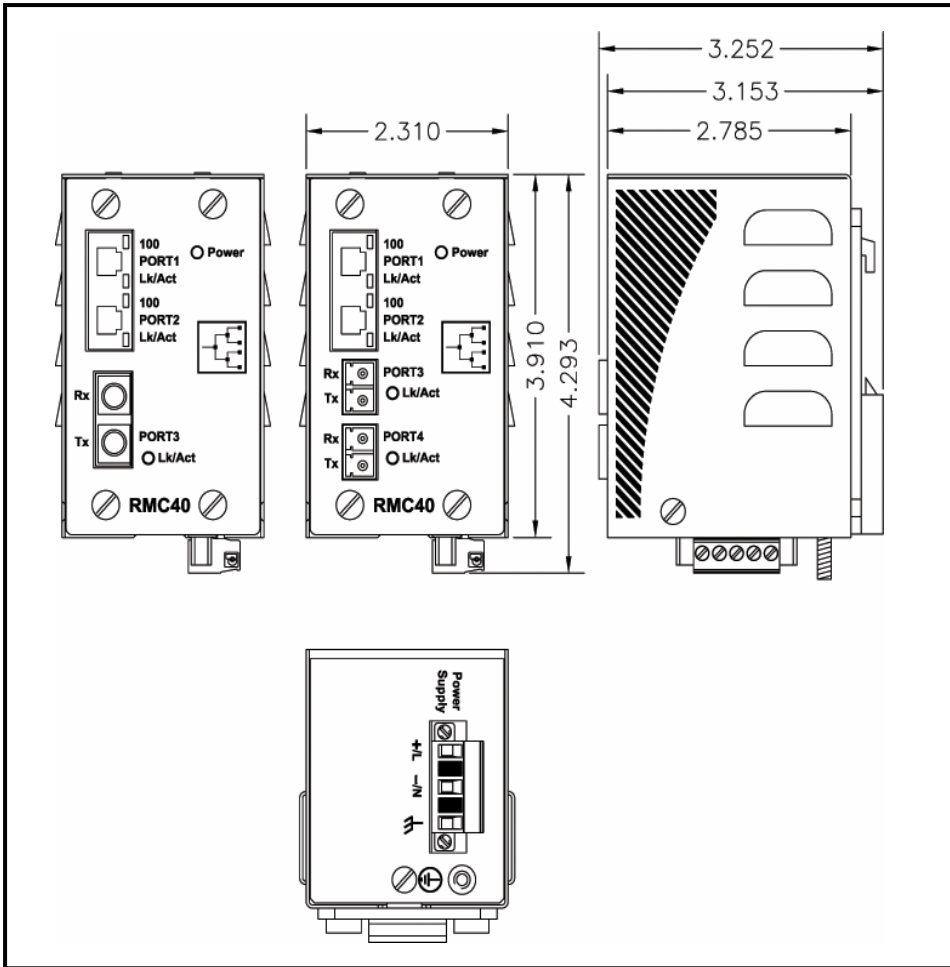

Parameter	Value	Comments
Dimensions	4.30 x 2.40 x 3.30 inches (110) x (61) x (84) mm	(Length x Width x Height)
Weight	1.5 lb (0,68 Kg)	
Enclosure	18 gauge Galvanized Steel	

## 4 Type Test Specifications

<b>Electrical Safety</b>	<b>Levels</b>	<b>Comments</b>
Dielectric Withstand	2 kV rms for 1 minute	ANSI/IEEE C37.90 (1989) IEC 60255-5 (Section 6)
High Voltage Impulse	5 kV peak	IEC 60255-5 (Section 8)
Insulation Resistance	500 VDC for 1 minute	IEC 60255-5 (Section 6)

<b>Electrical Environment</b>	<b>Levels</b>	<b>Comments</b>
High Frequency Disturbance (Oscillatory)	2.5 kV @ 1MHz for 2s	ANSI/IEEE C37.90.1 IEC 60255-22-1
IEC Surge	4 kV / 2 kV	IEC 61000-4-5 (Level 4)
IEC Fast Transient	2 kV / 1 kV	IEC 61000-4-4 (Level 4)
ANSI/IEEE Fast Transient	4 kV	ANSI/IEEE C37.90.1
IEC Radiated RFI Immunity	10 V/m	IEC 61000-4-3
ANSI/IEEE Radiated RFI Immunity	35 V/m	ANSI/IEEE C37.90.2
ESD (Electrostatic Discharge)	15 kV (air discharge) 8 kV (contact)	IEC 61000-4-2 (Level 4)

<b>Atmospheric Environment</b>	<b>Levels</b>	<b>Comments</b>
Temperature (Dry Cold)	-40°C	IEC 60068-2-1 Test Ad: 16 hrs @ -40°C
Temperature (Dry Heat)	85°C	IEC 60068-2-2 Test Bd: 16 hrs @ 85°C
Humidity	95% Non-condensing	IEC 60068-2-30 Test Db: 6 cycles, 55°C, 95% Humidity

## 4.1 Operating Environment

<b>Parameter</b>	<b>Range</b>	<b>Comments</b>
Ambient Operating Temperature	-40 to 85°C	Ambient Temperature as measured from a 30cm radius surrounding the center of the RuggedMC™ enclosure.
Ambient Relative Humidity	5% to 95%	Non-condensing
Ambient Storage Temperature	-40 to 85°C	

## 4.2 Agency Approvals

<b>Agency</b>	<b>Standards</b>	<b>Comments</b>
CSA, CE	CSA C22.2 No. 60950, UL 60950, EN 60950, EN 61000-6-2	Approved
FCC	FCC Part 15, Class A	Approved
CISPR	EN55022, Class A	Approved
FDA/CDRH	21 CFR Chapter 1, Subchapter J	Compliant
IEC/EN	EN60825-1:1994 + A11:1996 + A2:2001	Compliant

## 5 Warranty

RuggedCom warrants this product for a period of five (5) years from date of purchase. For warranty details, visit <http://www.ruggedcom.com/> or contact your customer service representative.

Should this product require warranty or service contact the factory at:

RuggedCom Inc.  
30 Whitmore Road  
Woodbridge, Ontario  
Canada L4L 7Z4  
Phone: (905) 856-5288  
Fax: (905) 856-1995



## Free Manuals Download Website

<http://myh66.com>

<http://usermanuals.us>

<http://www.somanuals.com>

<http://www.4manuals.cc>

<http://www.manual-lib.com>

<http://www.404manual.com>

<http://www.luxmanual.com>

<http://aubethermostatmanual.com>

Golf course search by state

<http://golfingnear.com>

Email search by domain

<http://emailbydomain.com>

Auto manuals search

<http://auto.somanuals.com>

TV manuals search

<http://tv.somanuals.com>