



INSTALLATION/OPERATION MANUAL

CRYSTAL S E R I E S L

CX-70DHD

**1080p, High-Definition Flat Panel LCD
and Digital High Definition (DHD) Controller/Scaler/Processor
with Widevision™**



RuncoCare™ Standard Two Year Limited Warranty

Congratulations on your purchase of a Runco® product! With proper installation, setup and care, you should enjoy many years of unparalleled video performance.

This RuncoCare Standard Limited Warranty is provided free of charge by Runco International with the purchase of a covered Runco product. The following sets forth Runco's Standard Limited Warranty applicable to all Runco projectors, processors, LCD and plasma display products, with the exception of the following models: XP-103DHD, SC-1, SC-1a and VW-100HD¹.

The following terms and conditions of the RuncoCare Standard Limited Warranty represent a contract between us, Runco International and you, the customer who has purchased a Runco product. This contract applies to purchases of covered Runco products occurring on or after September 1, 2008. Runco reserves the right to change the terms of this contract, and such changes shall apply to purchases of covered Runco products that occur on or after any future effective date.

RuncoCare Standard Features

- Two-year protection from defects in material and workmanship
- Access to 24x7 phone support
- Complimentary, second-day one-way shipping

Warranty Coverage

Runco warrants its products to be free from defects in material and workmanship during the warranty period provided below. If, in Runco's determination, a product proves to be defective in material or workmanship during the warranty period, Runco will repair the product, replace the product with a similar new or like new product, or refund a prorata share of the purchase price (calculated based on the remainder of the warranty period and the then current MSRP² of a similar product), if repair or replacement of the product is determined by Runco to not be feasible.

Length of Warranty

Runco products are warranted for two (2) years from the date of shipment from Runco. Lamps are warranted six (6) months from the date of shipment or 1000 hours, whichever comes first. All other accessories, which includes, but is not limited to, cables, remotes, carrying cases, lens cap and other peripherals sold with the Runco product, are warranted for ninety (90) days from the date of shipment. Repaired product or replacement lamp is subsequently warranted for the remaining portion (if any) of the original warranty term or 90 days from the date the product was shipped to you, whichever is longer.

Eligibility

This RuncoCare Standard Limited Warranty is valid only for the first customer who purchases the covered product from an authorized Runco dealer or distributor. This warranty is not transferable. You may be required to provide proof of purchase in order to receive warranty services.

-
1. Runco may update this list of products excluded from this warranty from time to time at Runco's sole discretion, but updates to the list of covered products will not apply on a retroactive basis.
 2. MSRP is defined as the most recent product price listed on Runco's price list.

RuncoCare Claim Procedure

In the event of a product defect, please follow the warranty claim procedure provided below:

1. The Customer is required to contact a Runco dealer or Runco Technical Support via email at support@runco.com or via phone at (toll free) 800-23RUNCO (800-237-8626). If the customer is located outside North America, call +3589 4200 554 in Europe for product service.
2. Be prepared to provide the date of purchase, the place of purchase, serial number, product model number, description of the problem and troubleshooting steps already attempted.
3. Runco Technical Support staff will attempt to correct any minor issues that may be causing the problem. If Runco is unable to fix the problem to the customer's satisfaction, Runco will issue a Return Material Authorization (RMA) if it is determined that the claim was made within the coverage period of the Standard Limited Warranty.
4. The customer will need to return the defective product to the Runco repair depot location specified by the Runco technical support representative. The customer will need to properly package the defective product, consisting of the product only, and not include any accessories (e.g., cables, remotes, carrying cases, lens, lens cap and other peripherals) and return it to the Runco repair depot specified by the technical support representative. It is the customer's responsibility to properly package the hardware, include all appropriate materials, and return it to the location specified by the Runco technical support department. The customer will need to address and resolve any shipping damage claims directly with the shipping company.
5. The customer is responsible for providing a suitable box to ship the defective product to an authorized Runco repair depot. Boxes may be purchased from a Runco technical support representative.
6. The customer is responsible for paying freight charges to ship the defective product to an authorized Runco repair depot.
7. Runco will pay freight charges to return the repaired/replacement product to the customer from the Runco repair depot.
8. Once an RMA has been created, the customer may contact serviceorders@runco.com for followup questions or confirmation status of the claim process.

Warranty Exclusions

This RuncoCare Standard Limited Warranty does not include or is limited by the following:

1. Products not purchased from an authorized Runco dealer
2. Rental costs incurred by the customer in the event of product defect or failure
3. Any product with a defaced, modified, or removed serial number
4. Damage, deterioration, or malfunction resulting from:
 - a Accident, abuse, misuse, neglect, improper ventilation, fire, water, disaster, lightning, or other acts of nature, smoke exposure (cigarette or otherwise), unauthorized product modification (including use of an unauthorized mount), or failure to follow instructions supplied with the product
 - b Repair or attempted repair by anyone not authorized by Runco
 - c Any damage to the product due to shipment
 - d Removal or installation of the product
 - e Causes external to the product, such as electric power fluctuations or failure
 - f Use of supplies or parts not meeting Runco's specifications
 - g Normal wear and tear
 - h Expected lamp degradation and normal decrease in lamp output over a period of time or as the lamp is consumed
 - i Customer caused defects, including but not limited to, scratched/defaced/altered plastics

-
- j Failure to follow maintenance procedures as outlined in the product's user guide where a schedule is specified for regular cleaning of the product
 - k Opening the product and/or tampering with internal circuitry
 - l Products lost, stolen or discarded
 - m Any damage or dissatisfaction associated with latent images, "burnin," or any other damage determined by Runco to be the result of customer use patterns
 - n Any other cause, which does not relate to a product defect in material or workmanship
5. Removal, installation, and setup service charges are excluded from this Standard Limited warranty
 6. Runco's warranty does not cover black uniformity issues or other LCD issues associated with usage outside the Runco recommended guidelines and specifications for the product
 7. Second day shipment delivery time and availability may vary based on origin and destination and Runco is unable to deliver to PO Box and FPO Box addresses

Extended Service Options

Runco offers extended and expanded service plans. For information on additional product protection, please email serviceorders@runco.com or call (toll free) 800-23RUNCO (800-237-8626).

Online Product Registration

Please visit <http://www.runco.com/info.html> to register product.

Limitation of Implied Warranties

RUNCO PROVIDES NO WARRANTIES, EXPRESS OR IMPLIED, EXCEPT THOSE EXPRESSLY PROVIDED HEREIN. RUNCO EXPRESSLY DISCLAIMS ALL OTHER WARRANTIES, INCLUDING THE IMPLIED WARRANTIES OF MERCHANTABILITY AND FITNESS FOR A PARTICULAR PURPOSE.

Exclusion of Damages

RUNCO'S MAXIMUM AGGREGATE LIABILITY HEREUNDER IS LIMITED TO THE COST OF REPAIR OR REPLACEMENT OF THE PRODUCT.

1. RUNCO SHALL NOT BE LIABLE FOR DAMAGE TO OTHER PROPERTY CAUSED BY ANY DEFECT IN THE PRODUCT, DAMAGES BASED UPON INCONVENIENCE, LOSS OF USE OF THE PRODUCT, LOSS OF TIME, LOSS OF PROFITS, LOSS OF BUSINESS OPPORTUNITY, LOSS OF GOODWILL, INTERFERENCE WITH BUSINESS RELATIONSHIPS, OR OTHER COMMERCIAL LOSS, EVEN IF THE CUSTOMER HAS BEEN ADVISED OF THE POSSIBILITY OF SUCH DAMAGES.
2. RUNCO SHALL NOT BE LIABLE FOR ANY CONSEQUENTIAL, INCIDENTAL, INDIRECT, SPECIAL, OR PUNITIVE DAMAGES ANY OTHER DAMAGES, WHETHER INCIDENTAL, INDIRECT, CONSEQUENTIAL OR OTHERWISE.
3. RUNCO SHALL NOT BE LIABLE FOR ANY CLAIM AGAINST THE CUSTOMER BY ANY OTHER PARTY.

Effect of Local Law

This warranty gives you specific legal rights, and you may have other rights, which vary from locality to locality. Some localities do not allow limitations on implied warranties and/or do not allow the exclusion of incidental or consequential damages, so the above limitations and exclusions may not apply to you.

COPYRIGHT AND TRADEMARKS:

© Copyright 2009 Runco International, LLC ("Runco"). This document contains proprietary information protected by copyright, trademark and other intellectual property laws. All rights are reserved. No part of this manual may be reproduced by any mechanical, electronic or other means, in any form, without prior written permission of Runco.

The trademarks reproduced in this Runco Owner's Manual and used on the Runco Products are either owned by Runco or are licensed by Runco. You may not reproduce or use the trademarks without the prior written consent of Runco.

Runco Products are manufactured under one or more of the following patents: US. Patent 6755540 and Other Patents Pending.

Important Safety Instructions

Thank you for your purchase of this quality Runco video product! It has been designed to provide you with the quality of video that is expected in a home theater. For the best performance, please read this manual carefully as it is your guide through the menus and operation.

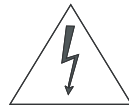
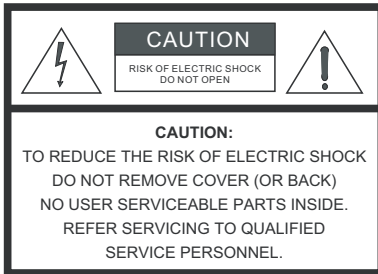

WARNING

This symbol is intended to alert the user to the presence of uninsulated “dangerous voltage” within the product’s enclosure that may be of sufficient magnitude to constitute a risk of electric shock.



This symbol is intended to alert the user to the presence of important operating and maintenance (servicing) instructions in the literature accompanying the appliance.

1. Read these instructions.
2. Keep these instructions.
3. Heed all warnings.
4. Follow all instructions.
5. Do not use this apparatus near water.
6. Clean only with a dry cloth.
7. Do not block any of the ventilation openings. Install in accordance with the manufacturer’s instructions.
8. Do not install near any heat sources such as radiators, heat registers, stoves, or other apparatus (including amplifiers) that produce heat.
9. Do not defeat the safety purpose of the polarized or grounding type plug. A polarized plug has two blades with one wider than the other. A grounding type plug has two blades and a third grounding prong. The wide blade or the third prong is provided for your safety. When the provided plug does not fit into your outlet, consult an electrician for the replacement of the obsolete outlet.
10. Protect the power cord from being walked on or pinched particularly at plugs, convenience receptacles and the point where they exit from the apparatus.
11. Only use the attachments/accessories specified by the manufacturer.
12. Use only with a cart, stand, tripod, bracket or table specified by the manufacturer or sold with the apparatus. When a cart is used, use caution when moving the cart/apparatus to avoid injury from tip-over.
13. Unplug this apparatus during lightning storms or when unused for long periods of time.
14. Refer all servicing to qualified service personnel. Servicing is required when the apparatus has been damaged in any way, such as power supply cord or plug is damaged, liquid has been spilled or objects have fallen into the apparatus, the apparatus has been exposed to rain or moisture, does not operate normally, or has been dropped.
15. Keep the packing material in case the equipment should ever need to be shipped.



Compliance Information

DECLARATION OF CONFORMITY:

Manufacturer's Name: Runco International, LLC

Manufacturer's Address: 1195 NW Compton Drive, Beaverton, OR 97006-1992

hereby declares that the Products' Model Numbers:

CX-70DHD

conform with the provisions of:

Council Directive 2004/108/EC on Electromagnetic Compatibility;

EN 55022 "Limits and methods of measurements of radio interference characteristics of information technology equipment" 1998;

EN 55024 "Limits and methods of measurements of immunity characteristics of information technology equipment" 1998;

Including:

- EN 61000-4-2 "Electromagnetic compatibility (EMC) Part 4: Testing and measurement techniques Section 2: Electrostatic discharge immunity test"
- EN 61000-4-3 "Electromagnetic compatibility (EMC) Part 4: Testing and measurement techniques Section 3: Radiated, Radio-Frequency, Electromagnetic Field Immunity Test"
- EN 61000-4-4 "Electromagnetic compatibility (EMC) Part 4: Testing and measurement techniques Section 4: Electrical fast transient/burst immunity test"
- EN 61000-4-5 "Electromagnetic compatibility (EMC) Part 4: Testing and measurement techniques Section 5: Surge immunity test"
- EN 61000-4-6 "Electromagnetic compatibility (EMC) Part 4: Testing and measurement techniques Section 6: Conducted disturbances induced by radio-frequency fields immunity test"
- EN 61000-4-8 "Electromagnetic compatibility (EMC) Part 4: Testing and measurement techniques Section 8: Conducted disturbances induced by power frequency magnetic fields immunity test"
- EN 61000-4-11 "Electromagnetic compatibility (EMC) Part 4: Testing and measurement techniques Section 11: Voltage dips, short interruptions and voltage variations immunity tests"

And:

- EN 61000-3-2 "Electromagnetic compatibility (EMC) Part 3, Section 2: Limits for harmonic current emissions (equipment input current up to and including 16 A per phase)" 2000;
- EN 61000-3-3 "Electromagnetic compatibility (EMC) Part 3, Section 3: Limitations of voltage changes, voltage fluctuations and flicker in public low-voltage supply systems, for equipment with rated current up to and including 16 A and not subject to conditional connection" 1995;

Council Directive 2006/95/EC and amended by M1 and C1 on Low Voltage Equipment Safety;

EN 60950 "Safety of information technology equipment, including electrical business equipment"

The Technical Construction file required by this Directive is maintained at the corporate headquarters of Runco International, LLC, located at 1195 NW Compton Drive, Beaverton, OR 97006-1992.

Date of Declaration: February 2009

FCC PART 15:

NOTE: This equipment has been tested and found to comply with the limits for a Class A digital device, pursuant to part 15 of the FCC Rules. These limits are designed to provide reasonable protection against harmful interference when the equipment is operated in a commercial environment.

This equipment generates, uses, and can radiate radio frequency energy and, if not installed and used in accordance with the instruction manual, may cause harmful interference to radio communications. Operation of this equipment in a residential area is likely to cause harmful interference in which case the user will be required to correct the interference at his own expense.

INDUSTRY CANADA (ICES-003):

This Class A digital apparatus complies with Canadian ICES-003.

Cet appareil numérique de la classe A est conforme à la norme NMB-003 du Canada.

PRODUCT DISPOSAL:

The Product contains small amounts of tin, lead and/or mercury. Disposal of these materials may be regulated due to environmental considerations.

IMPORTANT RECYCLE INSTRUCTIONS



This product may contain mercury or other electronic waste that can be hazardous if not disposed of properly. Recycle or dispose in accordance with local, state, or federal Laws.

For more information, contact the Electronic Industries Alliance at WWW.EIAE.ORG.

For lamp specific disposal information check WWW.LAMPRECYCLE.ORG.

DISPOSAL OF OLD ELECTRICAL AND ELECTRONIC EQUIPMENT (Applicable throughout the European Union and other European countries with separate collection programs)



This symbol found on your product or on its packaging, indicates that this product should not be treated as household waste when you wish to dispose of it. Instead, it should be handed over to an applicable collection point for the recycling of electrical and electronic equipment. By ensuring this product is disposed of correctly, you will help prevent potential negative consequences to the environment and human health, which could otherwise be caused by inappropriate disposal of this product. The recycling of materials will help to conserve natural resources. This symbol is only valid in the European Union. If you wish to discard this product, please contact your local authorities or dealer and ask for the correct method of disposal.

Notes:

Table of Contents

RuncoCare™ Standard Two Year Limited Warranty	iii
Important Safety Instructions	vii
Compliance Information	viii
1. Introduction	1
About This Manual	1
Target Audience	1
If You Have Comments About This Manual.....	1
Textual and Graphic Conventions	1
Using This Manual	2
Description, Features and Benefits	3
Key Features and Benefits	3
Parts List	4
2. Controls and Functions	5
CX-70DHD at a Glance	5
Controls and Indicators.....	5
Connectors.....	6
DHD Controller Front Panel	7
DHD Controller Rear Panel	9
Outputs	9
Inputs	9
CX-70DHD Remote Control Unit	11
3. Installation	15
Remote Control	15
Notes on Batteries	15
Notes on Remote Control Operation.....	15
Quick Setup	16
Installation Considerations	17
Ambient Light	17
Ventilation.....	17
Audio/Video Synchronization Issues.....	17
Other Considerations.....	18
Mounting the CX-70DHD on a Wall or Table Stand.....	19
Connections to the CX-70DHD and DHD Controller	21

Connecting the CX-70DHD to the DHD Controller	21
Connecting Source Components to the DHD Controller	23
RS-232 Controller Connection	29
Connecting 12-volt Trigger Outputs to External Equipment	30
Connecting an External IR Receiver to the DHD Controller	31
Connecting AC Power	32
4. Operation	33
Turning on the Power	33
Setting the Computer Display Properties	33
Using the On-Screen Menus	35
Main Menu.....	36
Input Source.....	37
Aspect Ratio.....	37
Picture.....	40
Input Position.....	45
Memory Presets	47
Information	48
Calibration	48
Service	52
5. Maintenance and Troubleshooting	57
Cleaning	57
Cleaning the Display Panel Body and Remote Control	57
Cleaning the Screen.....	57
Cleaning the Vents.....	57
Troubleshooting Tips	57
6. External Control	59
Serial Communications	59
RS-232 Connection and Port Configuration	59
Serial Command Syntax	59
Using Discrete IR Codes	64
IR Command Protocol	64
IR Command List.....	65
7. Specifications	67
CX-70DHD Specifications	67
DHD Controller Specifications	68
CX-70DHD Dimensions	69
Supported Timings	70

List of Figures

2-1. CX-70DHD Controls and Indicators	5
2-2. CX-70DHD Connector Locations.....	6
2-3. DHD Controller Front Panel	7
2-4. DHD Controller Rear Panel	9
2-5. DHD Controller/CX-70DHD Remote Control.....	11
3-1. Available Range of the Remote Control	15
3-2. Ventilation Requirements for Enclosure Mounting	17
3-3. Assembling and Installing the Table Stand.....	20
3-4. Connecting the CX-70DHD to the DHD Controller	22
3-5. RS-232 Connection from the DHD Controller to the CX-70DHD.....	23
3-6. HDMI Source Connections	24
3-7. Component Video Source Connections.....	25
3-8. RGBHV Source Connections.....	26
3-9. SCART RGBS Source Connections.....	27
3-10. S-Video and Composite Video Source Connections	28
3-11. RS-232 Control System Connection.....	29
3-12. Connecting 12-volt Trigger Outputs.....	30
3-13. External IR Receiver Connection.....	31
4-1. CX-70DHD OSD Menu Structure.....	35
4-2. Typical PLUGE Pattern for Adjusting Brightness	40
4-3. Typical Gray Bar Pattern for Adjusting Contrast	41
4-4. Typical Color Bar Pattern for Adjusting Color Saturation and Tint.....	42
4-5. Typical Test Pattern for Adjusting Sharpness	44
4-6. Overscan Modes	46
4-7. CIE 1931 Chromaticity Diagram	49
6-1. RC5 Message Format	65
7-1. CX-70DHD Dimensions (with Table Stand)	69

Notes:

1. Introduction

This Owner's Manual describes how to install, set up and operate a Runco CX-70DHD Flat-Panel LCD and DHD Controller.

Throughout this manual, the Runco CX-70DHD Flat-Panel LCD and DHD Controller are referred to collectively as the "CX-70DHD."

Runco has prepared this manual to help installers and end users get the most out of the CX-70DHD.

Runco has made every effort to ensure that this manual is accurate as of the date it was printed. However, because of ongoing product improvements and customer feedback, it may require updating from time to time. You can always find the latest version of this and other Runco product manuals on-line, at www.runco.com.

Runco welcomes your comments about this manual. Send them to techpub@runco.com.

Text Conventions: The following conventions are used in this manual, in order to clarify the information and instructions provided:

- Remote control button identifiers are set in upper-case bold type; for example, "Press **EXIT** to return to the previous menu."
- Computer input (commands you type) and output (responses that appear on-screen) is shown in monospace (fixed-width) type; for example: "To change the aspect ratio to Letterbox, type `LETTERBOX <Enter>`."
- All keys with functional names are initial-capped, set in bold type and enclosed in angle brackets. These keys are the following: **<Enter>**, **<Spacebar>**, **<Control>**, **<Esc>** and **<Tab>**.
- **<Enter>** indicates that you may press either the RETURN or ENTER key on your computer keyboard if it has both keys.

In addition to these conventions, underlining, boldface and/or italics are occasionally used to highlight important information, as in this example:



Note

*A carriage return **must** be used after each command or string.*

1.1 About This Manual

◀ Target Audience

◀ If You Have Comments About This Manual...

◀ Textual and Graphic Conventions

Graphic Conventions: These symbols appear in numerous places throughout the manual, to emphasize points that you must keep in mind to avoid problems with your equipment or injury:



Tip

TIPS highlight time-saving short cuts and helpful guidelines for using certain features.



Note

NOTES emphasize text with unusual importance or special significance. They also provide supplemental information.



Caution

CAUTIONS alert users that a given action or omitted action can degrade performance or cause a malfunction.



WARNING

WARNINGS appear when a given action or omitted action can result in damage to the equipment, or possible non-fatal injury to the user.



DANGER!

DANGER appears when a given action can cause severe injury or death.

1.2 Using This Manual

Use the following table to locate the specific information you need in this manual.

If you need...	... Turn to page:
Information about obtaining service	iv
General information about the CX-70DHD Flat-Panel LCD and DHD Controller	3
Installation instructions	15
First-time configuration instructions	33
Advanced configuration instructions	48
Troubleshooting tips	57
Specifications for the CX-70DHD Flat-Panel LCD and DHD Controller	67

Following the longstanding tradition of providing the finest custom theater products, Runco proudly unveils its 70-inch Crystal Series™ LCD, the CX-70DHD. Runco's largest LCD flat panel joins the esteemed Crystal Series, which represents the finest Runco has to offer and is a testament to Runco's commitment to deliver the most exquisite flat-panel displays for an unsurpassed large-screen experience. Combining image prowess, impeccable design, flawless function and incredible craftsmanship, the Crystal Series products bespeak unparalleled luxury for the elite few who covet them.

The Runco CX-70DHD is a native "Full-HD" (1920 x 1080) LCD that is ideal for rooms of distinction where a large screen size is desired, but where ambient light makes front projection difficult and the glare of a plasma screen simply unacceptable. In addition to its exceptional contrast ratio and superb gray scaling for true-to-life image quality, the CX-70DHD features the ISF™ (Imaging Science Foundation) calibration suite, including day and night modes for an optimal picture in the most challenging lighting conditions.

Designed exclusively for discriminating tastes, the CX-70DHD is the first LCD flat panel to feature Runco's proprietary external DHD™ video controller/scaler/processor. The DHD not only incorporates Runco's exclusive advanced Vivix III™ digital video processing technology to achieve the highest level of image fidelity, but it also enhances standard-definition digital and NTSC content to near high-definition quality.

Regardless of video source, Runco's CX-70DHD provides rich, detailed HD imagery. While lesser displays may show signs of image distortion, especially at larger screen sizes, the CX-70DHD incorporates Runco's WideVision™ technology with exclusive VirtualWide™ content conversion, which masterfully converts all 4:3 content to widescreen 16:9 aspect ratio and optimizes Anamorphic and Letterbox content with no loss of image integrity.

The CX-70DHD offers exceptional installation flexibility. It measures less than six inches thin for unobtrusive installation on a wall, and the external DHD processor allows for a pristine installation, with just a single HDMI with HDCP output to the display required. All source and component inputs (Composite, S-Video, HDMI with HDCP, and RGB) are handled by Runco's DHD, which, like all of the components, can be hidden from view.

The CX-70DHD includes a discrete remote, RS-232 interface and three, +12 VDC triggers for greater integration capabilities that can help create the ideal entertainment environment with touch-of-a-button convenience. The display's elegant black bezel matches any room décor.

The CX-70DHD offers these key features and benefits:

- 16:9 Native Resolution: 1920 x 1080
- Multiple Aspect Ratios with VirtualWide™ Mode
- Includes DHD with HDMI video controller/processor
- Less than 6 inches thin
- Exceptional detail and artifact-free video enhancement
- ViVix™ video processing with 3:2 film detection circuitry

1.3 Description, Features and Benefits

◀ Key Features and Benefits

Parts List ➤ Your CX-70DHD is shipped with the following items. If any items are missing or damaged, please contact your Runco dealer or Runco Customer Service at (800) 23-RUNCO.

- CX-70DHD Flat-Panel LCD and DHD Controller
- Table Stand
- AC Power Cords (2)
- Remote Control Unit and two (2), AAA-size batteries
- Communication Cable, RJ-11 Male to RJ-45 Male, 20 feet (part number 175-0686-00)
- Rack-mount hardware for the DHD Controller
- CX-70DHD Installation/Operation Manual (this document)
- CX-70DHD Quick Setup Guide

Optional Accessories:

- Wall Mount Kit (part number 956-0285-00)

2. Controls and Functions

2.1 CX-70DHD at a Glance

◀ Controls and Indicators

Figure 2-1 shows the CX-70DHD controls and indicators.

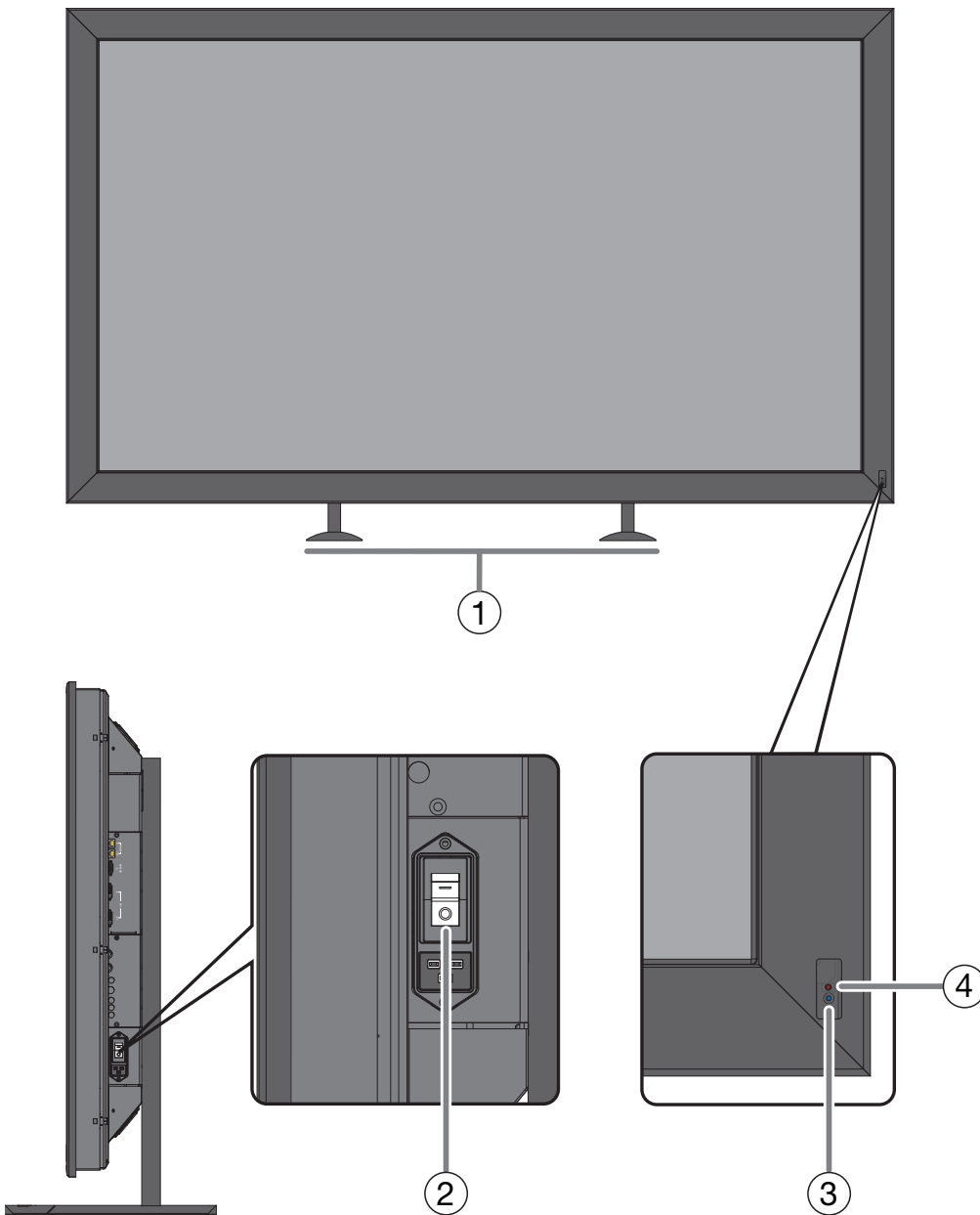

Figure 2-1. CX-70DHD Controls and Indicators

1. **DISPLAY STAND**
Included with the CX-70DHD for table-top installations.
2. **POWER SWITCH**
Connects or disconnects the display panel from the AC power source.
3. **STANDBY/ON INDICATOR**
 - Lights blue to indicate normal operation;
 - Lights red to indicate that the CX-70DHD is in standby mode.
4. **REMOTE CONTROL SENSOR**
Receives the signals from the remote control.

Connectors ➤ Figure 2-2 shows the connector locations on the CX-70DHD, and the paragraphs that follow describe them.

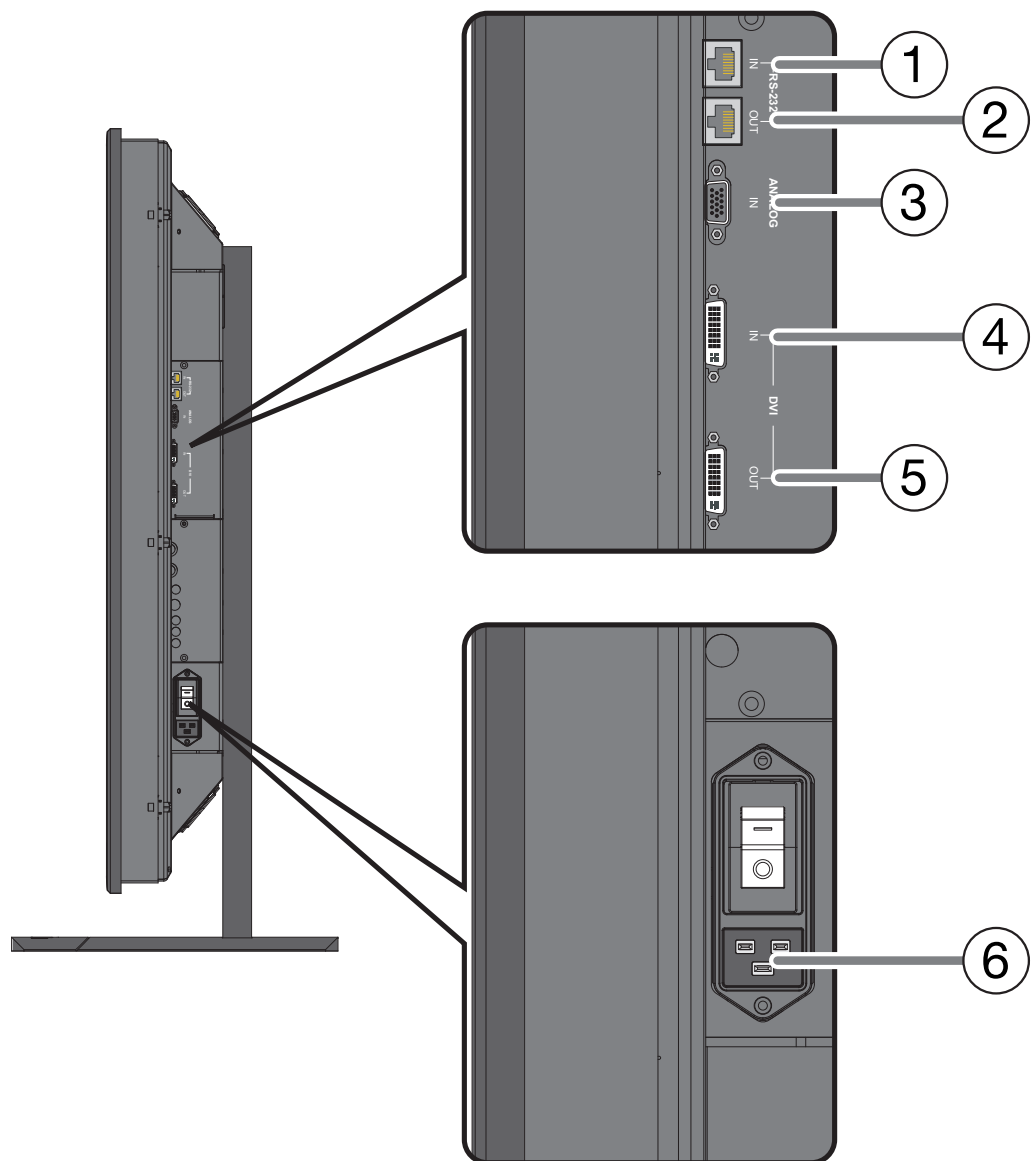

Figure 2-2. CX-70DHD Connector Locations

1. **RS-232 IN**
Connect the **Display Control** output on the DHD Controller to this input (see Figure 2-4).
2. **RS-232 OUT**
Not used.
3. **ANALOG IN**
Not used.
4. **DVI IN**
Connect the HDMI output from the DHD Controller to this input.
5. **DVI OUT**
Not used.
6. **POWER INPUT**
Connect the CX-70DHD to AC power here.

Figure 2-3 shows the controls and indicators on the DHD Controller front panel; the paragraphs that follow describe them.

2.2 DHD Controller Front Panel

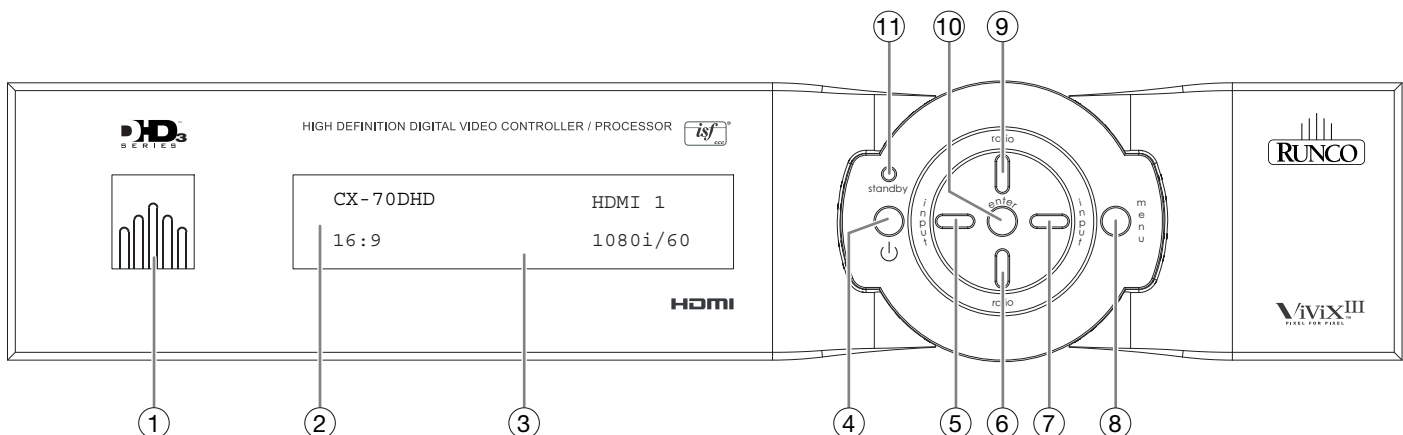

Figure 2-3. DHD Controller Front Panel

1. **RUNCO ICON**
Lights blue to indicate that the controller is on or powering up.
2. **IR SENSOR**
Receives IR commands from the remote control.
3. **VACUUM FLUORESCENT DISPLAY**
Can be used instead of the On-Screen Display (OSD). Displays currently-selected menu or – if no menu is selected – the connected display device model, current source, input resolution and aspect ratio.
4. **ON/STANDBY BUTTON**
Press once to toggle from standby mode to on mode. Press it again to return to standby mode. For a discrete on or off command, you can use the direct access buttons on the remote control.

5. **LEFT BUTTON**

Used to direct-select inputs or move the menu cursor left in the OSD. When no menu is present on-screen, the **LEFT** button toggles through the different sources, in this order:

HDMI 2 - HDMI 1 - SCART - HD 2 - HD 1 - Component - S-Video 2 - S-Video 1 - Composite Video

6. **DOWN BUTTON**

Use to direct-select aspect ratios or move the menu cursor down in the OSD. When no menu is present on-screen, this button toggles through the different aspect ratios, in this order:

16:9 - 4:3 - Letterbox - VirtualWide - Cinema - Virtual Cinema - Native

7. **RIGHT BUTTON**

Used to direct-select inputs or move the menu cursor right in the OSD. When no menus are present on-screen, the **RIGHT** button toggles through the different sources, in this order:

Composite Video - S-Video 1 - S-Video 2 - Component - HD 1 - HD 2 - SCART - HDMI 1 - HDMI 2

8. **MENU BUTTON**

Press the **MENU** button to bring up the main menu, or to exit the current menu and return to the previous one.

9. **UP BUTTON**

Use to direct-select aspect ratios or move the menu cursor up in the OSD. When no menus are present on-screen, the **UP** button toggles through aspect ratios in the following order:

Native - Virtual Cinema - Cinema - VirtualWide - Letterbox - 4:3 - 16:9

10. **ENTER BUTTON**

When an item is highlighted on the OSD, the **ENTER** button selects the item.

11. **STANDBY LED**

Lights amber when the DHD Controller is in standby mode; otherwise it is off.

Figure 2-4 shows the rear connector panel on the DHD Controller.

2.3 DHD Controller Rear Panel

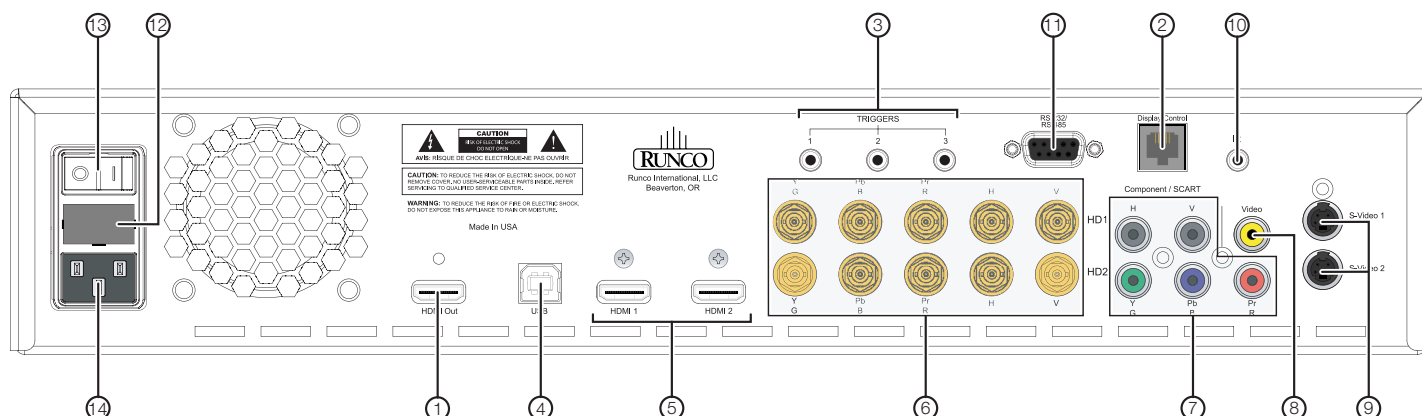

Figure 2-4. DHD Controller Rear Panel

1. HDMI Out

Connect this to the **DVI IN** connector on the CX-70DHD (see Figure 2-2).

2. Display Control

Connect this to the **RS-232** input on the CX-70DHD, using the provided communication cable.

3. TRIGGERS

Connection for up to three (3), 12-volt trigger-controlled devices. Output current is limited to 250 milliamperes (mA).

4. USB

A standard, USB Series "B" connection to a personal computer. (For future use.)

5. HDMI 1 / HDMI 2 (Digital)

HDCP-compliant digital video inputs for connecting an HDMI or DVI source.

6. HD1 / HD2 (5 x Analog BNCs)

Two inputs (five BNCs per input) for connecting standard-definition (SD = 480i/576i), enhanced-definition (ED = 480p/576p) or high-definition (HD = 720p/1080i/1080p) component video sources, or RGBHV sources such as personal computers.

7. Component / SCART (5 x RCA connectors)

SD/HD input for connecting SDTV, EDTV or HDTV component video sources, or RGBHV sources. Also provides RGB input for SCART RGBS sources.

8. Video

Standard, composite video input for connecting a VCR, camcorder or other composite video source. Also provides composite sync input for SCART RGBS sources.

9. S-Video 1 / S-Video 2

Two, standard S-Video inputs for connecting a DVD player, satellite receiver or Super VHS (S-VHS) VCR.

← Outputs

← Inputs

10. **IR**

Wired input from a Niles- or Xantech-compatible, infrared (IR) repeater system. It is a 3.5-mm, mini phono jack, wired as follows:

Ring = No connection

Tip = IR Input

Sleeve = Ground

11. **RS-232 / RS-485**

A female, 9-pin D-sub connector for interfacing with a PC or automation/control system. (Currently, only RS-232 interface is supported.)

12. **MAIN AC FUSE**

This is the main AC input fuse (5mm x 20mm, 500 mA, 250V slow-blow).

13. **MAIN POWER SWITCH**

Disconnects or applies power to the DHD Controller.

14. **POWER INPUT (100 to 240 VAC)**

Connect the DHD Controller to power here.

Figure 2-5 shows the CX-70DHD remote control, and the paragraphs that follow describe its functionality.

2.4 CX-70DHD Remote Control Unit

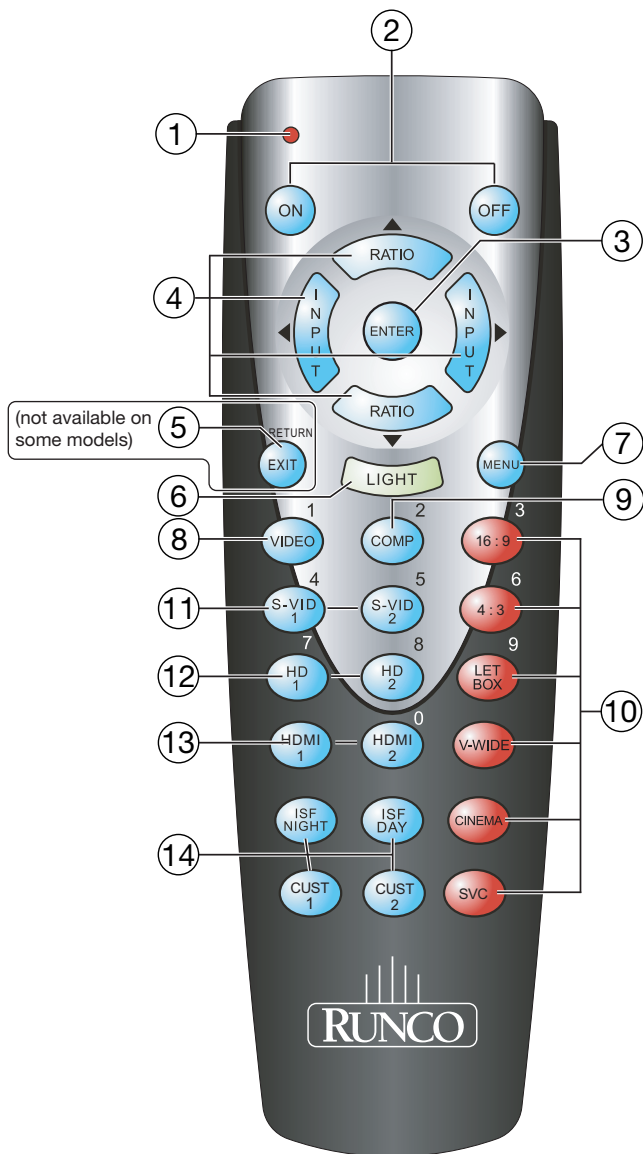

Figure 2-5. DHD Controller/CX-70DHD Remote Control

1. **IR OUTPUT INDICATOR**
Lights when a button is pressed to indicate that an IR signal is being transmitted.
2. **ON / OFF**
Press to turn the display on or off.
3. **ENTER**
Press to select a highlighted menu item or confirm a changed setting.
4. **Cursor Buttons (▲, ◀, ▼, ▶)**
Use these buttons to select items or settings, adjust settings or switch display patterns.

When no menu is present on-screen, the **UP** and **DOWN** buttons toggle through the available aspect ratios, in this order:

UP Button = Native - Virtual Cinema - Cinema - VirtualWide - Letterbox - 4:3 - 16:9

DOWN Button = 16:9 - 4:3 - Letterbox - VirtualWide - Cinema - Virtual Cinema - Native

Likewise, the **LEFT** and **RIGHT** buttons toggle through the different source inputs, in this order:

LEFT Button = HDMI 2 - HDMI 1 - SCART - HD 2 - HD 1 - Component - S-Video 2 - S-Video 1 - Composite Video

RIGHT Button = Composite Video - S-Video 1 - S-Video 2 - Component - HD 1 - HD 2 - SCART - HDMI 1 - HDMI 2

5. **RETURN / EXIT**
Press this button to exit the current menu and return to the previous one.



Note

*Not all remote control units have this button. If yours does not, use the **MENU** button (see below) to exit the current menu.*

6. **LIGHT**
Press to illuminate the buttons.
7. **MENU**
Press this button to access the OSD controls, or to exit the current menu and return to the previous one.
8. **VIDEO (1)**
Press to select Composite video input as the source or to enter the numeric character "1."
9. **COMP (Component) (2)**
Press to select Component/SCART video input as the source or to enter the numeric character "2."

10. Aspect Ratio Selection Buttons

Use the red buttons to select an aspect ratio directly or to enter numeric characters, as follows:

16:9 (3)

For viewing 16:9 DVDs or HDTV programs in their native aspect ratio.

4:3 (6)

Scales the input signal to fit 4:3 display mode in the center of the screen.

LETBOX (Letterbox) (9)

For viewing LaserDisc movies or non-anamorphic DVDs on a 16:9 screen.

V-WIDE (VirtualWide)

Enlarges a 4:3 image horizontally in a NON-linear fashion to fit 16:9 full screen display.

CINEMA

For viewing 2.35:1 source material. The upper and lower portions are masked.

SVC

Selects the Virtual Cinema aspect ratio.

11. S-VID 1 (4) / S-VID 2 (5) (S-Video)

Press to select an S-Video input or to enter the numeric character "4" or "5."

12. HD 1 (7) / HD 2 (8)

Press to select a HD (RGBHV or YPbPr component) input or to enter the numeric character "7" or "8."

13. HDMI 1 / HDMI 2 (0)

Press to select a Digital Video input. Press **HDMI 2** to enter the numeric character "0."

14. Memory Preset Buttons:

ISF NIGHT

Press to recall settings for the current input from the "ISF Night" memory preset.

ISF DAY

Press to recall settings for the current input from the "ISF Day" memory preset.

CUST 1

Press to recall settings for the current input from the "Custom 1" memory preset.

CUST 2

Press to recall settings for the current input from the "Custom 2" memory preset.

Notes:

3. Installation

To install batteries in the remote control:

1. Press down the tab on the cover and pull the cover in the direction of the arrow.
2. Insert the included batteries. Ensure that the polarities correctly match the ⊕ and ⊖ markings inside the battery compartment.
3. Insert the lower tab of the cover into the opening, and press down the cover until it clicks in place.

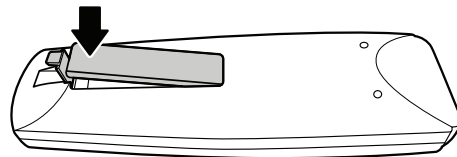
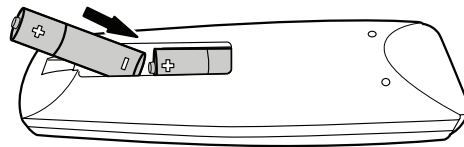
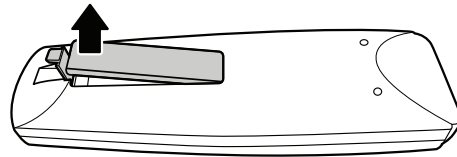

- When installing batteries, make sure that the battery polarities are correct.
- Do not mix an old battery with a new one or different types of batteries.
- If you will not use the remote control for a long time, remove the batteries to avoid damage from battery leakage.

The remote control can be used to control the CX-70DHD within the ranges shown in Figure 3-1.

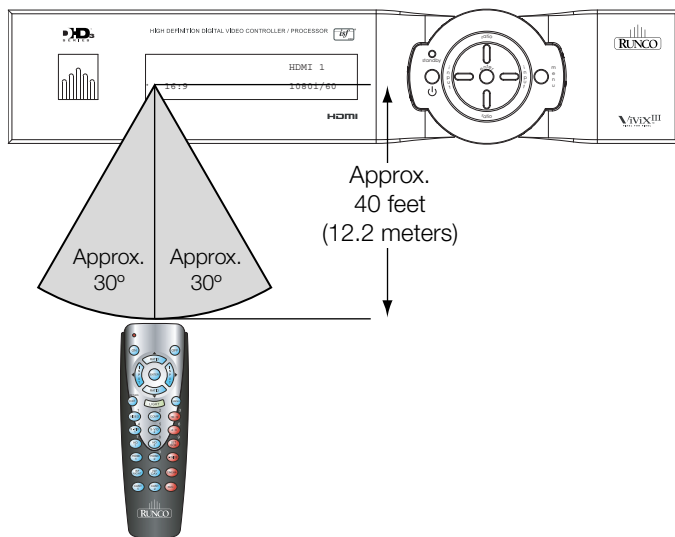

Figure 3-1. Available Range of the Remote Control

3.1 Remote Control

◀ Notes on Batteries

◀ Notes on Remote Control Operation

- Do not drop the remote control or expose it to moisture or high temperature.
- The remote control may malfunction under a fluorescent lamp. If that occurs, move the plasma display away from the fluorescent lamp.
- Make sure that there is nothing obstructing the infrared beam between the remote control and the IR receiver on the plasma display.



Note

The signal from the remote control can be reflected by walls or other surfaces.

- If the effective range of the remote control decreases, or it stops working, replace the batteries with new ones.
- Ambient conditions may possibly impede the operation of the remote control. If this happens, point the remote control at the plasma display and repeat the operation.

3.2 Quick Setup

Table 3-1 gives a quick overview of the CX-70DHD installation process. The sections following this one provide detailed instructions.



Note

Installation must be performed by a qualified custom video installation specialist.

Table 3-1. Installation Overview

Step	Procedure	For Details, refer to page...
1	Mount the CX-70DHD on a wall or table stand	19
2	Connect the DHD Controller to the CX-70DHD	21
3	Connect signal sources to the DHD Controller	23
4	Connect external controller to DHD Controller RS-232 port (optional)	29
5	Apply power to the CX-70DHD	33
6	If using the CX-70DHD with a computer, adjust computer display properties	33
7	Display calibration: adjust the following for each input and display mode (resolution and frame rate); save settings when finished: <ul style="list-style-type: none"> • Aspect ratio • Brightness • Contrast • Color level • Tint • Sharpness • White Balance 	40

Proper installation of your CX-70DHD will ensure the highest possible picture quality. Whether you are installing the CX-70DHD temporarily or permanently, you should take the following into account to ensure that it performs optimally.

In general, minimize or eliminate light sources directed at the display. Contrast ratio in your images will be noticeably reduced if light directly strikes the display, such as when a shaft of light from a window or floodlight falls on the image. Images may then appear washed out and less vibrant.

If you are mounting the CX-70DHD in an enclosure, leave sufficient space on all sides between it and surrounding objects, as shown in Figure 3-2. This allows heat to disperse, maintaining the proper operating temperature.

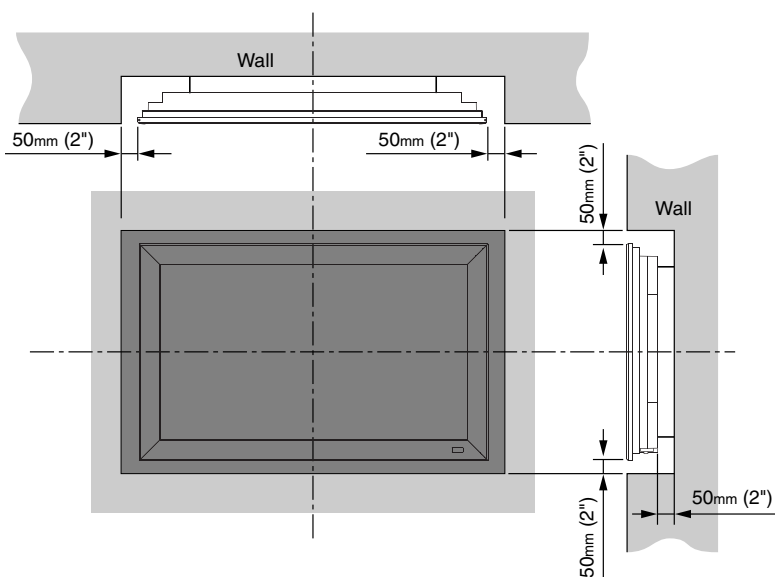

Figure 3-2. Ventilation Requirements for Enclosure Mounting

Due to its extraordinarily high level of video processing performance, the DHD Controller may distribute video signals with a perceptible level of audio latency. In order to easily solve this issue, Runco recommends using the DHD Controller with a high-quality audio receiver that has the ability to effectively synchronize audio and video signals.

Most mainstream audio receiver/switchers have the ability to synchronize the audio and video to the Advanced Television Systems Committee (ATSC) prescribed tolerances. According to the ATSC, the sound program should never lead the video program by more than 15 milliseconds, and should never lag behind the video program by more than 45 milliseconds.

3.3 Installation Considerations

◀ Ambient Light

◀ Ventilation

◀ Audio/Video Synchronization Issues

In addition, many A/V receivers introduce additional latency that needs to be compensated for during the installation. Table 3-2 shows the amount of possible audio latency given different signal input timings.

Table 3-2. Possible Audio Latency for Various Input/Output Timings

Input Timing	Possible Audio Latency (milliseconds)
480i	133
480p	83
576i	160
576p	100
720p/50	100
720p/60	83
1080i/25	160
1080i/30	133
1080p/24	67
1080p/50	80
1080p/60	67

- Other Considerations** ➤ Here are some other considerations and tips that can help improve your installation, avoid damage and prolong operating life:
- Keep the ambient temperature constant and below 35°C (95°F). Keep the display away from heating and/or air conditioning vents. Changes in temperature may cause drifts in the display circuitry, which may affect performance.
 - Keep the CX-70DHD away from devices that radiate electromagnetic energy such as motors and transformers. Common sources of these include slide projectors, speakers, power amplifiers and elevators.
 - Handle the unit carefully when installing or carrying it. Use the built-in handles; DO NOT touch or hold the screen face.
 - Set the unit away from heat, excessive dust, and direct sunlight.
 - Protect the inside of the unit from liquids and small metal objects. In case of accident, unplug the power cord and have it serviced by an authorized Service Center.
 - Do not hit or scratch the panel surface as this causes flaws on the surface of the screen.
 - For correct installation and mounting it is strongly recommended to use a trained, authorized dealer.
 - To avoid sulfurization, it is strongly recommended not to place the unit in a dressing room in a public bath or hot spring bath.

You can install the CX-70DHD either on a table or other flat surface (using the included table stand) or on a wall using the optional wall-mounting kit.

Before installing the wall mount or table stand, place the panel face down on a soft, flat surface. Place the protective sheet, which was wrapped around the panel when it was packaged, between the screen and your work surface to avoid scratching or otherwise damaging the screen surface.

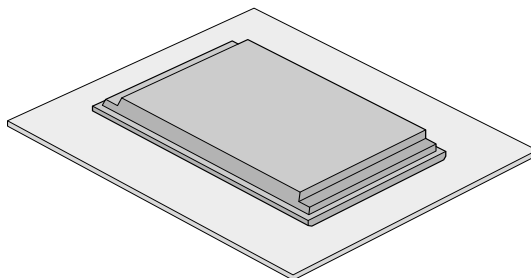

◀ **Mounting the CX-70DHD
on a Wall or Table Stand**

Table Stand Assembly: Figure 3-3 shows how to assemble the included table stand and attach it to the panel.

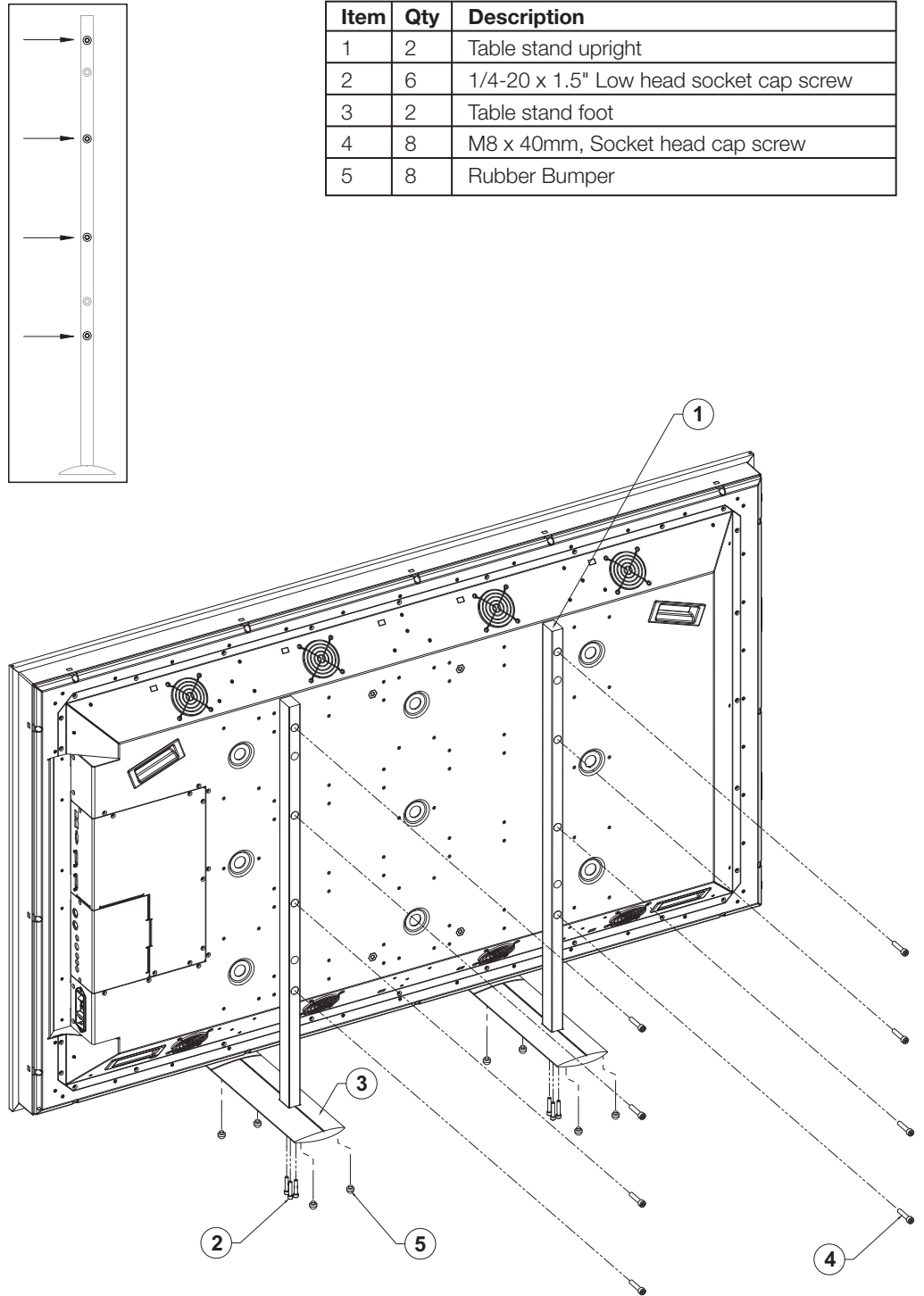

Figure 3-3. Assembling and Installing the Table Stand

If you choose to wall-mount the CX-70DHD, ensure that the wall-mount bracket is installed according to the instructions included with it. The wall must be capable of supporting a redundant weight factor five (5) times the weight of the display, or be reinforced.

Runco recommends that this be done by a custom installation specialist.

**Note**

*Use only a Runco-approved wall-mount kit or table stand that is specifically designed for your display. Refer to **Parts List** on page 4 for ordering information.*

Proceed as follows to connect the CX-70DHD to the DHD Controller, your video sources, external controller(s) – if present – and AC power.

When connecting your equipment:

- Turn off all equipment before making any connections.
- Use the correct signal cables for each source.
- Ensure that the cables are securely connected. Tighten the thumbscrews on connectors that have them.

Connect the DHD Controller to the CX-70DHD as shown in Figure 3-4 and described in the sections that follow.

3.4 Connections to the CX-70DHD and DHD Controller

◀ Connecting the CX-70DHD to the DHD Controller

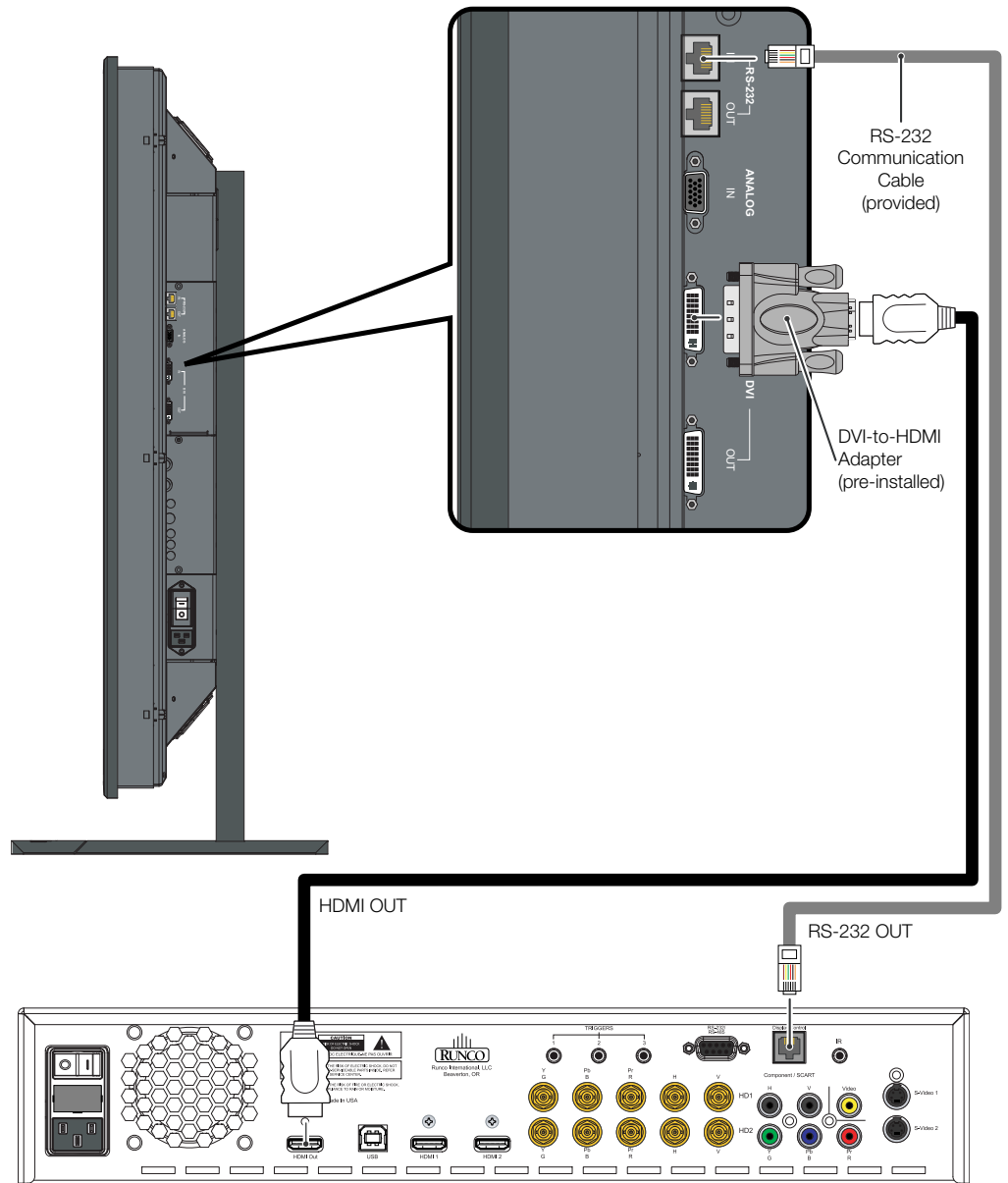
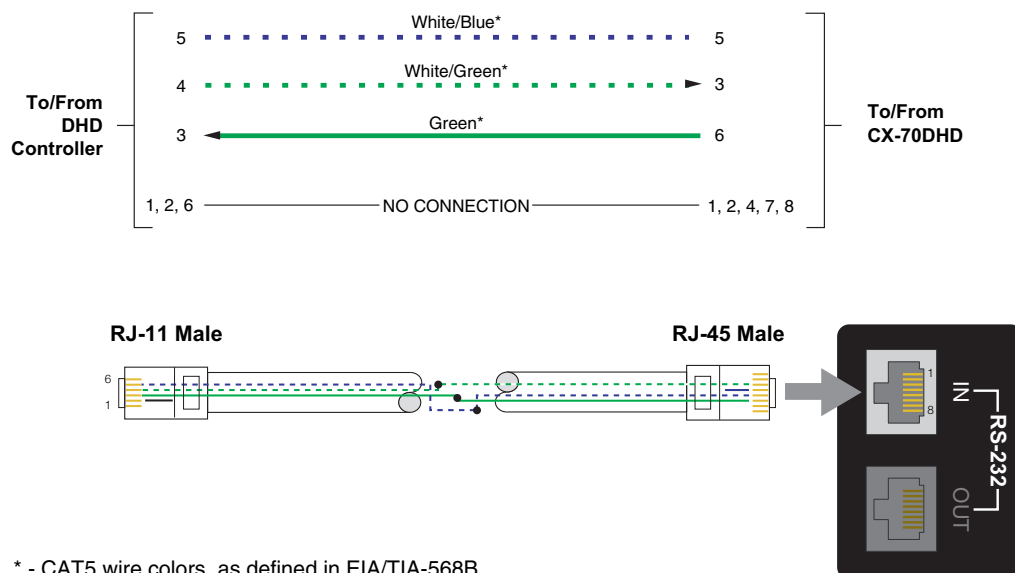

Figure 3-4. Connecting the CX-70DHD to the DHD Controller

Digital Video Connection: Connect the HDMI output from the DHD Controller to the **DVI IN** input on the CX-70DHD, using an HDMI-to-HDMI cable and the included, DVI-to-HDMI adapter.

RS-232 Connection: Connect the **Display Control** output from the DHD Controller to the **RS-232 IN** input on the CX-70DHD. Use a cable with an RJ11 plug at the DHD Controller end and an RJ-45 plug at the CX-70DHD end. (The CX-70DHD accessory kit includes such a cable.)

If you make your own cable, it **must** be wired as shown in Figure 3-5.



* - CAT5 wire colors, as defined in EIA/TIA-568B

Figure 3-5. RS-232 Connection from the DHD Controller to the CX-70DHD

Connect your video sources to the DHD Controller as shown and described in the sections that follow.

HDMI Source Connections: See Figure 3-6.

◀ **Connecting Source Components to the DHD Controller**



Tip

Use the HDMI inputs whenever possible. This ensures the highest video quality because the signal is carried in the digital domain throughout the entire signal path, from source component output into the display.



Note

You can also connect computers with DVI output to these inputs. Refer to **Supported Timings** on page 70 for a list of compatible input signals.

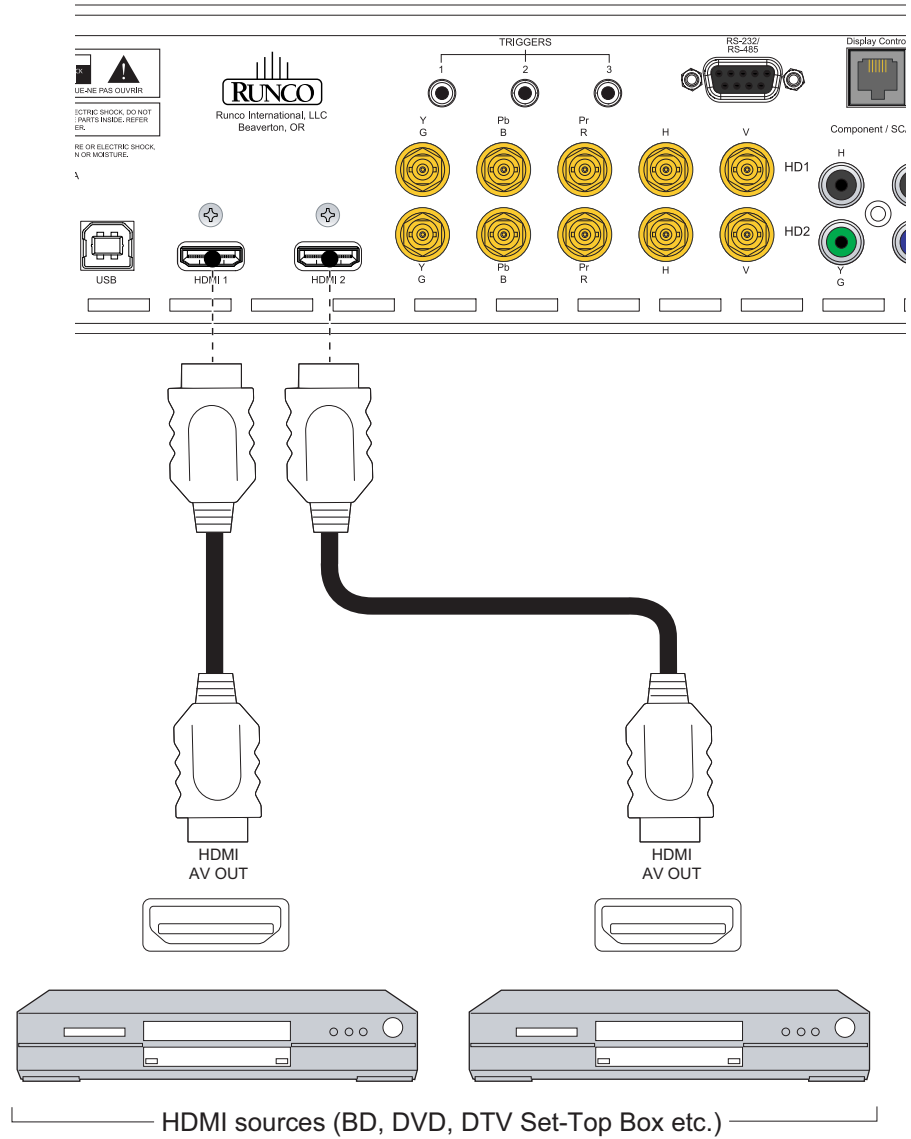

Figure 3-6. HDMI Source Connections

Component Video Source Connections: Connect your component video sources to the HD1, HD2 and/or Component/SCART inputs as shown in Figure 3-7.

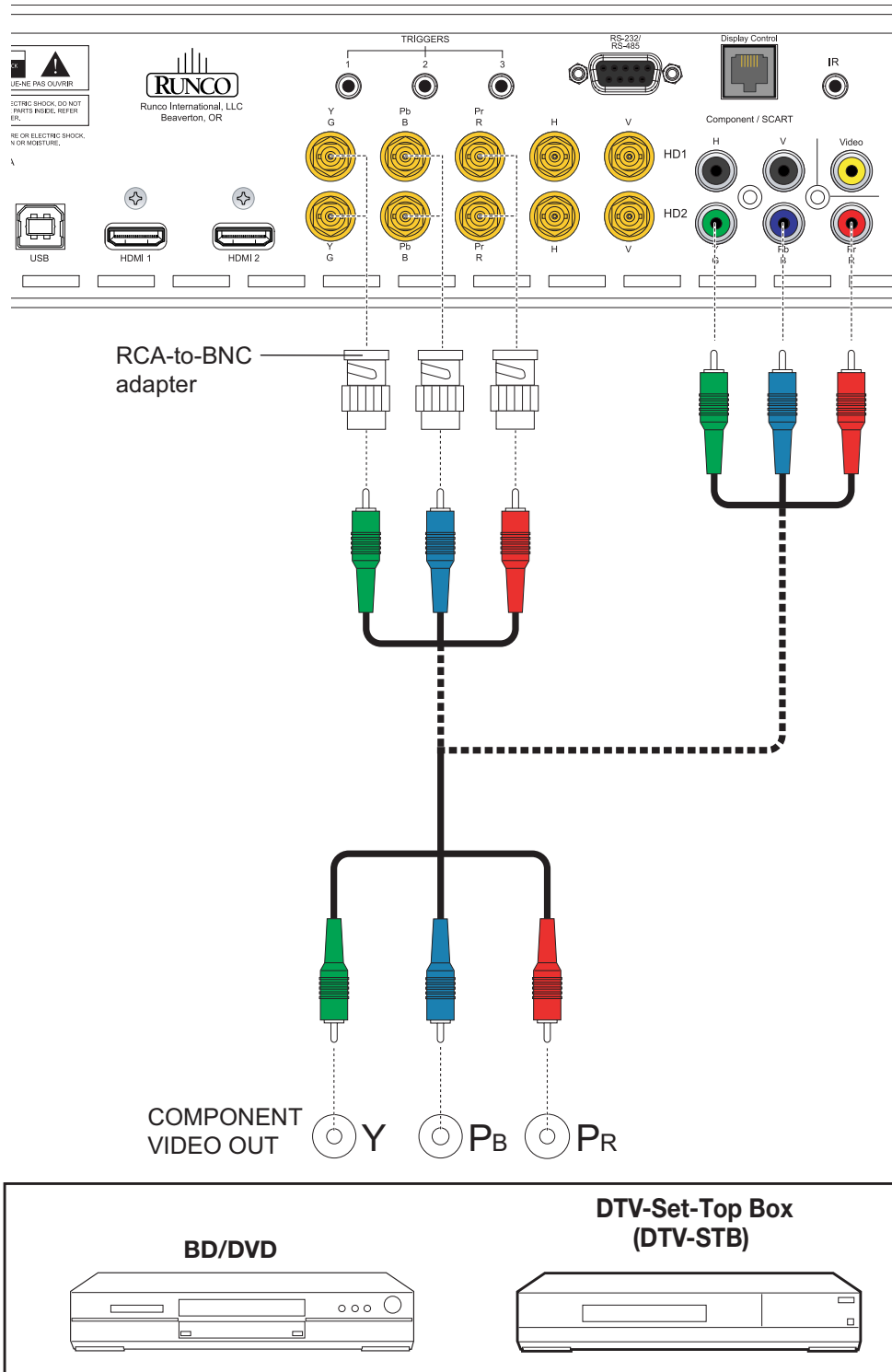

Figure 3-7. Component Video Source Connections

RGBHV Source Connections: Connect personal computers and/or other RGB sources to the HD1, HD2 and/or Component/SCART inputs as shown in Figure 3-8.

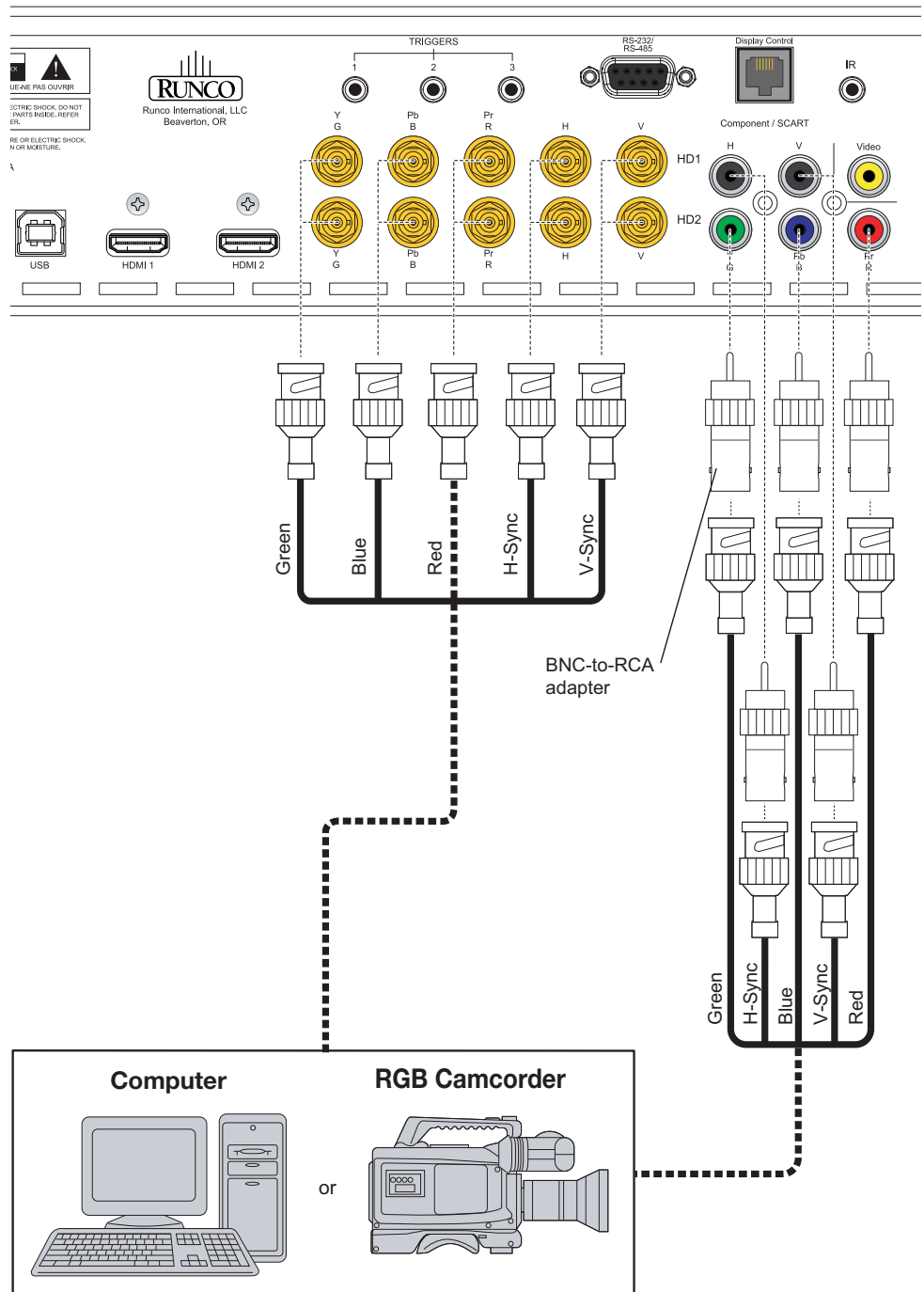

Figure 3-8. RGBHV Source Connections

SCART RGBS Source Connections: Connect the green, blue and red outputs from your SCART source to the Component/SCART input on the DHD Controller. Connect the sync output from your SCART source to the Video input on the DHD Controller. See Figure 3-9.

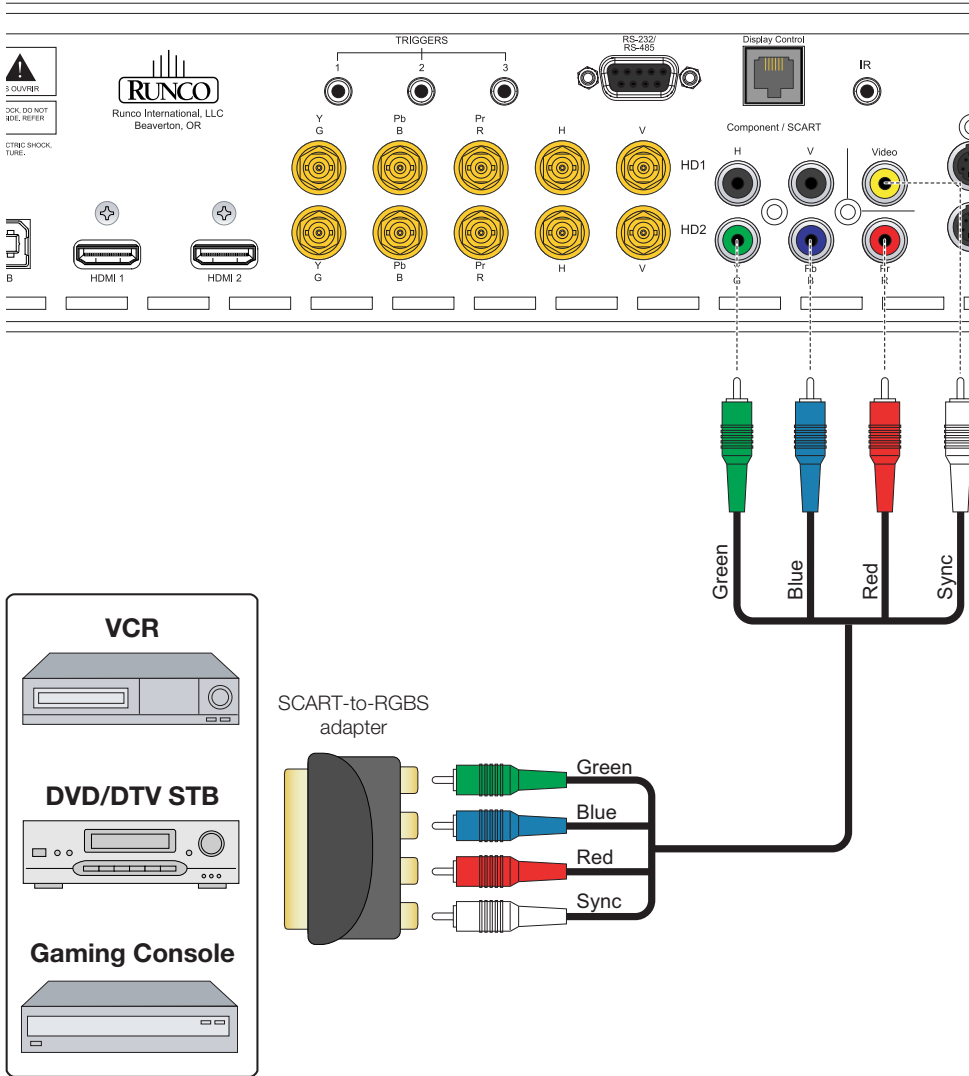

Figure 3-9. SCART RGBS Source Connections

Composite and S-Video Source Connections: See Figure 3-10.

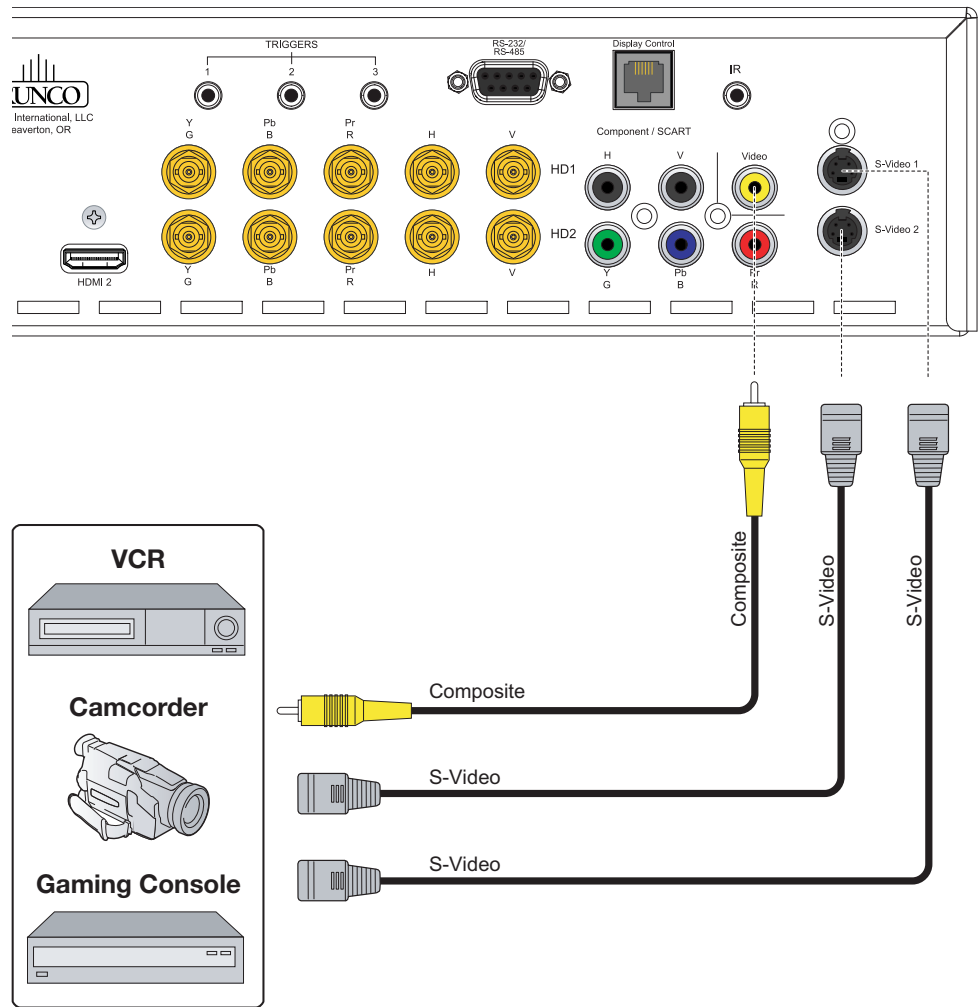

Figure 3-10. S-Video and Composite Video Source Connections

Use a straight-through, 9-pin RS-232 cable to connect a PC or control/automation system (if present) to the RS-232 port on the DHD Controller; see Figure 3-11.

◀ **RS-232 Controller Connection**

For more information about using this connection, refer to **External Control** on page 59.

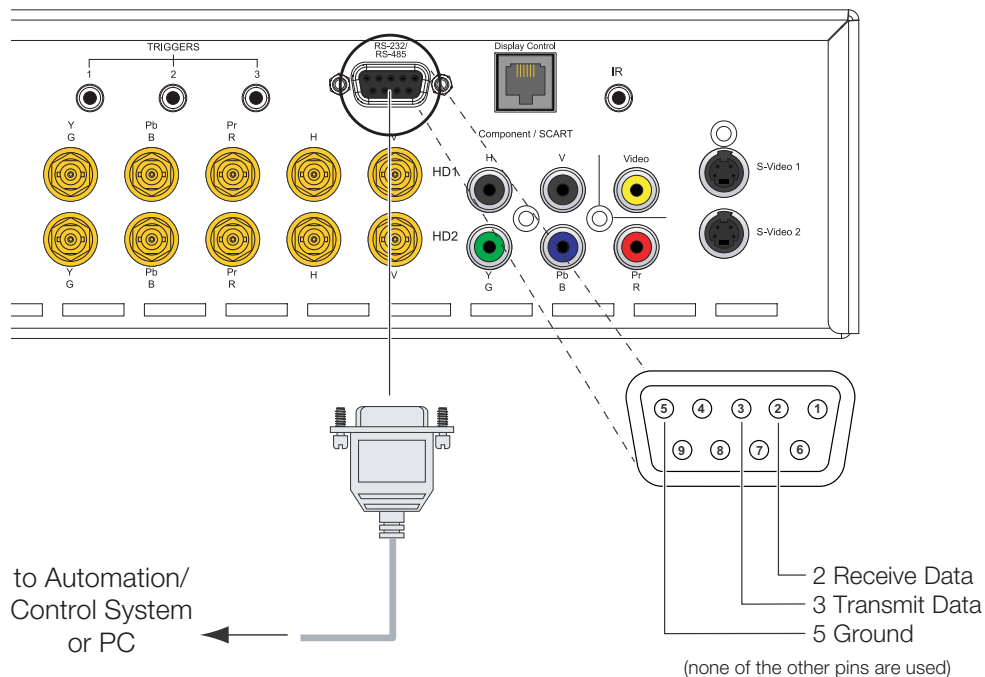

Figure 3-11. RS-232 Control System Connection

Connecting 12-volt Trigger Outputs to External Equipment

If your installation includes equipment that responds to 12-volt triggers, connect it to the 12-volt trigger outputs as shown in Figure 3-12.

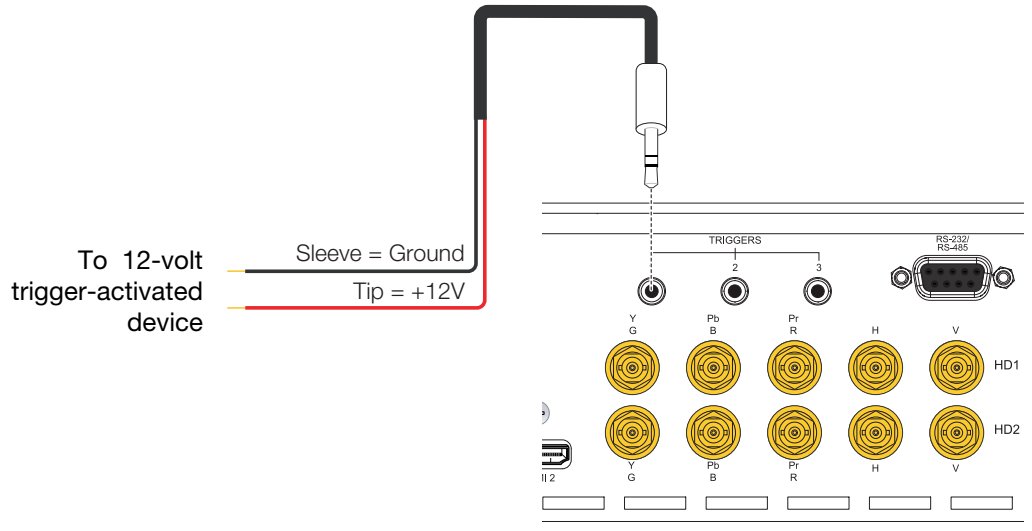

Figure 3-12. Connecting 12-volt Trigger Outputs

If infrared signals from the remote control cannot reach the DHD Controller due to excessive distance or obstructions such as walls or cabinet doors, you can connect an external IR receiver to the DHD Controller to extend the range of the remote control. See Figure 3-13.

◀ **Connecting an External IR Receiver to the DHD Controller**

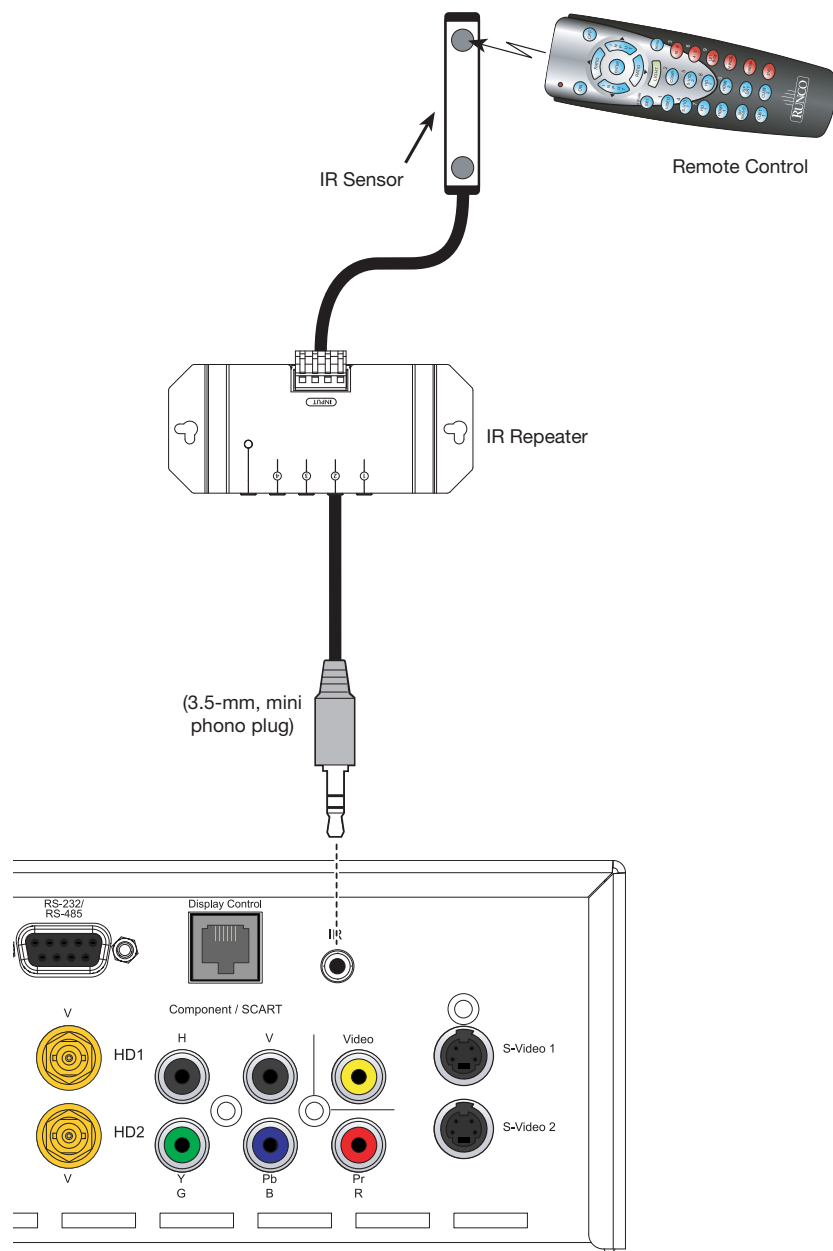

Figure 3-13. External IR Receiver Connection

- Connecting AC Power** ➤ Plug the female end of the power cord into the AC receptacle on the rear of the CX-70DHD. Connect the other end to your AC power source.



Similarly connect the DHD Controller to a nearby AC outlet.



4. Operation

1. Turn on your source components.
2. Press the main power switch on the CX-70DHD (see Figure 2-1). The standby/on indicator lights red.
3. Set the main power switch at the rear of the DHD Controller (see Figure 2-4) to the “on” position.
4. Press the **ON** button on the remote control to turn on the DHD Controller and CX-70DHD (or press the power button on the front of the DHD Controller). The power indicator on the DHD Controller lights solid blue.
5. After a brief warm-up period, the CX-70DHD will display an image.

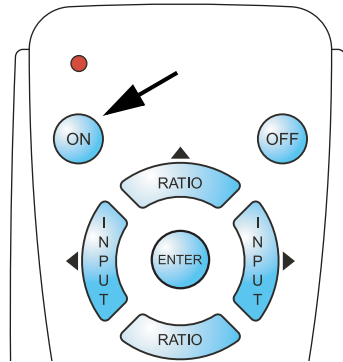

4.1 Turning on the Power

To maximize image quality when using the CX-70DHD with a personal computer, you may need to adjust the display properties of your computer's video card. To do this on a Microsoft® Windows®-based PC:

1. Choose Settings from the Windows Start Menu and click on “Control Panel.”

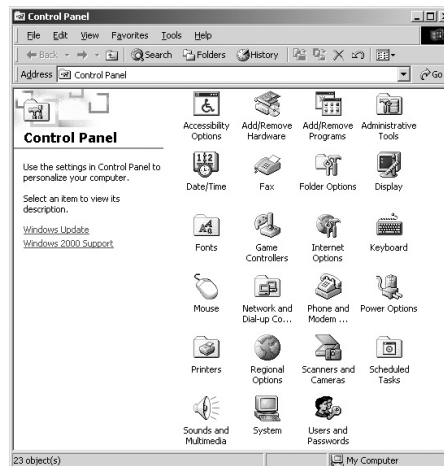

4.2 Setting the Computer Display Properties

2. Double click on the **Display** icon.
3. Click the **Settings** tab on the display dialog box.
4. Set the **Screen area** to 1024x768 pixels.

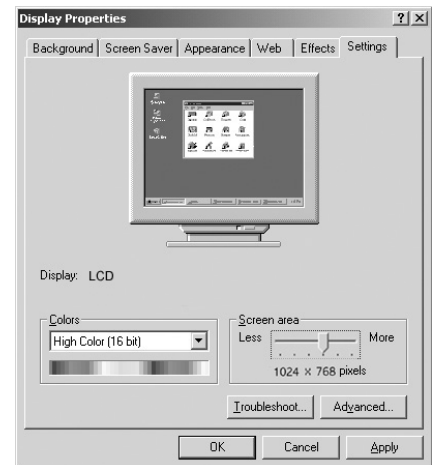

5. Click the **Advanced** button and click the **Monitor** tab on the dialog box. Set the **Refresh Frequency** to 60Hz and click **OK**.



Note

1. The native resolution of the CX-70DHD is 1920 x 1080. Other horizontal or vertical resolutions may be scaled upward or downward to fit the display.

2. With most computers, you can get the best picture at 1024 x 768 @ 60Hz.



WARNING

To prevent image retention (burn) on your display, **ALWAYS** use a screen saver and set it to the shortest possible time.

To display the Main Menu, press the **MENU** button on the remote control (Figure 2-5) or DHD Controller front panel (Figure 2-3).

To select a menu item, use the **▲** and **▼** buttons on the remote control or DHD Controller front panel to highlight it. Then, to confirm your selection, press **ENTER** on the remote control or DHD Controller front panel.

The CX-70DHD OSD menus are arranged hierarchically, as shown in Figure 4-1. Depending on the selected input source and signal characteristics, some menu options may not be available.

4.3 Using the On-Screen Menus

Input Source	Composite
	S-Video 1
	S-Video 2
	Component
	HD1
	HD2
	SCART
	HDMI 1 HDMI 2
Aspect Ratio	16:9
	4:3
	Letterbox
	VirtualWide
	Cinema
	Virtual Cinema
Picture	Native
	Brightness
	Contrast
	Color
	Tint
	Sharpness
Input Position	Noise Filter
	Left/Right
	Up/Down
	Width
	Height
	Overscan
	Overscan Mode (Zoom/Crop)
	Phase (RGB/Component/SCART signals only)
	Tracking (RGB/Component/SCART signals only)
	Memory Presets
Recall ISF Day	
Recall/Save Custom 1	
Recall/Save Custom 2	
Reset Custom 1 and Custom 2 to Factory Default	
Information	Signal
	System
	Field Service
	Manufacturing

Calibration	Display Color	Gain	-100, -99... 0 ... 99, 100
		Offset	(Red, Green, Blue)
		Gamma	1.85, 1.90, 1.95 ... 2.20 ... 2.55, 2.60
		Color Temp	Simple (3200K, 5500K or 6500K)
		Backlight	1 , 2, 3 ... 10
	Input Image	Brightness	-50, -49 ... 0 ... 49, 50
		Contrast	
		Color	
		Tint	
	Input Color	Sharpness	-32, -31... 0 ... 31, 32 (HD 1, HD 2 and Component inputs only)
		Gain	
		Offset	
		Chroma Delay	
	Save ISF Night Save ISF Day	Noise Filter	0 , 1, 2 ... 63
		Back / Confirm	
		Copy/Paste	Copy Settings Paste Settings
	Output Shift	Left/Right	-50, -49 ... 0 ... 49, 50
		Up/Down	
		Width	
	Splash Configure	Height	-50, -49, 48 ... 0
Owner Name			
ISF Calibrated			
ISF Other			
OSD Position	Splash Timer	5, 6, 7 ... 15 ... 59, 60	
	Splash Enable	On/Off	
	Hor. / Ver.	0 , 1, 2 ... 100	

Note: Default settings appear in **bold type**.

Figure 4-1. CX-70DHD OSD Menu Structure

Service	Test Video	Color Bars 1	
		Color Bars 2	
		Focus	
		Grey Bars	
	Input Names	Rename/Restore	
	Remote Control	Remote Code	00, 01, 02 ... 17 ... 31
		COMP Key Source	Component or SCART
	Display Device - Configure	Installation	Picture Orientation: Floor Front, Ceiling Front, Floor Rear or Ceiling Rear
		Diagnostics	White, Red, Green, Blue, Yellow, Cyan, Magenta
	Color Space	Auto , REC601, REC709, RGB-PC or RGB-Video	(Not available on S-Video or Composite video inputs)
	Triggers	1 / 2 / 3	
	Miscellaneous	Language	English, Français, Deutsch, Italiano, Español, Svenska, Traditional Chinese, Simplified Chinese, Português or Russian
		OSD Timer	0 (no timeout) or 5, 6, 7 ... 15 ... 60 sec.
		OSD Messages	On / Off
		Blank Screen Color	Red/Green/Blue = 0 , 1, 2, 3 ... 255
		Sidebar Color	
		Film Mode (SD sources only)	On / Off
	CUE (Chroma Upsampling Error)	On / Off	
	Sync Threshold	0, 1, 2 ... 15	(HD 1, HD 2 and Component inputs only)
	HDMI EDID Extension	HDMI 1 / HDMI 2	On / Off
	Front Panel Brightness	Logo LED	0 (off), 1, 2 ... 31
		Standby LED	On / Off
		LCD	0 (off), 1, 2, 3 or 4
System Reset			

Note: Default settings appear in **bold type**.

Figure 4-1. CX-70DHD OSD Menu Structure (continued)

Main Menu ➤ The Main Menu is the starting point for accessing all CX-70DHD functions. (You must enter a passcode to access the Calibration and Service menus.)

Runco Video
Input Source
Aspect Ratio
Picture
Input Position
Memory Presets
Information
Calibration
Service

From the Main Menu, select Input Source to choose a video signal source.

The active source is indicated by an arrow (➡) to its left; in this example, Composite is the active source.

◀ **Input Source**

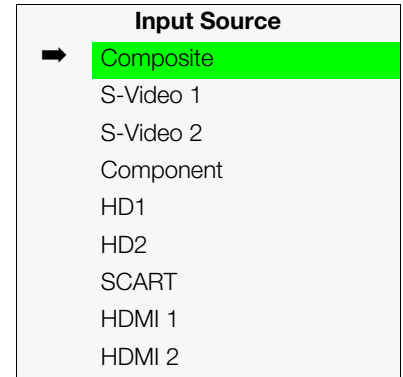

To change the aspect ratio (size and shape) of the projected image, select Aspect Ratio from the Main Menu and press **ENTER**. Select the appropriate aspect ratio for your screen size and the type of program material being viewed; refer to Table 4-1.

The currently-selected aspect ratio is indicated by a “☒” to its left; in this example, 16:9 is selected.

Note that some aspect ratios are unavailable and/or not useful with certain types of source material. The optimal setting depends on a number of factors, such as:

- The aspect ratio of the source material, as broadcast or encoded on the playback medium.
- The “display type” (16:9 or 4:3) and output resolution settings at the source component. Most modern DVD/BD players and set-top boxes have such controls.
- Viewer preference (original aspect ratio with “black bars,” or a full-screen presentation with some distortion or cropping).

◀ **Aspect Ratio**

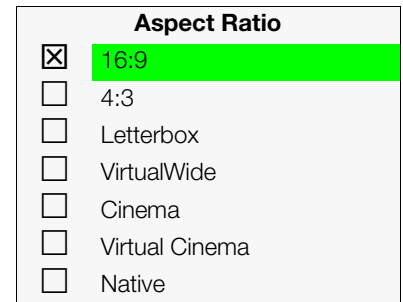

Note

The aspect ratio selection is automatically saved for each input and resolution.

Table 4-1. Aspect Ratio Settings



Aspect Ratio	Remote Control Key	Description	
16:9	16:9	 <p>16:9 Image on 16:9 Screen (Display)</p> <p>4:3 Image, stretched to fill 16:9 Screen (Display)</p>	<p>Select 16:9 to view 16:9 DVDs and HDTV programs in their native aspect ratio.</p> <p>4:3 images are stretched horizontally to fit a 16:9 screen.</p>
4:3	4:3	 <p>4:3 Image on 16:9 Screen (Display)</p>	<p>4:3 scales the input signal to fit in the center of the 16:9 screen. 4:3 is the aspect ratio used by computer monitors, standard television programming and most VHS video cassettes.</p>
Letterbox	LBOX	 <p>4:3 Image on 16:9 Display (Letterbox aspect ratio)</p>	<p>Letterbox mode scales (zooms in on) a 4:3 image linearly (by the same amount on all sides) to fill a 16:9 display. Letterbox is best suited for viewing LaserDisc movies or non-anamorphic DVDs on a 16:9 screen.</p>
VirtualWide	VWIDE	 <p>4:3 Image on 16:9 Screen (Display)</p> <p>4:3 Image on 16:9 Screen with VirtualWide</p>	<p>VirtualWide scales a 4:3 image NON-linearly (more on the sides than in the center) to fit a 16:9 screen.</p>

Table 4-1. Aspect Ratio Settings (continued)

Aspect Ratio	Remote Control Key	Description	
Cinema	CINEMA	 <p>2.35:1 Image on 16:9 Screen</p>	<p>Select Cinema to view 2.35:1 source material on a 16:9 screen. The upper and lower portions of the screen are masked, but the geometry of the active image area is not changed.</p>
Virtual Cinema	SVC	 <p>2.35:1 Image on 16:9 Screen</p>	<p>A 2.35:1 image is stretched anamorphically in both directions to fill a 16:9 display area.</p>
		 <p>2.35:1 Image on 16:9 Screen with Virtual Cinema</p>	<p>The 2.35:1 image is cropped on all sides.</p>
Native	(none)	 <p>1080i HDTV Image</p>	<p>Select Native to display the source signal in its native resolution, centered in the display area with no re-sizing or overscan.</p>
		 <p>720p HDTV Image</p>	<p>This means, for example, that 720p HDTV programs will display with unused pixels on all sides: 320 on the left and right sides and 180 above and below.</p> <p>With SDTV and EDTV sources, the CX-70DHD scales the image horizontally to achieve a 16:9 aspect ratio.</p>

Picture ➤

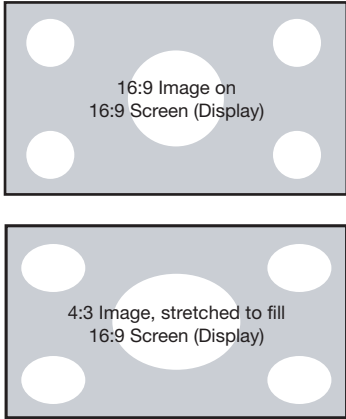
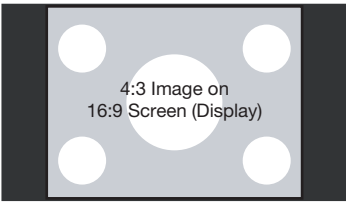
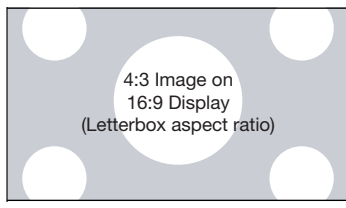
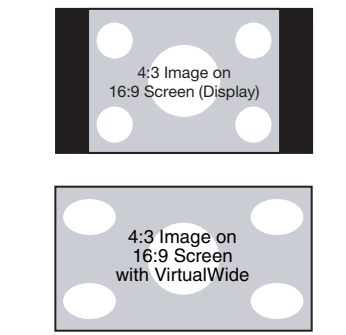
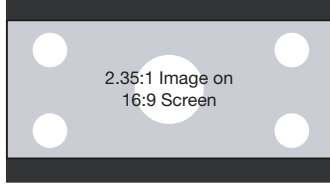
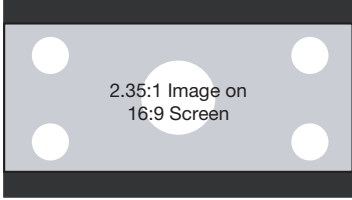
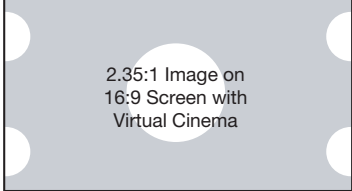
Picture
Brightness
Contrast
Color
Tint
Sharpness
Noise Filter

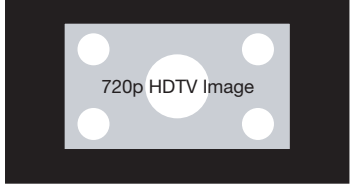
Use the controls in the Picture Menu to calibrate your CX-70DHD for optimum picture quality.

The CX-70DHD has been designed to incorporate setup and calibration standards established by the Imaging Science Foundation (ISF). The ISF has developed carefully crafted, industry-recognized standards for optimal video performance and has implemented a training program for technicians and installers to use these standards to obtain optimal picture quality from Runco video display devices. Accordingly, Runco recommends that setup and calibration be performed by an ISF certified installation technician.

All signal types require separate processing. Therefore, you need to calibrate each DHD Controller input separately.



Note

*When you change a picture quality setting, save the change to a preset afterwards. Otherwise, the change will be lost when a different input is selected. (Picture quality settings are saved for each input separately.) For information about saving settings, refer to **Memory Presets** on page 47.*

Although it may be possible to obtain satisfactory picture quality using the naked eye and regular program material, Runco recommends using an external test pattern source (Ovation Multimedia, Digital Video Essentials or AVIA test DVD or equivalent) for best results.

Connect your test pattern source to the input that you are calibrating and proceed as follows. **Perform the adjustments in the order listed here.**

Brightness: On your external test pattern source, select a PLUGE pattern. (PLUGE is an acronym for “Picture Line-Up Generation Equipment.”) Figure 4-2 shows a typical PLUGE pattern.

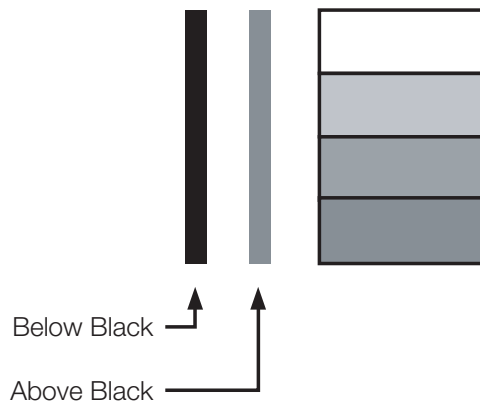

Figure 4-2. Typical PLUGE Pattern for Adjusting Brightness

PLUGE patterns vary but generally consist of some combination of black, white and gray areas against a black background. The example above includes two vertical bars and four shaded boxes.

Select Brightness from the Picture menu and press **ENTER**. Adjust the brightness so that:

- The darkest black bars disappear into the background.
- The dark gray areas are barely visible.
- The lighter gray areas are clearly visible.
- The white areas are a comfortable level of true white.
- The image contains only black, gray and white (no color).

Contrast: On your external test pattern source, select a stepped, gray-bar pattern like the one shown in Figure 4-3.

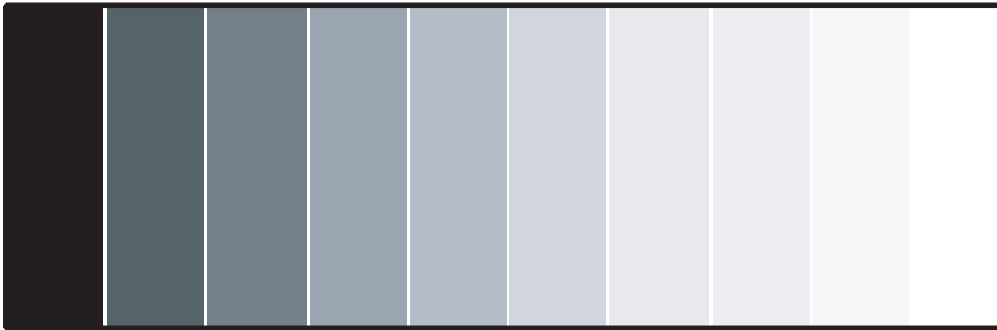

Figure 4-3. Typical Gray Bar Pattern for Adjusting Contrast

Select Contrast and press **ENTER**. Adjust the contrast to a point just below which the white rectangle starts to increase in size.



Brightness and contrast controls are interactive. A change to one may require a subtle change to the other in order to achieve the optimum setting.

Color Saturation: On your external test pattern source, select a color bar pattern like the one shown in Figure 4-4.

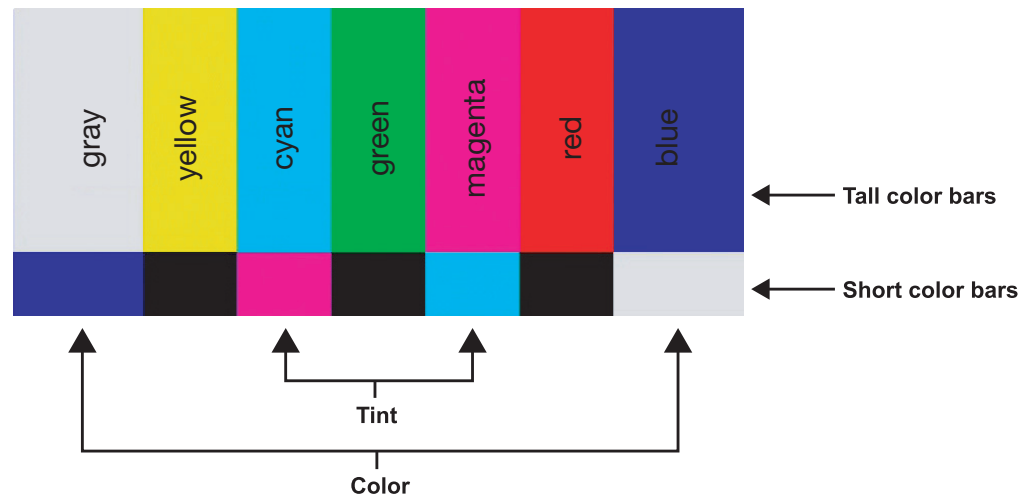
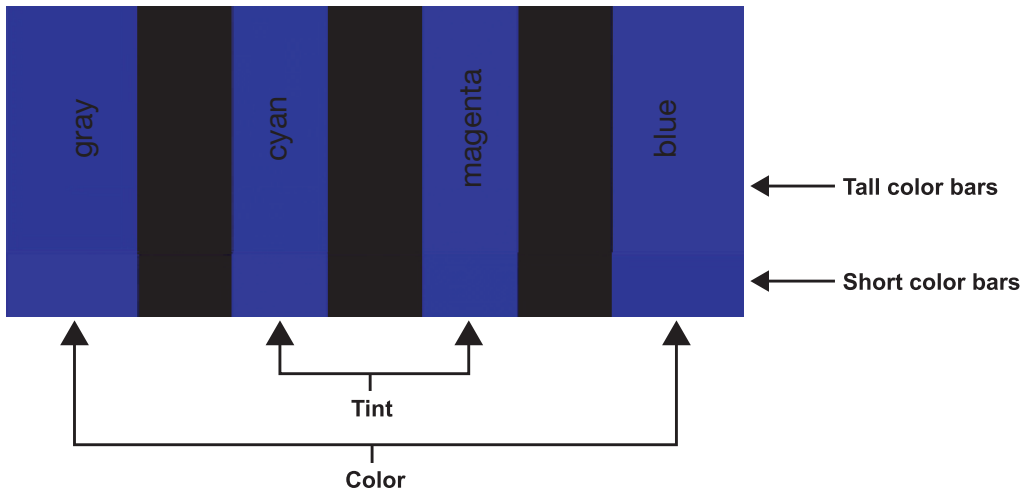

Figure 4-4. Typical Color Bar Pattern for Adjusting Color Saturation and Tint

1. Press the **MENU** button on the remote control or DHD Controller front panel.
2. Select Service from the Main Menu and press **ENTER**.
3. Enter the Service menu passcode.
4. Select Display Device from the Service menu and press **ENTER**.
5. Press **ENTER** again to select Configure.
6. Select Diagnostics and press **ENTER**.
7. Select Blue from the Diagnostics menu, then press **ENTER** to display only the blue color channel.
8. Press **RETURN** (or **MENU**) repeatedly to return to the Main Menu.
9. Select Picture from the Main Menu and press **ENTER**.
10. Select Color from the Picture menu and press **ENTER**.

11. Adjust the color saturation level until the outermost (gray and blue) color bars appear to be a single shade of blue:



Tint: Tint or “hue” is essentially the ratio of red to green in the color portion of the image. When tint is decreased, the image appears redder; when it is increased the image appears greener.

To adjust the tint, enable “blue only” display mode in the Diagnostics menu, as you would for adjusting color saturation (refer to the previous section, **Color Saturation**).

Select Tint from the Picture menu and press **ENTER**. Adjust the tint level until the cyan and magenta color bars (on either side of the green bar) appear to be a single shade of blue.



Note

Like the brightness and contrast controls, the color and tint controls are interactive. A change to one may require a subtle change to the other in order to achieve the optimum setting.

Sharpness: “Sharpness” is the amount of high-frequency detail in the image. To adjust sharpness, select Sharpness from the Picture menu and press **ENTER**. On your external test pattern source, select a pattern like the one shown in Figure 4-5. Adjust as needed, looking for white edges around the transitions from black to gray and differently-sized lines in the “sweep” patterns at the top and bottom. Lower the sharpness setting to eliminate them.

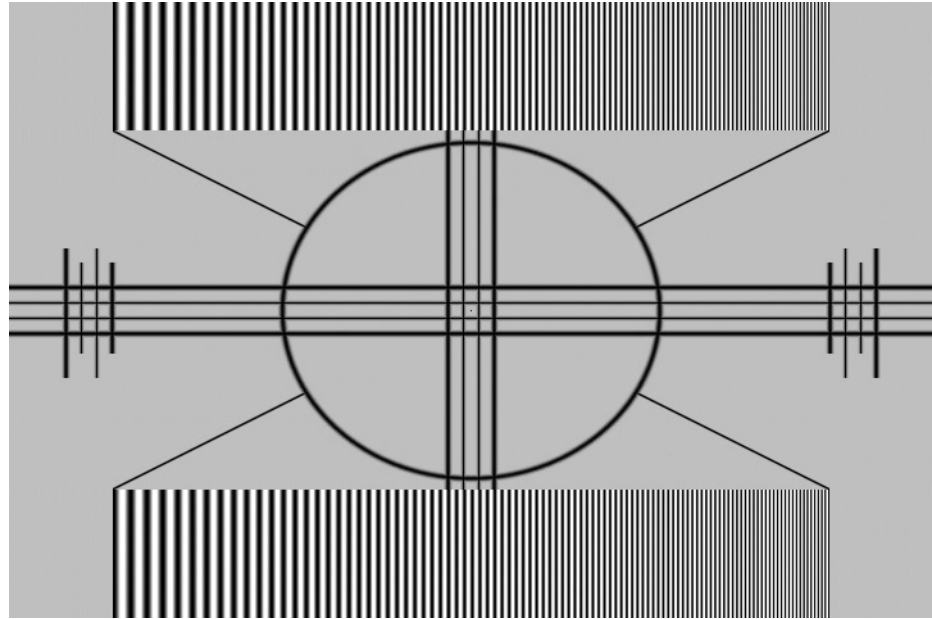

Figure 4-5. Typical Test Pattern for Adjusting Sharpness

Noise Filter: To apply noise filtering to the input signal, select Noise Filter from the Picture menu. The Noise Filter is useful for clearing up noisy images from 480i video sources.

Use the left- or right-arrow buttons to select the desired amount of noise reduction, keeping in mind that higher settings (which reduce high frequencies) may also “soften” the image.

Use the controls in the Input Position Menu to fine-tune the aspect ratio and image position for the current source.



Note

The input position settings are automatically saved for each input and resolution.

Left/Right: Select Left/Right from the Input Position menu to shift the projected image horizontally. Press ► to shift the image to the right; press ◀ to shift it to the left.

Up/Down: Select Up/Down from the Input Position menu to shift the projected image vertically. Press ► to shift the image upward; press ◀ to shift it downward.

Width: Select Width from the Input Position menu to change the projected image width. Press ► to increase the width; press ◀ to decrease it.

Height: Select Height from the Input Position menu to change the projected image height. Press ► to increase the height; press ◀ to decrease it.

Overscan/Overscan Mode: Overscan pushes the outside edge of the active picture area of the video signal out beyond the edge of the display area.

Some television programs are produced based on the assumption that older television sets may not display the outer edges of the broadcast picture area. Overscan effectively trims away these inactive, outer edges and enlarges the remaining portion of the image to fill the display area.

For HDTV, DVDs and other video sources, Overscan is generally not necessary or desirable.

This control defines the amount of overscan applied to the image. The range is from 0 to 20. There are two overscan modes:

- In **Crop** mode, each increment adds a mask at the top, bottom, left and right edges of the source image equal to 0.5% of the displayed horizontal resolution (1% total). A setting of 10, for example, crops the image 5% on all sides or 10% total.
- In **Zoom** mode, each increment adds a factor to the scaling of the source image so that the vertical and horizontal resolutions are 100% plus 1% increments of the size determined by the aspect ratio function. A setting of 10, for example, zooms in on the image 5% on all sides or 10% total.

Figure 4-6 illustrates the effect of each overscan mode setting.

◀ **Input Position**

Input Position
Left/Right
Up/Down
Width
Height
Overscan
Overscan Mode
Phase
Tracking

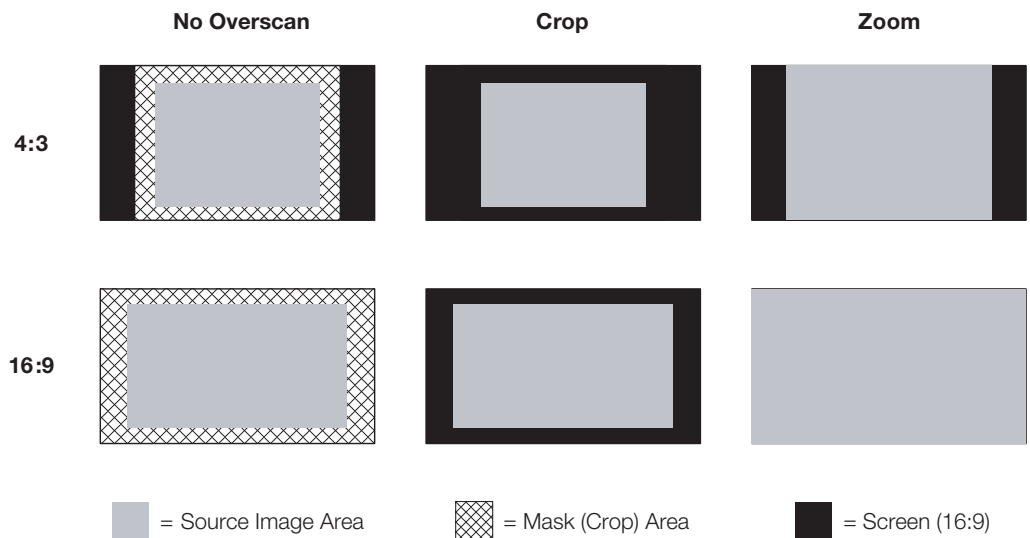

Figure 4-6. Overscan Modes

Phase (RGB, Component or SCART sources): This control adjusts the phase of the pixel sampling clock relative to the incoming signal. Adjust the phase when an RGB, Component or SCART image still shows shimmer or “noise” after Tracking has been optimized.



Tip

Adjust the Phase after adjusting Tracking (see below).

For best results, use a good test pattern such as a smooth gray consisting of a clear pattern of black and white pixels, or a similar “half on, half off” graphic image. Adjust the slider until the image stabilizes and each pixel is clearly defined. You may notice that you can stabilize the image at more than one point. Use either setting in such cases.

Tracking (RGB, Component or SCART sources): Tracking determines the frequency of the pixel sampling clock, indicated by the number of incoming pixels per line, so that all pixels generated by a particular source are sampled.

Steady flickering or several soft vertical stripes or bands across the entire image indicates poor pixel tracking. Proper pixel tracking helps ensure that the image quality is consistent across the screen, that aspect ratio is maintained and that pixel phase (see above) can be optimized.

For each input, the CX-70DHD lets you save image quality settings as presets that you can recall at a later time. You can create up to four presets per input and display mode (resolution and frame rate).

The DHD Controller stores the following display modes in each memory preset:

- 480i
- 480p
- 576i
- 576p
- 720p/24 Hz
- 720p/25 Hz
- 720p/30 Hz
- 720p/50 Hz
- 720p/60 Hz
- 1080i/50 Hz
- 1080i/50 Hz (Australia)
- 1080i/60 Hz
- 1080p/24 Hz
- 1080p/25 Hz
- 1080p/30 Hz
- 1080p/50 Hz
- 1080p/60 Hz

Use the Memory Presets menu to recall saved image presets, or to save image settings in the “Custom 1” or “Custom 2” memory location. The currently-selected preset is indicated by a “➡” to its left; in the example shown here, ISF Night is selected.

You should save changes to any of the following settings to a preset; otherwise they will be lost when a new input source or resolution is selected:

- Brightness
- Contrast
- Color saturation
- Tint
- Sharpness
- Gamma
- Lamp Settings
- Color temperature and white balance

To select a memory preset, press ▲ or ▼ to highlight it and press **ENTER**.

To save the settings for the current input and display mode to the Custom 1 or Custom 2 memory preset, select it, press ◀ or ▶ to highlight Save and press **ENTER**.

◀ **Memory Presets**

Memory Presets		
➡	ISF Night	
	ISF Day	
	Custom 1	Save Reset
	Custom 2	Save Reset



Note

*To save the settings for the current input and display mode to the ISF Night or ISF Day memory preset, select Save ISF Night or Save ISF Day from the Calibration menu (refer to **Save ISF Night/Save ISF Day** on page 50).*

To reset the Custom 1 or Custom 2 memory preset to its factory-default state, select it, press ◀ or ▶ to highlight Reset and press **ENTER**.

Information ➤

Information
Signal
System
Field Service
Manufacturing

Signal / System: Select Information from the Main Menu, then choose either Signal or System to display information about the current input signal (resolution, frequency, type et cetera) and installed firmware versions, as well as other information that uniquely identifies your DHD Controller and display device.

Should you ever need to contact Runco Technical Support, this information will help them answer your questions or resolve product performance issues.

Signal	
Input Source	HDMI 1
Signal Format	1080p/60
Input Resolution	1920x1080
Vertical Freq	59.94 Hz
Horizontal Freq	67.500 kHz
Pixel Clock	148.500 MHz
Color Space	REC709
Sync Type	Separate
Memory Preset	ISF Night

System	
Model	DHD3
Display Name	CX-70DHD
Output Resolution	1920x1080
Serial Number	00000000
Boot Version	3.0
Firmware Version	3.4
Micro Version	3.3

Field Service / Manufacturing: The Field Service and Manufacturing menus are password-protected and intended for use only by Runco service personnel and factory technicians.

Calibration ➤

Calibration
ISF Settings
Display Color
Input Image
Input Color
Save ISF Night
Save ISF Day
Copy/Paste
Output Shift
Splash Configure
OSD Position

Use the Calibration menu to perform advanced picture quality adjustments. **This menu should be used by ISF-certified technicians only.**



Note

You must enter a passcode to access the Calibration menu.

To recall the ISF Night or ISF Day settings, select “ISF Night” or “ISF Day” from the Memory Presets menu (see page 47) or use the corresponding remote control buttons.

Display Color: Use the Display Color settings to adjust the color balance at the DHD Controller output. These settings are saved independently for each input and display mode.

- **Gain:** Use the Gain controls to correct color imbalances in the bright areas of the image. A good way to do this is to use a test pattern consisting mostly of solid white areas, such as an 80 IRE “window” pattern. If the white areas contain traces of red (Pr), green (Y) or blue (Pr), decrease the Gain for that color.
- **Offset:** Use the Offset controls to correct color imbalances in the dark areas of the image. A good way to do this is to use a test pattern consisting mostly of dark gray areas, such as a 30 IRE “window” pattern. If the gray areas contain traces of red (Pr), green (Y) or blue (Pr), decrease the Offset for that color.

- **Gamma:** Select Gamma from the Display Color menu to choose a de-gamma curve. Used correctly, the Gamma control can improve contrast while maintaining good details for blacks and whites. If excess ambient light washes out the image and it becomes difficult or impossible to see details in dark areas, lower the gamma setting to compensate. This improves contrast while maintaining good details for blacks. Conversely, if the image is washed out and unnatural, with excessive detail in black areas, increase the setting.
- **Color Temp:** Select Color Temp from the Display Color menu to adjust the color temperature. Color temperature establishes the “color of gray” by adjusting the 75% white point to various color points.

What are “color points?” A “color point” is an x/y coordinate pair that defines a color’s location on the standard CIE chromaticity graph, shown in Figure 4-7. (CIE stands for “Commission Internationale de l’Éclairage” (International Commission on Illumination), the organization responsible for color measurement and management standards.)

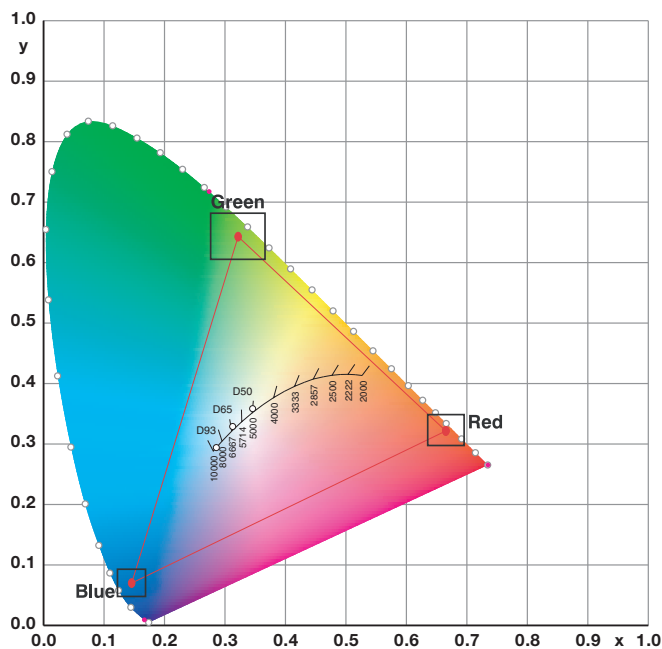

Figure 4-7. CIE 1931 Chromaticity Diagram

- **Simple:** Select Simple mode from the Color Temp menu (with the CX-70DHD, this is the only choice) to choose one of three color temperature presets: 3200K, 5500K or 6500K. The default setting, 6500K, is appropriate for most situations. Higher settings produce a “bluer” picture; lower ones impart a reddish hue to the image.

Table 4-2 lists the x- and y-coordinates for each color temperature preset.

Table 4-2. Color Temperature Presets and Associated Color Points

Color Temperature Preset	Associated x/y Values	
	x	y
3200K	0.423	0.404
5500K	0.332	0.348
6500K	0.313	0.329

- **Backlight:** The Backlight control changes the apparent brightness of the displayed image. Its effect is similar to that of a lamp intensity control on a projector. Use a higher setting for rooms with a lot of ambient light. Use a lower setting for more “theater-like” viewing conditions (little or no ambient light).



Tip

To prolong the life of the display, set the Backlight only as high as is necessary to produce the desired brightness.

Input Image: The Input Image controls are functionally similar to those in the Picture menu (refer to page 40), but are accessible only by entering the Calibration menu passcode.



Note

The Input Image settings establish the “zero point” for the Picture menu settings, whose values represent offsets from the Input Image settings. For example, if you set Brightness to 10 in this menu, setting Brightness to 10 in the Picture menu results in an actual setting value of 20 (10+10).

Input Color: The Input Color controls are similar to those in the Display Color menu (see above), but adjust the color balance of the incoming signal. These settings are also saved independently for each input and display mode.

- **Gain/Offset (HD1, HD2 and Component/SCART inputs only):** These controls operate similarly to those in the **Display Color** menu (described on page 48), but affect the Y, Pb and Pr signal components rather than the red, green and blue channels.
- **Chroma Delay:** use the Chroma Delay control to correct a mis-aligned image from a Composite or S-Video source. Chroma delay in an image causes color shifts to occur to the left of the vertical edge transitions, producing artificial shadows or a “halo” effect. If necessary, adjust this setting to eliminate them.
- **Noise Filter:** To apply noise filtering to the input signal, select Noise Filter from the Input Color menu. The Noise Filter is useful for clearing up noisy images from 480i video sources.

Use the left- or right-arrow buttons to select the desired amount of noise reduction, keeping in mind that higher settings (which reduce high frequencies) may also “soften” the image.

Save ISF Night/Save ISF Day: Whenever you make a change to the ISF settings, you should always save it. Select Save ISF Night or Save ISF Day from the Calibration menu to do this.

Copy/Paste: You can copy and paste settings from one memory location to another. This gives you a convenient starting point for creating a new preset based on an existing one, to make the calibration process less time-consuming.

For example, you can use the Copy/Paste feature to:

- Apply settings from HDMI 1 to HDMI 2, or from HD1 to HD2.
- Calibrate an input for 720p source signals, then use those settings for 1080i sources.
- Duplicate ISF Night settings for a given source and signal format and save them in the Custom 1 memory preset.

To use this feature, select Copy/Paste from the Calibration menu.

- **Copy Settings:** Select Copy Settings from the Copy/Paste menu to place the settings for the current input source, signal format (resolution and frame rate) and memory preset onto a “clipboard,” which is a temporary memory location. When you do, the message “Settings Copied” briefly appears on-screen. The Copy/Paste menu then re-appears, indicating the source of the copied settings.

Copy/Paste	
Copy Settings	
Paste Settings	
Copied From:	
Input Source	HDMI 1
Signal Format	1080p/60
Memory Preset	ISF Night



Copied settings are not retained after a power cycle.

- **Paste Settings:** To apply the settings on the clipboard to a different input source, signal format and/or memory preset, do **any or all** of the following:
 - Switch to another DHD Controller input (for example, from HD1 to HD2).
 - Change the output signal format at the source (for example, from 720p/60 to 1080i/60).
 - Switch to another Memory Preset (for example, from ISF Night to Custom 1).

Then, select Paste Settings from the Copy/Paste menu. **If you want to keep these new settings, you must save them!** (Refer to **Save ISF Night/Save ISF Day** on page 50 or **Memory Presets** on page 47.)

Output Shift: The controls in the Output Shift menu are similar to those in the Input Position menu, except that they change the characteristics of the output signal. These settings are saved independently **for each aspect ratio**.

Splash Configure: Use the Splash Configure menu to control the appearance and behavior of the “splash” screen that appears on the display upon power-up.

- **Owner Name/ISF Calibrated/ISF Other:** You can have the CX-70DHD display the owner’s name, your name, the phrase “ISF Calibrated” and/or any other string, up to 30 characters in length.

Use the up or down cursor button to select a character. Use the right and left cursor buttons to change the cursor position. Press **MENU** when you have finished entering text.

- **Splash Timer:** When you turn on the CX-70DHD, it projects a welcome screen with the Runco and ISF logos, along with the personalized information you enter as described above. Select Splash Timer from the Splash Configure menu to set the amount of time for which this screen appears. The range is from 5 to 60 seconds, in one-second increments. Press ◀ or ▶ to set the timer, then press **MENU**.
- **Splash Enable:** When you have finished customizing the splash screen, select Splash Enable from the Splash Configure menu. Then, select On and press **ENTER**.

OSD Position: To adjust the position of the OSD, select OSD Position from the Calibration menu and press **ENTER**.

Press ▲ or ▼ to select “Hor.” or “Ver.” Then, press ◀ or ▶ to change the position.

Service ➤ Use the Service menu to access advanced display configuration settings. **This menu should be used by ISF-certified technicians only.**

Service	
Test Video	
Input Names	
Remote Control	
Display Device	
Color Space	
Triggers	
Miscellaneous	
Sync Threshold	
HDMI EDID Extension	
Front Panel Brightness	
System Reset	



Note

You must enter a passcode to access the Service menu.

Test Video: Select Test Video from the Service Menu to access the internal test patterns on the CX-70DHD. Four patterns are available: Horizontal Ramp, Vertical Ramp, Color Bars 1 (solid bars) and Color Bars 2 (SMPTE “checkerboard” pattern).

Press **MENU** to exit test pattern mode.

Input Names	
	Restore
Composite	Composite
S - Video 1	S-Video 1
S - Video 2	S-Video 2
Component	Component
HD 1	HD 1
HD 2	HD 2
SCART	SCART
HDMI 1	HDMI 1
HDMI 2	HDMI 2

Input Names: You can give each DHD Controller input a descriptive name. For example, you may want to change the default input name to the type of source component connected to it: “VCR,” “DVD,” “Laptop” et cetera. Input names can be up to 12 characters long.

To edit an input name, select Input Names from the Service menu. Press ▲ or ▼ to select an input and press **ENTER**. Use the ▲ or ▼ buttons to change a character; press ◀ or ▶ to select a character to change. When you have finished editing the input name, press **ENTER** or **MENU**.

To restore the default input name, press ▼ repeatedly to highlight that input name in the “Restore” column. Then, press **ENTER**.

Remote Control: Select Remote Control from the Service menu to change the following settings related to remote control operation.

- **Remote Code:** Select Remote Code from the Remote Control menu to set the infrared (IR) code set to which the CX-70DHD will respond. By default, it is set to 17. You can change this setting if either:
 - Another device in the theater (a DVD player, for example) is responding to commands from the CX-70DHD remote control (Figure 2-5) in ways that are unpredictable or undesirable.
 - You have multiple DHD Controllers and want to control them independently, as opposed to broadcasting commands from a single remote to all of them. In this scenario, you can use multiple remotes programmed to use different IR codes. Or, you can use a single remote and change the IR code as needed to address a specific DHD Controller.



Tip

Use the DHD Controller front-panel keypad to change the IR code to which the controller will respond. Then, change the code sent by the remote to match as described below.

When you change a remote code on the CX-70DHD, you must re-program the CX-70DHD remote control to send that same code. To do this:

1. Press and hold the **LIGHT** button on the remote control for approximately three seconds, or until the LED on the remote lights solid red.
2. Enter a new two-digit code between 00 and 31 inclusive. Include a leading zero for single-digit codes; for example, enter 9 as "09."
3. The LED turns off to confirm the code change. If you enter an invalid code, the LED flashes for three or four seconds. Try again, entering a valid code.

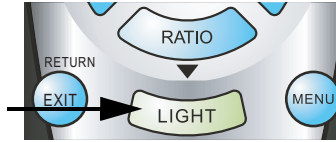

- **COMP Key Source:** Select COMP Key Source from the Remote Control menu to assign the COMP remote control button to either the Component or SCART input.

Display Device - Configure: The options in the Display Device - Configure menu allow you to change the picture orientation, perform lens adjustments or access other, display-device specific functions.

- **Installation – Orientation:** Select Installation from the Display Device - Configure menu, then select Orientation to change the picture orientation to suit the method of installation (Floor Front, Floor Rear, Ceiling Front or Ceiling Rear).
- **Diagnostics:** Select Diagnostics from the Display Device - Configure menu, then select Red, Green, Blue, Yellow, Cyan or Magenta to display only that color channel (simulating a filter of that color). This can be useful for calibration or measurement purposes.

To restore the normal picture (all colors), select White.

Color Space: Select Color Space from the Service menu to choose the color space of the source signal for HDMI, RGB, and component connections.

- The default setting, **Auto**, functions as follows:
 - **HDMI:** If the Auxiliary Video Information (AVI) infoframe contains color space and/or range data, the CX-70DHD uses that information. Otherwise, for RGB sources, the CX-70DHD uses the **RGB-Video** color space. For component SDTV and EDTV resolutions, **REC601** is used. For other component video resolutions, **REC709** is used.
 - **RGB:** If Hsync or Vsync signals are present, the CX-70DHD uses the **RGB-PC** color space. Otherwise, **REC601** is used for SDTV and EDTV sources, and **REC709** for all other sources.
 - **Component:** For SDTV and EDTV resolutions, the CX-70DHD uses the **REC601** color space. For all other resolutions, REC709 is used.

In most cases, the **Auto** setting determines the correct color space to use. If it does not, you can force the CX-70DHD to use a specific color space. Choose one of the following:

- **REC709** sets the color space matrix to that defined in ITU-R BT.709.
- **REC601** sets the color space matrix to that defined in ITU-R BT.601.
- **RGB-PC** uses RGB color space and sets black at 0,0,0 RGB and white at 255,255,255 RGB, assuming an 8-bit image.
- **RGB-Video** uses RGB color space and sets black at 16,16,16 RGB and white at 235,235,235, assuming an 8-bit image, to correspond to the luminance values defined in digital component standards.

Triggers: Select Triggers from the Service menu to configure the 12-volt trigger outputs. You can assign one or more trigger outputs to each aspect ratio. Those triggers are then activated by selecting that aspect ratio.

Miscellaneous: Select Miscellaneous from the Service menu to set the following options:

- **Language:** Select Language from the Miscellaneous menu and press the up- or down-arrows to select the OSD Language (English, Français, Deutsch, Italiano, Español, Svenska, Traditional Chinese, Simplified Chinese, Português or Russian).
- **OSD Timer:** Select OSD Timer from the Miscellaneous menu to set the OSD Timer, which controls how long the menus remain on-screen after selecting them. Select from 5 to 60 seconds, in one-second increments. Or, set the timer to 0 (disabled) if you want the menus to remain on-screen indefinitely.
- **OSD Messages:** When you select a new aspect ratio, input source or memory preset, the DHD Controller briefly displays an on-screen message confirming your new selection. To prevent the display of these messages, select OSD Messages from the Miscellaneous menu to and set it to Off.
- **Blank Screen Color:** Select Blank Screen Color from the Miscellaneous menu to select the color that appears when no incoming signal is present. The range is from 0 to 255 inclusive for each color component (red, green and blue).
- **Sidebar Color:** Select Sidebar Color from the Miscellaneous menu to change the color of the inactive image area. The range is from 0 to 255 inclusive for each color component (red, green and blue). The inactive image area is on either side of the active image area when using the 4:3 aspect ratio.
- **Film Mode:** Use Film Mode to smooth out moving images from interlaced, standard-definition (SD) sources. In most cases, the CX-70DHD detects the proper “pull-down” rate and vertical frequency. However, if your source is jittery and/or tearing you may want to enable Film Mode to ensure stable processing for that source.
- **CUE (Chroma Upsampling Error) Correction:** Some DVD players use MPEG decoders that do not correctly “upsample” the 4:2:0 format chroma information on the DVD to the 4:2:2 or 4:4:4 format required by the video encoder of the display device.

This so-called “chroma bug” sometimes causes streaky or spiky horizontal lines running through the chroma channel. It is most noticeable in static, interlaced scenes and on diagonal edges (especially red ones). Set CUE to On to correct this issue.

Sync Threshold: Select Sync Threshold to adjust the threshold at which negative pulses on the component video green/luma channel are interpreted to be sync pulses.

Sync Threshold adjustment is occasionally necessary when a DVD player or HDTV source signal drops “below black” (for example, during scenes with explosions or when subtitles are present) and causes the display device to temporarily lose sync. If the sync level from the source is persistently too low, the display device won’t sync with the source at all.

The range is from 0 (approximately 60 millivolts (mV)) to 15 (approximately 256 mV).

HDMI EDID Extension: Extended display identification data (EDID) is a data structure provided by a display device to describe its capabilities to a graphics card. It is what enables a modern personal computer to know what kind of monitor is connected.

Some modern display devices provide more information via EDID than others, in the form of “extensions.” Some computer graphics cards do recognize or properly interpret this extended EDID information.

Select HDMI EDID Extension from the Service menu to specify whether or not the EDID extensions from the display device are passed through to the sources connected to the HDMI 1 or HDMI 2 inputs. By default, the extensions are on. Change these settings only if HDMI EDID incompatibility issues arise.

Front Panel Brightness: Select Front Panel Brightness from the Service menu to adjust the brightness of the front-panel LED and LCD status indicators.

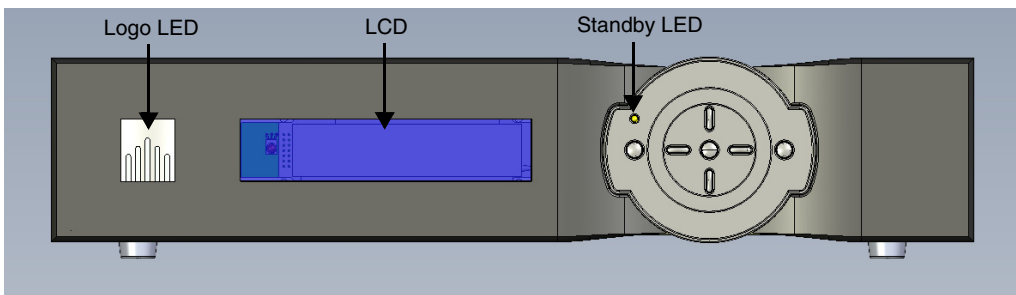

- **Logo LED:** Select Logo LED from the Front Panel Brightness menu to adjust the brightness of the large, illuminated logo on the left side of the display. The range is from 0 (off) to 31.
- **Standby LED:** Select Standby LED from the Front Panel Brightness menu to change the behavior of the front-panel STANDBY indicator LED. When set to ON, the LED lights amber when the system is in standby mode; otherwise, it is off. When set to OFF, the LED is always off.
- **LCD:** Select LCD from the Front Panel Brightness menu to adjust the brightness of the front-panel LCD. The range is from 0 (off) to 4.

System Reset: To reset ALL controller settings (including image settings) back to their factory defaults, choose System Reset from the Service menu.

A confirmation message appears. Select Yes to continue with the reset or select No to cancel.



Caution

This action is not undoable. Proceed with caution! Before you perform a System Reset, save your “Custom” Memory Presets (page 47) and ISF Day/Night Memory Presets (page 50).

Notes:

5. Maintenance and Troubleshooting

Regular cleaning will extend the life and performance of the CX-70DHD. Before cleaning, be sure to unplug the power cord from the power outlet.

Do not under any circumstances use solvents such as benzene or thinner to clean the CX-70DHD. Doing so may cause deterioration or peeling of paint from the display or remote control unit.

Wipe the display and remote control gently with a soft cloth. In the case of excessive dirt buildup, dampen a soft cloth with a diluted neutral cleaning detergent and after wringing the cloth thoroughly, wipe the component and then dry it with a dry soft cloth.

After dusting, wipe the screen gently using the supplied cleaning cloth or another soft cloth (cotton, flannel etc.). Do not use tissue or a rough cloth. The screen surface is easily scratched; do not rub it or hit it with a hard object.

If you clean the surface of the screen with a wet cloth, water droplets on the surface may enter into the product and cause a malfunction.

As a general rule, use a vacuum cleaner about once a month to clean the vents on the rear panel of the display of dust buildup (set the vacuum cleaner to its weakest setting when doing this). If not removed, accumulated dust can cause the internal temperature to increase, resulting in possible breakdown or fire.

Table 5-1 provides some general guidelines for troubleshooting problems you may encounter with the CX-70DHD. If the suggested solutions fail to resolve the problem or if you encounter an issue not described here, please contact your Runco dealer or Runco Technical Support.

Table 5-1. Troubleshooting Chart

Symptom	Possible Cause(s)	Solution
The display does not turn on after initial installation.	<ul style="list-style-type: none">The CX-70DHD is not plugged in or the AC outlet is not active.The DHD Controller is not plugged in or the AC outlet is not active.The remote control batteries have run out.The serial connection from the DHD Controller to the CX-70DHD is incorrect.	<ul style="list-style-type: none">Ensure that the CX-70DHD is plugged in and that the AC outlet is active.Ensure that the DHD Controller is plugged in and that the AC outlet is active.Replace the batteries.Ensure that the RS-232 (Display Control) output from the DHD Controller is properly connected to the RS-232C input on the CX-70DHD (see Figure 3-4 or Figure 3-5).

5.1 Cleaning

◀ Cleaning the Display Panel Body and Remote Control

◀ Cleaning the Screen

◀ Cleaning the Vents

5.2 Troubleshooting Tips

Table 5-1. Troubleshooting Chart (continued)

Symptom	Possible Cause(s)	Solution
The CX-70DHD and DHD Controller are both on, but there is no picture and on-screen menus do not appear.	<ul style="list-style-type: none"> Faulty or incorrect video connection between the DHD Controller and the CX-70DHD. 	<ul style="list-style-type: none"> Ensure that the HDMI output from the DHD Controller is properly connected to the DVI IN input on the CX-70DHD (see Figure 3-4).
The display is on and menus appear, but there is no picture.	<ul style="list-style-type: none"> Incorrect source selection. Source component is not turned on. Source component is connected incorrectly or not at all. 	<ul style="list-style-type: none"> Select the correct source. Turn on the source component. Check connections from source component to DHD Controller.
Image is too bright and/or lacks definition in the bright areas of the image.	<ul style="list-style-type: none"> Contrast is set too high. 	<ul style="list-style-type: none"> Lower the contrast setting.
Image appears “washed out” and/or dark areas appear too bright.	<ul style="list-style-type: none"> Brightness is set too high. 	<ul style="list-style-type: none"> Lower the brightness setting.
Colors in the image are swapped; for example, reds appear blue or vice versa.	<ul style="list-style-type: none"> The Red/Pr, Green/Y or Blue/Pb outputs from the source are connected to the wrong inputs on the DHD Controller. 	<ul style="list-style-type: none"> Ensure that the source outputs are connected to the correct DHD Controller input.
RGB-HD images appear “noisy.”	<ul style="list-style-type: none"> Tracking and Phase settings need adjustment. 	<ul style="list-style-type: none"> Adjust Tracking and Phase settings (refer to Input Position on page 45).
Computer images do not display correctly.	<ul style="list-style-type: none"> The resolution and frequency of the video card in the computer are not compatible with the CX-70DHD. 	<ul style="list-style-type: none"> Select a compatible resolution and vertical frequency (refer to Supported Timings on page 70).
The image is too large or too small.	<ul style="list-style-type: none"> Image size needs adjusting. 	<ul style="list-style-type: none"> Adjust the image size (refer to Input Position on page 45 or Output Shift on page 51).

6. External Control

In addition to using the DHD Controller front-panel keypad or remote control unit, there are two methods of controlling the CX-70DHD and DHD Controller externally:

- Using a serial (RS-232) link to send ASCII commands and receive responses to those commands.
- Using discrete infrared (IR) codes to program a third-party remote control unit.

The following sections describe both of these methods.

The DHD Controller uses a simple text-based control protocol to take requests from control devices and to provide responses to such devices. This section describes how to send control messages over a serial link between the DHD Controller and an automation/control system or a PC running terminal emulation software.

To interface the CX-70DHD with an automation/control system or a PC running terminal emulation software, connect it to the **Display Control** output of the DHD Controller as shown in Figure 3-4 and Figure 3-5. Connect your control system or PC to the RS-232 input of the DHD Controller as shown in Figure 3-11.

Configure the RS-232 controller or PC serial port as follows: no parity, eight (8) data bits, one (1) stop bit and no flow control. Set the baud rate to 19200, to match that of the DHD Controller RS-232 port.

Serial commands to the DHD Controller take the following form:

- Commands are not case-sensitive.
- For a single command that takes no parameters, type the command followed by a carriage return; for example, to set the aspect ratio to Letterbox, type `LETTERBOX <Enter>`.
- For a single command that takes a parameter, type the command, a space or a comma and the desired value followed by a carriage return; for example, to set the brightness to -10, type `BRIGHTNESS -10 <Enter>` or `BRIGHTNESS,-10 <Enter>`.
- You can also send a string of multiple commands on a single line, separated by commas. For example, `COMPOSITE,BRIGHTNESS 50,16:9<Enter>` switches to the Composite video input, sets the brightness to 50 and sets the aspect ratio to 16:9. Command strings can be up to 255 characters long.



Note

Avoid combining the `ON` or `POWER 1` commands with other commands on a single line. After sending `ON` or `POWER 1`, allow at least five (5) seconds for the DHD Controller to power up. If you have enabled the ISF splash screen (refer to **Splash Configure** on page 51), allow 15 seconds for the DHD Controller to power up.

Once it does, it will accept and properly execute multiple serial commands.

6.1 Serial Communications

◀ RS-232 Connection and Port Configuration

◀ Serial Command Syntax

Table 6-1 lists the RS-232 command set. The “Parameter (min/max)” column shows the valid parameter ranges, or “NA” for commands that take no parameters.

When you enter a valid command, the DHD Controller executes it and acknowledges it with a plus sign on the command line (+ >). When you enter an invalid command – one that is misspelled or followed by values outside the valid range for that command – the DHD Controller ignores it and returns a minus sign (- >).

Table 6-1. Serial Commands

Command	Parameter (min/max)	Value Stored?	Description
Power On/Off Commands			
OFF	NA	NA	Turns display off
ON	NA	NA	Turns display on
POWER	0/1	NA	Turns display on and off
POWER?	NA	NA	Returns power status
Input Selection Commands			
COMPONENT	NA	YES	Selects the Component input
COMPOSITE	NA	YES	Selects the Composite video input
HDMI1	NA	YES	Selects the HDMI 1 input
HDMI2	NA	YES	Selects the HDMI 2 input
HD1	NA	YES	Selects the RGB HD 1 input
HD2	NA	YES	Selects the RGB HD 2 input
INPUT?	NA	NA	Returns active input
SCART	NA	YES	Selects the SCART input
SVIDEO1	NA	YES	Selects the S-Video 1 input
SVIDEO2	NA	YES	Selects the S-Video 2 input

Table 6-1. Serial Commands (continued)

Command	Parameter (min/max)	Value Stored?	Description
Aspect Ratio Commands			
16:9	NA	YES	Selects the 16:9 aspect ratio
4:3	NA	YES	Selects the 4:3 aspect ratio
ASPECT?	NA	NA	Returns current aspect ratio
CINEMA	NA	YES	Selects the Cinema aspect ratio
LETTERBOX	NA	YES	Selects the Letterbox aspect ratio
NATIVE	NA	YES	Selects the Native aspect ratio
VIRTUALWIDE	NA	YES	Selects the VirtualWide aspect ratio
VIRTUALCINEMA	NA	YES	Selects the Virtual Cinema aspect ratio
Picture Adjust Commands			
BRIGHTNESS	-50/50	YES	Sets a value for brightness
BRIGHTNESS?	NA	NA	Returns brightness setting value
CHROMADELAY	-7/7	YES	Sets a value for input color chroma delay
CHROMADELAY?	NA	NA	Returns input color chroma delay setting
COLOR	-50/50	YES	Sets a value for color
COLOR?	NA	NA	Returns color setting value
CONTRAST	-50/50	YES	Sets a value for contrast
CONTRAST?	NA	NA	Returns contrast setting value
FILMMODE	0/1	YES	Sets Film Mode off (0) or on (1)
FILMMODE?	NA	NA	Returns Film Mode setting (0 = off; 1 = on)
FILTER	0/10	YES	Sets a value for input color noise filter
FILTER?	NA	NA	Returns input color noise filter setting
PHASE	0/31	YES	Adjusts phase
PHASE?	NA	NA	Returns phase setting value
SHARPNESS	-50/50	YES	Sets a value for sharpness
SHARPNESS?	NA	NA	Returns sharpness setting value
TINT	-50/50	YES	Sets a value for tint
TINT?	NA	NA	Returns tint setting value

Table 6-1. Serial Commands (continued)

Command	Parameter (min/max)	Value Stored?	Description
Image Preset Commands			
CUSTOM1	NA	YES	Loads "Custom 1" image preset
CUSTOM2	NA	YES	Loads "Custom 2" image preset
DAY	NA	YES	Loads "ISF Day" image preset
NIGHT	NA	YES	Loads "ISF Night" image preset
PRESET?	NA	NA	Returns currently-selected preset (ISF Day, ISF Night, Custom 1 or Custom 2)
Input Position Commands			
IHEIGHT	0/20	YES	Sets the value for input height
IHEIGHT?	NA	NA	Returns input height value
IHPOS	-50/50	YES	Sets a value for horizontal input position
IHPOS?	NA	NA	Returns input horizontal position value
IVPOS	-50/50	YES	Sets a value for vertical input position
IVPOS?	NA	NA	Returns input vertical position value
IWIDTH	0/50	YES	Sets the value for input width
IWIDTH?	NA	NA	Returns input horizontal width value
OVERSCAN	0/20	YES	Sets the overscan percentage
OVERSCAN?	NA	NA	Returns overscan percentage
OVERSCANMODE	0/1	YES	Sets the overscan mode (0=zoom; 1=crop)
OVERSCANMODE?	NA	NA	Returns the overscan mode (0=zoom; 1=crop)
Output Shift Commands			
OHEIGHT	-50/50	YES	Sets the value for output height
OHEIGHT?	NA	NA	Returns output height value
OHPOS	-50/50	YES	Sets the value for output horizontal position
OHPOS?	NA	NA	Returns output horizontal position value
OVPOS	-50/50	YES	Sets the value for output vertical position
OVPOS?	NA	NA	Returns output vertical position value
OWIDTH	-50/50	YES	Sets the value for output width
OWIDTH?	NA	NA	Returns output horizontal width value

Table 6-1. Serial Commands (continued)

Command	Parameter (min/max)	Value Stored?	Description
Miscellaneous Commands			
DISPLAY?	NA	NA	Returns display device input source value, as follows: 1 = Auto 37 = CX-70DHD
INRES?	NA	NA	Returns input resolution
MODEL?	NA	NA	Returns product model name
OUTRES?	NA	NA	Returns output resolution
SERNUM?	NA	NA	Returns DHD Controller serial number
SWVER?	NA	NA	Returns software version number
SYSSTATE?	0/4	NA	Returns current system state 0 = Off 1 = Initializing 2 = On 3 = Powering Down 4 = Error
TRIGGER	1/3	YES	Assigns trigger to currently-selected aspect ratio
The following serial commands are meant to emulate buttons on the remote control or DHD Controller front panel. Each button has its own serial command, so effectively it is as if you were using the IR remote only you'll be doing so via serial commands. These commands provide active OSD responses just like the IR remote.			
DOWN	NA	NA	Down-Arrow (▼) key
ENTER	NA	NA	ENTER key
EXIT	NA	NA	EXIT (RETURN) key
LEFT	NA	NA	Left-Arrow (◀) key
MENU	NA	NA	MENU
RIGHT	NA	NA	Right-Arrow (▶) key
UP	NA	NA	Up-Arrow (▲) key

6.2 Using Discrete IR Codes

The DHD Controller accepts commands in the form of IR signals that conform to the Phillips RC5 protocol. Each DHD Controller remote control button has an RC5 control code associated with it.

You can use these codes to program a third-party, “universal” remote control unit to work with the DHD Controller. These third-party products usually come with a computer software application for this purpose. For more information, consult the documentation provided with the remote control unit.

IR Command Protocol ➤

The IR control codes have the following characteristics:

- Each code consists of 14 bits:
 - Two (2) **start bits** (always 1);
 - A **toggle bit**. This bit is inverted every time a key is released and pressed again. This allows the DHD Controller to distinguish between a button that remains down or is pressed repeatedly.
 - Five (5) **address bits**. The default address is **17** (binary 10001). To change it, select Remote Control from the Service menu and follow the steps given on page 52.
 - Six (6) **data bits**.
- The carrier frequency is 36 kHz, with the modulated pulses having a 25% duty cycle.
- Commands are sent at a maximum rate of 9 Hz.

For example, here is the RC5 control code for the **ON** button on the DHD Controller remote control unit (assuming the default address is used):

With Toggle Bit = 0														
Hex	3		4				4				1			
Binary	1	1	0	1	0	0	0	1	0	0	0	0	0	1
With Toggle Bit = 1														
Hex	3		C				4				1			
Binary	1	1	1	1	0	0	0	1	0	0	0	0	0	1
Function	Start Bits	Toggle Bit	Address				Command							

Figure 6-1 shows the pulse train for this command (with the toggle bit set to zero).

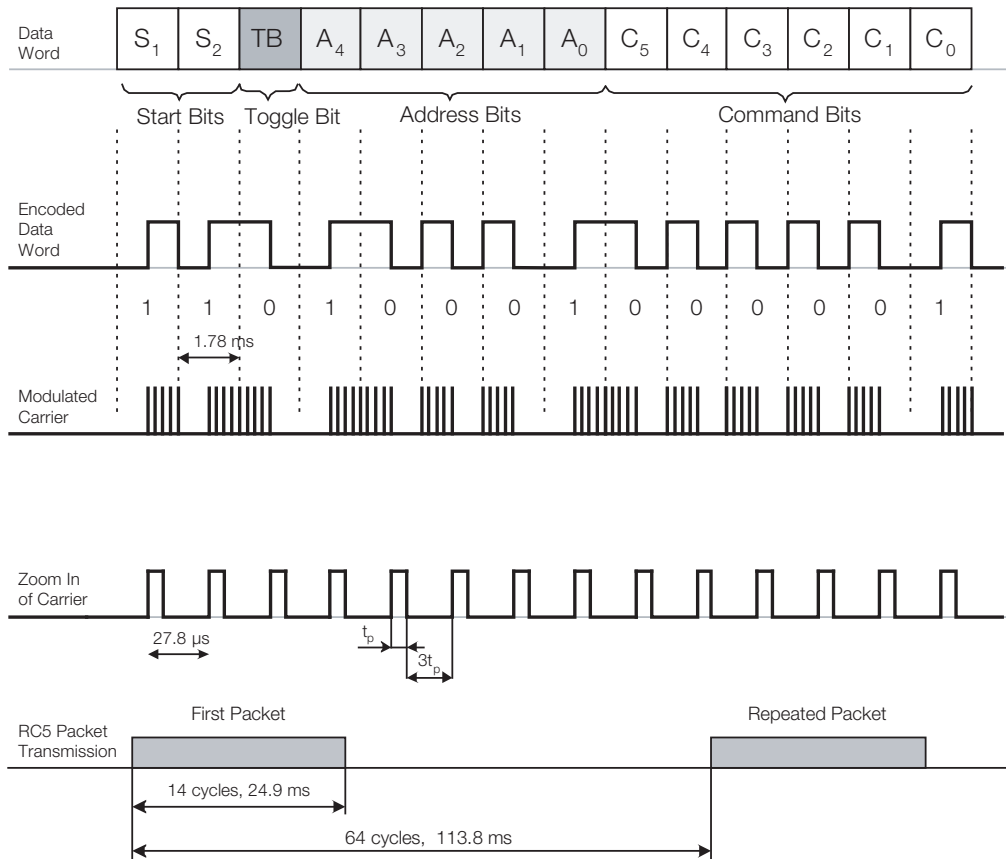

Figure 6-1. RC5 Message Format

Table 6-2 lists the RC5 control codes for the DHD Controller.

◀ **IR Command List**

Table 6-2. RC5 Control Codes for the DHD Controller

Remote Control Button Name	RC5 Data from Remote Control (Note)	RC5 Data with Toggle Bit = 1 (Note)	Description
(none)	0x346E	0x3C6E	Native aspect ratio
(none)	0x3457	0x3C57	SCART video input
16:9	0x3449	0x3C49	16:9 aspect ratio
4:3	0x344A	0x3C4A	4:3 aspect ratio
CINEMA	0x346C	0x3C6C	Cinema aspect ratio
COMP	0x344E	0x3C4E	Component video input

Note: These codes assume that the default address of 17 is used. If you change it to something other than 17, you will need to modify these codes accordingly.

Table 6-2. RC5 Control Codes for the DHD Controller (continued)

Remote Control Button Name	RC5 Data from Remote Control (Note)	RC5 Data with Toggle Bit = 1 (Note)	Description
CUST 1	0x3472	0x3C72	Custom 1 memory preset
CUST 2	0x3473	0x3C73	Custom 2 memory preset
DOWN	0x3446	0x3C46	Down-Arrow (▼)
ENTER	0x3444	0x3C44	ENTER
EXIT	0x3474	0x3C74	EXIT (RETURN)
HD 1	0x3451	0x3C51	HD1 video input
HD 2	0x3452	0x3C52	HD2 video input
HDMI 1	0x3453	0x3C53	HDMI1 video input
HDMI 2	0x3454	0x3C54	HDMI2 video input
ISF DAY	0x3471	0x3C71	ISF Day memory preset
ISF NIGHT	0x3470	0x3C70	ISF Night memory preset
LEFT	0x3447	0x3C47	Left-Arrow (◀)
LET BOX	0x344B	0x3C4B	Letterbox aspect ratio
MENU	0x3443	0x3C43	MENU
OFF	0x3442	0x3C42	Power off
ON	0x3441	0x3C41	Power on
RIGHT	0x3448	0x3C48	Right-Arrow (▶)
SVC	0x346D	0x3C6D	Virtual Cinema aspect ratio
S-VID 1	0x344F	0x3C4F	S-Video 1 video input
S-VID 2	0x3450	0x3C50	S-Video 2 video input
UP	0x3445	0x3C45	Up-Arrow (▲)
VIDEO	0x344D	0x3C4D	Composite video input
V-WIDE	0x344C	0x3C4C	VirtualWide aspect ratio

Note: These codes assume that the default address of 17 is used. If you change it to something other than 17, you will need to modify these codes accordingly.

7. Specifications

Table 7-1 lists the CX-70DHD specifications.

Table 7-1. CX-70DHD Specifications

Native Resolution:	1920 x 1080
Screen Size (Active Area):	61.00 in. W x 34.31 in. H (1549.4 x 871.6 mm) 70 in. (1778.0 mm) diagonal
Screen Aspect Ratio:	16:9
Available Aspect Ratios:	Refer to Table 7-2
DTV Compatibility:	480p, 720p, 1080i, 1080p
Response Time:	13 milliseconds, maximum
Contrast Ratio:	1,500:1, nominal
Data/Graphics Compatibility (DVI-D input):	VGA, SVGA, XGA, SXGA, UXGA (compressed) Horiz. scan frequency = 31.5 to 91.1 kHz Vert. scan frequency = 50 to 120 Hz Pixel clock frequency = 25 to 165 MHz
Inputs (from DHD Controller):	(1) Digital Video (DVI-D) with HDCP (1) RS-232 (8-pin, RJ-45 female)
Power Requirements:	100 to 240 VAC, 50/60Hz (auto-switching)
Current:	6.5 Amps at 115 VAC; 3.25 Amps at 230 VAC
Power Consumption:	750 watts (2559.7 BTUs/hour), maximum
Operating Environment:	32°F to 95°F (0°C to 35°C); 20% to 80% humidity (non-condensing)
Dimensions:	See Figure 7-1
Weight (panel only, without stand):	158.0 lbs. (71.7 kg)
Regulatory Approvals:	FCC 47 CFR Part 15 Class A EN55022/CISPR 22 EN55024 EN60950 UL60950 ICES-003
Limited Warranty:	Two (2) years parts and labor from the date of delivery to the end user.

7.1 CX-70DHD Specifications

Specifications are subject to change without notice.

7.2 DHD Controller Specifications

Table 7-2 lists the DHD Controller specifications.

Table 7-2. DHD Controller Specifications

Aspect Ratios:	4:3, Letterbox, 16:9, VirtualWide, Cinema, Virtual Cinema, Native
Video Standards:	NTSC, PAL, SECAM
Inputs:	(1) Composite (2) S-Video (1) Component/RGBHV/SCART (5 x RCA) (2) Component/RGBHV (5 x BNC) (2) HDMI 1.3 with HDCP
Outputs:	HDMI 1.3 with HDCP
Control Options:	<ul style="list-style-type: none"> - Discrete infrared remote - Serial commands via RS-232 - Front-panel controls
RS-232 Communication Parameters:	19200 bps, no parity, 8 data bits, 1 stop bit, no flow control
Trigger Outputs:	(3) +12 VDC, each rated at 250 mA and thermal fuse-protected
Bandwidth:	150 Mega Samples per Second (MSPS)
Power Requirements:	100 to 240 VAC (auto-sensing), 50/60 Hz, 160 Watts
Operating Environment:	41°F to 95°F (5°C to 35°C), 0% to 90% humidity (non-condensing)
Dimensions:	Width = 17.50 inches (444.5 mm) Depth = 11.19 inches (284.1 mm) Height = 3.75 inches (95.3 mm)
Weight:	13.0 lbs. (5.90 kg)
Regulatory Approvals:	Complies with FCC, CE C-Tick
Limited Warranty:	Two (2) years parts and labor from the date of delivery to the end user.
Specifications are subject to change without notice.	

Figure 7-1 shows the CX-70DHD dimensions (all dimensions are in inches).

7.3 CX-70DHD Dimensions

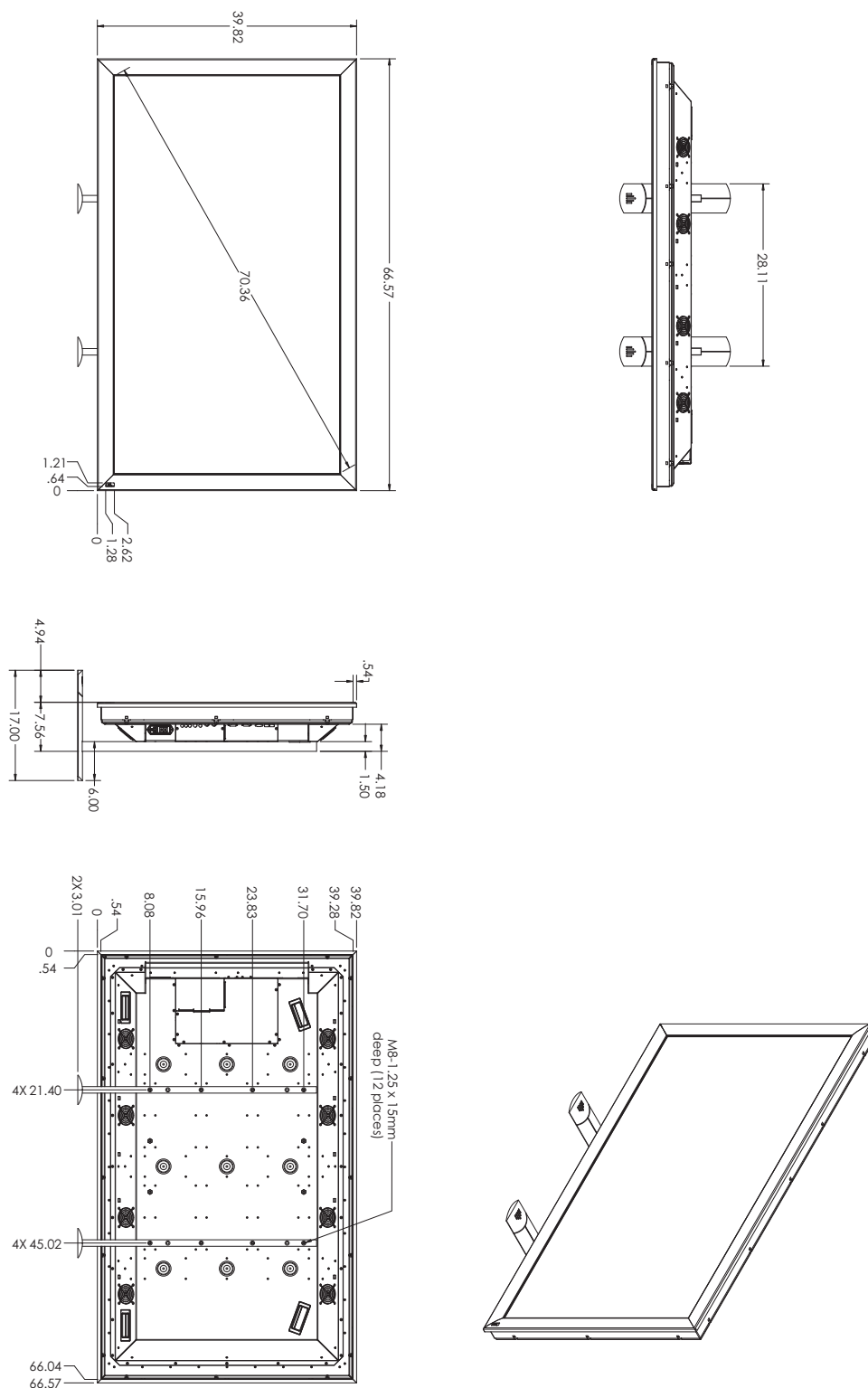

Figure 7-1. CX-70DHD Dimensions (with Table Stand)

7.4 Supported Timings

Table 7-3 lists the signal types supported by each input on the DHD Controller.

Table 7-3. Supported Signal Timings by Input

Format	Resolution	Refresh Rate (Hz)	Horizontal Frequency (kHz)	Pixel Frequency (MHz)	Supported? (√ = Yes, - = No)					
					HD1 HD2	HDMI 1 HDMI 2	Component/ RGBHV	SCART	S-Video 1 S-Video 2	Video
640x480	640x480	60.00	31.469	25.175	√	√	√	-	-	-
		66.59	35.892	29.862	√	√	√	-	-	-
		72.00	37.861	31.500	√	√	√	-	-	-
		75.00	37.500	31.500	√	√	√	-	-	-
		85.00	43.269	36.000	√	√	√	-	-	-
800x600	800x600	60.00	37.879	40.000	√	√	√	-	-	-
		72.00	48.077	50.000	√	√	√	-	-	-
		75.00	46.875	49.500	√	√	√	-	-	-
		85.00	53.674	56.250	√	√	√	-	-	-
832x624	832x624	74.54	52.849	60.036	√	√	√	-	-	-
848x480	848x480	47.95	25.270	27.089	√	√	√	-	-	-
		60.00	31.020	33.750	√	√	√	-	-	-
1024x768	1024x768	60.00	48.363	65.000	√	√	√	-	-	-
		70.00	56.476	75.000	√	√	√	-	-	-
		75.00	60.023	78.750	√	√	√	-	-	-
		85.00	68.677	94.500	√	√	√	-	-	-
1152x864	1152x864	75.00	67.500	108.000	√	√	√	-	-	-
1280x720	1280x720	47.95	37.833	64.769	√	√	√	-	-	-
1280x768	1280x768	60.00	47.396	68.250	√	√	√	-	-	-
		60.00	47.776	79.500	√	√	√	-	-	-
		75.00	60.289	102.250	√	√	√	-	-	-
		85.00	68.633	117.500	√	√	√	-	-	-
1280x960	1280x960	60.00	60.000	108.000	√	√	√	-	-	-
		85.00	85.938	148.500	√	√	√	-	-	-

Table 7-3. Supported Signal Timings by Input (continued)

Format	Resolution	Refresh Rate (Hz)	Horizontal Frequency (kHz)	Pixel Frequency (MHz)	Supported? (√ = Yes, – = No)					
					HD1 HD2	HDMI 1 HDMI 2	Component/ RGBHV	SCART	S-Video 1 S-Video 2	Video
1280x1024	1280x1024	60.00	63.981	108.000	√	√	√	–	–	–
		75.00	79.976	135.000	√	√	√	–	–	–
		85.00	91.146	157.500	√	√	√	–	–	–
1360x768	1360x768	60.00	47.712	85.500	√	√	√	–	–	–
1400x1050	1400x1050	60.00	64.744	101.000	√	√	√	–	–	–
		60.00	65.317	121.750	√	√	√	–	–	–
		75.00	82.278	156.000	√	√	√	–	–	–
1600x1200	1600x1200	60.00	75.000	162.000	√	√	√	–	–	–
1680x1050	1680x1050	60.00	64.674	119.000	√	√	√	–	–	–
1920x1080	1920x1080	47.95	56.821	150.007	√	√	√	–	–	–
1920x1200	1920x1200	60.00	74.038	154.000	√	√	√	–	–	–
SCART RGSB	–	50.00	–	–	–	–	–	√	–	–
480/60i	720x487	59.94	15.734	13.500	√	√	√	–	–	–
480/60p	720x483	59.94	31.469	27.000	√	√	√	–	–	–
576/50i	720x576	50.00	15.625	14.750	√	√	√	–	–	–
576/50p	720x576	50.00	31.250	29.000	√	√	√	–	–	–
720/24p	1280x720	23.98/24.00	17.982/18.000	59.341/59.400	√	√	√	–	–	–
720/25p	1280x720	25.00	18.750	74.250	√	√	√	–	–	–
720/30p	1280x720	29.97/30.00	22.478/22.500	74.175/74.250	√	√	√	–	–	–
720/50p	1280x720	50.00	37.500	75.250	√	√	√	–	–	–
720/60p	1280x720	60.00	45.000	74.250	√	√	√	–	–	–
1080/50i	1920x1080	50.00	28.125/31.250	74.250/72.000	√	√	√	–	–	–
1080/60i	1920x1080	59.94/60.00	33.716/33.750	74.175/74.250	√	√	√	–	–	–
1080/24p	1920x1080	23.98/24.00	26.978/27.000	74.175/74.250	√	√	√	–	–	–
1080/50p	1920x1080	50.00	56.250	148.500	√	√	√	–	–	–
1080/60p	1920x1080	59.94/60.00	67.433/67.500	148.350/148.500	√	√	√	–	–	–
NTSC 3.58	–	59.94/60.00	15.734/15.750	3.580	–	–	–	–	√	√
NTSC 4.43	–	59.94/60.00	15.734/15.750	4.430	–	–	–	–	√	√
PAL-B/G/H/I	–	50.00	15.625	4.430	–	–	–	–	√	√

Table 7-3. Supported Signal Timings by Input (continued)

Format	Resolution	Refresh Rate (Hz)	Horizontal Frequency (kHz)	Pixel Frequency (MHz)	Supported? (√ = Yes, - = No)					
					HD1 HD2	HDMI 1 HDMI 2	Component/ RGBHV	SCART	S-Video 1 S-Video 2	Video
PAL-M	-	59.94/60.00	15.734/15.750	3.580	-	-	-	-	√	√
PAL-N	-	50.00	15.625	3.580	-	-	-	-	√	√
SECAM	-	50.00	15.625	13.500	-	-	-	√	√	√

020-0925-01 Rev. B
April 2009

Runco International • (800) 23RUNCO • Fax (503) 748-8161 • www.runco.com

Free Manuals Download Website

<http://myh66.com>

<http://usermanuals.us>

<http://www.somanuals.com>

<http://www.4manuals.cc>

<http://www.manual-lib.com>

<http://www.404manual.com>

<http://www.luxmanual.com>

<http://aubethermostatmanual.com>

Golf course search by state

<http://golfingnear.com>

Email search by domain

<http://emailbydomain.com>

Auto manuals search

<http://auto.somanuals.com>

TV manuals search

<http://tv.somanuals.com>