



INSTALLATION/OPERATION MANUAL

*LightStyle*TM

LS-100d

**Ultra Short Throw, Full-HD LED Home Theater Projector
and Digital High Definition (DHDTM) Controller/Scaler/Processor**

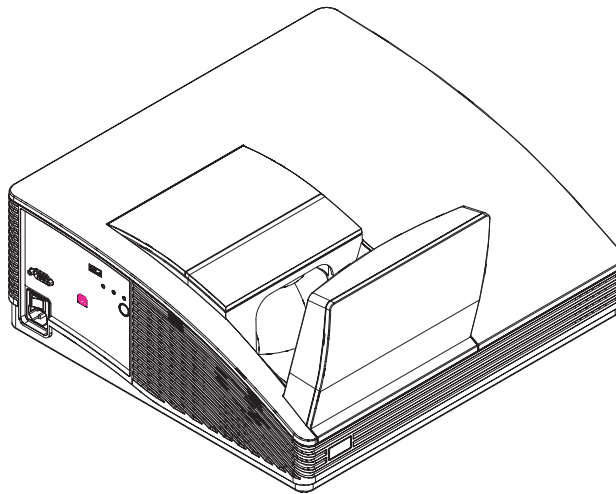

THE WORLD'S FINEST HOME THEATER PRODUCTSTM

RuncoCare™ Standard Two Year Limited Warranty

Congratulations on your purchase of a Runco® product! With proper installation, setup and care, you should enjoy many years of unparalleled video performance.

This Limited Warranty is provided free of charge by Runco International, LLC ("Runco") with the purchase of a covered Runco product. This Limited Warranty is applicable to all Runco projectors, processors, LCD display and plasma display products, with the exception of the following models: XP-103DHD, SC-1 and SC-1a¹. This Limited Warranty applies to purchases of covered Runco products occurring on or after **June 1, 2011**.

RuncoCare™ Limited Warranty Coverage

Runco warrants its products to be free from defects in material and workmanship during the warranty period provided below. If a product proves to be defective in material or workmanship during the warranty period, Runco will repair the product, replace the product with a substantially similar new or like-new product, or refund a prorated share of the purchase price (calculated based on the remainder of the warranty period and the then-current, most-recent MSRP² of a similar product), if repair or replacement of the product is determined by Runco to not be feasible.

Length of RuncoCare™ Warranty Period

Runco products are warranted for two (2) years from the date of shipment from Runco. Lamps are warranted six (6) months from the date of shipment or 1000 hours of use, whichever comes first. A replacement lamp is warranted for the remaining portion (if any) of the original warranty period or ninety (90) days from the date it was shipped to you, whichever is longer. All other accessories, which include but are not limited to cables, remotes, carrying cases, lens cap and other peripherals sold with the Runco product, are warranted for ninety (90) days from the date of shipment.

RuncoCare™ Eligibility

This Limited Warranty is valid only in the country where the Product was originally purchased and for the buyer who originally purchased the covered product from the authorized Runco dealer or distributor. This warranty is not transferable; it is not valid for any subsequent buyer (if any). You may be required to provide proof of purchase in order to receive warranty services.

-
1. Runco may update this list of products excluded from this warranty from time to time at Runco's sole discretion, but updates will not apply on a retroactive basis.
 2. MSRP is defined as the most recent product price listed on Runco's price list.

RuncoCare™ Standard Claim Procedure

- In the event of a product defect, please follow the claim procedure provided below:
 - A. Register your product if you have not yet done so. Visit <http://www.runco.com/support/product-registration/> to register the product.
 - B. Contact your original authorized dealer or distributor who sold the product.
 - C. The dealer/distributor will contact Runco Technical Support via email at support@runco.com or via phone at 1-800-23-RUNCO (1-800-237-8626).
- The dealer/distributor will provide to Runco proof of purchase, serial number, product model number, description of the problem and any troubleshooting steps already attempted.
- Runco's technical support staff will attempt to assist the dealer/distributor in troubleshooting any technical issues that might be causing the product to malfunction. If Runco is unable to resolve the problem through troubleshooting, a Return Material Authorization (RMA) number will be issued for the exchange of the defective product if it is determined that the claim is covered by the warranty. Once an RMA has been created, RMA status is available at serviceorders@runco.com.
- If an RMA is issued, the dealer or customer will need to return the defective product to the Runco repair depot location specified by the Runco technical support representative. The dealer or customer will need to properly package the defective product in a suitable shipping container consisting of the product only, and not include any accessories (e.g., cables, remotes, carrying cases, lens, lens cap and other peripherals). Boxes may be purchased from a Runco technical support representative.
- The dealer or customer is responsible for paying freight charges and insurance to ship the defective product to the Runco repair depot location. If there are any shipping damages, the dealer or customer will need to address and resolve any shipping damage claims directly with the shipping company.
- Runco will not accept a returned product unless an RMA has been issued by Runco.
- For in-warranty repairs, Runco will pay freight charges to return the repaired/replacement product to the dealer/distributor from the Runco repair depot. For select countries or geographies Runco will ship via an economy express service. Return delivery time and availability may vary based on origin and destination, and Runco is unable to deliver to PO Box and FPO Box addresses.
- Note: in the 48 contiguous United States, other options for on-site service or advance exchange for the product may apply, if you purchased the Runco PremierCare™ Service Plan.

What to Include with Your Return

1. Return only the defective product with the lamp (if applicable).
2. Runco will not be responsible for returning or replacing any accessories (e.g., cables, remotes, carrying cases, lens, lens cap and other peripherals sold with the Runco product) that are returned with the defective product.
3. Repaired or replacement products will be shipped with a lamp (if applicable) but without any accessories.

RuncoCare™ Warranty Exclusions

This Limited Warranty does not include and is limited by the following:

1. Products not purchased from an authorized Runco dealer
2. Rental costs incurred by the customer in the event of product defect or failure
3. Any product with a defaced, modified, or removed serial number

-
4. Damage, deterioration, or malfunction resulting from:
 - A. Accident, abuse, misuse, neglect, improper ventilation, fire, water, disaster, lightning, or other acts of nature, smoke exposure (cigarette or otherwise), unauthorized product modification (including use of an unauthorized mount), or failure to follow instructions supplied with the product
 - B. Repair or attempted repair by anyone not authorized by Runco
 - C. Any damage to the product due to shipment
 - D. Removal or installation of the product
 - E. Causes external to the product, such as electric power fluctuations or failure
 - F. Use of supplies or parts (including lamps) that are not purchased from Runco or do not meet Runco's specifications
 - G. Normal wear and tear
 - H. Expected lamp degradation and normal decrease in lamp output over a period of time or as the lamp is consumed
 - I. Customer caused defects, including but not limited to, scratched/defaced/altered plastics
 - J. Failure to follow maintenance procedures as outlined in the product's user guide where a schedule is specified for regular cleaning of the product
 - K. Opening the product and/or tampering with internal circuitry
 - L. Products lost, stolen or discarded
 - M. Any damage or dissatisfaction associated with latent images, "burnin," or any other damage determined by Runco to be the result of customer use patterns
 - N. Any other cause, which does not relate to a product defect in material or workmanship
 5. Removal, installation, and set-up service charges are excluded from the warranty.
 6. Black uniformity issues or other LCD issues associated with usage outside the Runco recommended guidelines and specifications for the product.
 7. Bright or dark sub pixels that are characteristic of LCD technology and considered by Runco to be acceptable and within Runco's manufacturing specifications.

Specifically, it is not uncommon for one or more sub pixels to become bright or dark during or after the manufacturing process. A bright sub pixel is one that remains in the on position, and a dark sub pixel is one that appears black or off. The sub pixels are usually hard to see and will not detract from the display quality or usability at normal viewing distance. The following are Runco's criteria for identifying bright or dark sub pixels that would be considered unacceptable: a) the number of bright or dark sub pixels; b) the location of the bright or dark sub pixels; c) the color of the bright sub pixels; and d) the Runco model size. If sub pixels have been identified as unacceptable by Runco the LCD will be deemed faulty and will be replaced if reported within the warranty period.

Other Terms and Conditions

1. If the defective product is not properly packaged and is damaged in transit during its return to Runco, you may be invoiced for either the repair costs, if repairable, or the MSRP of a replacement product and shipping costs incurred by Runco.
2. The repaired or replaced product will assume the remainder of your original product's warranty term or 90 days from the date the repaired or replaced product is shipped, whichever is longer.
3. If a replacement product is sent, the replacement becomes the property of the customer and the defective product becomes the property of Runco.

RuncoCare™ Extended Service Options

Runco offers extended and expanded service plans. For information on additional product protection, please ask your authorized Runco dealer, email serviceorders@runco.com or call (toll free) (800) 23-RUNCO (800-237-8626).

Exclusion of Implied Warranties

RUNCO PROVIDES NO WARRANTIES, EXPRESS OR IMPLIED, EXCEPT THOSE EXPRESSLY PROVIDED IN THIS DOCUMENT. RUNCO EXPRESSLY DISCLAIMS AND EXCLUDES ALL OTHER WARRANTIES, INCLUDING THE IMPLIED WARRANTIES OF TITLE, NONINFRINGEMENT, MERCHANTABILITY AND FITNESS FOR A PARTICULAR PURPOSE.

Limitation of Liability; Exclusion of Damages

RUNCO'S MAXIMUM AGGREGATE LIABILITY IS LIMITED TO THE COST OF REPAIR, REPLACEMENT OR REFUND OF THE PRODUCT.

RUNCO WILL NOT BE LIABLE FOR DAMAGE TO OTHER PROPERTY OR FOR DAMAGES BASED UPON INCONVENIENCE, LOSS OF USE OF THE PRODUCT, LOSS OF TIME, LOSS OF PROFITS, LOSS OF BUSINESS OPPORTUNITY, LOSS OF GOODWILL, INTERFERENCE WITH BUSINESS RELATIONSHIPS, OR OTHER COMMERCIAL OR FINANCIAL LOSS, EVEN IF RUNCO IS AWARE OF THE POSSIBILITY OF SUCH DAMAGES AND EVEN IF A REMEDY HAS FAILED OF ITS ESSENTIAL PURPOSE.

RUNCO WILL NOT BE LIABLE FOR ANY CONSEQUENTIAL, INCIDENTAL, INDIRECT, EXEMPLARY, SPECIAL, PUNITIVE OR ANY OTHER TYPE OF DAMAGES, WHETHER THE CLAIM IS BASED ON CONTRACT, TORT, PRODUCT LIABILITY, NEGLIGENCE, STRICT LIABILITY OR ANY OTHER LEGAL OR EQUITABLE THEORY.

RUNCO WILL NOT BE LIABLE FOR ANY CLAIM AGAINST THE CUSTOMER BY ANY OTHER PARTY.

Effect of Local Law

This Limited Warranty gives you specific legal rights, and you may have other rights, which vary from locality to locality. Some localities do not allow limitations on implied warranties and/or do not allow the exclusion of incidental or consequential damages, so the above limitations and exclusions may not apply to you.

COPYRIGHT AND TRADEMARKS:

© Copyright 2011 Runco International, LLC ("Runco"). This document contains proprietary information protected by copyright, trademark and other intellectual property laws. All rights are reserved. No part of this manual may be reproduced by any mechanical, electronic or other means, in any form, without prior written permission of Runco.

The trademarks reproduced in this Runco Owner's Manual and used on the Runco Products are either owned by Runco or are licensed by Runco. You may not reproduce or use the trademarks without the prior written consent of Runco.

Runco Products are manufactured under one or more of the following patents: US. Patent 6755540 and Other Patents Pending.

Important Safety Instructions

Thank you for your purchase of this quality Runco video product! It has been designed to provide you with the quality of video that is expected in a home theater. For the best performance, please read this manual carefully as it is your guide through the menus and operation.

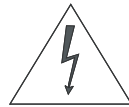
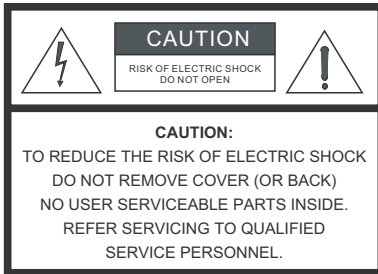

WARNING

This symbol is intended to alert the user to the presence of uninsulated “dangerous voltage” within the product’s enclosure that may be of sufficient magnitude to constitute a risk of electric shock.



This symbol is intended to alert the user to the presence of important operating and maintenance (servicing) instructions in the literature accompanying the appliance.

1. Read these instructions.
2. Keep these instructions.
3. Heed all warnings.
4. Follow all instructions.
5. Do not use this apparatus near water.
6. Clean only with a dry cloth.
7. Do not block any of the ventilation openings. Install in accordance with the manufacturer’s instructions.
8. Do not install near any heat sources such as radiators, heat registers, stoves, or other apparatus (including amplifiers) that produce heat.
9. Do not defeat the safety purpose of the polarized or grounding type plug. A polarized plug has two blades with one wider than the other. A grounding type plug has two blades and a third grounding prong. The wide blade or the third prong is provided for your safety. When the provided plug does not fit into your outlet, consult an electrician for the replacement of the obsolete outlet.
10. Protect the power cord from being walked on or pinched particularly at plugs, convenience receptacles and the point where they exit from the apparatus.
11. Only use the attachments/accessories specified by the manufacturer.
12. Use only with a cart, stand, tripod, bracket or table specified by the manufacturer or sold with the apparatus. When a cart is used, use caution when moving the cart/apparatus to avoid injury from tip-over.
13. Unplug this apparatus during lightning storms or when unused for long periods of time.
14. Refer all servicing to qualified service personnel. Servicing is required when the apparatus has been damaged in any way, such as power supply cord or plug is damaged, liquid has been spilled or objects have fallen into the apparatus, the apparatus has been exposed to rain or moisture, does not operate normally, or has been dropped.
15. The +12V trigger only outputs 12Vdc signal for triggering. Do not connect to any other power input or output. This could cause damage to this unit.
16. Keep the packing material in case the equipment should ever need to be shipped.
17. Never look directly into the lens when the projector is on.



Compliance Information

DECLARATION OF CONFORMITY:

Manufacturer's Name: Runco International, LLC

Manufacturer's Address: 1195 NW Compton Drive, Beaverton, OR 97006-1992

hereby declares that the Products' Model Numbers:

LS-100d

conform with the provisions of:

Council Directive 2004/108/EC on Electromagnetic Compatibility;

EN 55022 "Limits and methods of measurements of radio interference characteristics of information technology equipment" 1998;

EN 55024 "Limits and methods of measurements of immunity characteristics of information technology equipment" 1998;

Including:

- EN 61000-4-2 "Electromagnetic compatibility (EMC) Part 4: Testing and measurement techniques Section 2: Electrostatic discharge immunity test"
- EN 61000-4-3 "Electromagnetic compatibility (EMC) Part 4: Testing and measurement techniques Section 3: Radiated, Radio-Frequency, Electromagnetic Field Immunity Test"
- EN 61000-4-4 "Electromagnetic compatibility (EMC) Part 4: Testing and measurement techniques Section 4: Electrical fast transient/burst immunity test"
- EN 61000-4-5 "Electromagnetic compatibility (EMC) Part 4: Testing and measurement techniques Section 5: Surge immunity test"
- EN 61000-4-6 "Electromagnetic compatibility (EMC) Part 4: Testing and measurement techniques Section 6: Conducted disturbances induced by radio-frequency fields immunity test"
- EN 61000-4-8 "Electromagnetic compatibility (EMC) Part 4: Testing and measurement techniques Section 8: Conducted disturbances induced by power frequency magnetic fields immunity test"
- EN 61000-4-11 "Electromagnetic compatibility (EMC) Part 4: Testing and measurement techniques Section 11: Voltage dips, short interruptions and voltage variations immunity tests"

And:

- EN 61000-3-2 "Electromagnetic compatibility (EMC) Part 3, Section 2: Limits for harmonic current emissions (equipment input current up to and including 16 A per phase)" 2000;
- EN 61000-3-3 "Electromagnetic compatibility (EMC) Part 3, Section 3: Limitations of voltage changes, voltage fluctuations and flicker in public low-voltage supply systems, for equipment with rated current up to and including 16 A and not subject to conditional connection" 1995;

Council Directive 2006/95/EC and amended by M1 and C1 on Low Voltage Equipment Safety;

EN 60950 "Safety of information technology equipment, including electrical business equipment"

The Technical Construction file required by this Directive is maintained at the corporate headquarters of Runco International, LLC, located at 1195 NW Compton Drive, Beaverton, OR 97006-1992.

Date of Declaration: December 2011

FCC PART 15:

NOTE: This equipment has been tested and found to comply with the limits for a Class B digital device, pursuant to Part 15 of the FCC Rules. These limits are designed to provide reasonable protection against harmful interference in a residential installation.

This equipment generates, uses and can radiate radio frequency energy and, if not installed and used in accordance with the instructions, may cause harmful interference to radio communications. However, there is no guarantee that interference will not occur in a particular installation. If this equipment does cause harmful interference to radio or television reception, which can be determined by turning the equipment off and on, the user is encouraged to try to correct the interference by one or more of the following measures:

- Reorient or relocate the receiving antenna.
- Increase the separation between the equipment and receiver.
- Connect the equipment into an outlet on a circuit different from that to which the receiver is connected.
- Consult the dealer or an experienced radio/TV technician for help.

INDUSTRY CANADA (ICES-003):

This Class B digital apparatus complies with Canadian ICES-003.

Cet appareil numérique de la classe B est conforme à la norme NMB-003 du Canada.

PRODUCT DISPOSAL:

The Product contains small amounts of tin, lead and/or mercury. Disposal of these materials may be regulated due to environmental considerations.

IMPORTANT RECYCLE INSTRUCTIONS



Lamp(s) inside this product contain mercury. This product may contain other electronic waste that can be hazardous if not disposed of properly. Recycle or dispose in accordance with local, state, or federal Laws.

For more information, contact the Electronic Industries Alliance at WWW.EIAE.ORG.

For lamp specific disposal information check WWW.LAMPRECYCLE.ORG.

DISPOSAL OF OLD ELECTRICAL AND ELECTRONIC EQUIPMENT (Applicable throughout the European Union and other European countries with separate collection programs)



This symbol found on your product or on its packaging, indicates that this product should not be treated as household waste when you wish to dispose of it. Instead, it should be handed over to an applicable collection point for the recycling of electrical and electronic equipment. By ensuring this product is disposed of correctly, you will help prevent potential negative consequences to the environment and human health, which could otherwise be caused by inappropriate disposal of this product. The recycling of materials will help to conserve natural resources. This symbol is only valid in the European Union. If you wish to discard this product, please contact your local authorities or dealer and ask for the correct method of disposal.

Notes:

Table of Contents

RuncoCare™ Standard Two Year Limited Warranty	iii
Important Safety Instructions	vii
Compliance Information	viii
1. Introduction	1
About This Manual	1
Target Audience	1
If You Have Comments About This Manual.....	1
Textual and Graphic Conventions	1
Using This Manual	2
Description, Features and Benefits	3
Key Features and Benefits	3
Parts List	3
2. Controls and Functions	5
LS-100d at a Glance	5
LS-100d Input Panel	6
DHD Controller Front Panel	7
DHD Controller Rear Panel	8
LS-100d Remote Control Unit	10
3. Installation	13
Remote Control	13
Notes on Batteries	13
Notes on Remote Control Operation.....	13
Quick Setup	14
Installation Considerations	15
Screen Requirements	15
Ambient Light	15
Rear Projection	16
Projection Distance and Image Size	16
Audio/Video Synchronization Issues.....	17
Other Considerations	17

Mounting the LS-100d	18
Floor Mounting (Upright)	18
Wall or Ceiling Mounting	18
Adjusting the Projection Angle	18
Connections to the LS-100d and DHD Controller	19
Connecting the DHD Controller to the LS-100d	19
Connecting Source Components to the DHD Controller	21
Connecting an Audio Processor or Secondary Display Device to the DHD Controller (Optional).....	26
Additional Connections to the DHD Controller (Optional).....	27
Connecting to AC Power	29
Turning on the Power	30
Lens Focus Adjustment	31
Adjusting the Picture Orientation	31
Adjusting the Image Geometry	32
4. Operation	35
Using the On-Screen Menus	35
Main Menu.....	37
Input Source.....	37
Aspect Ratio	37
Screen.....	40
Picture.....	40
Input Position.....	44
Memory Presets	46
Sleep Timer	47
Information	48
Calibration	49
Service	56
5. Maintenance and Troubleshooting	67
Maintenance	67
Troubleshooting.....	67

6. External Control	69
Serial Communications	69
RS-232 Connection and Port Configuration	69
Command Format	69
Response Format	70
Command and Response Examples	71
Serial Command List.....	71
Using Discrete IR Codes	84
IR Command Protocol	84
IR Command List.....	86
Using HDMI CEC Messages	88
CEC Command List.....	88
7. Specifications	91
LS-100d Specifications	91
DHD Controller Specifications	93
Overall Dimensions – LS-100d	94
Supported Timings	95

Notes:

List of Figures

2-1. LS-100d Rear/Side/Top View	5
2-2. LS-100d Input Panel	6
2-3. DHD Controller Front Panel	7
2-4. DHD Controller Rear Panel	8
2-5. DHD Controller/LS-100d Remote Control.....	10
3-1. Connecting the LS-100d to the DHD Controller.....	19
3-2. RS-232 Connection from the DHD Controller to the LS-100d.....	20
3-3. HDMI Source Connections	21
3-4. Component Video Source Connections.....	22
3-5. RGBHV Source Connections.....	23
3-6. SCART RGBS Source Connections.....	24
3-7. Composite Video Source Connections	25
3-8. Audio Processor Connection to DHD Controller	26
3-9. RS-232 Control System Connection to DHD Controller	27
3-10. Connecting 12-volt Trigger Outputs.....	28
3-11. External IR Receiver Connection.....	28
3-12. Ethernet Network Connection to DHD Controller	29
3-13. Keystone and Pincushion Distortion	32
3-14. Image Alignment Controls	33
4-1. LS-100d OSD Menu Structure	35
4-2. Typical PLUGE Pattern for Adjusting Brightness	41
4-3. Typical Gray Bar Pattern for Adjusting Contrast.....	42
4-4. Typical Color Bar Pattern for Adjusting Color Saturation and Tint.....	42
4-5. Typical Test Pattern for Adjusting Sharpness.....	44
4-6. Overscan Modes	45
4-7. CIE 1931 Chromaticity Diagram	50
4-8. Effect of PCE Hue and Saturation Controls.....	52
6-1. RC5 Message Format	85
7-1. Overall Dimensions – LS-100d	94

Notes:

1. Introduction

This Owner's Manual describes how to install, set up and operate the Runco LS-100d Ultra Short-Throw LED Home Theater Projector and DHD Controller.

Throughout this manual, the Runco LS-100d Ultra Short-Throw LED Home Theater Projector and DHD Controller are referred to collectively as the "LS-100d."

Runco has prepared this manual to help home theater installers and end users get the most out of the LS-100d.

Runco has made every effort to ensure that this manual is accurate as of the date it was printed. However, because of ongoing product improvements and customer feedback, it may require updating from time to time. You can always find the latest version of this and other Runco product manuals on-line, at www.runco.com.

Runco welcomes your comments about this manual. Send them to support@runco.com.

Text Conventions: The following conventions are used in this manual, in order to clarify the information and instructions provided:

- Remote and built-in keypad button identifiers are set in upper-case bold type; for example, "Press **EXIT** to return to the previous menu."
- Computer input (commands you type) and output (responses that appear on-screen) is shown in monospace (fixed-width) type; for example: "To change the aspect ratio to Letterbox, type `LETTERBOX <Enter>`."
- All keys with functional names are initial-capped, set in bold type and enclosed in angle brackets. These keys are the following: **<Enter>**, **<Spacebar>**, **<Control>**, **<Esc>** and **<Tab>**.
- **<Enter>** indicates that you may press either the RETURN or ENTER key on your keyboard if it has both keys.

In addition to these conventions, underlining, boldface and/or italics are occasionally used to highlight important information, as in this example:



Note

*A carriage return **must** be used after each command or string.*

1.1 About This Manual

◀ Target Audience

◀ If You Have Comments About This Manual...

◀ Textual and Graphic Conventions

Graphic Conventions: These symbols appear in numerous places throughout the manual, to emphasize points that you must keep in mind to avoid problems with your equipment or injury:



Tip

TIPS highlight time-saving short cuts and helpful guidelines for using certain features.



Note

NOTES emphasize text with unusual importance or special significance. They also provide supplemental information.



Caution

CAUTIONS alert users that a given action or omitted action can degrade performance or cause a malfunction.



WARNING

WARNINGS appear when a given action or omitted action can result in damage to the equipment, or possible non-fatal injury to the user.



DANGER!

DANGER appears when a given action can cause severe injury or death.

1.2 Using This Manual

Use the following table to locate the specific information you need in this manual.

If you need...	... Turn to page:
Information about obtaining service	iv
General information about the LS-100d Ultra Short-Throw LED Home Theater Projector and DHD Controller	3
Installation instructions	13
First-time configuration instructions	31
Advanced configuration instructions	49
Troubleshooting tips	67
Product specifications	91

Runco is proud to expand its best-selling LightStyle™ Series projectors, with the new LS-100d with NEAR™ (Next-generation Extreme Aligned Reflection™). This ultra-short throw lens system boldly goes where no projector has ever gone, maximizing the benefits of Runco's InfiniLight lampless LED illumination technology to provide an infinite light source that creates an energy-efficient projector with the widest color gamut ever available in home theater projection.

The LS-100d includes Runco's proprietary Reflex™ Architecture Delivering a stunning 92-inch diagonal image that fits any setting. It combines Runco's unsurpassed performance and a new, clever industrial design that allows installation flexibility with a depth of only 18 inches. The LS-100d mounts flush to the screen wall and can be mounted above or below the screen, with no lamps to replace.

Runco's advanced Vivix™ digital video processing is included to enhance picture quality from standard video sources, as well as provide artifact-free scaling. Also included are discrete input source, aspect ratio, power on/off, HDMI™ input and an RS-232 interface for seamless integration with automation control systems.

The LS-100d offers these key features and benefits:

- Full-HD Native Resolution: 1920 x 1080 (16:9 Native Aspect Ratio)
- InfiniLight™ lampless LED illumination technology provides an infinite, energy-efficient light source
- Fixed NEAR™ lens delivers the industry's shortest throw distance
- Offering the largest color gamut and Runco's Personal Color Equalizer™ proprietary color management for stunning realism
- Four (4) HDMI Inputs (on DHD Controller) with High-bandwidth Digital Content Protection (HDCP)
- HDTV Compatible
- Stylish design with Runco performance, the LightStyle series are designed for both performance and esthetics, that makes transportation and installation easy

Your LS-100d is shipped with the following items. If any items are missing or damaged, please contact your Runco dealer or Runco Customer Service at (800) 23-RUNCO.

- LS-100d Ultra Short-Throw LED Home Theater Projector and DHD Controller
- Remote Control Unit and two (2), AAA-size batteries
- AC Power Cords (2)
- Serial Port Adapter (null-modem), RJ-11 Female to DB-9 Female
- RJ-11 Telephone Cable, 50 feet (15.24 meters)
- HDMI-to-HDMI Cable, sold separately (refer to **Optional Accessories**, below)
- Rack-mount hardware for the DHD Controller
- Runco LS-100d Quick Setup Guide

1.3 Description, Features and Benefits

◀ Key Features and Benefits

◀ Parts List

Optional Accessories:

- Wall/Ceiling mount kit (part number 955-0294-00)
- HDMI-to-HDMI Cable, length specified at time of order:
 - 16.4 feet (5.0 meters) (part number 903-1010-00)
 - 24.6 feet (7.5 meters) (part number 903-1011-00)
 - 32.8 feet (10.0 meters) (part number 903-1012-00)
 - 49.2 feet (15.0 meters) (part number 903-1013-00)
 - 65.6 feet (20.0 meters) (part number 903-1014-00)

2. Controls and Functions

Figure 2-1 shows the key LS-100d components.

2.1 LS-100d at a Glance

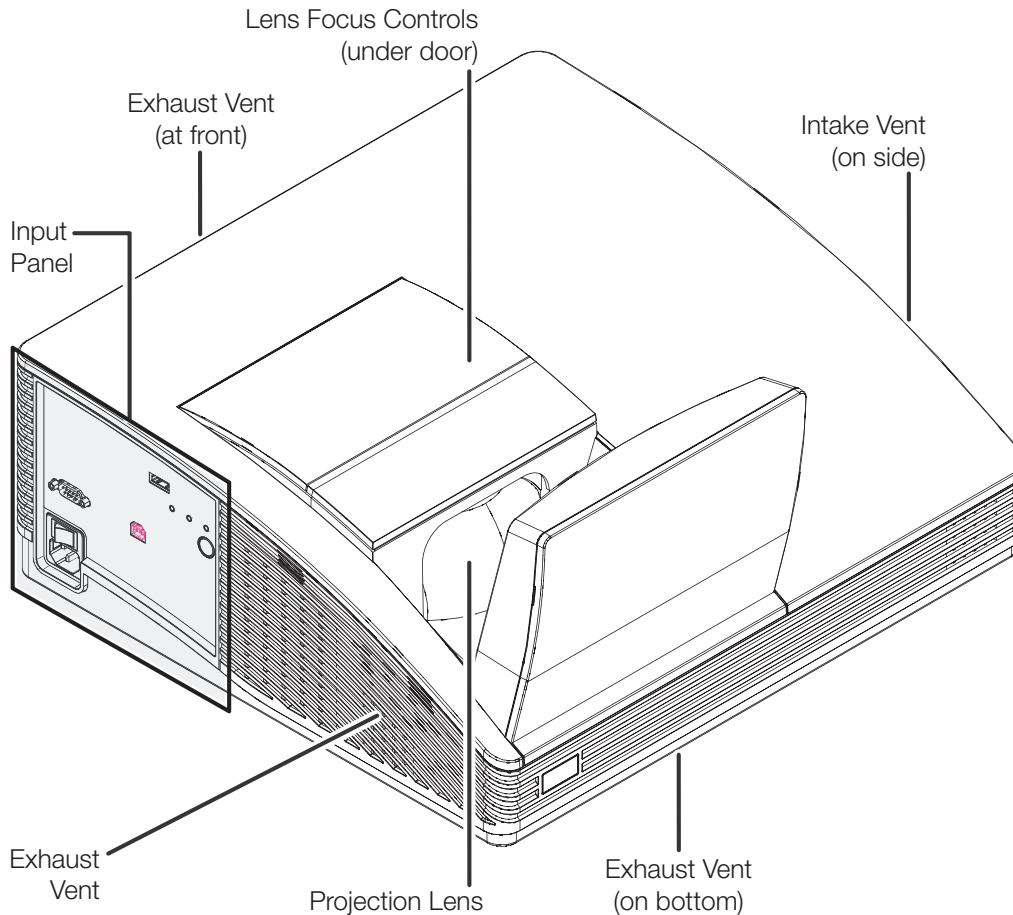

Figure 2-1. LS-100d Rear/Side/Top View

- **INTAKE VENT**
Internal fans draw cool air into the projector through this vent.
- **PROJECTION LENS**
- **EXHAUST VENTS**
Warm air exits the projector through these vents. Ensure that they are not blocked.
- **LENS FOCUS CONTROLS (under door)**
To access the lens focus controls, press down on the door edge closest to the mirror and open the door. For more information, refer to **Lens Focus Adjustment** on page 31.
- **INPUT PANEL**
For more information, refer to **LS-100d Input Panel** on page 6.

2.2 LS-100d Input Panel

Figure 2-2 shows the LS-100d input panel.

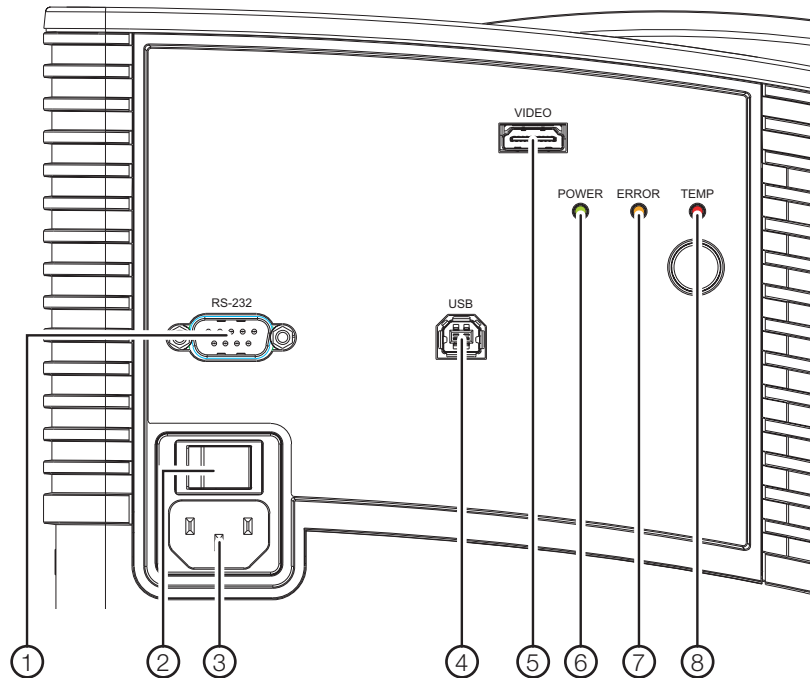
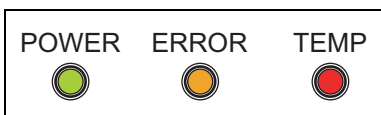

Figure 2-2. LS-100d Input Panel

1. **RS-232C INPUT (9-pin, male D-Sub; null-modem connection)**
Connect the **Display Control** output on the DHD Controller to this input (see Figure 2-4).
2. **MAIN POWER SWITCH**
Disconnects or applies power to the projector.
3. **POWER INPUT (100 to 240 VAC)**
Connect the LS-100d to power here.
4. **USB**
A standard, USB Series "B" connection to a personal computer, for performing software upgrades and other service procedures.
5. **VIDEO**
Connect the **HDMI Out (To Display)** connector on the DHD Controller to this input.
6. **POWER LED**
Indicates projector status as follows:
 - Solid green = AC power present, ready to turn on
 - Flashing green (0.5 seconds on, 0.5 seconds off) = projector is warming up; keypad functions not allowed
 - Flashing green (1 second on, 1 second off) = projector is cooling down; keypad functions not allowed
 - Off = Projector functioning normally



7. ERROR LED

- Solid orange = Error that requires servicing (fan fail, Power-on self-test fail etc.)
- Off = Projector functioning normally

8. TEMP LED

- Solid red = Over temperature, user intervention (clear vents, turn on AC) may fix problem
- Off = Projector functioning normally

Figure 2-3 shows the controls and indicators on the DHD Controller front panel; the paragraphs that follow describe them.

2.3 DHD Controller Front Panel

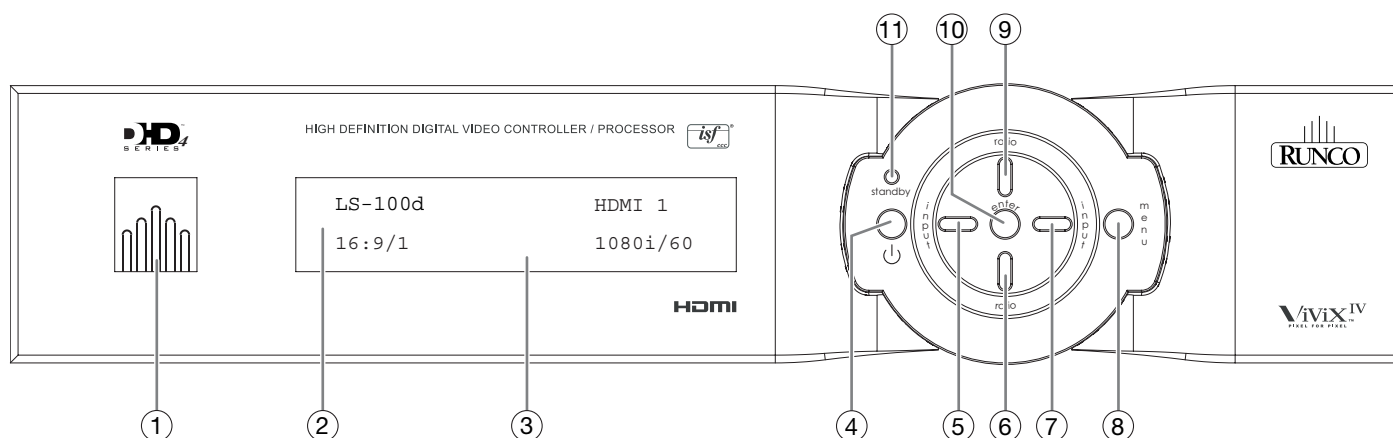

Figure 2-3. DHD Controller Front Panel

- 1. RUNCO ICON**
Lights blue to indicate that the controller is on or powering up.
- 2. IR SENSOR**
Receives IR commands from the remote control.
- 3. VACUUM FLUORESCENT DISPLAY**
Can be used instead of the On-Screen Display (OSD). Displays currently-selected menu or – if no menu is selected – the connected display device model, current source, input resolution and aspect ratio/screen.
- 4. ON/STANDBY BUTTON**
Press once to toggle from standby mode to on mode. Press it again to return to standby mode. For a discrete on or off command, you can use the direct access buttons on the remote control.
- 5. LEFT BUTTON**
Used to direct-select inputs or move the menu cursor left in the OSD. When no menu is present on-screen, the **LEFT** button toggles through the different sources, in this order:
HDMI 4 - HDMI 3 - HDMI 2 - HDMI 1 - SCART - HD 2 - HD 1 - Component - Composite 3 - Composite 2 - Composite 1

6. **DOWN BUTTON**

Use to direct-select aspect ratios or move the menu cursor down in the OSD. When no menu is present on-screen, this button toggles through the different aspect ratios, in this order:

16:9 - 4:3 - Letterbox - VirtualWide - Cinema - Virtual Cinema - Native



Note

For more information about aspect ratios, refer to Table 4-1.

7. **RIGHT BUTTON**

Used to direct-select inputs or move the menu cursor right in the OSD. When no menus are present on-screen, the **RIGHT** button toggles through the different sources, in this order:

Composite 1 - Composite 2 - Composite 3 - Component - HD 1 - HD 2 - SCART - HDMI 1 - HDMI 2 - HDMI 3 - HDMI 4

8. **MENU BUTTON**

Press the **MENU** button to bring up the main menu, or to exit the current menu and return to the previous one.

9. **UP BUTTON**

Use to direct-select aspect ratios or move the menu cursor up in the OSD. When no menus are present on-screen, the **UP** button toggles through aspect ratios in the following order:

Native - Virtual Cinema - Cinema - VirtualWide - Letterbox - 4:3 - 16:9

10. **ENTER BUTTON**

When an item is highlighted on the OSD, the **ENTER** button selects the item.

11. **STANDBY LED**

Lights amber when the DHD Controller is in standby mode; otherwise it is off.

2.4 DHD Controller Rear Panel

Figure 2-4 shows the rear connector panel on the DHD Controller.

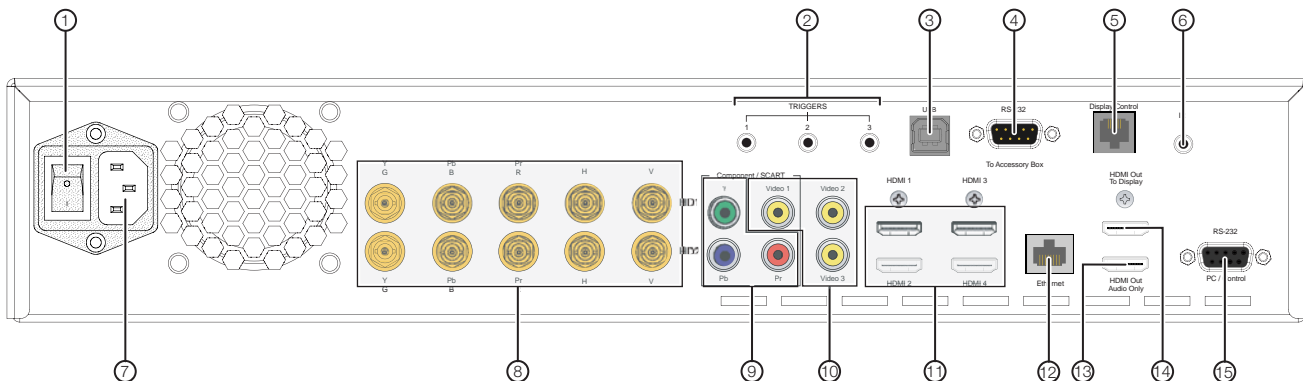

Figure 2-4. DHD Controller Rear Panel

1. **MAIN POWER SWITCH**
Disconnects or applies power to the DHD Controller.
2. **TRIGGERS**
Connection for up to three (3), 12-volt trigger-controlled devices such as retractable screens or screen masks. Output current is limited to 250 milliamperes (mA).
3. **USB**
A standard, USB Series "B" connection to a personal computer, for performing software upgrades and other service procedures.
4. **RS-232 (To Accessory Box)**
A male, 9-pin D-sub connector for interfacing with external equipment. (For future use.)
5. **Display Control**
Connect this to the RS-232 input on the LS-100d projector, using the supplied communication cable and null-modem adapter (refer to **Connecting the DHD Controller to the LS-100d** on page 19).
6. **IR**
Wired input from a Niles- or Xantech-compatible, infrared (IR) repeater system. It is a 3.5-mm, mini phono jack, wired as follows:
Ring = No connection
Tip = IR Input
Sleeve = Ground
7. **POWER INPUT (100 to 240 VAC)**
Connect the DHD Controller to power here.
8. **HD1 / HD2 (5 x Analog BNCs)**
Two inputs (five BNCs per input) for connecting standard-definition (SD = 480i/576i), enhanced-definition (ED = 480p/576p) or high-definition (HD = 720p/1080i/1080p) component video sources, or RGBHV sources such as personal computers.
9. **Component / SCART (3 x RCA connectors)**
SD/HD input for connecting SDTV, EDTV or HDTV component video sources. Also provides RGB input for SCART RGBS sources.
10. **Video 1 / Video 2 / Video 3**
Standard, composite video inputs for connecting a VCR, camcorder or other composite video source. The Video 1 input also provides composite sync input for SCART RGBS sources.
11. **HDMI 1 / HDMI 2 / HDMI 3 / HDMI 4 (Digital)**
HDCP-compliant digital video inputs for connecting an HDMI or DVI source.
12. **Ethernet**
A female RJ-45 connector for wired network communications.
13. **HDMI Out (Audio Only)**
Connect this output to an audio control system to pass through HDMI audio.
14. **HDMI Out (To Display)**
Connect this to the **DHD Input** on the LS-100d (see Figure 2-2).
15. **RS-232 (PC / Control)**
A female, 9-pin D-sub connector for interfacing with a PC or automation/control system.

2.5 LS-100d Remote Control Unit

Figure 2-5 shows the LS-100d remote control, and the paragraphs that follow describe its functionality.

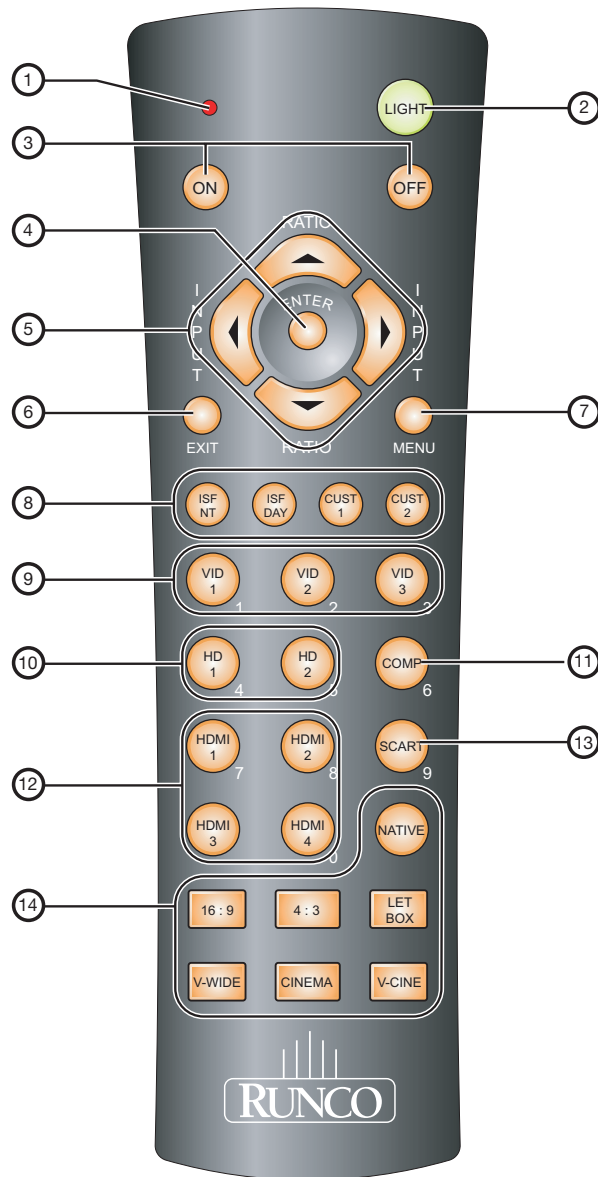

Figure 2-5. DHD Controller/LS-100d Remote Control

1. **IR OUTPUT INDICATOR**
Lights when a button is pressed to indicate that an IR signal is being transmitted.
2. **LIGHT**
Press to illuminate the buttons.
3. **ON / OFF**
Press to turn the DHD Controller and projector on or off.
4. **ENTER**
Press to select a highlighted menu item or confirm a changed setting.
5. **Cursor Buttons (▲, ◀, ▼, ▶)**
Use these buttons to select items or settings, adjust settings or switch display patterns.

When no menu is present on-screen, the **UP** and **DOWN** buttons toggle through the available aspect ratios, in this order:

UP Button = Native - Virtual Cinema - Cinema - VirtualWide - Letterbox - 4:3 - 16:9

DOWN Button = 16:9 - 4:3 - Letterbox - VirtualWide - Cinema - Virtual Cinema - Native



Note

For more information about aspect ratios, refer to Table 4-1.

Likewise, the **LEFT** and **RIGHT** buttons toggle through the different source inputs, in this order:

LEFT Button = HDMI 4 - HDMI 3 - HDMI 2 - HDMI 1 - SCART - HD 2 - HD 1 - Component - Composite 3 - Composite 2 - Composite 1

RIGHT Button = Composite 1 - Composite 2 - Composite 3 - Component - HD 1 - HD 2 - SCART - HDMI 1 - HDMI 2 - HDMI 3 - HDMI 4

6. **EXIT**
Press this button to exit the current menu and return to the previous one.
7. **MENU**
Press this button to access the OSD controls, or to exit the current menu and return to the previous one.
8. **Memory Preset Buttons:**
 - ISF NIGHT**
Press to recall settings for the current input from the "ISF Night" memory preset.
 - ISF DAY**
Press to recall settings for the current input from the "ISF Day" memory preset.
 - CUST 1**
Press to recall settings for the current input from the "Custom 1" memory preset.
 - CUST 2**
Press to recall settings for the current input from the "Custom 2" memory preset.
9. **VID 1 (1) / VID 2 (2) / VID 3 (3)**
Press to select a composite video input as the source or to enter the numeric character "1," "2" or "3."

10. **HD 1 (4) / HD 2 (5)**

Press to select a HD (RGBHV or YPbPr component) input or to enter the numeric character "4" or "5."

11. **COMP (Component) (6)**

Press to select the Component video input as the source or to enter the numeric character "6."

12. **HDMI 1 (7) / HDMI 2 (8) / HDMI 3 / HDMI 4 (0)**

Press to select an HDMI input as the source or to enter the numeric character "7," "8" or "0."

13. **SCART (9)**

Press to select the SCART video input as the source or to enter the numeric character "9."

14. **Aspect Ratio Selection Buttons**

Use these buttons to select an aspect ratio directly, as follows:

NATIVE

Displays the source signal in its native resolution, centered in the display area.

16:9

For viewing 16:9 DVDs or HDTV programs in their native aspect ratio.

4:3

Scales the input signal to fit 4:3 display mode in the center of the screen.

LETBOX (Letterbox)

For viewing non-anamorphic ("full-screen") DVDs on a 16:9 screen.

V-WIDE (VirtualWide)

Enlarges a 4:3 image horizontally in a non-linear fashion to fit 16:9 full screen display.

CINEMA

For viewing 2.35:1 source material.

V-CINE

Selects the Virtual Cinema aspect ratio, used for viewing 16:9 source material on a 2.35:1 screen.

3. Installation



Note

Installation **must** be performed by a qualified custom video installation specialist.

To install batteries in the remote control:

1. Press down the tab on the cover and pull the cover in the direction of the arrow.
2. Insert the included batteries. Ensure that the polarities correctly match the \oplus and \ominus markings inside the battery compartment.
3. Insert the lower tab of the cover into the opening, and press down the cover until it clicks in place.

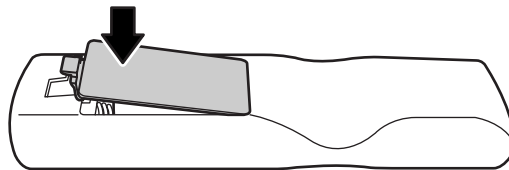
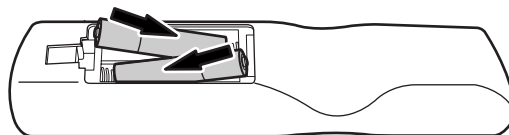
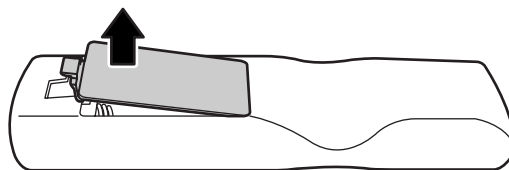

- Make sure that the battery polarities are correct when installing the batteries.
- Do not mix an old battery with a new one or different types of batteries.
- If you will not use the remote control for a long time, remove the batteries to avoid damage from battery leakage.
- Do not expose batteries to excessive heat such as from sunshine, fire or the like.
- Make sure that there is nothing obstructing the infrared beam between the remote control and the IR receiver on the DHD Controller.
- If the effective range of the remote control decreases, or it stops working, replace the batteries with new ones.
- The remote control may fail to operate if the infrared remote sensor is exposed to bright sunlight or fluorescent lighting.
- Ambient conditions may possibly impede the operation of the remote control. If this happens, point the remote control at the DHD Controller, and repeat the operation.

3.1 Remote Control

◀ Notes on Batteries

◀ Notes on Remote Control Operation

3.2 Quick Setup

Table 3-1 gives a quick overview of the LS-100d installation process. The sections following this one provide detailed instructions.

Table 3-1. Installation Overview

Step	Procedure	For Details, Refer to page...
1	Choose a location for the projector	15
2	Mount the projector	18
3	Connect the DHD Controller to the projector	19
4	Connect signal sources to the DHD Controller	21
5	Connect other external equipment to DHD Controller (optional): <ul style="list-style-type: none"> • Audio processor or secondary display device • Automation/control system (RS-232) • 12-volt trigger-activated equipment • External IR repeater • Network hub, router or gateway (Ethernet) 	27
6	Connect projector and DHD Controller to AC power and power up	29
7	Adjust lens focus	31
8	Select the proper picture orientation	31
9	Use the Image Alignment controls to fine-tune image geometry	32
10	Display calibration: adjust the following for each input and display mode (resolution and frame rate); save settings when finished: <ul style="list-style-type: none"> • Aspect ratio • Brightness • Contrast • Color level • Tint • Sharpness • White Balance 	37

Proper installation of your projector will ensure the quality of your display. Whether you are installing a projector temporarily or permanently, you should take the following into account to ensure your projector performs optimally.

To maximize image quality, ensure that the screen you intend to use with the LS-100d meets the following requirements:

- **Width:** Must be between 77" (1.96 meters) and 86" (2.18 meters) in width.
- **Must Be Flat:** Roll-down screens will not work. The LS-100d throw ratio, which is approximately 0.2:1, means that anything even slightly out of flat will cause major distortions in the image. For example, a depth change of 0.5 inches would mean the image would warp by 2.5 inches.
- **Must Not Move:** The structure between the projector and the screen needs to be very stable to prevent the image from warping a lot. Since any fine adjustments should be done by the installer, this means that the screen cannot move relative to the projector.
- **Must Be a Diffuse Surface (reflects in all directions equally):** Typically this means a white, 1.0 gain screen or something very close to this. Adding any gain makes the screen more reflective which in turn due to the steep angles results in the light from the projector hitting the ceiling, rather than the viewer. Adding gain makes the image dimmer.
- **The Screen Frame Must Be Beveled:** The steep angle of the projection could vignette on some screen frames (such as square ones). Typical higher-end screens typically do work fine as they have a beveled edge.

In general, minimize or eliminate light sources directed at the screen. Contrast ratio in your images will be noticeably reduced if light directly strikes the screen, such as when a shaft of light from a window or floodlight falls on the image. Images may then appear washed out and less vibrant.

3.3 Installation Considerations

◀ **Screen Requirements**

◀ **Ambient Light**

Rear Projection ➤ The LS-100d cannot be used in rear-projection applications.

Projection Distance and Image Size ➤ Table 3-2 gives the projection distance and image size ranges for the LS-100d.

Table 3-2. LS-100d Projection Distance and Image Size Ranges

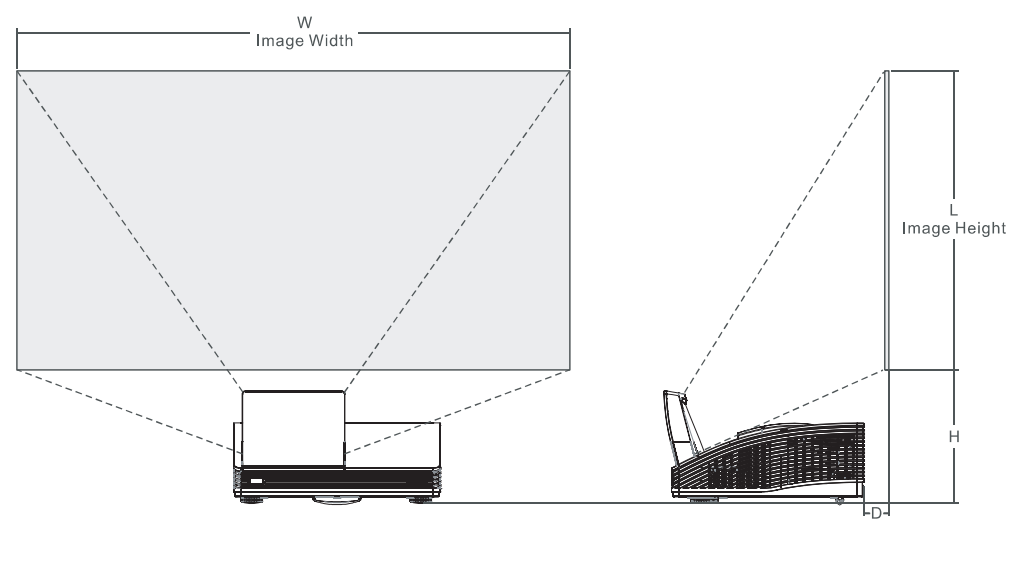

	Minimum	Maximum
Projection Distance (D)	0.28 in. (7.2 mm)	1.87 in. (47.6 mm)
Image Height (L)	43.44 in. (1103.3 mm)	48.56 in. (1233.5 mm)
Distance from bottom of projector feet to bottom edge of image area (H)	15.55 in. (395.0 mm)	17.08 in. (434.0 mm)
Image Width (W)	77.22 in. (1961.4 mm)	86.33 in. (2193.0 mm)
Screen Diagonal Measure	88.50 in. (2247.9 mm)	99.00 in. (2514.6 mm)

Note: To precisely determine the correct projector location (**H** and **D** in the above diagram), based on the desired image height (**L**), use the following formula:

$H = 0.3 * L + 2.54 \text{ in. (64.5 mm)}$ to bottom of projector feet
 $H = 0.3 * L + 2.00 \text{ in. (50.7 mm)}$ to mount bosses
 $D = 0.31 * L - 13.19 \text{ in. (335.1 mm)}$

To accommodate typical installation tolerances, Runco recommends the following procedure:

1. Take the screen size you're going to use and add 2.0 inches (50 mm) to the height and 3.56 inches (89 mm) to the width symmetrically about the center of the image.
2. Use the information in Table 3-2 to determine the installation requirements based on this larger screen size.
3. When the projector is installed and powered on, the image will appear "over-scanned" on the edges of your screen. Use the Image Alignment controls to bring the edges of the image in line with your screen; refer to **Adjusting the Image Geometry** on page 32 for detailed instructions.

Due to its extraordinarily high level of video processing performance, the DHD Controller may distribute video signals with a perceptible level of audio latency. In order to easily solve this issue, Runco recommends using the DHD Controller with a high-quality audio receiver that has the ability to effectively synchronize audio and video signals.

Most mainstream audio receiver/switchers have the ability to synchronize the audio and video to the Advanced Television Systems Committee (ATSC) prescribed tolerances. According to the ATSC, the sound program should never lead the video program by more than 15 milliseconds, and should never lag behind the video program by more than 45 milliseconds.

In addition, many video displays and A/V receivers introduce additional latency that needs to be compensated for during the installation. Table 3-3 shows the amount of possible audio latency given different signal input timings.

Table 3-3. Possible Audio Latency for Various Input Timings

Input Timing	Possible Audio Latency (milliseconds)
480i	133
480p	83
576i	160
576p	100
720p/50	100
720p/60	83
1080i/25	160
1080i/30	133
1080p/24	125
1080p/50	80
1080p/60	67

Other considerations and tips that can help improve your installation:

- Keep the ambient temperature constant and below 35°C (95°F). Keep the projector away from heating and/or air conditioning vents. Changes in temperature may cause drifts in the projector circuitry, which may affect performance.
- Keep the projector away from devices that radiate electromagnetic energy such as motors and transformers. Common sources of these include slide projectors, speakers, power amplifiers and elevators.

◀ **Audio/Video Synchronization Issues**

◀ **Other Considerations**

3.4 Mounting the LS-100d

There are several methods for mounting the projector. Depending on your chosen installation, one method may be more suitable than another.

- Floor Mounting (Upright)** ➤ The projector can be placed on a secure, level surface such as a table or cart. Carts are useful when moving a projector during a presentation or from site to site. If possible, lock the wheels when it's in position to prevent it from being moved during a presentation.
- Wall or Ceiling Mounting** ➤ For fixed installations, you can attach the LS-100d to the ceiling or nearest wall using a specially-designed mounting fixture.



Note

Use only the Runco-approved ceiling mount kit designed for this projector. Install the mount kit according to the instructions provided with it.

- Adjusting the Projection Angle** ➤ If the LS-100d is ceiling-mounted and the screen is significantly lower than the projector, you can tilt the projector at a slight angle by adjusting the ceiling mount.

If you do this, you may need to shift the image using the on-screen display (OSD) controls, to compensate. For detailed instructions, refer to **Using the On-Screen Menus** on page 35.

Proceed as follows to connect the DHD Controller to the LS-100d, your video sources, external controller(s) – if present – and AC power.

When connecting your equipment:

- Turn off all equipment before making any connections.
- Use the correct signal cables for each source.
- For best performance and to minimize cable clutter, use high-quality cables that are only as long as necessary to connect two devices. (Don't use a 20-foot cable when a 6-foot cable will suffice.)
- Ensure that the cables are securely connected. Tighten the thumbscrews on connectors that have them.

Digital Video Connection: Connect the HDMI Output of the DHD Controller to the DHD Input of the LS-100d as shown in Figure 3-1.

3.5 Connections to the LS-100d and DHD Controller

◀ Connecting the DHD Controller to the LS-100d

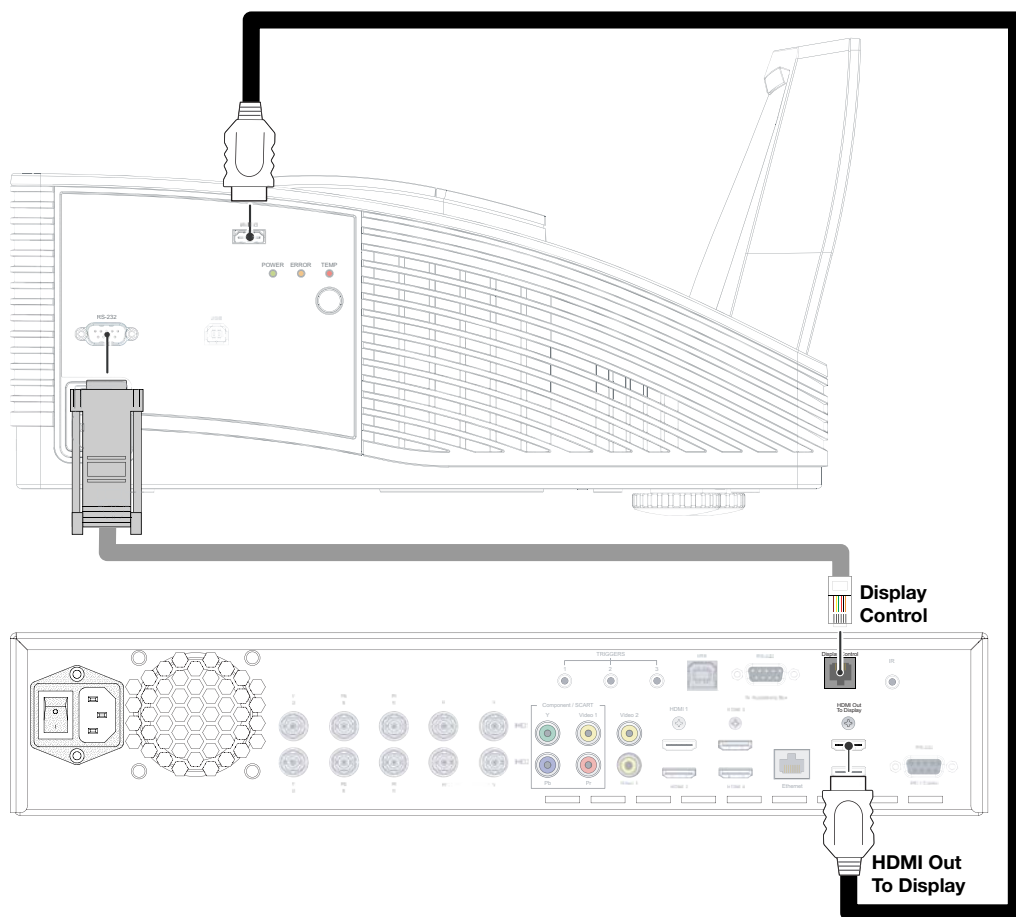

Figure 3-1. Connecting the LS-100d to the DHD Controller

RS-232 Connection: Connect the **Display Control** output from the DHD Controller to the **RS-232** input on the LS-100d. Use a standard, modular telephone cable with RJ11 plugs at both ends. On the LS-100d end, use the provided RJ11-to-DB9 null-modem adapter. This adapter is wired as shown in Figure 3-2.

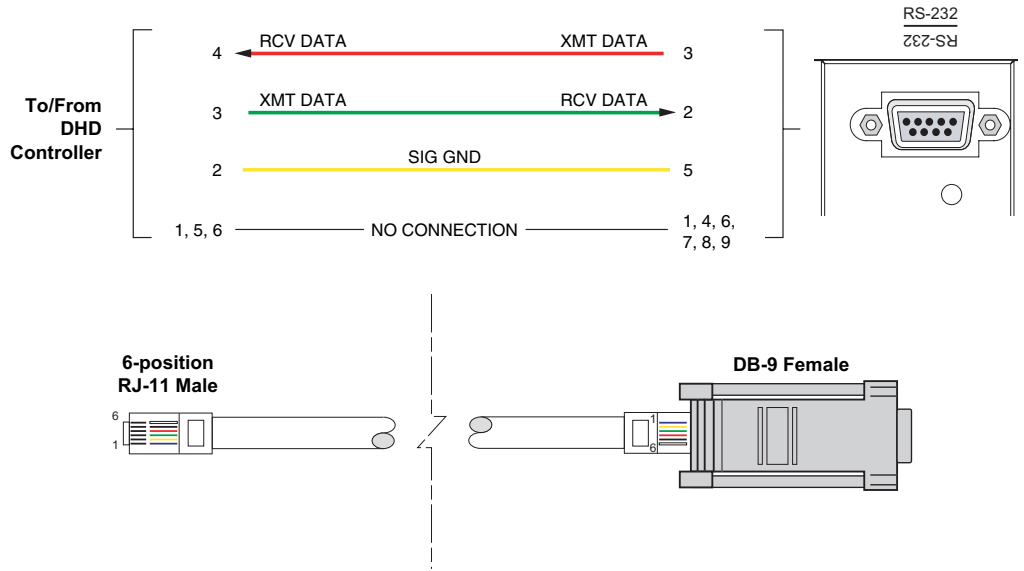

Figure 3-2. RS-232 Connection from the DHD Controller to the LS-100d

Connect your video sources to the DHD Controller as shown and described in the sections that follow.

◀ **Connecting Source Components to the DHD Controller**

HDMI Source Connections: See Figure 3-3.



Tip

Use the HDMI inputs whenever possible. This ensures the highest video quality because the signal is carried in the digital domain throughout the entire signal path, from source component output into the projector.



Note

You can also connect computers with DVI output to these inputs. Refer to **Supported Timings** on page 95 for a list of compatible input signals.

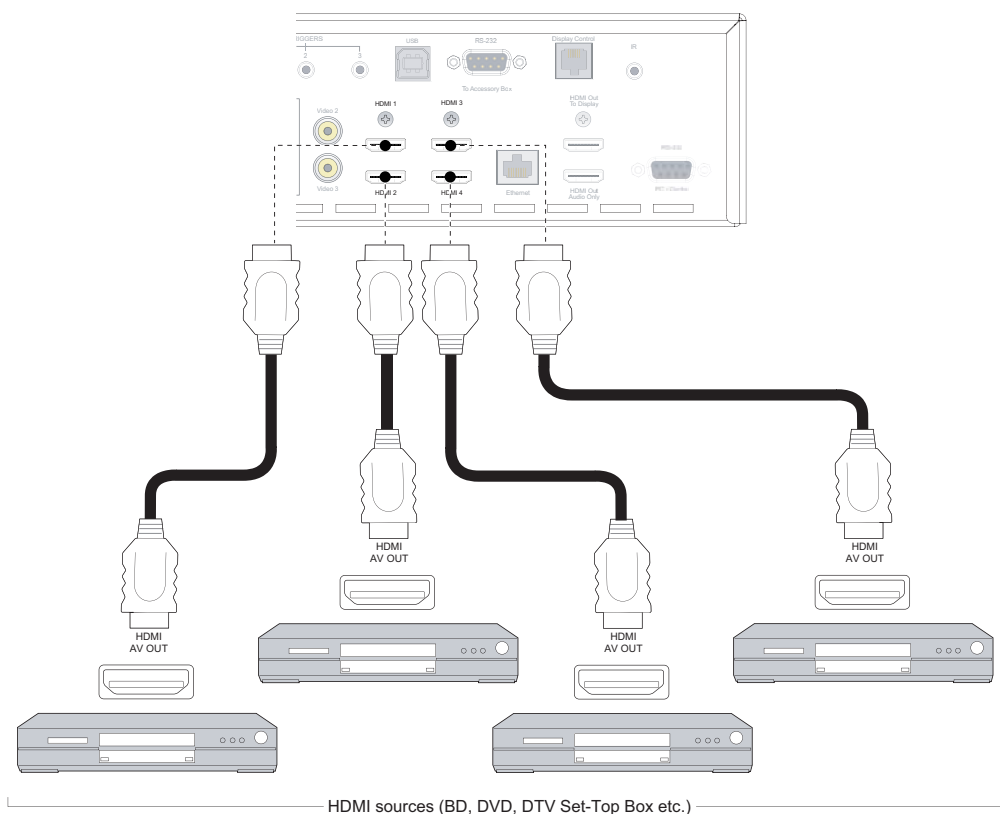

Figure 3-3. HDMI Source Connections

Component Video Source Connections: Connect your component video sources to the HD1, HD2 and/or Component/SCART inputs as shown in Figure 3-4.

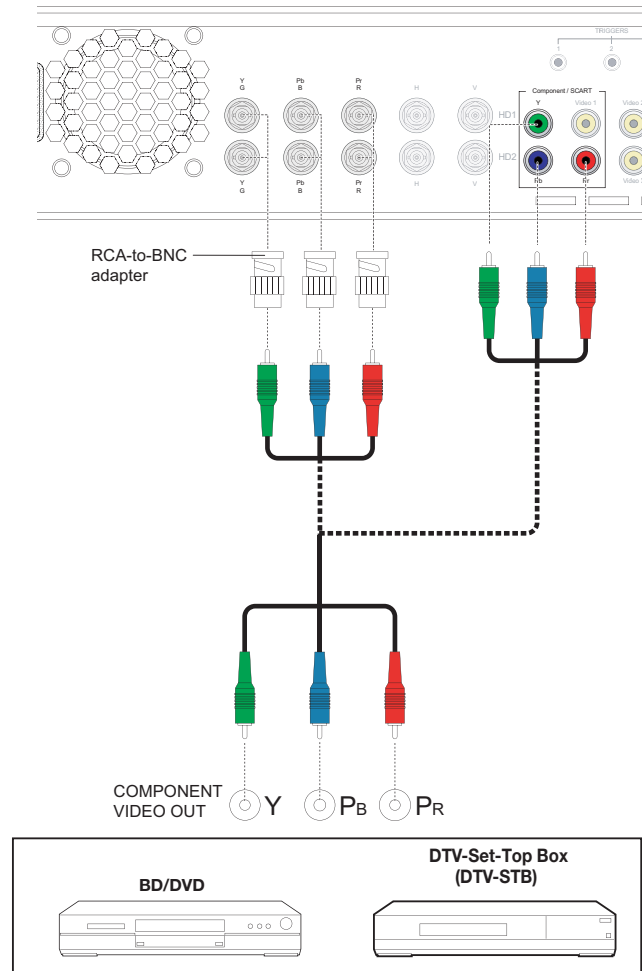

Figure 3-4. Component Video Source Connections

RGBHV Source Connections: Connect personal computers and/or other RGB sources to the HD1 and/or HD2 inputs as shown in Figure 3-5.

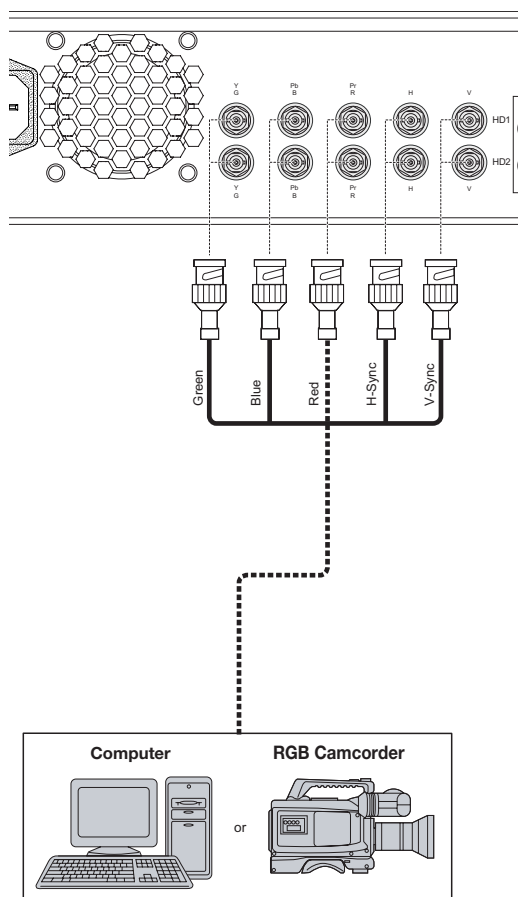

Figure 3-5. RGBHV Source Connections

SCART RGBS Source Connections: Connect the green, blue and red outputs from your SCART source to the Component/SCART input on the DHD Controller. Connect the sync output from your SCART source to the **Video 1** input on the DHD Controller. See Figure 3-6.

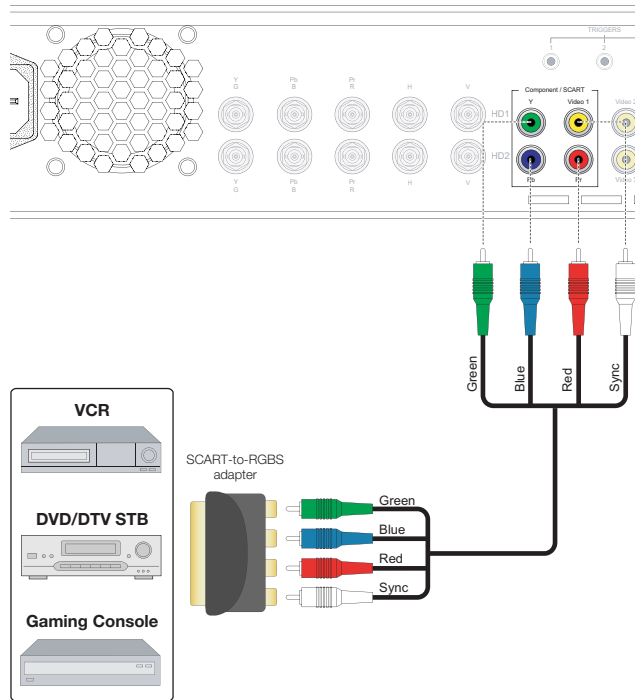

Figure 3-6. SCART RGBS Source Connections

Composite Source Connections: See Figure 3-7.

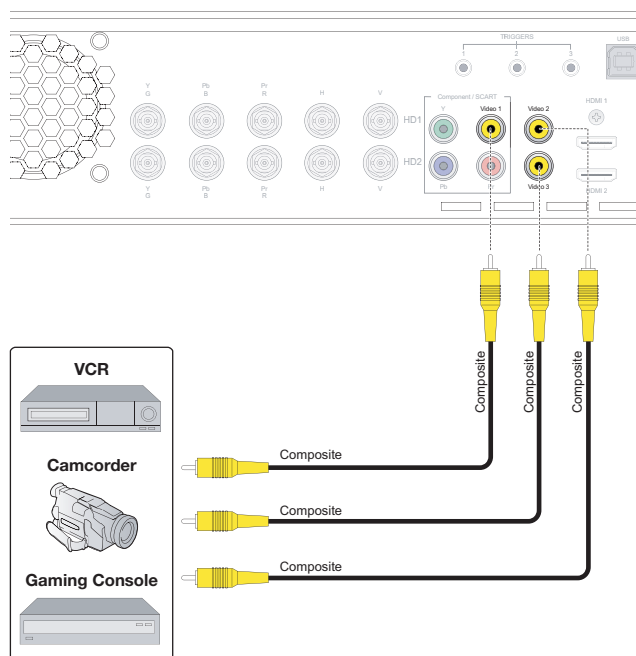

Figure 3-7. Composite Video Source Connections

Connecting an Audio Processor or Secondary Display Device to the DHD Controller (Optional)

The DHD Controller provides a second HDMI output (labeled **HDMI Out (Audio Only)**) for connection to an audio receiver/switching system or secondary display device for monitoring purposes. See Figure 3-8.



Note

*The DHD Controller does not transmit HDMI CEC control messages from the "HDMI Audio Out" connector. For more information about CEC, refer to **Using HDMI CEC Messages** on page 88.*

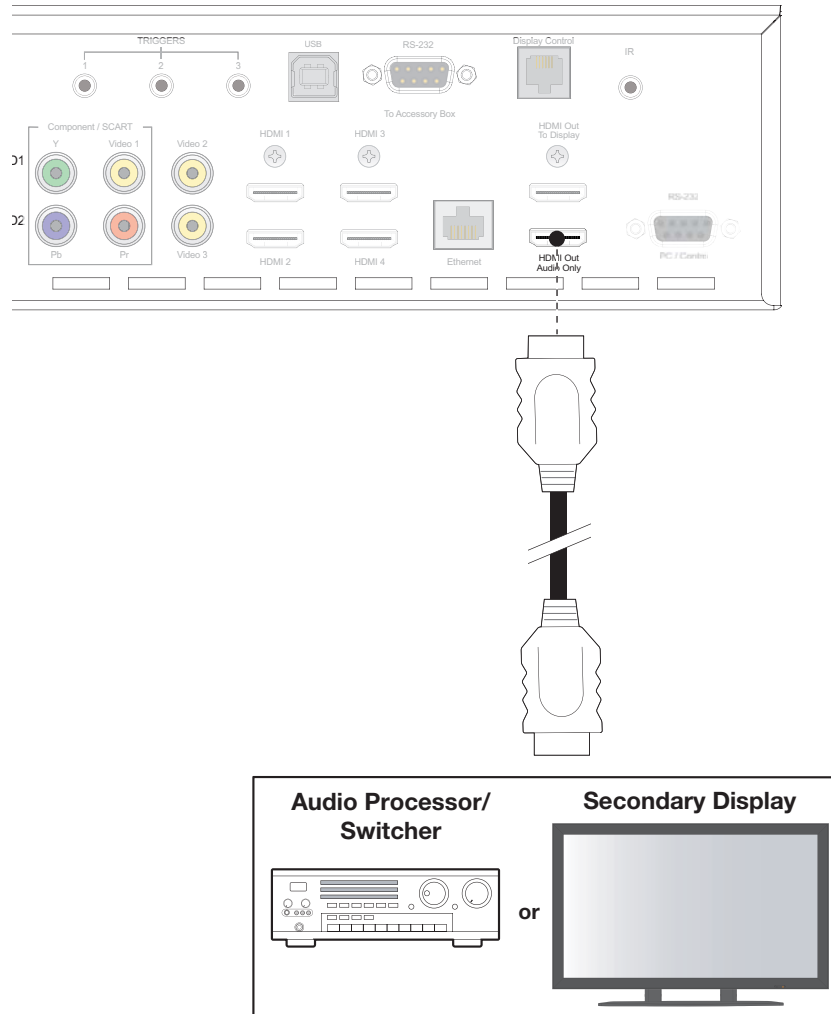

Figure 3-8. Audio Processor Connection to DHD Controller

The DHD Controller provides the following interfaces to external equipment that allow it to control or be controlled by that equipment:

- An RS-232 interface to a PC or control/automation system;
- Three (3), 12-volt trigger outputs;
- An infrared (IR) repeater input;
- An Ethernet network interface for firmware updates and maintenance notifications.

◀ **Additional Connections to the DHD Controller (Optional)**

The following sections describe how to make these interface connections. For more information about using these connections, refer to **Network** on page 58 and **External Control** on page 69.

RS-232 Controller Connection: Use a straight-through, 9-pin RS-232 cable to connect a PC or control/automation system (if present) to the RS-232 port on the DHD Controller; see Figure 3-9.

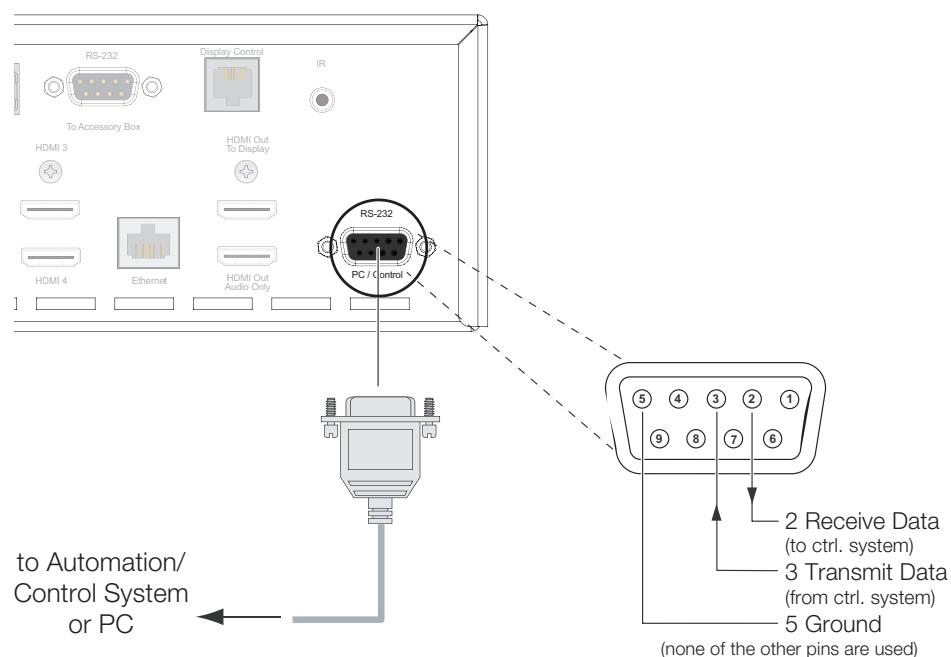

Figure 3-9. RS-232 Control System Connection to DHD Controller

Connecting 12-volt Trigger Outputs to External Equipment: If your home theater contains a screen mask or other 12-volt trigger-activated equipment, connect it to the 12-volt trigger outputs as shown in Figure 3-10.

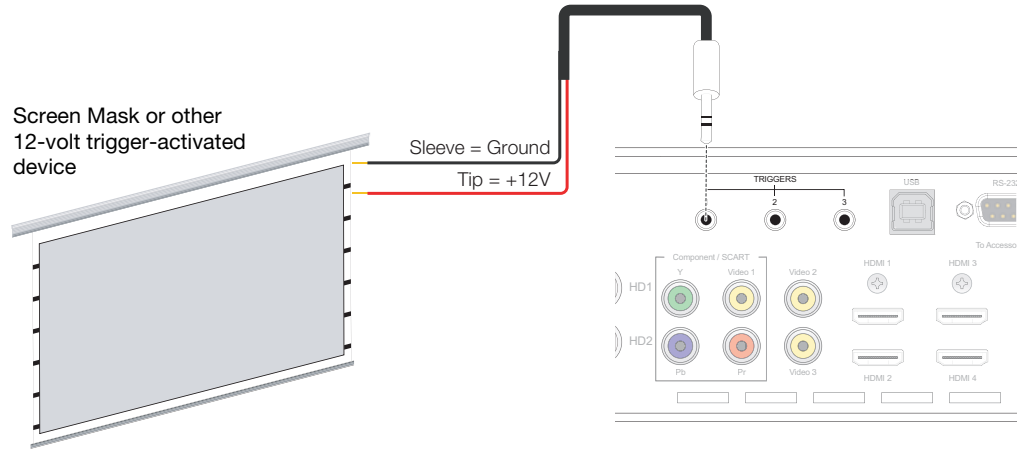

Figure 3-10. Connecting 12-volt Trigger Outputs

Connecting an External IR Receiver to the DHD Controller: If infrared signals from the remote control cannot reach the DHD Controller due to excessive distance or obstructions such as walls or cabinet doors, you can connect an external IR receiver to extend the range of the remote control. See Figure 3-11.

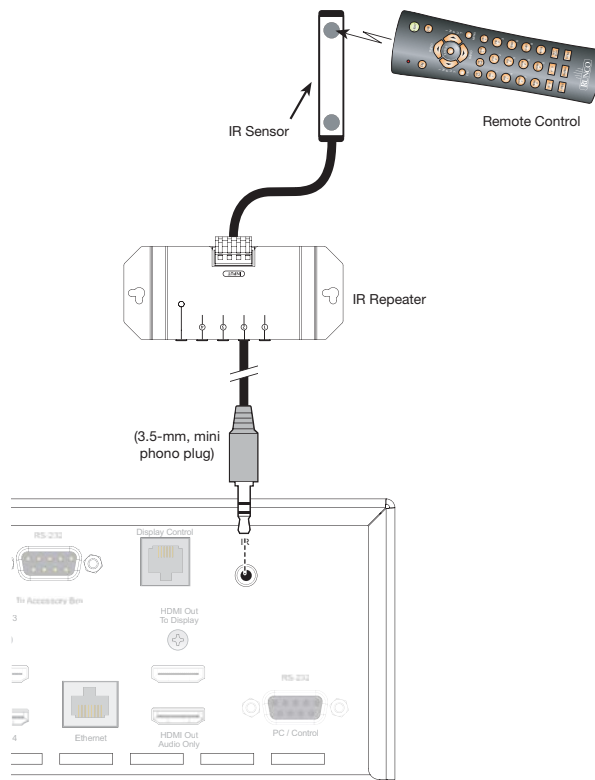

Figure 3-11. External IR Receiver Connection

Ethernet Network Connection: Use a standard, Category 5 network cable with an RJ-45 plug to connect a network hub, router or gateway to the Ethernet port on the DHD Controller; see Figure 3-12. For more information about configuring and using this connection, refer to **Network** on page 58.

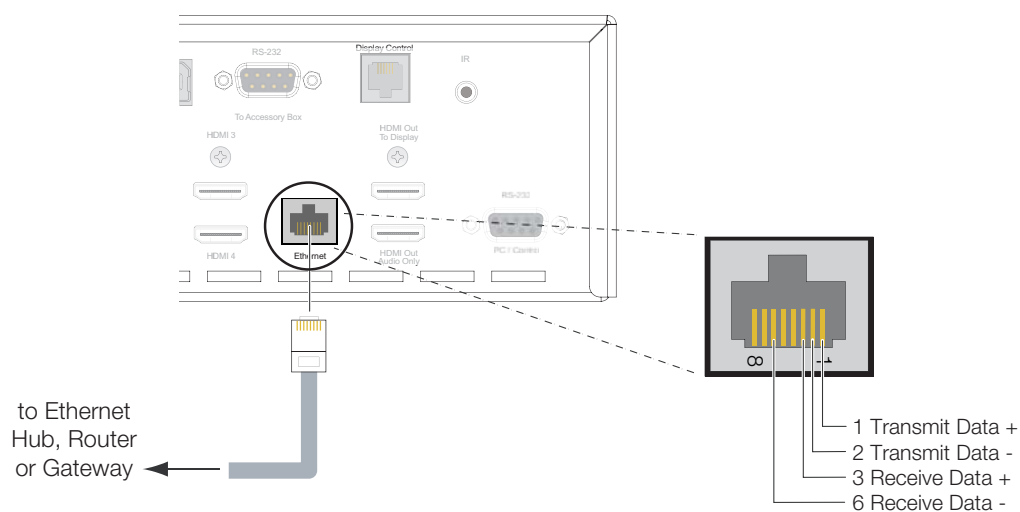

Figure 3-12. Ethernet Network Connection to DHD Controller

Projector/DHD Controller: Plug the female end of one power cord into the AC receptacle on the rear of the LS-100d (AC 100V ~ 240V). Then, connect the other end to your AC power source.

Similarly connect the DHD Controller to a nearby AC outlet.

◀ Connecting to AC Power

3.6 Turning on the Power

1. Turn on your source components.
2. Turn on the main power switch at the rear of the DHD Controller.
3. Press the **ON** button on the remote control (or the **ON/STANDBY** (⏻) button on DHD Controller front panel) to turn on the system. The vacuum fluorescent display on the DHD Controller front panel briefly displays “Initializing System,” followed by “Starting LS-100d.” On the projector, the POWER LED rapidly flashes green to indicate that it is warming up.
4. When the projector is ready for use, the POWER LED lights solid green. On the DHD Controller, the fluorescent display indicates the active source, input resolution/frame rate and aspect ratio/screen; for example:

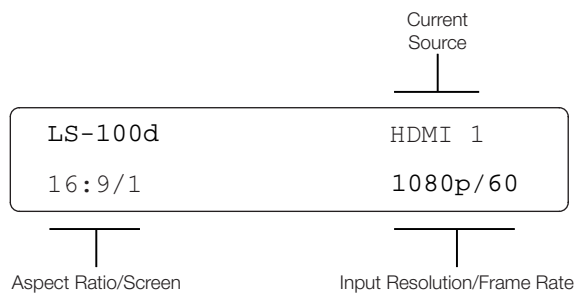

The LS-100d lens focus controls are located beneath a hinged door on the top of the projector. To access them, press down on the door edge closest to the mirror and open the door.



Use the Coarse Focus Adjust dial to adjust the focal length in large increments. Use the Fine Focus Adjust dial to adjust the focal length in small increments.

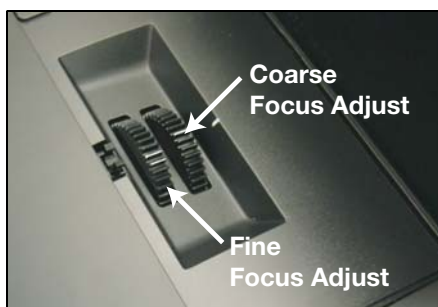

3.7 Lens Focus Adjustment



Note

The two focus controls are interactive, so you may need to adjust each one multiple times to produce a fully-focused image.

By default, the LS-100d is configured for a “floor/front” installation, in which the projector is installed upright and in front of the screen. If it is mounted on a ceiling, you must change the picture orientation. To do this:

1. On the DHD Controller remote control or front panel, press **MENU**.
2. Select **Service** from the Main Menu and enter the Service Menu passcode.



Note

You must enter a passcode to access the Service menu.

3. Select **Display Device** from the Service Menu.
4. Select **Configure** from the Display Device menu, then select **Installation**.
5. Select **Orientation**, then choose Ceiling/Front, to match the installation method. Or, for front-projection installations, use the **Auto** setting to have the projector automatically determine the orientation (floor or ceiling) using an internal sensor.

3.8 Adjusting the Picture Orientation

3.9 Adjusting the Image Geometry

Projector and/or screen placement — among other things — can cause geometric distortion in the projected image.

To correct this, the DHD Controller provides precise, nine-point control over the projected image geometry. Use these controls as (and **only if**) needed to re-position the image corners, mid-points and center to eliminate “keystoning” (mis-aligned corners) or “pincushion” distortion (mid-points not aligned with corners). See Figure 3-13.

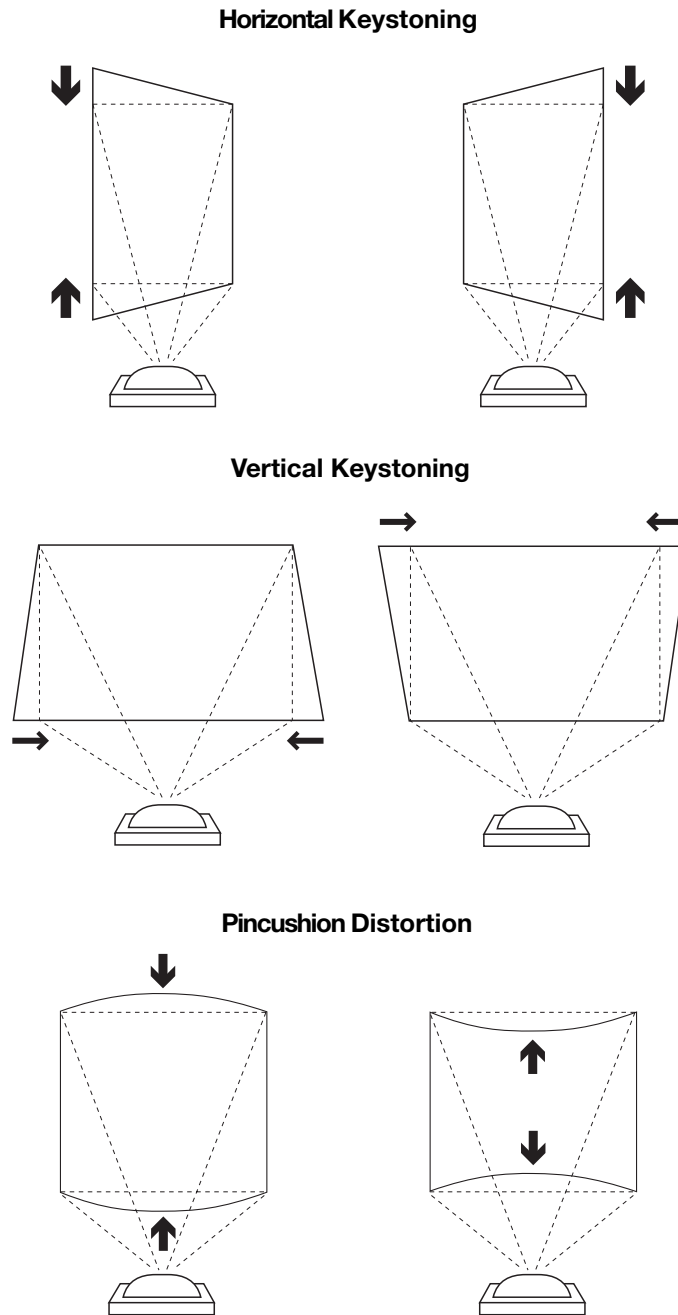

Figure 3-13. Keystone and Pincushion Distortion

“Keystoning” usually occurs when the projector is tilted relative to the screen. “Pincushion” distortion can sometimes occur if the throw distance is very short and/or the projector is equipped with an anamorphic lens.

To correct keystoning or pincushion distortion:

1. On the DHD Controller remote control or front panel, press **MENU**.
2. Select **Calibration** from the Main Menu and enter the Calibration Menu passcode.



Note

You must enter a passcode to access the Calibration menu.

3. Select **Image Alignment** from the Calibration Menu.
4. Select **Corner Alignment** to correct a “keystoned” image by adjusting the image corner positions. Select **Midpoint Alignment** to correct pincushion distortion by adjusting the image edge mid-points. See Figure 3-14.

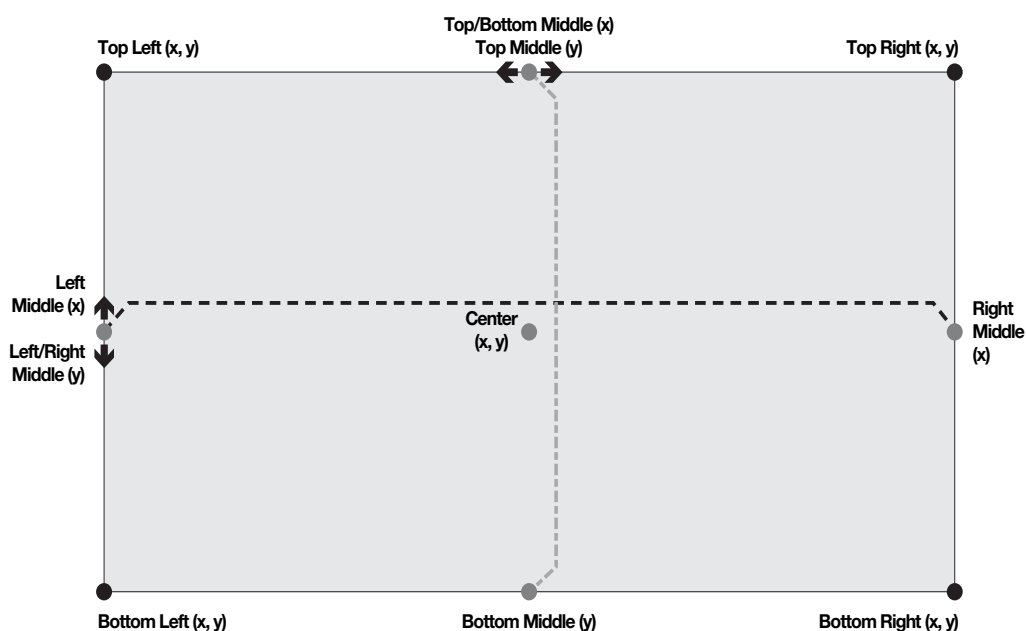

Notes:

1. Smaller “x” values move a point to the left; larger values move it to the right.
2. Smaller “y” values move a point up; larger values move it down.

Figure 3-14. Image Alignment Controls

Notes:

4. Operation

To display the Main Menu, press the **MENU** button on the remote control (Figure 2-5) or DHD Controller front panel (Figure 2-3).

To select a menu item, use the **▲** and **▼** buttons on the remote control or DHD Controller front panel to highlight it. Then, to confirm your selection, press **ENTER** on the remote control or DHD Controller front panel.

The DHD Controller OSD menus are arranged hierarchically, as shown in Figure 4-1. Depending on the selected input source and signal characteristics, some menu options may not be available.

4.1 Using the On-Screen Menus

Input Source	Composite 1	Calibration	Display Color - Common Settings	Gain	-100, -99... 0 ... 99, 100 (Red, Green, Blue)	
	Composite 2			Offset		
	Composite 3			Gamma	Mode	(Simple / Advanced)
	Component				Simple	(1.8, 2.0, 2.2 , 2.35, 2.5)
	HD 1				Advanced	(0 (2.2 gamma curve), 1, 2, 3 ... 20 (custom gamma tables))
	HD 2			Color Temp	Simple	(5500K, 6500K , 7500K or 9300K)
	SCART			Color Gamut	Auto, REC709, SMPTE-C, EBU, Native DCI or PCE	
	HDMI 1			PCE	Hue (Red / Yellow / Green / Cyan / Blue / Magenta)	
	HDMI 2				Saturation (Red / Yellow / Green / Cyan / Blue / Magenta)	
HDMI 3	Level (Red / Yellow / Green / Cyan / Blue / Magenta)					
HDMI 4	White Balance (Red / Green / Blue Gain)					
Aspect Ratio	16:9		Display Color - Projector Settings	SatCo	Off , Low or High	
	4:3		Input Image	Brightness		
	Letterbox			Contrast		
	VirtualWide			Color	-50, -49 ... 0 ... 49, 50	
	Cinema			Tint		
	Virtual Cinema		Sharpness			
Native	Input Color		Gain	-32, -31... 0 ... 31, 32		
Screen			Screen 1 / Screen 2	Offset	(HD 1, HD 2 and Component inputs only)	
			Picture	Brightness		
	Contrast					
Color						
Input Position	Phase (RGB/Component/SCART signals only)	Chroma Delay	0 , 1, 2 ... 7			
	Tracking (RGB/Component/SCART signals only)	Noise Filter	0 , 1, 2 ... 63			
	Left/Right	Save ISF Night	Back / Confirm			
	Up/Down	Save ISF Day				
	Width	Copy/Paste	Memory Preset	Copy Settings		
	Height		Aspect Ratio	Paste Settings		
Overscan	Output Shift	Left/Right	-50, -49 ... 0 ... 49, 50			
Overscan Mode (Zoom/Crop)		Up/Down				
Width		Width	-50, -49, 48 ... 0			
Height		Height				
Phase (RGB/Component/SCART signals only)	Screen Masking	0 , 1, 2 ... 100	(Top / Bottom / Left / Right / Test Pattern Enable)			
Tracking (RGB/Component/SCART signals only)	Image Alignment	Corner Alignment	Top Left / Top Right / Bottom Left / Bottom Right / Test Pattern Enable			
Recall ISF Night or ISF Day		Midpoint Alignment	Center / Top Middle / Left Middle / Right Middle / Bottom Middle / Test Pattern Enable			
Recall/Save Custom 1 or Custom 2	Splash Configure	Owner Name				
Reset Custom 1 and Custom 2 to Factory Default		ISF Calibrated				
ISF Other						
Memory Presets	Sleep Timer	Splash Timer	5, 6, 7 ... 15 ... 59, 60			
		Splash Enable	On/Off			
		OSD Position	Hor. / Ver.	0 , 1, 2 ... 100		
Information	Signal					
	System					
	Network					
	Field Service					
	Manufacturing					

Note: Default settings appear in **bold type**.

Figure 4-1. LS-100d OSD Menu Structure

Service	Test Video	Color Bars 1	
		Color Bars 2	
		Focus	
		Grey Bars	
	Input Names	Rename/Restore	
	Display Device - Configure	Installation	Picture Orientation: Auto, Floor Front , Ceiling Front, Floor Rear or Ceiling Rear
		Diagnostics	White, Red, Green, Blue, Yellow, Cyan, Magenta
		Altitude	Auto / High
	Network	IP Configuration	DHCP (On / Off), IP Address, Subnet Mask, Default Gateway, Communication Test
		Auto Firmware Upgrade	Auto Check for New Firmware, Auto Perform Upgrade, Check for New Firmware
		E-Mail Notification	E-Mail Address, Error Notification, Error Notification to Runco, Periodic Service Notification, Lamp Life Notification, Customer Information, E-Mail Calibration Data
		Remote Network Control	On / Off
	Color Space	Auto , REC601, REC709, RGB-PC or RGB-Video	(Not available on Composite 1, Composite 2 or Composite 3 inputs)
	Triggers	1 / 2 / 3	
	Miscellaneous	Language	English , Français, Deutsch, Italiano, Español, Svenska, 简体中文 (Simplified Chinese), 繁體中文 (Traditional Chinese), Português, Русский (Russian), 日本語 (Japanese) or 한국어 (Korean)
		OSD Timer	0 (no timeout) or 5, 6, 7 ... 30 ... 60 sec.
		OSD Messages	On / Off
		Blank Screen Color	Red/Green/Blue = 0 , 1, 2, 3 ... 255
		Sidebar Color	Red/Green/Blue = 0 , 1, 2, 3 ... 255
		Film Mode (SD sources only)	On / Off
		CUE (Chroma Upsampling Error)	On / Off
	Remote Code	00, 01, 02 ... 17 ... 31	
	Sync Threshold	0, 1, 2 ... 15	(HD 1, HD 2 and Component inputs only)
	HDMI	HDMI EDID Extension	On / Off (per HDMI input)
		Audio Format	Combined / HDMI Out (To Display) / HDMI Out (Audio Only)
		CEC	On / Off
		HPD Toggle Rejection	Auto / On / Off
	Front Panel Brightness	Logo LED	0 (off), 1, 2 ... 31
		Standby LED	On / Off
		LCD	0 (off), 1, 2, 3 or 4
Auto Power Off	Enable	On / Off	
	Hours	1, 2, 3, 4, ... 8 ... 23, 24	
Standby Mode	Low Power / Fast Startup		
System Reset			

Figure 4-1. LS-100d OSD Menu Structure (continued)

The Main Menu is the starting point for accessing all DHD Controller functions.
 (You must enter a passcode to access the Calibration and Service menus.)

◀ **Main Menu**

Runco Video	
Input Source	
Aspect Ratio	
Screen	
Picture	
Input Position	
Memory Presets	
Sleep Timer	
Information	
Calibration	
Service	

From the Main Menu, select Input Source to choose a video signal source.

The active source is indicated by an arrow (➔) to its left; in this example, Composite is the active source.

◀ **Input Source**

Input Source	
➔	Composite 1
	Composite 2
	Composite 3
	Component
	HD 1
	HD 2
	SCART
	HDMI 1
	HDMI 2
	HDMI 3
	HDMI 4

To change the aspect ratio (size and shape) of the projected image, select Aspect Ratio from the Main Menu and press **ENTER**. Select the appropriate aspect ratio for your screen size and the type of program material being viewed; refer to Table 4-1.

The currently-selected aspect ratio is indicated by a "☒" to its left; in this example, 16:9 is selected.

Note that some aspect ratios are unavailable and/or not useful with certain types of source material. The optimal setting depends on a number of factors, such as:

- The aspect ratio of the source material, as broadcast or encoded on the playback medium.
- The "display type" (16:9 or 4:3) and output resolution settings at the source component. Most modern DVD/BD players and set-top boxes have such controls.
- Viewer preference (original aspect ratio with "black bars," or a full-screen presentation with some distortion or cropping).

◀ **Aspect Ratio**

Aspect Ratio	
☒	16:9
☐	4:3
☐	Letterbox
☐	VirtualWide
☐	Cinema
☐	Virtual Cinema
☐	Native



Note

The aspect ratio selection is automatically saved for each input and resolution.

Table 4-1. Aspect Ratio Settings



Aspect Ratio	Remote Control Key	Description	
16:9	16:9	 <p>16:9 Image on 16:9 Screen (Display)</p> <p>4:3 Image, stretched to fill 16:9 Screen (Display)</p>	<p>Select 16:9 to view 16:9 DVDs and HDTV programs in their native aspect ratio.</p> <p>4:3 images are stretched horizontally to fit a 16:9 screen.</p>
4:3	4:3	 <p>4:3 Image on 16:9 Screen (Display)</p>	<p>Standard 4:3 scales the input signal to fit in the center of the 16:9 screen. 4:3 is the aspect ratio used by computer monitors, standard television programming and most VHS video cassettes.</p>
Letterbox	LET BOX	 <p>4:3 Image on 16:9 Display (Letterbox aspect ratio)</p>	<p>Letterbox mode scales (zooms in on) a 4:3 image linearly (by the same amount on all sides) to fill a 16:9 display. Letterbox is best suited for viewing LaserDisc movies or non-anamorphic DVDs on a 16:9 screen.</p>
VirtualWide	V-WIDE	 <p>4:3 Image on 16:9 Screen (Display)</p> <p>4:3 Image on 16:9 Screen with VirtualWide</p> <p>4:3 Image on 2.35:1 Screen with VirtualWide</p>	<p>VirtualWide scales a 4:3 image NON-linearly (more on the sides than in the center) to fit a 16:9 screen.</p> <p>On a 2.35:1 screen, the image is centered between black bars on either side.</p>

Table 4-1. Aspect Ratio Settings (continued)

Aspect Ratio	Remote Control Key	Description	
Cinema	CINEMA	 <p>2.35:1 Image on 16:9 Screen (Cinema aspect ratio / no CineWide)</p>  <p>2.35:1 Image on 2.35:1 Screen (Cinema aspect ratio / CineWide)</p>	<p>Select Cinema to view 2.35 source material in its native aspect ratio.</p> <p>With a 16:9 screen and a standard LS-100d (without an anamorphic lens), the upper and lower portions of the screen are masked, but the geometry of the active image area is unchanged.</p> <p>With a 2.35:1 screen and an anamorphic lens, the DHD Controller scales the 2.35:1 image so that the active image area fills the 16:9 chip surface, eliminating the black bars. The secondary, anamorphic lens then restores the proper geometry to the 2.35:1 image.</p>
Virtual Cinema	V-CINE	 <p>16:9 Image on 2.35:1 Screen</p>  <p>16:9 Image on 2.35:1 Screen with Virtual Cinema</p>	<p>A 16:9 image is scaled NON-linearly (more on the sides than in the center) to fit a 2.35:1 screen.</p>
Native	NATIVE	 <p>1080i HDTV Image</p>  <p>720p HDTV Image</p>	<p>Select Native to display the source signal in its native resolution, centered in the display area with no re-sizing or overscan.</p> <p>This means, for example, that 720p HDTV programs will display with unused pixels on all sides: 320 on the left and right sides and 180 above and below.</p> <p>With SDTV and EDTV sources, the DHD Controller scales the image horizontally to achieve a 16:9 aspect ratio.</p>

Screen ➤

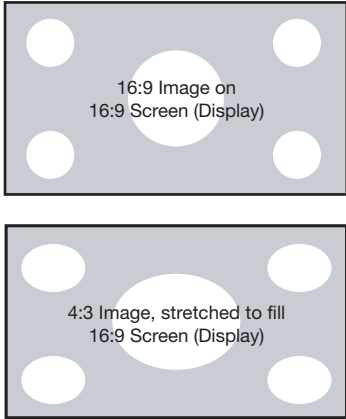
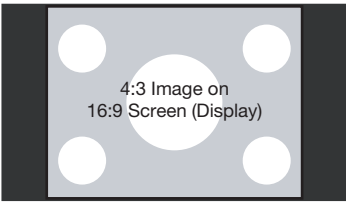
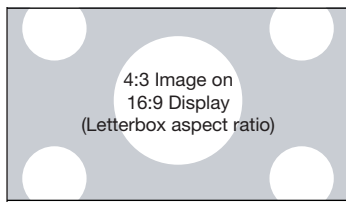
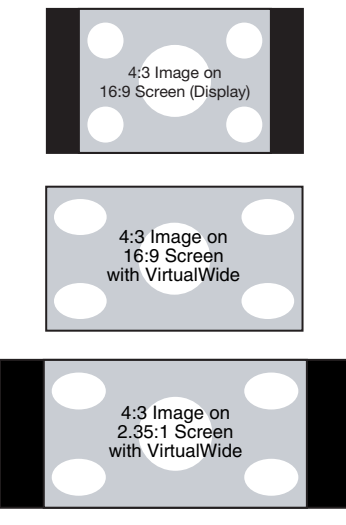
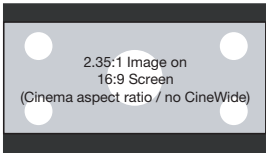
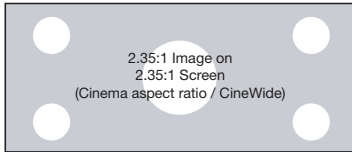
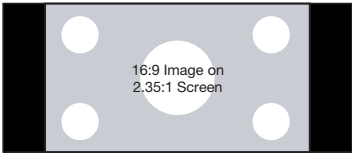
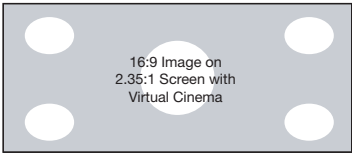
Screen
Screen 1
Screen 2

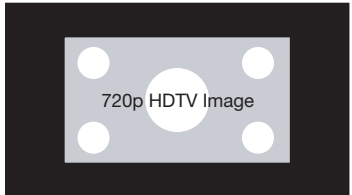
The Screen Menu allows you to recall multiple sets of stored values for certain controls (Output Shift and Image Alignment) that are saved for each aspect ratio. Such settings are also saved “per screen.” To recall the Output Shift and Image Alignment settings associated with “Screen 1” or “Screen 2,” make that selection here.

Picture ➤

Picture
Brightness
Contrast
Color
Tint
Sharpness
Noise Filter

Use the controls in the Picture Menu to calibrate each DHD Controller input to achieve optimum picture quality.

The DHD Controller has been designed to incorporate setup and calibration standards established by the Imaging Science Foundation (ISF). The ISF has developed carefully crafted, industry-recognized standards for optimal video performance and has implemented a training program for technicians and installers to use these standards to obtain optimal picture quality from Runco video display devices. Accordingly, Runco recommends that setup and calibration be performed by an ISF certified installation technician.

All signal types require separate processing. Therefore, you need to calibrate each DHD Controller input separately.



Note

*When you change a picture quality setting, save the change to a preset afterwards. Otherwise, the change will be lost when a different input is selected. (Picture quality settings are saved for each input separately.) For information about saving settings, refer to **Memory Presets** on page 46.*

Although it may be possible to obtain satisfactory picture quality using the naked eye and regular program material, Runco recommends using an external test pattern source (Ovation Multimedia, Digital Video Essentials or AVIA test DVD or equivalent) for best results.

Connect your test pattern source to the input that you are calibrating and proceed as follows. **Perform the adjustments in the order listed here.**

Brightness: On your external test pattern source, select a PLUGE pattern. (PLUGE is an acronym for “Picture Line-Up Generation Equipment.”) Figure 4-2 shows a typical PLUGE pattern.

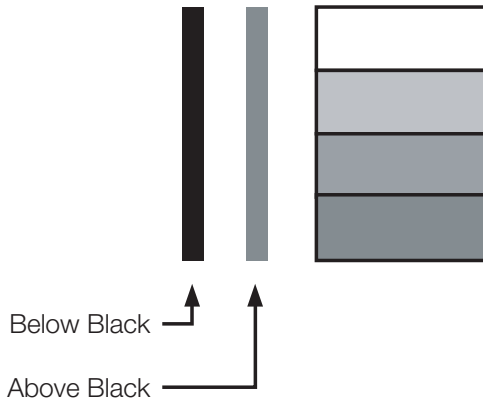

Figure 4-2. Typical PLUGE Pattern for Adjusting Brightness

PLUGE patterns vary but generally consist of some combination of black, white and gray areas against a black background. The example above includes two vertical bars and four shaded boxes.

Select Brightness from the Picture menu and press **ENTER**. Adjust the brightness so that:

- The darkest black bars disappear into the background.
- The dark gray areas are barely visible.
- The lighter gray areas are clearly visible.
- The white areas are a comfortable level of true white.
- The image contains only black, gray and white (no color).

Contrast: On your external test pattern source, select a stepped, gray-bar pattern like the one shown in Figure 4-3.

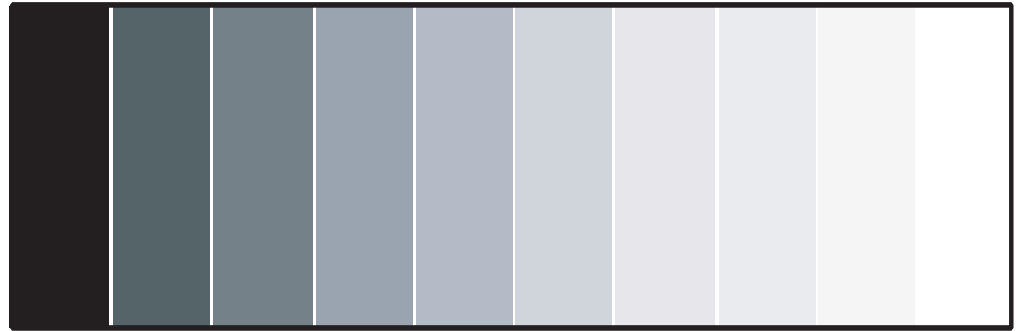

Figure 4-3. Typical Gray Bar Pattern for Adjusting Contrast

Select Contrast and press **ENTER**. Adjust the contrast to a point just below which the white rectangle starts to increase in size.



Note

Brightness and contrast controls are interactive. A change to one may require a subtle change to the other in order to achieve the optimum setting.

Color Saturation: On your external test pattern source, select a color bar pattern like the one shown in Figure 4-4.

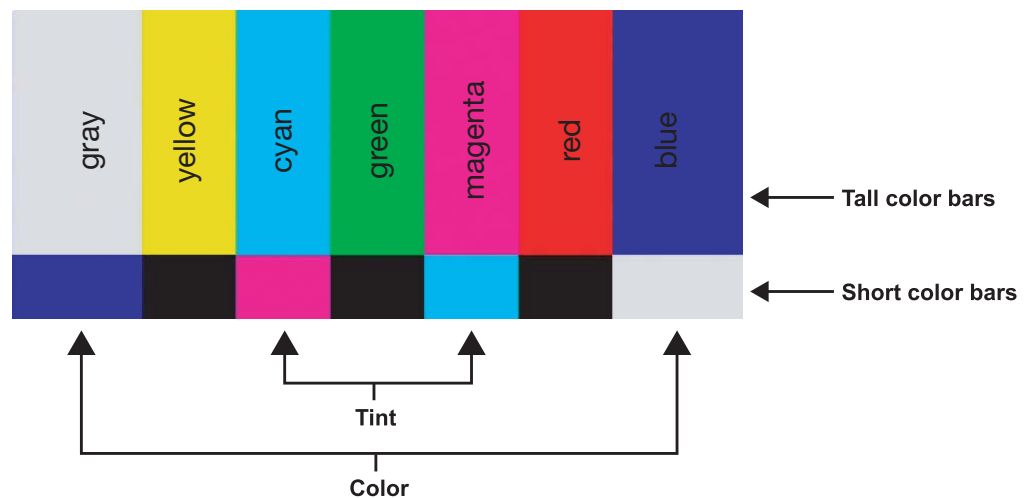
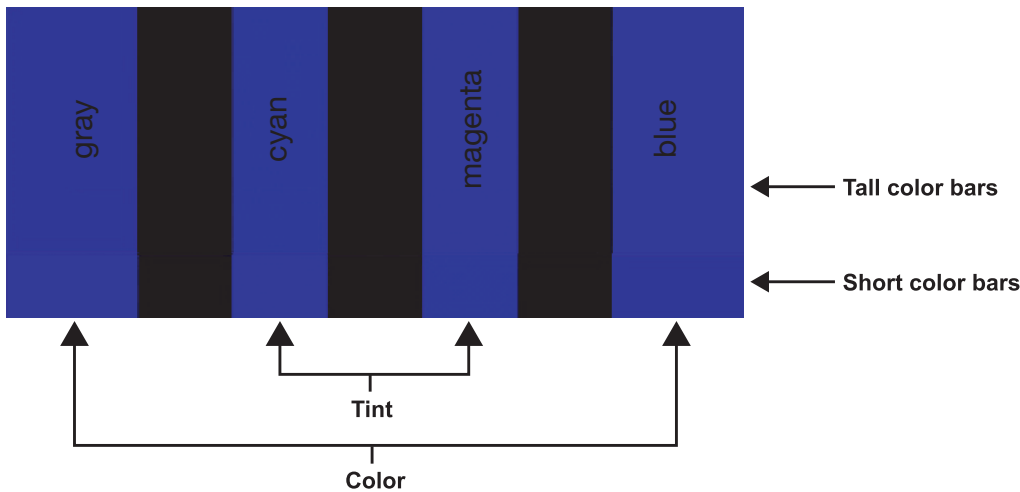

Figure 4-4. Typical Color Bar Pattern for Adjusting Color Saturation and Tint

1. Press the **MENU** button on the remote control or DHD Controller front panel.
2. Select Service from the Main Menu and press **ENTER**.
3. Enter the Service menu passcode.
4. Select Display Device from the Service menu and press **ENTER**.
5. Press **ENTER** again to select Configure.

6. Select Diagnostics and press **ENTER**.
7. Select Blue from the Diagnostics menu, then press **ENTER** to display only the blue color channel.
8. Press **EXIT** (or **MENU**) repeatedly to return to the Main Menu.
9. Select Picture from the Main Menu and press **ENTER**.
10. Select Color from the Picture menu and press **ENTER**.
11. Adjust the color saturation level until the outermost (gray and blue) color bars appear to be a single shade of blue:



Tint: Tint or “hue” is essentially the ratio of red to green in the color portion of the image. When tint is decreased, the image appears redder; when it is increased the image appears greener.

To adjust the tint, enable “blue only” display mode in the Diagnostics menu, as you would for adjusting color saturation (refer to the previous section, **Color Saturation**).

Select Tint from the Picture menu and press **ENTER**. Adjust the tint level until the cyan and magenta color bars (on either side of the green bar) appear to be a single shade of blue.



Note

Like the brightness and contrast controls, the color and tint controls are interactive. A change to one may require a subtle change to the other in order to achieve the optimum setting.

Sharpness: “Sharpness” is the amount of high-frequency detail in the image. To adjust sharpness, select Sharpness from the Picture menu and press **ENTER**. On your external test pattern source, select a pattern like the one shown in Figure 4-5. Adjust as needed, looking for white edges around the transitions from black to gray and differently-sized lines in the “sweep” patterns at the top and bottom. Lower the sharpness setting to eliminate them.

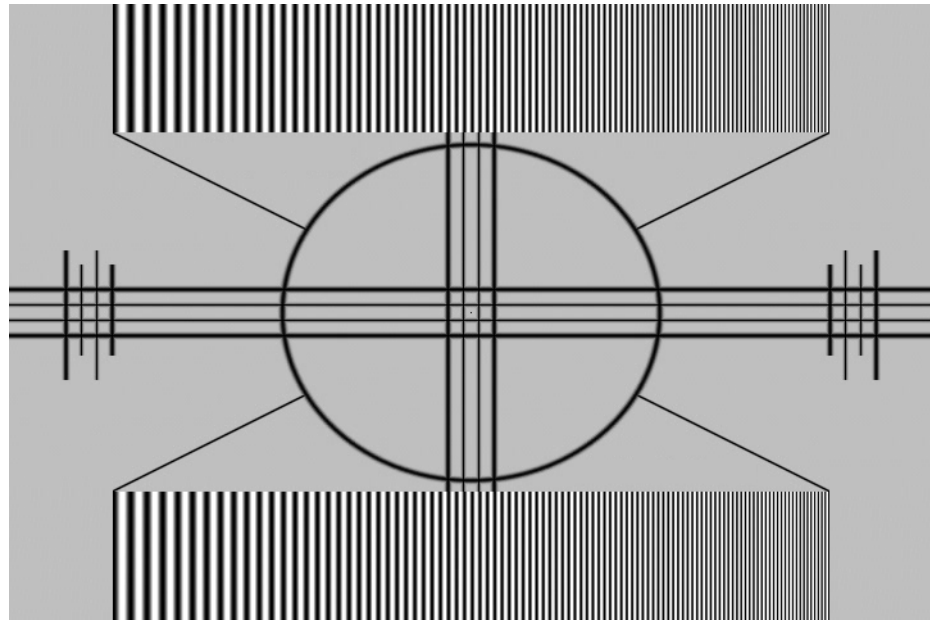

Figure 4-5. Typical Test Pattern for Adjusting Sharpness

Noise Filter: To apply noise filtering to the input signal, select Noise Filter from the Picture menu. The Noise Filter is useful for clearing up noisy images from 480i video sources.

Use the left- or right-arrow buttons to select the desired amount of noise reduction, keeping in mind that higher settings (which reduce high frequencies) may also “soften” the image.

Input Position ➤

Use the controls in the Input Position Menu to fine-tune the aspect ratio and image position for the current source.

Input Position
Left/Right
Up/Down
Width
Height
Overscan
Overscan Mode
Phase
Tracking



Note

The input position settings are automatically saved for each input and resolution.

Left/Right: Select Left/Right from the Input Position menu to shift the projected image horizontally. Press ➤ to shift the image to the right; press ◀ to shift it to the left.

Up/Down: Select Up/Down from the Input Position menu to shift the projected image vertically. Press ➤ to shift the image upward; press ◀ to shift it downward.

Width: Select Width from the Input Position menu to change the projected image width. Press ➤ to increase the width; press ◀ to decrease it.

Height: Select Height from the Input Position menu to change the projected image height. Press ► to increase the height; press ◀ to decrease it.

Overscan/Overscan Mode: Overscan pushes the outside edge of the active picture area of the video signal out beyond the edge of the display area.

Some television programs are produced based on the assumption that older television sets may not display the outer edges of the broadcast picture area. Overscan effectively trims away these inactive, outer edges and enlarges the remaining portion of the image to fill the display area.

For HDTV, DVDs and other video sources, Overscan is generally not necessary or desirable.

This control defines the amount of overscan applied to the image. The range is from 0 to 20. There are two overscan modes:

- In **Crop** mode, each increment adds a mask at the top, bottom, left and right edges of the source image equal to 0.5% of the displayed horizontal resolution (1% total). A setting of 10, for example, crops the image 5% on all sides or 10% total.
- In **Zoom** mode, each increment adds a factor to the scaling of the source image so that the vertical and horizontal resolutions are 100% plus 1% increments of the size determined by the aspect ratio function. A setting of 10, for example, zooms in on the image 5% on all sides or 10% total.

Figure 4-6 illustrates the effect of each overscan mode setting.

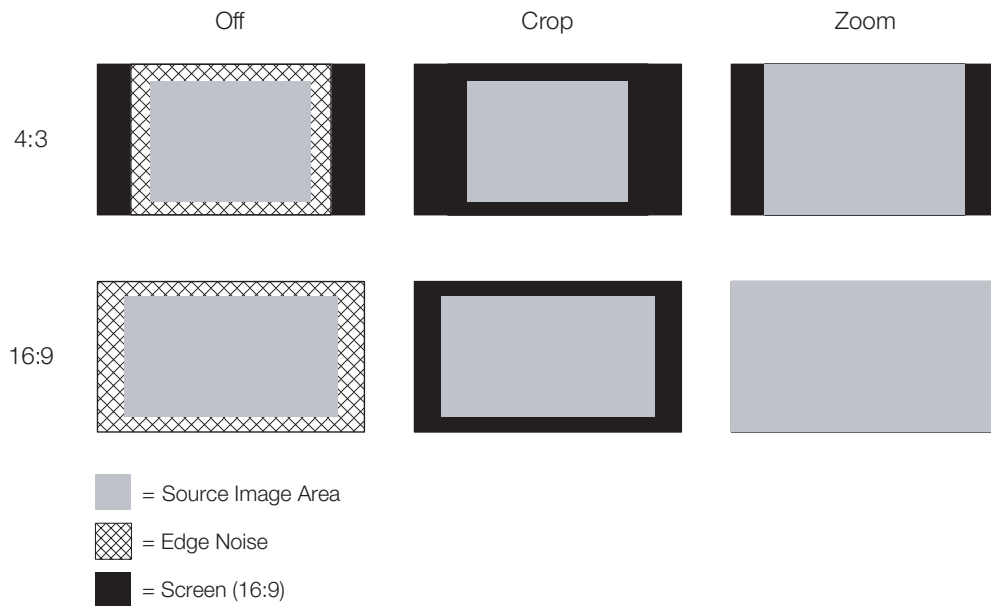

Figure 4-6. Overscan Modes

Phase (RGB, Component or SCART sources): This control adjusts the phase of the pixel sampling clock relative to the incoming signal. Adjust the phase when an RGB, Component or SCART image still shows shimmer or “noise” after Tracking has been optimized.



Tip

Adjust the Phase after adjusting Tracking (see below).

For best results, use a good test pattern such as a smooth gray consisting of a clear pattern of black and white pixels, or a similar “half on, half off” graphic image. Adjust the slider until the image stabilizes and each pixel is clearly defined. You may notice that you can stabilize the image at more than one point. Use either setting in such cases.

Tracking (RGB, Component or SCART sources): Tracking determines the frequency of the pixel sampling clock, indicated by the number of incoming pixels per line, so that all pixels generated by a particular source are sampled.

Steady flickering or several soft vertical stripes or bands across the entire image indicates poor pixel tracking. Proper pixel tracking helps ensure that the image quality is consistent across the screen, that aspect ratio is maintained and that pixel phase (see above) can be optimized.

Memory Presets ➤

Memory Presets		
➔	ISF Night	
	ISF Day	
	Custom 1	Save Reset
	Custom 2	Save Reset

For each input, the DHD Controller lets you save image quality settings as presets that you can recall at a later time. You can create up to four presets per input and display mode (resolution and frame rate).

The DHD Controller stores the following display modes in each memory preset:

- 480i
- 480p
- 576i
- 576p
- 720p/24 Hz
- 720p/25 Hz
- 720p/30 Hz
- 720p/50 Hz
- 720p/60 Hz
- 1080i/50 Hz
- 1080i/50 Hz (Australia)
- 1080i/60 Hz
- 1080p/24 Hz
- 1080p/25 Hz
- 1080p/30 Hz
- 1080p/50 Hz
- 1080p/60 Hz

Use the Memory Presets menu to recall saved image presets, or to save image settings in the “Custom 1” or “Custom 2” memory location. The currently-selected preset is indicated by a “➔” to its left; in the example shown here, ISF Night is selected.

You should save changes to any of the following settings to a preset; otherwise they will be lost when a new input source or resolution is selected:

- Brightness
- Contrast
- Color saturation
- Tint
- Sharpness
- Gamma
- Color temperature and white balance

To select a memory preset, press ▲ or ▼ to highlight it and press **ENTER**.

To save the settings for the current input and display mode to the Custom 1 or Custom 2 memory preset, select it, press ◀ or ▶ to highlight Save and press **ENTER**.



Note

*To save the settings for the current input and display mode to the ISF Night or ISF Day memory preset, select Save ISF Night or Save ISF Day from the Calibration menu (refer to **Save ISF Night/Save ISF Day** on page 53).*

To reset the Custom 1 or Custom 2 memory preset to its factory-default state, select it, press ◀ or ▶ to highlight Reset and press **ENTER**.

Select Sleep Timer from the Main Menu to turn off the LS-100d after a specified interval. Press ▲ or ▼ to select Off, 30 Minutes, 60 Minutes, 90 Minutes, 2 Hours or 4 Hours. Then, press **ENTER**.

◀ **Sleep Timer**

Sleep Timer	
→	Off
	30 Minutes
	60 Minutes
	90 Minutes
	2 Hours
	4 Hours

Information ➤

Information	
Signal	
System	
Network	
Field Service	
Manufacturing	

Signal / System: Select Information from the Main Menu, then choose either Signal or System to display information about the current input signal (resolution, frequency, type et cetera) and installed firmware versions, as well as other information that uniquely identifies your DHD Controller and display device.

Should you ever need to contact Runco Technical Support, this information will help them answer your questions or resolve product performance issues.

Signal	
Input Source	HDMI 1
Signal Format	1080p/60
Input Resolution	1920x1080
Vertical Freq	59.94 Hz
Horizontal Freq	67.500 kHz
Pixel Clock	148.500 MHz
Color Space	REC709
Sync Type	Separate
Memory Preset	ISF Night

System	
Model	DHD4
Display Name	LS-100d
Output Resolution	1920x1080
Serial Number	00000000
Boot Version	4.0
Firmware Version	4.0
Micro Version	4.0

Network	
MAC Address	1A:2B:3C:4D:5E:6F
IP Address	192.168.0.150
Subnet Mask	255.255.0.0
Default Gateway	192.168.1.1
DHCP	Enabled
Network Status	Connected

Network: Select Information from the Main Menu, then choose Network to display information about the Ethernet network connection.

To enable network communication via Ethernet, refer to **IP Configuration** on page 58.

Field Service / Manufacturing: The Field Service and Manufacturing menus are password-protected and intended for use only by Runco service personnel and factory technicians.

Use the Calibration menu to perform advanced picture quality adjustments. **This menu should be used by ISF-certified technicians only.**

◀ **Calibration**



Note

You must enter a passcode to access the Calibration menu.

To recall the ISF Night or ISF Day settings, select “ISF Night” or “ISF Day” from the Memory Presets menu (see page 46) or use the corresponding remote control buttons.

Display Color - Common Settings: Use the Display Color - Common Settings settings to adjust the color balance at the DHD Controller output. These settings are saved independently for each input and display mode.

- **Gain:** Use the Gain controls to correct color imbalances in the bright areas of the image. A good way to do this is to use a test pattern consisting mostly of solid white areas, such as an 80 IRE “window” pattern. If the white areas contain traces of red (Pr), green (Y) or blue (Pr), decrease the Gain for that color.
- **Offset:** Use the Offset controls to correct color imbalances in the dark areas of the image. A good way to do this is to use a test pattern consisting mostly of dark gray areas, such as a 30 IRE “window” pattern. If the gray areas contain traces of red (Pr), green (Y) or blue (Pr), decrease the Offset for that color.
- **Gamma:** Select Gamma from the Display Color - Common Settings menu to choose a de-gamma curve. Used correctly, the Gamma control can improve contrast while maintaining good details for blacks and whites. If excess ambient light washes out the image and it becomes difficult or impossible to see details in dark areas, lower the gamma setting to compensate. This improves contrast while maintaining good details for blacks. Conversely, if the image is washed out and unnatural, with excessive detail in black areas, increase the setting.
- **Mode:** With the LS-100d, two Gamma adjustment modes are available: Simple or Advanced. The two modes are mutually exclusive; when you select the Simple mode, the Advanced selection in the Gamma menu is grayed out. Likewise, when you select Advanced, the Simple selection is grayed out.
- **Simple:** Use the Simple Gamma control to perform gamma correction at the display according to a simple power law gamma function. The value chosen here corresponds to the power variable in this equation:

$$\text{Output} = \text{Input}^{\text{Power}}$$

The DHD Controller applies this gamma curve to all three primary color channels (red, green and blue).

- **Advanced:** To select a custom gamma curve, select Mode from the Gamma menu and set it to Advanced. Then, select Advanced from the Gamma menu to select one of up to 20 pre-programmed gamma tables. Custom gamma tables provide the ability to perform complex, non-linear gamma correction on each primary color channel independently of the others.

Calibration	
ISF Settings	
Display Color	
Input Image	
Input Color	
Save ISF Night	
Save ISF Day	
Copy/Paste	
Output Shift	
Image Alignment	
Splash Configure	
OSD Position	

- **Color Temp:** Select Color Temp from the Display Color - Common Settings menu to adjust the color temperature. Color temperature establishes the “color of gray” by adjusting the 75% white point to various color points.

What are “color points?” A “color point” is an x/y coordinate pair that defines a color’s location on the standard CIE chromaticity graph, shown in Figure 4-7. (CIE stands for “Commission Internationale de l’Éclairage” (International Commission on Illumination), the organization responsible for color measurement and management standards.)

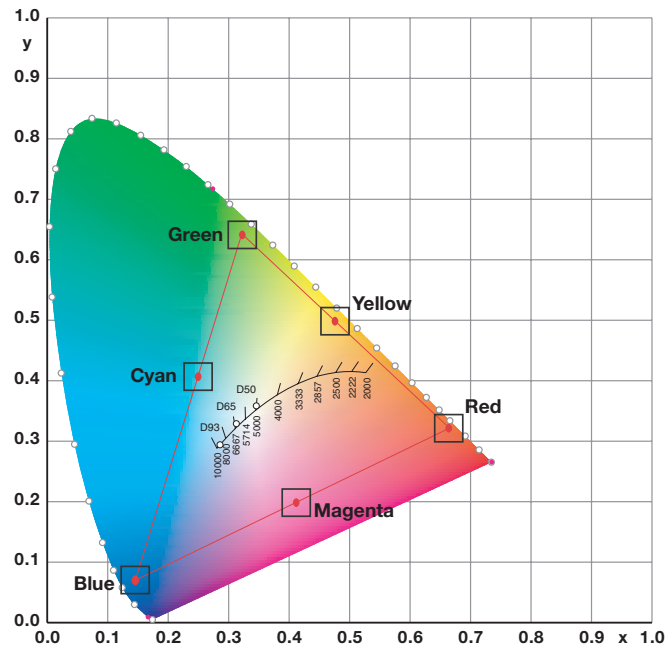

Figure 4-7. CIE 1931 Chromaticity Diagram

- **Simple:** Select Simple mode from the Color Temp menu (with the LS-100d, this is the only choice) to choose one of four color temperature presets: 5500K, 6500K, 7500K and 9300K. The default setting, 6500K, is appropriate for most situations. Higher settings produce a “bluer” picture; lower ones impart a reddish hue to the image.

Table 4-2 lists the x- and y-coordinates for each color temperature preset.

Table 4-2. Color Temperature Presets and Associated Color Points

Color Temperature Preset	Associated x/y Values	
	x	y
5500K	0.332	0.348
6500K	0.313	0.329
7500K	0.299	0.315
9300K	0.284	0.298

- **Color Gamut:** Select Color Gamut from the Display Color - Common Settings menu to select a color gamut (range) that may be different from the default color gamut.

Each setting defines the precise hue of each primary (red, green and blue) and secondary (yellow, cyan and magenta) color component used to generate the millions of colors produced in displays. Changing this setting relocates the “triangle” for possible colors (see Figure 4-7). For example, changing the x/y coordinates for red moves the color closer to either orange or violet, which in turn affects all displayed colors having a red component.



The DHD Controller uses the Color Gamut settings for all display modes on a given input.

- **Auto** automatically chooses the appropriate color gamut:
 - **SMPTE C** for NTSC, 480i and 480p sources.
 - **EBU** for PAL, SECAM, 576i and 576p sources.
 - **REC709** for all other sources.
- Select **REC709** to use the color gamut defined in ITU-R BT.709-5.
- Select **SMPTE-C** to use the color gamut defined in SMPTE 170M-1999.
- Select **EBU** to use the color gamut defined in EBU Tech. 3213-E.
- Select **Native** for Runco's recommended Personal Color Equalizer preset for typical video sources. It displays the fully saturated LED color gamut with appropriate color brightness and hue settings.
- Select **DCI** to use the color gamut defined in Digital Cinema System Specification Version 1.2.
- Select **PCE** to use the Personal Color Equalizer feature of the LS-100d. PCE lets you define a custom color gamut. Refer to the next section, **PCE**, for instructions on how to do this.

Table 4-3 lists the Color Gamut settings and associated x- and y-coordinates for each primary and secondary color component.

Table 4-3. x/y Color Gamut Values

Color Component	Color Gamut Settings and Associated x/y Values							
	REC709		SMPTE “C”		EBU		DCI	
	x	y	x	y	x	y	x	y
Red	0.640	0.330	0.635	0.340	0.640	0.330	0.680	0.320
Yellow	0.419	0.505	0.421	0.506	0.418	0.502	0.425	0.548
Green	0.300	0.600	0.305	0.595	0.290	0.600	0.265	0.690
Cyan	0.225	0.329	0.228	0.326	0.220	0.329	0.205	0.360
Blue	0.150	0.060	0.155	0.070	0.150	0.060	0.150	0.060
Magenta	0.321	0.154	0.318	0.162	0.328	0.158	0.342	0.154

- **PCE:** To use the Personal Color Equalizer to define a custom color gamut, choose the “PCE” Color Gamut setting (refer to **Color Gamut** on page 51). Then, choose PCE from the Display Color - Common Settings menu and press **ENTER**.

**Note**

The DHD Controller uses the PCE settings for all display modes on a given input.

- **Hue/Saturation/Level:** PCE provides the ability to define a custom color gamut in terms of primary (red, green and blue) and secondary (yellow, cyan and magenta) color hues, saturation and level (brightness).

Each control operates only on the color specified. Surrounding colors are linearly interpolated based on their distance from each of these colors. In the CIE 1931 Yxy coordinate system (see Figure 4-8), Hue rotates the color coordinates around the white point, Saturation adjusts the coordinate's distance from white and Level adjusts the luminance (Y) of the color relative to white.

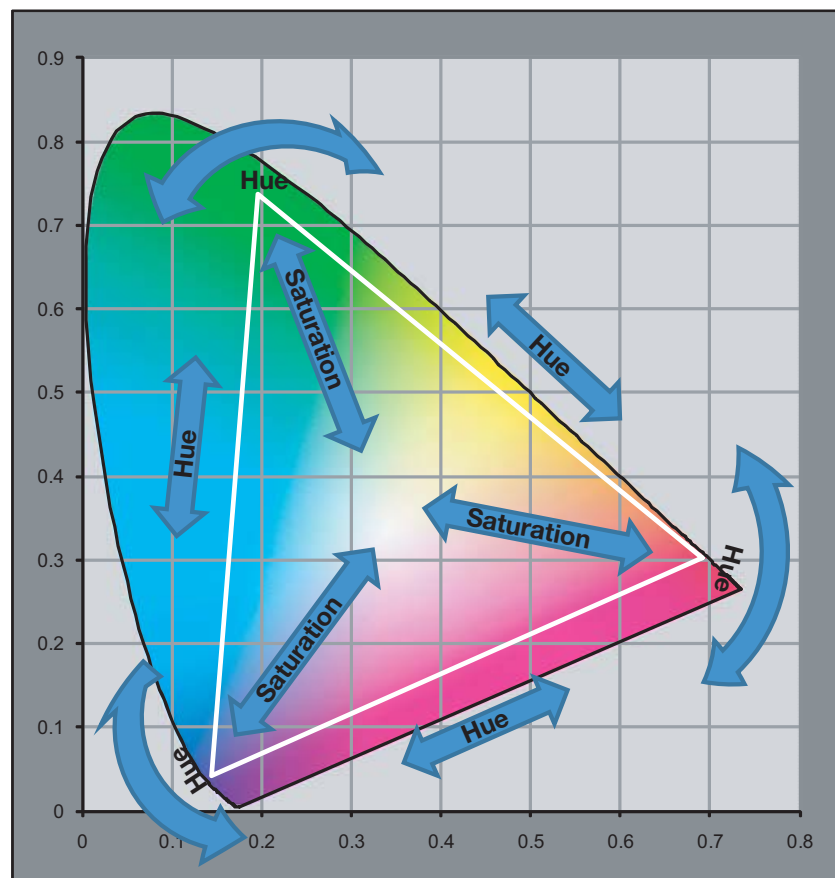

Figure 4-8. Effect of PCE Hue and Saturation Controls

- **White Balance:** To precisely adjust the white point associated with the custom color gamut, choose White Balance from the PCE sub-menu. These controls operate identically to the Gain controls in the Display Color - Common Settings menu (described on page 49).

Display Color - Projector Settings: These settings are also saved independently for each input and display mode.

- **SatCo (BrilliantColor™):** Select SatCo (BrilliantColor™) from the Display Color - Projector Settings menu to enable (**Low/High**) or disable (**Off**) BrilliantColor processing, which improves brightness in grays and secondary colors. The default is **Off**.

Input Image: The Input Image controls are functionally similar to those in the Picture menu (refer to page 40), but are accessible only by entering the Calibration menu passcode.



Note

The Input Image settings establish the “zero point” for the Picture menu settings, whose values represent offsets from the Input Image settings. For example, if you set Brightness to 10 in this menu, setting Brightness to 10 in the Picture menu results in an actual setting value of 20 (10+10).

Input Color: The Input Color controls are similar to those in the Display Color menu (see above), but adjust the color balance of the incoming signal. These settings are also saved independently for each input and display mode.

- **Gain/Offset (HD1, HD2 and Component/SCART inputs only):** These controls operate similarly to those in the **Display Color - Common Settings** menu (described on page 49), but affect the Y, Pb and Pr signal components rather than the red, green and blue channels.
- **Chroma Delay:** use the Chroma Delay control to correct a mis-aligned image from a composite video source. Chroma delay in an image causes color shifts to occur to the left of the vertical edge transitions, producing artificial shadows or a “halo” effect. If necessary, adjust this setting to eliminate them.
- **Noise Filter:** To apply noise filtering to the input signal, select Noise Filter from the Input Color menu. The Noise Filter is useful for clearing up noisy images from 480i video sources.

Use the left- or right-arrow buttons to select the desired amount of noise reduction, keeping in mind that higher settings (which reduce high frequencies) may also “soften” the image.

Save ISF Night/Save ISF Day: Whenever you make a change to the ISF settings, you should always save it. Select Save ISF Night or Save ISF Day from the Calibration menu to do this.

Copy/Paste	
Memory Preset	
Aspect Ratio	

Memory Preset	
Copy Settings	
Paste Settings	
Copied From:	
Input Source	HDMI 1
Signal Format	1080p/60
Memory Preset	ISF Night

Copy/Paste - Memory Preset: You can copy and paste settings from one memory preset to another. This gives you a convenient starting point for creating a new preset based on an existing one, to make the calibration process less time-consuming.

For example, you can use the Copy/Paste Memory Preset feature to:

- Apply settings from HDMI 1 to HDMI 2, or from HD1 to HD2.
- Calibrate an input for 720p source signals, then use those settings for 1080i sources.
- Duplicate ISF Night settings for a given source and signal format and save them in the Custom 1 memory preset.

To use this feature, select Copy/Paste from the Calibration menu, then select Memory Preset.

- **Memory Preset - Copy Settings:** Select Copy Settings from the Copy/Paste Memory Preset menu to place the settings for the current input source, signal format (resolution and frame rate) and memory preset onto a “clipboard,” which is a temporary memory location. When you do, the message “Settings Copied” briefly appears on-screen. The Copy/Paste menu then re-appears, indicating the source of the copied settings.



Note

Copied settings are not retained after a power cycle.

- **Memory Preset - Paste Settings:** To apply the settings on the clipboard to a different input source, signal format and/or memory preset, do **any or all** of the following:

- Switch to another input (for example, from HD1 to HD2).
- Change the output signal format at the source (for example, from 720p/60 to 1080i/60).
- Switch to another Memory Preset (for example, from ISF Night to Custom 1).

Then, select Paste Settings from the Copy/Paste Memory Preset menu. **If you want to keep these new settings, you must save them!** (Refer to **Save ISF Night/Save ISF Day** on page 53 or **Memory Presets** on page 46.)

Copy/Paste - Aspect Ratio: You can also copy and paste certain settings, such as those for Output Shift and Image Alignment (refer to page 55) from one aspect ratio or “screen” (refer to **Screen** on page 40) to another.

To do this, select Copy/Paste from the Calibration menu, then select Aspect Ratio.

- **Aspect Ratio - Copy Settings:** Select Copy Settings from the Copy/Paste Aspect Ratio menu to place the Output Shift and Image Alignment settings for the current aspect ratio onto a “clipboard,” which is a temporary memory location. When you do, the message “Settings Copied” briefly appears on-screen. The Copy/Paste menu then re-appears, indicating the source of the copied settings.



Note

Copied settings are not retained after a power cycle.

Copy/Paste	
Memory Preset	
Aspect Ratio	

Aspect Ratio	
Copy Settings	
Paste Settings	
Copied From:	
Aspect Ratio	16:9
Screen	Screen 1

- **Aspect Ratio - Paste Settings:** To apply the Output Shift and Image Alignment settings on the clipboard to a different aspect ratio and/or screen, do **either** of the following:
 - Switch to another aspect ratio (for example, from 16:9 to Cinema).
 - Switch from Screen 1 to Screen 2 or vice versa.

Then, select Paste Settings from the Copy/Paste Aspect Ratio menu. The new settings are saved automatically.

Output Shift: The Left/Right, Up/Down, Width and Height controls in the Output Shift menu are similar to those in the Input Position menu, except that they change the characteristics of the output signal. These settings are saved independently **for each aspect ratio and screen selection** (refer to **Screen** on page 40).

- **Screen Masking:** This control adjusts the amount of cropping on each edge of the output image. This differs from the regular Overscan control in two ways:
 - It allows separate adjustments on each edge; and
 - It is saved per aspect ratio, per screen (as opposed to per connector, per mode).

This is useful for installations where the aspect ratio of the screen doesn't exactly match the aspect ratio of the display.

Image Alignment: Use the controls in the Image Alignment menu to ensure proper image geometry; that is, a perfectly rectangular projected image with no keystone or pincushion. For detailed instructions, refer to **Adjusting the Image Geometry** on page 32.

Splash Configure: Use the Splash Configure menu to control the appearance and behavior of the "splash" screen that appears on the display upon power-up.

- **Owner Name/ISF Calibrated/ISF Other:** You can have the LS-100d display the owner's name, your name, the phrase "ISF Calibrated" and/or any other string, up to 30 characters in length.

Use the up or down cursor button to select a character. Use the right and left cursor buttons to change the cursor position. Press **MENU** when you have finished entering text.

- **Splash Timer:** When you turn on the LS-100d, it projects a welcome screen with the Runco and ISF logos, along with the personalized information you enter as described above. Select Splash Timer from the Splash Configure menu to set the amount of time for which this screen appears. The range is from 5 to 60 seconds, in one-second increments. Press ◀ or ▶ to set the timer, then press **MENU**.
- **Splash Enable:** When you have finished customizing the splash screen, select Splash Enable from the Splash Configure menu. Then, select On and press **ENTER**.

OSD Position: To adjust the position of the OSD, select OSD Position from the Calibration menu and press **ENTER**.

Press ▲ or ▼ to select "Hor." or "Ver." Then, press ◀ or ▶ to change the position.

Service ➤ Use the Service menu to access advanced projector configuration settings. **This menu should be used by ISF-certified technicians only.**

Service
Test Video
Input Names
Display Device
Network
Color Space
Triggers
Miscellaneous
Sync Threshold
HDMI
Front Panel Brightness
Auto Power Off
Standby Mode
System Reset



Note

You must enter a passcode to access the Service menu.

Test Video: Select Test Video from the Service Menu to access the internal test patterns on the DHD Controller. Table 4-4 lists the available test patterns and describes their suggested usage.

Table 4-4. Test Patterns and Their Suggested Usage

Pattern	Suggested Usage
<p>Color Bars 1</p>	Use this pattern when making color saturation and tint adjustments.
<p>Color Bars 2</p>	Use this pattern when making color saturation and tint adjustments.
<p>Focus</p>	Use this pattern when adjusting the focus.
<p>Grey Bars</p>	Use this pattern when making brightness, contrast or white balance (gain/offset) adjustments.

Press **MENU** to exit test pattern mode.

Input Names: You can give each DHD Controller input a descriptive name. For example, you may want to change the default input name to the type of source component connected to it: “VCR,” “DVD,” “Laptop” et cetera. Input names can be up to 12 characters long.

To edit an input name, select Input Names from the Service menu. Press ▲ or ▼ to select an input and press **ENTER**. Use the ▲ or ▼ buttons to change a character; press ◀ or ▶ to select a character to change. When you have finished editing the input name, press **ENTER** or **MENU**.

To restore the default input name, press ▼ repeatedly to highlight that input name in the “Restore” column. Then, press **ENTER**.

Input Names	
	Restore
Composite 1	Composite 1
Composite 2	Composite 2
Composite 3	Composite 3
Component	Component
HD 1	HD 1
HD 2	HD 2
SCART	SCART
HDMI 1	HDMI 1
HDMI 2	HDMI 2
HDMI 3	HDMI 3
HDMI 4	HDMI 4

Display Device - Configure: The options in the Display Device - Configure menu allow you to change the picture orientation or access other, display-device specific functions.

- **Installation – Orientation:** Select Installation from the Display Device - Configure menu, then select Orientation to change the picture orientation to suit the method of installation (Floor Front, Floor Rear, Ceiling Front or Ceiling Rear). Or, for front-projection installations, use the **Auto** setting to have the projector automatically determine the orientation (floor or ceiling) using an internal sensor.
- **Diagnostics:** Select Diagnostics from the Display Device - Configure menu, then select Red, Green, Blue, Yellow, Cyan or Magenta to display only that color channel (simulating a filter of that color). This can be useful for calibration or measurement purposes.

To restore the normal picture (all colors), select White.

- **Altitude:** Select Altitude from the Display Device - Configure menu to control the operation of the projector’s cooling fan.

In most cases, the default setting (**Auto**) will maintain the correct operating temperature. If the projector frequently turns off due to overheating, or in certain high-altitude operating environments, you may need to change this setting to **High**.

Network: The options in the Network menu allow you to configure the network communication features.

- **IP Configuration:** Select IP Configuration from the Network menu to either set the IP address, subnet mask and default gateway of the DHD Controller manually or obtain these settings automatically, from a DHCP (Dynamic Host Configuration Protocol) server. (Most broadband routers and gateways support DHCP.) You can also test the network connection from this menu.
- **DHCP:** To enable the DHCP client in the DHD Controller, select DHCP from the IP Configuration menu and set it to **On**. With this setting, the DHD Controller's IP address, subnet mask and default gateway are assigned by the local DHCP server.

To manually configure these values, set DHCP to **Off**.



Note

The IP Address, Subnet Mask and Default Gateway items in the IP Configuration menu are disabled (grayed out) when DHCP is enabled.

- **IP Address:** Select IP Address from the IP Configuration menu to manually configure the IP Address of the DHD Controller, as follows:
 1. Press ▲ or ▼ to select the first, second, third or fourth byte of the address.
 2. Press ► or ◀ to set the value of that byte. The range is from 0 to 255 inclusive.
 3. Repeat Steps 1 and 2 for all four bytes of the address.
 4. Press **MENU** when you have finished setting the address.
- **Subnet Mask:** Select Subnet Mask from the IP Configuration menu to manually configure the IP subnet mask. The procedure is similar to that for setting the IP address.
- **Default Gateway:** Select Default Gateway from the IP Configuration menu to manually configure the default IP gateway. The procedure is similar to that for setting the IP address.
- **Communication Test:** Select Communication Test from the IP Configuration menu to verify proper operation of the network communication link.

To start the test, select Start Test from the Communication Test menu. The DHD Controller displays the message "Performing Communication Test." When the test completes, the DHD Controller displays either "Failed" (along with the error that occurred) or "Succeeded."

- **Auto Firmware Upgrade:** Select Auto Firmware Upgrade from the Network menu to enable automatic detection of a newer version of the DHD Controller firmware. If one is found, you can configure the DHD Controller to install it automatically. These features make it easier to keep your DHD Controller firmware up-to-date.
- **Auto Check For New Firmware:** To have the DHD Controller automatically check for firmware updates at periodic intervals, select Auto Check for New Firmware from the Auto Firmware Upgrade menu and set it to **On**. If you prefer to do this manually, set it to **Off** and use the Check For New Firmware sub-menu (described below).
- **Auto Perform Upgrade:** If the "Auto Check For New Firmware" process determines that a newer firmware version than the one currently installed is available, you can have the DHD Controller automatically download and install it. To do this, select Auto Perform Upgrade from the Auto Firmware Upgrade menu and set it to **On**. The upgrade will occur the next time the DHD Controller is "power-cycled" (powered off, then on again).

If you prefer to do this manually, set it to **Off**. The DHD Controller will ask if you want to perform the upgrade the next time it is power-cycled.

- **Check For New Firmware:** To have the DHD Controller check for new firmware on demand (and perform an upgrade if it finds a new version), select Check For New Firmware from the Auto Firmware Upgrade menu. If the DHD Controller finds a new firmware version, select **Yes** to perform the upgrade or **No** to return to the previous menu.
- **E-Mail Notification:** Select E-Mail Notification from the Network menu to specify when and to whom the DHD Controller sends error and service notification messages via e-mail.

The notification messages are in the following format:

```
To: [E-Mail Address; see below]
From: do-not-reply@runco.com
Subject: [Type of notification] from Runco DHD4
Body:
```

This is an automated message sent from the Runco DHD4:

```
Notification: [One of the following:
               "DHD Error" / "Display Error"
               "Periodic Service Notification"
               "Lamp Life Notification" / "Calibration Data"]
```

```
Detailed Description: [ If a DHD Error, one of the following:
                       "Fan Failure 1" / "Fan Failure 2"
                       "Overtemp 1" / "Overtemp 2"
                       "Initialization Failure"
```

```
If a Display Error, a device-specific
error message such as "Lamp Door Open"
```

```
If a Periodic Service Notification, the elapsed
time since the last notification
```

```
If a Lamp Life Notification, the number of hours
the lamp has been in service
```

```
If a Calibration Data message,
"See Attached File" ]
```

```
Serial Number: [DHD Controller serial number]
Customer Information: [From "Customer Information" sub-menu;
                     see below]
```

Best Regards,

Runco International, LLC
1195 NW Compton Drive
Beaverton, OR 97006
1-800-237-8262

- **E-Mail Address:** To specify the destination e-mail address for error and service notifications, select E-Mail Address from the E-Mail Notification menu. The procedure is similar to that for setting the IP address (refer to **IP Configuration** on page 58). Enter up to 45 alphanumeric characters.

- **Error Notification:** To have the DHD Controller send a message to the destination e-mail address when a “DHD Error” or “Display Error” occurs, select Error Notification from the E-Mail Notification menu and set it to **On**.
- **Error Notification to Runco:** To have the DHD Controller send an e-mail message to Runco Customer Support when a “DHD Error” or “Display Error” occurs, select Error Notification to Runco from the E-Mail Notification menu and set it to **On**.
- **Periodic Service Notification:** You can have the the DHD Controller send periodic reminders via e-mail to perform regular maintenance tasks. To do this:
 1. Select Periodic Service Notification from the E-Mail Notification menu.
 2. Highlight **Enable** and press **ENTER**.
 3. Highlight **On** and press **ENTER**.
 4. Press **MENU**.
 5. Highlight **Timer** and press **ENTER**.
 6. Press **▶** or **◀** to set the notification interval in months. The range is from 1 to 255 inclusive; the default is 12 months.
 7. Press **MENU**.
- **Lamp Life Notification:** To have the DHD Controller send a message to the destination e-mail address when the lamp hour counter reaches a certain threshold, select Lamp Life Notification from the E-Mail Notification menu. Then:
 1. Highlight **Enable** and press **ENTER**.
 2. Highlight **On** and press **ENTER**.
 3. Press **MENU**.
 4. Highlight **Lamp Hours** and press **ENTER**.
 5. Press **▶** or **◀** to set the notification threshold in hours. The range is from 100 to 10,000 hours; the default is 1,000 hours.
 6. Press **MENU**.
- **Customer Information:** Select Customer Information from the E-Mail Notification menu to supply this information to the DHD Controller, which includes it in all e-mail notification messages. Six lines (up to 30 characters per line) of text are provided; use them however you wish.
 1. Press **▲** or **▼** repeatedly to select a line of text to edit.
 2. Press **ENTER**.
 3. Press **▲** or **▼** repeatedly to set the highlighted character.
 4. Press **▶** (or **◀**) to select the next (or previous) character. Use the **▲** and **▼** buttons to change it.
 5. Press **ENTER** when you have finished editing that line of text.
 6. Repeat Steps 1 through 5 for each line of text you want to edit.
 7. Press **MENU** when you have finished entering customer information.
- **E-Mail Calibration Data:** To have the DHD Controller collect all calibration data, attach it to a message and send it to the destination e-mail address, select E-Mail Calibration Data from the E-Mail Notification menu. To confirm this action, select **Yes** and press **ENTER**.

To cancel and return to the previous menu, select **No**.

- **Remote Network Control:** Select Remote Network Control from the Network menu to enable or disable control of the DHD Controller via an IP connection (typically using a web browser). Set it to **On** to allow all incoming remote network connectivity. Set it to **Off** to disable any incoming network communication that was not initiated by the DHD Controller.

**Note**

This setting has no effect on the E-Mail Notification or Auto Firmware Upgrade functions.

Color Space: Select Color Space from the Service menu to choose the color space of the source signal for HDMI, RGB, and component connections.

- The default setting, **Auto**, functions as follows:
 - **HDMI:** If the Auxiliary Video Information (AVI) infoframe contains color space and/or range data, the DHD Controller uses that information. Otherwise, for RGB sources, the DHD Controller uses the **RGB-Video** color space. For component SDTV and EDTV resolutions, **REC601** is used. For other component video resolutions, **REC709** is used.
 - **RGB:** If Hsync or Vsync signals are present, the DHD Controller uses the **RGB-PC** color space. Otherwise, **REC601** is used for SDTV and EDTV sources, and **REC709** for all other sources.
 - **Component:** For SDTV and EDTV resolutions, the DHD Controller uses the **REC601** color space. For all other resolutions, REC709 is used.

In most cases, the **Auto** setting determines the correct color space to use. If it does not, you can force the DHD Controller to use a specific color space. Choose one of the following:

- **REC709** sets the color space matrix to that defined in ITU-R BT.709.
- **REC601** sets the color space matrix to that defined in ITU-R BT.601.
- **RGB-PC** uses RGB color space and sets black at 0,0,0 RGB and white at 255,255,255 RGB, assuming an 8-bit image.
- **RGB-Video** uses RGB color space and sets black at 16,16,16 RGB and white at 235,235,235, assuming an 8-bit image, to correspond to the luminance values defined in digital component standards.

Triggers: Select Triggers from the Service menu to configure the 12-volt trigger outputs. You can assign one or more trigger outputs to each aspect ratio. Those triggers are then activated by selecting that aspect ratio.

If your LS-100d is equipped with an anamorphic lens, assign at least one trigger output (the same one to which the lens motor is connected) to the Cinema and Virtual Cinema aspect ratios.

Miscellaneous: Select Miscellaneous from the Service menu to set the following options:

- **Language:** Select Language from the Miscellaneous menu and press the up- or down-arrows to select the OSD Language (English, Français, Deutsch, Italiano, Español, Svenska, 简体中文 (Simplified Chinese), 繁體中文 (Traditional Chinese), Português, Русский (Russian), 日本語 (Japanese) or 한국어 (Korean)).
- **OSD Timer:** Select OSD Timer from the Miscellaneous menu to set the OSD Timer, which controls how long the menus remain on-screen after selecting them. Select from 5 to 60 seconds, in one-second increments. Or, set the timer to 0 (disabled) if you want the menus to remain on-screen indefinitely.

- **OSD Messages:** When you select a new aspect ratio, input source or memory preset, the DHD Controller briefly displays an on-screen message confirming your new selection. To prevent the display of these messages, select OSD Messages from the Miscellaneous menu to and set it to **Off**.
- **Blank Screen Color:** Select Blank Screen Color from the Miscellaneous menu to select the color that appears when no incoming signal is present. The range is from 0 to 255 inclusive for each color component (red, green and blue).
- **Sidebar Color:** Select Sidebar Color from the Miscellaneous menu to change the color of the inactive image area. The range is from 0 to 255 inclusive for each color component (red, green and blue). The inactive image area is on either side of the active image area when using the 4:3 aspect ratio.
- **Film Mode:** Use Film Mode to smooth out moving images from interlaced, standard-definition (SD) sources. In most cases, the DHD Controller detects the proper “pull-down” rate and vertical frequency. However, if your source is jittery and/or tearing you may want to enable Film Mode to ensure stable processing for that source.
- **CUE (Chroma Upsampling Error) Correction:** Some DVD players use MPEG decoders that do not correctly “upsample” the 4:2:0 format chroma information on the DVD to the 4:2:2 or 4:4:4 format required by the video encoder of the display device.

This so-called “chroma bug” sometimes causes streaky or spiky horizontal lines running through the chroma channel. It is most noticeable in static, interlaced scenes and on diagonal edges (especially red ones). Set CUE to **On** to correct this issue.

- **Remote Code:** Select Remote Code from the Miscellaneous menu to set the infrared (IR) code set to which the DHD Controller will respond. By default, it is set to 17. You can change this setting if either:
 - Another device in the theater (a DVD player, for example) is responding to commands from the DHD Controller remote control (Figure 2-5) in ways that are unpredictable or undesirable.
 - You have multiple DHD Controllers and want to control them independently, as opposed to broadcasting commands from a single remote to all of them. In this scenario, you can use multiple remotes programmed to use different IR codes. Or, you can use a single remote and change the IR code as needed to address a specific DHD Controller.



Tip

Use the DHD Controller front-panel keypad to change the IR code to which the controller will respond. Then, change the code sent by the remote to match as described below.

When you change a remote code on the DHD Controller, you must re-program the DHD Controller remote control to send that same code. To do this:

1. Press and hold the **LIGHT** button on the remote control for approximately three seconds, or until the LED on the remote lights solid red.
2. Enter a new two-digit code between 00 and 31 inclusive. Include a leading zero for single-digit codes; for example, enter 9 as “09.”
3. The LED turns off to confirm the code change. If you enter an invalid code, the LED flashes for three or four seconds. Try again, entering a valid code.

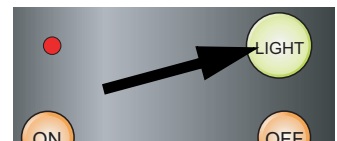

Sync Threshold: Select Sync Threshold to adjust the threshold at which negative pulses on the component video green/luma channel are interpreted to be sync pulses.

Sync Threshold adjustment is occasionally necessary when a DVD player or HDTV source signal drops “below black” (for example, during scenes with explosions or when subtitles are present) and causes the projector to temporarily lose sync. If the sync level from the source is persistently too low, the display device won’t sync with the source at all.

The range is from 0 (approximately 60 millivolts (mV)) to 15 (approximately 300 mV).

HDMI: Select HDMI from the Service menu to set the following options affecting communication between HDMI sources, the DHD Controller and the LS-100d.

- **HDMI EDID Extension:** Extended display identification data (EDID) is a data structure provided by a display device to describe its capabilities to a graphics card. It is what enables a modern personal computer to know what kind of monitor is connected.

Some modern display devices provide more information via EDID than others, in the form of “extensions.” Some computer graphics cards do recognize or properly interpret this extended EDID information.

Select HDMI EDID Extension from the HDMI menu to specify whether or not the EDID extensions from the display device are passed through to the sources connected to the HDMI 1, HDMI 2, HDMI 3 or HDMI 4 inputs. By default, the extensions are on. Change these settings only if HDMI EDID incompatibility issues arise.

- **Audio Format:** Select Audio Format from the HDMI menu to choose an option for routing the audio signal from an HDMI source. With the LS-100d, the recommended setting is **HDMI Out (Audio Only)**. (This is the default setting.)
- **CEC:** This control chooses whether or not the DHD Controller responds to HDMI CEC control messages from a disc player, set-top box or other HDMI source. It also enables or disables CEC communication between the DHD Controller and projector.

The default (and recommended) setting is **On**. For more information about CEC, refer to **Using HDMI CEC Messages** on page 87.



Note

1. Setting **CEC** to **Off** prevents communication between the DHD Controller and projector, and should be done only for troubleshooting purposes.

2. The DHD Controller does not transmit HDMI CEC control messages from the “HDMI Audio Out” connector.

- **HPD Toggle Rejection:** Select HPD Toggle Rejection from the HDMI menu to specify whether or not the DHD Controller ignores extraneous Hot Plug Detect (HPD) signal state changes from a downstream HDMI device (third-party display or audio/video receiver).

The default setting, **Auto**, disables HPD toggle rejection on the LS-100d. Use the other settings to troubleshoot compatibility issues or reduce the amount of time needed to lock to an incoming signal.

Front Panel Brightness: Select Front Panel Brightness from the Service menu to adjust the brightness of the front-panel LED and LCD status indicators.

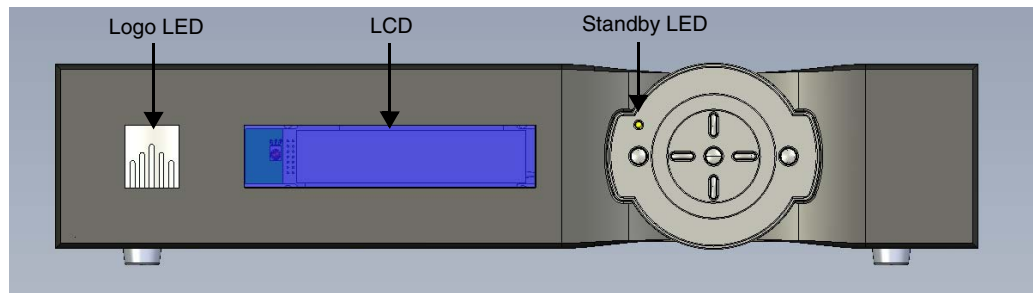

- **Logo LED:** Select Logo LED from the Front Panel Brightness menu to adjust the brightness of the large, illuminated logo on the left side of the display. The range is from 0 (off) to 31.



Note

During a firmware upgrade, this LED lights at full brightness regardless of the Logo LED setting.

- **Standby LED:** Select Standby LED from the Front Panel Brightness menu to change the behavior of the front-panel STANDBY indicator LED. When set to ON, the LED lights amber when the system is in standby mode; otherwise, it is off. When set to OFF, the LED is always off.



Note

During a firmware upgrade, this LED lights at full brightness regardless of the Standby LED setting.

- **LCD:** Select LCD from the Front Panel Brightness menu to adjust the brightness of the front-panel LCD. The range is from 0 (off) to 4.

Auto Power Off: Select Auto Power Off from the Service menu to have the LS-100d turn itself off after a period of inactivity (no source signal present).

- **Enable:** By default, Auto Power Off is disabled. To enable it, select Enable from the Auto Power Off sub-menu and set it to On.
- **Hours:** The default time-out period is eight (8) hours; the range is from 1 to 24 hours.

Standby Mode: Select Standby Mode from the Service menu to control the DHD Controller's power management feature.

- Choose **Low Power** (the default setting) to have the DHD Controller shut down completely when it is turned off. This conserves power but increases the amount of time required by the DHD Controller to start up when it is turned on.
- **Fast Startup** is a "quick-start" mode that keeps the DHD Controller running when it is turned off, even though it appears to be in standby mode. This results in much quicker startup times but consumes more power.

System Reset: To reset ALL controller settings (including image settings) back to their factory defaults, choose System Reset from the Service menu.

A confirmation message appears. Select Yes to continue with the reset or select No to cancel.



Caution

This action is not undoable. Proceed with caution! Before you perform a System Reset, save your "Custom" Memory Presets (page 46) and ISF Day/Night Memory Presets (page 53).

Notes:

5. Maintenance and Troubleshooting

The LS-100d Ultra Short-Throw LED Home Theater Projector and DHD Controller does not require any routine maintenance. There are no user-serviceable or -replaceable parts. Unless you are a qualified, factory-trained Runco technician, **do not attempt to repair or replace any system component yourself.** You will void the product warranty if you do so.

◀ Maintenance

Table 5-1 provides some general guidelines for troubleshooting problems you may encounter with the LS-100d Ultra Short-Throw LED Home Theater Projector and DHD Controller. If the suggested solutions fail to resolve the problem or if you encounter an issue not described here, please contact your Runco dealer or Runco Technical Support.

◀ Troubleshooting

Table 5-1. Troubleshooting Chart

Symptom	Possible Cause(s)	Solution
The projector does not turn on.	<ul style="list-style-type: none"> The projector is not plugged in or the AC outlet is not active. The DHD Controller is not plugged in or the AC outlet is not active. The remote control batteries have run out. 	<ul style="list-style-type: none"> Ensure that the projector is plugged in and that the AC outlet is active. Ensure that the DHD Controller is plugged in and that the AC outlet is active. Replace the batteries.
The display and DHD Controller both turn on, but there is no picture and on-screen menus do not appear.	<ul style="list-style-type: none"> Faulty or incorrect video connection from the DHD Controller to the display. 	<ul style="list-style-type: none"> Ensure that the HDMI output from the DHD Controller is properly connected to the display (see Figure 3-1). Try a known-good and/or shorter HDMI cable.
The display is on and menus appear, but there is no picture.	<ul style="list-style-type: none"> Incorrect source selection. Source component is not turned on. Source component is connected incorrectly or not at all. 	<ul style="list-style-type: none"> Select the correct source. Turn on the source component. Check connections from the source component to the DHD Controller.
Image is too bright and/or lacks definition in the bright areas of the image.	<ul style="list-style-type: none"> Contrast is set too high. 	<ul style="list-style-type: none"> Lower the contrast setting.
Image appears "washed out" and/or dark areas appear too bright.	<ul style="list-style-type: none"> Brightness is set too high. 	<ul style="list-style-type: none"> Lower the brightness setting.
Colors in the image are swapped; for example, reds appear blue or vice versa.	<ul style="list-style-type: none"> The Red/Pr, Green/Y or Blue/Pb outputs from the source are connected to the wrong inputs on the DHD Controller. 	<ul style="list-style-type: none"> Ensure that the source outputs are connected to the correct DHD Controller input.

Table 5-1. Troubleshooting Chart (continued)

Symptom	Possible Cause(s)	Solution
RGB-HD or Component HD images appear “noisy” or drop out intermittently.	<ul style="list-style-type: none"> Tracking and Phase settings need adjustment. The DHD Controller is having difficulty detecting sync pulses from the source. 	<ul style="list-style-type: none"> Adjust Tracking and Phase settings (refer to Input Position on page 44). Adjust the Sync Threshold setting (refer to Sync Threshold on page 63).
Computer images do not display correctly.	<ul style="list-style-type: none"> The resolution and frequency of the video card in the computer are not compatible with the LS-100d. 	<ul style="list-style-type: none"> Select a compatible resolution and vertical frequency (refer to Supported Timings on page 95).
Images from an HDMI source do not display.	<ul style="list-style-type: none"> The resolution and frequency of the video card in the computer are not compatible with the LS-100d. EDID compatibility issue. HDMI cable from source to DHD Controller is either defective or too long. 	<ul style="list-style-type: none"> Select a compatible resolution and vertical frequency (refer to Supported Timings on page 95). Set HDMI EDID Extension to “Off” (refer to HDMI EDID Extension on page 63). Try a known-good and/or shorter HDMI cable.
Video from an HDMI source lags behind audio.	<ul style="list-style-type: none"> Refer to Audio/Video Synchronization Issues on page 17. 	<ul style="list-style-type: none"> Use an external A/V receiver with audio delay capability to synchronize the audio signal with the video signal.
The image is too large or too small.	<ul style="list-style-type: none"> Image size needs adjusting. 	<ul style="list-style-type: none"> Adjust the image size (refer to Input Position on page 44).

6. External Control

In addition to using the DHD Controller front-panel keypad or remote control unit, there are three methods of controlling the LS-100d and DHD Controller externally:

- Using a serial (RS-232) link to send ASCII commands and receive responses to those commands.
- Using discrete infrared (IR) codes to program a third-party remote control unit.
- Using an HDMI connection to send Consumer Electronics Control (CEC) commands from a BD player or other source component that supports CEC.

The following sections describe these methods.

The DHD Controller uses a simple text-based control protocol to take requests from control devices and to provide responses to such devices. This section describes how to send control messages over a serial link between the DHD Controller and an automation/control system or a PC running terminal emulation software.

6.1 Serial Communications



Note

The serial communication protocol described here replaces the serial protocol used by legacy Runco products (manufactured prior to September 2011) that include the DHD Controller.

Runco recommends using this new protocol, as it is more concise and provides greater control than the old one. However, to maintain backward compatibility with existing automation/control system modules, the legacy Runco serial protocol is also supported.

To interface the LS-100d with an automation/control system or a PC running terminal emulation software, connect it to the **Display Control** output of the DHD Controller as shown in Figure 3-1 and Figure 3-2. Connect your control system or PC to the RS-232 input of the DHD Controller as shown in Figure 3-9.

◀ RS-232 Connection and Port Configuration

Configure the RS-232 controller or PC serial port as follows: no parity, 8 data bits, 1 stop bit and no flow control. Set the baud rate to 19200, to match that of the DHD Controller RS-232 port.

Commands sent from an automation/control system or PC to the DHD Controller must have the following format:

◀ Command Format

(www:xyz) [CR]

Where:

- (and) indicate the start and end of the command data. If these characters are present, the DHD Controller assumes that valid command data is present in the command string. Otherwise, the DHD Controller ignores the command.
- www indicates the command code. This field is case insensitive; for example, PWR, pwr and PwR are all equivalent.
- :x is the destination parameter. This is an optional parameter that indicates which memory the command is referencing. This parameter is reserved for future use.

- y is the operand, which can have one of the following values:
 - ? = "Get" operand
 - + = "Increment" operand
 - = = "Set" operand
 - = "Decrement" operand
- z is the value to set for this parameter. It can have one of two formats:
 - **Integer value:** Any positive or negative number; for example, 100.
 - **String value:** Any string surrounded by double quotes; for example, "This is a string."
- [CR] is the ASCII carriage return key (0x0D).

Response Format ➤ Responses sent from the follower to the initiator shall have the following format:

(u;www:x=z) [CR]

Where:

- (and) indicate the start and end of the command data. If these characters are present, the DHD Controller assumes that valid command data is present in the command string. Otherwise, the DHD Controller ignores the command.
- "u;" indicates the response code. This is only used by followers responding to a valid CLI command received. For any response code other than 0, the follower echoes back the command received rather than filling in the fields listed below.

The response code can be one of the following:

- 0 = Command successfully processed
- 1 = Unknown command code
- 2 = Invalid operator
- 3 = Destination parameter not supported
- 4 = Setting not available
- 5 = Setting value not available
- 6 = Setting value not supported
- 7 = String too long
- 8 = Command not supported in standby mode
- 9 = Invalid parameter
- 10 = Error processing command
- 11 = Password not entered
- www indicates the command code. This field is case insensitive; for example, PWR, pwr and PwR are all equivalent.
- :x is the destination parameter. This is an optional parameter that indicates which memory the command is referencing. This parameter is reserved for future use.
- z is the new value (for Set, Increment or Decrement commands) or the current value (for Get commands) for this parameter. It can have one of two formats:
 - **Integer value:** Any positive or negative number; for example, 100.
 - **String value:** Any string surrounded by double quotes; for example, "This is a string."
- [CR] is the ASCII carriage return key (0x0D).

Here are some examples of serial commands and their responses:

◀ **Command and Response Examples**

Command	Command Data	Response
Power query when unit is powered on	(PWR?) [CR]	(0;PWR=1) [CR]
Set power to 0 (off)	(PWR=0) [CR]	(0;PWR=0) [CR]
Increment brightness from 24 to 25	(BRT+) [CR]	(0;BRT=25) [CR]
Invalid command	(ZZZ=0) [CR]	(1;ZZZ=0) [CR]
Invalid parameter (received string, expected integer)	(CON="Some string") [CR]	(9;CON="Some string") [CR]

Table 6-1 lists all supported commands.

◀ **Serial Command List**

Table 6-1. Serial Commands

Setting	Command Code	Read/Write	Inc/Dec	Min Value	Max Value	String?	Notes
Advanced Color Temp Auto Color Enable	AAC	R/W	No	0	1	No	0 = Off; 1 = On
Advanced Color Temp Diagnostic Color	AAD	R/W	No	0	6	No	0 = White 1 = Red 2 = Green 3 = Blue 4 = Yellow 5 = Cyan 6 = Magenta
Apply Image Alignment Values	AIA	R/W	No	0	1	No	0 = Off; 1 = On
Altitude	ALT	R/W	No	0	1	No	0 = Auto 1 = High
Auto New Firmware Check	ANF	R/W	No	0	1	No	0 = Off; 1 = On
Auto Power Off Enable	APE	R/W	No	0	1	No	0 = Off; 1 = On
Auto Power Off Timer	APT	R/W	Yes	1	24	No	
Auto Perform Upgrade	APU	R/W	No	0	1	No	0 = Off; 1 = On
Aspect Ratio Copy	ARC	W	No	N/A	N/A	No	Action will be performed on any setting value
Aspect Ratio Paste	ARP	W	No	N/A	N/A	No	
Aspect Ratio	ASP	R/W	No	0	6	No	0 = 4:3 1 = 16:9 2 = Letterbox 3 = VirtualWide 4 = Cinema 5 = Virtual Cinema 6 = Native

Table 6-1. Serial Commands (continued)

Setting	Command Code	Read/Write	Inc/Dec	Min Value	Max Value	String?	Notes
Advanced Color Temp Test Pattern Enable	ATP	R/W	No	0	1	No	0 = Off; 1 = On
Image Alignment Bottom Left x	BLX	R/W	Yes	-100	100	No	
Image Alignment Bottom Left y	BLY	R/W	Yes	-100	100	No	
Image Alignment Bottom Middle y	BMY	R/W	Yes	-100	100	No	
Brightness Offset	BRO	R/W	Yes	-50	50	No	Picture menu
Brightness	BRT	R/W	Yes	-50	50	No	Calibration -> Input Image menu
Image Alignment Bottom Right x	BRX	R/W	Yes	-100	100	No	
Image Alignment Bottom Right y	BRY	R/W	Yes	-100	100	No	
Blank Screen Blue	BSB	R/W	Yes	0	255	No	
Blank Screen Green	BSG	R/W	Yes	0	255	No	
Blank Screen Red	BSR	R/W	Yes	0	255	No	
CEC Enable	CEC	R/W	No	0	1	No	0 = Off; 1 = On
Chroma Delay	CHR	R/W	Yes	0	7	No	
Color Gamut	CLG	R/W	Yes	0	6	No	0 = Auto 1 = REC709 2 = SMPTE C 3 = EBU 4 = Native 5 = DCI 6 = PCE
Color Offset	CLO	R/W	Yes	-50	50	No	Picture menu
Color	CLR	R/W	Yes	-50	50	No	Calibration -> Input Image menu
Color Space	CLS	R/W	No	0	4	No	0 = REC601 1 = REC709 2 = RGB 3 = RGB Video 4 = Auto
Image Alignment Center x	CNX	R/W	Yes	-100	100	No	
Image Alignment Center y	CNY	R/W	Yes	-100	100	No	
Contrast	CON	R/W	Yes	-50	50	No	Calibration -> Input Image menu
Contrast Offset	COO	R/W	Yes	-50	50	No	Picture menu
Color Temp Simple	CTS	R/W	No	0	4	No	1 = 5500K 2 = 6500K 3 = 7500K 4 = 9300K
CUE	CUE	R/W	No	0	1	No	0 = Off; 1 = On

Table 6-1. Serial Commands (continued)

Setting	Command Code	Read/Write	Inc/Dec	Min Value	Max Value	String?	Notes
Display Blue Gain	DBG	R/W	Yes	-100	100	No	
Display Blue Offset	DBO	R/W	Yes	-100	100	No	
Default Gateway Byte 1	DE1	R/W	Yes	0	255	No	
Default Gateway Byte 2	DE2	R/W	Yes	0	255	No	
Default Gateway Byte 3	DE3	R/W	Yes	0	255	No	
Default Gateway Byte 4	DE4	R/W	Yes	0	255	No	
Diagnostic Color	DGC	R/W	No	0	6	No	0 = White 1 = Red 2 = Green 3 = Blue 4 = Yellow 5 = Cyan 6 = Magenta
Display Green Gain	DGG	R/W	Yes	-100	100	No	
Display Green Offset	DGO	R/W	Yes	-100	100	No	
DHCP	DHC	R/W	No	0	1	No	0 = Off; 1 = On
Display Red Gain	DRG	R/W	Yes	-100	100	No	
Display Red Offset	DRO	R/W	Yes	-100	100	No	
Error Notification	ERN	R/W	No	0	1	No	0 = Off; 1 = On
Error Code	ERR	R	No	0		No	0 = None 1 = Display Lamp Overtemp 2 = Display Ballast Overtemp 3 = Display Fan Init Failure 4 = Display Fan 1 Failure 5 = Display Fan 2 Failure 6 = Display Fan 3 Failure 7 = Display Fan 4 Failure 8 = Display Fan 5 Failure 9 = Display Fan 6 Failure 10 = Display Fan 7 Failure 11 = Display Fan 8 Failure 12 = Display DMD Failure 16 = Display GPIO Failure 18 = Display Processor Failure 19 = Display Hardware I2C Failure 20 = Display Software I2C Failure 22 = Display Communication Error 25 = DHD Fan 1 Failure 26 = DHD Fan 2 Failure 27 = DHD Overtemp 1 28 = DHD Overtemp 2
Film Mode	FLM	R/W	No	0	1	No	0 = Off; 1 = On
Fan 1 Speed	FN1	R/W	Yes	0	255	No	

Table 6-1. Serial Commands (continued)

Setting	Command Code	Read/Write	Inc/Dec	Min Value	Max Value	String?	Notes
Fan 2 Speed	FN2	R/W	Yes	0	255	No	
Firmware Upgrade	FWU	W	No	N/A	N/A	No	Action will be performed on any setting value
Gamma Advanced	GMA	R/W	Yes	0	20	No	
Gamma Mode	GMM	R/W	No	0	1	No	0 = Simple 1 = Advanced
Gamma Simple	GMS	R/W	No	0	6	No	0 = 2.0 1 = 1.8 2 = 2.2 3 = 2.35 4 = 2.5
HDMI Audio Format	HAF	R/W	No	0	2	No	0 = Combined 1 = HDMI Out 1 2 = HDMI Out 2
HDMI EDID Extension 1	HE1	R/W	No	0	1	No	0 = Off; 1 = On
HDMI EDID Extension 2	HE2	R/W	No	0	1	No	
HDMI EDID Extension 3	HE3	R/W	No	0	1	No	
HDMI EDID Extension 4	HE4	R/W	No	0	1	No	
HPD Toggle Rejection	HPD	R/W	No	0	1	No	0 = Off; 1 = On
Input Name 1	I01	R/W	No	N/A	N/A	Yes	12 characters maximum
Input Name 2	I02	R/W	No	N/A	N/A	Yes	
Input Name 3	I03	R/W	No	N/A	N/A	Yes	
Input Name 4	I04	R/W	No	N/A	N/A	Yes	
Input Name 5	I05	R/W	No	N/A	N/A	Yes	
Input Name 6	I06	R/W	No	N/A	N/A	Yes	
Input Name 7	I07	R/W	No	N/A	N/A	Yes	
Input Name 8	I08	R/W	No	N/A	N/A	Yes	
Input Name 9	I09	R/W	No	N/A	N/A	Yes	
Input Name 10	I10	R/W	No	N/A	N/A	Yes	
Input Name 11	I11	R/W	No	N/A	N/A	Yes	
Input Blue Gain	IBG	R/W	Yes	-32	32	No	
Input Blue Offset	IBO	R/W	Yes	-32	32	No	
Information Boot Version	IBV	R	No	N/A	N/A	Yes	
Information Copied Aspect Ratio	ICA	R	No	N/A	N/A	Yes	

Table 6-1. Serial Commands (continued)

Setting	Command Code	Read/Write	Inc/Dec	Min Value	Max Value	String?	Notes
Information Current Color Space	ICC	R	No	0	3	Yes	0 = REC601 1 = REC709 2 = RGB 3 = RGB Video
Information Copied Input Source	ICI	R	No	N/A	N/A	Yes	
Information Copied Memory Pre-set	ICM	R	No	N/A	N/A	Yes	
Information Copied Screen	ICR	R	No	N/A	N/A	Yes	
Information Copied Signal Format	ICS	R	No	N/A	N/A	Yes	
Information Display Name	IDN	R	No	N/A	N/A	Yes	
Information Firmware Version	IFV	R	No	N/A	N/A	Yes	
Input Green Gain	IGG	R/W	Yes	-32	32	No	
Input Green Offset	IGO	R/W	Yes	-32	32	No	
Information Horizontal Frequency	IHF	R	No	N/A	N/A	Yes	
Information Input Resolution	IIR	R	No	N/A	N/A	Yes	
information Micro Version	IMV	R	No	N/A	N/A	Yes	
Input Source	INS	R/W	No	0	10	No	0 = Composite 1 1 = Composite 2 2 = Composite 3 3 = Component 4 = HD 1 5 = HD 2 6 = SCART 7 = HDMI 1 8 = HDMI 2 9 = HDMI 3 10 = HDMI 4
Information Output Resolution	IOR	R	No	N/A	N/A	Yes	
IP Address Byte 1	IP1	R/W	Yes	0	255	No	
IP Address Byte 2	IP2	R/W	Yes	0	255	No	
IP Address Byte 3	IP3	R/W	Yes	0	255	No	
IP Address Byte 4	IP4	R/W	Yes	0	255	No	
Information Pixel Clock	IPC	R	No	N/A	N/A	Yes	
Input Position Height	IPH	R/W	Yes	0	20	No	
Input Position Left Right	IPL	R/W	Yes	-50	50	No	
Input Position Up Down	IPU	R/W	Yes	-50	50	No	
Input Position Width	IPW	R/W	Yes	0	50	No	

Table 6-1. Serial Commands (continued)

Setting	Command Code	Read/Write	Inc/Dec	Min Value	Max Value	String?	Notes
Input Red Gain	IRG	R/W	Yes	-32	32	No	
Input Red Offset	IRO	R/W	Yes	-32	32	No	
Information Signal Format	ISF	R	No	N/A	N/A	Yes	
Information Serial Number	ISN	R	No	N/A	N/A	Yes	
Information Sync Type	IST	R	No	0	3	No	0 = None 1 = Separate 2 = Composite 3 = Sync-on-green
Information Vertical Frequency	IVF	R	No	N/A	N/A	Yes	
Remote Key	KEY	W	No	0	63	No	1 = On 2 = Off
Remote Key Repeat	KRT	W	No	0	63	No	3 = Menu 4 = Enter 5 = Up 6 = Down 7 = Left 8 = Right 9 = 16:9 10 = 4:3 11 = Letterbox 12 = VirtualWide 13 = Video 1 14 = Component 17 = HD 1 18 = HD 2 19 = HDMI 1 20 = HDMI 2 21 = HDMI 3 22 = HDMI 4 23 = SCART 24 = Video 2 25 = Video 3 32 = Sleep Timer Off 33 = Sleep Timer 30 Mins 34 = Sleep Timer 60 Mins 35 = Sleep Timer 90 Mins 36 = Sleep Timer 2 Hours 37 = Sleep Timer 4 Hours 38 = Screen 1 39 = Screen 2 44 = Cinema 45 = Virtual Cinema 46 = Native 48 = ISF Night 49 = ISF Day 50 = Custom 1 51 = Custom 2 52 = Exit

Table 6-1. Serial Commands (continued)

Setting	Command Code	Read/Write	Inc/Dec	Min Value	Max Value	String?	Notes
Language	LAN	R/W	No	0	9	No	0 = English 1 = French 2 = German 3 = Italian 4 = Spanish 5 = Portuguese 6 = Simplified Chinese 7 = Traditional Chinese 8 = Swedish 9 = Russian 10 = Japanese 11 = Korean
Image Alignment Left Middle x	LMX	R/W	Yes	-100	100	No	
Image Alignment Left Middle y	LMY	R/W	Yes	-100	100	No	
Lamp Life Notification Enable	LNE	R/W	No	0	1	No	0 = Off; 1 = On
Lamp Life Notification Hours	LNH	R/W	Yes	100	10,000	No	
Logo LED Brightness	LOG	R/W	Yes	0	31	No	
Model Name	MDL	R	No	N/A	N/A	Yes	
Memory Preset	MMP	R/W	No	0	3	No	0 = ISF Night 1 = ISF Day 2 = Custom 1 3 = Custom 2
Memory Preset Copy	MPC	W	No	N/A	N/A	No	Action will be performed on any setting value
Memory Preset Paste	MPP	W	No	N/A	N/A	No	
Memory Preset Reset	MPR	W	No	0	3	No	0 = ISF Night 1 = ISF Day 2 = Custom 1 3 = Custom 2
Memory Preset Save	MPS	W	No	0	3	No	
Noise Filter	NFL	R/W	Yes	0	10	No	
Noise Filter Offset	NFO	R/W	Yes	0	10	No	
Orientation	ORI	R/W	No	0	4	No	0 = Floor Front 1 = Ceiling Front 2 = Floor Rear 3 = Ceiling Rear 4 = Auto
OSD Position Horizontal	OSD	R/W	Yes	0	100	No	
Output Shift Height	OSH	R/W	Yes	-50	0	No	
Output Shift Left Right	OSL	R/W	Yes	-300	300	No	
OSD Message Enable	OSM	R/W	No	0	1	No	0 = Off; 1 = On

Table 6-1. Serial Commands (continued)

Setting	Command Code	Read/Write	Inc/Dec	Min Value	Max Value	String?	Notes
OSD Timer	OST	R/W	Yes	0	60	No	Values from 1-4 are not allowed; if increment or decrement is used, these values will be skipped.
Output Shift Up Down	OSU	R/W	Yes	-200	200	No	
OSD Position Vertical	OSV	R/W	Yes	0	100	No	
Output Shift Width	OSW	R/W	Yes	-50	0	No	
Overscan Mode	OVN	R/W	No	0	1	No	0 = Zoom 1 = Crop
Overscan	OVS	R/W	Yes	0	20	No	
PCE Blue Hue	PHB	R/W	Yes	-100	100	No	
PCE Cyan Hue	PHC	R/W	Yes	-100	100	No	
PCE Green Hue	PHG	R/W	Yes	-100	100	No	
PCE Magenta Hue	PHM	R/W	Yes	-100	100	No	
PCE Red Hue	PHR	R/W	Yes	-100	100	No	
Phase	PHS	R/W	Yes	0	31	No	
PCE Yellow Hue	PHY	R/W	Yes	-100	100	No	
PCE Blue Level	PLB	R/W	Yes	-100	100	No	
PCE Cyan Level	PLC	R/W	Yes	-100	100	No	
PCE Green Level	PLG	R/W	Yes	-100	100	No	
PCE Magenta Level	PLM	R/W	Yes	-100	100	No	
PCE Red Level	PLR	R/W	Yes	-100	100	No	
PCE Yellow Level	PLY	R/W	Yes	-100	100	No	
Periodic Notification Enable	PNE	R/W	No	0	1	No	0 = Off; 1 = On
Periodic Notification Months	PNM	R/W	Yes	1	255	No	
PCE Blue Saturation	PSB	R/W	Yes	-100	100	No	
PCE Cyan Saturation	PSC	R/W	Yes	-100	100	No	
PCE Green Saturation	PSG	R/W	Yes	-100	100	No	
PCE Magenta Saturation	PSM	R/W	Yes	-100	100	No	
PCE Red Saturation	PSR	R/W	Yes	-100	100	No	
PCE Yellow Saturation	PSY	R/W	Yes	-100	100	No	
PCE Blue White Balance Gain	PWB	R/W	Yes	-100	100	No	
PCE Red White Balance Gain	PWD	R/W	Yes	-100	100	No	
PCE Green White Balance Gain	PWG	R/W	Yes	-100	100	No	

Table 6-1. Serial Commands (continued)

Setting	Command Code	Read/Write	Inc/Dec	Min Value	Max Value	String?	Notes
Power	PWR	R/W	No	0	1	No	0 = Off; 1 = On
Input Name 1 Restore	R01	W	No	N/A	N/A	No	Action will be performed on any setting value
Input Name 2 Restore	R02	W	No	N/A	N/A	No	
Input Name 3 Restore	R03	W	No	N/A	N/A	No	
Input Name 4 Restore	R04	W	No	N/A	N/A	No	
Input Name 5 Restore	R05	W	No	N/A	N/A	No	
Input Name 6 Restore	R06	W	No	N/A	N/A	No	
Input Name 7 Restore	R07	W	No	N/A	N/A	No	
Input Name 8 Restore	R08	W	No	N/A	N/A	No	
Input Name 9 Restore	R09	W	No	N/A	N/A	No	
Input Name 10 Restore	R10	W	No	N/A	N/A	No	
Input Name 11 Restore	R11	W	No	N/A	N/A	No	
Remote Code	RMC	R/W	Yes	0	31	No	
Image Alignment Right Middle x	RMX	R/W	Yes	-100	100	No	
Remote Network Control	RNC	R/W	No	0	1	No	0 = Off; 1 = On
SatCo	SAT	R/W	No	0	3	No	0 = Off; 2 = Low; 3 = High
Standby LED Enable	SBL	R/W	No	0	1	No	0 = Off; 1 = On
Splash Configure String 1	SC1	R/W	No	N/A	N/A	Yes	30 characters max
Splash Configure String 2	SC2	R/W	No	N/A	N/A	Yes	
Splash Configure String 3	SC3	R/W	No	N/A	N/A	Yes	
Sidebar Color Blue	SCB	R/W	Yes	0	255	No	
Sidebar Color Green	SCG	R/W	Yes	0	255	No	
Screen	SCN	R/W	No	0	1	No	0 = Screen 1 1 = Screen 2
Sidebar Color Red	SCR	R/W	Yes	0	255	No	
Send Errors to Runco	SER	R/W	No	0	1	No	0 = Off; 1 = On
Sharpness Offset	SHO	R/W	Yes	-50	50	No	Picture menu
Sharpness	SHP	R/W	Yes	-50	50	No	Calibration -> Input Image menu
Screen Masking Bottom	SMB	R/W	Yes	0	200	No	
Screen Masking Test Pattern Enable	SME	R/W	No	0	1	No	0 = Off; 1 = On
Screen Masking Left	SML	R/W	Yes	0	200	No	

Table 6-1. Serial Commands (continued)

Setting	Command Code	Read/Write	Inc/Dec	Min Value	Max Value	String?	Notes
Screen Masking Test Pattern Mode Enable	SMM	R/W	No	0	1	No	0 = Off; 1 = On
Screen Masking Right	SMR	R/W	Yes	0	200	No	
Screen Masking Top	SMT	R/W	Yes	0	200	No	
Splash Enable	SPE	R/W	No	0	1	No	0 = Off; 1 = On
Splash Timer	SPT	R/W	Yes	5	60	No	
Status	STA	R	No	0	4	No	
Sync Threshold	STH	R/W	Yes	0	15	No	
Sleep Timer	STM	R/W	No	0	5	No	0 = Off 1 = 30 Minutes 2 = 60 Minutes 3 = 90 Minutes 4 = 2 Hours 5 = 4 Hours
Subnet Mask Byte 1	SU1	R/W	Yes	0	255	No	
Subnet Mask Byte 2	SU2	R/W	Yes	0	255	No	
Subnet Mask Byte 3	SU3	R/W	Yes	0	255	No	
Subnet Mask Byte 4	SU4	R/W	Yes	0	255	No	
System Reset	SYS	W	No	N/A	N/A	No	Action will be performed on any setting value

Table 6-1. Serial Commands (continued)

Setting	Command Code	Read/Write	Inc/Dec	Min Value	Max Value	String?	Notes
Trigger 1 16:9	T11	R/W	No	0	1	No	0 = Off; 1 = On
Trigger 1 4:3	T12	R/W	No	0	1	No	
Trigger 1 Letterbox	T13	R/W	No	0	1	No	
Trigger 1 VirtualWide	T14	R/W	No	0	1	No	
Trigger 1 Cinema	T15	R/W	No	0	1	No	
Trigger 1 Virtual Cinema	T16	R/W	No	0	1	No	
Trigger 1 Native	T17	R/W	No	0	1	No	
Trigger 2 16:9	T21	R/W	No	0	1	No	
Trigger 2 4:3	T22	R/W	No	0	1	No	
Trigger 2 Letterbox	T23	R/W	No	0	1	No	
Trigger 2 VirtualWide	T24	R/W	No	0	1	No	
Trigger 2 Cinema	T25	R/W	No	0	1	No	
Trigger 2 Virtual Cinema	T26	R/W	No	0	1	No	
Trigger 2 Native	T27	R/W	No	0	1	No	
Trigger 3 16:9	T31	R/W	No	0	1	No	
Trigger 3 4:3	T32	R/W	No	0	1	No	
Trigger 3 Letterbox	T33	R/W	No	0	1	No	
Trigger 3 VirtualWide	T34	R/W	No	0	1	No	
Trigger 3 Cinema	T35	R/W	No	0	1	No	
Trigger 3 Virtual Cinema	T36	R/W	No	0	1	No	
Trigger 3 Native	T37	R/W	No	0	1	No	
Image Alignment Top Left x	TLX	R/W	Yes	-100	100	No	
Image Alignment Top Left y	TLY	R/W	Yes	-100	100	No	
Image Alignment Top Middle x	TMX	R/W	Yes	-100	100	No	
Image Alignment Top Middle y	TMY	R/W	Yes	-100	100	No	
Tint Offset	TNO	R/W	Yes	-50	50	No	Picture menu
Tint	TNT	R/W	Yes	-50	50	No	Calibration -> Input Image menu
Test Pattern Enable	TPE	R/W	No	0	1	No	0 = Off; 1 = On
Primary Test Pattern	TPP	R/W	No	0	1	No	0 = Off; 1 = On
Secondary Test Pattern	TPS	R/W	No	0	1	No	0 = Off; 1 = On
Tracking	TRK	R/W	Yes	-100	100	No	
Image Alignment Top Right x	TRX	R/W	Yes	-100	100	No	

Table 6-1. Serial Commands (continued)

Setting	Command Code	Read/Write	Inc/Dec	Min Value	Max Value	String?	Notes
Image Alignment Top Right y	TRY	R/W	Yes	-100	100	No	
Test Video	TST	R/W	No	0	4	No	1 = Color Bars 1 11 = Color Bars 2 12 = Gray Bars 13 = Focus 14 = Off 15 = Off (Restore OSD)
VFD Brightness	VFD	R/W	Yes	0	4	No	0 = 0% 1 = 25% 2 = 50% 3 = 75% 4 = 100%

The DHD Controller accepts commands in the form of IR signals that conform to the Phillips RC5 protocol. Each DHD Controller remote control button has an RC5 control code associated with it.

You can use these codes to program a third-party, “universal” remote control unit to work with the DHD Controller. These third-party products usually come with a computer software application for this purpose. For more information, consult the documentation provided with the remote control unit.

The IR control codes have the following characteristics:

- Each code consists of 14 bits:
 - Two (2) **start bits** (always 1);
 - A **toggle bit**. This bit is inverted every time a key is released and pressed again. This enables the DHD Controller to distinguish between a button that remains down and one that is pressed repeatedly.
 - Five (5) **address bits**. The default address is **17** (binary 10001). To change it, select Remote Code from the Miscellaneous menu (in the Service menu) and follow the steps given on page 62.
 - Six (6) **data bits**.
- The carrier frequency is 36 kHz, with the modulated pulses having a 25% duty cycle.
- Commands are sent at a maximum rate of 9 Hz.

For example, here is the RC5 control code for the **ON** button on the DHD Controller remote control unit (assuming the default address is used):

With Toggle Bit = 0														
Hex	3		4				4				1			
Binary	1	1	0	1	0	0	0	1	0	0	0	0	0	1
With Toggle Bit = 1														
Hex	3		C				4				1			
Binary	1	1	1	1	0	0	0	1	0	0	0	0	0	1
Function	Start Bits	Toggle Bit	Address				Command							

Figure 6-1 shows the pulse train for this command (with the toggle bit set to zero).

6.2 Using Discrete IR Codes

➤ IR Command Protocol

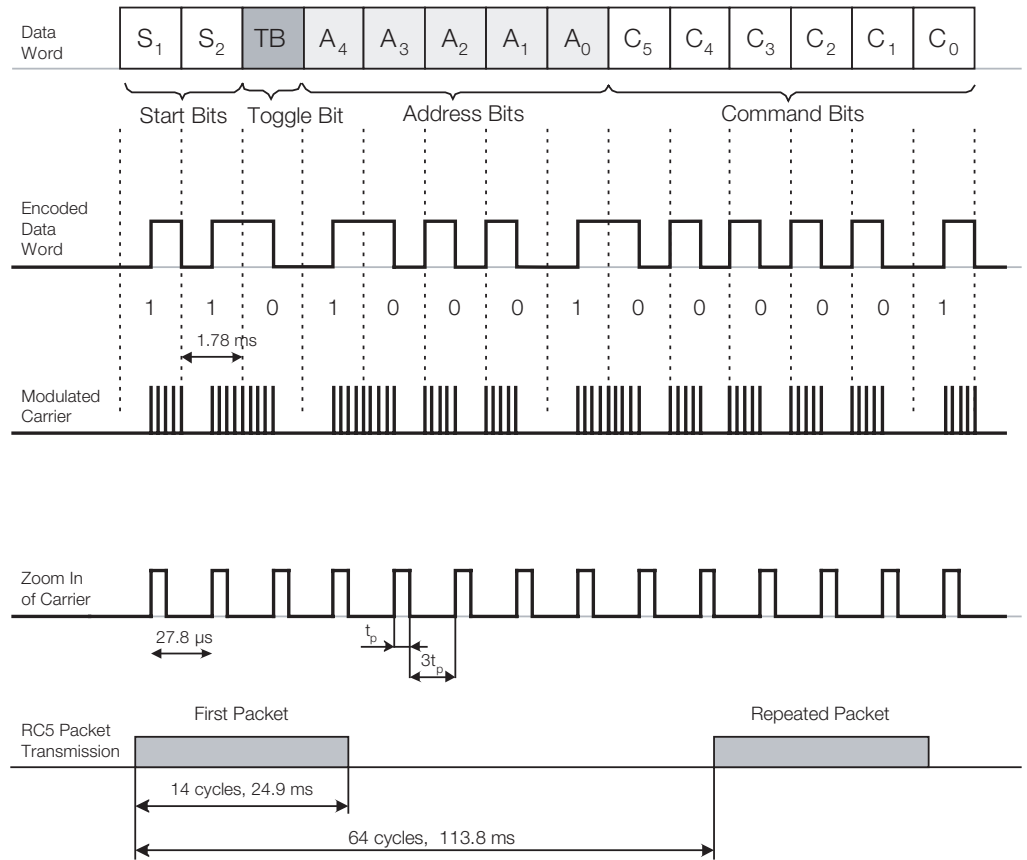

Figure 6-1. RC5 Message Format

Table 6-2 lists the RC5 control codes for the DHD Controller.



IR Command List

Table 6-2. RC5 Control Codes for the DHD Controller

Function	RC5 Data from Remote Control (Note)	RC5 Data with Toggle Bit = 1 (Note)	Description
16:9	0x3449	0x3C49	16:9 aspect ratio
4:3	0x344A	0x3C4A	4:3 aspect ratio
CINEMA	0x346C	0x3C6C	Cinema aspect ratio
COMP	0x344E	0x3C4E	Component video input
CUST 1	0x3472	0x3C72	Custom 1 memory preset
CUST 2	0x3473	0x3C73	Custom 2 memory preset
DOWN	0x3446	0x3C46	Down-Arrow (▼)
ENTER	0x3444	0x3C44	ENTER
EXIT	0x3474	0x3C74	EXIT
HD 1	0x3451	0x3C51	HD1 video input
HD 2	0x3452	0x3C52	HD2 video input
HDMI 1	0x3453	0x3C53	HDMI1 video input
HDMI 2	0x3454	0x3C54	HDMI2 video input
HDMI 3	0x3455	0x3C56	HDMI3 video input
HDMI 4	0x3456	0x3C56	HDMI4 video input
ISF DAY	0x3471	0x3C71	ISF Day memory preset
ISF NT	0x3470	0x3C70	ISF Night memory preset
LEFT	0x3447	0x3C47	Left-Arrow (◀)
LET BOX	0x344B	0x3C4B	Letterbox aspect ratio
MENU	0x3443	0x3C43	MENU
NATIVE	0x346E	0x3C6E	Native aspect ratio
OFF	0x3442	0x3C42	Power off
ON	0x3441	0x3C41	Power on
RIGHT	0x3448	0x3C48	Right-Arrow (▶)
SCART	0x3457	0x3C57	SCART video input
SCREEN1	0x3466	0x3C66	Selects "Screen 1"
SCREEN2	0x3467	0x3C67	Selects "Screen 2"

Note: These codes assume that the default address of 17 is used. If you change it to something other than 17, you will need to modify these codes accordingly.

Table 6-2. RC5 Control Codes for the DHD Controller (continued)

Function	RC5 Data from Remote Control (Note)	RC5 Data with Toggle Bit = 1 (Note)	Description
STOFF	0x3460	0x3C60	Sets the sleep timer to Off
ST30MIN	0x3461	0x3C61	Sets the sleep timer to 30 minutes
ST60MIN	0x3462	0x3C62	Sets the sleep timer to 60 minutes
ST90MIN	0x3463	0x3C63	Sets the sleep timer to 90 minutes
ST2HRS	0x3464	0x3C64	Sets the sleep timer to 2 hours
ST4HRS	0x3465	0x3C65	Sets the sleep timer to 4 hours
UP	0x3445	0x3C45	Up-Arrow (▲)
VID 1	0x344D	0x3C4D	Composite video input 1
VID 2	0x3458	0x3C58	Composite video input 2
VID 3	0x3459	0x3C59	Composite video input 3
V-CINE	0x346D	0x3C6D	Virtual Cinema aspect ratio
V-WIDE	0x344C	0x3C4C	VirtualWide aspect ratio

Note: These codes assume that the default address of 17 is used. If you change it to something other than 17, you will need to modify these codes accordingly.

The DHD Controller accepts and can respond to CEC command messages from a disc player, satellite receiver or DVR/set-top box via an HDMI connection. Using CEC, the DHD Controller can perform the following actions:

- Turn itself and the display device on and select the correct input when the source component initiates playback of a disc or recorded program.
- Turn the source component on when you switch to its corresponding input on the DHD Controller.
- Turn the source component off when the DHD Controller is turned off (unless the source component is in playback mode).
- Change its OSD language when a similar change is made at the source.

To use CEC, connect your CEC-compatible sources to the HDMI inputs on the LS-100d. Set the CEC option to **On** (refer to **CEC** on page 63). Additional steps may be needed to enable CEC at the source. Refer to the documentation for your source device for more information.

Table 6-3 lists the CEC commands supported by the DHD Controller.

6.3 Using HDMI CEC Messages

➤ CEC Command List

Table 6-3. CEC Commands Supported by the DHD Controller

Opcode	Value	Supported? (√ = Yes, – = No)	
		Initiator	Follower
Feature Abort	0x00	√	√
Standby	0x36	√	√
Routing Change	0x80	√	√
Routing Information	0x81	√	√
Active Source	0x82	√	√
Request Active Source	0x85	√	√
Device Vendor ID	0x87	√	√
Give Device Vendor ID	0x8C	√	√
Vendor Command With ID	0xA0	√	√
Polling Message	N/A	√	√
Text View On	0x0D	√	–
Report Physical Address	0x84	√	–
Inactive Source	0x9D	√	–
CEC Version	0x9E	√	–
Set OSD Name	0x47	√	–
Menu Status	0x8E	√	–
Report Power Status	0x90	√	–
Set Menu Language	0x32	–	√

Table 6-3. CEC Commands Supported by the DHD Controller (continued)

Opcode	Value	Supported? (√ = Yes, – = No)	
		Initiator	Follower
Give Physical Address	0x83	–	√
Set Stream Path	0x86	–	√
Get CEC Version	0x9F	–	√
Abort Message	0xFF	–	√
User Control Pressed	0x44	–	√
User Control Released	0x45	–	√
Give OSD Name	0x46	–	√
Menu Request	0x8D	–	√
Give Device Power Status	0x8F	–	√

**Note**

The DHD Controller does not transmit HDMI CEC control messages from the “HDMI Audio Out” connector.

Notes:

7. Specifications

Table 7-1 lists the LS-100d specifications.

Table 7-1. LS-100d Specifications

Projector Type:	Digital Light Processing™ (DLP™), Single-Chip, 16:9 SuperOnyx™ DMD™ with InfiniLight™ Illumination
Illumination:	RGB InfiniLight™ LEDs for 135% NTSC color gamut with Personal Color Equalizer™
Native Resolution:	Full HD, 1920 x 1080 (16:9)
Aspect Ratios:	Refer to Table 7-2
Video Standards:	Refer to Table 7-2
Video Compatibility:	480i, 480p, 576i, 576p, 720p, 1080i 50/60, 1080p 24/50/60
Picture Size (16:9 Screen):	Recommended Width: 77 in. (1.96 m) to 86 in. (2.18 m) Maximum Width: 86 in. (2.18 m)
Processing:	Runco DHD4 Processor with ViVix IV™ technology and BRiC (Backup, Recovery and Clone) tool
Control Options:	<ul style="list-style-type: none">• Serial commands via RS-232• Discrete infrared (IR) remote• Consumer Electronics Control (CEC) protocol support via HDMI• Ethernet
Calibration:	ISF Certified Calibration Configuration
Color Gamut:	Fully adjustable, > BT.709 (REC709)
Projection Distance:	Refer to Table 3-2
Horizontal/Vertical Offset:	None
Inputs (from DHD Controller):	(1) HDMI with HDCP (1) RS-232

7.1 LS-100d Specifications

Table 7-1. LS-100d Specifications (continued)

Brightness and Contrast:	<p>Cinema Standards Measurement System (CSMS) Specifications</p> <ul style="list-style-type: none"> - Brightness: 12.7 foot-Lamberts (fL) - Contrast Ratio: 330:1 <p>These measurements are taken from the projector in a controlled, home theater environment. All measurements are made to ANSI/NAPM IT7.228-1997 specifications using the Photo Research PR-650 SpectraColorimeter and Minolta LS-100 Luminance Meter, Video Essentials test DVD and a DNS rear-projection, 1.0 gain, 77-inch wide Fresnel screen. The projector is calibrated to a color temperature of 6,500K and has a minimum of 150 hours of usage. The foot-Lambert (fL) is the unit of measurement used in commercial movie theaters to express image brightness at the screen surface. The Society of Motion Picture and Television Engineers (SMPTE) specifies 16 fL as the target image brightness for film-based projectors using an open gate (without film in the projector). More importantly, today SMPTE specifies 12 fL as the target image brightness in Digital Cinema theaters. The foot-Lambert measurement is dependent on screen size, screen gain and projector light output.</p> <p>Home Theater Calibration Specifications</p> <ul style="list-style-type: none"> - Light Output: 350 ANSI Lumens - Contrast Ratio: 330:1 <p>These specifications are obtained by calibrating the projector as described above for CSMS measurements.</p> <p>Industry-Standard Specifications</p> <ul style="list-style-type: none"> - Light Output: 600 ANSI Lumens - Contrast Ratio: 3 settings (Infinity:1, 20,000:1, 10,000:1 (sequential)) <p>ColorContrast™</p> <p>Colors have up to 50% higher contrast than Mercury or Xenon lamp systems.</p> <p>These are typical projector brightness and contrast specifications found in most companies' sales literature. Runco includes these measurements in its literature to allow for direct comparison with other manufacturers' projectors. These measurements are typically taken at 9,000K to 13,000K to get expected performance data when the projector is used in professional, commercial and industrial displays.</p>
Power Requirements:	100 to 240 VAC (auto-sensing), 50/60 Hz, 240 watts typical (477.8 BTUs/hour), 320 watts maximum
Operating Environment:	41°F to 104°F (5°C to 40°C), 10% to 85% humidity (non-condensing)
Dimensions:	See Figure 7-1
Weight (including lens):	27.5 lbs. (12.5 kg)
Regulatory Approvals:	FCC Part 15 Class B, CE Class B, UL, cUL, CB, RoHS, WEEE, local conformances as required
Limited Warranty:	Two (2) years parts and labor from the date of shipment from Runco. Extended RuncoCare™, RedCarpet™, and PremierCare™ assurance available.
Maintenance:	Zero maintenance, solid state optical path.
Specifications are subject to change without notice.	

Table 7-2 lists the DHD Controller specifications.

Table 7-2. DHD Controller Specifications

Aspect Ratios:	4:3, Letterbox, 16:9, VirtualWide, Cinema, Virtual Cinema, Native
Video Standards:	<ul style="list-style-type: none"> • HDMI and DVI with HDCP for digital video • Component and RGB HDTV (1080p, 1080i, 720p) • Component and RGB EDTV (576p, 480p) • Component and Composite SDTV (576i, 480i) • RGB SCART with adaptor • NTSC (M, 4.43) • PAL (B, G, H, I, N, M) • SECAM (M)
Inputs:	<ul style="list-style-type: none"> (4) HDMI with CEC and Deep Color (1) Component/SCART (3 x RCA) (2) Component/RGBHV (5 x BNC) (3) Composite
Outputs:	<ul style="list-style-type: none"> (1) HDMI with Deep Color to LS-100d (1) HDMI with Deep Color to second display or audio processor
Control Options:	<ul style="list-style-type: none"> • Front panel vacuum fluorescent display and keypad • Discrete infrared (IR) remote • RS-232 (female DB9) for serial commands • USB (type B female) for firmware upgrade • RS-232 (male DB9) for accessories • 3.5-mm wired IR input for Niles/Xantech-compatible IR systems • Consumer Electronics Control (CEC) protocol support via HDMI • Ethernet
Ethernet Communication:	RJ45 (female) for web server, e-mail, auto firmware upgrade and Telnet
RS-232 Communication Parameters:	19200 bps, no parity, 8 data bits, 1 stop bit, no flow control
Trigger Outputs:	(3) +12 VDC, each rated at 250 mA and thermal fuse-protected
Accessory Applications:	Runco Firmware Upgrader, Runco BRiC (backup, restore, clone), CalMAN by SpectraCal for automatic calibration
Power Requirements:	100-240V~, 47-63Hz, 0.45 Amps
Operating Environment:	41°F to 104°F (5°C to 40°C), 0% to 90% humidity (non-condensing); up to 10,000 feet (3,048 meters) altitude
Dimensions:	<ul style="list-style-type: none"> Width = 17.50 inches (444.5 mm) Depth = 11.19 inches (284.1 mm) Height = 3.75 inches (95.3 mm)
Weight:	15.4 lbs. (7.00 kg)

7.2 DHD Controller Specifications

Table 7-2. DHD Controller Specifications (continued)

Regulatory Approvals:	cTUVus, FCC class B, CE, RoHS, China RoHS, WEEE, C-Tick, CCC, local conformances as required
Limited Warranty:	Two (2) years parts and labor from the date of shipment from Runco.

Specifications are subject to change without notice.

7.3 Overall Dimensions - LS-100d

Figure 7-1 shows the LS-100d dimensions (all dimensions are in millimeters).

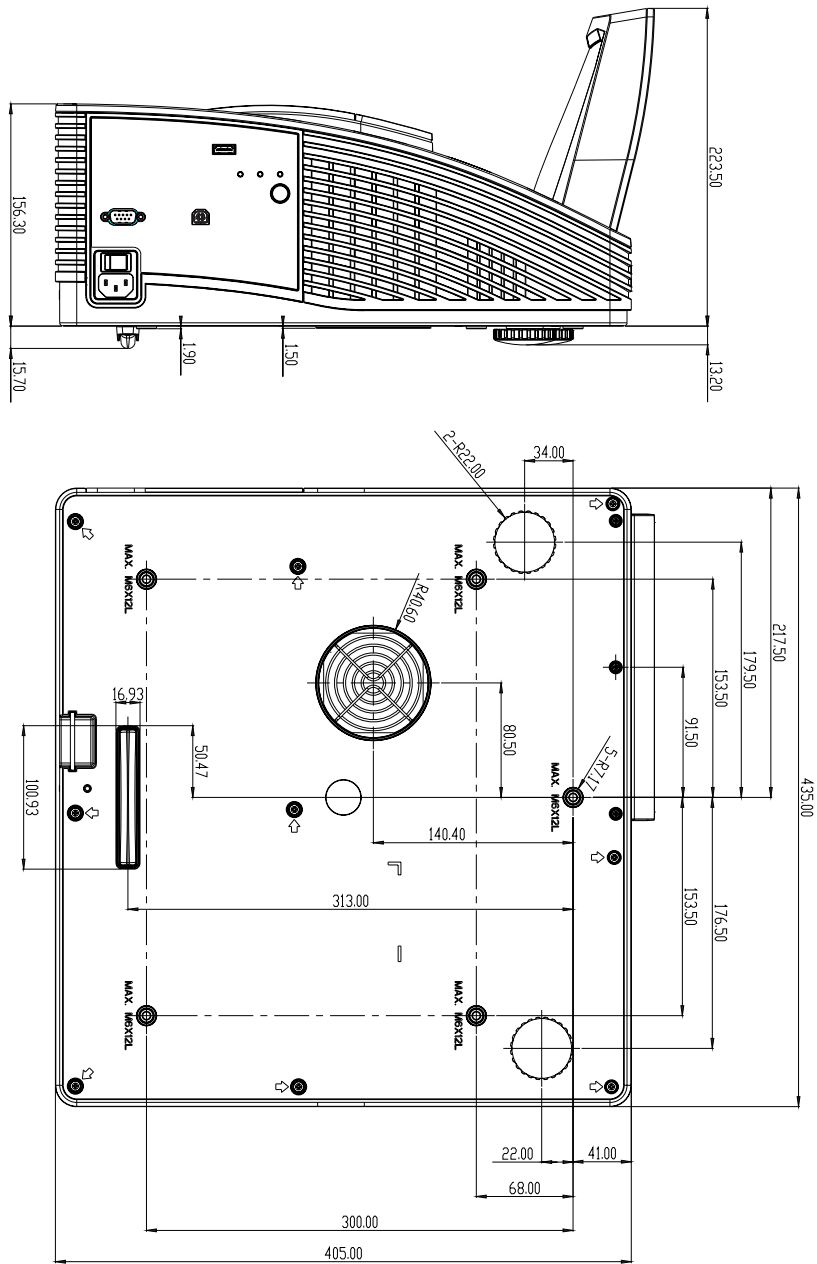

Figure 7-1. Overall Dimensions - LS-100d

Table 7-3 lists the signal types supported by each input on the DHD Controller.

7.4 Supported Timings

Table 7-3. Supported Signal Timings by Input

Format	Resolution	Refresh Rate (Hz)	Horizontal Frequency (kHz)	Pixel Frequency (MHz)	Supported? (√ = Yes, – = No)				
					HD 1 HD 2	HDMI 1 HDMI 2 HDMI 3 HDMI 4	Component	SCART	Composite 1 Composite 2 Composite 3
640x480	640x480	60.00	31.469	25.175	√	√	√	–	–
		66.59	35.892	29.862	√	√	√	–	–
		72.00	37.861	31.500	√	√	√	–	–
		75.00	37.500	31.500	√	√	√	–	–
		85.00	43.269	36.000	√	√	√	–	–
800x600	800x600	60.00	37.879	40.000	√	√	√	–	–
		72.00	48.077	50.000	√	√	√	–	–
		75.00	46.875	49.500	√	√	√	–	–
		85.00	53.674	56.250	√	√	√	–	–
832x624	832x624	74.54	52.849	60.036	√	√	√	–	–
848x480	848x480	47.95	25.270	27.089	√	√	√	–	–
		60.00	31.020	33.750	√	√	√	–	–
1024x768	1024x768	60.00	48.363	65.000	√	√	√	–	–
		70.00	56.476	75.000	√	√	√	–	–
		75.00	60.023	78.750	√	√	√	–	–
		85.00	68.677	94.500	√	√	√	–	–
1152x864	1152x864	75.00	67.500	108.000	√	√	√	–	–
1280x720	1280x720	47.95	37.833	64.769	√	√	√	–	–
1280x768	1280x768	60.00	47.396	68.250	√	√	√	–	–
		60.00	47.776	79.500	√	√	√	–	–
		75.00	60.289	102.250	√	√	√	–	–
		85.00	68.633	117.500	√	√	√	–	–
1280x960	1280x960	60.00	60.000	108.000	√	√	√	–	–
		85.00	85.938	148.500	√	√	√	–	–
1280x1024	1280x1024	60.00	63.981	108.000	√	√	√	–	–
		75.00	79.976	135.000	√	√	√	–	–
		85.00	91.146	157.500	√	√	√	–	–

Table 7-3. Supported Signal Timings by Input (continued)

Format	Resolution	Refresh Rate (Hz)	Horizontal Frequency (kHz)	Pixel Frequency (MHz)	Supported? (√ = Yes, – = No)				
					HD 1 HD 2	HDMI 1 HDMI 2 HDMI 3 HDMI 4	Component	SCART	Composite 1 Composite 2 Composite 3
1360x768	1360x768	60.00	47.712	85.500	√	√	√	–	–
1400x1050	1400x1050	60.00	64.744	101.000	√	√	√	–	–
		60.00	65.317	121.750	√	√	√	–	–
		75.00	82.278	156.000	√	√	√	–	–
1600x1200	1600x1200	60.00	75.000	162.000	√	√	√	–	–
1680x1050	1680x1050	60.00	64.674	119.000	√	√	√	–	–
1920x1080	1920x1080	47.95	56.821	150.007	√	√	√	–	–
1920x1200	1920x1200	60.00	74.038	154.000	√	√	√	–	–
SCART RGSB	–	50.00	–	–	–	–	–	√	–
480/60i	720x487	59.94	15.734	13.500	√	√	√	–	–
480/60p	720x483	59.94	31.469	27.000	√	√	√	–	–
576/50i	720x576	50.00	15.625	14.750	√	√	√	–	–
576/50p	720x576	50.00	31.250	29.000	√	√	√	–	–
720/24p	1280x720	23.98/24.00	17.982/18.000	59.341/59.400	√	√	√	–	–
720/25p	1280x720	25.00	18.750	74.250	√	√	√	–	–
720/30p	1280x720	29.97/30.00	22.478/22.500	74.175/74.250	√	√	√	–	–
720/50p	1280x720	50.00	37.500	75.250	√	√	√	–	–
720/60p	1280x720	60.00	45.000	74.250	√	√	√	–	–
1080/50i	1920x1080	50.00	28.125/31.250	74.250/72.000	√	√	√	–	–
1080/60i	1920x1080	59.94/60.00	33.716/33.750	74.175/74.250	√	√	√	–	–
1080/24p	1920x1080	23.98/24.00	26.978/27.000	74.175/74.250	√	√	√	–	–
1080/50p	1920x1080	50.00	56.250	148.500	√	√	√	–	–
1080/60p	1920x1080	59.94/60.00	67.433/67.500	148.350/148.500	√	√	√	–	–
NTSC 3.58	–	59.94/60.00	15.734/15.750	3.580	–	–	–	–	√
NTSC 4.43	–	59.94/60.00	15.734/15.750	4.430	–	–	–	–	√
PAL-B/G/H/I	–	50.00	15.625	4.430	–	–	–	–	√
PAL-M	–	59.94/60.00	15.734/15.750	3.580	–	–	–	–	√
PAL-N	–	50.00	15.625	3.580	–	–	–	–	√
SECAM	–	50.00	15.625	13.500	–	–	–	√	√

020-1174-00 Rev. A
December 2011

Runco International • (800) 23RUNCO • Fax (503) 748-8161 • www.runco.com

Free Manuals Download Website

<http://myh66.com>

<http://usermanuals.us>

<http://www.somanuals.com>

<http://www.4manuals.cc>

<http://www.manual-lib.com>

<http://www.404manual.com>

<http://www.luxmanual.com>

<http://aubethermostatmanual.com>

Golf course search by state

<http://golfingnear.com>

Email search by domain

<http://emailbydomain.com>

Auto manuals search

<http://auto.somanuals.com>

TV manuals search

<http://tv.somanuals.com>