



---

**INSTALLATION/OPERATION MANUAL**

---

# SIGNATURE CINEMA

**SC-50d Series**

**SC-60d Series**

**Full-HD Private Cinema Projector and  
Digital High Definition (DHD) Controller/Processor**





---

# RuncoCare™ Standard Two Year Limited Warranty

Congratulations on your purchase of a Runco® product! With proper installation, setup and care, you should enjoy many years of unparalleled video performance.

This RuncoCare Standard Limited Warranty is provided free of charge by Runco International, LLC (“Runco”) with the purchase of a covered Runco product. The following sets forth Runco’s Standard Limited Warranty applicable to all Runco projectors, processors, LCD display and plasma display products, with the exception of the following models: XP-103DHD, SC-1, SC-1a, CW-95DHD and VW-100HD<sup>1</sup>.

The following terms and conditions of the RuncoCare Standard Limited Warranty represent a contract between us, Runco, and you, the customer, who has purchased a Runco product. This contract applies to purchases of covered Runco products occurring on or after **February 11, 2010**. Runco reserves the right to change the terms of this contract, and such changes shall apply to purchases of covered Runco products that occur on or after any future effective date.

## RuncoCare Standard Features

- Two-year protection from defects in material and workmanship
- Access to 24x7 phone support
- Complimentary, second-day one-way shipping

## Warranty Coverage

Runco warrants its products to be free from defects in material and workmanship during the warranty period provided below. If, in Runco’s sole determination, a product proves to be defective in material or workmanship during the warranty period, Runco will repair the product, replace the product with a substantially similar new or like-new product, or refund a prorata share of the purchase price (calculated based on the remainder of the warranty period and the then-current MSRP<sup>2</sup> of a similar product), if repair or replacement of the product is determined by Runco to not be feasible. Runco has sole discretion in determining whether a same or like model is offered, and what constitutes a “substantially similar model.”

## Length of Warranty

Runco products are warranted for two (2) years from the date of shipment from Runco. Lamps are warranted six (6) months from the date of shipment or 1000 hours of use, whichever comes first. All other accessories, which include but are not limited to, cables, remotes, carrying cases, lens cap and other peripherals sold with the Runco product, are warranted for ninety (90) days from the date of the original shipment of the accessory.

## Eligibility

This RuncoCare Standard Limited Warranty is valid only for the first customer who purchases the covered product from an authorized Runco dealer or distributor. This warranty is not transferable. You may be required to provide proof of purchase in order to receive warranty services.

- 
1. Runco may update this list of products excluded from this warranty from time to time at Runco’s sole discretion, but updates to the list of covered products will not apply on a retroactive basis.
  2. MSRP is defined as the most recent product price listed on Runco’s price list.

---

## RuncoCare Claim Procedure

In the event of a product defect, please follow the warranty claim procedure provided below:

1. The Customer is required to contact a Runco dealer or Runco Technical Support via email at support@runco.com or via phone at (toll free) (800) 23RUNCO (800-237-8626). If the customer is located outside North America, call +3589 4200 554 in Europe for product service.
2. Be prepared to provide the date of purchase, the place of purchase, serial number, product model number, description of the problem and troubleshooting steps already attempted.
3. Runco Technical Support staff will attempt to correct any minor issues that may be causing the problem. If Runco is unable to resolve the problem through troubleshooting, a Return Material Authorization (RMA) number will be issued for the exchange of the defective product if it is determined that the claim was made within the coverage period of the Standard Limited Warranty.
4. If it is determined that the Standard Limited Warranty applies to the claim, the customer will need to return the defective product to the Runco repair depot location specified by the Runco technical support representative. The customer will need to properly package the defective product, consisting of the product only, and not include any accessories (e.g., cables, remotes, carrying cases, lens, lens cap and other peripherals) and return it to the Runco repair depot specified by the technical support representative. It is the customer's responsibility to properly package the hardware, include all appropriate materials, and return it to the location specified by the Runco technical support department. The customer will need to address and resolve any shipping damage claims directly with the shipping company.
5. The customer is responsible for providing a suitable box to ship the defective product to an authorized Runco repair depot. Boxes may be purchased from a Runco technical support representative.
6. The customer is responsible for paying freight charges to ship the defective product to an authorized Runco repair depot.
7. For in-warranty repairs, Runco will pay freight charges to return the repaired/replacement product (which shall not include accessories--e.g., cables, remotes, carrying cases, lens cap and other peripherals sold with the Runco product) to the customer from the Runco repair depot.
8. Once an RMA has been created, the customer may contact serviceorders@runco.com for followup questions or confirmation status of the claim process.

## Warranty Exclusions

This RuncoCare Standard Limited Warranty does not include or is limited by the following:

1. Products not purchased from an authorized Runco dealer
2. Rental costs incurred by the customer in the event of product defect or failure
3. Any product with a defaced, modified, or removed serial number
4. Damage, deterioration, or malfunction resulting from:
  - a Accident, abuse, misuse, neglect, improper ventilation, fire, water, disaster, lightning, or other acts of nature, smoke exposure (cigarette or otherwise), unauthorized product modification (including use of an unauthorized mount), or failure to follow instructions supplied with the product
  - b Repair or attempted repair by anyone not authorized by Runco
  - c Any damage to the product due to shipment
  - d Removal or installation of the product
  - e Causes external to the product, such as electric power fluctuations or failure
  - f Use of supplies or parts (including lamps) that are not purchased from Runco or do not meet Runco's specifications
  - g Normal wear and tear

- 
- h Expected lamp degradation and normal decrease in lamp output over a period of time or as the lamp is consumed
  - i Customer caused defects, including but not limited to, scratched/defaced/altered plastics
  - j Failure to follow maintenance procedures as outlined in the product's user guide where a schedule is specified for regular cleaning of the product
  - k Opening the product and/or tampering with internal circuitry
  - l Products lost, stolen or discarded
  - m Any damage or dissatisfaction associated with latent images, "burnin," or any other damage determined by Runco to be the result of customer use patterns
  - n Any other cause, which does not relate to a product defect in material or workmanship
5. Removal, installation, and setup service charges are excluded from this Standard Limited warranty
  6. Black uniformity issues or other LCD issues associated with usage outside the Runco recommended guidelines and specifications for the product
  7. Bright or dark sub pixels that are characteristic of LCD technology and considered by Runco to be acceptable and within Runco's manufacturing specifications. (See "Sub Pixel Policy," below.)
  8. Second day shipment delivery time and availability may vary based on origin and destination and Runco is unable to deliver to PO Box and FPO Box addresses

### **Sub Pixel Policy**

It is not uncommon for one or more sub pixels to become bright or dark during or after the manufacturing process. A bright sub pixel is one that remains in the on position, and a dark sub pixel is one that appears black or off. The sub pixels are usually hard to see and will not detract from the display quality or usability at normal viewing distance. The following are Runco's criteria for identifying bright or dark sub pixels that would be considered unacceptable: a) the number of bright or dark sub pixels; b) the location of the bright or dark sub pixels; c) the color of the bright sub pixels; and d) the Runco model size. If sub pixels have been identified as unacceptable by Runco the LCD will be deemed faulty and will be replaced if reported within the warranty period. If there are issues with bright or dark sub pixels, gather the information listed above and call or email [support@runco.com](mailto:support@runco.com).

### **Other Terms and Conditions**

1. Runco will not accept returned Product unless an RMA number has been issued by Runco.
2. If an Advance Exchange return occurs, it is the customer's responsibility to properly package the defective product and ship it to the address provided by the Runco technical support representative with the RMA number prominently displayed. If the defective product is not properly packaged and is damaged in transit during its return to Runco, you may be invoiced for either the repair costs, if repairable, or the MSRP of a replacement product and shipping costs incurred by Runco.
3. The repaired or replaced product will assume the remainder of your original product's RuncoCare Service Plan term or 90 days from the date the repaired unit is shipped, whichever is longer.
4. If a replacement product is sent, the customer agrees to retain the replacement for the product you purchased and your defective product becomes the property of Runco.

### **Extended Service Options**

Runco offers extended and expanded service plans. For information on additional product protection, please email [serviceorders@runco.com](mailto:serviceorders@runco.com) or call (toll free) (800) 23RUNCO (800-237-8626).

---

## **Online Product Registration**

Please visit <http://www.runco.com/support/product-registration/> to register product.

## **Limitation of Implied Warranties**

RUNCO PROVIDES NO WARRANTIES, EXPRESS OR IMPLIED, EXCEPT THOSE EXPRESSLY PROVIDED HEREIN. RUNCO EXPRESSLY DISCLAIMS ALL OTHER WARRANTIES, INCLUDING THE IMPLIED WARRANTIES OF MERCHANTABILITY AND FITNESS FOR A PARTICULAR PURPOSE.

## **Exclusion of Damages**

RUNCO'S MAXIMUM AGGREGATE LIABILITY HEREUNDER IS LIMITED TO THE COST OF REPAIR OR REPLACEMENT OF THE PRODUCT.

1. RUNCO SHALL NOT BE LIABLE FOR DAMAGE TO OTHER PROPERTY CAUSED BY ANY DEFECT IN THE PRODUCT, DAMAGES BASED UPON INCONVENIENCE, LOSS OF USE OF THE PRODUCT, LOSS OF TIME, LOSS OF PROFITS, LOSS OF BUSINESS OPPORTUNITY, LOSS OF GOODWILL, INTERFERENCE WITH BUSINESS RELATIONSHIPS, OR OTHER COMMERCIAL LOSS, EVEN IF THE CUSTOMER HAS BEEN ADVISED OF THE POSSIBILITY OF SUCH DAMAGES.
2. RUNCO SHALL NOT BE LIABLE FOR ANY CONSEQUENTIAL, INCIDENTAL, INDIRECT, SPECIAL, OR PUNITIVE DAMAGES.
3. RUNCO SHALL NOT BE LIABLE FOR ANY CLAIM AGAINST THE CUSTOMER BY ANY OTHER PARTY.

## **Effect of Local Law**

This warranty gives you specific legal rights, and you may have other rights, which vary from locality to locality. Some localities do not allow limitations on implied warranties and/or do not allow the exclusion of incidental or consequential damages, so the above limitations and exclusions may not apply to you.

## **COPYRIGHT AND TRADEMARKS:**

© Copyright 2011 Runco International, LLC ("Runco"). This document contains proprietary information protected by copyright, trademark and other intellectual property laws. All rights are reserved. No part of this manual may be reproduced by any mechanical, electronic or other means, in any form, without prior written permission of Runco.

The trademarks reproduced in this Runco Owner's Manual and used on the Runco Products are either owned by Runco or are licensed by Runco. You may not reproduce or use the trademarks without the prior written consent of Runco.

Runco Products are manufactured under one or more of the following patents: US. Patent 6755540 and Other Patents Pending.

# Important Safety Instructions

Thank you for your purchase of this quality Runco video product! For the best performance, please read this manual carefully as it is your guide through the menus and operation.

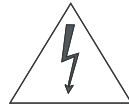
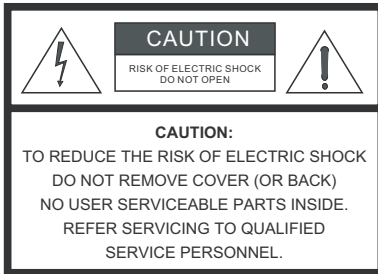

## WARNING

This symbol is intended to alert the user to the presence of uninsulated “dangerous voltage” within the product’s enclosure that may be of sufficient magnitude to constitute a risk of electric shock.



This symbol is intended to alert the user to the presence of important operating and maintenance (servicing) instructions in the literature accompanying the appliance.

1. Read these instructions.
2. Keep these instructions.
3. Heed all warnings.
4. Follow all instructions.
5. Do not use this apparatus near water.
6. Clean only with a dry cloth.
7. Do not block any of the ventilation openings. Install in accordance with the manufacturer’s instructions.
8. Do not install near any heat sources such as radiators, heat registers, stoves, or other apparatus (including amplifiers) that produce heat.
9. Do not defeat the safety purpose of the polarized or grounding type plug. A polarized plug has two blades with one wider than the other. A grounding type plug has two blades and a third grounding prong. The wide blade or the third prong is provided for your safety. When the provided plug does not fit into your outlet, consult an electrician for the replacement of the obsolete outlet.
10. Protect the power cord from being walked on or pinched particularly at plugs, convenience receptacles and the point where they exit from the apparatus.
11. Only use the attachments/accessories specified by the manufacturer.
12. Use only with a cart, stand, tripod, bracket or table specified by the manufacturer or sold with the apparatus. When a cart is used, use caution when moving the cart/apparatus to avoid injury from tip-over.
13. Unplug this apparatus during lightning storms or when unused for long periods of time.
14. Refer all servicing to qualified service personnel. Servicing is required when the apparatus has been damaged in any way, such as power supply cord or plug is damaged, liquid has been spilled or objects have fallen into the apparatus, the apparatus has been exposed to rain or moisture, does not operate normally, or has been dropped.
15. The +12V trigger only outputs 12Vdc signal for triggering. Do not connect to any other power input or output. This could cause damage to this unit.
16. Keep the packing material in case the equipment should ever need to be shipped.
17. The lamp becomes extremely hot during operation. Allow the projector to cool down for approximately 45 minutes prior to removing the lamp assembly for replacement.
18. Do not operate lamps beyond the rated lamp life. Excessive operation of lamps beyond rated life could cause them to explode in rare occasions.
19. Never look directly into the lens when the lamp is on.



---

# Compliance Information

---

## DECLARATION OF CONFORMITY:

Manufacturer's Name: Runco International, LLC

Manufacturer's Address: 1195 NW Compton Drive, Beaverton, OR 97006-1992

hereby declares that the Products' Model Numbers:

SC-50d, SC-50d/CineWide with AutoScope, SC-60d and SC-60d/CineWide with AutoScope

conform with the provisions of:

Council Directive 2004/108/EC on Electromagnetic Compatibility;

EN 55022 "Limits and methods of measurements of radio interference characteristics of information technology equipment" 1998;

EN 55024 "Limits and methods of measurements of immunity characteristics of information technology equipment" 1998;

Including:

- EN 61000-4-2 "Electromagnetic compatibility (EMC) Part 4: Testing and measurement techniques Section 2: Electrostatic discharge immunity test"
- EN 61000-4-3 "Electromagnetic compatibility (EMC) Part 4: Testing and measurement techniques Section 3: Radiated, Radio-Frequency, Electromagnetic Field Immunity Test"
- EN 61000-4-4 "Electromagnetic compatibility (EMC) Part 4: Testing and measurement techniques Section 4: Electrical fast transient/burst immunity test"
- EN 61000-4-5 "Electromagnetic compatibility (EMC) Part 4: Testing and measurement techniques Section 5: Surge immunity test"
- EN 61000-4-6 "Electromagnetic compatibility (EMC) Part 4: Testing and measurement techniques Section 6: Conducted disturbances induced by radio-frequency fields immunity test"
- EN 61000-4-8 "Electromagnetic compatibility (EMC) Part 4: Testing and measurement techniques Section 8: Conducted disturbances induced by power frequency magnetic fields immunity test"
- EN 61000-4-11 "Electromagnetic compatibility (EMC) Part 4: Testing and measurement techniques Section 11: Voltage dips, short interruptions and voltage variations immunity tests"

And:

- EN 61000-3-2 "Electromagnetic compatibility (EMC) Part 3, Section 2: Limits for harmonic current emissions (equipment input current up to and including 16 A per phase)" 2000;
- EN 61000-3-3 "Electromagnetic compatibility (EMC) Part 3, Section 3: Limitations of voltage changes, voltage fluctuations and flicker in public low-voltage supply systems, for equipment with rated current up to and including 16 A and not subject to conditional connection" 1995;

Council Directive 2006/95/EC and amended by M1 and C1 on Low Voltage Equipment Safety;

EN 60950 "Safety of information technology equipment, including electrical business equipment"

The Technical Construction file required by this Directive is maintained at the corporate headquarters of Runco International, LLC, located at 1195 NW Compton Drive, Beaverton, OR 97006-1992.

Date of Declaration: March 2011



## FCC PART 15:

NOTE: This equipment has been tested and found to comply with the limits for a Class A digital device, pursuant to Part 15 of the FCC Rules. These limits are designed to provide reasonable protection against harmful interference in a residential installation.

This equipment generates, uses and can radiate radio frequency energy and, if not installed and used in accordance with the instructions, may cause harmful interference to radio communications. However, there is no guarantee that interference will not occur in a particular installation. If this equipment does cause harmful interference to radio or television reception, which can be determined by turning the equipment off and on, the user is encouraged to try to correct the interference by one or more of the following measures:

- Reorient or relocate the receiving antenna.
- Increase the separation between the equipment and receiver.
- Connect the equipment into an outlet on a circuit different from that to which the receiver is connected.
- Consult the dealer or an experienced radio/TV technician for help.

## INDUSTRY CANADA (ICES-003):

This Class A digital apparatus complies with Canadian ICES-003.

Cet appareil numérique de la classe A est conforme à la norme NMB-003 du Canada.

## PRODUCT DISPOSAL:

The Product contains small amounts of tin, lead and/or mercury. Disposal of these materials may be regulated due to environmental considerations.

## IMPORTANT RECYCLE INSTRUCTIONS



Lamp(s) inside this product contain mercury. This product may contain other electronic waste that can be hazardous if not disposed of properly. Recycle or dispose in accordance with local, state, or federal Laws.

For more information, contact the Electronic Industries Alliance at [WWW.EIAE.ORG](http://WWW.EIAE.ORG).

For lamp specific disposal information check [WWW.LAMPRECYCLE.ORG](http://WWW.LAMPRECYCLE.ORG).

## DISPOSAL OF OLD ELECTRICAL AND ELECTRONIC EQUIPMENT (Applicable throughout the European Union and other European countries with separate collection programs)



This symbol found on your product or on its packaging, indicates that this product should not be treated as household waste when you wish to dispose of it. Instead, it should be handed over to an applicable collection point for the recycling of electrical and electronic equipment. By ensuring this product is disposed of correctly, you will help prevent potential negative consequences to the environment and human health, which could otherwise be caused by inappropriate disposal of this product. The recycling of materials will help to conserve natural resources. This symbol is only valid in the European Union. If you wish to discard this product, please contact your local authorities or dealer and ask for the correct method of disposal.

---

## Notes:

# Table of Contents

<b>RuncoCare™ Standard Two Year Limited Warranty .....</b>	<b>iii</b>
<b>Important Safety Instructions .....</b>	<b>vii</b>
<b>Compliance Information .....</b>	<b>viii</b>
<b>1. Introduction .....</b>	<b>1</b>
About This Manual .....	1
Target Audience .....	1
If You Have Comments About This Manual.....	1
Textual and Graphic Conventions .....	1
Using This Manual .....	2
Description, Features and Benefits .....	3
Key Features and Benefits .....	4
Parts List .....	4
<b>2. Controls and Functions .....</b>	<b>5</b>
SC-50d/SC-60d at a Glance .....	5
SC-50d/SC-60d Input Panel .....	6
DHD Controller Front Panel .....	8
DHD Controller Rear Panel .....	9
SC-50d/SC-60d Remote Control Units .....	11
DHD Controller/SC-50d/SC-60d Remote Control Unit.....	11
Setup Remote Control .....	14
<b>3. Installation .....</b>	<b>15</b>
Remote Control .....	15
Notes on Batteries .....	15
Notes on Remote Control Operation.....	16
Quick Setup .....	16

---

Installation Considerations .....	17
Installation Type .....	17
Ambient Light .....	17
Throw Distance.....	18
Vertical and Horizontal Position.....	19
Vertical and Horizontal Lens Shift.....	19
Folded Optics .....	22
Audio/Video Synchronization Issues.....	23
Ventilation.....	24
Other Considerations.....	24
Installing the Primary Projection Lens .....	25
Installing the Optional CineWide with AutoScope Lens Motor .....	26
Remove Projector Front Feet .....	26
Install Anamorphic Lens Motor.....	26
Mounting the SC-50d/SC-60d .....	27
Floor Mounting (Upright) .....	27
Ceiling Mounting (Inverted).....	27
Installing the Projector in an Enclosure.....	27
Adjusting the Projection Angle .....	28
Connections to the SC-50d/SC-60d and DHD Controller .....	29
Connecting the DHD Controller to the SC-50d/SC-60d .....	29
Connecting Source Components to the DHD Controller .....	31
Connecting an Audio Processor or Secondary Display Device to the DHD Controller (Optional).....	36
Additional Connections to the DHD Controller (Optional).....	37
Connecting to AC Power .....	40
Turning on the Power .....	41
Primary Lens Adjustments: Focus, Zoom and Position .....	41
Adjusting the Picture Orientation .....	42
Adjusting the Image Geometry .....	43
Installing and Adjusting the CineWide Anamorphic Lens .....	45
Attach Lens Mounting Assembly to Lens Motor Carriage Plate .....	46
Configure Lens Motor Trigger (CineWide with AutoScope) .....	47
Adjust the Anamorphic Lens .....	47
Verify Proper Image Alignment with Anamorphic Lens .....	50
Working With the Lamp .....	50

---

<b>4. Operation .....</b>	<b>51</b>
Using the On-Screen Menus .....	51
Main Menu.....	53
Input Source.....	53
Aspect Ratio.....	53
Picture.....	56
Input Position.....	60
Memory Presets .....	62
Sleep Timer .....	63
Information .....	64
Calibration .....	65
Service .....	70
<b>5. Maintenance and Troubleshooting .....</b>	<b>81</b>
Lamp Replacement .....	81
Troubleshooting Tips .....	83
<b>6. External Control .....</b>	<b>85</b>
Serial Communications .....	85
RS-232 Connection and Port Configuration.....	85
Serial Command Syntax .....	85
Using Discrete IR Codes .....	90
IR Command Protocol.....	90
IR Command List.....	92
Using HDMI CEC Messages .....	94
CEC Command List.....	94
<b>7. Specifications .....</b>	<b>97</b>
SC-50d/SC-60d Projector Specifications .....	97
DHD Controller Specifications .....	99
SC-50d/SC-60d Dimensions .....	101
SC-50d/SC-60d Dimensions with CineWide with AutoScope Assembly .....	102
Supported Timings .....	103

**Notes:**

# List of Figures

2-1. SC-50d/SC-60d Top/Rear/Front View.....	5
2-2. SC-50d/SC-60d Input Panel .....	6
2-3. DHD Controller Front Panel .....	8
2-4. DHD Controller Rear Panel .....	9
2-5. DHD Controller/SC-50d/SC-60d Remote Control.....	11
2-6. Setup Remote Control for SC-50d/SC-60d .....	14
3-1. Estimating Throw Distance .....	18
3-2. Projector Placement .....	19
3-3. Vertical Lens Shift (EXAMPLE ONLY) .....	19
3-4. Horizontal Lens Shift (EXAMPLE ONLY).....	20
3-5. Folded Optics.....	22
3-6. Ventilation Requirements for Enclosure Mounting .....	24
3-7. Attaching the AutoScope Lens Motor to the Projector .....	26
3-8. Mounting Angle Ranges (Front-to-Back and Side-to-Side).....	28
3-9. Connecting the SC-50d/SC-60d to the DHD Controller.....	29
3-10. RS-232 Connection from the DHD Controller to the SC-50d/SC-60d.....	30
3-11. HDMI Source Connections .....	31
3-12. Component Video Source Connections.....	32
3-13. RGBHV Source Connections.....	33
3-14. SCART RGBS Source Connections.....	34
3-15. Composite Video Source Connections .....	35
3-16. Audio Processor Connection to DHD Controller .....	36
3-17. RS-232 Control System Connection to DHD Controller .....	37
3-18. Connecting 12-volt Trigger Outputs.....	38
3-19. External IR Receiver Connection.....	39
3-20. Ethernet Network Connection to DHD Controller .....	40
3-21. Keystone and Pincushion Distortion .....	43
3-22. Image Alignment Controls .....	44
3-23. Anamorphic Lens Mounting Assembly - Exploded View .....	45
3-24. Attaching the Anamorphic Lens to the Lens Ring .....	46
4-1. SC-50d/SC-60d OSD Menu Structure .....	51
4-2. Typical PLUGE Pattern for Adjusting Brightness .....	56
4-3. Typical Gray Bar Pattern for Adjusting Contrast.....	57
4-4. Typical Color Bar Pattern for Adjusting Color Saturation and Tint.....	58

4-5. Typical Test Pattern for Adjusting Sharpness .....	60
4-6. Overscan Modes .....	61
4-7. CIE 1931 Chromaticity Diagram .....	67
5-1. Opening the Lamp Door .....	81
6-1. RC5 Message Format .....	91
7-1. SC-50d/SC-60d Dimensions .....	101
7-2. SC-50d/CineWide with AutoScope and SC-60d/CineWide with AutoScope Dimensions .....	102



# 1. Introduction

This Owner's Manual describes how to install, set up and operate the Runco Signature Cinema™ Series SC-50d/SC-60d Private Cinema Projector and DHD Controller.

Throughout this manual, the Runco Signature Cinema™ Series SC-50d/SC-60d Private Cinema Projector and DHD Controller is referred to as the "SC-50d/SC-60d."

Runco has prepared this manual to help installation personnel and end users get the most out of the SC-50d/SC-60d.

Runco has made every effort to ensure that this manual is accurate as of the date it was printed. However, because of ongoing product improvements and customer feedback, it may require updating from time to time. You can always find the latest version of this and other Runco product manuals on-line, at [www.Runco.com](http://www.Runco.com).

Runco welcomes your comments about this manual. Send them to [support@Runco.com](mailto:support@Runco.com).

**Text Conventions:** The following conventions are used in this manual, in order to clarify the information and instructions provided:

- Remote and built-in keypad button identifiers are set in upper-case bold type; for example, "Press **EXIT** to return to the previous menu."
- Computer input (commands you type) and output (responses that appear on-screen) is shown in monospace (fixed-width) type; for example: "To change the aspect ratio to Letterbox, type LETTERBOX **<Enter>**."
- All keys with functional names are initial-capped, set in bold type and enclosed in angle brackets. These keys are the following: **<Enter>**, **<Spacebar>**, **<Control>**, **<Esc>** and **<Tab>**.
- **<Enter>** indicates that you may press either the RETURN or ENTER key on your keyboard if it has both keys.

In addition to these conventions, underlining, boldface and/or italics are occasionally used to highlight important information, as in this example:



## Note

*A carriage return **must** be used after each command or string.*

## 1.1 About This Manual

### ◀ Target Audience

### ◀ If You Have Comments About This Manual...

### ◀ Textual and Graphic Conventions

**Graphic Conventions:** These symbols appear in numerous places throughout the manual, to emphasize points that you must keep in mind to avoid problems with your equipment or injury:



**Tip**

*TIPS highlight time-saving short cuts and helpful guidelines for using certain features.*



**Note**

*NOTES emphasize text with unusual importance or special significance. They also provide supplemental information.*



**Caution**

*CAUTIONS alert users that a given action or omitted action can degrade performance or cause a malfunction.*



**WARNING**

*WARNINGS appear when a given action or omitted action can result in damage to the equipment, or possible non-fatal injury to the user.*



**DANGER!**

*DANGER appears when a given action can cause severe injury or death.*

## 1.2 Using This Manual

Use the following table to locate the specific information you need in this manual.

If you need...	... Turn to page:
Information about obtaining service	iv
General information about the Signature Cinema™ Series SC-50d/SC-60d Private Cinema Projector and DHD Controller	3
Installation instructions	15
First-time configuration instructions	41
Advanced configuration instructions	65
Troubleshooting tips	83
Specifications for the Signature Cinema™ Series SC-50d/SC-60d Private Cinema Projector and DHD Controller	97

---

Offering the best in high-end luxury projection, the new Signature Cinema™ Series SC-50d/SC-60d Private Cinema Projector and DHD Controller expands Runco's most prestigious line of custom-built personal cinema projectors. The SC-50d and SC-60d join Runco's legendary SC-1 and offer the best cinematic experience available for the most sophisticated private cinemas.

The Signature Cinema™ Series SC-50d/SC-60d Private Cinema Projector and DHD Controller offers exceptional performance with a state-of-the-art product that provides an extraordinary cinematic experience. The Signature Cinema experience surpasses even the most renowned public theaters because the product and room are custom-built with the finest components to exactly match an owner's specifications.

Combined with the unique and flexible engine design, the SC-50d/SC-60d provides better, richer color performance for pristine color accuracy. These benefits combine into a brilliant image that provides a spectacular color gamut and contrast, as well as unmatched color brightness, even on the largest screen sizes.

For unparalleled reproduction of Hollywood's 2.35:1 CinemaScope standard, the SC-50d/SC-60d is available with Runco's legendary CineWide™ with AutoScope™ technology. Selecting from multiple lens options that allow the flexibility for seamless integration into the most sophisticated personal cinemas, each SC-50d/SC-60d projector is custom-built to suit the exact requirements specified for every client. The SC-50d/SC-60d features 1080p HD native resolution 3-chip system for the finest projection image and 16:9 native aspect ratio to match all digital programming including seamlessly switching aspect ratios for all media, including broadcast, film, sports and gaming.

**Note**

*CineWide requires the use of a 2.35:1 (or similar aspect ratio), "superwide" format screen.*

---

## 1.3 Description, Features and Benefits

- Key Features and Benefits** ➤ The SC-50d/SC-60d offers these key features and benefits:
- Cinema-quality color with the most accurate and exceptionally broad color gamuts
  - Multiple lens options including compatibility with Runco's award-winning CineWide™ with AutoScope®
  - Ships with Runco's DHD Controller featuring ViVix™ video processing for exceptional scaling, analog to digital signal conversion, and control via IR or RS-232
  - Bundled with two years of Runco PremierCare™ service program providing on-site calibration and two years of ongoing support from Runco
  - Native Resolution: 1920 x 1080 (16:9 Native Aspect Ratio)
  - DLP system using three, high-performance Digital Micromirror Device (DMD) chips

**Parts List** ➤ Your SC-50d/SC-60d is shipped with the following items. If any items are missing or damaged, please contact your Runco dealer or Runco Customer Service at (800) 23RUNCO.

- Signature Cinema™ Series SC-50d/SC-60d Private Cinema Projector and DHD Controller
- DHD Controller Remote Control Unit and batteries
- Setup Remote Control Unit and batteries
- AC power cord for projector (with ferrite sleeve, rated at 15 amps)
- AC power cord for DHD Controller
- RJ-11 Telephone Cable, 50 feet (15.24 meters)
- Serial Port Adapter, RJ-11 Female to DB-9 Male
- Adapter, DVI-I male-to-HDMI female
- Rack-mounting brackets and hardware for the DHD Controller
- Signature Cinema™ SC-50d/SC-60d Quick Setup Guide

**Optional Accessories:**

- CineWide™ with AutoScope™ system (secondary anamorphic lens and motorized mount)
- Ceiling mount kit (part number 956-0302-00)

## 2. Controls and Functions

Figure 2-1 shows the key SC-50d/SC-60d components.

### 2.1 SC-50d/SC-60d at a Glance

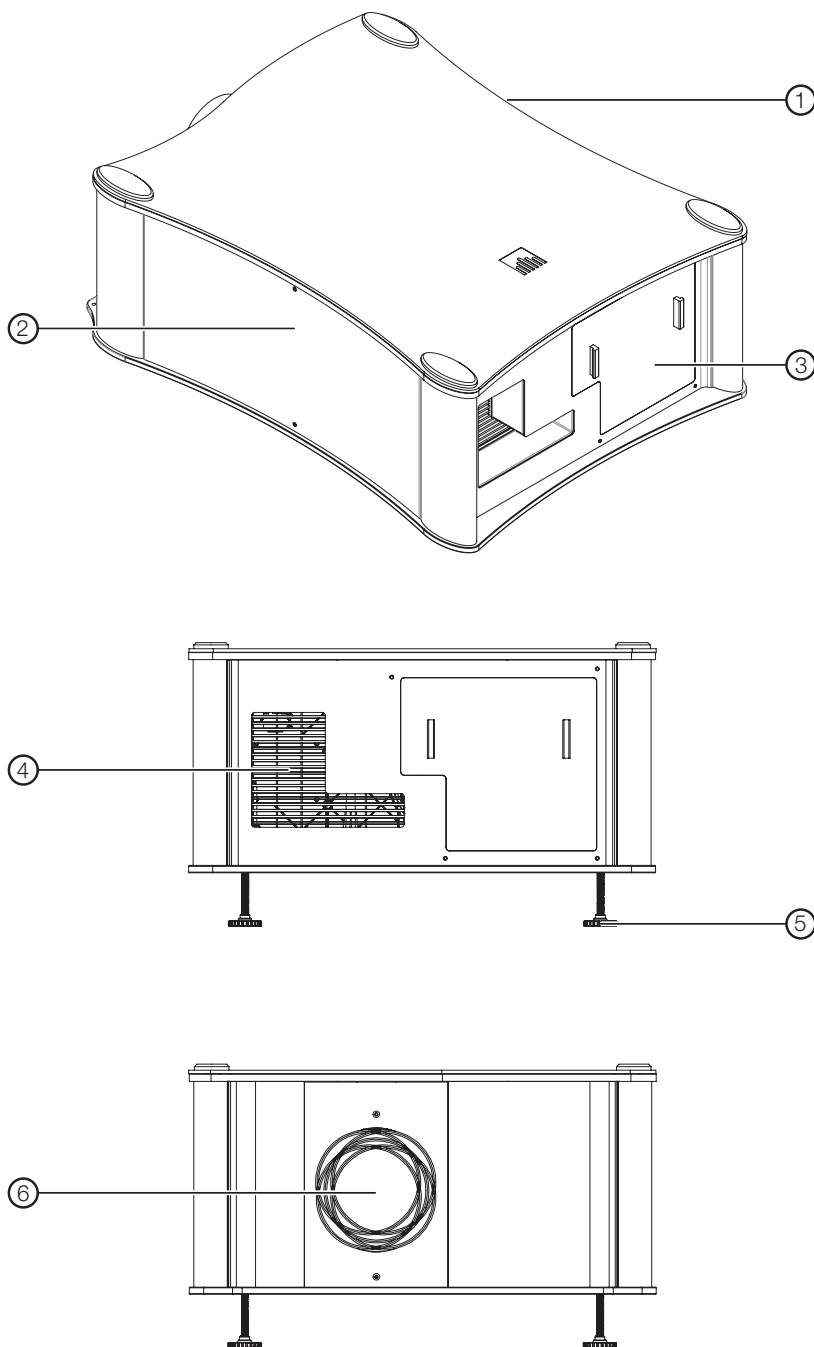

**Figure 2-1. SC-50d/SC-60d Top/Rear/Front View**

1. **RIGHT (INTAKE) SIDE PANEL**  
The right side panel is perforated to allow cool air to enter the projector.
2. **LEFT (EXHAUST) SIDE PANEL**  
The left side panel is perforated to allow warm air to exit the projector. Removing this panel provides access to the lamp.
3. **INPUT PANEL COVER**  
Removing this panel provides access to the projector input panel. For more information, refer to **SC-50d/SC-60d Input Panel** on page 6.
4. **REAR EXHAUST VENT**  
Warm air exits the projector through this vent. Ensure that it is not obstructed in any way.
5. **ADJUSTABLE FEET (4)**  
Located on the underside of the projector are four adjustable feet. Raise or lower these feet when positioning the projector to ensure it is level on all sides so the displayed image will appear rectangular without any keystone.
6. **PROJECTION LENS**

## 2.2 SC-50d/SC-60d Input Panel

Figure 2-2 shows the SC-50d/SC-60d rear input panel.

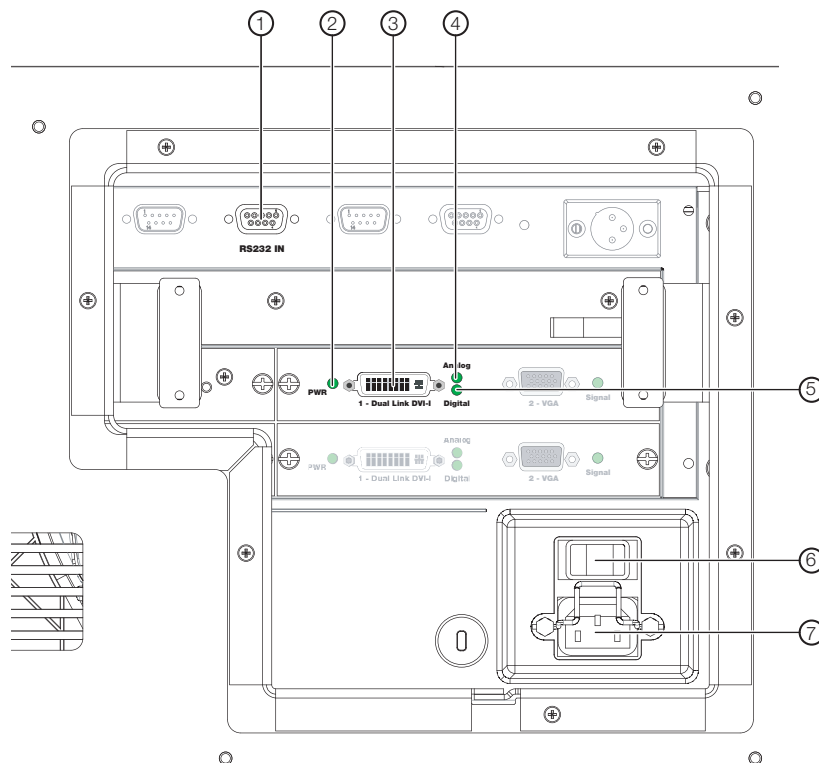

Figure 2-2. SC-50d/SC-60d Input Panel

1. **RS232 IN**  
Connect the RS-232 output from the DHD Controller here, using the provided RJ11-to-DB9 adapter and communication cable.
2. **PWR LED**  
Lights green to indicate that power is applied and the module is initialized. During normal operation, always on.
3. **1 - Dual-Link DVI-I Input (Slot 2)**  
HDCP-compliant digital video input. Connect the HDMI output from the DHD Controller to this input (see Figure 2-4).
4. **Analog LED**  
Lights briefly when the projector is powered up (self-test). During normal operation, always off.
5. **Digital LED**  
Lights green to indicate that a valid digital signal from the DHD Controller is present.
6. **MAIN POWER SWITCH**  
Disconnects or applies power to the SC-50d/SC-60d.
7. **POWER INPUT (100 to 240 VAC)**  
Connect the projector to power here.

**WARNING**

**Use ONLY the AC power cord shipped with the SC-50d/SC-60d for this purpose (the one with the ferrite sleeve). Doing otherwise creates a fire hazard risk.**

## 2.3 DHD Controller Front Panel

Figure 2-3 shows the controls and indicators on the DHD Controller front panel; the paragraphs that follow describe them.

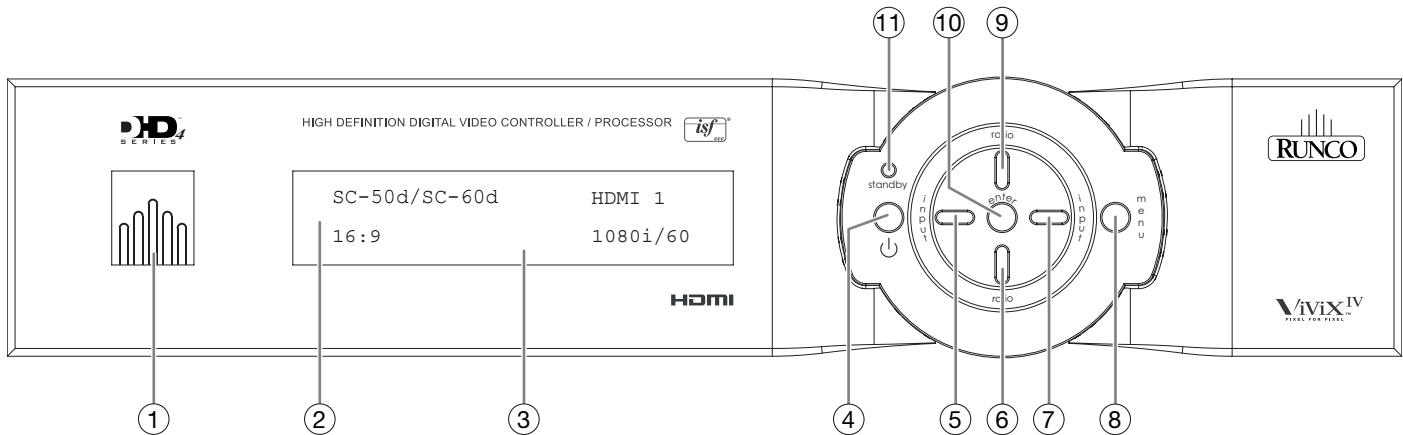

**Figure 2-3. DHD Controller Front Panel**

1. **RUNCO ICON**  
Lights blue to indicate that the controller is on or powering up.
2. **IR SENSOR**  
Receives IR commands from the remote control.
3. **VACUUM FLUORESCENT DISPLAY**  
Can be used instead of the On-Screen Display (OSD). Displays currently-selected menu or – if no menu is selected – the connected display device model, current source, input resolution and aspect ratio.
4. **ON/STANDBY BUTTON**  
Press once to toggle from standby mode to on mode. Press it again to return to standby mode. For a discrete on or off command, you can use the direct access buttons on the remote control.
5. **LEFT BUTTON**  
Used to direct-select inputs or move the OSD menu cursor to the left. When no menu is present on-screen, the **LEFT** button toggles through the different sources, in this order:  
HDMI 4 - HDMI 3 - HDMI 2 - HDMI 1 - SCART - HD 2 - HD 1 - Component - Composite 3 - Composite 2 - Composite 1
6. **DOWN BUTTON**  
Use to direct-select aspect ratios or move the OSD menu cursor down. When no menu is present on-screen, this button toggles through the different aspect ratios, in this order:  
16:9 - 4:3 - Letterbox - VirtualWide - Cinema - Virtual Cinema - Native



**7. RIGHT BUTTON**

Used to direct-select inputs or move the OSD menu cursor to the right. When no menus are present on-screen, the **RIGHT** button toggles through the different sources, in this order:

Composite 1 - Composite 2 - Composite 3 - Component - HD 1 - HD 2 - SCART - HDMI 1 - HDMI 2 - HDMI 3 - HDMI 4

**8. MENU BUTTON**

Press the **MENU** button to bring up the main menu, or to exit the current menu and return to the previous one.

**9. UP BUTTON**

Use to direct-select aspect ratios or move the OSD menu cursor up. When no menus are present on-screen, the **UP** button toggles through aspect ratios in the following order:

Native - Virtual Cinema - Cinema - VirtualWide - Letterbox - 4:3 - 16:9

**10. ENTER BUTTON**

When an item is highlighted on the OSD, the **ENTER** button selects the item.

**11. STANDBY LED**

Lights amber when the DHD Controller is in standby mode; otherwise it is off.

Figure 2-4 shows the rear connector panel on the DHD Controller.

## 2.4 DHD Controller Rear Panel

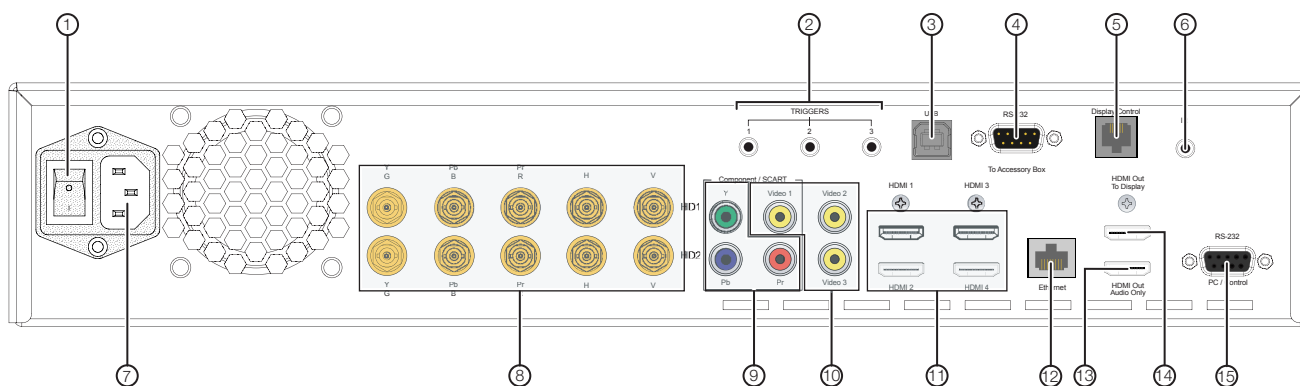

**Figure 2-4. DHD Controller Rear Panel**

**1. MAIN POWER SWITCH**

Disconnects or applies power to the DHD Controller.

**2. TRIGGERS**

Connection for up to three (3), 12-volt trigger-controlled devices such as retractable screens or screen masks. Output current is limited to 250 milliamperes (mA).

**3. USB**

A standard, USB Series "B" connection to a personal computer, for performing software upgrades and other service procedures.

4. **RS-232 (To Accessory Box)**  
A male, 9-pin D-sub connector for interfacing with external equipment. (For future use.)
  5. **Display Control**  
Connect this to the RS-232 input on the SC-50d/SC-60d projector.
  6. **IR**  
Wired input from a Niles- or Xantech-compatible, infrared (IR) repeater system. It is a 3.5-mm, mini phono jack, wired as follows:  
Ring = No connection  
Tip = IR Input  
Sleeve = Ground
  7. **POWER INPUT (100 to 240 VAC)**  
Connect the DHD Controller to power here.
  8. **HD1 / HD2 (5 x Analog BNCs)**  
Two inputs (five BNCs per input) for connecting standard-definition (SD = 480i/576i), enhanced-definition (ED = 480p/576p) or high-definition (HD = 720p/1080i/1080p) component video sources, or RGBHV sources such as personal computers.
  9. **Component / SCART (3 x RCA connectors)**  
SD/HD input for connecting SDTV, EDTV or HDTV component video sources. Also provides RGB input for SCART RGBS sources.
  10. **Video 1 / Video 2 / Video 3**  
Standard, composite video inputs for connecting a VCR, camcorder or other composite video source. The Video 1 input also provides composite sync input for SCART RGBS sources.
  11. **HDMI 1 / HDMI 2 / HDMI 3 / HDMI 4 (Digital)**  
HDCP-compliant digital video inputs for connecting an HDMI or DVI source.
  12. **Ethernet**  
A female RJ-45 connector for wired network communications.
  13. **HDMI Out (Audio Only)**  
Connect this output to an audio control system to pass through HDMI audio.
-  **Note** *The DHD Controller does not transmit HDMI CEC control messages from the "HDMI Audio Out" connector.*
14. **HDMI Out (To Display)**  
Connect this to the **DHD Input** on the SC-50d/SC-60d (see Figure 2-2).
  15. **RS-232 (PC / Control)**  
A female, 9-pin D-sub connector for interfacing with a PC or automation/control system.

The SC-50d/SC-60d ships with two remote control units:

- A standard Runco DHD Controller remote control unit; and
- A “setup” remote control unit for making lens adjustments.

**Only the setup remote control can be used to perform lens shift, zoom and focus adjustments.** For this reason, you must use it to complete the initial SC-50d/SC-60d installation and setup. After you have completed the installation, only the standard DHD Controller remote control is needed to access all projector and controller functions.

Figure 2-5 shows the SC-50d/SC-60d remote control, and the paragraphs that follow describe its functionality.

## 2.5 SC-50d/SC-60d Remote Control Units

### ◀ DHD Controller/ SC-50d/SC-60d Remote Control Unit

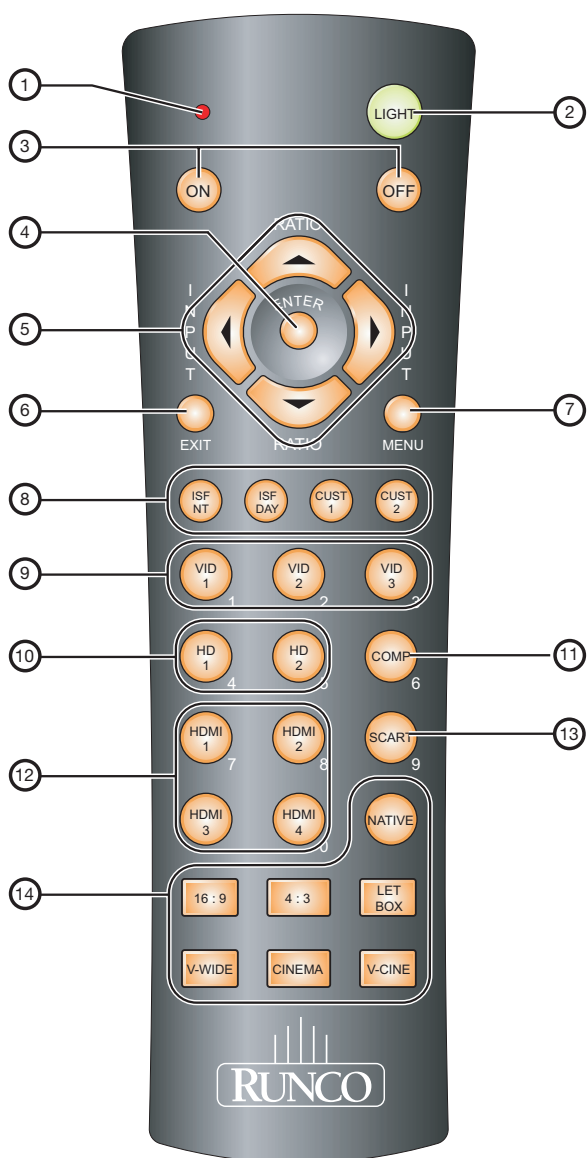

**Figure 2-5. DHD Controller/SC-50d/SC-60d Remote Control**

1. **IR OUTPUT INDICATOR**  
Lights when a button is pressed to indicate that an IR signal is being transmitted.
2. **LIGHT**  
Press to illuminate the buttons.
3. **ON / OFF**  
Press to turn the DHD Controller and projector on or off.
4. **ENTER**  
Press to select a highlighted menu item or confirm a changed setting.
5. **Cursor Buttons (▲, ◀, ▼, ▶)**  
Use these buttons to select items or settings, adjust settings or switch display patterns.

When no menu is present on-screen, the **UP** and **DOWN** buttons toggle through the available aspect ratios, in this order:

**UP** Button = Native - Virtual Cinema - Cinema - VirtualWide - Letterbox - 4:3 - 16:9

**DOWN** Button = 16:9 - 4:3 - Letterbox - VirtualWide - Cinema - Virtual Cinema - Native



**Note**

*For more information about aspect ratios, refer to Table 4-1.*

Likewise, the **LEFT** and **RIGHT** buttons toggle through the different source inputs, in this order:

**LEFT** Button = HDMI 4 - HDMI 3 - HDMI 2 - HDMI 1 - SCART - HD 2 - HD 1 - Component - Composite 3 - Composite 2 - Composite 1

**RIGHT** Button = Composite 1 - Composite 2 - Composite 3 - Component - HD 1 - HD 2 - SCART - HDMI 1 - HDMI 2 - HDMI 3 - HDMI 4

6. **EXIT**  
Press this button to exit the current menu and return to the previous one.
7. **MENU**  
Press this button to access the OSD controls, or to exit the current menu and return to the previous one.
8. **Memory Preset Buttons:**
  - ISF NIGHT**  
Press to recall settings for the current input from the “ISF Night” memory preset.
  - ISF DAY**  
Press to recall settings for the current input from the “ISF Day” memory preset.
  - CUST 1**  
Press to recall settings for the current input from the “Custom 1” memory preset.
  - CUST 2**  
Press to recall settings for the current input from the “Custom 2” memory preset.
9. **VID 1 (1) / VID 2 (2) / VID 3 (3)**  
Press to select a composite video input as the source or to enter the numeric character “1,” “2” or “3.”

---

**10. HD 1 (4) / HD 2 (5)**

Press to select a HD (RGBHV or YPbPr component) input or to enter the numeric character "4" or "5."

**11. COMP (Component) (6)**

Press to select the Component video input as the source or to enter the numeric character "6."

**12. HDMI 1 (7) / HDMI 2 (8) / HDMI 3 / HDMI 4 (0)**

Press to select an HDMI input as the source or to enter the numeric character "7," "8" or "0."

**13. SCART (9)**

Press to select the SCART video input as the source or to enter the numeric character "9."

**14. Aspect Ratio Selection Buttons**

Use these buttons to select an aspect ratio directly, as follows:

**NATIVE**

Displays the source signal in its native resolution, centered in the display area.

**16:9**

For viewing 16:9 DVDs or HDTV programs in their native aspect ratio.

**4:3**

Scales the input signal to fit 4:3 display mode in the center of the screen.

**LETBOX (Letterbox)**

For viewing non-anamorphic ("full-screen") DVDs on a 16:9 screen.

**V-WIDE (VirtualWide)**

Enlarges a 4:3 image horizontally in a non-linear fashion to fit 16:9 full screen display.

**CINEMA**

For viewing 2.35:1 source material.

**V-CINE**

Selects the Virtual Cinema aspect ratio, used for viewing 16:9 source material on a 2.35:1 screen.

**Setup Remote Control** ➤ The setup remote control unit furnished with the SC-50d/SC-60d gives you access to the motorized lens controls (position, focus and zoom).

Figure 2-6 shows the setup remote control, and the paragraphs that follow describe its functionality.

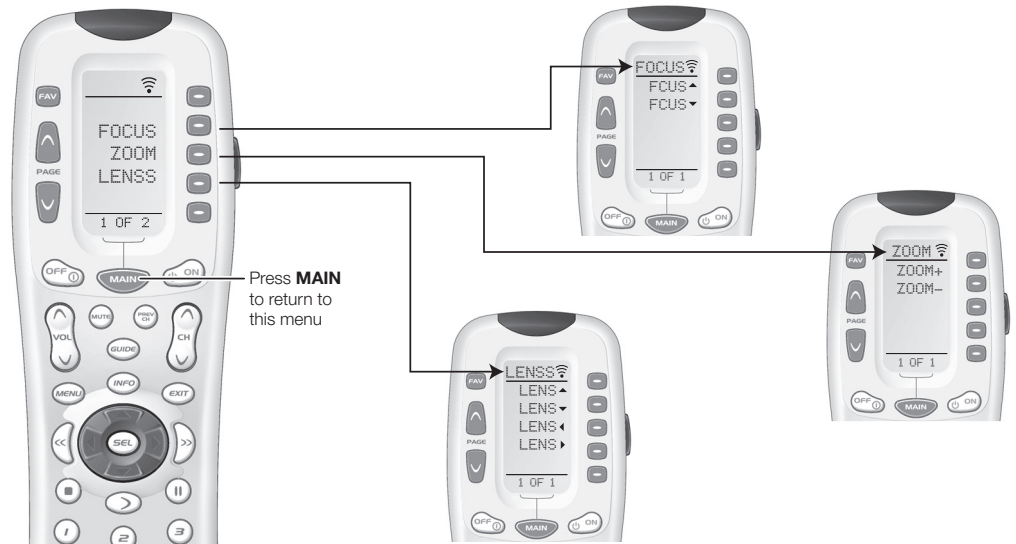

**Figure 2-6. Setup Remote Control for SC-50d/SC-60d**

- **FOCUS Button**  
Press to access the lens focus controls.
- **ZOOM Button**  
Press to access the lens zoom controls.
- **LENSS Button**  
Press to access the lens shift controls.
- **MAIN Button**  
Press to return to the Main lens control menu from the FOCUS, ZOOM or LENSS (lens shift) page.

## 3. Installation



### Note

Installation **must** be performed by a qualified custom video installation specialist.

To install batteries in the remote control:

1. Press down the tab on the cover and pull the cover in the direction of the arrow.
2. Insert the included batteries. Ensure that the polarities correctly match the  $\oplus$  and  $\ominus$  markings inside the battery compartment.
3. Insert the lower tab of the cover into the opening, and press down the cover until it clicks in place.

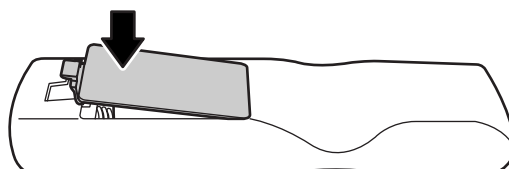
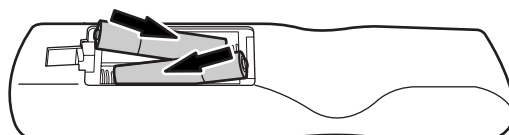
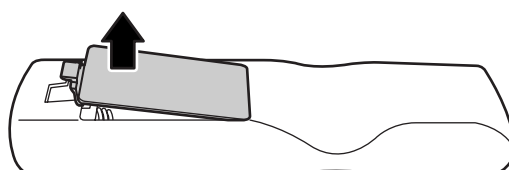

### 3.1 Remote Control

- Make sure that the battery polarities are correct when installing the batteries.
- Do not mix an old battery with a new one or different types of batteries.
- If you will not use the remote control for a long time, remove the batteries to avoid damage from battery leakage.
- Do not expose batteries to excessive heat such as from sunshine, fire or the like.

#### ◀ Notes on Batteries

**Notes on Remote Control Operation** ➤

- Make sure that there is nothing obstructing the infrared beam between the remote control and the IR receiver on the DHD Controller.
- If the effective range of the remote control decreases, or it stops working, replace the batteries with new ones.
- The remote control may fail to operate if the infrared remote sensor is exposed to bright sunlight or fluorescent lighting.
- Ambient conditions may possibly impede the operation of the remote control. If this happens, point the remote control at the DHD Controller, and repeat the operation.

**3.2 Quick Setup**

Table 3-1 gives a quick overview of the SC-50d/SC-60d installation process. The sections following this one provide detailed instructions.

**Table 3-1. Installation Overview**

Step	Procedure	For Details, Refer to page...
<b>1</b>	Choose a location for the projector	17
<b>2</b>	Install primary projection lens	25
<b>3</b>	Install CineWide with AutoScope lens motor (optional)	26, 38
<b>4</b>	Mount the projector	27
<b>5</b>	Connect the DHD Controller to the projector	29
<b>6</b>	Connect signal sources to the DHD Controller	31
<b>7</b>	Connect other external equipment to DHD Controller (optional): <ul style="list-style-type: none"> <li>• Audio processor or secondary display device</li> <li>• Control system interface (RS-232)</li> <li>• 12-volt trigger-activated equipment (AutoScope lens motor, retractable screens or screen masking etc.)</li> <li>• External IR repeater</li> <li>• Network hub, router or gateway (Ethernet)</li> </ul>	36
<b>8</b>	Apply power to the projector	40, 41
<b>9</b>	Adjust primary lens: projected image size (zoom), position (shift) and focus	19, 41
<b>10</b>	For rear-screen and/or ceiling-mount installations, select the proper picture orientation	42
<b>11</b>	Use Image Alignment controls to fine-tune image geometry	43
<b>12</b>	Install CineWide anamorphic lens (optional)	45
<b>13</b>	Adjust CineWide anamorphic lens: position, pitch (angle), geometry and focus	47
<b>14</b>	DHD Controller input calibration: adjust the following <b>for each DHD Controller input and display mode (resolution/frame rate)</b> ; save settings when finished: <ul style="list-style-type: none"> <li>• Aspect ratio</li> <li>• Brightness</li> <li>• Contrast</li> <li>• Color temperature and white balance</li> <li>• Color level</li> <li>• Tint</li> <li>• Input position</li> </ul>	53 through 68



Proper installation of your projector will ensure the quality of your display. Whether you are installing a projector temporarily or permanently, you should take the following into account to ensure your projector performs optimally.

Choose the installation type that best suits your needs: front or rear screen, floor mount or inverted mount. Table 3-2 compares these various installation methods.

**Table 3-2. Projector Installation Options**

Advantages	Considerations
<b>Front Screen, Floor Mount Installation</b>	
<ul style="list-style-type: none"> <li>• Easy to set up</li> <li>• Can be moved or changed quickly</li> <li>• Easy to access</li> </ul>	<ul style="list-style-type: none"> <li>• Shares floor space with audience</li> </ul>
<b>Front Screen, Inverted Mount (ceiling) Installation</b>	
<ul style="list-style-type: none"> <li>• Does not take up audience space</li> <li>• Projector is unobtrusive</li> <li>• Projector cannot be accidentally moved</li> </ul>	<ul style="list-style-type: none"> <li>• Installation is more permanent</li> <li>• Projector access is more difficult</li> </ul>
<b>Rear Screen, Floor Mount Installation</b>	
<ul style="list-style-type: none"> <li>• Projector is completely hidden</li> <li>• Projector is easily accessed</li> <li>• Usually good ambient light rejection</li> </ul>	<ul style="list-style-type: none"> <li>• Requires separate room</li> <li>• Installation cost is usually higher</li> </ul>
<b>Rear Screen, Inverted Mount (ceiling) Installation</b>	
<ul style="list-style-type: none"> <li>• Projector is completely hidden</li> <li>• Usually good ambient light rejection</li> </ul>	<ul style="list-style-type: none"> <li>• Requires separate room</li> <li>• Installation cost is usually higher</li> </ul>
<b>Rear Screen, Floor Mount with Mirror</b>	
<ul style="list-style-type: none"> <li>• Projector is completely hidden</li> <li>• Usually good ambient light rejection</li> <li>• Requires less space behind screen than other rear screen installations</li> </ul>	<ul style="list-style-type: none"> <li>• Requires separate room</li> <li>• Installation cost is usually higher</li> </ul>

In general, minimize or eliminate light sources directed at the screen. Contrast ratio in your images will be noticeably reduced if light directly strikes the screen, such as when a shaft of light from a window or floodlight falls on the image. Images may then appear washed out and less vibrant.

### 3.3 Installation Considerations

#### ◀ Installation Type

#### ◀ Ambient Light

**Throw Distance** ➤ Throw distance is the distance measured from the front of the projector to the screen. This is an important calculation in any projector installation as it determines whether or not you have enough room to install your projector with a desired screen size and if your image will be the right size for your screen.

You can quickly estimate the throw distance by taking the width of the screen and multiplying it by the lens throw ratio; see Figure 3-1. The result of this calculation tells you roughly how far back the projector should be positioned from the screen in order to project a focused image large enough to fill the screen.

**Estimating Throw Distance**

Throw Distance (TD) =  
Screen Width (w) x Lens Throw Ratio

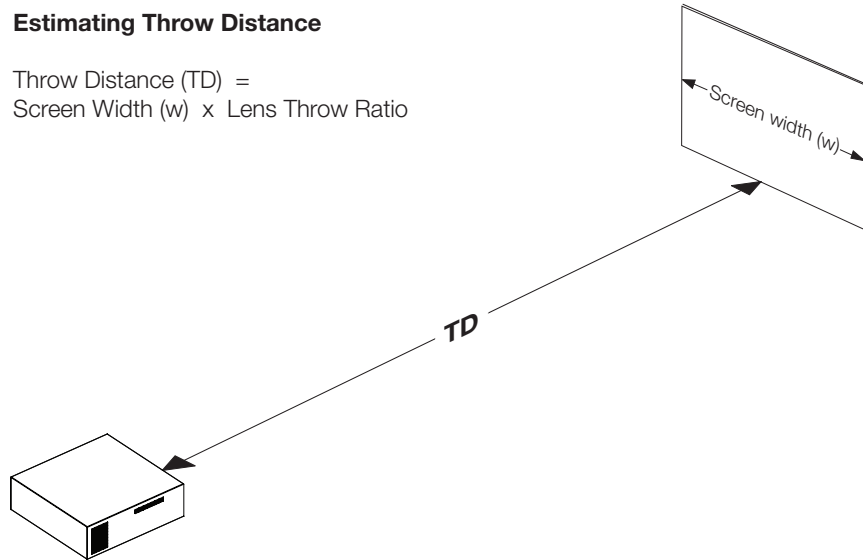

**Figure 3-1. Estimating Throw Distance**

Table 3-3 lists the available SC-50d/SC-60d lens options and their throw ratios.

**Table 3-3. SC-50d/SC-60d Lens Options and Throw Ratios (Note)**

Lens Option	Throw Ratio with Primary Lens Only	Throw Range in inches, with 120x67.5-inch (1.78:1) Screen		Throw Ratio with Primary Lens and Anamorphic Lens	Throw Range in inches, with 158.6x67.5-inch (2.35:1) Screen	
		Minimum	Maximum		Minimum	Maximum
Athena Uno	0.67 (Fixed)	For rear-screen installations only. Contact Runco Technical Support for more information.		Athena Uno cannot be used with an anamorphic lens.		
Athena Dos	1.39 - 1.85	166.80	222.00	1.20 - 1.39	190.36	220.50
Athena Tres	1.85 - 2.59	222.00	310.80	1.39 - 1.94	220.50	307.74
Athena Quatro	2.59 - 4.16	310.80	499.20	1.94 - 3.12	307.74	494.93
Athena Cinco	4.16 - 6.93	499.20	831.60	3.12 - 5.20	494.93	824.88

**Note:** Due to normal manufacturing variances, throw distance can vary by up to +/- 5 percent from these specifications.

Proper placement of the projector relative to the screen will yield a rectangular, perfectly-centered image that completely fills the screen.

◀ **Vertical and Horizontal Position**

Ideally, the projector should be positioned perpendicular to the screen and in such a way that the lens center is aligned with either the top or bottom edge of the screen area, and centered horizontally. See Figure 3-2.

**Ceiling Installation**

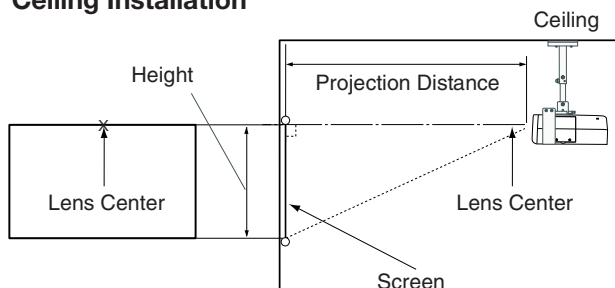

**Floor Installation**

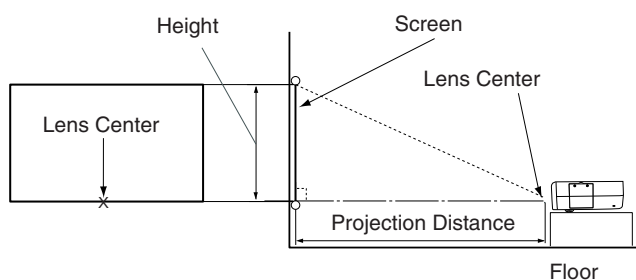

**Figure 3-2. Projector Placement**

You can use the lens shift controls to center the image on the screen. Lens shift is generally expressed as a percentage of the screen height or width, as shown in Figure 3-3 and Figure 3-4.

◀ **Vertical and Horizontal Lens Shift**

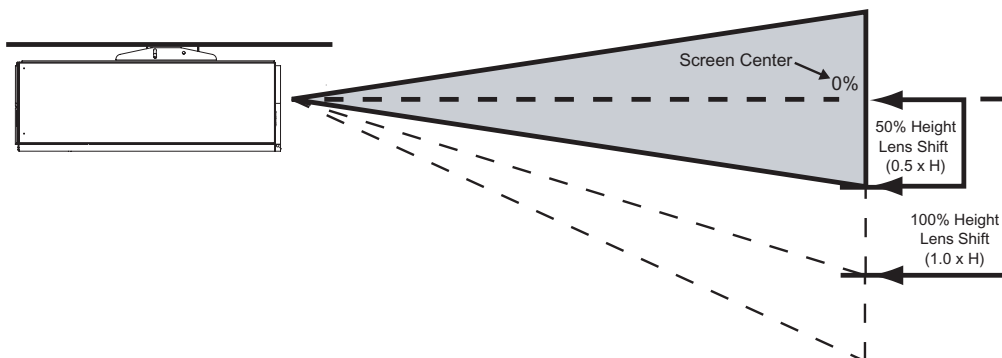

**Note:** This is a general example of lens shift. Lenses vary in their shift capabilities. **No particular lens or projector is used in this example.**

**Figure 3-3. Vertical Lens Shift (EXAMPLE ONLY)**

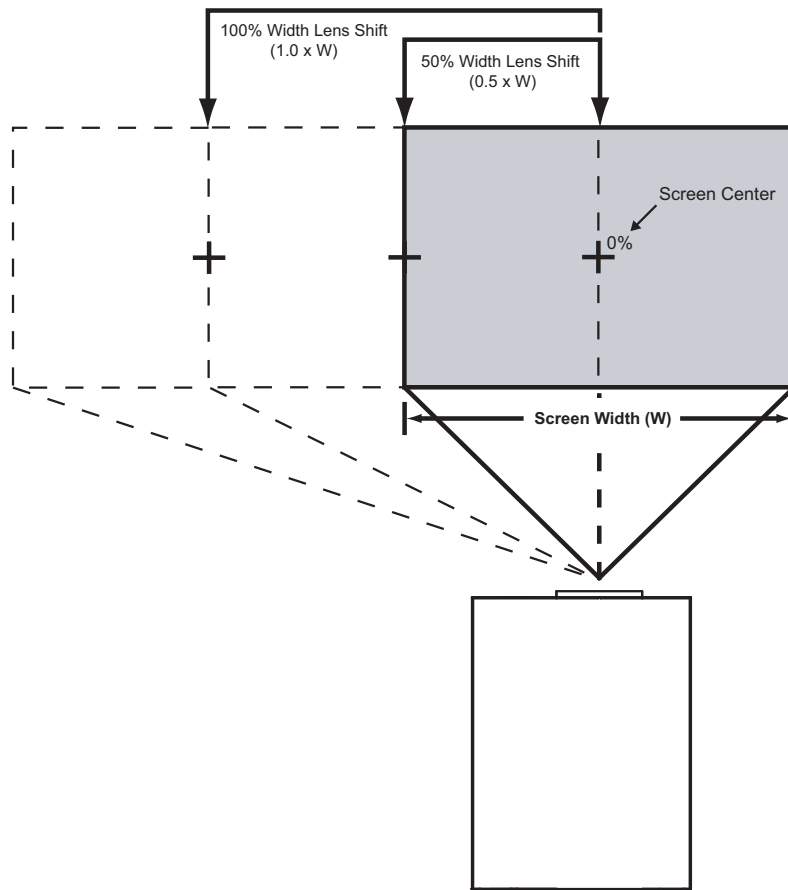

**Note:** This is a general example of lens shift. Lenses vary in their shift capabilities. **No particular lens or projector is used in this example.**

**Figure 3-4. Horizontal Lens Shift (EXAMPLE ONLY)**

Table 3-4 lists the lens shift limits for each available SC-50d/SC-60d lens, as percentages and absolute measurements with a 120 x 67.5 inch (1.78:1) screen.

**Table 3-4. Vertical and Horizontal Lens Shift Limits**

		Lens Option	
		Athena Uno	Athena Dos Athena Tres Athena Quatro Athena Cinco
<b>Lens Shift Limits, as Percentages of Screen Height or Width (Note 1)</b>			
Vertical (Note 2)	Up	17%	60%
	Down	17%	60%
Horizontal	Left	6%	25%
	Right	6%	25%
<b>Lens Shift Limits in Inches, with a 120-by-67.5 inch (1.78:1) Screen</b>			
Vertical	Up	11.48	40.50
	Down	11.48	40.50
Horizontal	Left	7.20	30.00
	Right	7.20	30.00
<b>Notes:</b>			
1. Vertical shift limits are percentages of the screen height. Horizontal shift limits are percentages of the screen width.			
2. <b>Vertical lens shift figures are for ceiling mount configurations.</b> For floor installations (where the projector is upright), reverse the up/down vertical lens shift percentages.			

**Folded Optics** ➤ In rear-screen applications where space behind the projector is limited, a mirror may be used to fold the optical path, as shown in Figure 3-5. The position of the projector and mirror must be accurately set. If you are considering this type of installation, contact your dealer for assistance.

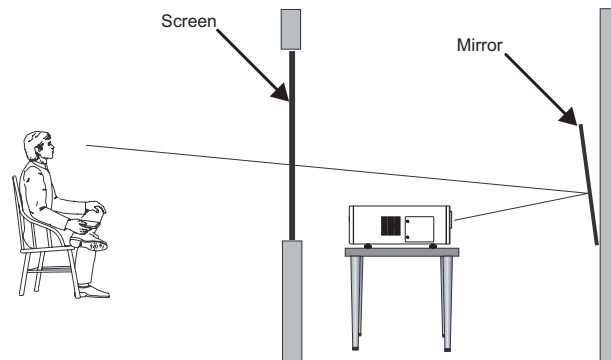

**Figure 3-5. Folded Optics**



**Tip**

*For best performance, always use “first-surface” mirrors in your rear-projection installation (as opposed to conventional, “second-surface” mirrors with the reflective surface behind a transparent substrate such as glass or acrylic).*

*First-surface mirrors provide a strict reflection without the “ghosting” effect seen with a second surface mirror, where a faint secondary reflection could be observed coming from the front surface of the glass.*

Due to its extraordinarily high level of video processing performance, the DHD Controller may distribute video signals with a perceptible level of audio latency. In order to easily solve this issue, Runco recommends using the DHD Controller with a high-quality audio receiver that has the ability to effectively synchronize audio and video signals.

### ◀ **Audio/Video Synchronization Issues**

Most mainstream audio receiver/switchers have the ability to synchronize the audio and video to the Advanced Television Systems Committee (ATSC) prescribed tolerances. According to the ATSC, the sound program should never lead the video program by more than 15 milliseconds, and should never lag behind the video program by more than 45 milliseconds.

In addition, many video displays and A/V receivers introduce additional latency that needs to be compensated for during the installation.

Table 3-5 shows the amount of possible audio latency given different signal input timings.

**Table 3-5. Possible Audio Latency for Various Input Timings**

<b>Input Timing</b>	<b>Possible Audio Latency (milliseconds)</b>
480i	133
480p	83
576i	160
576p	100
720p/50	100
720p/60	83
1080i/25	160
1080i/30	133
1080p/24	125
1080p/50	80
1080p/60	67

- Ventilation** ➤ If you are mounting the SC-50d/SC-60d in an enclosure, leave at least 10 inches (250 mm) of space on the left and right sides between it and surrounding objects, as shown in Figure 3-6. This allows heat to disperse, maintaining the proper operating temperature.

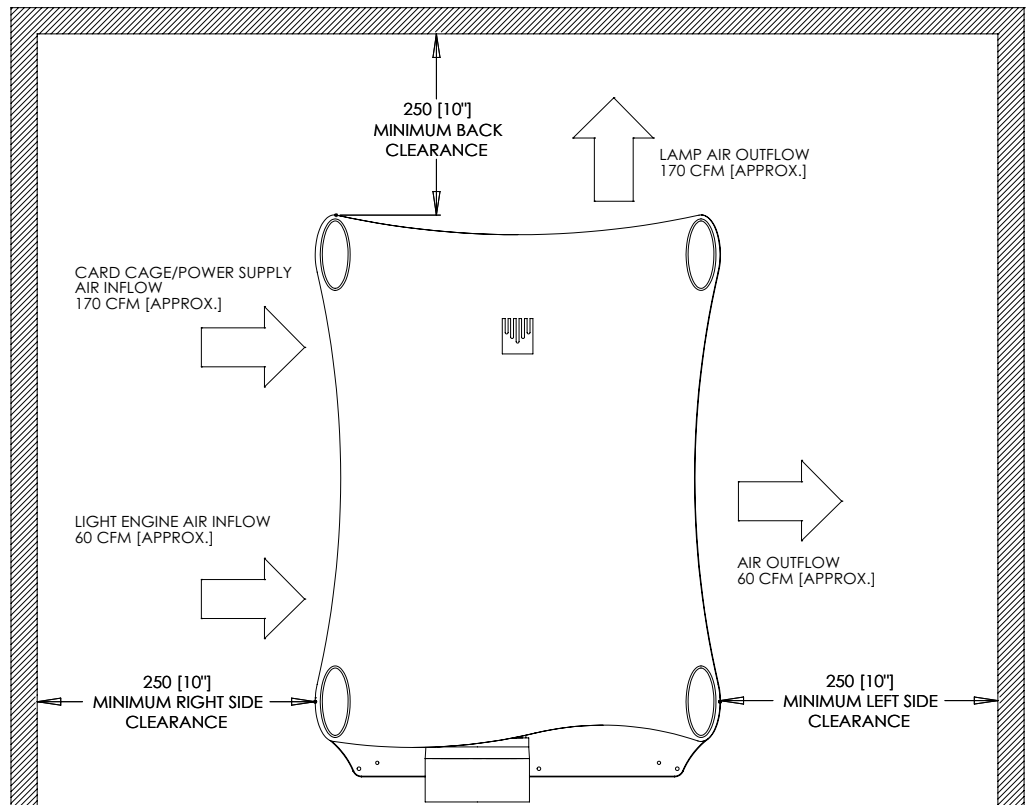

**Figure 3-6. Ventilation Requirements for Enclosure Mounting**

- Other Considerations** ➤ Other considerations and tips that can help improve your installation:
- Keep the ambient temperature constant and below 35°C (95°F). Keep the projector away from heating and/or air conditioning vents. Changes in temperature may cause drifts in the projector circuitry, which may affect performance.
  - Keep the projector away from devices that radiate electromagnetic energy such as motors and transformers. Common sources of these include slide projectors, speakers, power amplifiers and elevators.



The projection lens is shipped separately from the projector. Proceed as follows to install it:

1. Remove the lens plug from the lens opening in the projector.



### **WARNING**

**Never operate this projector without a lens.** The lens seals the projector, preventing contaminants from entering the interior of the projector.

2. Remove the rear cap from the lens. (Keep the front lens cap on the projection lens to protect it from damage during the installation process.)
3. Rotate the lens clamp to the OPEN position.

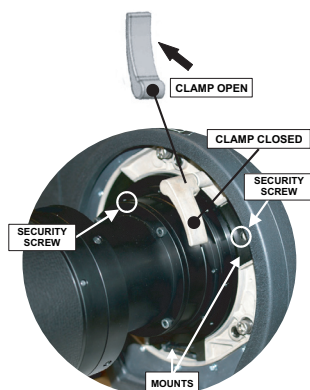

4. Remove and retain the two security screws from the lens mount.

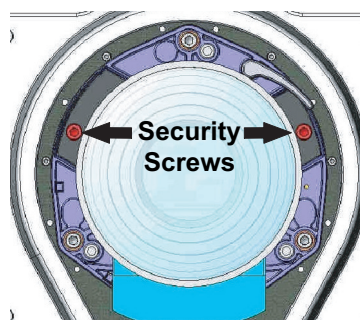

5. Align the lens interface plate with the lens mount. Align the lens electrical connector with the mating connector on the lens mount. Fully insert the assembly straight into the lens mount opening without turning. Press using your hand.



### **Note**

When installing the lens, ensure that it is not inserted at an angle, as this can cause damage.

6. While holding the lens flat against the lens mount, rotate the lens clamp clockwise to lock the lens assembly in place.
7. Re-attach the lens mount security screws that you removed in Step 4.
8. Remove the front lens cap.

## **3.4 Installing the Primary Projection Lens**

### 3.5 Installing the Optional CineWide with AutoScope Lens Motor

If you are installing a standard SC-50d/SC-60d (without an anamorphic lens), skip this step and proceed with **Mounting the SC-50d/SC-60d** (page 27).

If you are installing an SC-50d/CineWide with AutoScope or SC-60d/CineWide with AutoScope, proceed as follows to install the lens mount/motor assembly.



#### Note

1. Do not install the CineWide lens yet, only the AutoScope lens motor. You will install the CineWide lens after you install the projector and adjust the primary lens.
2. Some components shipped with your projector may differ slightly from what is shown in these instructions.
3. The anamorphic lens mounting kit is partially pre-assembled at the factory – the AutoScope lens motor and lens mounting assemblies are both fully assembled.

#### Remove Projector Front Feet

Place the projector upside down on a blanket or other soft surface. Loosen and remove the two front feet on the projector.

#### Install Anamorphic Lens Motor

Line up the eight mounting holes on the lens motor housing with those on the bottom of the projector. Secure the motor to the projector with the eight screws provided for this purpose. See Figure 3-7. Then, connect the +12V trigger input on the motor to a +12V trigger output on the DHD Controller as shown in Figure 3-18.

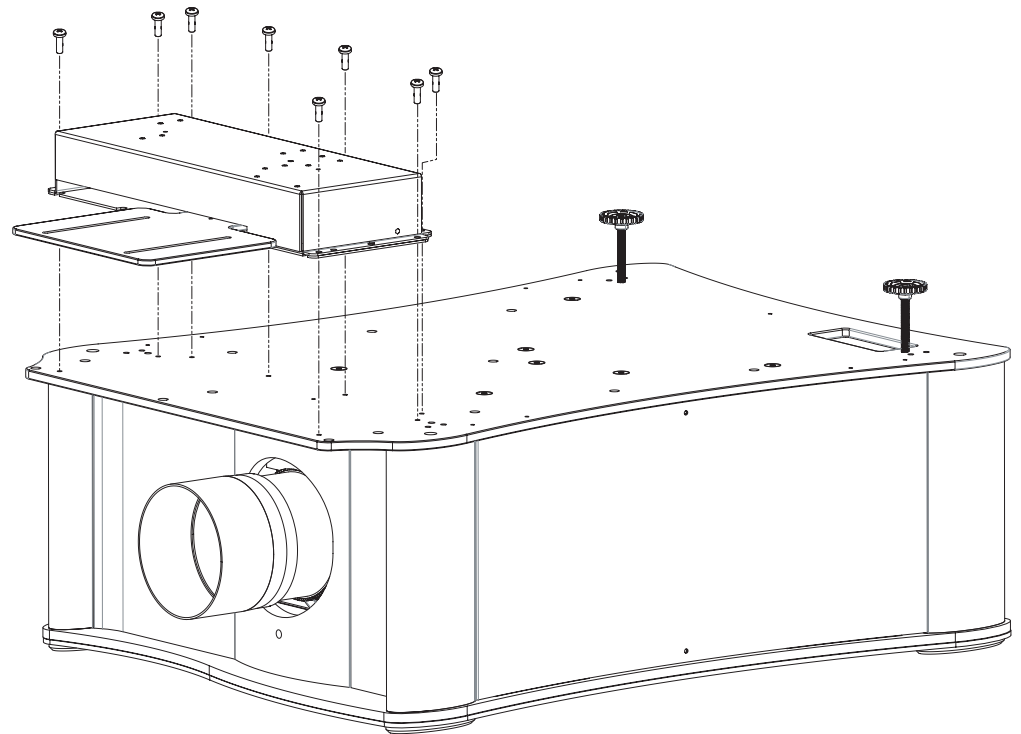

**Figure 3-7. Attaching the AutoScope Lens Motor to the Projector**



#### Caution

**DO NOT OVER-TIGHTEN THE SCREWS.**

There are several methods for mounting the projector. Depending on your chosen installation, one method may be more suitable than another.

In typical front and rear screen installations, the projector can be mounted to a secure and level surface such as a table or cart. Carts are useful when moving a projector during a presentation or from site to site. If possible, lock the wheels when it's in position to prevent it from being moved during a presentation.

For fixed installations, and for those that want the projector out of sight or have a limited space for projector and audience, you can invert the SC-50d/SC-60d and suspend it from the ceiling using a specially-designed ceiling mount fixture.

**Note**

*Use only the Runco-approved ceiling mount kit designed for your projector.*

Install the ceiling mount kit according to the instructions provided with the kit.

The projector can also be inverted and placed in an enclosure above and behind the viewing area. Install four feet on the inside bottom surface of the enclosure on which the projector can rest. A variety of materials can be used for this purpose (for example, rubber crutch tips or turntable feet).

---

### 3.6 Mounting the SC-50d/SC-60d

#### ◀ **Floor Mounting (Upright)**

#### ◀ **Ceiling Mounting (Inverted)**

#### ◀ **Installing the Projector in an Enclosure**

**Adjusting the Projection Angle** ➤

If the screen is significantly higher or lower than the projector, you can also tilt the projector at a slight angle. In a ceiling installation, you do this by adjusting the ceiling mount.

For a floor installation, turn the adjustable feet at the bottom of the projector to adjust the projection angle.

The projector can be rotated (front-to-back) up to 360 degrees and mounted without it affecting performance. However, to ensure optimal performance of the lamp, limit the side-to-side tilt of the projector to  $\pm 20$  degrees; see Figure 3-8.

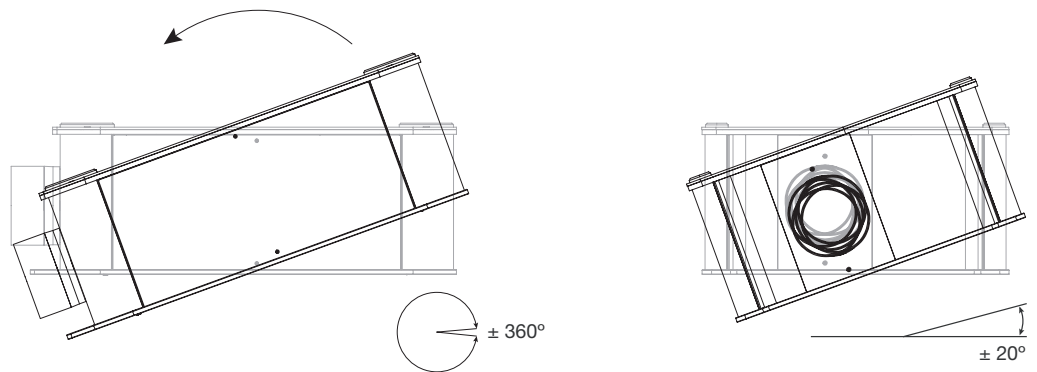

**Figure 3-8. Mounting Angle Ranges (Front-to-Back and Side-to-Side)**

If you do this, you may need to vertically shift the image to compensate. For detailed instructions, refer to **Primary Lens Adjustments: Focus, Zoom and Position** on page 41.

Proceed as follows to connect the DHD Controller to the SC-50d/SC-60d, your video sources, external controller(s) – if present – and AC power.

When connecting your equipment:

- Turn off all equipment before making any connections.
- Use the correct signal cables for each source.
- For best performance and to minimize cable clutter, use high-quality cables that are only as long as necessary to connect two devices. (Don't use a 20-foot cable when a 6-foot cable will suffice.)
- Ensure that the cables are securely connected. Tighten the thumbscrews on connectors that have them.

**Digital Video Connection:** Connect the “HDMI Out To Display” connector on the DHD Controller to the DVI-I input in **Slot 2** of the SC-50d/SC-60d as shown in Figure 3-9.

### 3.7 Connections to the SC-50d/SC-60d and DHD Controller

#### ◀ Connecting the DHD Controller to the SC-50d/SC-60d

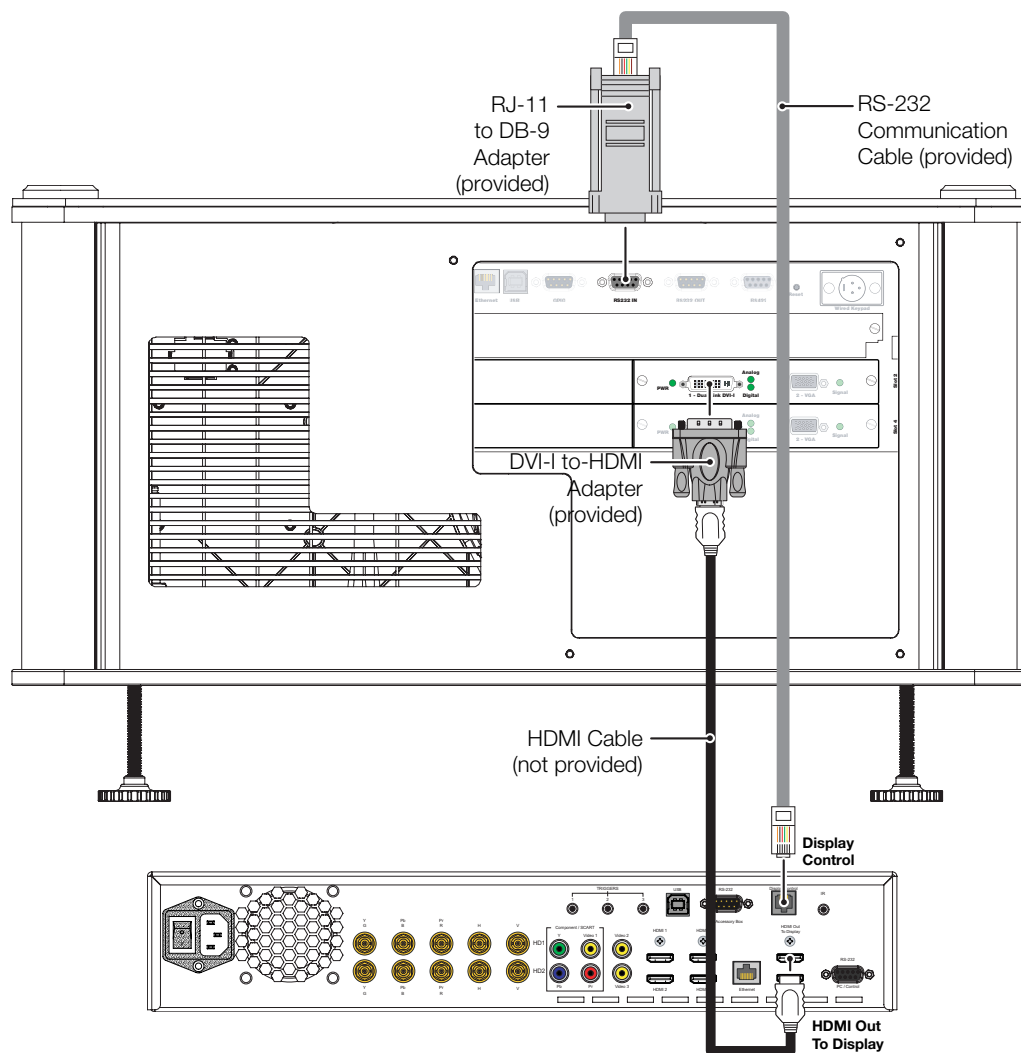

**Figure 3-9. Connecting the SC-50d/SC-60d to the DHD Controller**

**RS-232 Connection:** Connect the **Display Control** output from the DHD Controller to the **RS-232** input on the SC-50d/SC-60d. Use a standard, modular telephone cable with RJ11 plugs at both ends. On the SC-50d/SC-60d end, use the provided RJ11-to-DB9 adapter. This adapter is wired as shown in Figure 3-10.

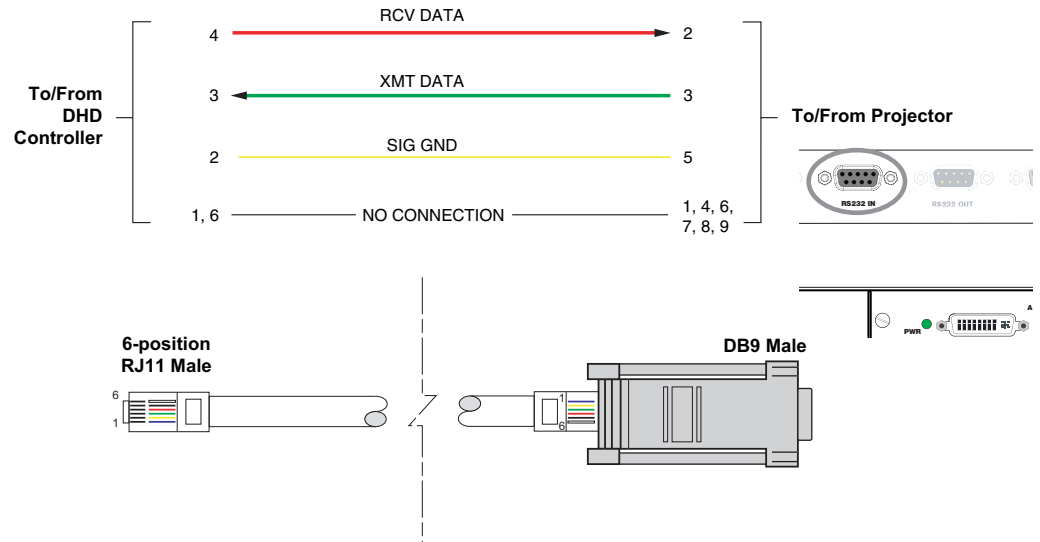

**Figure 3-10. RS-232 Connection from the DHD Controller to the SC-50d/SC-60d**

Connect your video sources to the DHD Controller as shown and described in the sections that follow.

◀ **Connecting Source Components to the DHD Controller**

**HDMI Source Connections:** See Figure 3-11.



**Tip**

Use the HDMI inputs whenever possible. This ensures the highest video quality because the signal is carried in the digital domain throughout the entire signal path, from source component output into the projector.



**Note**

You can also connect computers with DVI output to these inputs. Refer to **Supported Timings** on page 103 for a list of compatible input signals.

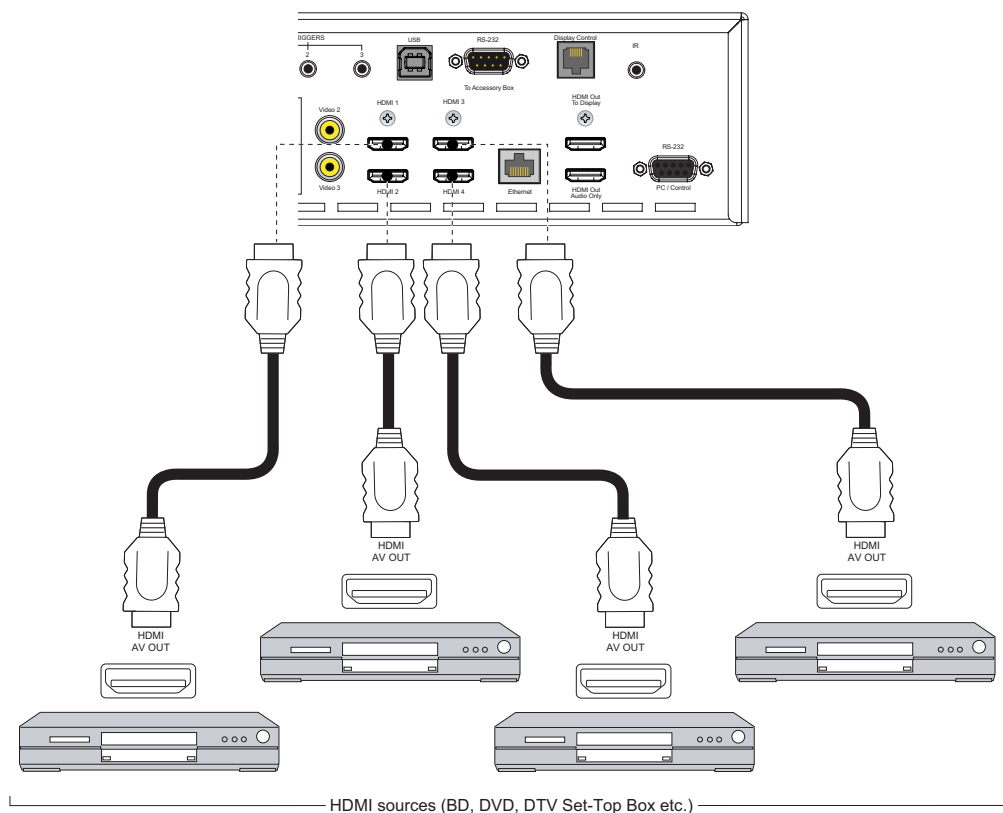

**Figure 3-11. HDMI Source Connections**

**Component Video Source Connections:** Connect your component video sources to the HD1, HD2 and/or Component/SCART inputs as shown in Figure 3-12.

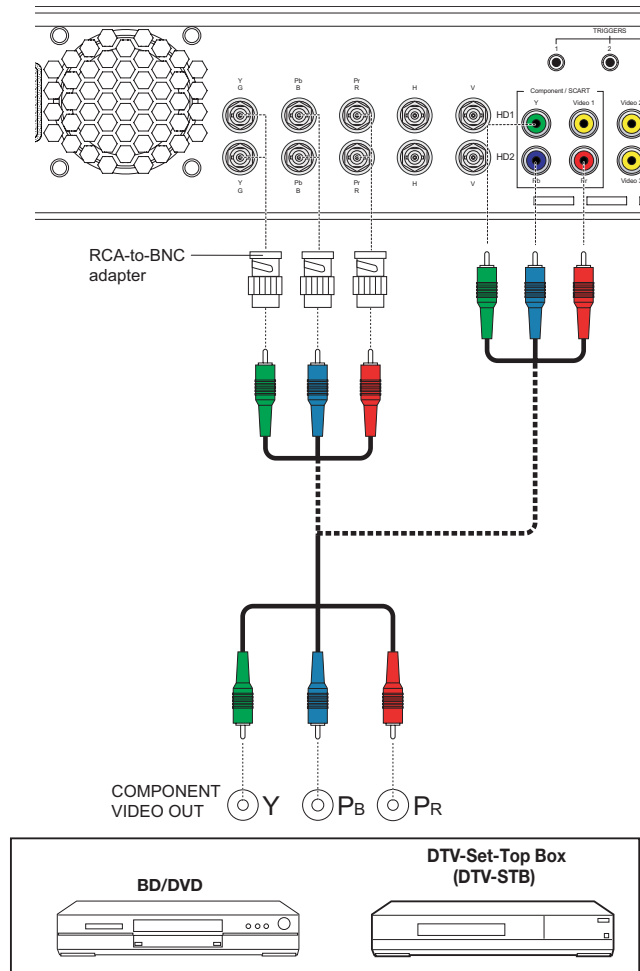

**Figure 3-12. Component Video Source Connections**



**RGBHV Source Connections:** Connect personal computers and/or other RGB sources to the HD1 and/or HD2 inputs as shown in Figure 3-13.

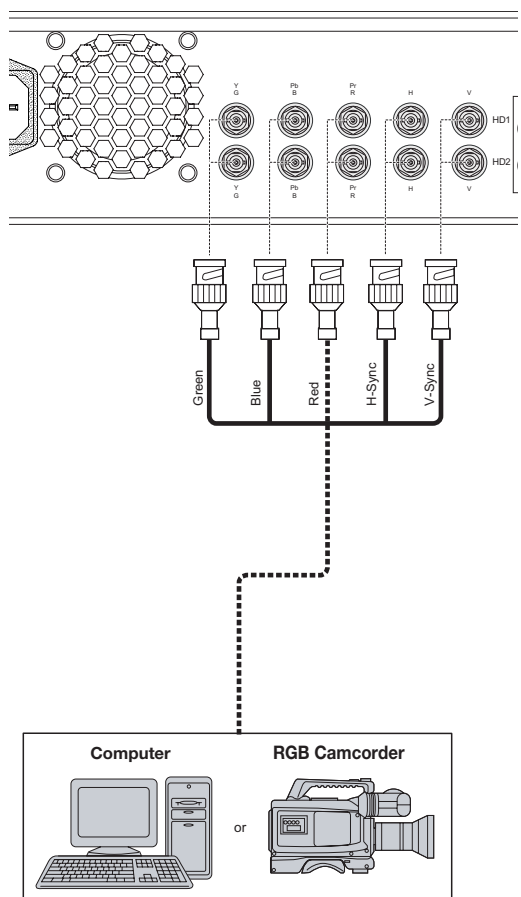

**Figure 3-13. RGBHV Source Connections**

**SCART RGBS Source Connections:** Connect the green, blue and red outputs from your SCART source to the Component/SCART input on the DHD Controller. Connect the sync output from your SCART source to the **Video 1** input on the DHD Controller. See Figure 3-14.

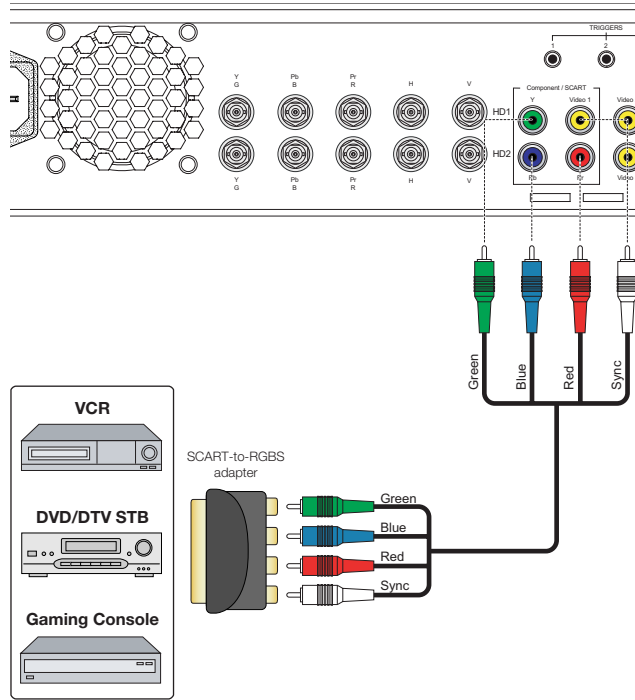

**Figure 3-14. SCART RGBS Source Connections**

**Composite Source Connections:** See Figure 3-15.

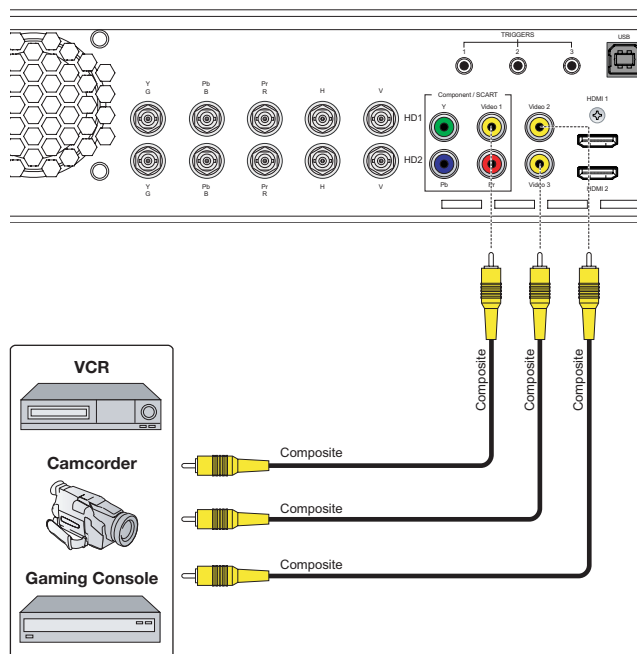

**Figure 3-15. Composite Video Source Connections**

**Connecting an Audio Processor or Secondary Display Device to the DHD Controller (Optional)**

The DHD Controller provides a second HDMI output (labeled **HDMI Out (Audio Only)**) for connection to an audio receiver/switching system or secondary display device for monitoring purposes. See Figure 3-16.



**Note**

*The DHD Controller does not transmit HDMI CEC control messages from the "HDMI Audio Out" connector. For more information about CEC, refer to **Using HDMI CEC Messages** on page 94.*

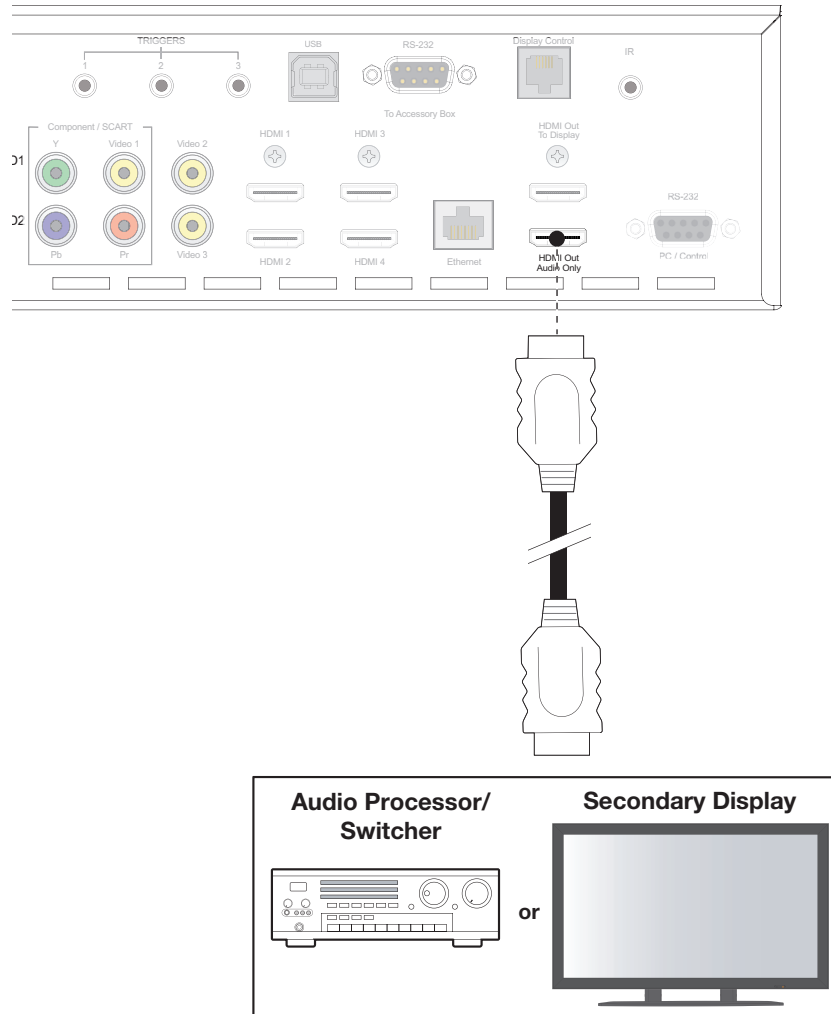

**Figure 3-16. Audio Processor Connection to DHD Controller**

The DHD Controller provides the following interfaces to external equipment that allow it to control or be controlled by that equipment:

- An RS-232 interface to a PC or control/automation system;
- Three (3), 12-volt trigger outputs;
- An infrared (IR) repeater input;
- An Ethernet network interface for firmware updates and maintenance notifications.

◀ **Additional Connections to the DHD Controller (Optional)**

The following sections describe how to make these interface connections. For more information about using these connections, refer to **Network** on page 71 and **External Control** on page 85.

**RS-232 Controller Connection:** Use a straight-through, 9-pin RS-232 cable to connect a PC or control/automation system (if present) to the RS-232 port on the DHD Controller; see Figure 3-17.

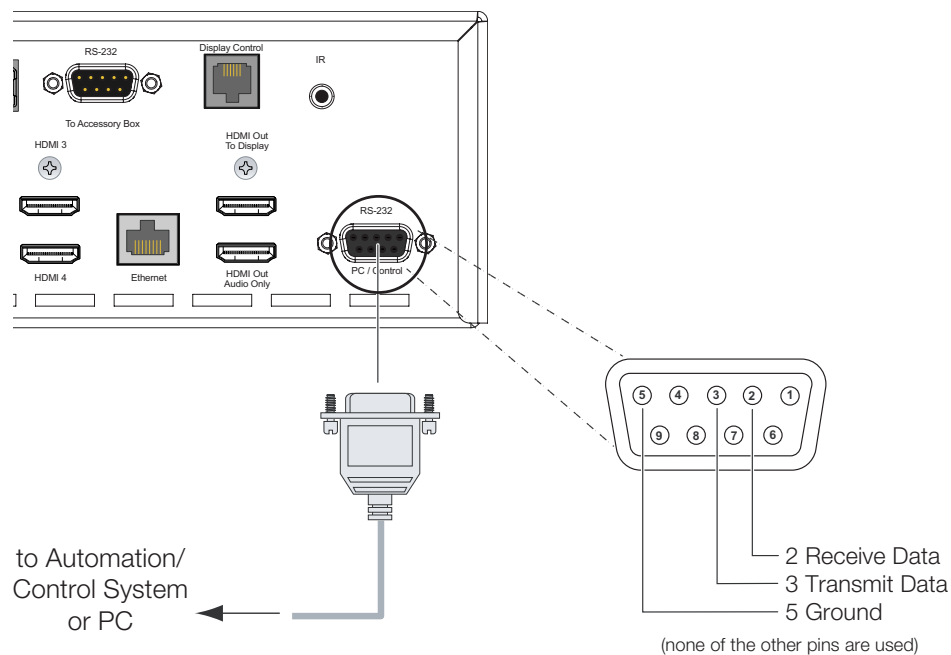

**Figure 3-17. RS-232 Control System Connection to DHD Controller**

**Connecting 12-volt Trigger Outputs to External Equipment:** If you are installing an SC-50d/CineWide with AutoScope or SC-60d/CineWide with AutoScope, connect the AutoScope lens motor to a 12-volt trigger output on the DHD Controller; see Figure 3-18.

Similarly connect other 12-volt trigger-activated equipment (such as retractable screens or screen masks) to the other trigger outputs.

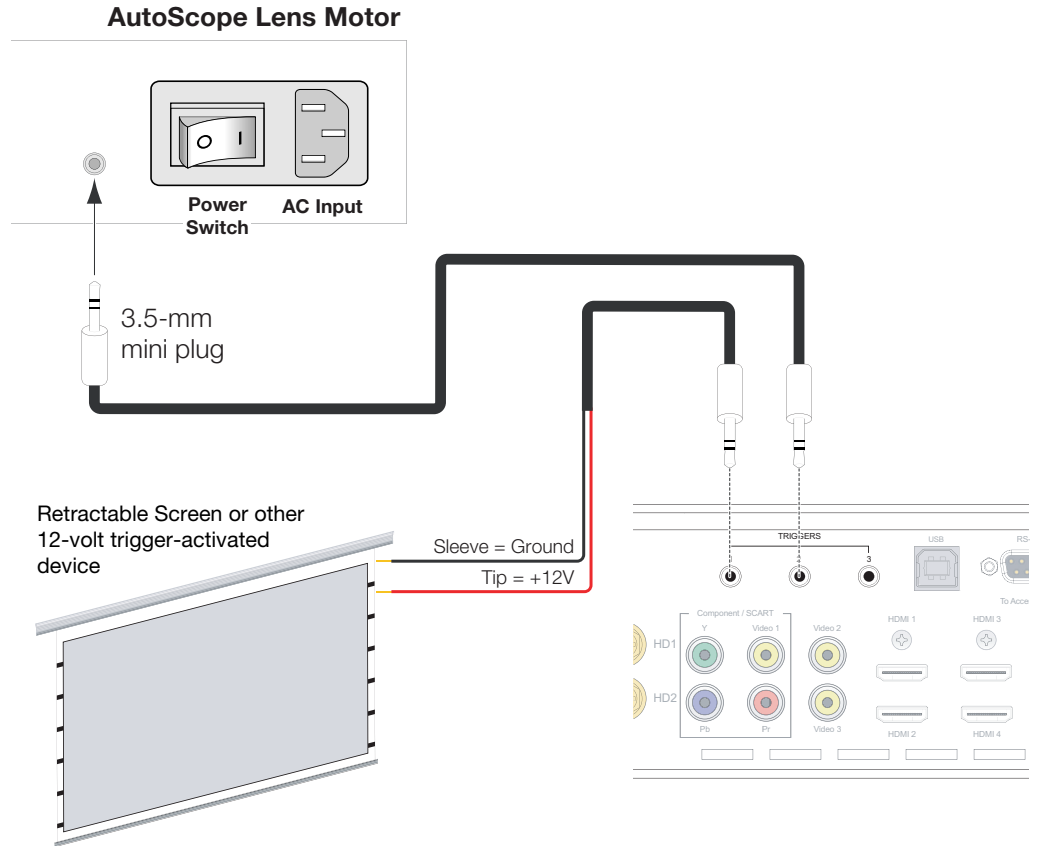

**Figure 3-18. Connecting 12-volt Trigger Outputs**

**Connecting an External IR Receiver to the DHD Controller:** If infrared signals from the remote control cannot reach the DHD Controller due to excessive distance or obstructions such as walls or cabinet doors, you can connect an external IR receiver to extend the range of the remote control. See Figure 3-19.

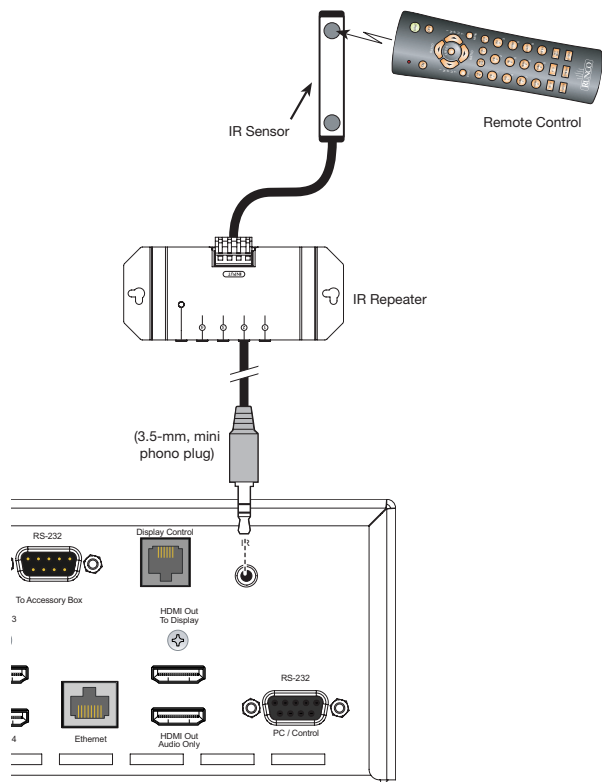

**Figure 3-19. External IR Receiver Connection**

**Ethernet Network Connection:** Use a standard, Category 5 network cable with an RJ-45 plug to connect a network hub, router or gateway to the Ethernet port on the DHD Controller; see Figure 3-20. For more information about configuring and using this connection, refer to **Network** on page 71.

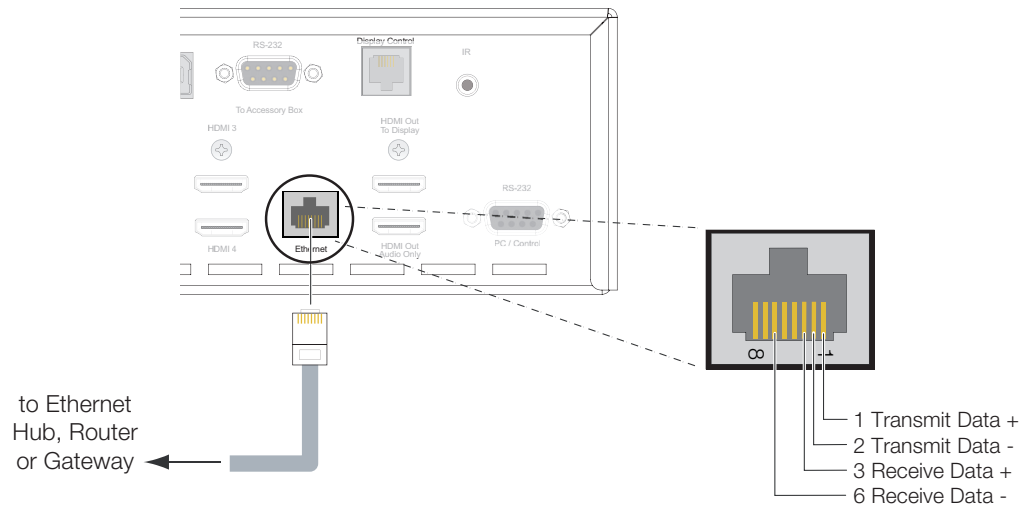

**Figure 3-20. Ethernet Network Connection to DHD Controller**

**Connecting to AC Power** ➤

**Projector and DHD Controller:** The SC-50d/SC-60d ships with two (2), AC power cords: one for the DHD Controller and one for the projector. **They are not interchangeable.** The projector power cord is rated at 15 amps and has a ferrite sleeve, to reduce radio frequency interference (RFI) emissions to a level that conforms to FCC regulations:

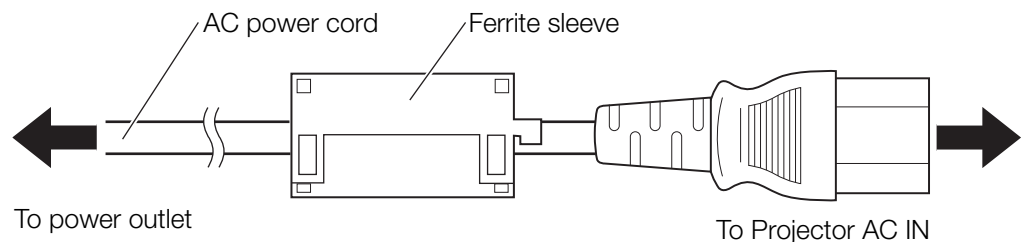

Plug the female end of the projector power cord into the AC receptacle on the rear of the SC-50d/SC-60d (AC 100V ~ 240V); see Figure 2-2. Then, connect the other end to your AC power source.



**WARNING**

**Use ONLY the AC power cord with the ferrite sleeve to connect the projector to AC power. Doing otherwise creates a fire hazard risk.**

Connect the DHD Controller to a nearby AC outlet using the other AC power cord.

**AutoScope Lens Motor:** With AutoScope-equipped projectors, an additional power cord is provided for the lens motor. Plug the female end of the AC power cord into the AC input on the rear of the lens motor assembly. Connect the other end to your AC power source.



1. Power up your source components.
2. Turn on the main power switch at the rear of the projector.
3. If this is an AutoScope-equipped projector, turn on the main power switch at the rear of the AutoScope lens motor. The lens motor power switch is located next to the AC input (see Figure 3-18).
4. Turn on the main power switch at the rear of the DHD Controller.
5. Press the **ON** button on the remote control (or the **ON/STANDBY** (⏻) button on the DHD Controller front panel) to turn on the system. The vacuum fluorescent display on the DHD Controller front panel briefly displays "Initializing System," followed by "Starting SC-50d/SC-60d."
6. When the display is ready for use, the fluorescent display indicates the active source, input resolution/frame rate and aspect ratio; for example:

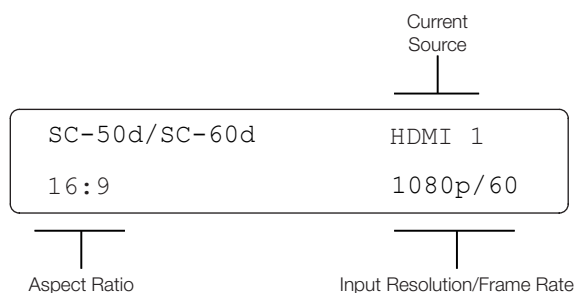

Lens zoom, focus and position are motorized adjustments that are adjustable using the Setup remote control (Figure 2-6). This allows you to adjust the focus and image size while at the screen for more accurate results.



**Tip**

*For maximum range, point the remote directly at the projector.*

To access the lens controls, press the **MAIN** button on the Setup remote control to display the Main Menu page (if not already displayed). Then:

- **Focus:** To focus the projected image, press **FOCUS**, then press and hold the **FOCUS▲** or **FOCUS▼** button.
- **Zoom:** To make the picture smaller (zoom out), press **ZOOM**, then press and hold the **ZOOM-** button. To enlarge the picture (zoom in), press and hold the **ZOOM+** button.
- **Lens Shift:** To change the lens (and projected image) position, press **LENSS**, then press and hold the **LENSS▲**, **LENSS◀**, **LENSS▶** or **LENSS▼** button.



## 3.8 Turning on the Power

## 3.9 Primary Lens Adjustments: Focus, Zoom and Position

### 3.10 Adjusting the Picture Orientation

By default, the SC-50d/SC-60d is configured for a “floor/front” installation, in which the projector is installed upright and in front of the screen. If it is installed behind the screen and/or mounted on a ceiling, you must change the picture orientation. To do this:

1. On the DHD Controller remote control or front panel, press **MENU**.
2. Select **Service** from the Main Menu and enter the Service Menu passcode.



**Note**

*You must enter a passcode to access the Service menu.*

3. Select **Display Device** from the Service Menu.
4. Select **Configure** from the Display Device menu, then select **Installation**.
5. Select **Orientation**, then choose Floor/Rear, Ceiling/Front or Ceiling/Rear, to match the installation method.

Projector and/or screen placement — among other things — can cause geometric distortion in the projected image.

To correct this, the DHD Controller provides precise, nine-point control over the projected image geometry. Use these controls as (and **only if**) needed to re-position the image corners, mid-points and center to eliminate “keystoning” (mis-aligned corners) or “pincushion” distortion (mid-points not aligned with corners). See Figure 3-21.

### 3.11 Adjusting the Image Geometry

#### Horizontal Keystoning

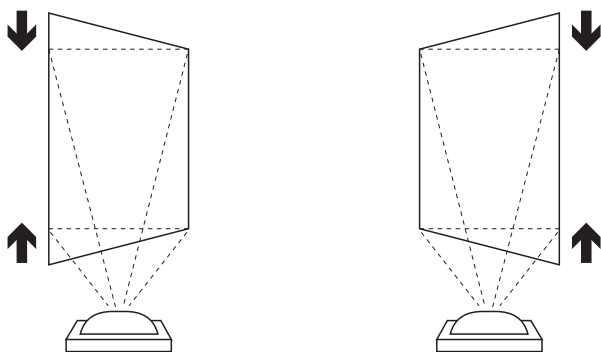

#### Vertical Keystoning

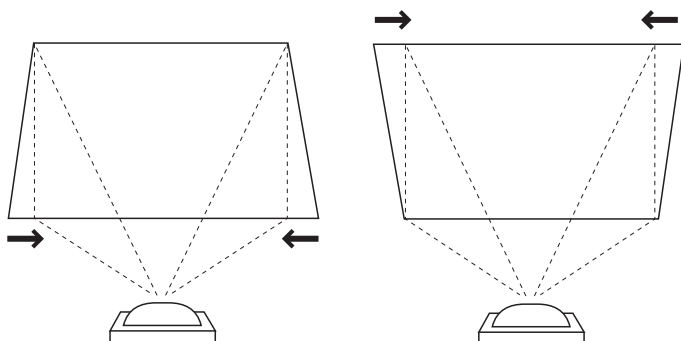

#### Pincushion Distortion

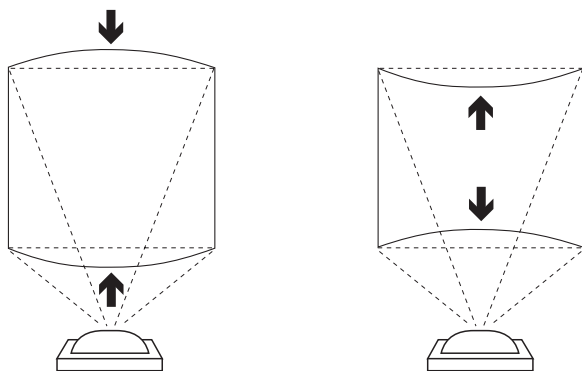

Figure 3-21. Keystone and Pincushion Distortion

“Keystoning” usually occurs when the projector is tilted relative to the screen. “Pincushion” distortion can sometimes occur if the throw distance is very short and/or the projector is equipped with an anamorphic lens.

To correct keystoning or pincushion distortion:

1. On the DHD Controller remote control or front panel, press **MENU**.
2. Select **Calibration** from the Main Menu and enter the Calibration Menu passcode.



**Note**

*You must enter a passcode to access the Calibration menu.*

3. Select **Image Alignment** from the Calibration Menu.
4. Select **Corner Alignment** to correct a “keystoned” image by adjusting the image corner positions. Select **Midpoint Alignment** to correct pincushion distortion by adjusting the image edge mid-points. See Figure 3-22.



**Tip**

*Use the built-in test pattern when adjusting the image corners or midpoints. To access it, check the **Test Pattern** box in the Corner Alignment or Midpoint Alignment menu.*

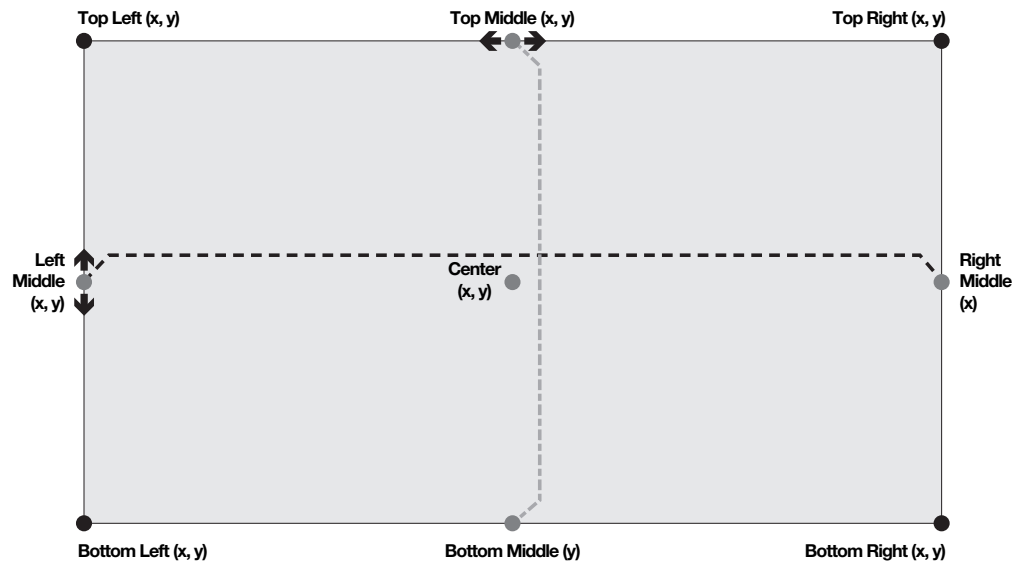

**Notes:**

1. Bottom Middle x = Top Middle x
2. Right Middle y = Left Middle y
3. Smaller “x” values move a point to the left; larger values move it to the right.
4. Smaller “y” values move a point up; larger values move it down.

**Figure 3-22. Image Alignment Controls**



**Note**

*The “Left Middle y” setting also controls the “Right Middle” y-coordinate. Similarly, the “Top Middle x” setting also controls the “Bottom Middle” x-coordinate.*

If you are installing an SC-50d/CineWide with AutoScope or SC-60d/CineWide with AutoScope, proceed as follows to install and adjust the secondary anamorphic lens.



**Note**

***It is extremely important that the primary lens is properly adjusted before you install the anamorphic lens. Ensure that the image from the primary lens is perfectly centered on the screen.***

The SC-50d/SC-60d Anamorphic lens mount kit consists of everything shown in Figure 3-23. Some components shipped with your projector may differ slightly from what is shown in these instructions. If any items are missing or damaged, please contact your Runco dealer or Runco Customer Service at (800) 23-RUNCO.

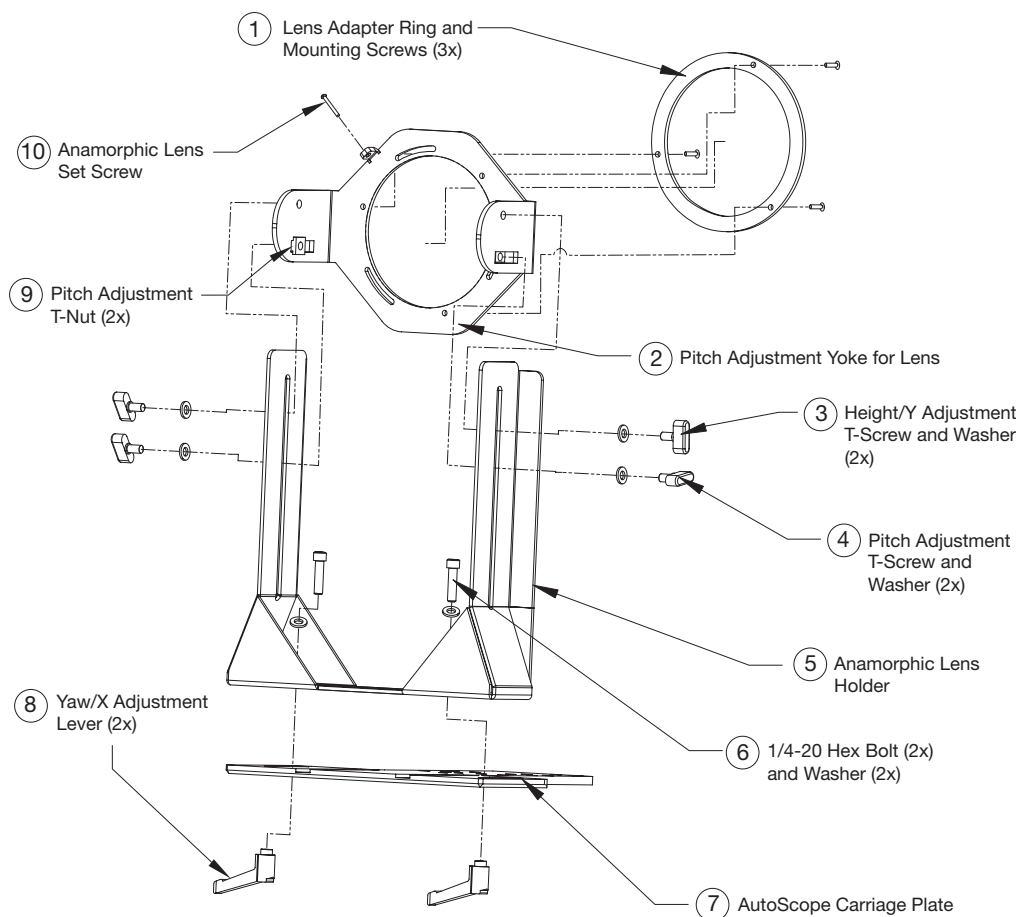
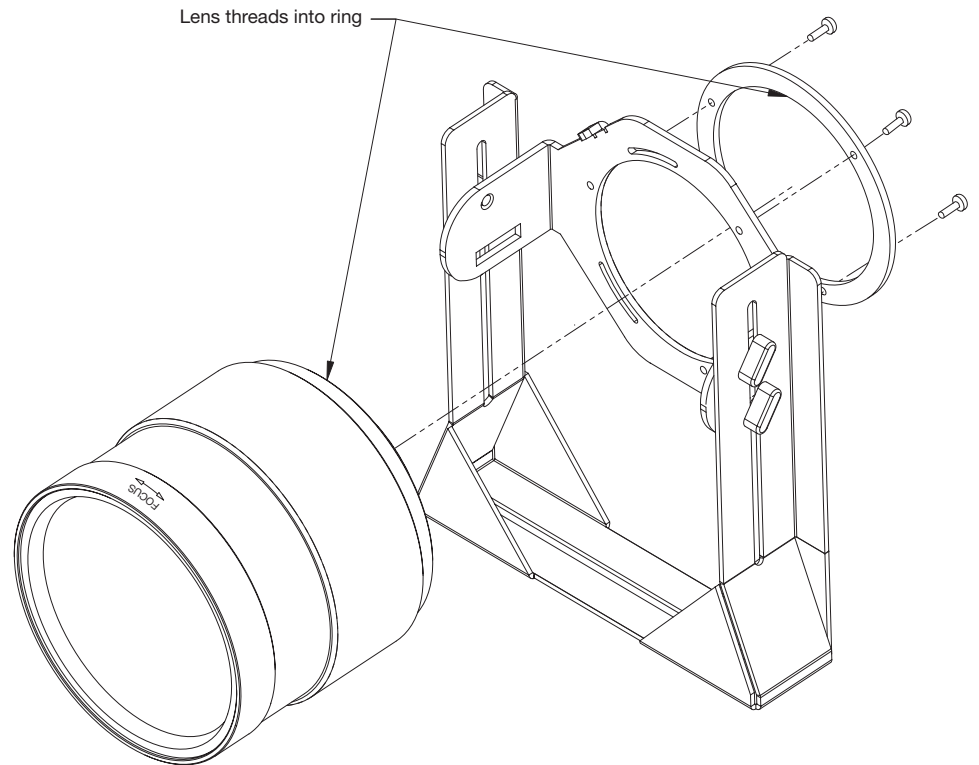

**Figure 3-23. Anamorphic Lens Mounting Assembly - Exploded View**

### 3.12 Installing and Adjusting the CineWide Anamorphic Lens

**Attach Lens Mounting  
Assembly to Lens Motor  
Carriage Plate** ➤

1. Remove the two Yaw/X Adjustment Levers (item #8) from the bottom of the Anamorphic Lens Holder (item #5).
2. Place the Anamorphic Lens Holder on top of the AutoScope Carriage Plate (item #7). Position the bracket so that the long slot at the bottom of the lens holder is perpendicular to the corresponding slots on the plate.
3. Secure the Anamorphic Lens Holder to the plate using the Hex Bolts/Washers (item #6) and Yaw/X Adjustment Levers that you removed in Step 1.
4. Use the Lens Mounting Screws to attach the Lens Adapter Ring (item #1) to the Pitch Adjustment Yoke (item #2); see Figure 3-24. (Use the round, threaded holes on the yoke.)
5. Use the Height/Y Adjustment T-Screws/Washers (item #3), Pitch Adjustment T-Screws/Washers (item #4) and T-Nuts (item #9) to attach the Pitch Adjustment Yoke and Lens Adapter Ring to the Anamorphic Lens Holder. **The Yoke should be as close to the primary lens as possible.**
6. Attach the lens to the Lens Adapter Ring by threading it clockwise.



**Figure 3-24. Attaching the Anamorphic Lens to the Lens Ring**

CineWide with AutoScope maintains constant image height independent of the aspect ratio, while using the full display resolution of the projector. It accomplishes this by moving the anamorphic lens in front of the primary lens when widescreen material is being viewed. When the viewer transitions back to 16:9 or 4:3 source material, the anamorphic lens moves out of the light path.

To configure the lens motor trigger on the DHD Controller for proper AutoScope operation:

1. Project a 2.35:1 aspect ratio test pattern or other image on the screen.
2. On the DHD Controller remote control or front panel, press **MENU**.
3. Select **Service** from the Main Menu and enter the Service Menu passcode.

**Note**

*You must enter a passcode to access the Service menu for the first time after turning on the system.*

4. Select **Triggers** from the Service menu.
5. Assign the trigger output to which the lens motor is connected to the Cinema and Virtual Cinema aspect ratios. This enables the lens motor to move the anamorphic lens into position (in front of the primary lens) when either aspect ratio is selected.
6. Select the Cinema or Virtual Cinema aspect ratio to move the anamorphic lens into position, if it isn't already. To do this, press **CINEMA** or **V-CINE** on the DHD Controller remote control (Figure 2-5), or press **▲** or **▼** repeatedly with no menus visible on-screen.

Refer to Figure 3-23 and proceed as follows:

**Horizontal Position (X) Adjustment:**

1. Project a white field on the screen.
2. Loosen the Yaw/X-Adjustment Levers underneath the lens.
3. Slowly move the anamorphic lens into place (from right to left or vice versa) so that there are no shadows on either side of the screen:

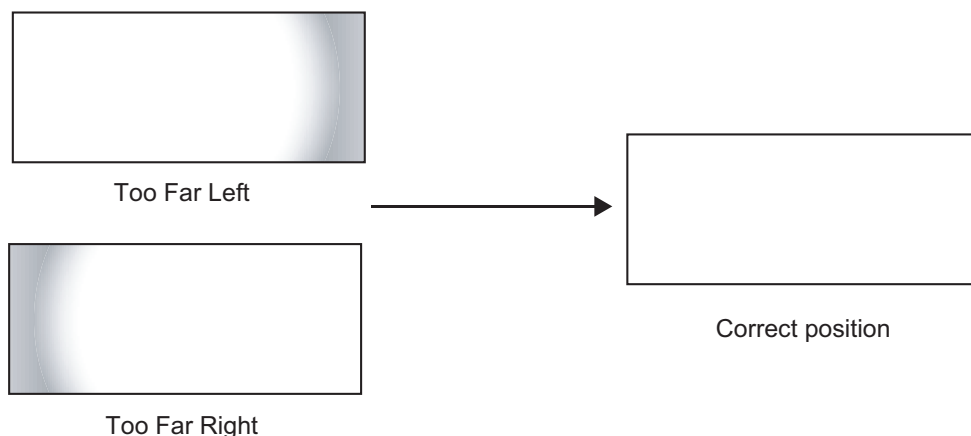

4. When the horizontal position is properly set, tighten the Yaw/X-Adjustment Levers to secure the lens in place.

### ◀ Configure Lens Motor Trigger (CineWide with AutoScope)

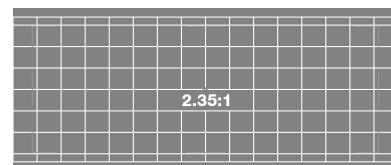

### ◀ Adjust the Anamorphic Lens

**Adjusting the Height (Y):** With the white field still on-screen, loosen the Height/Y Adjustment T-Screws on either side of the lens. Then, slowly move the anamorphic lens into place so that there are no shadows on the top or bottom of the screen:

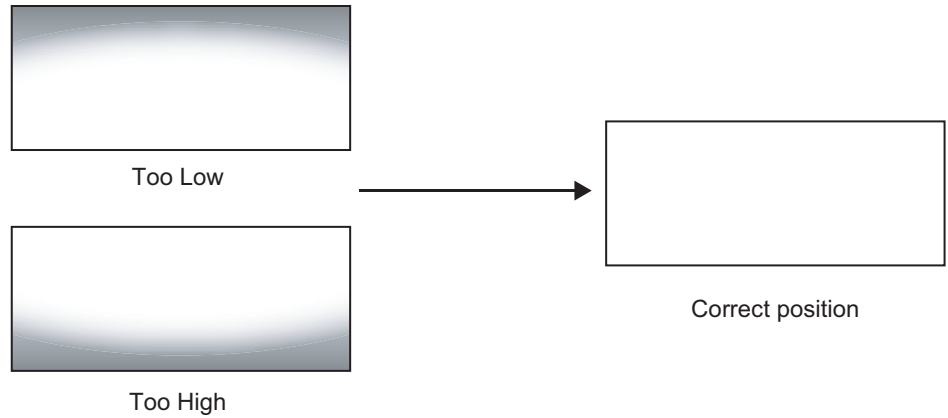

When the height is properly set, tighten the Height Adjustment T-Screws to secure the lens in place.

**Adjusting the Pitch (Angle):** Next, angle the lens to even out any top-to-bottom pincushion distortion. To do this, loosen the Pitch Adjustment T-Screws (directly below the Height/Y Adjustment T-Screws) on either side of the lens to allow it to pivot freely. Then, adjust the anamorphic lens angle so that the projected image is rectangular:

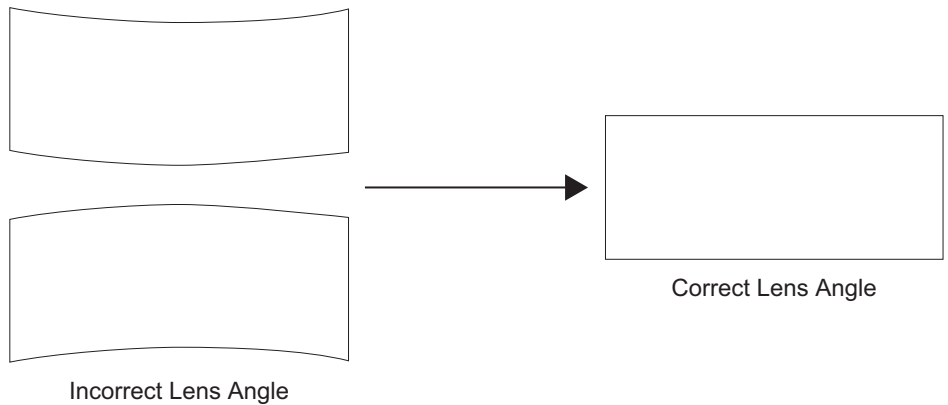

The anamorphic lens will almost always be angled with respect to the projector; this is normal.

Once the proper lens angle has been set, firmly tighten the Pitch Adjustment T-Screws to secure the lens in place.



**Note**

*There may be some pincushion distortion even after the lens is properly adjusted, especially at shorter throw distances. If this is the case, Runco recommends that you slightly over-scan the image into the screen frame area to mask the distortion.*



**Yaw Adjust:** Loosen the Yaw/X-Adjustment Levers to allow the lens to pivot freely from side to side. Then, angle the lens to even out any left-to-right pincushion distortion:

### Anamorphic Lens (Top View)

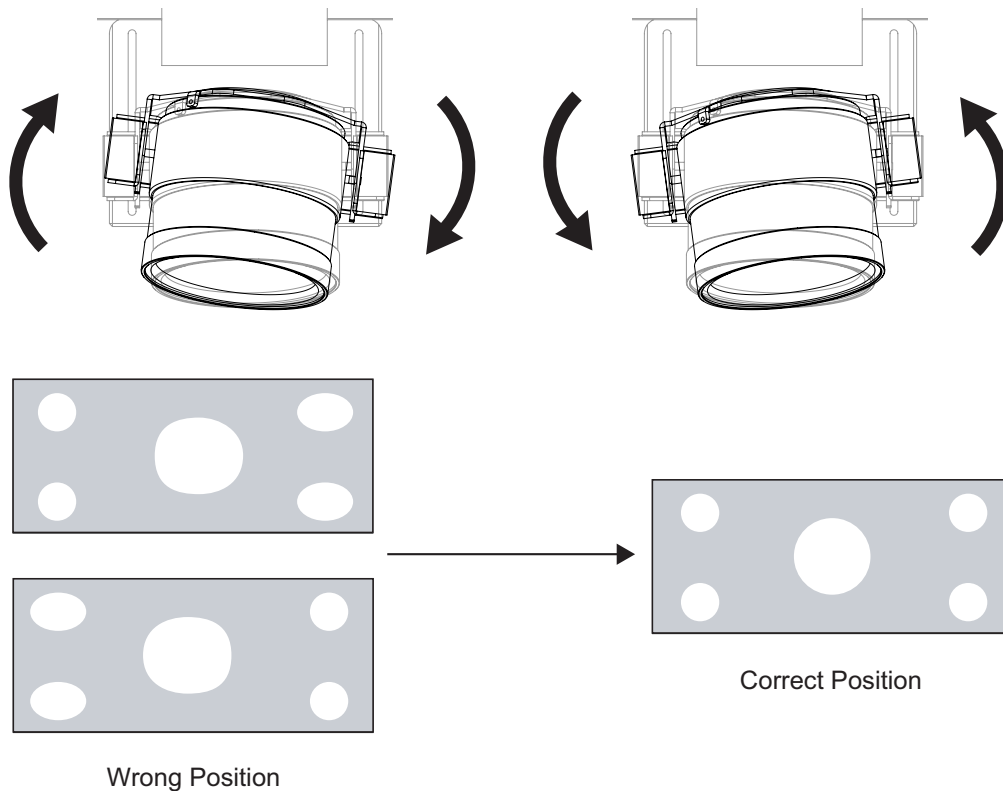

Once the proper lens angle has been set, firmly tighten the Yaw/X-Adjustment Levers to secure the lens in place.

### Geometry:

1. Input an anamorphic cross-hatch test pattern to the DHD Controller.
2. Unscrew the Anamorphic Lens just enough to allow it to rotate freely.
3. Grasp the lens by the center ring and rotate the lens until the image is properly anamorphic:

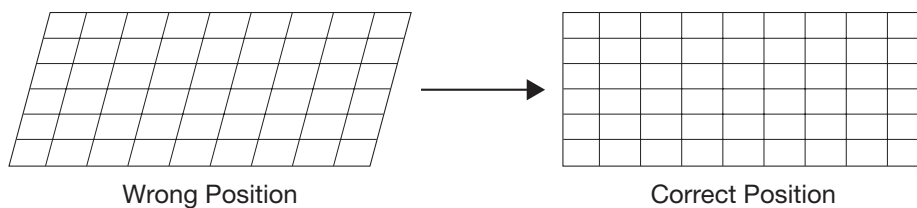

4. When the image geometry appears correct, tighten the Anamorphic Lens Set Screw (item #10) to secure the lens in place. (When viewed from the front, the rear opening on the anamorphic lens should appear as a tall, narrow oval.)



---

**Focus:** Finally, rotate the Focus Ring on the anamorphic lens to fine-tune the optical focus.

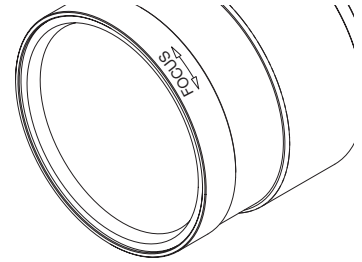

**Verify Proper Image  
Alignment with  
Anamorphic Lens** ➤

After you have installed the anamorphic lens, ensure that the 2.35:1 image corners and edges are aligned with the screen with no geometric distortion. Use the Image Alignment controls to make any necessary adjustments (refer to **Adjusting the Image Geometry** on page 43).

---

**3.13  
Working With the  
Lamp**

At this point you may want to check and adjust the following settings to optimize lamp performance:

- Choose a lamp mode for regulating power and light output.
- Change the optical aperture size.

To access them, choose Calibration from the Main Menu and enter the Calibration menu passcode. Then, choose **Display Color -> Lamp** (refer to **Lamp** on page 66) or **Display Color -> RVR** (refer to **RVR** on page 68).

# 4. Operation

To display the Main Menu, press the **MENU** button on the remote control or DHD Controller front panel (Figure 2-3).

To select a menu item, use the **▲** and **▼** buttons on the remote control or DHD Controller front panel to highlight it. Then, to confirm your selection, press **ENTER** on the remote control or DHD Controller front panel.

The SC-50d/SC-60d OSD menus are arranged hierarchically, as shown in Figure 4-1. Some menu options apply only to certain input signal types. For example, Phase and Tracking can only be adjusted for RGB, Component video or SCART signals.

## 4.1 Using the On-Screen Menus

<b>Input Source</b>	Composite 1	<b>Information</b>	Signal	(read-only)	
	Composite 2		System		
	Composite 3		Network		
	Component		Field Service		
	HD 1		Manufacturing		
	HD 2		<b>Calibration</b>	Gain	-100, -99... <b>0</b> ... 99, 100 (Red, Green, Blue)
	SCART			Offset	
	HDMI 1			Gamma	Mode <b>(Simple / Advanced)</b> Simple (1.00, 1.01, 1.02 ... <b>2.20</b> ... 3.38, 3.39, 3.40) Advanced <b>(0</b> (2.2 gamma curve), 1, 2, 3 ... 20 (custom gamma tables))
	HDMI 2			Lamp	Mode <b>(Power (recommended) / Intensity)</b> Power (SC-50d = 150, 151, 152 ... <b>200W</b> ) (SC-60d = 300, 301, 302 ... <b>350W</b> ... 370) Intensity (0, 1, 2 ... <b>9999</b> )
	HDMI 3			Color Temp	Simple (3200K, 5500K, <b>6500K</b> , 7500K or 9300K)
HDMI 4	RVR	<b>0, 1, 2 ... 9</b>			
<b>Aspect Ratio</b>	16:9	<b>Input Image</b>		Brightness	-50, -49 ... <b>0</b> ... 49, 50
	4:3			Contrast	
	Letterbox			Color	
	VirtualWide			Tint	
	Cinema		Sharpness		
<b>Picture</b>	Virtual Cinema	<b>Input Color</b>	Gain	-32, -31... <b>0</b> ... 31, 32	
	Native		Offset	(HD 1, HD 2 and Component inputs only)	
	Brightness		Chroma Delay	<b>0, 1, 2 ... 7</b> (Composite inputs only)	
	Contrast		Noise Filter	<b>0, 1, 2 ... 63</b>	
	Color		Save ISF Night	Back / Confirm	
<b>Input Position</b>	Tint	Save ISF Day	Copy/Paste	Copy Settings	
	Sharpness		Paste Settings		
	Noise Filter	<b>Output Shift</b>	Left/Right	-50, -49 ... <b>0</b> ... 49, 50	
	Left/Right		Up/Down		
	Up/Down		Width	-50, -49, 48 ... <b>0</b>	
Width	<b>Image Alignment</b>	Corner Alignment	Top Left / Top Right / Bottom Left / Bottom Right		
Height		Midpoint Alignment	Center / Top Middle / Left Middle / Right Middle / Bottom Middle		
<b>Memory Presets</b>	Overscan	<b>Splash Configure</b>	Owner Name		
	Overscan Mode (Zoom/Crop)		ISF Calibrated		
	Phase (RGB/Component/SCART signals only)		ISF Other		
<b>Sleep Timer</b>	Tracking (RGB/Component/SCART signals only)	Splash Timer	5, 6, 7 ... <b>15</b> ... 59, 60		
	Recall ISF Night or ISF Day	Splash Enable	On/Off		
	Recall/Save Custom 1 or Custom 2	OSD Position	Hor. / Ver.	<b>0, 1, 2 ... 100</b>	
	Reset Custom 1 and Custom 2 to Factory Default				

**Note:** Default settings appear in **bold type**.

Figure 4-1. SC-50d/SC-60d OSD Menu Structure

<b>Service</b>	Test Video	Color Bars 1	
		Color Bars 2	
		Focus	
		Grey Bars	
	Input Names	Rename/Restore	
	Display Device - Configure	Picture Orientation	Auto, <b>Floor Front</b> , Ceiling Front, Floor Rear or Ceiling Rear
		Lamp Info. (read-only)	(Projector Serial Number)
		Diagnostics	White, Red, Green, Blue, Yellow, Cyan, Magenta
	Display Device - Auto Calibration	Yes/No	
	Network	IP Configuration	DHCP ( <b>On</b> / Off), IP Address, Subnet Mask, Default Gateway, Communication Test
		Auto Firmware Upgrade	Auto Check for New Firmware, Auto Perform Upgrade, Check for New Firmware
		E-Mail Notification	E-Mail Address, Error Notification, Error Notification to Runco, Periodic Service Notification, Lamp Life Notification, Customer Information, E-Mail Calibration Data
		Remote Network Control	<b>On</b> / Off
	Color Space	<b>Auto</b> , REC601, REC709, RGB-PC or RGB-Video	(Not available on Composite 1, Composite 2 or Composite 3 inputs)
	Triggers	1 / 2 / 3	
	Miscellaneous	Language	English, Français, Deutsch, Italiano, Español, Svenska, Traditional Chinese, Simplified Chinese, Português or Russian
		OSD Timer	0 (no timeout) or 5, 6, 7 ... <b>15</b> ... 60 sec.
		OSD Messages	On / Off
		Blank Screen Color	Red/Green/Blue = <b>0</b> , 1, 2, 3 ... 255
		Sidebar Color	
		Film Mode (SD sources only)	On / Off
		CUE (Chroma Upsampling Error)	On / Off
	Remote Code	00, 01, 02 ... <b>17</b> ... 31	
	Sync Threshold	0, 1, 2 ... 15	(HD 1, HD 2 and Component inputs only)
	HDMI	HDMI EDID Extension	<b>On</b> / Off (per HDMI input)
		Audio Format	Combined / HDMI Out (To Display) / <b>HDMI Out (Audio Only)</b>
		CEC	<b>On</b> / Off
Front Panel Brightness	Logo LED	0 (off), 1, 2 ... <b>31</b>	
	Standby LED	<b>On</b> / Off	
	LCD	0 (off), 1, 2, 3 or <b>4</b>	
Auto Power Off	Enable	On / <b>Off</b>	
	Hours	1, 2, 3, 4, ... <b>8</b> ... 23, 24	
System Reset			

Figure 4-1. SC-50d/SC-60d OSD Menu Structure (continued)

The Main Menu is the starting point for accessing all DHD Controller functions.  
 (You must enter a passcode to access the Calibration and Service menus.)

◀ **Main Menu**

Runco Video	
Input Source	
Aspect Ratio	
Picture	
Input Position	
Memory Presets	
Sleep Timer	
Information	
Calibration	
Service	

From the Main Menu, select Input Source to choose a video signal source.

The active source is indicated by an arrow (➔) to its left; in this example, Composite is the active source.

◀ **Input Source**

Input Source	
➔ Composite 1	
Composite 2	
Composite 3	
Component	
HD 1	
HD 2	
SCART	
HDMI 1	
HDMI 2	
HDMI 3	
HDMI 4	

To change the aspect ratio (size and shape) of the projected image, select Aspect Ratio from the Main Menu and press **ENTER**. Select the appropriate aspect ratio for your screen size and the type of program material being viewed; refer to Table 4-1.

The currently-selected aspect ratio is indicated by a “☒” to its left; in this example, 16:9 is selected.

◀ **Aspect Ratio**

Aspect Ratio	
☒ 16:9	
<input type="checkbox"/> 4:3	
<input type="checkbox"/> Letterbox	
<input type="checkbox"/> VirtualWide	
<input type="checkbox"/> Cinema	
<input type="checkbox"/> Virtual Cinema	
<input type="checkbox"/> Native	

Note that some aspect ratios are unavailable and/or not useful with certain types of source material. The optimal setting depends on a number of factors, such as:

- The aspect ratio of the source material, as broadcast or encoded on the playback medium.
- The “display type” (16:9 or 4:3) and output resolution settings at the source component. Most modern DVD/BD players and set-top boxes have such controls.
- Viewer preference (original aspect ratio with “black bars,” or a full-screen presentation with some distortion or cropping).



*The aspect ratio selection is automatically saved for each input and resolution.*

**Table 4-1. Aspect Ratio Settings**

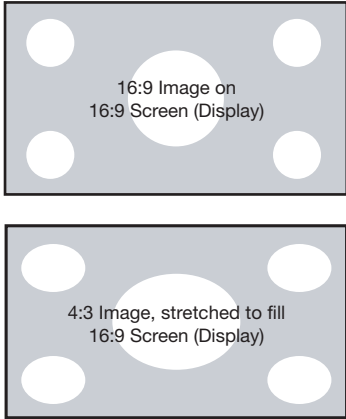
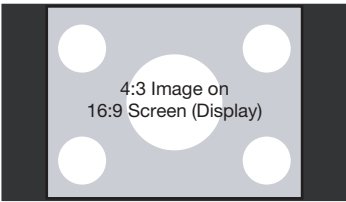
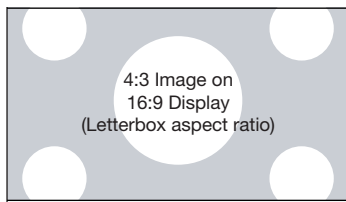
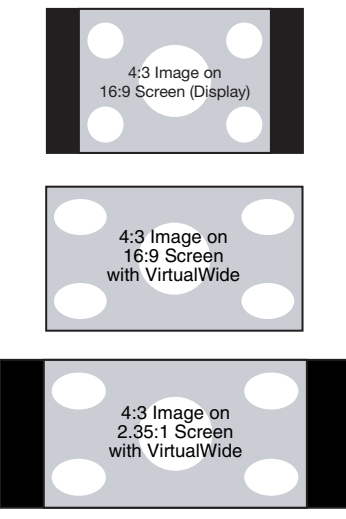
Aspect Ratio	Remote Control Key	Description	
16:9	16:9	 <p>16:9 Image on 16:9 Screen (Display)</p> <p>4:3 Image, stretched to fill 16:9 Screen (Display)</p>	<p>Select 16:9 to view 16:9 DVDs and HDTV programs in their native aspect ratio.</p> <p>4:3 images are stretched horizontally to fit a 16:9 screen.</p>
4:3	4:3	 <p>4:3 Image on 16:9 Screen (Display)</p>	<p>Standard 4:3 scales the input signal to fit in the center of the 16:9 screen. 4:3 is the aspect ratio used by computer monitors, standard television programming and most VHS video cassettes.</p>
Letterbox	LET BOX	 <p>4:3 Image on 16:9 Display (Letterbox aspect ratio)</p>	<p>Letterbox mode scales (zooms in on) a 4:3 image linearly (by the same amount on all sides) to fill a 16:9 display. Letterbox is best suited for viewing LaserDisc movies or non-anamorphic DVDs on a 16:9 screen.</p>
VirtualWide	V-WIDE	 <p>4:3 Image on 16:9 Screen (Display)</p> <p>4:3 Image on 16:9 Screen with VirtualWide</p> <p>4:3 Image on 2.35:1 Screen with VirtualWide</p>	<p>VirtualWide scales a 4:3 image NON-linearly (more on the sides than in the center) to fit a 16:9 screen.</p> <p>On a 2.35:1 screen, the image is centered between black bars on either side.</p>

**Table 4-1. Aspect Ratio Settings (continued)**

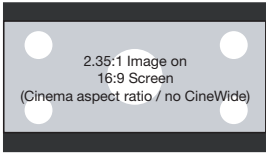
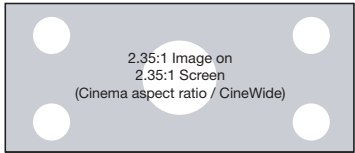
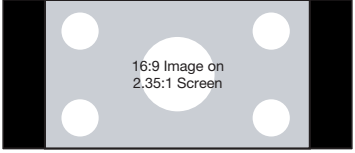
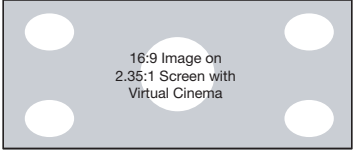
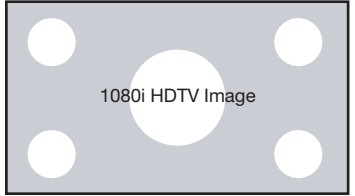
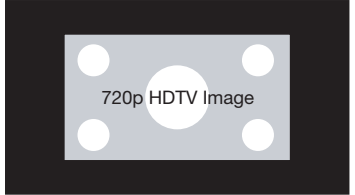
Aspect Ratio	Remote Control Key	Description	
Cinema	CINEMA	 <p>2.35:1 Image on 16:9 Screen (Cinema aspect ratio / no CineWide)</p>  <p>2.35:1 Image on 2.35:1 Screen (Cinema aspect ratio / CineWide)</p>	<p>Select Cinema to view 2.35 source material in its native aspect ratio.</p> <p>With a 16:9 screen and a standard SC-50d/SC-60d (without an anamorphic lens), the upper and lower portions of the screen are masked, but the geometry of the active image area is unchanged.</p> <p>With a 2.35:1 screen and an anamorphic lens, the DHD Controller scales the 2.35:1 image so that the active image area fills the 16:9 chip surface, eliminating the black bars. The secondary, anamorphic lens then restores the proper geometry to the 2.35:1 image.</p>
Virtual Cinema	V-CINE	 <p>16:9 Image on 2.35:1 Screen</p>  <p>16:9 Image on 2.35:1 Screen with Virtual Cinema</p>	<p>A 16:9 image is scaled NON-linearly (more on the sides than in the center) to fit a 2.35:1 screen.</p>
Native	NATIVE	 <p>1080i HDTV Image</p>  <p>720p HDTV Image</p>	<p>Select Native to display the source signal in its native resolution, centered in the display area with no re-sizing or overscan.</p> <p>This means, for example, that 720p HDTV programs will display with unused pixels on all sides: 320 on the left and right sides and 180 above and below.</p> <p>With SDTV and EDTV sources, the DHD Controller scales the image horizontally to achieve a 16:9 aspect ratio.</p>

**Picture** ➤

Picture
Brightness
Contrast
Color
Tint
Sharpness
Noise Filter

Use the controls in the Picture Menu to calibrate each DHD Controller input to achieve optimum picture quality.

The DHD Controller has been designed to incorporate setup and calibration standards established by the Imaging Science Foundation (ISF). The ISF has developed carefully crafted, industry-recognized standards for optimal video performance and has implemented a training program for technicians and installers to use these standards to obtain optimal picture quality from Runco video display devices. Accordingly, Runco recommends that setup and calibration be performed by an ISF certified installation technician.

All signal types require separate processing. Therefore, you need to calibrate each DHD Controller input separately.



**Note**

*When you change a picture quality setting, save the change to a preset afterwards. Otherwise, the change will be lost when a different input is selected. (Picture quality settings are saved for each input and display mode separately.) For information about saving settings, refer to **Memory Presets** on page 62.*

Although it may be possible to obtain satisfactory picture quality using the naked eye and regular program material, Runco recommends using an external test pattern source (Ovation Multimedia, Digital Video Essentials or AVIA test DVD or equivalent) for best results.

Connect your test pattern source to the input that you are calibrating and proceed as follows. **Perform the adjustments in the order listed here.**

**Brightness:** On your external test pattern source, select a PLUGE pattern. (PLUGE is an acronym for “Picture Line-Up Generation Equipment.”) Figure 4-2 shows a typical PLUGE pattern.

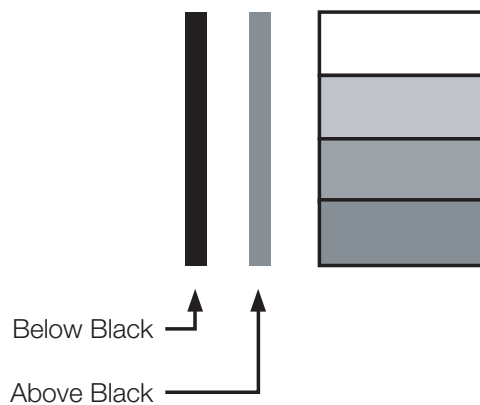

**Figure 4-2. Typical PLUGE Pattern for Adjusting Brightness**



PLUGE patterns vary but generally consist of some combination of black, white and gray areas against a black background. The example above includes two vertical bars and four shaded boxes.

Select Brightness from the Picture menu and press **ENTER**. Adjust the brightness so that:

- The darkest black bars disappear into the background.
- The dark gray areas are barely visible.
- The lighter gray areas are clearly visible.
- The white areas are a comfortable level of true white.
- The image contains only black, gray and white (no color).

**Contrast:** On your external test pattern source, select a stepped, gray-bar pattern like the one shown in Figure 4-3.



**Figure 4-3. Typical Gray Bar Pattern for Adjusting Contrast**

Select Contrast and press **ENTER**. Adjust the contrast to a point just below which the white rectangle starts to increase in size.



*Brightness and contrast controls are interactive. A change to one may require a subtle change to the other in order to achieve the optimum setting.*

**Color Saturation:** On your external test pattern source, select a color bar pattern like the one shown in Figure 4-4.

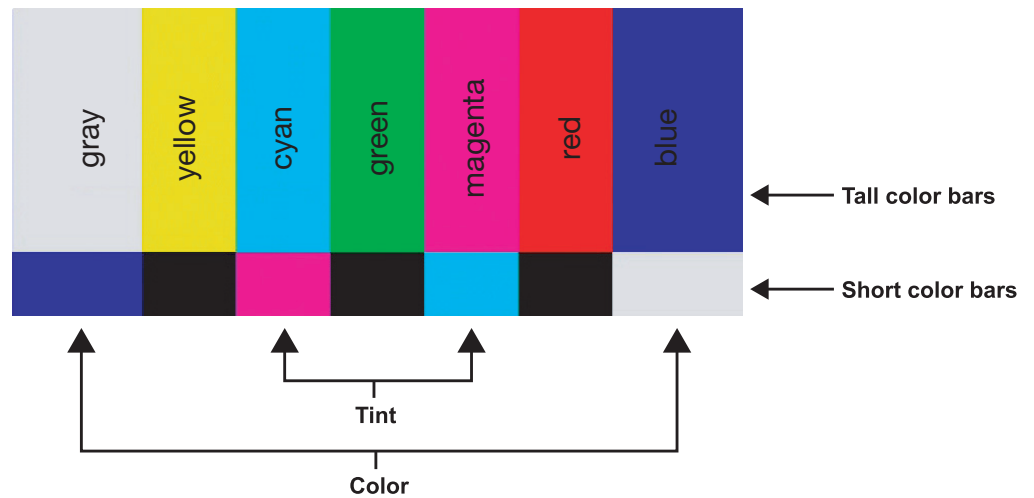

**Figure 4-4. Typical Color Bar Pattern for Adjusting Color Saturation and Tint**

1. Press the **MENU** button on the remote control or DHD Controller front panel.
2. Select Service from the Main Menu and press **ENTER**.
3. Enter the Service menu passcode.
4. Select Display Device from the Service menu and press **ENTER**.
5. Press **ENTER** again to select Configure.
6. Select Diagnostics and press **ENTER**.
7. Select Blue from the Diagnostics menu, then press **ENTER** to display only the blue color channel.
8. Press **EXIT** (or **MENU**) repeatedly to return to the Main Menu.
9. Select Picture from the Main Menu and press **ENTER**.
10. Select Color from the Picture menu and press **ENTER**.

11. Adjust the color saturation level until the outermost (gray and blue) color bars appear to be a single shade of blue:

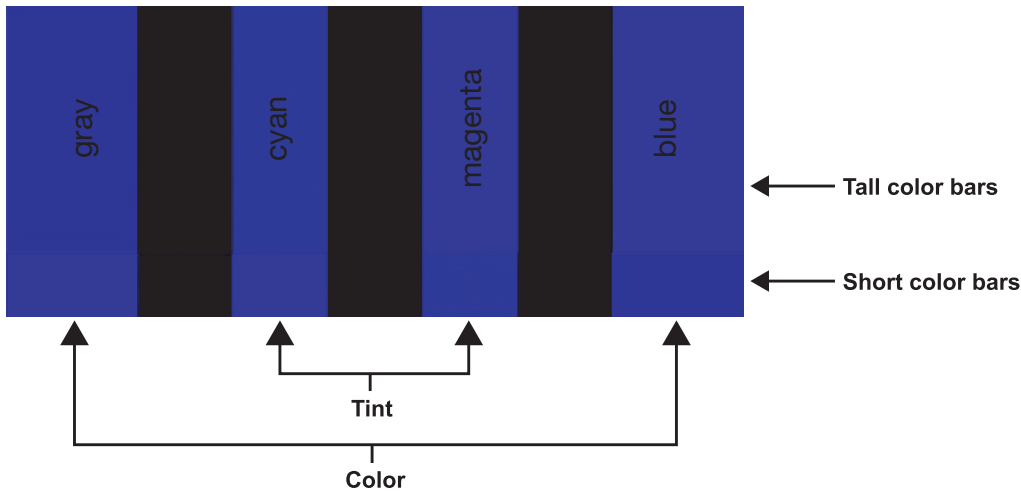

**Tint:** Tint or “hue” is essentially the ratio of red to green in the color portion of the image. When tint is decreased, the image appears redder; when it is increased the image appears greener.

To adjust the tint, enable “blue only” display mode in the Diagnostics menu, as you would for adjusting color saturation (refer to the previous section, **Color Saturation**).

Select Tint from the Picture menu and press **ENTER**. Adjust the tint level until the cyan and magenta color bars (on either side of the green bar) appear to be a single shade of blue.



**Note**

*Like the brightness and contrast controls, the color and tint controls are interactive. A change to one may require a subtle change to the other in order to achieve the optimum setting.*

**Sharpness:** “Sharpness” is the amount of high-frequency detail in the image. To adjust sharpness, select Sharpness from the Picture menu and press **ENTER**. On your external test pattern source, select a pattern like the one shown in Figure 4-5. Adjust as needed, looking for white edges around the transitions from black to gray and differently-sized lines in the “sweep” patterns at the top and bottom. Lower the sharpness setting to eliminate them.

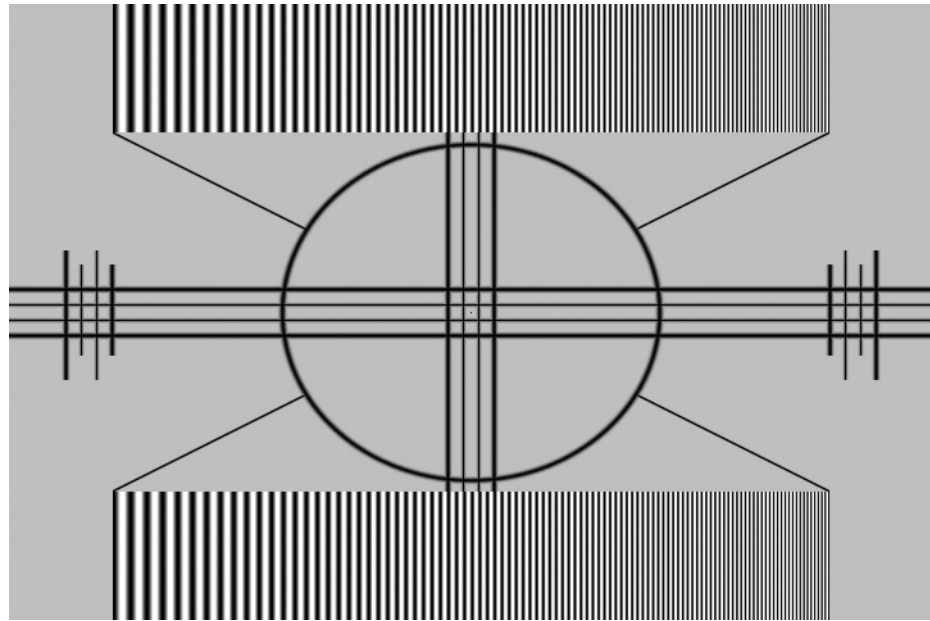

**Figure 4-5. Typical Test Pattern for Adjusting Sharpness**

**Noise Filter:** To apply noise filtering to the input signal, select Noise Filter from the Picture menu. The Noise Filter is useful for clearing up noisy images from 480i video sources.

Use the left- or right-arrow buttons to select the desired amount of noise reduction, keeping in mind that higher settings (which reduce high frequencies) may also “soften” the image.

**Input Position** ➤

Use the controls in the Input Position Menu to fine-tune the aspect ratio and image position for the current source.

Input Position
Left/Right
Up/Down
Width
Height
Overscan
Overscan Mode
Phase
Tracking



**Note**

*The input position settings are automatically saved for each input and resolution.*

**Left/Right:** Select Left/Right from the Input Position menu to shift the projected image horizontally. Press ➤ to shift the image to the right; press ◀ to shift it to the left.

**Up/Down:** Select Up/Down from the Input Position menu to shift the projected image vertically. Press ➤ to shift the image upward; press ◀ to shift it downward.

**Width:** Select Width from the Input Position menu to change the projected image width. Press ➤ to increase the width; press ◀ to decrease it.

**Height:** Select Height from the Input Position menu to change the projected image height. Press ► to increase the height; press ◀ to decrease it.

**Overscan/Overscan Mode:** Overscan pushes the outside edge of the active picture area of the video signal out beyond the edge of the display area.

Some television programs are produced based on the assumption that older television sets may not display the outer edges of the broadcast picture area. Overscan effectively trims away these inactive, outer edges and enlarges the remaining portion of the image to fill the display area.

For HDTV, DVDs and other video sources, Overscan is generally not necessary or desirable.

This control defines the amount of overscan applied to the image. The range is from 0 to 20. There are two overscan modes:

- In **Crop** mode, each increment adds a mask at the top, bottom, left and right edges of the source image equal to 0.5% of the displayed horizontal resolution (1% total). A setting of 10, for example, crops the image 5% on all sides or 10% total.
- In **Zoom** mode, each increment adds a factor to the scaling of the source image so that the vertical and horizontal resolutions are 100% plus 1% increments of the size determined by the aspect ratio function. A setting of 10, for example, zooms in on the image 5% on all sides or 10% total.

Figure 4-6 illustrates the effect of each overscan mode setting.

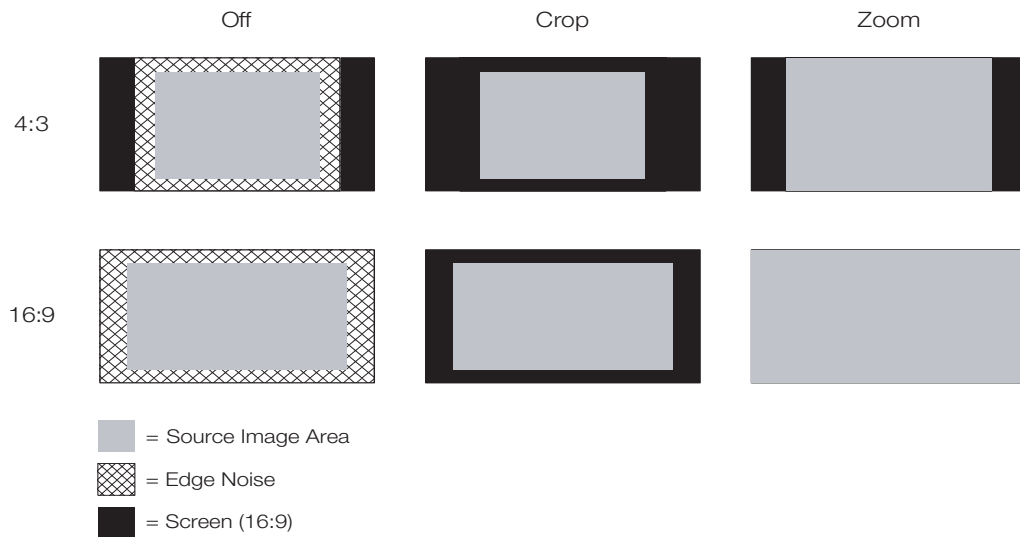

**Figure 4-6. Overscan Modes**

**Phase (RGB, Component or SCART sources):** This control adjusts the phase of the pixel sampling clock relative to the incoming signal. Adjust the phase when an RGB, Component or SCART image still shows shimmer or “noise” after Tracking has been optimized.



*Adjust the Phase after adjusting Tracking (see below).*

For best results, use a good test pattern such as a smooth gray consisting of a clear pattern of black and white pixels, or a similar “half on, half off” graphic image. Adjust the slider until the image stabilizes and each pixel is clearly defined. You may notice that you can stabilize the image at more than one point. Use either setting in such cases.

**Tracking (RGB, Component or SCART sources):** Tracking determines the frequency of the pixel sampling clock, indicated by the number of incoming pixels per line, so that all pixels generated by a particular source are sampled.

Steady flickering or several soft vertical stripes or bands across the entire image indicates poor pixel tracking. Proper pixel tracking helps ensure that the image quality is consistent across the screen, that aspect ratio is maintained and that pixel phase (see above) can be optimized.

**Memory Presets** ➤

Memory Presets		
➔	ISF Night	
	ISF Day	
	Custom 1	Save    Reset
	Custom 2	Save    Reset

For each input, the DHD Controller lets you save image quality settings as presets that you can recall at a later time. You can create up to four presets per input and display mode (resolution and frame rate).

The DHD Controller stores the following display modes in each memory preset:

- 480i
- 480p
- 576i
- 576p
- 720p/24 Hz
- 720p/25 Hz
- 720p/30 Hz
- 720p/50 Hz
- 720p/60 Hz
- 1080i/50 Hz
- 1080i/50 Hz (Australia)
- 1080i/60 Hz
- 1080p/24 Hz
- 1080p/25 Hz
- 1080p/30 Hz
- 1080p/50 Hz
- 1080p/60 Hz

Use the Memory Presets menu to recall saved image presets, or to save image settings in the “Custom 1” or “Custom 2” memory location. The currently-selected preset is indicated by a “➔” to its left; in the example shown here, ISF Night is selected.

You should save changes to any of the following settings to a preset; otherwise they will be lost when a new input source or resolution is selected:

- Brightness
- Contrast
- Color saturation
- Tint
- Sharpness
- Gamma
- Lamp Settings
- Color temperature and white balance

To select a memory preset, press ▲ or ▼ to highlight it and press **ENTER**.

To save the settings for the current input and display mode to the Custom 1 or Custom 2 memory preset, select it, press ◀ or ▶ to highlight Save and press **ENTER**.



**Note**

*To save the settings for the current input and display mode to the ISF Night or ISF Day memory preset, select Save ISF Night or Save ISF Day from the Calibration menu (refer to **Save ISF Night/Save ISF Day** on page 68).*

To reset the Custom 1 or Custom 2 memory preset to its factory-default state, select it, press ◀ or ▶ to highlight Reset and press **ENTER**.

Select Sleep Timer from the Main Menu to turn off the SC-50d/SC-60d after a specified interval. Press ▲ or ▼ to select Off, 30 Minutes, 60 Minutes, 90 Minutes, 2 Hours or 4 Hours. Then, press **ENTER**.

◀ **Sleep Timer**

Sleep Timer	
→	Off
	30 Minutes
	60 Minutes
	90 Minutes
	2 Hours
	4 Hours

**Information** ➤

Information
Signal
System
Network
Field Service
Manufacturing

**Signal / System:** Select Information from the Main Menu, then choose either Signal or System to display information about the current input signal (resolution, frequency, type et cetera) and installed firmware versions, as well as other information that uniquely identifies your DHD Controller and display device.

Should you ever need to contact Runco Technical Support, this information will help them answer your questions or resolve product performance issues.

Signal	
Input Source	HDMI 1
Signal Format	1080p/60
Input Resolution	1920x1080
Vertical Freq	59.94 Hz
Horizontal Freq	67.500 kHz
Pixel Clock	148.500 MHz
Color Space	REC709
Sync Type	Separate
Memory Preset	ISF Night

System	
Model	DHD4
Display Name	SC-50d/SC-60d
Output Resolution	1920x1080
Serial Number	00000000
Boot Version	4.0
Firmware Version	4.0
Micro Version	4.0

Network	
MAC Address	1A:2B:3C:4D:5E:6F
IP Address	192.168.0.150
Subnet Mask	255.255.0.0
Default Gateway	192.168.1.1
DHCP	Enabled
Network Status	Connected

**Network:** Select Information from the Main Menu, then choose Network to display information about the Ethernet network connection.

To enable network communication via Ethernet, refer to **IP Configuration** on page 71.

**Field Service / Manufacturing:** The Field Service and Manufacturing menus are password-protected and intended for use only by Runco service personnel and factory technicians.



Use the Calibration menu to perform advanced picture quality adjustments. **This menu should be used by ISF-certified technicians only.**

◀ **Calibration**



**Note**

*You must enter a passcode to access the Calibration menu.*

To recall the ISF Night or ISF Day settings, select “ISF Night” or “ISF Day” from the Memory Presets menu (see page 62) or use the corresponding remote control buttons.

**Display Color:** Use the Display Color settings to adjust the color balance at the DHD Controller output. These settings are saved independently for each input and display mode.

- **Gain:** Use the Gain controls to correct color imbalances in the bright areas of the image. A good way to do this is to use a test pattern consisting mostly of solid white areas, such as an 80 IRE “window” pattern. If the white areas contain traces of red (Pr), green (Y) or blue (Pr), decrease the Gain for that color.
- **Offset:** Use the Offset controls to correct color imbalances in the dark areas of the image. A good way to do this is to use a test pattern consisting mostly of dark gray areas, such as a 30 IRE “window” pattern. If the gray areas contain traces of red (Pr), green (Y) or blue (Pr), decrease the Offset for that color.
- **Gamma:** Select Gamma from the Display Color menu to choose a de-gamma curve. Used correctly, the Gamma control can improve contrast while maintaining good details for blacks and whites. If excess ambient light washes out the image and it becomes difficult or impossible to see details in dark areas, lower the gamma setting to compensate. This improves contrast while maintaining good details for blacks. Conversely, if the image is washed out and unnatural, with excessive detail in black areas, increase the setting.
- **Mode:** With the SC-50d/SC-60d, two Gamma adjustment modes are available: Simple or Advanced. The two modes are mutually exclusive; when you select the Simple mode, the Advanced selection in the Gamma menu is grayed out. Likewise, when you select Advanced, the Simple selection is grayed out.
- **Simple:** Use the Simple Gamma control to perform gamma correction at the display according to a simple power law gamma function. The value chosen here corresponds to the power variable in this equation:

$$\text{Output} = \text{Input}^{\text{Power}}$$

The DHD Controller applies this gamma curve to all three primary color channels (red, green and blue).

- **Advanced:** To select a custom gamma curve, select Mode from the Gamma menu and set it to Advanced. Then, select Advanced from the Gamma menu to select one of up to 20 pre-programmed gamma tables. Custom gamma tables provide the ability to perform complex, non-linear gamma correction on each primary color channel independently of the others.

Calibration	
<b>ISF Settings</b>	
Display Color	
Input Image	
Input Color	
Save ISF Night	
Save ISF Day	
Copy/Paste	
Output Shift	
Splash Configure	
OSD Position	

- **Lamp:** Select Lamp from the Display Color menu to adjust the projector lamp brightness.
- **Mode:** With the SC-50d/SC-60d, two lamp adjustment modes are available: Power (recommended) or Intensity. The two modes are mutually exclusive; when you select the Power mode, the Intensity selection in the Lamp menu is grayed out. Likewise, when you select Intensity, the Power selection is grayed out.
- **Power:** To supply a constant wattage to the lamp, select Mode from the Lamp menu and set it to Power. Then, select Power from the Lamp menu to set the lamp power level. You can choose to run the lamp as bright as possible (this is the default setting) or you can choose a lower setting. Generally, lower lamp output prolongs the life of the lamp, but decreases brightness.
- **Intensity:** To maintain a constant brightness level, select Mode from the Lamp menu and set it to Intensity. Then, select Intensity from the Lamp menu to specify the desired brightness level. The projector automatically adjusts the amount of power applied to the lamp as needed to maintain the desired brightness level.



**Note**

1. The “Intensity” Lamp Mode setting cannot be used with the RVR control (refer to **RVR** on page 68).

2. The Intensity value is not the actual lumen output, but rather a correlated value only— 1246 may represent 3500 lumens, for example.

- **Color Temp:** Select Color Temp from the Display Color menu to adjust the color temperature. Color temperature establishes the “color of gray” by adjusting the 75% white point to various color points.

**What are “color points?”** A “color point” is an x/y coordinate pair that defines a color’s location on the standard CIE chromaticity graph, shown in Figure 4-7. (CIE stands for “Commission Internationale de l’Éclairage” (International Commission on Illumination), the organization responsible for color measurement and management standards.)

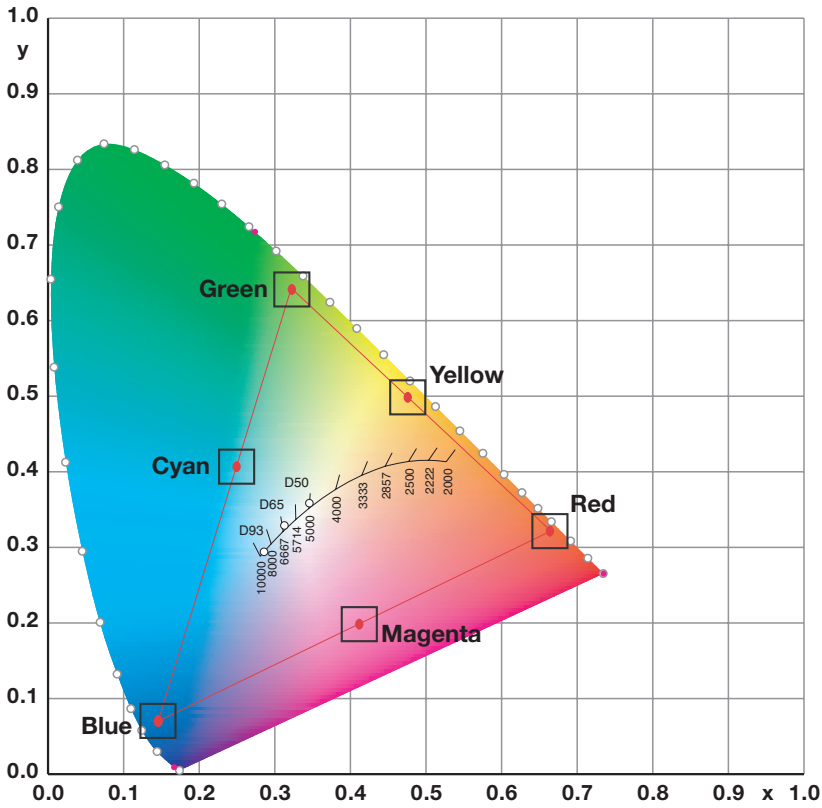

**Figure 4-7. CIE 1931 Chromaticity Diagram**

- **Simple:** Select Simple mode from the Color Temp menu to choose one of five color temperature presets: 3200K, 5500K, 6500K, 7500K and 9300K. The default setting, 6500K, is appropriate for most situations. Higher settings produce a “bluer” picture; lower ones impart a reddish hue to the image.

Table 4-2 lists the x- and y-coordinates for each color temperature preset in “Simple” mode.

**Table 4-2. Color Temperature Presets and Associated Color Points**

Color Temperature Preset	Associated x/y Values	
	x	y
3200K	0.423	0.404
5500K	0.332	0.348
6500K	0.313	0.329
7500K	0.299	0.315
9300K	0.284	0.298

- **RVR:** Use the RVR control to increase or decrease the Reflectance Volume Regulation setting. RVR lets you adjust the aperture or iris size (the physical opening through the lens; similar to an “f-stop” on a camera). Doing so allows you to optimize brightness and contrast according to the amount of ambient light in the viewing area.

Use a lower setting (larger aperture = higher brightness) for rooms with a lot of ambient light. Use a higher setting (smaller aperture = higher contrast) for more “theater-like” viewing conditions (little or no ambient light).



**Note**

*RVR can only be used with the “Power” Lamp Mode setting (refer to **Lamp** on page 66).*

**Input Image:** The Input Image controls are functionally similar to those in the Picture menu (refer to page 56), but are accessible only by entering the Calibration menu passcode.



**Note**

*The Input Image settings establish the “zero point” for the Picture menu settings, whose values represent offsets from the Input Image settings. For example, if you set Brightness to 10 in this menu, setting Brightness to 10 in the Picture menu results in an actual setting value of 20 (10+10).*

**Input Color:** The Input Color controls are similar to those in the Display Color menu (see above), but adjust the color balance of the incoming signal. These settings are also saved independently for each input and display mode.

- **Gain/Offset (HD1, HD2 and Component/SCART inputs only):** These controls operate similarly to those in the **Display Color** menu (described on page 65), but affect the Y, Pb and Pr signal components rather than the red, green and blue channels.
- **Chroma Delay:** use the Chroma Delay control to correct a mis-aligned image from a composite video source. Chroma delay in an image causes color shifts to occur to the left of the vertical edge transitions, producing artificial shadows or a “halo” effect. If necessary, adjust this setting to eliminate them.
- **Noise Filter:** To apply noise filtering to the input signal, select Noise Filter from the Input Color menu. The Noise Filter is useful for clearing up noisy images from 480i video sources.

Use the left- or right-arrow buttons to select the desired amount of noise reduction, keeping in mind that higher settings (which reduce high frequencies) may also “soften” the image.

**Save ISF Night/Save ISF Day:** Whenever you make a change to the ISF settings, you should always save it. Select Save ISF Night or Save ISF Day from the Calibration menu to do this.

**Copy/Paste:** You can copy and paste settings from one memory location to another. This gives you a convenient starting point for creating a new preset based on an existing one, to make the calibration process less time-consuming.

Copy/Paste	
Copy Settings	
Paste Settings	
Copied From:	
Input Source	HDMI 1
Signal Format	1080p/60
Memory Preset	ISF Night

For example, you can use the Copy/Paste feature to:

- Apply settings from HDMI 1 to HDMI 2, or from HD1 to HD2.
- Calibrate an input for 720p source signals, then use those settings for 1080i sources.
- Duplicate ISF Night settings for a given source and signal format and save them in the Custom 1 memory preset.

To use this feature, select Copy/Paste from the Calibration menu.

- **Copy Settings:** Select Copy Settings from the Copy/Paste menu to place the settings for the current input source, signal format (resolution and frame rate) and memory preset onto a “clipboard,” which is a temporary memory location. When you do, the message “Settings Copied” briefly appears on-screen. The Copy/Paste menu then re-appears, indicating the source of the copied settings.



**Note**

*Copied settings are not retained after a power cycle.*

- **Paste Settings:** To apply the settings on the clipboard to a different input source, signal format and/or memory preset, do **any or all** of the following:
  - Switch to another input (for example, from HD1 to HD2).
  - Change the output signal format at the source (for example, from 720p/60 to 1080i/60).
  - Switch to another Memory Preset (for example, from ISF Night to Custom 1).

Then, select Paste Settings from the Copy/Paste menu. **If you want to keep these new settings, you must save them!** (Refer to **Save ISF Night/Save ISF Day** on page 68 or **Memory Presets** on page 62.)

**Output Shift:** The controls in the Output Shift menu are similar to those in the Input Position menu, except that they change the characteristics of the output signal. These settings are saved independently **for each aspect ratio**.

**Image Alignment:** Use the controls in the Image Alignment menu to ensure proper image geometry; that is, a perfectly rectangular projected image with no keystone or pincushion. For detailed instructions, refer to **Adjusting the Image Geometry** on page 43.

**Splash Configure:** Use the Splash Configure menu to control the appearance and behavior of the “splash” screen that appears on the display upon power-up.

- **Owner Name/ISF Calibrated/ISF Other:** You can have the SC-50d/SC-60d display the owner’s name, your name, the phrase “ISF Calibrated” and/or any other string, up to 30 characters in length.

Use the up or down cursor button to select a character. Use the right and left cursor buttons to change the cursor position. Press **MENU** when you have finished entering text.

- **Splash Timer:** When you turn on the SC-50d/SC-60d, it projects a welcome screen with the Runco and ISF logos, along with the personalized information you enter as described above. Select Splash Timer from the Splash Configure menu to set the amount of time for which this screen appears. The range is from 5 to 60 seconds, in one-second increments. Press ◀ or ▶ to set the timer, then press **MENU**.
- **Splash Enable:** When you have finished customizing the splash screen, select Splash Enable from the Splash Configure menu. Then, select On and press **ENTER**.

**OSD Position:** To adjust the position of the OSD, select OSD Position from the Calibration menu and press **ENTER**.

Press ▲ or ▼ to select “Hor.” or “Ver.” Then, press ◀ or ▶ to change the position.

**Service** ➤ Use the Service menu to access advanced projector configuration settings. **This menu should be used by ISF-certified technicians only.**

Service
Test Video
Input Names
Display Device
Network
Color Space
Triggers
Miscellaneous
Sync Threshold
HDMI
Front Panel Brightness
System Reset



**Note**

*You must enter a passcode to access the Service menu.*

**Test Video:** Select Test Video from the Service Menu to access the internal test patterns on the DHD Controller. Table 4-3 lists the available test patterns and describes their suggested usage.

**Table 4-3. Test Patterns and Their Suggested Usage**

Pattern	Suggested Usage
<p><b>Color Bars 1</b></p>	Use this pattern when making color saturation and tint adjustments.
<p><b>Color Bars 2</b></p>	Use this pattern when making color saturation and tint adjustments.
<p><b>Focus</b></p>	Use this pattern when adjusting the focus.
<p><b>Grey Bars</b></p>	Use this pattern when making brightness, contrast or white balance (gain/offset) adjustments.

Press **MENU** to exit test pattern mode.

**Input Names:** You can give each input a descriptive name. For example, you may want to change the default input name to the type of source component connected to it: “VCR,” “DVD,” “Laptop” et cetera. Input names can be up to 12 characters long.

To edit an input name, select Input Names from the Service menu. Press ▲ or ▼ to select an input and press **ENTER**. Use the ▲ or ▼ buttons to change a character; press ◀ or ▶ to select a character to change. When you have finished editing the input name, press **ENTER** or **MENU**.

To restore the default input name, press ▼ repeatedly to highlight that input name in the “Restore” column. Then, press **ENTER**.

Input Names		Restore
Composite 1	1	Composite 1
Composite 2	2	Composite 2
Composite 3	3	Composite 3
Component		Component
HD 1		HD 1
HD 2		HD 2
SCART		SCART
HDMI 1		HDMI 1
HDMI 2		HDMI 2
HDMI 3		HDMI 3
HDMI 4		HDMI 4

**Display Device - Configure:** The options in the Display Device - Configure menu allow you to change the picture orientation, perform lens adjustments or access other, display-device specific functions.

- **Installation – Orientation:** Select Picture Orientation from the Display Device - Configure menu, then select Orientation to change the picture orientation to suit the method of installation (Floor Front, Floor Rear, Ceiling Front or Ceiling Rear). Or, for front-projection installations, use the **Auto** setting to have the projector automatically determine the orientation (floor or ceiling) using an internal sensor.
- **Lamp Info.:** Select Lamp Info. from the Display Device - Configure menu to see the projector serial number.
- **Diagnostics:** Select Diagnostics from the Display Device - Configure menu, then select Red, Green, Blue, Yellow, Cyan or Magenta to display only that color channel (simulating a filter of that color). This can be useful for calibration or measurement purposes.

To restore the normal picture (all colors), select White.

**Network:** The options in the Network menu allow you to configure the network communication features.

- **IP Configuration:** Select IP Configuration from the Network menu to either set the IP address, subnet mask and default gateway of the DHD Controller manually or obtain these settings automatically, from a DHCP (Dynamic Host Configuration Protocol) server. (Most broadband routers and gateways support DHCP.) You can also test the network connection from this menu.
- **DHCP:** To enable the DHCP client in the DHD Controller, select DHCP from the IP Configuration menu and set it to **On**. With this setting, the DHD Controller’s IP address, subnet mask and default gateway are assigned by the local DHCP server.

To manually configure these values, set DHCP to **Off**.



*The IP Address, Subnet Mask and Default Gateway items in the IP Configuration menu are disabled (grayed out) when DHCP is enabled.*

- **IP Address:** Select IP Address from the IP Configuration menu to manually configure the IP Address of the DHD Controller, as follows:
  1. Press ▲ or ▼ to select the first, second, third or fourth byte of the address.
  2. Press ► or ◀ to set the value of that byte. The range is from 0 to 255 inclusive.
  3. Repeat Steps 1 and 2 for all four bytes of the address.
  4. Press **MENU** when you have finished setting the address.
- **Subnet Mask:** Select Subnet Mask from the IP Configuration menu to manually configure the IP subnet mask. The procedure is similar to that for setting the IP address.
- **Default Gateway:** Select Default Gateway from the IP Configuration menu to manually configure the default IP gateway. The procedure is similar to that for setting the IP address.
- **Communication Test:** Select Communication Test from the IP Configuration menu to verify proper operation of the network communication link.

To start the test, select Start Test from the Communication Test menu. The DHD Controller displays the message “Performing Communication Test.” When the test completes, the DHD Controller displays either “Failed” (along with the error that occurred) or “Succeeded.”

- **Auto Firmware Upgrade:** Select Auto Firmware Upgrade from the Network menu to enable automatic detection of a newer version of the DHD Controller firmware. If one is found, you can configure the DHD Controller to install it automatically. These features make it easier to keep your DHD Controller firmware up-to-date.
- **Auto Check For New Firmware:** To have the DHD Controller automatically check for firmware updates at periodic intervals, select Auto Check for New Firmware from the Auto Firmware Upgrade menu and set it to **On**. If you prefer to do this manually, set it to **Off** and use the Check For New Firmware sub-menu (described below).
- **Auto Perform Upgrade:** If the “Auto Check For New Firmware” process determines that a newer firmware version than the one currently installed is available, you can have the DHD Controller automatically download and install it. To do this, select Auto Perform Upgrade from the Auto Firmware Upgrade menu and set it to **On**. The upgrade will occur the next time the DHD Controller is “power-cycled” (powered off, then on again).  
If you prefer to do this manually, set it to **Off**. The DHD Controller will ask if you want to perform the upgrade the next time it is power-cycled.
- **Check For New Firmware:** To have the DHD Controller check for new firmware on demand (and perform an upgrade if it finds a new version), select Check For New Firmware from the Auto Firmware Upgrade menu. If the DHD Controller finds a new firmware version, select **Yes** to perform the upgrade or **No** to return to the previous menu.



- **E-Mail Notification:** Select E-Mail Notification from the Network menu to specify when and to whom the DHD Controller sends error and service notification messages via e-mail.

The notification messages are in the following format:

To: [E-Mail Address; see below]  
 From: do-not-reply@runco.com  
 Subject: [Type of notification] from Runco DHD4  
 Body:

This is an automated message sent from the Runco DHD4:

Notification: [One of the following:  
 "DHD Error" / "Display Error"  
 "Periodic Service Notification"  
 "Lamp Life Notification" / "Calibration Data"]

Detailed Description: [ **If a DHD Error**, one of the following:  
 "Fan Failure 1" / "Fan Failure 2"  
 "Overtemp 1" / "Overtemp 2"  
 "Initialization Failure"

**If a Display Error**, a device-specific error message such as "Lamp Door Open"

**If a Periodic Service Notification**, the elapsed time since the last notification

**If a Lamp Life Notification**, the number of hours the lamp has been in service

**If a Calibration Data message**,  
 "See Attached File" ]

Serial Number: [DHD Controller serial number]  
 Customer Information: [From "Customer Information" sub-menu; see below]

Best Regards,

Runco International, LLC  
 1195 NW Compton Drive  
 Beaverton, OR 97006  
 1-800-237-8262

- **E-Mail Address:** To specify the destination e-mail address for error and service notifications, select E-Mail Address from the E-Mail Notification menu. The procedure is similar to that for setting the IP address (refer to **IP Configuration** on page 71). Enter up to 45 alphanumeric characters.
- **Error Notification:** To have the DHD Controller send a message to the destination e-mail address when a "DHD Error" or "Display Error" occurs, select Error Notification from the E-Mail Notification menu and set it to **On**.
- **Error Notification to Runco:** To have the DHD Controller send an e-mail message to Runco Customer Support when a "DHD Error" or "Display Error" occurs, select Error Notification to Runco from the E-Mail Notification menu and set it to **On**.

- **Periodic Service Notification:** You can have the DHD Controller send periodic reminders via e-mail to perform regular maintenance tasks. To do this:
  1. Select Periodic Service Notification from the E-Mail Notification menu.
  2. Highlight **Enable** and press **ENTER**.
  3. Highlight **On** and press **ENTER**.
  4. Press **MENU**.
  5. Highlight **Timer** and press **ENTER**.
  6. Press **▶** or **◀** to set the notification interval in months. The range is from 1 to 255 inclusive; the default is 12 months.
  7. Press **MENU**.
- **Lamp Life Notification:** To have the DHD Controller send a message to the destination e-mail address when the lamp hour counter reaches a certain threshold, select Lamp Life Notification from the E-Mail Notification menu. Then:
  1. Highlight **Enable** and press **ENTER**.
  2. Highlight **On** and press **ENTER**.
  3. Press **MENU**.
  4. Highlight **Lamp Hours** and press **ENTER**.
  5. Press **▶** or **◀** to set the notification threshold in hours. The range is from 100 to 10,000 hours; the default is 1,000 hours.
  6. Press **MENU**.
- **Customer Information:** Select Customer Information from the E-Mail Notification menu to supply this information to the DHD Controller, which includes it in all e-mail notification messages. Six lines (up to 30 characters per line) of text are provided; use them however you wish.
  1. Press **▲** or **▼** repeatedly to select a line of text to edit.
  2. Press **ENTER**.
  3. Press **▲** or **▼** repeatedly to set the highlighted character.
  4. Press **▶** (or **◀**) to select the next (or previous) character. Use the **▲** and **▼** buttons to change it.
  5. Press **ENTER** when you have finished editing that line of text.
  6. Repeat Steps 1 through 5 for each line of text you want to edit.
  7. Press **MENU** when you have finished entering customer information.
- **E-Mail Calibration Data:** To have the DHD Controller collect all calibration data, attach it to a message and send it to the destination e-mail address, select E-Mail Calibration Data from the E-Mail Notification menu. To confirm this action, select **Yes** and press **ENTER**.

To cancel and return to the previous menu, select **No**.

- **Remote Network Control:** Select Remote Network Control from the Network menu to enable or disable control of the DHD Controller via an IP connection (typically using a web browser). Set it to **On** to allow all incoming remote network connectivity. Set it to **Off** to disable any incoming network communication that was not initiated by the DHD Controller.

**Note**

*This setting has no effect on the E-Mail Notification or Auto Firmware Upgrade functions.*

**Display Device - Auto Calibration:** Auto Calibration is a process in which the projector quickly optimizes critical display parameters such as size, position and pixel tracking, based on the type of incoming video signal. Auto Calibration allows you to quickly get the image “in the ballpark” after which you can perform further calibration, if necessary.

To perform an Auto Calibration, select **Display Device** from the Service Menu. Then, select **Auto Calibration** and set it to **Yes**.

**What an “Auto Calibration” Does:** Auto Calibration sets the following parameters to their default values:

- Contrast and Brightness
- Auto Input Level (off)
- Detail (if video source)
- Filter
- Luma Delay

Auto Calibration also optimizes the following settings, based on the characteristics of the incoming signal:

- Pixel Tracking
- Pixel Phase
- Size and Blanking
- Vertical Stretch
- Position
- Input Levels

If additional fine-tuning is necessary after performing an Auto Calibration, use the controls in the Picture menu (refer to page 56) or Calibration menu (refer to page 65).

**Color Space:** Select Color Space from the Service menu to choose the color space of the source signal for HDMI, RGB, and component connections.

- The default setting, **Auto**, functions as follows:
  - **HDMI:** If the Auxiliary Video Information (AVI) infoframe contains color space and/or range data, the DHD Controller uses that information. Otherwise, for RGB sources, the DHD Controller uses the **RGB-Video** color space. For component SDTV and EDTV resolutions, **REC601** is used. For other component video resolutions, **REC709** is used.
  - **RGB:** If Hsync or Vsync signals are present, the DHD Controller uses the **RGB-PC** color space. Otherwise, **REC601** is used for SDTV and EDTV sources, and **REC709** for all other sources.
  - **Component:** For SDTV and EDTV resolutions, the DHD Controller uses the **REC601** color space. For all other resolutions, REC709 is used.

In most cases, the **Auto** setting determines the correct color space to use. If it does not, you can force the DHD Controller to use a specific color space. Choose one of the following:

- **REC709** sets the color space matrix to that defined in ITU-R BT.709.
- **REC601** sets the color space matrix to that defined in ITU-R BT.601.
- **RGB-PC** uses RGB color space and sets black at 0,0,0 RGB and white at 255,255,255 RGB, assuming an 8-bit image.
- **RGB-Video** uses RGB color space and sets black at 16,16,16 RGB and white at 235,235,235, assuming an 8-bit image, to correspond to the luminance values defined in digital component standards.

**Triggers:** Select Triggers from the Service menu to configure the 12-volt trigger outputs. You can assign one or more trigger outputs to each aspect ratio. Those triggers are then activated by selecting that aspect ratio.

**Miscellaneous:** Select Miscellaneous from the Service menu to set the following options:

- **Language:** Select Language from the Miscellaneous menu and press the up- or down-arrows to select the OSD Language (English, Français, Deutsch, Italiano, Español, Svenska, Traditional Chinese, Simplified Chinese, Português or Russian).
- **OSD Timer:** Select OSD Timer from the Miscellaneous menu to set the OSD Timer, which controls how long the menus remain on-screen after selecting them. Select from 5 to 60 seconds, in one-second increments. Or, set the timer to 0 (disabled) if you want the menus to remain on-screen indefinitely.
- **OSD Messages:** When you select a new aspect ratio, input source or memory preset, the DHD Controller briefly displays an on-screen message confirming your new selection. To prevent the display of these messages, select OSD Messages from the Miscellaneous menu to and set it to **Off**.
- **Blank Screen Color:** Select Blank Screen Color from the Miscellaneous menu to select the color that appears when no incoming signal is present. The range is from 0 to 255 inclusive for each color component (red, green and blue).
- **Sidebar Color:** Select Sidebar Color from the Miscellaneous menu to change the color of the inactive image area. The range is from 0 to 255 inclusive for each color component (red, green and blue). The inactive image area is on either side of the active image area when using the 4:3 aspect ratio.

- **Film Mode:** Use Film Mode to smooth out moving images from interlaced, standard-definition (SD) sources. In most cases, the DHD Controller detects the proper “pull-down” rate and vertical frequency. However, if your source is jittery and/or tearing you may want to enable Film Mode to ensure stable processing for that source.
- **CUE (Chroma Upsampling Error) Correction:** Some DVD players use MPEG decoders that do not correctly “upsample” the 4:2:0 format chroma information on the DVD to the 4:2:2 or 4:4:4 format required by the video encoder of the display device.

This so-called “chroma bug” sometimes causes streaky or spiky horizontal lines running through the chroma channel. It is most noticeable in static, interlaced scenes and on diagonal edges (especially red ones). Set CUE to **On** to correct this issue.

- **Remote Code:** Select Remote Code from the Miscellaneous menu to set the infrared (IR) code set to which the DHD Controller will respond. By default, it is set to 17. You can change this setting if either:
  - Another device in the theater (a DVD player, for example) is responding to commands from the DHD Controller remote control (Figure 2-5) in ways that are unpredictable or undesirable.
  - You have multiple DHD Controllers and want to control them independently, as opposed to broadcasting commands from a single remote to all of them. In this scenario, you can use multiple remotes programmed to use different IR codes. Or, you can use a single remote and change the IR code as needed to address a specific DHD Controller.



**Tip**

*Use the DHD Controller front-panel keypad to change the IR code to which the controller will respond. Then, change the code sent by the remote to match as described below.*

When you change a remote code on the DHD Controller, you must re-program the DHD Controller remote control to send that same code. To do this:

1. Press and hold the **LIGHT** button on the remote control for approximately three seconds, or until the LED on the remote lights solid red.
2. Enter a new two-digit code between 00 and 31 inclusive. Include a leading zero for single-digit codes; for example, enter 9 as “09.”
3. The LED turns off to confirm the code change. If you enter an invalid code, the LED flashes for three or four seconds. Try again, entering a valid code.



**Sync Threshold:** Select Sync Threshold to adjust the threshold at which negative pulses on the component video green/luma channel are interpreted to be sync pulses.

Sync Threshold adjustment is occasionally necessary when a DVD player or HDTV source signal drops “below black” (for example, during scenes with explosions or when subtitles are present) and causes the projector to temporarily lose sync. If the sync level from the source is persistently too low, the display device won’t sync with the source at all.

The range is from 0 (approximately 60 millivolts (mV)) to 15 (approximately 300 mV).

**HDMI:** Select HDMI from the Service menu to set the following options affecting communication between HDMI sources, the DHD Controller and the SC-50d/SC-60d.

- **HDMI EDID Extension:** Extended display identification data (EDID) is a data structure provided by a display device to describe its capabilities to a graphics card. It is what enables a modern personal computer to know what kind of monitor is connected.

Some modern display devices provide more information via EDID than others, in the form of “extensions.” Some computer graphics cards do recognize or properly interpret this extended EDID information.

Select HDMI EDID Extension from the HDMI menu to specify whether or not the EDID extensions from the display device are passed through to the 3Dimension Processor and to the sources connected to the HDMI 1, HDMI 2, HDMI 3 or HDMI 4 inputs. By default, the extensions are on. Change these settings only if HDMI EDID incompatibility issues arise.

- **Audio Format:** Select Audio Format from the HDMI menu to choose an option for routing the audio signal from an HDMI source. With the SC-50d/SC-60d, the recommended setting is **HDMI Out (Audio Only)**. (This is also the default setting.)
- **CEC:** This control chooses whether or not the DHD Controller responds to HDMI CEC control messages from a disc player, set-top box or other HDMI source.

The default setting is **On**. For more information about CEC, refer to **Using HDMI CEC Messages** on page 94.



**Note**

*The DHD Controller does not transmit HDMI CEC control messages from the “HDMI Audio Out” connector, regardless of the CEC setting.*

**Front Panel Brightness:** Select Front Panel Brightness from the Service menu to adjust the brightness of the front-panel LED and LCD status indicators.

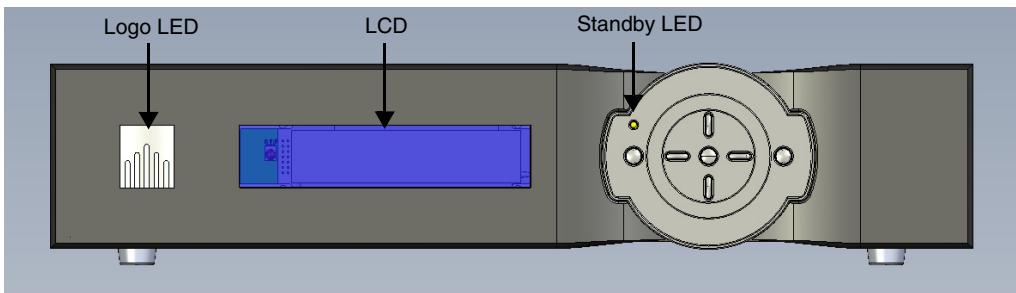

- **Logo LED:** Select Logo LED from the Front Panel Brightness menu to adjust the brightness of the large, illuminated logo on the left side of the display. The range is from 0 (off) to 31.

**Note**

*During a firmware upgrade, this LED lights at full brightness regardless of the Logo LED setting.*

- **Standby LED:** Select Standby LED from the Front Panel Brightness menu to change the behavior of the front-panel STANDBY indicator LED. When set to ON, the LED lights amber when the system is in standby mode; otherwise, it is off. When set to OFF, the LED is always off.

**Note**

*During a firmware upgrade, this LED lights at full brightness regardless of the Standby LED setting.*

- **LCD:** Select LCD from the Front Panel Brightness menu to adjust the brightness of the front-panel LCD. The range is from 0 (off) to 4.

**Auto Power Off:** Select Auto Power Off from the Service menu to have the SC-50d/SC-60d turn itself off after a period of inactivity (no source signal present).

- **Enable:** By default, Auto Power Off is disabled. To enable it, select Enable from the Auto Power Off sub-menu and set it to On.
- **Hours:** The default time-out period is eight (8) hours; the range is from 1 to 24 hours.

**System Reset:** To reset ALL controller settings (including image settings) back to their factory defaults, choose System Reset from the Service menu.

A confirmation message appears. Select Yes to continue with the reset or select No to cancel.

**Caution**

***This action is not undoable. Proceed with caution!*** Before you perform a System Reset, save your "Custom" Memory Presets (page 62) and ISF Day/Night Memory Presets (page 68).

**Notes:**



## 5. Maintenance and Troubleshooting

The lamp should be replaced when it reaches the end of its life (typically 2,000 hours), or sooner if a noticeable degradation in brightness occurs.

Keep track of the number of hours the lamp has been in use and be aware of any changes to brightness. These indicators will help you effectively maintain operation of the projector. To find out how long the currently-installed lamp has been in service, select Lamp Info. from the Display Device - Configure menu (available by selecting **Service -> Display Device -> Configure -> Lamp Info**, in sequence).

**For lamp or filter replacement, please contact your nearest Runco authorized service center or Runco dealer. Do not attempt to replace the lamp yourself!**

1. Turn off the projector and unplug the power cord. Allow the projector to cool down for approximately 15 minutes prior to removing the lamp assembly for replacement.
2. Remove the four screws securing the Left (Exhaust) Side Panel (see Figure 2-1) to the projector. Then, remove the panel.
3. **To open the lamp compartment cover:** Using a Phillips screwdriver, turn the captive screw on the lamp compartment cover counter-clockwise to access the lamp compartment (see Figure 5-1).

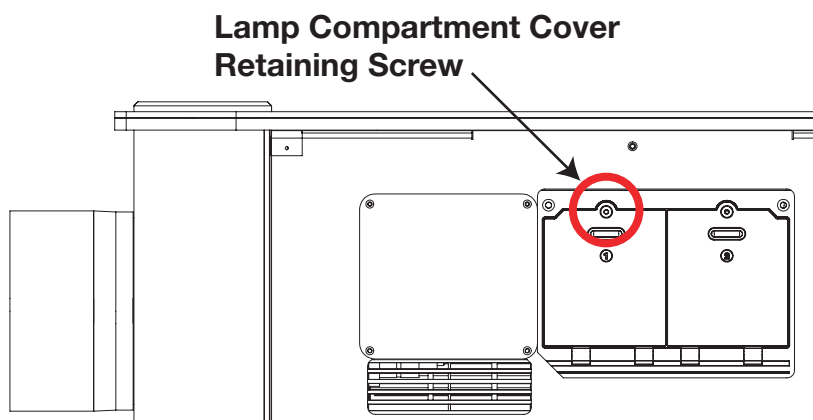

**Figure 5-1. Opening the Lamp Door**

4. Remove the old lamp.
  - a Unscrew the three (3) captive screws securing the lamp using a #1 Phillips screwdriver.
  - b Carefully remove the lamp from the projector. Place the old lamp in a location where it cannot fall or be bumped.



### **WARNING**

*Handle lamps with extreme caution. Dispose of lamps according to safety regulations for your area. Discard the lamp using safe disposal/recycling practices or contact your Runco dealer for a possible re-lamping program.*

5. Install the new lamp:
  - a Take care to align the new lamp properly in the correct orientation inside the lamp compartment.
  - b Press firmly on the lamp to properly seat it.
  - c Secure the lamp by tightening the three (3) captive screws.
6. Close the lamp compartment cover and tighten the captive screw.



**Note**

*The lamp will automatically turn on again when the cover is closed.*

7. Re-attach the Left (Exhaust) Side Panel to the projector.

Table 5-1 provides some general guidelines for troubleshooting problems you may encounter with the SC-50d/SC-60d. If the suggested solutions fail to resolve the problem or if you encounter an issue not described here, please contact Runco Technical Support.

**Table 5-1. Troubleshooting Chart**

Symptom	Possible Cause(s)	Solution
The projector does not turn on.	<ul style="list-style-type: none"> <li>The SC-50d/SC-60d is not plugged in and switched on, or the AC outlet is not active.</li> <li>The DHD Controller is not plugged in and switched on, or the AC outlet is not active.</li> <li>The remote control batteries have run out.</li> <li>The serial connection from the DHD Controller to the SC-50d/SC-60d is incorrect.</li> </ul>	<ul style="list-style-type: none"> <li>Ensure that the SC-50d/SC-60d is plugged in and switched on, and that the AC outlet is active.</li> <li>Ensure that the DHD Controller is plugged in and switched on, and that the AC outlet is active.</li> <li>Replace the batteries.</li> <li>Ensure that the RS-232 output from the DHD Controller is properly connected to the RS-232C input on the SC-50d/SC-60d (see Figure 3-10).</li> </ul>
The projector and DHD Controller are both on, but there is no picture and on-screen menus do not appear.	<ul style="list-style-type: none"> <li>Lens cover is on or shutter is closed.</li> <li>Lamp failed to ignite.</li> <li>Faulty or incorrect video connection between the DHD Controller and the SC-50d/SC-60d.</li> </ul>	<ul style="list-style-type: none"> <li>Ensure that the lens cover is off and the shutter is open.</li> <li>Ensure that the lamp door is closed. If it is and the problem persists, replace the lamp.</li> <li>Ensure that the HDMI output from the DHD Controller is properly connected to the <b>Slot 2</b> DVI-I input on the SC-50d/SC-60d (see Figure 3-10).</li> </ul>
The display is on and menus appear, but there is no picture.	<ul style="list-style-type: none"> <li>Incorrect source selection.</li> <li>Source component is not turned on.</li> <li>Source component is connected incorrectly or not at all.</li> </ul>	<ul style="list-style-type: none"> <li>Select the correct source.</li> <li>Turn on the source component.</li> <li>Check connections from source component to DHD Controller.</li> </ul>
A projected image from a DVD is split or otherwise scrambled.	<ul style="list-style-type: none"> <li>DVD player is connected to the Component input and set to progressive scan mode.</li> </ul>	<ul style="list-style-type: none"> <li>Turn off progressive scan on the DVD player. Or, connect the DVD player to the HD1 or HD2 input.</li> </ul>
Image geometry is incorrect.	<ul style="list-style-type: none"> <li>Incorrect aspect ratio selection.</li> </ul>	<ul style="list-style-type: none"> <li>Select a different aspect ratio.</li> </ul>

## 5.2 Troubleshooting Tips

**Table 5-1. Troubleshooting Chart (continued)**

Symptom	Possible Cause(s)	Solution
The display is jittery or unstable.	<ul style="list-style-type: none"> <li>Poor-quality or improperly connected source.</li> <li>The horizontal or vertical scan frequency of the input signal may be out of range for the projector.</li> </ul>	<ul style="list-style-type: none"> <li>Ensure that the source is properly connected and of adequate quality for detection.</li> <li>Correct at the source.</li> </ul>
Image is too bright and/or lacks definition in the bright areas of the image.	<ul style="list-style-type: none"> <li>Contrast is set too high.</li> </ul>	<ul style="list-style-type: none"> <li>Lower the contrast setting.</li> </ul>
Image appears “washed out” and/or dark areas appear too bright.	<ul style="list-style-type: none"> <li>Brightness is set too high.</li> </ul>	<ul style="list-style-type: none"> <li>Lower the brightness setting.</li> </ul>
Colors in the image are swapped; for example, reds appear blue or vice versa.	<ul style="list-style-type: none"> <li>The Red/Pr, Green/Y or Blue/Pb outputs from the source are connected to the wrong inputs on the DHD Controller.</li> </ul>	<ul style="list-style-type: none"> <li>Ensure that the source outputs are connected to the correct DHD Controller input.</li> </ul>
The display freezes suddenly.	<ul style="list-style-type: none"> <li>Excessive voltage noise on the AC or ground input has interrupted the projector’s ability to lock on to a signal.</li> </ul>	<ul style="list-style-type: none"> <li>Power down the projector and disconnect from AC. Then, plug in again and power up as usual.</li> </ul>
The projector will not turn back on after it was powered down, or the image disappears during operation.	<ul style="list-style-type: none"> <li>The projector will not turn on for two minutes after power-down, to protect the lamp.</li> <li>The lamp has failed.</li> </ul>	<ul style="list-style-type: none"> <li>Wait until the LED at the front of the DHD Controller turns red.</li> <li>Replace the lamp.</li> </ul>
AutoScope lens motor does not work.	<ul style="list-style-type: none"> <li>The motor is not plugged in or the AC outlet is not active.</li> <li>The motor is not connected to a trigger output on the DHD Controller.</li> <li>Incorrect trigger assignment.</li> </ul>	<ul style="list-style-type: none"> <li>Ensure that the motor is plugged in and that the AC outlet is active.</li> <li>Check the trigger connection between the lens motor and DHD Controller (Figure 3-17).</li> <li>Correct the trigger assignment (refer to <b>Installing and Adjusting the CineWide Anamorphic Lens</b> on page 45).</li> </ul>

## 6. External Control

In addition to using the DHD Controller front-panel keypad or remote control unit, there are three methods of controlling the SC-50d/SC-60d and DHD Controller externally:

- Using a serial (RS-232) link to send ASCII commands and receive responses to those commands.
- Using discrete infrared (IR) codes to program a third-party remote control unit.
- Using an HDMI connection to send Consumer Electronics Control (CEC) commands from a BD player or other source component that supports CEC.

The following sections describe these methods.

The DHD Controller uses a simple text-based control protocol to take requests from control devices and to provide responses to such devices. This section describes how to send control messages over a serial link between the DHD Controller and an automation/control system or a PC running terminal emulation software.

Connect your control system or PC to the RS-232 input of the DHD Controller as shown in Figure 3-17.

Configure the RS-232 controller or PC serial port as follows: no parity, 8 data bits, 1 stop bit and no flow control. Set the baud rate to 19200, to match that of the DHD Controller RS-232 port.

Serial commands to the DHD Controller take the following form:

- Commands are not case-sensitive.
- For a single command that takes no parameters, type the command followed by a carriage return; for example, to set the aspect ratio to Letterbox, type `LETTERBOX <Enter>`.
- For a single command that takes a parameter, type the command, a space or a comma and the desired value followed by a carriage return; for example, to set the brightness to -10, type `BRIGHTNESS -10 <Enter>` or `BRIGHTNESS,-10 <Enter>`.
- You can also send a string of multiple commands on a single line, separated by commas. For example, `COMPOSITE,BRIGHTNESS 50,16:9 <Enter>` switches to the Composite video input, sets the brightness to 50 and sets the aspect ratio to 16:9. Command strings can be up to 255 characters long.



### Note

Avoid combining the `ON` or `POWER 1` commands with other commands on a single line. After sending `ON` or `POWER 1`, allow at least five (5) seconds for the DHD Controller to power up. If you have enabled the ISF splash screen (refer to **Splash Configure** on page 69), allow 15 seconds for the DHD Controller to power up.

Once it does, it will accept and properly execute multiple serial commands.

### 6.1 Serial Communications

#### ◀ RS-232 Connection and Port Configuration

#### ◀ Serial Command Syntax

Table 6-1 lists the RS-232 command set. The “Parameter (min/max)” column shows the valid parameter ranges, or “NA” for commands that take no parameters.

When you enter a valid command, the DHD Controller executes it and acknowledges it with a plus sign on the command line (+ >). When you enter an invalid command – one that is misspelled or followed by values outside the valid range for that command – the DHD Controller ignores it and returns a minus sign (- >).

**Table 6-1. Serial Commands**

Command	Parameter (min/max)	Value Stored?	Description
<b>Power On/Off Commands</b>			
OFF	NA	NA	Turns projector off
ON	NA	NA	Turns projector on
POWER	0/1	NA	Turns projector on and off
POWER?	NA	NA	Returns power status
<b>Input Selection Commands</b>			
COMPONENT	NA	YES	Selects the Component input
COMPOSITE or COMPOSITE1	NA	YES	Selects the Composite 1 video input
COMPOSITE2	NA	YES	Selects the Composite 2 video input
COMPOSITE3	NA	YES	Selects the Composite 3 video input
HDMI1	NA	YES	Selects the HDMI 1 input
HDMI2	NA	YES	Selects the HDMI 2 input
HDMI3	NA	YES	Selects the HDMI 3 input
HDMI4	NA	YES	Selects the HDMI 4 input
HD1	NA	YES	Selects the RGB HD 1 input
HD2	NA	YES	Selects the RGB HD 2 input
INPUT?	NA	NA	Returns active input
SCART	NA	YES	Selects the SCART input

**Table 6-1. Serial Commands (continued)**

Command	Parameter (min/max)	Value Stored?	Description
<b>Aspect Ratio Commands</b>			
16:9	NA	YES	Selects the 16:9 aspect ratio
4:3	NA	YES	Selects the 4:3 aspect ratio
ASPECT?	NA	NA	Returns current aspect ratio
CINEMA	NA	YES	Selects the Cinema aspect ratio
LETTERBOX	NA	YES	Selects the Letterbox aspect ratio
NATIVE	NA	YES	Selects the Native aspect ratio
VIRTUALWIDE	NA	YES	Selects the VirtualWide aspect ratio
VIRTUALCINEMA	NA	YES	Selects the Virtual Cinema aspect ratio
<b>Picture Adjust Commands</b>			
BRIGHTNESS	-50/50	YES	Sets a value for brightness
BRIGHTNESS?	NA	NA	Returns brightness setting value
CHROMADELAY	-7/7	YES	Sets a value for input color chroma delay
CHROMADELAY?	NA	NA	Returns input color chroma delay setting
COLOR	-50/50	YES	Sets a value for color
COLOR?	NA	NA	Returns color setting value
CONTRAST	-50/50	YES	Sets a value for contrast
CONTRAST?	NA	NA	Returns contrast setting value
FILMMODE	0/1	YES	Sets Film Mode off (0) or on (1)
FILMMODE?	NA	NA	Returns Film Mode setting (0 = off; 1 = on)
FILTER	0/10	YES	Sets a value for input color noise filter
FILTER?	NA	NA	Returns input color noise filter setting
PHASE	0/31	YES	Adjusts phase
PHASE?	NA	NA	Returns phase setting value
SHARPNESS	-50/50	YES	Sets a value for sharpness
SHARPNESS?	NA	NA	Returns sharpness setting value
TINT	-50/50	YES	Sets a value for tint
TINT?	NA	NA	Returns tint setting value

**Table 6-1. Serial Commands (continued)**

Command	Parameter (min/max)	Value Stored?	Description
<b>Image Preset Commands</b>			
CUSTOM1	NA	YES	Loads "Custom 1" image preset
CUSTOM2	NA	YES	Loads "Custom 2" image preset
DAY	NA	YES	Loads "ISF Day" image preset
NIGHT	NA	YES	Loads "ISF Night" image preset
PRESET?	NA	NA	Returns currently-selected preset (ISF Day, ISF Night, Custom 1 or Custom 2)
<b>Input Position Commands</b>			
IHEIGHT	0/20	YES	Sets the value for input height
IHEIGHT?	NA	NA	Returns input height value
IHPOS	-50/50	YES	Sets a value for horizontal input position
IHPOS?	NA	NA	Returns input horizontal position value
IVPOS	-50/50	YES	Sets a value for vertical input position
IVPOS?	NA	NA	Returns input vertical position value
IWIDTH	0/50	YES	Sets the value for input width
IWIDTH?	NA	NA	Returns input horizontal width value
OVERSCAN	0/20	YES	Sets the overscan percentage
OVERSCAN?	NA	NA	Returns overscan percentage
OVERSCANMODE	0/1	YES	Sets the overscan mode (0=zoom; 1=crop)
OVERSCANMODE?	NA	NA	Returns the overscan mode (0=zoom; 1=crop)
<b>Output Shift Commands</b>			
OHEIGHT	-50/50	YES	Sets the value for output height
OHEIGHT?	NA	NA	Returns output height value
OHPOS	-50/50	YES	Sets the value for output horizontal position
OHPOS?	NA	NA	Returns output horizontal position value
OVPOS	-50/50	YES	Sets the value for output vertical position
OVPOS?	NA	NA	Returns output vertical position value
OWIDTH	-50/50	YES	Sets the value for output width
OWIDTH?	NA	NA	Returns output horizontal width value



**Table 6-1. Serial Commands (continued)**

Command	Parameter (min/max)	Value Stored?	Description
<b>Sleep Timer Commands</b>			
SLEEPTMR?	NA	NA	Returns sleep timer setting
STOFF	NA	YES	Sets the sleep timer to Off
ST30MIN	NA	YES	Sets the sleep timer to 30 minutes
ST60MIN	NA	YES	Sets the sleep timer to 60 minutes
ST90MIN	NA	YES	Sets the sleep timer to 90 minutes
ST2HRS	NA	YES	Sets the sleep timer to 2 hours
ST4HRS	NA	YES	Sets the sleep timer to 4 hours
<b>Miscellaneous Commands</b>			
DISPLAY?	NA	NA	Returns display device input source value, as follows: 1 = Auto 51 = SC-50d/SC-60d
INRES?	NA	NA	Returns input resolution
MACADDR?	NA	NA	Returns DHD Controller MAC address
MODEL?	NA	NA	Returns product model name
OUTRES?	NA	NA	Returns output resolution
SERNUM?	NA	NA	Returns DHD Controller serial number
SWVER?	NA	NA	Returns software version number
SYSSTATE?	0/4	NA	Returns current system state 0 = Off 1 = Initializing 2 = On 3 = Powering Down 4 = Error
TRIGGER	1/3	YES	Assigns trigger to currently-selected aspect ratio
<p>The following serial commands are meant to emulate buttons on the remote control or DHD Controller front panel. Each button has its own serial command, so effectively it is as if you were using the IR remote only you'll be doing so via serial commands. These commands provide active OSD responses just like the IR remote.</p>			
DOWN	NA	NA	Down-Arrow (▼) key
ENTER	NA	NA	<b>ENTER</b> key
EXIT	NA	NA	<b>EXIT</b> key
LEFT	NA	NA	Left-Arrow (◀) key
MENU	NA	NA	<b>MENU</b>

**Table 6-1. Serial Commands (continued)**

Command	Parameter (min/max)	Value Stored?	Description
RIGHT	NA	NA	Right-Arrow (▶) key
UP	NA	NA	Up-Arrow (▲) key

## 6.2 Using Discrete IR Codes

The DHD Controller accepts commands in the form of IR signals that conform to the Phillips RC5 protocol. Each DHD Controller remote control button has an RC5 control code associated with it.

You can use these codes to program a third-party, “universal” remote control unit to work with the DHD Controller. These third-party products usually come with a computer software application for this purpose. For more information, consult the documentation provided with the remote control unit.

### **IR Command Protocol** ➤

The IR control codes have the following characteristics:

- Each code consists of 14 bits:
  - Two (2) **start bits** (always 1);
  - A **toggle bit**. This bit is inverted every time a key is released and pressed again. This allows the DHD Controller to distinguish between a button that remains down and one that is pressed repeatedly.
  - Five (5) **address bits**. The default address is **17** (binary 10001). To change it, select Remote Code from the Miscellaneous menu (in the Service menu) and follow the steps given on page 77.
  - Six (6) **data bits**.
- The carrier frequency is 36 kHz, with the modulated pulses having a 25% duty cycle.
- Commands are sent at a maximum rate of 9 Hz.

For example, here is the RC5 control code for the **ON** button on the DHD Controller remote control unit (assuming the default address is used):

With Toggle Bit = 0														
Hex	3		4				4				1			
Binary	1	1	0	1	0	0	0	1	0	0	0	0	0	1
With Toggle Bit = 1														
Hex	3		C				4				1			
Binary	1	1	1	1	0	0	0	1	0	0	0	0	0	1
Function	Start Bits		Toggle Bit	Address				Command						

Figure 6-1 shows the pulse train for this command (with the toggle bit set to zero).

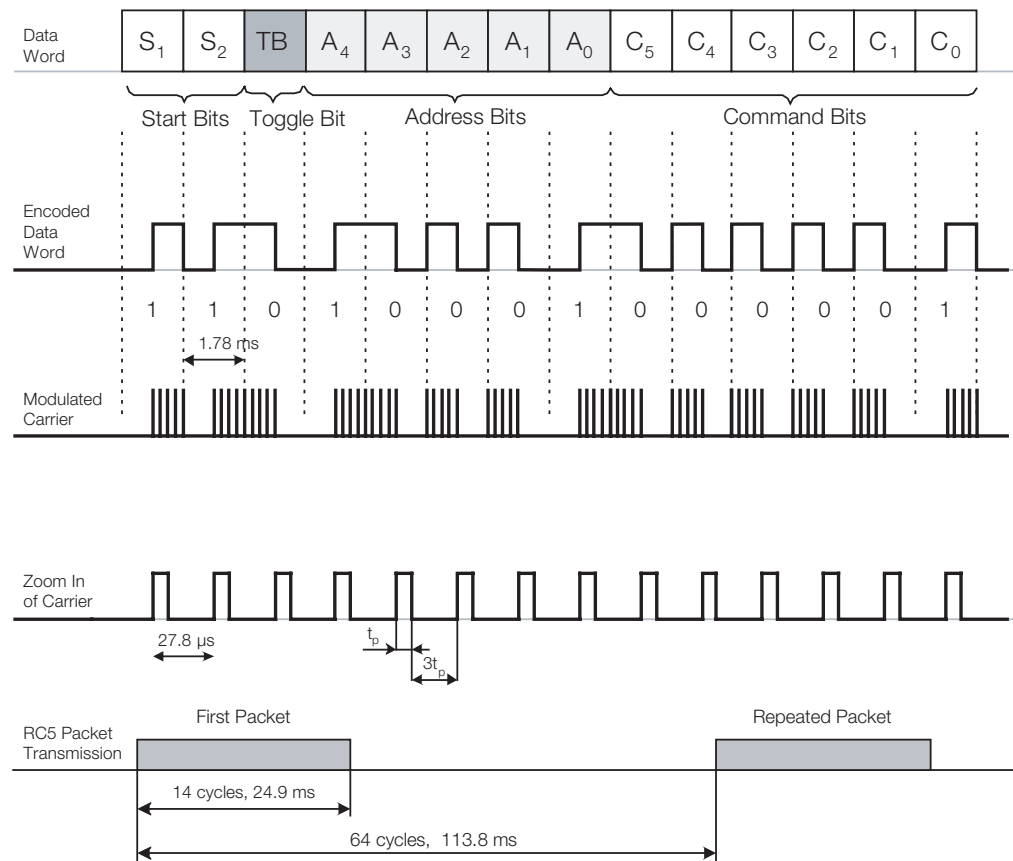

**Figure 6-1. RC5 Message Format**

**IR Command List** ➤ Table 6-2 lists the RC5 control codes for the DHD Controller.

**Table 6-2. RC5 Control Codes for the DHD Controller**

Remote Control Button Name	RC5 Data from Remote Control (Note)	RC5 Data with Toggle Bit = 1 (Note)	Description
16:9	0x3449	0x3C49	16:9 aspect ratio
4:3	0x344A	0x3C4A	4:3 aspect ratio
CINEMA	0x346C	0x3C6C	Cinema aspect ratio
COMP	0x344E	0x3C4E	Component video input
CUST 1	0x3472	0x3C72	Custom 1 memory preset
CUST 2	0x3473	0x3C73	Custom 2 memory preset
DOWN	0x3446	0x3C46	Down-Arrow (▼)
ENTER	0x3444	0x3C44	<b>ENTER</b>
EXIT	0x3474	0x3C74	<b>EXIT</b>
HD 1	0x3451	0x3C51	HD1 video input
HD 2	0x3452	0x3C52	HD2 video input
HDMI 1	0x3453	0x3C53	HDMI1 video input
HDMI 2	0x3454	0x3C54	HDMI2 video input
HDMI 3	0x3455	0x3C56	HDMI3 video input
HDMI 4	0x3456	0x3C56	HDMI4 video input
ISF DAY	0x3471	0x3C71	ISF Day memory preset
ISF NT	0x3470	0x3C70	ISF Night memory preset
LEFT	0x3447	0x3C47	Left-Arrow (◀)
LET BOX	0x344B	0x3C4B	Letterbox aspect ratio
MENU	0x3443	0x3C43	<b>MENU</b>
NATIVE	0x346E	0x3C6E	Native aspect ratio
OFF	0x3442	0x3C42	Power off
ON	0x3441	0x3C41	Power on
RIGHT	0x3448	0x3C48	Right-Arrow (▶)
SCART	0x3457	0x3C57	SCART video input
STOFF	0x3460	0x3C60	Sets the sleep timer to Off
ST30MIN	0x3461	0x3C61	Sets the sleep timer to 30 minutes

**Note:** These codes assume that the default address of 17 is used. If you change it to something other than 17, you will need to modify these codes accordingly.

**Table 6-2. RC5 Control Codes for the DHD Controller (continued)**

Remote Control Button Name	RC5 Data from Remote Control (Note)	RC5 Data with Toggle Bit = 1 (Note)	Description
ST60MIN	0x3462	0x3C62	Sets the sleep timer to 60 minutes
ST90MIN	0x3463	0x3C63	Sets the sleep timer to 90 minutes
ST2HRS	0x3464	0x3C64	Sets the sleep timer to 2 hours
ST4HRS	0x3465	0x3C65	Sets the sleep timer to 4 hours
UP	0x3445	0x3C45	Up-Arrow (▲)
VID 1	0x344D	0x3C4D	Composite video input 1
VID 2	0x3458	0x3C58	Composite video input 2
VID 3	0x3459	0x3C59	Composite video input 3
V-CINE	0x346D	0x3C6D	Virtual Cinema aspect ratio
V-WIDE	0x344C	0x3C4C	VirtualWide aspect ratio

**Note:** These codes assume that the default address of 17 is used. If you change it to something other than 17, you will need to modify these codes accordingly.

### 6.3 Using HDMI CEC Messages

The DHD Controller accepts and can respond to CEC command messages from a disc player, satellite receiver or DVR/set-top box via an HDMI connection. Using CEC, the DHD Controller can perform the following actions:

- Turn itself and the display device on and select the correct input when the source component initiates playback of a disc or recorded program.
- Turn the source component on when you switch to its corresponding input on the DHD Controller.
- Turn the source component off when the DHD Controller is turned off (unless the source component is in playback mode).
- Change its OSD language when a similar change is made at the source.

To use CEC, connect your CEC-compatible sources to the HDMI inputs on the SC-50d/SC-60d. Set the CEC option to **On** (refer to **CEC** on page 78). Additional steps may be needed to enable CEC at the source. Refer to the documentation for your source device for more information.

**CEC Command List** ➤ Table 6-3 lists the CEC commands supported by the DHD Controller.

**Table 6-3. CEC Commands Supported by the DHD Controller**

Opcode	Value	Supported? (√ = Yes, – = No)	
		Initiator	Follower
Feature Abort	0x00	√	√
Standby	0x36	√	√
Routing Change	0x80	√	√
Routing Information	0x81	√	√
Active Source	0x82	√	√
Request Active Source	0x85	√	√
Device Vendor ID	0x87	√	√
Give Device Vendor ID	0x8C	√	√
Vendor Command With ID	0xA0	√	√
Polling Message	N/A	√	√
Text View On	0x0D	√	–
Report Physical Address	0x84	√	–
Inactive Source	0x9D	√	–
CEC Version	0x9E	√	–
Set OSD Name	0x47	√	–
Menu Status	0x8E	√	–
Report Power Status	0x90	√	–
Set Menu Language	0x32	–	√

**Table 6-3. CEC Commands Supported by the DHD Controller (continued)**

Opcode	Value	Supported? (√ = Yes, – = No)	
		Initiator	Follower
Give Physical Address	0x83	–	√
Set Stream Path	0x86	–	√
Get CEC Version	0x9F	–	√
Abort Message	0xFF	–	√
User Control Pressed	0x44	–	√
User Control Released	0x45	–	√
Give OSD Name	0x46	–	√
Menu Request	0x8D	–	√
Give Device Power Status	0x8F	–	√

**Note**

*The DHD Controller does not transmit HDMI CEC control messages from the “HDMI Audio Out” connector.*

**Notes:**



# 7. Specifications

Table 7-1 lists the SC-50d/SC-60d projector specifications.

**Table 7-1. SC-50d/SC-60d Projector Specifications**

<b>Projector Type:</b>	Texas Instruments Digital Light Processing™ (DLP) dual imaging system, SuperOnyx™ DMD™
<b>Native Resolution:</b>	Full HD 1920 x 1080 (1080p)
<b>Lamp Life:</b>	SC-50d - 2,000 hours typical SC-60d - 1,300 hours typical
<b>Aspect Ratios:</b>	4:3, Letterbox, 16:9, VirtualWide, Cinema, Virtual Cinema, Native
<b>DTV Compatibility:</b>	Refer to Table 7-2
<b>Picture Size (16:9 Screen), SC-50d:</b>	Recommended Width: 100 - 132 in. Maximum Width: 264 in.
<b>Picture Size (16:9 Screen), SC-60d:</b>	Recommended Width: 120 - 198 in. Maximum Width: 420 in.
<b>Processing:</b>	Runco DHD4 Processor with ViVix IV™ technology and BRiC (Backup, Recovery and Clone) tool
<b>Control Options:</b>	<ul style="list-style-type: none"> <li>• Serial commands via RS-232</li> <li>• Discrete infrared (IR) remote</li> <li>• Consumer Electronics Control (CEC) protocol support via HDMI</li> <li>• Ethernet</li> </ul>
<b>Inputs:</b>	Refer to Table 7-2
<b>Video Standards:</b>	NTSC, PAL, SECAM, CEA-861D
<b>Calibration:</b>	ISF Certified Calibration Configuration
<b>Throw Distance (Factor x Screen Width):</b>	Refer to Table 3-3
<b>Horizontal &amp; Vertical Offset:</b>	Refer to Table 3-4
<b>Light Output:</b>	<p><b>SC-50d:</b> CSMS Specifications* – Private Cinema Calibration: 3,471 ANSI Lumens; 126 Foot-Lamberts (fL) Uncalibrated: 6,000 ANSI Lumens</p> <p><b>SC-60d:</b> CSMS Specifications* – Private Cinema Calibration: 5,785 ANSI Lumens; 210 Foot-Lamberts (fL) Uncalibrated: 10,000 ANSI Lumens</p> <p>*Measured on a 1.0 gain, 84" wide 16:9 screen</p>
<b>Contrast Ratio:</b>	CSMS* Contrast Ratio: >500:1 (ANSI)

## 7.1 SC-50d/SC-60d Projector Specifications

**Table 7-1. SC-50d/SC-60d Projector Specifications (continued)**

<b>Illumination System:</b>	200W (SC-50d) or 350W (SC-60d) HPM lamp
<b>Power Requirements:</b>	100 VAC to 240 VAC +/- 10% @ 50/60Hz
<b>Power Consumption:</b>	<b>SC-50d</b> - 1135W maximum; Current - 11.4A @100V <b>SC-60d</b> - 1320W maximum; Current - 13.2A @100V
<b>Operating Temperature:</b>	10°C to 40°C, up to 7,500' altitude 10°C to 35°C, 7,500' to 10,000' altitude
<b>Operating Humidity:</b>	10 - 80% humidity (non-condensing)
<b>Dimensions:</b>	See Figure 7-1 and Figure 7-2
<b>Weight (without lens):</b>	135 lbs. (61.24 kg)
<b>Regulatory Approvals:</b>	FCC Part 15, Subpart B Class A, UL 60950, IEC60950, RoHS
<b>Limited Warranty:</b>	Two (2)-year PremierCare™ warranty; lamp warranty 1000 hours or (6) six months, whichever comes first (US and Canada only)

**Specifications are subject to change without notice.**

Table 7-2 lists the DHD Controller specifications.

**Table 7-2. DHD Controller Specifications**

<b>Aspect Ratios:</b>	4:3, Letterbox, 16:9, VirtualWide, Cinema, Virtual Cinema, Native
<b>Video Standards:</b>	<ul style="list-style-type: none"> <li>• HDMI and DVI with HDCP for digital video</li> <li>• Component and RGB HDTV (1080p, 1080i, 720p)</li> <li>• Component and RGB EDTV (576p, 480p)</li> <li>• Component and Composite SDTV (576i, 480i)</li> <li>• RGB SCART with adaptor</li> <li>• NTSC (M, 4.43)</li> <li>• PAL (B, G, H, I, N, M)</li> <li>• SECAM (M)</li> </ul>
<b>Inputs:</b>	(4) HDMI with CEC and Deep Color (1) Component/SCART (3 x RCA) (2) Component/RGBHV (5 x BNC) (3) Composite
<b>Outputs:</b>	(1) HDMI with Deep Color to SC-50d/SC-60d (1) HDMI with Deep Color to second display or audio processor
<b>Control Options:</b>	<ul style="list-style-type: none"> <li>• Front panel vacuum fluorescent display and keypad</li> <li>• Discrete infrared (IR) remote</li> <li>• RS-232 (female DB9) for serial commands</li> <li>• USB (type B female) for firmware upgrade</li> <li>• RS-232 (male DB9) for accessories</li> <li>• 3.5-mm wired IR input for Niles/Xantech-compatible IR systems</li> <li>• Consumer Electronics Control (CEC) protocol support via HDMI</li> <li>• Ethernet</li> </ul>
<b>Ethernet Communication:</b>	RJ45 (female) for web server, e-mail, auto firmware upgrade and Telnet
<b>RS-232 Communication Parameters:</b>	19200 bps, no parity, 8 data bits, 1 stop bit, no flow control
<b>Trigger Outputs:</b>	(3) +12 VDC, each rated at 250 mA and thermal fuse-protected
<b>Accessory Applications:</b>	Runco Firmware Upgrader, Runco BRiC (backup, restore, clone), CalMAN by SpectraCal for automatic calibration
<b>Power Requirements:</b>	100-240V~, 47-63Hz, 0.45 Amps
<b>Operating Environment:</b>	41°F to 104°F (5°C to 40°C), 0% to 90% humidity (non-condensing); up to 10,000 feet (3,048 meters) altitude
<b>Dimensions:</b>	Width = 17.50 inches (444.5 mm) Depth = 11.19 inches (284.1 mm) Height = 3.75 inches (95.3 mm)
<b>Weight:</b>	15.4 lbs. (7.00 kg)

## 7.2 DHD Controller Specifications

**Table 7-2. DHD Controller Specifications (continued)**

**Regulatory Approvals:** cTUVus, FCC class B, CE, RoHS, China RoHS, WEEE, C-Tick, CCC, local conformances as required

**Limited Warranty:** Two (2) years parts and labor from the date of shipment from Runco.

**Specifications are subject to change without notice.**

Figure 7-1 shows the SC-50d/SC-60d dimensions.

### 7.3 SC-50d/SC-60d Dimensions

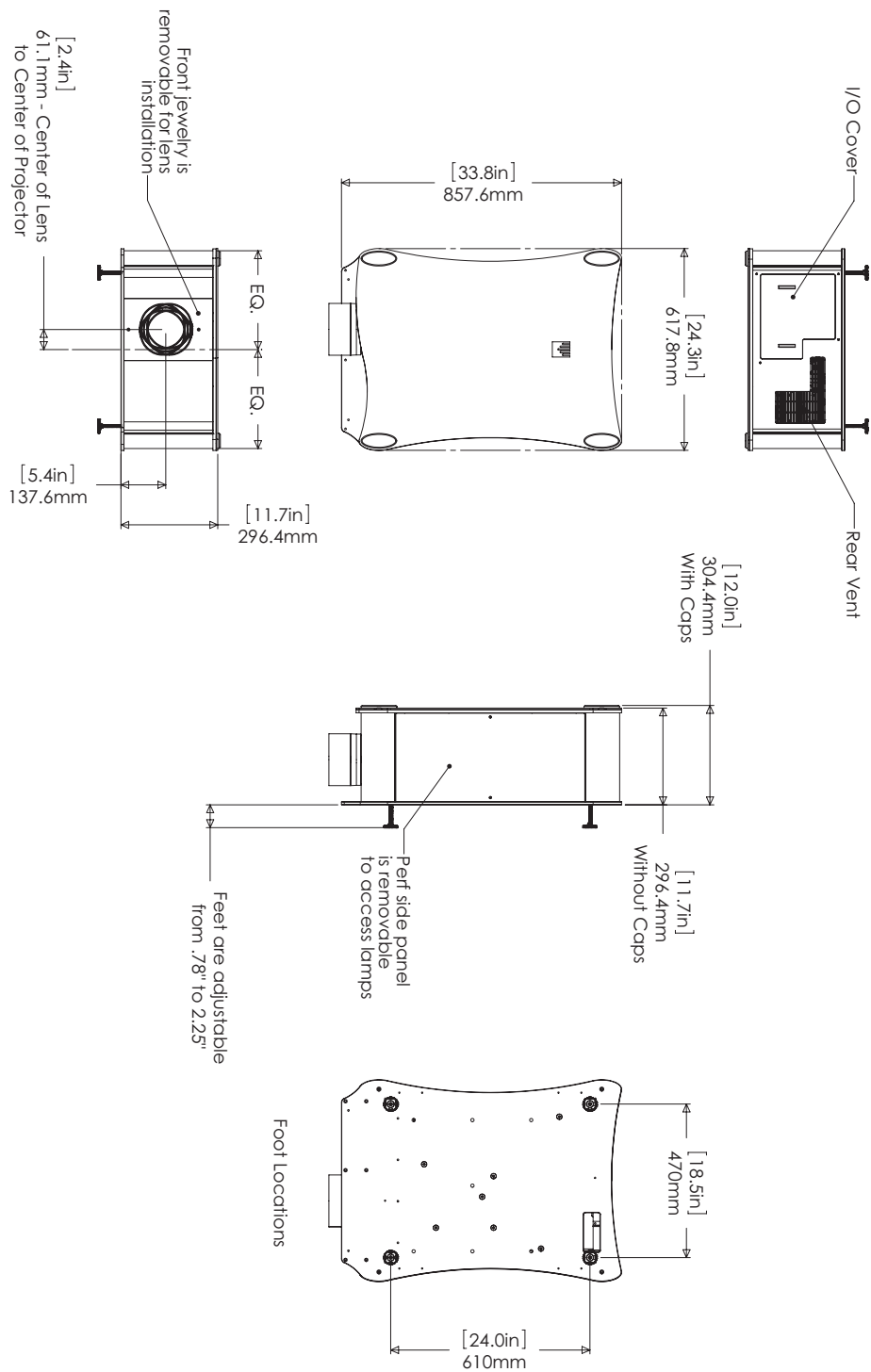
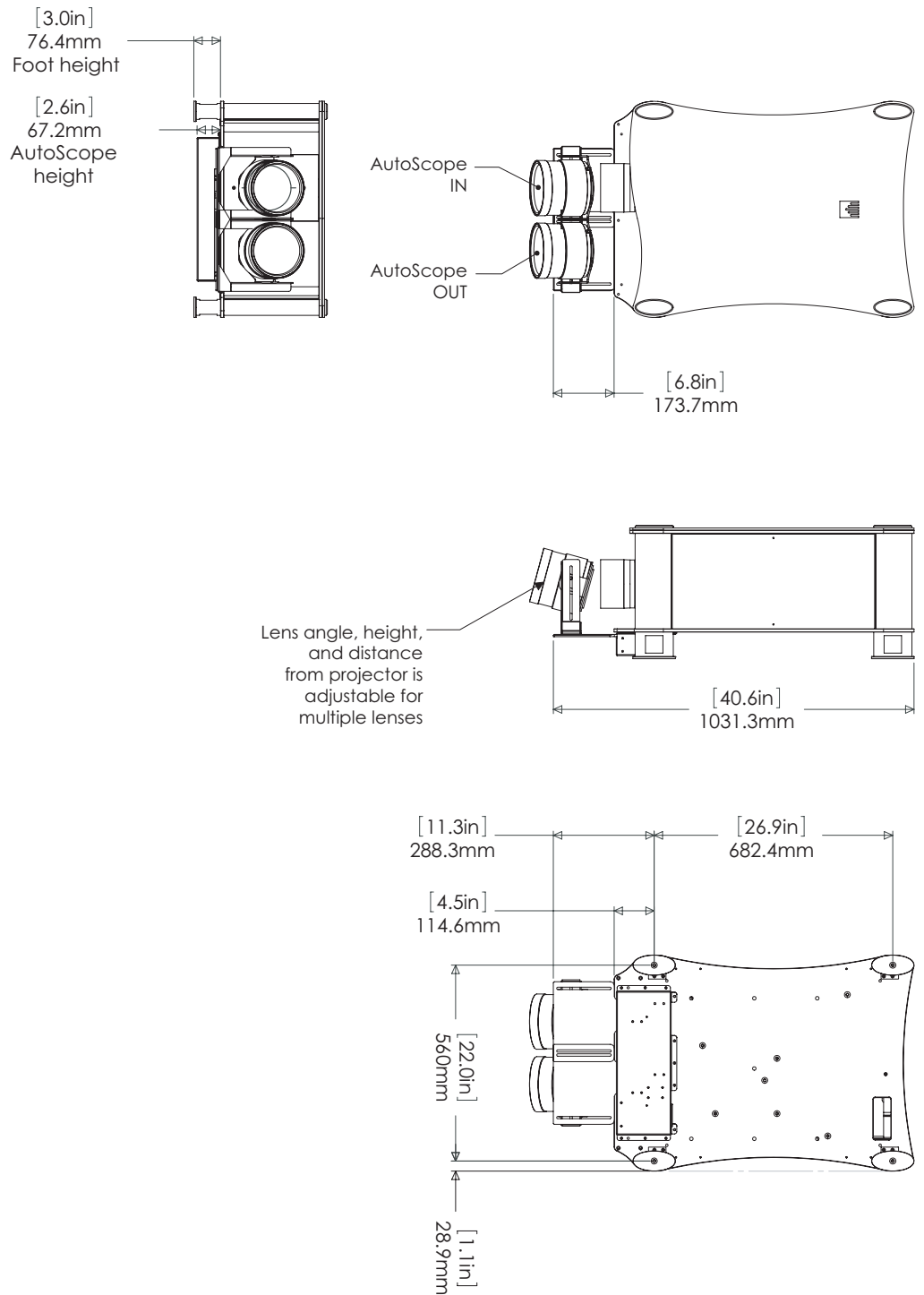

Figure 7-1. SC-50d/SC-60d Dimensions

**7.4**  
**SC-50d/SC-60d**  
**Dimensions with**  
**CineWide with**  
**AutoScope Assembly**

Figure 7-2 shows the SC-50d/SC-60d dimensions with the optional CineWide with AutoScope assembly.



**Figure 7-2. SC-50d/CineWide with AutoScope and SC-60d/CineWide with AutoScope Dimensions**

Table 7-3 lists the signal types supported by each input on the DHD Controller.

## 7.5 Supported Timings

**Table 7-3. Supported Signal Timings by Input**

Format	Resolution	Refresh Rate (Hz)	Horizontal Frequency (kHz)	Pixel Frequency (MHz)	Supported? (√ = Yes, – = No)				
					HD 1 HD 2	HDMI 1 HDMI 2 HDMI 3 HDMI 4	Component	SCART	Composite 1 Composite 2 Composite 3
640x480	640x480	60.00	31.469	25.175	√	√	√	–	–
		66.59	35.892	29.862	√	√	√	–	–
		72.00	37.861	31.500	√	√	√	–	–
		75.00	37.500	31.500	√	√	√	–	–
		85.00	43.269	36.000	√	√	√	–	–
800x600	800x600	60.00	37.879	40.000	√	√	√	–	–
		72.00	48.077	50.000	√	√	√	–	–
		75.00	46.875	49.500	√	√	√	–	–
		85.00	53.674	56.250	√	√	√	–	–
832x624	832x624	74.54	52.849	60.036	√	√	√	–	–
848x480	848x480	47.95	25.270	27.089	√	√	√	–	–
		60.00	31.020	33.750	√	√	√	–	–
1024x768	1024x768	60.00	48.363	65.000	√	√	√	–	–
		70.00	56.476	75.000	√	√	√	–	–
		75.00	60.023	78.750	√	√	√	–	–
		85.00	68.677	94.500	√	√	√	–	–
1152x864	1152x864	75.00	67.500	108.000	√	√	√	–	–
1280x720	1280x720	47.95	37.833	64.769	√	√	√	–	–
1280x768	1280x768	60.00	47.396	68.250	√	√	√	–	–
		60.00	47.776	79.500	√	√	√	–	–
		75.00	60.289	102.250	√	√	√	–	–
		85.00	68.633	117.500	√	√	√	–	–
1280x960	1280x960	60.00	60.000	108.000	√	√	√	–	–
		85.00	85.938	148.500	√	√	√	–	–

**Table 7-3. Supported Signal Timings by Input (continued)**

Format	Resolution	Refresh Rate (Hz)	Horizontal Frequency (kHz)	Pixel Frequency (MHz)	Supported? (√ = Yes, – = No)				
					HD 1 HD 2	HDMI 1 HDMI 2 HDMI 3 HDMI 4	Component	SCART	Composite 1 Composite 2 Composite 3
1280x1024	1280x1024	60.00	63.981	108.000	√	√	√	–	–
		75.00	79.976	135.000	√	√	√	–	–
		85.00	91.146	157.500	√	√	√	–	–
1360x768	1360x768	60.00	47.712	85.500	√	√	√	–	–
1400x1050	1400x1050	60.00	64.744	101.000	√	√	√	–	–
		60.00	65.317	121.750	√	√	√	–	–
		75.00	82.278	156.000	√	√	√	–	–
1600x1200	1600x1200	60.00	75.000	162.000	√	√	√	–	–
1680x1050	1680x1050	60.00	64.674	119.000	√	√	√	–	–
1920x1080	1920x1080	47.95	56.821	150.007	√	√	√	–	–
1920x1200	1920x1200	60.00	74.038	154.000	√	√	√	–	–
SCART RGBS	–	50.00	–	–	–	–	–	√	–
480/60i	720x487	59.94	15.734	13.500	√	√	√	–	–
480/60p	720x483	59.94	31.469	27.000	√	√	√	–	–
576/50i	720x576	50.00	15.625	14.750	√	√	√	–	–
576/50p	720x576	50.00	31.250	29.000	√	√	√	–	–
720/24p	1280x720	23.98/24.00	17.982/18.000	59.341/59.400	√	√	√	–	–
720/25p	1280x720	25.00	18.750	74.250	√	√	√	–	–
720/30p	1280x720	29.97/30.00	22.478/22.500	74.175/74.250	√	√	√	–	–
720/50p	1280x720	50.00	37.500	75.250	√	√	√	–	–
720/60p	1280x720	60.00	45.000	74.250	√	√	√	–	–
1080/50i	1920x1080	50.00	28.125/31.250	74.250/72.000	√	√	√	–	–
1080/60i	1920x1080	59.94/60.00	33.716/33.750	74.175/74.250	√	√	√	–	–
1080/24p	1920x1080	23.98/24.00	26.978/27.000	74.175/74.250	√	√	√	–	–
1080/50p	1920x1080	50.00	56.250	148.500	√	√	√	–	–
1080/60p	1920x1080	59.94/60.00	67.433/67.500	148.350/148.500	√	√	√	–	–
NTSC 3.58	–	59.94/60.00	15.734/15.750	3.580	–	–	–	–	√
NTSC 4.43	–	59.94/60.00	15.734/15.750	4.430	–	–	–	–	√
PAL-B/G/H/I	–	50.00	15.625	4.430	–	–	–	–	√



**Table 7-3. Supported Signal Timings by Input (continued)**

Format	Resolution	Refresh Rate (Hz)	Horizontal Frequency (kHz)	Pixel Frequency (MHz)	Supported? (√ = Yes, – = No)				
					HD 1 HD 2	HDMI 1 HDMI 2 HDMI 3 HDMI 4	Component	SCART	Composite 1 Composite 2 Composite 3
1280x1024	1280x1024	60.00	63.981	108.000	√	√	√	–	–
		75.00	79.976	135.000	√	√	√	–	–
		85.00	91.146	157.500	√	√	√	–	–
1360x768	1360x768	60.00	47.712	85.500	√	√	√	–	–
1400x1050	1400x1050	60.00	64.744	101.000	√	√	√	–	–
		60.00	65.317	121.750	√	√	√	–	–
		75.00	82.278	156.000	√	√	√	–	–
1600x1200	1600x1200	60.00	75.000	162.000	√	√	√	–	–
1680x1050	1680x1050	60.00	64.674	119.000	√	√	√	–	–
1920x1080	1920x1080	47.95	56.821	150.007	√	√	√	–	–
1920x1200	1920x1200	60.00	74.038	154.000	√	√	√	–	–
SCART RGBS	–	50.00	–	–	–	–	–	√	–
480/60i	720x487	59.94	15.734	13.500	√	√	√	–	–
480/60p	720x483	59.94	31.469	27.000	√	√	√	–	–
576/50i	720x576	50.00	15.625	14.750	√	√	√	–	–
576/50p	720x576	50.00	31.250	29.000	√	√	√	–	–
720/24p	1280x720	23.98/24.00	17.982/18.000	59.341/59.400	√	√	√	–	–
720/25p	1280x720	25.00	18.750	74.250	√	√	√	–	–
720/30p	1280x720	29.97/30.00	22.478/22.500	74.175/74.250	√	√	√	–	–
720/50p	1280x720	50.00	37.500	75.250	√	√	√	–	–
720/60p	1280x720	60.00	45.000	74.250	√	√	√	–	–
1080/50i	1920x1080	50.00	28.125/31.250	74.250/72.000	√	√	√	–	–
1080/60i	1920x1080	59.94/60.00	33.716/33.750	74.175/74.250	√	√	√	–	–
1080/24p	1920x1080	23.98/24.00	26.978/27.000	74.175/74.250	√	√	√	–	–
1080/50p	1920x1080	50.00	56.250	148.500	√	√	√	–	–
1080/60p	1920x1080	59.94/60.00	67.433/67.500	148.350/148.500	√	√	√	–	–
NTSC 3.58	–	59.94/60.00	15.734/15.750	3.580	–	–	–	–	√
NTSC 4.43	–	59.94/60.00	15.734/15.750	4.430	–	–	–	–	√
PAL-B/G/H/I	–	50.00	15.625	4.430	–	–	–	–	√

**Table 7-3. Supported Signal Timings by Input (continued)**

Format	Resolution	Refresh Rate (Hz)	Horizontal Frequency (kHz)	Pixel Frequency (MHz)	Supported? (√ = Yes, – = No)				
					HD 1 HD 2	HDMI 1 HDMI 2 HDMI 3 HDMI 4	Component	SCART	Composite 1 Composite 2 Composite 3
PAL-M	–	59.94/60.00	15.734/15.750	3.580	–	–	–	–	√
PAL-N	–	50.00	15.625	3.580	–	–	–	–	√
SECAM	–	50.00	15.625	13.500	–	–	–	√	√



020-1105-00 Rev. A  
March 2011

---

Runco International • (800) 23RUNCO • Fax (503) 748-8161 • [www.runco.com](http://www.runco.com)

## Free Manuals Download Website

<http://myh66.com>

<http://usermanuals.us>

<http://www.somanuals.com>

<http://www.4manuals.cc>

<http://www.manual-lib.com>

<http://www.404manual.com>

<http://www.luxmanual.com>

<http://aubethermostatmanual.com>

Golf course search by state

<http://golfingnear.com>

Email search by domain

<http://emailbydomain.com>

Auto manuals search

<http://auto.somanuals.com>

TV manuals search

<http://tv.somanuals.com>