

S62 MIXER AMPLIFIER

SAMSON AUDIO

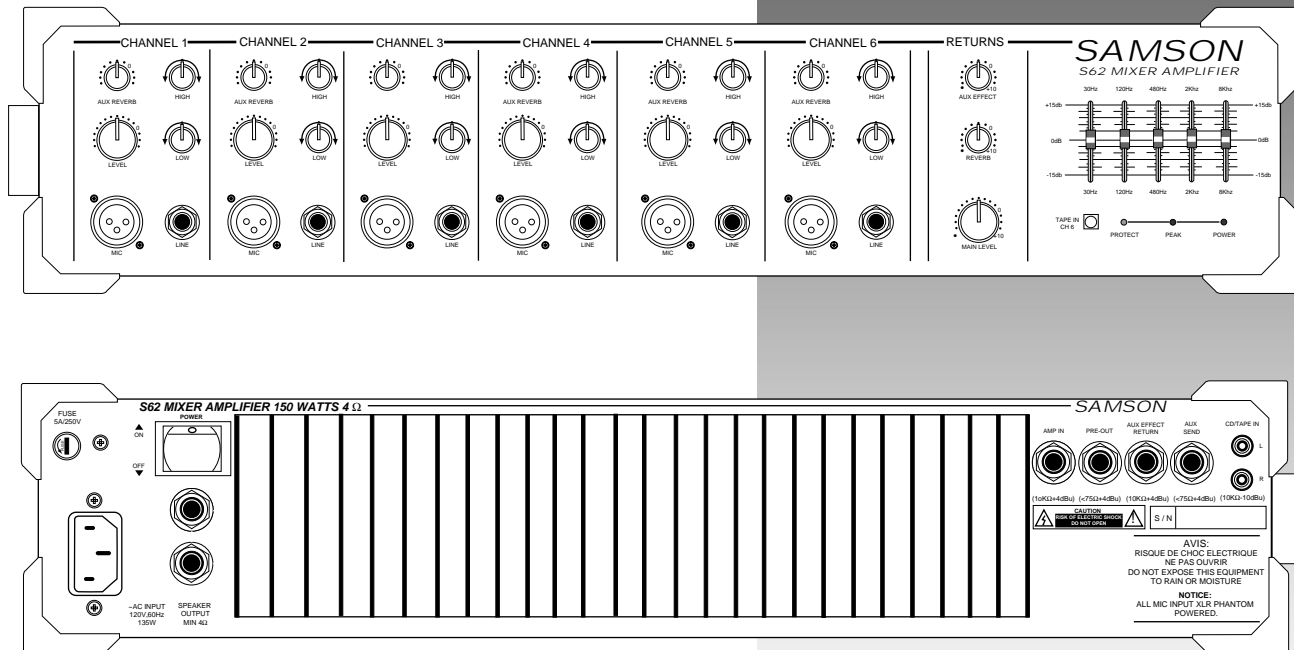

The S62 Mixer Amplifier is a monophonic 6-input mic/line mixer with a dedicated power amp producing 150 W into 4 ohms. Highly portable or easily installed into a rack, the S62 is equipped with 2-band equalization on each channel and a 5-band graphic EQ on the main output. The S62 is an ideal all-in-one device for recording, live concert and contracting applications. It also features 6 electronically balanced mic/line inputs (XLR-type and 1/4" connectors), a CD/tape input (phono connectors), switchable 48 V phantom power, internal reverb, an Aux send and return, along with amp in and preamp and monitor out patch points.

- 6 balanced mic/line-input channels.
- Independent CD/tape input; signal is routed via channel EQ.
- Power: 150 W into 4 ohms.
- Built-in 3-spring reverb.
- 2-band equalization on all channels.
- 5-band graphic master EQ.
- Master peak LED.
- 1 Aux send per channel.
- 1 Aux return with front-panel level control.
- 48 V phantom power selectable for mic input connectors.
- Protection relay circuitry to prevent noise when powering on.
- 2 speaker outputs.
- Extremely portable format with carry handle and protective corners.
- Rackmountable with rack ears included.
- Rear-panel amp in and preamp output.
- Master reverb level control.

Contact:

ARCHITECT'S & ENGINEER'S SPECIFICATION

S62 SPECIFICATIONS

The mixer amplifier shall incorporate a 150 W monophonic amplifier, a 5-band graphic equalizer and a monophonic mixer with 6 microphone/line-input channels. Microphone inputs shall be on XLR-type connectors and line inputs shall be on balanced 1/4" Tip-Ring-Sleeve phone connectors. An independent line-level CD/tape input (routed to channel 6) shall be on phono connectors. Each channel shall have an aux/reverb send, 2-band equalization and a level control.

The mixer shall provide an effects output on a 1/4" phone connector, as well as a preamp out and power amp in for submix applications on 1/4" phone connectors. An effects return shall be provided on a 1/4" phone connector, and it shall have an independent level control. Phantom Power of +48 V shall be provided for operation of condenser microphones. The amplifier shall be passively cooled. Amplifier output shall be provided on two 1/4" phone connectors. Indicators shall be provided for peak level (3 dB before clipping), power and amplifier protection. The unit shall be of a rack-mount type.

The amplifier shall deliver maximum power equal to or greater than 150 W into 4 ohms, signal-to-noise equal to or greater than 95 dB, THD less than 0.1% and frequency response of ± 3 dB from 20 Hz to 50 kHz. The mixer shall have residual noise of 70 dBu, signal-to-noise equal to or greater than 70 dB and THD less than 0.03%. Total power consumed at 1/8 audio power shall be 134 W (115 Vac). Dimensions shall be 19" (480 mm) wide, 9" (230 mm) deep and 3.5" (88 mm; 2 rack spaces) high. Weight shall be 17.6 lb. (8 kg). The mixer amplifier shall carry a three-year warranty.

The mixer amplifier shall be a SAMSON S62.

MIXER/PREAMP SECTION

Total harmonic distortion (with 30 kHz LPF):

Mic in to preamp out:	< 0.05%
Line in to preamp out:	< 0.03%
Aux return to preamp out:	< 0.03%

Signal to noise ratio (with 30 kHz LPF, unity gain):

Mic input (-50 dBu):	67 dB
Line input (-10 dBu):	70 dB

Maximum voltage gain (1 kHz):

Mic in to preamp out:	54 dB
Line in to preamp out:	24 dB
Tape in to preamp out:	24 dB
Aux return to preamp out:	10 dB

Residual noise (with 30 kHz LPF, VR min):

Preamp out:	70 dBu
-------------	--------

Tone controls:

High (10 kHz):	± 15 dB
Low (100 Hz):	± 15 dB
Graphic equalizer (30, 120, 480 Hz, 2, 8 kHz):	± 15 dB

Peak LED:

3 dB before clipping	
300 mV	

Tape input sensitivity (-10 dB):

Crosstalk (1 kHz, EQ flat):

Ch vs. Ch:	76 dB
Input vs. output:	78 dB

POWER AMP SECTION

Rated output power (1 kHz):

150 W into 4 Ω

Total harmonic distortion (with 30 kHz LPF):

< 0.1%

Signal to noise ratio (with 30 kHz LPF):

95 dB

Frequency response (± 3 dB):

20 Hz - 50 kHz

Maximum voltage gain (1 kHz):

36 dB

Residual noise (VR min):

70 dB typical

Idle current (across the 0.47 Ω emitter resistor):

< 20 mA

DC offset voltage:

0 \pm 50 mV

GENERAL

Dimensions:

19" (w) x 9" (d) x 3.5" (h)
480 mm (w) x 230 mm (d) x 88 mm (h)

Weight:

17.6 lb. / 8 kg.

Power requirements:

115 Vac • 50/60 Hz

Power consumption (1/8 power):

134 W (115 Vac)

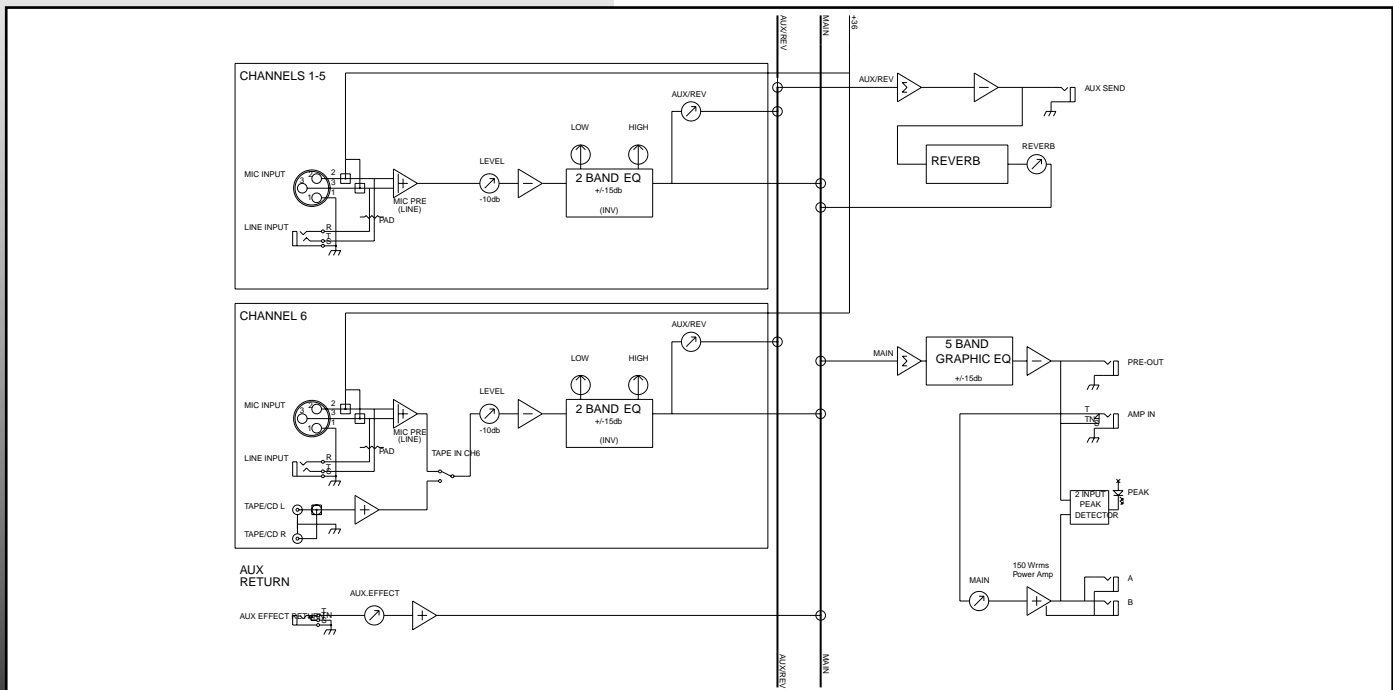

Free Manuals Download Website

<http://myh66.com>

<http://usermanuals.us>

<http://www.somanuals.com>

<http://www.4manuals.cc>

<http://www.manual-lib.com>

<http://www.404manual.com>

<http://www.luxmanual.com>

<http://aubethermostatmanual.com>

Golf course search by state

<http://golfingnear.com>

Email search by domain

<http://emailbydomain.com>

Auto manuals search

<http://auto.somanuals.com>

TV manuals search

<http://tv.somanuals.com>