

**V3622 / C3622**

---

**SPLIT SYSTEM AIR CONDITIONER**

Indoor Unit

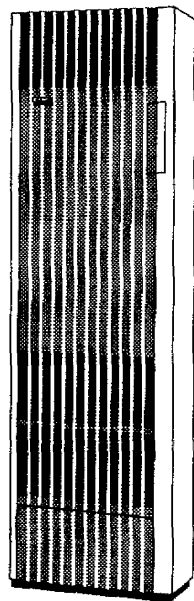

**V3622**

Outdoor Unit

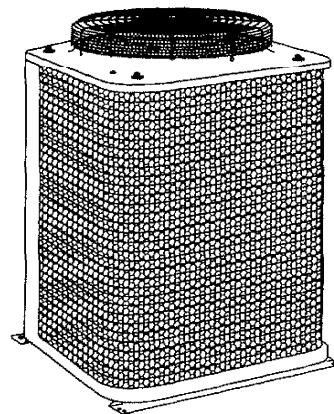

**C3622**

# **SERVICE MANUAL**

**V3622 / C3622**

**(Expanded Information)**

## IMPORTANT! Please Read Before Starting

This air conditioning system meets strict safety and operating standards. As the installer or service person, it is an important part of your job to install or service the system so it operates safely and efficiently.

For safe installation and trouble-free operation, you must:

- Carefully read this instruction booklet before beginning
- Follow each installation or repair step exactly as shown
- Observe all local, state, and national electrical codes
- Pay close attention to all warning and caution notices given in this manual



**WARNING:**

This symbol refers to a hazard or unsafe practice which can result in severe personal injury or death.



**CAUTION:**

This symbol refers to a hazard or unsafe practice which can result in personal injury or product or property damage.

### If Necessary, Get Help

These instructions are all you need for most installation sites and maintenance conditions. If you require help for a special problem, contact our sales/service outlet or your certified dealer for additional instructions.

### In Case of Improper Installation

The manufacturer shall in no way be responsible for improper installation or maintenance service, including failure to follow the instructions in this document.

## SPECIAL PRECAUTIONS

### When Wiring

**ELECTRICAL SHOCK CAN CAUSE SEVERE PERSONAL INJURY OR DEATH. ONLY A QUALIFIED, EXPERIENCED ELECTRICIAN SHOULD ATTEMPT TO WIRE THIS SYSTEM.**

- Do not supply power to the unit until all wiring and tubing are completed or reconnected and checked.
- Highly dangerous electrical voltages are used in this system. Carefully refer to the wiring diagram and these instructions when wiring. Improper connections and inadequate grounding can cause **accidental injury or death**.
- **Ground the unit** following local electrical codes.
- Connect all wiring tightly. Loose wiring may cause overheating at connection points and a possible fire hazard.

### When Transporting

Be careful when picking up and moving the indoor and outdoor units. Get a partner to help, and bend your knees when lifting to reduce strain on your back. Sharp edges or thin aluminum fins on the air conditioner can cut your fingers.

### When Installing...

#### ...In a Ceiling or Wall

Make sure the ceiling/wall is strong enough to hold the unit's weight. It may be necessary to construct a strong wood or metal frame to provide added support.

#### ...In a Room

Properly insulate any tubing run inside a room to prevent "sweating" that can cause dripping and water damage to walls and floors.

#### ...In Moist or Uneven Locations

Use a raised concrete pad or concrete blocks to provide a solid, level foundation for the outdoor unit. This prevents water damage and abnormal vibration.

#### ...In an Area with High Winds

Securely anchor the outdoor unit down with bolts and a metal frame. Provide a suitable air baffle.

#### ...In a Snowy Area (for Heat Pump-type Systems)

Install the outdoor unit on a raised platform that is higher than drifting snow. Provide snow vents.

### When Connecting Refrigerant Tubing

- Keep all tubing runs as short as possible.
- Use the flare method for connecting tubing.
- Apply refrigerant lubricant to the matching surfaces of the flare and union tubes before connecting them, then **tighten** the nut with a torque wrench for a leak-free connection.
- Check carefully for leaks before starting the test run.

#### NOTE:

Depending on the system type, liquid and gas lines may be either narrow or wide. Therefore, to avoid confusion the refrigerant tubing for your particular model is specified as either "narrow" or "wide" rather than as "liquid" or "gas."

### When Servicing

- Turn the power OFF at the main power box (mains) before opening the unit to check or repair electrical parts and wiring.
- Keep your fingers and clothing away from any moving parts.
- Clean up the site after you finish, remembering to check that no metal scraps or bits of wiring have been left inside the unit being serviced.

# Table of Contents

	Page
<b>1. SPECIFICATIONS</b>	
1-1 Unit Specifications .....	1
1-2 Major Component Specifications .....	2
(1) Indoor Unit .....	2
(2) Outdoor Unit .....	3
1-3 Other Component Specifications .....	4
(1) Indoor Unit .....	4
(2) Outdoor Unit .....	4
<b>2. PERFORMANCE CHARTS</b>	
2-1 Operating Current .....	5
2-2 High and Low Pressure .....	6
<b>3. FUNCTION</b>	
3-1 Room Temperature Control .....	8
3-2 Freeze Prevention .....	9
3-3 Outdoor Fan Speed Control .....	9
<b>4. ELECTRICAL DATA</b>	
● Schematic Diagram .....	10
● Electric Wiring Diagram (PCB Ass'y) .....	11
<b>5. TROUBLESHOOTING</b>	
5-1 Check before and after troubleshooting .....	13
(1) Check power supply wiring .....	13
(2) Check inter-unit wiring .....	13
(3) Check power supply .....	13
(4) Check lead wires and connectors in indoor and outdoor units .....	13
5-2 Air conditioner does not operate .....	14
(1) Circuit breaker trips (or fuse blows) .....	14
(a) When circuit breaker is set to ON, it trips in a few moments	
(b) Circuit breaker trips in several minutes after turning air conditioner ON	
(2) Neither indoor unit nor outdoor unit runs .....	16
(a) Power is not supplied	
(b) Check fuse on PCB Ass'y in indoor unit	
(c) Check control unit (RCS-36V)	
(d) Check transformer	
(e) Check high pressure switch (63PH)	

(3) Only outdoor unit does not run.....	18
(a) Outdoor unit does not run when air conditioner is in the following conditions	
(b) Check electro-magnetic contactor (52C)	
(c) Check PCB Ass'y (POW-36V)	
5-3 A particular component of air conditioner does not operate .....	19
(1) Only indoor fan does not run.....	19
(2) Only outdoor fan does not run.....	20
(3) Only compressor does not run.....	21
5-4 Air conditioner operates, but abnormalities occur.....	22
(1) Poor Cooling.....	22
(2) Excessive Cooling .....	23

## 6. CHECKING ELECTRICAL COMPONENTS

6-1 Measurement of Insulation Resistance .....	24
(1) Power Supply Wires .....	24
(2) Indoor Unit .....	24
(3) Outdoor Unit.....	24
(4) Measurement of Insulation Resistance for Electrical Parts .....	24
6-2 Checking Continuity of Fuse on PCB Ass'y .....	25
6-3 Checking Motor Capacitor .....	25
6-4 Checking Control Unit (RCS-36V) Proper .....	26
(1) Checking Operation Switch — SW1 .....	26
(2) Checking Fan Speed Selector — SW2.....	26
(3) Checking Auto Deflector Switch — SW3.....	26
6-5 Appearance of Electrical Parts .....	27
(1) Freeze Protection Thermostat.....	27
(2) High Pressure Switch.....	27
(3) Thermistor (PTC) .....	27
(4) Electro-Magnetic Contactor.....	28
(5) Thermostat .....	28

# I. SPECIFICATIONS

## 1-1 Unit Specifications

Model No.		Indoor unit	V3622	
		Outdoor unit	C3622	
Performance			Cooling	
	Capacity	BTU/h	34,000 / 33,000	
		kW	9.96 / 9.67	
	Air circulation (High)	cu. ft./min.	700 / 620	
Moisture removal (High)	pints/h	10.0 / 9.6		
Electrical Rating	Phase, Frequency	Hz	Single, 60	
	Voltage rating	V	230 / 208	
	Available voltage range	V	187 to 253	
	Running amperes	A	16.0 / 16.7	
	Power input	W	3,450 / 3,350	
	Power factor	%	94 / 96	
	Starting amperes	A	98	
	S. E. E. R.	BTU/Wh	10.2 / 10.3	
Features	Controls		IC	
	Control unit		Built-in	
	Temperature control		IC thermostat	
	Fan speeds	Indoor / Outdoor	2 / 1	
	Air deflector	Horizontal / Vertical	Automatic / Manual	
	Air filter		Washable, easy access	
	Compressor		Rotary	
	Refrigerant amount charged at shipment	lbs. (kg)	R22: 9.9 (4.5)	
	Refrigerant control		Capillary tube	
	Refrigerant tubing connections		Flare type	
	Operation sound	In-Hi / Me / Lo	dB-A	51 / — / 46
		Out-Hi	dB-A	62
	Max. allowable tubing length at shipment	ft. (m)	50 (15)	
	Limit of elevation difference between the 2 units	ft. (m)	Outdoor unit is higher than indoor unit: 50 (15) Outdoor unit is lower than indoor unit: 50 (15)	
	Refrigerant tube o.d.	Narrow tube	in. (mm)	3/8 (9.52)
		Wide tube	in. (mm)	3/4 (19.05)
Refrigerant tube kir		Optional		
Accessories		—		
Dimensions & Weight			Indoor unit	
			Outdoor unit	
	Height	in. (mm)	74-13/16 (1,900)	
	Width	in. (mm)	21-1/4 (540)	
	Depth	in. (mm)	9-3/4 (248)	
	Net weight	lbs. (kg)	110 (50)	
Shipping volume	cu. ft. (cu. m)	16.5 (0.463)		
Shipping weight	lbs. (kg)	135 (60.8)		

DATA SUBJECT TO CHANGE WITHOUT NOTICE.

**Remarks:** Rating conditions are: Outside air temperature 95°F DB/75°F WB  
Indoor unit entering air temperature 80°F DB/67°F WB

## 1-2 Major Component Specifications

### (1) Indoor Unit

Unit Model No.		V3622		
Control Unit		RCS-36V		
Controller PCB	Controls	POW-36V		
	Control circuit fuse	I.C.		
Fan	Type	Centrifugal		
	Number ... Dia. and length	in. (mm)	1 ... O.D. 15 (380), L 7 (180)	
Fan Motor	Model ... Number	KFC8S-81A6P ... 1		
	No. of pole ... rpm (230V, High)	8 ... 460		
	Nominal output	W	80	
	Coil resistance (Ambient temp. 68°F)	Ω	WHT - BRN: 204.5 WHT - PNK: 25.8 WHT - YEL: 34.3	
	Safety devices	Type	Internal	
		Operating temp.	Open	°F 248 ± 9
			Close	°F 171 ± 27
	Run capacitor		μF 6	
		VAC 440		
Auto Deflector Motor	Model	M12		
	Rating	220 to 240V, 60Hz		
	No. of pole ... rpm	12 ... 5		
	Output	W	3	
	Coil resistance (at 77°F)	kΩ	11.5 ± 5%	
Heat Exch.	Coil	Aluminum plate fin / Copper tube		
	Rows ... Fins per inch	3 ... 14.1		
	Face area	ft. <sup>2</sup> (m <sup>2</sup> )	4.75 (0.44)	

DATA SUBJECT TO CHANGE WITHOUT NOTICE.

(2) Outdoor Unit

Unit Model No.		C3622		
Compressor	Model ... Number		Rotary (hermetic) C-R221H8U ... 1	
	No. of cyl. ... rpm		1 ... 3,500	
	Nominal output W (H.P.)		2,200 (3)	
	Compressor lubricant cc		1,500	
	Coil resistance (Ambient temp. 77°F) Ω		C - R: 0.760 C - S: 2.762	
	Safety devices	Type		Internal
		Overload relay models		—
		Operating temp.	Open °F	160 ± 5
			Close °F	87 ± 11
	Operating amp. (Ambient temp. 77°F)		—	
Run capacitor μF		40		
VAC		370		
Fan	Crank case heater		—	
	Type		Propeller	
Number ... Dia. in. (mm)		1 ... 19-15/16 (500)		
Fan Motor	Model		KFC6S-161A6P	
	No. of pole ... rpm (230V, High)		6 ... 820	
	Nominal output W (H.P.)		160 (1/5)	
	Coil resistance (Ambient temp. 68°F) Ω		WHT - BRN: 34.9 WHT - PNK: 72.1 PNK - YEL: 81.6	
	Safety devices	Type		Internal
		Operating temp.	Open °F	248 ± 9
			Close °F	171 ± 27
Run capacitor μF		4		
VAC		440		
Heat Exch.	Coil		Aluminum plate fin / Copper tube	
	Rows ... Fins per inch		2 ... 12.7	
	Face area ft. <sup>2</sup> (m <sup>2</sup> )		13.17 (1.22)	
External Finish		Acrylic baked-on enamel finish		

DATA SUBJECT TO CHANGE WITHOUT NOTICE.



### 1-3 Other Component Specifications

#### (1) Indoor Unit

<b>Transformer</b>			<b>ATR-J122U</b>
Rated	Primary		AC 220V, 60Hz
	Secondary		19V, 0.63A
	Capacity		12VA
Coil resistance	$\Omega$ (at 79°F)		Primary (WHT – WHT): 146.9 Secondary (BRN – BRN): 1.3
Thermo fuse			259°F, 2A 250V

<b>Freeze Protection Thermostat</b>			<b>RTB-4U303</b>
Operating temp.	°F	ON	50 ± 3.5
		OFF	23 ± 3
Contact rating			200 to 240V, 1A

<b>Thermistor (room sensor)</b>			<b>OCS5K-UL</b>
Resistance	k $\Omega$		32°F 16.54 ± 4%      77°F 5.0 ± 4% 50°F 10.03 ± 4%      86°F 4.02 ± 4% 68°F 6.27 ± 4%

#### (2) Outdoor Unit

<b>High Pressure Switch</b>			<b>FTB-2UC01</b>
Operating pressure	psig	OFF	412 + 14, -7
		ON	Manual
Contact rating			AC 240V, 4A

<b>Thermistor (PTC)</b>			<b>TDK 101YV</b>
Resistance	$\Omega$ (at 77°F)		100 ± 20%

<b>Electro-Magnetic Contactor</b>			<b>FMCA-1SUL</b>
Coil rating			AC 240V
Coil resistance	$\Omega$ (at 77°F)		580 ± 15%
Contact rating (Main)			AC 240V, 26A
(Auxiliary)			AC 240V, 3A

<b>Thermostat</b>			<b>YTB-4U305F</b>
Operating temp.	°F	ON	75 + 3, -1
		OFF	79 ± 3
Contact rating			200 to 240V, 1A

## 2. PERFORMANCE CHARTS

### 2-1 Operating Current

Operating current characteristics versus outdoor ambient temperature and indoor temperature  
(Indoor relative humidity: 50%, Indoor fan speed: High)

#### 230V

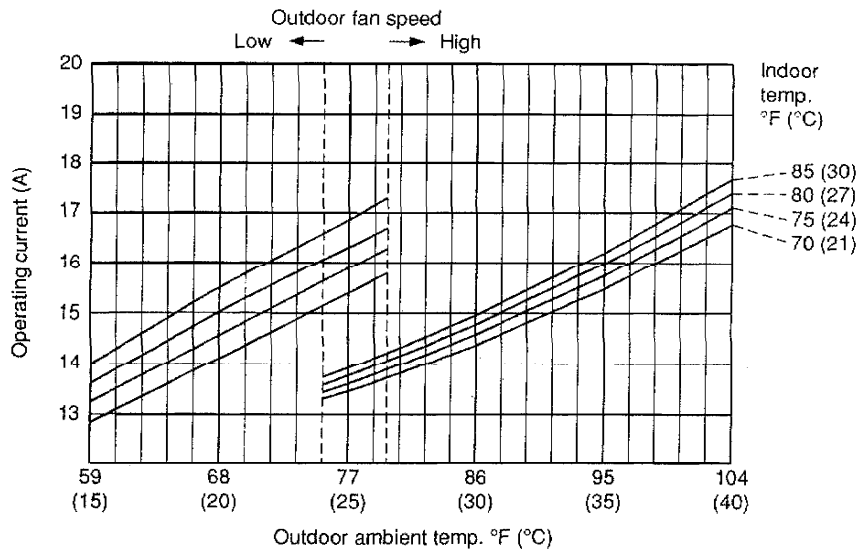

#### 208V

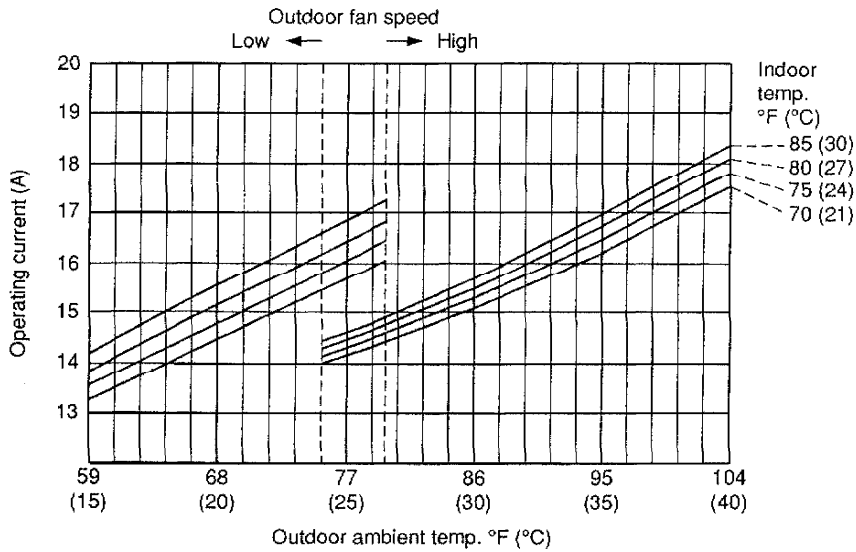

## 2-2 High and Low Pressure

### ● High Pressure

High pressure characteristics versus outdoor ambient temperature and indoor temperature  
(Indoor relative humidity: 50%, Indoor fan speed: High)

230V

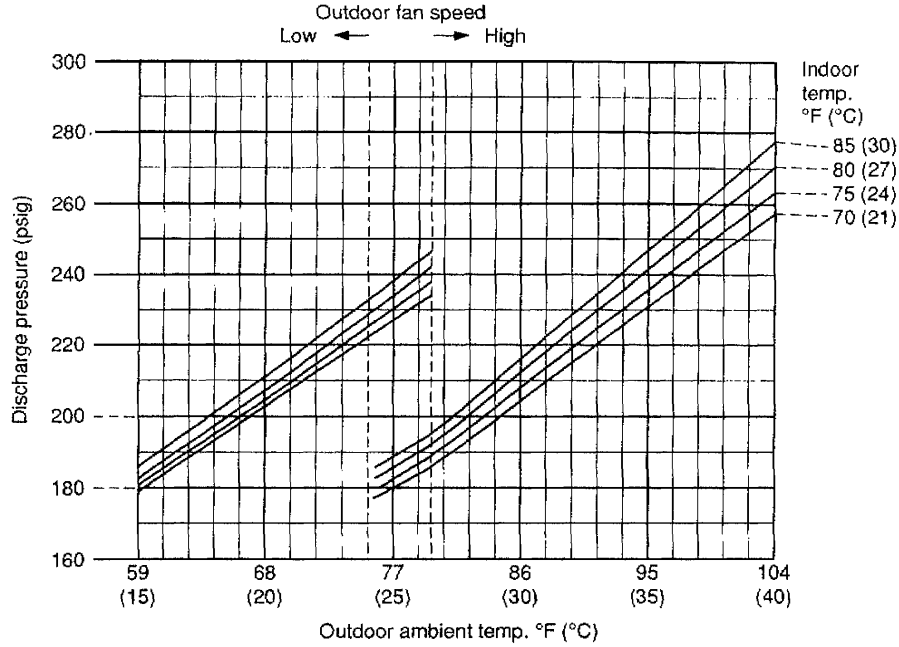

### ● Low Pressure

Low pressure characteristics versus outdoor ambient temperature and indoor temperature  
(Indoor relative humidity: 50%, Indoor fan speed: High)

230V

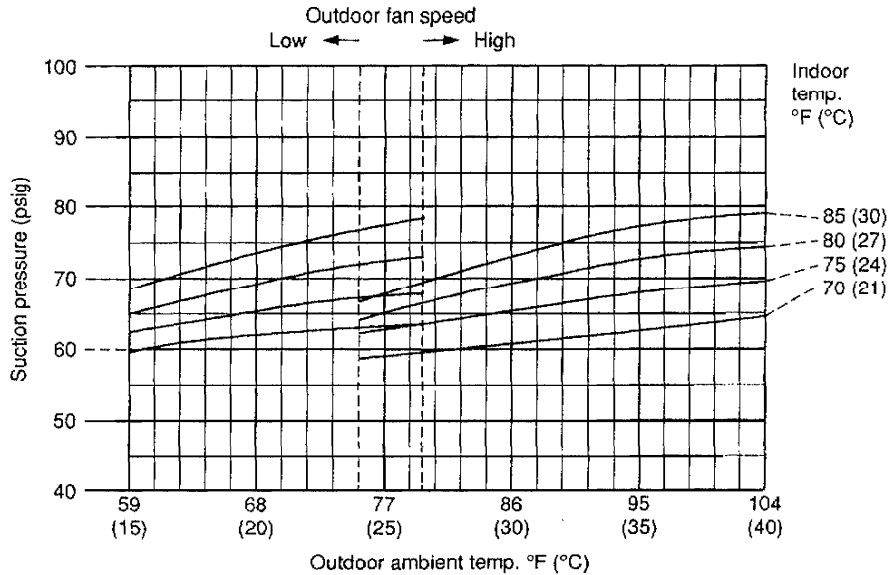

● **High Pressure**

High pressure characteristics versus outdoor ambient temperature and indoor temperature  
 (Indoor relative humidity: 50%, Indoor fan speed: High)

208V

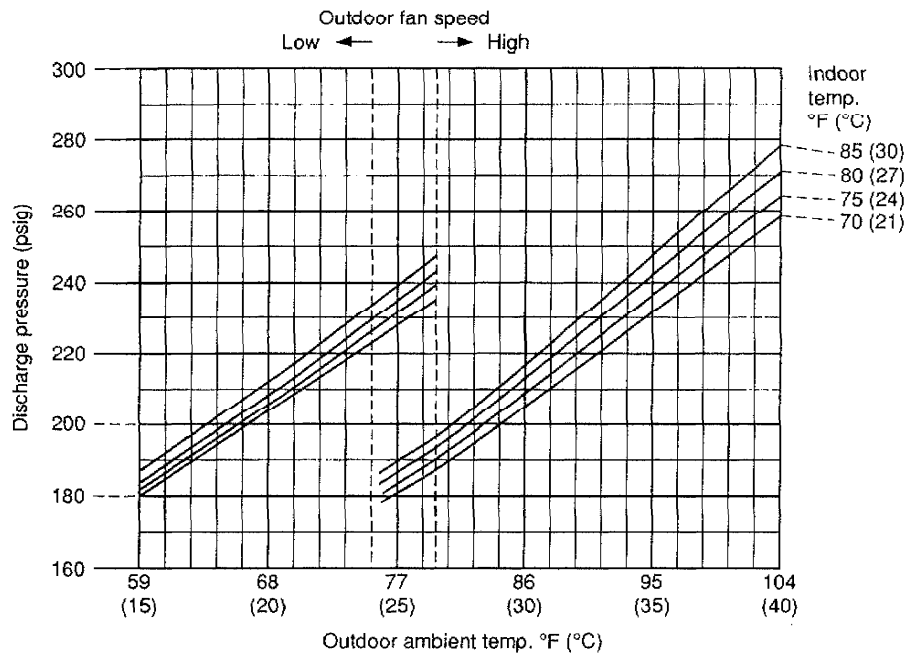

● **Low Pressure**

Low pressure characteristics versus outdoor ambient temperature and indoor temperature  
 (Indoor relative humidity: 50%, Indoor fan speed: High)

208V

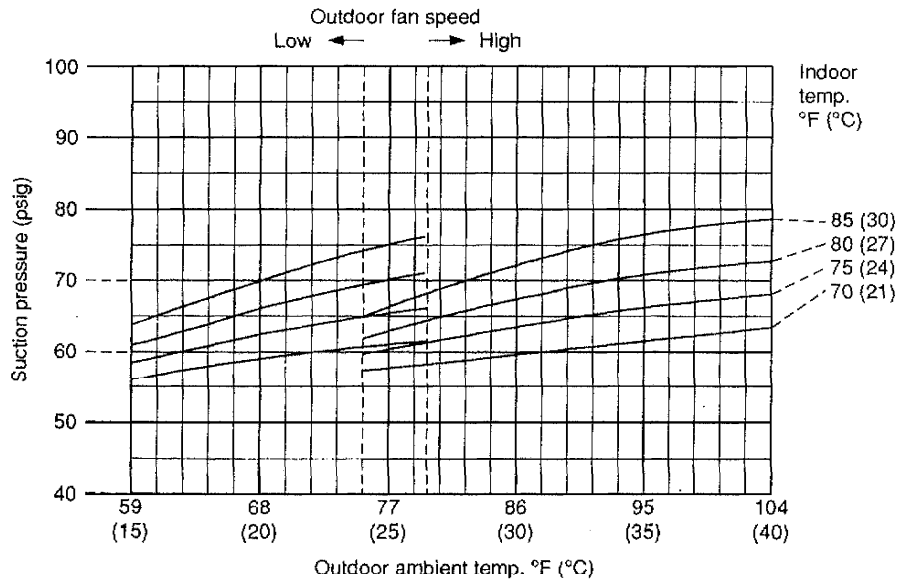

### 3. FUNCTION

#### 3-1 Room Temperature Control

- Room temperature control is obtained by cycling the compressor ON and OFF under control of the room temperature sensor in the remote control unit.
- The compressor turns OFF below the setting temperature, and turns ON above the differential temperature (about 2°F).

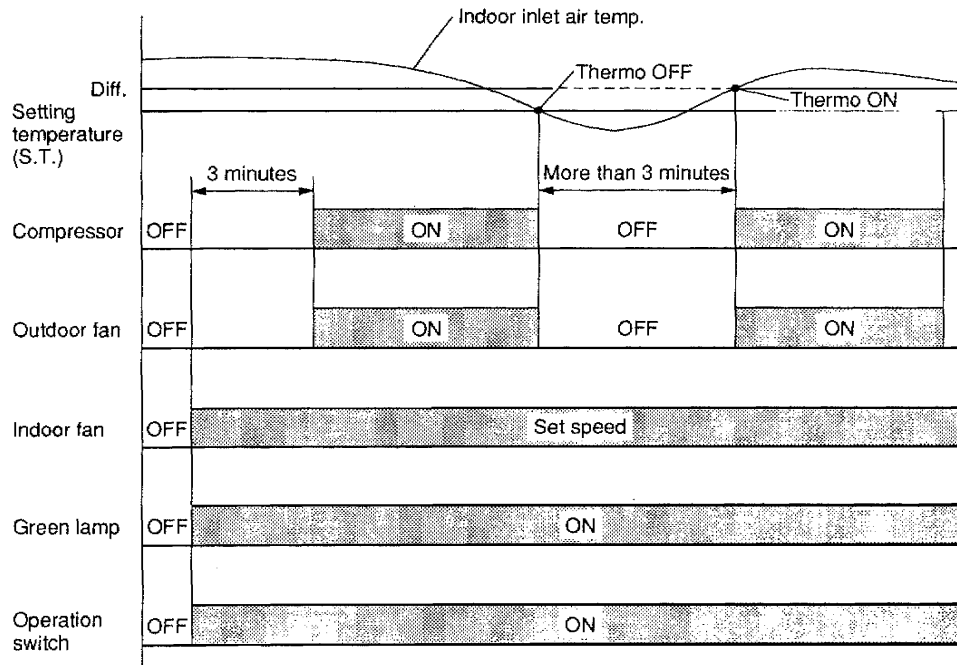

- The control circuit will not attempt to turn the compressor ON until the compressor has been OFF for at least 3 minutes. To protect the compressor from stalling out when trying to start against the high side refrigerant pressure, the control circuit has a built-in automatic time delay to allow the internal pressure to equalize.

### 3-2 Freeze Prevention

- When the coil temperature falls below 23°F, the compressor turns OFF.  
When the coil temperature rises above 50°F, the compressor turns ON again.

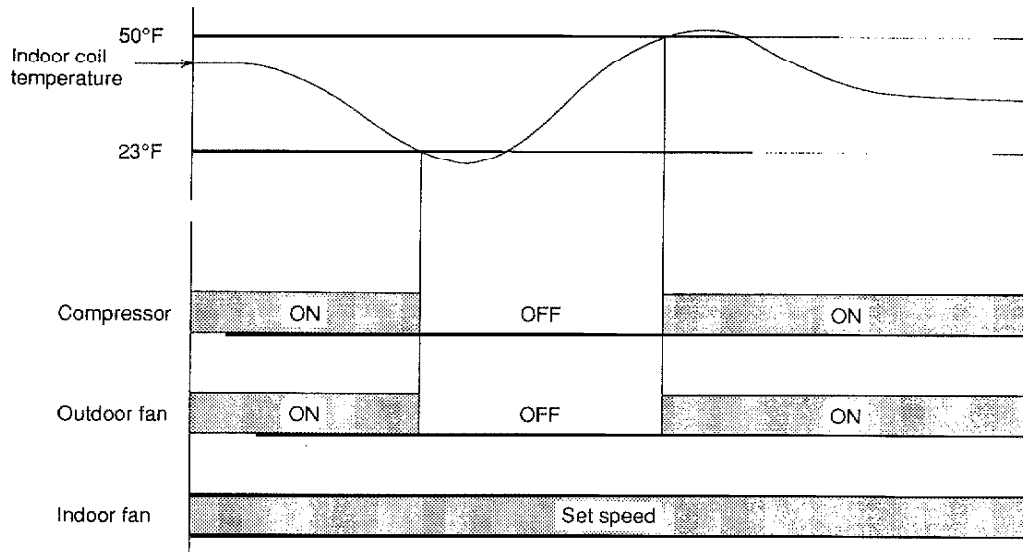

### 3-3 Outdoor Fan Speed Control

- In low temperature areas, the outdoor fan is set automatically to LOW to prevent freezing.
- When the outdoor air temperature falls below 75°F, the outdoor fan is set to LOW.  
When the outdoor air temperature rises to 79°F, the outdoor fan is set to HIGH.

# 4. ELECTRICAL DATA

## ● Schematic Diagram

V3622 / C3622

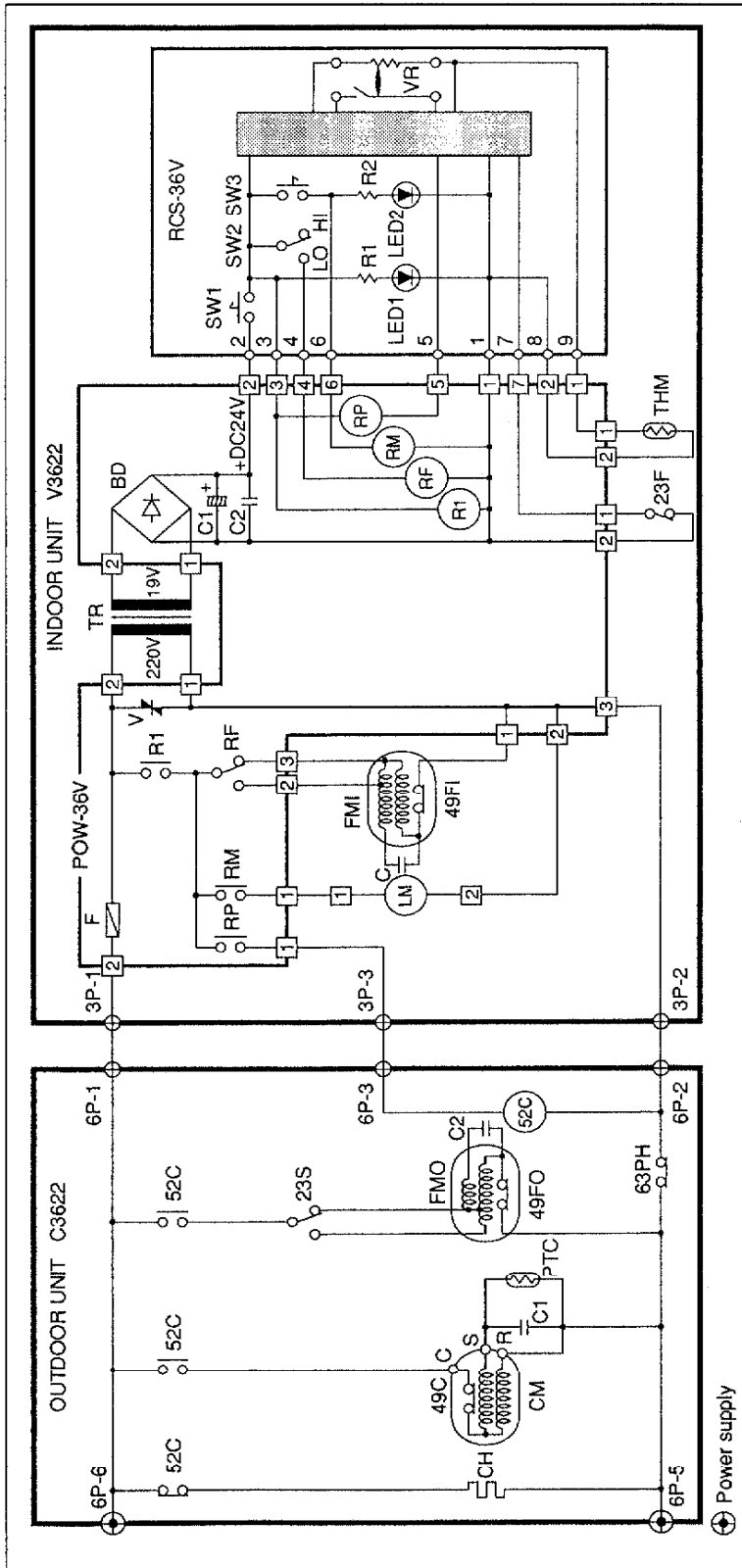

Symbol	Description	Symbol	Description
OUTDOOR UNIT		TR	TRANSFORMER
CH	CRANK CASE HEATER	THM	THERMISTOR
CM	COMPRESSOR MOTOR	23F	FREEZE PROTECTION THERMOSTAT
49C	COMPRESSOR MOTOR INTERNAL PROTECTOR	POW-36V	CONTROLLER PCB ASSY
PTC	THERMISTOR	F	ELSE 250V, 5A
23S	THERMOSTAT	V	VARIABLE RESISTOR
FMO	OUTDOOR FAN MOTOR	BD	BRIDGE DIODE
49FO	OUTDOOR FAN MOTOR INTERNAL PROTECTOR	C1, C2	CAPACITOR
C1, C2	CAPACITOR	R1, RP, RF, RM	AUXILIARY RELAY
52C	ELECTRO-MAGNETIC CONTACTOR	RCS-36V	CONTROL UNIT
63PH	HIGH PRESSURE SWITCH	SW1	OPERATION ON/OFF SWITCH
INDOOR UNIT		SW2	FAN SPEED SELECTOR SWITCH
LM	AUTO DEFLECTOR MOTOR	SW3	AUTO DEFLECTOR SWITCH
FMI	INDOOR FAN MOTOR	R1, R2	RESISTOR
49FI	INDOOR FAN MOTOR INTERNAL PROTECTOR	LED1, LED2	INDICATOR LAMP
C	CAPACITOR	VR	VARIABLE RESISTOR (THERMOSTAT)

● Electric Wiring Diagram (PCB Ass'y)

V3622 / C3622

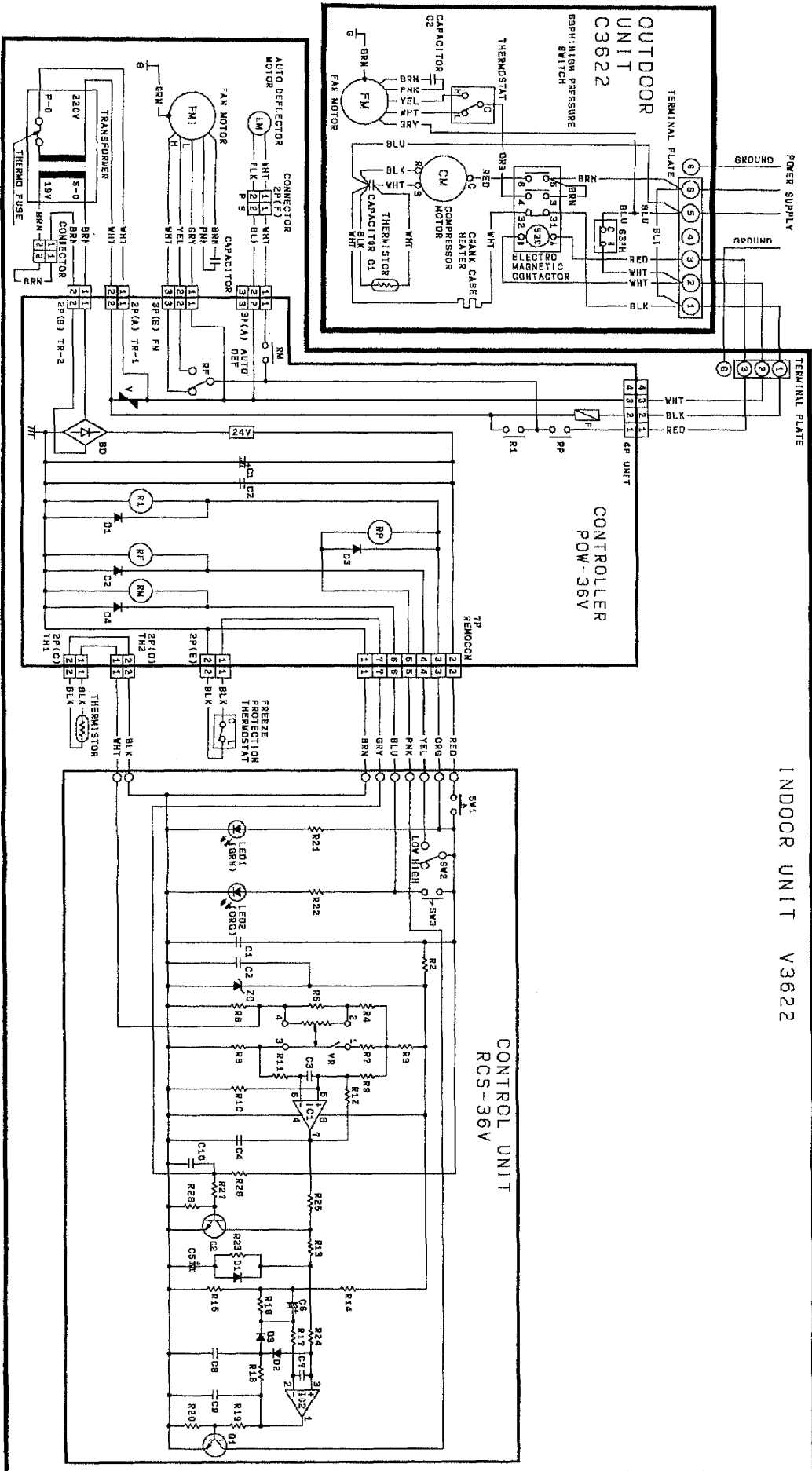



**POW-36V**

Symbol	Description	Specifications
BD	BRIDGE DIODE	DBA-10C
D1	DIODE	DS-442X
D2	DIODE	DS-442X
D3	DIODE	DS-442X
D4	DIODE	DS-442X
C1	CAPACITOR	470 $\mu$ F 50V
C2	CAPACITOR	0.047 $\mu$ F 50V
R1	RELAY	LZG-24HE DC24V
RF	RELAY	LZG-24HE DC24V
RM	RELAY	LZG-24HE DC24V
RP	RELAY	LZG-24HE DC24V
V	VARISTOR	SNR-A420K
7P	CONNECTOR	PLUG E1 (WHT)
4P	CONNECTOR	PLUG ULTLEX (BLK)
3P (A)	CONNECTOR	PLUG ULTLEX (RED)
3P (B)	CONNECTOR	PLUG ULTLEX (BLK)
2P (A)	CONNECTOR	PLUG ULTLEX (BLK)
2P(B)	CONNECTOR	PLUG SL156
2P(C)	CONNECTOR	PLUG 5273-02A
2P (D)	CONNECTOR	PLUG E1 (WHT)
2P (E)	CONNECTOR	PLUG 5273-02A-BL
F	FUSE	250V, 5A

**RCS-36V**

Symbol	Description	Specifications
R2	RESISTOR	680 $\Omega$ 2W
R3	RESISTOR	12K $\Omega$ 1/4W $\pm$ 5%
R4	RESISTOR	3.9K $\Omega$ 1/4W $\pm$ 1%
R5	RESISTOR	820 $\Omega$ 1/4W $\pm$ 1%
R6	RESISTOR	18K $\Omega$ 1/4W $\pm$ 1%
R7	RESISTOR	10K $\Omega$ 1/4W $\pm$ 5%
R8	RESISTOR	560K $\Omega$ 1/4W $\pm$ 5%
R9	RESISTOR	2.94K $\Omega$ 1/4W $\pm$ 1%
R10	RESISTOR	3k $\Omega$ 1/4W $\pm$ 1%
R11	RESISTOR	10K $\Omega$ 1/4W $\pm$ 1%
R12	RESISTOR	910K $\Omega$ 1/4W $\pm$ 1%
R13	RESISTOR	11K $\Omega$ 1/4W $\pm$ 5%
R14	RESISTOR	10K $\Omega$ 1/4W $\pm$ 5%
R15	RESISTOR	2K $\Omega$ 1/4W $\pm$ 5%
R16	RESISTOR	220K $\Omega$ 1/4W $\pm$ 5%
R17	RESISTOR	10K $\Omega$ 1/4W $\pm$ 5%
R18	RESISTOR	4.3K $\Omega$ 1/4W $\pm$ 5%
R19	RESISTOR	6.8K $\Omega$ 1/4W $\pm$ 5%
R20	RESISTOR	2.2K $\Omega$ 1/4W $\pm$ 5%
R21	RESISTOR	1.2K $\Omega$ 1W
R22	RESISTOR	2.4K $\Omega$ 1/2W
R23	RESISTOR	12K $\Omega$ 1/4W $\pm$ 5%
R24	RESISTOR	2.2K $\Omega$ 1/4W $\pm$ 5%
R25	RESISTOR	10K $\Omega$ 1/4W $\pm$ 5%
R26	RESISTOR	1.8K $\Omega$ 1W
R27	RESISTOR	12K $\Omega$ 1/4W $\pm$ 5%
R28	RESISTOR	2K $\Omega$ 1/4W $\pm$ 5%
C1	CAPACITOR	0.047 $\mu$ F 50V
C2	CAPACITOR	0.022 $\mu$ F 50V
C3	CAPACITOR	0.022 $\mu$ F 50V
C4	CAPACITOR	0.022 $\mu$ F 50V
C5	CAPACITOR	4.7 $\mu$ F 16V
C6	CAPACITOR	330 $\mu$ F 10V
C7	CAPACITOR	0.022 $\mu$ F 50V
C8	CAPACITOR	0.047 $\mu$ F 50V
C9	CAPACITOR	0.022 $\mu$ F 50V
C10	CAPACITOR	0.022 $\mu$ F 50V
ZD	ZENER DIODE	GZA 12L
D1	DIODE	DS-442X
D2	DIODE	DS-442X
D3	DIODE	DS-442X
Q1	TRANSISTOR	2SC536KNP E OR F
Q2	TRANSISTOR	2SC536KNP E OR F
VR	SLIDE VOLUME	S4511P-5KBB
SW1	SWITCH	SSSB 22003A
SW2	SWITCH	SPUZ 12009A
SW3	SWITCH	SUH 22V
LED1	LED (GRN)	HLE-G-LTS
LED2	LED (ORG)	HLE-O-LTS
IC	IC	LA6358

## 5. TROUBLESHOOTING

### 5-1 Check before and after troubleshooting.

#### (1) Check power supply wiring.

- Check that power supply wires are correctly connected to terminals No. 5 and No. 6 on the 6P terminal plate in the outdoor unit.

#### (2) Check inter-unit wiring.

- Check that inter-unit wires are correctly connected to indoor unit from outdoor unit.

Power supply:  
60Hz, single-phase, 230/208V

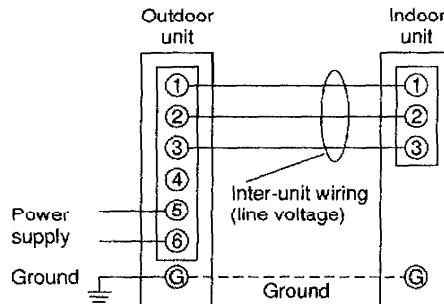

#### (3) Check power supply.

- Check that voltage is in specified range ( $\pm 10\%$  of the rating).
- Check that power is being supplied.



**WARNING:**

If the following troubleshooting must be done with power being supplied, be careful about any uninsulated live part that can cause **ELECTRIC SHOCK**.

#### (4) Check lead wires and connectors in indoor and outdoor units.

- Check that coating of lead wires is not damaged.
- Check that lead wires and connectors are connected firmly.
- Check that wiring is correct.

## 5-2 Air conditioner does not operate.

### (1) Circuit breaker trips (or fuse blows).

(a) When circuit breaker is set to ON, it trips in a few moments (resetting is not possible).

- There is a possibility of ground fault.
- Measure insulation resistance.

If resistance value is  $1M\Omega$  or less, insulation is defective ("NO").

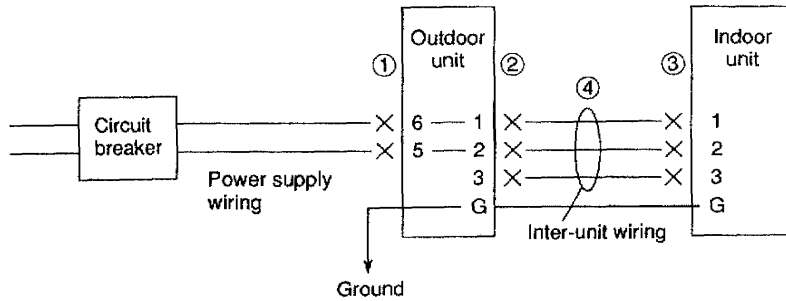

\*Set circuit breaker to OFF.

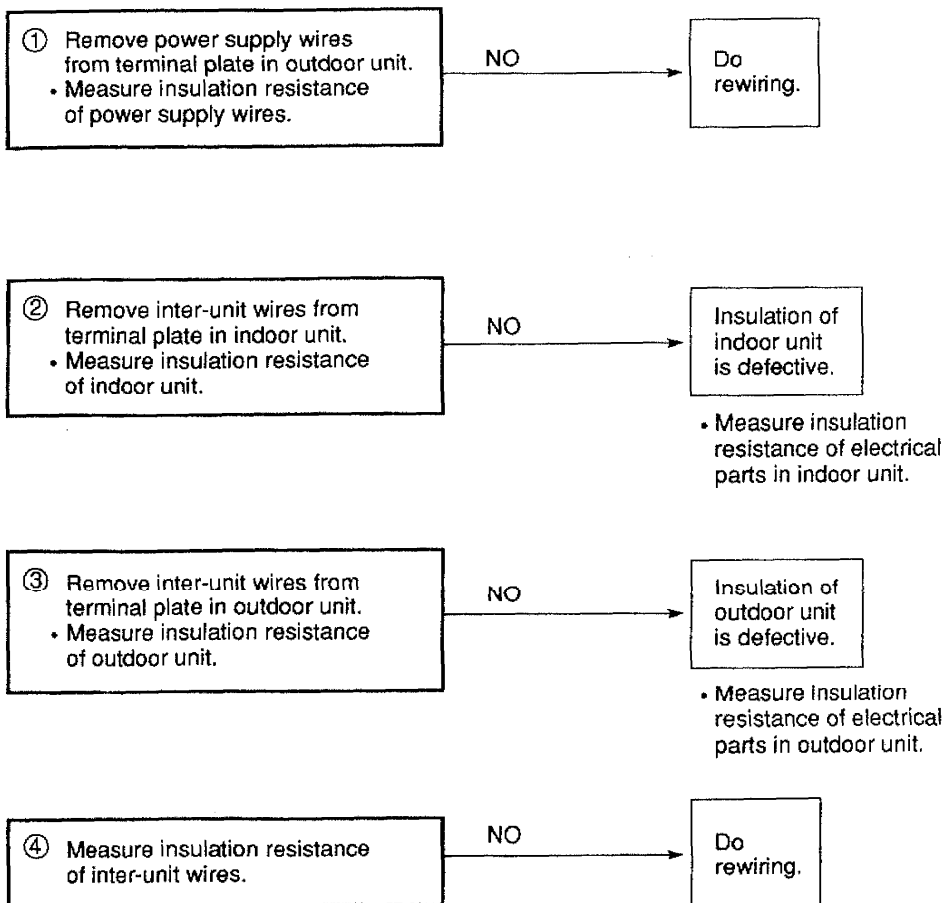

**(b) Circuit breaker trips in several minutes after turning air conditioner ON.**

- There is a possibility of short circuit.

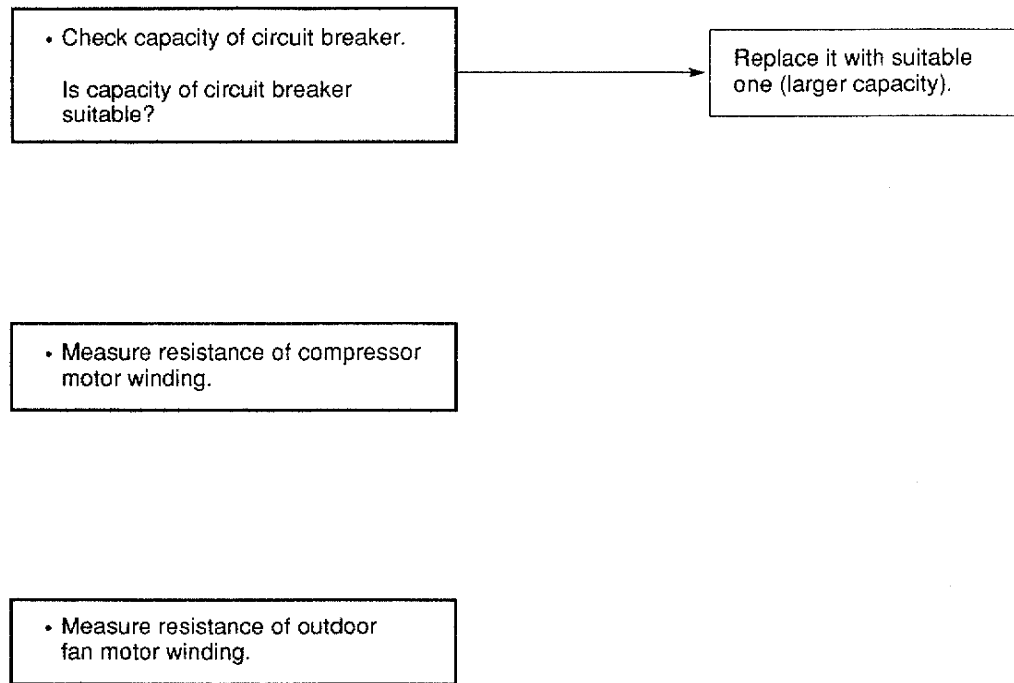

(2) Neither indoor unit nor outdoor unit runs.

(a) Power is not supplied.

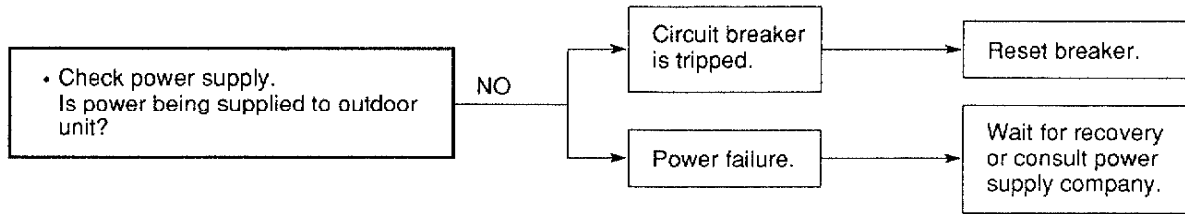

(b) Check fuse on the PCB Ass'y in indoor unit.

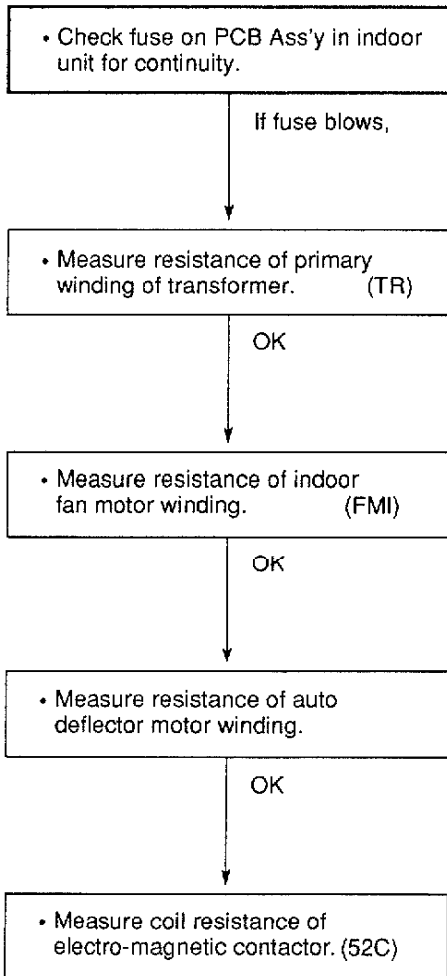

(Neither indoor unit nor outdoor unit runs.) (cont'd)

**(c) Check control unit (RCS-36V).**

Refer to control unit proper.

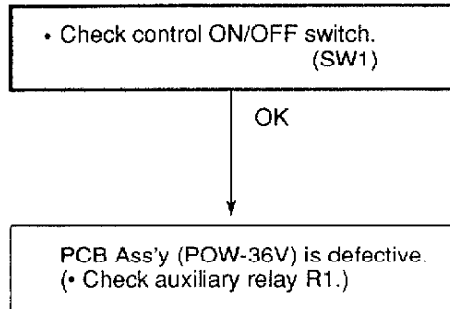

**(d) Check transformer.**

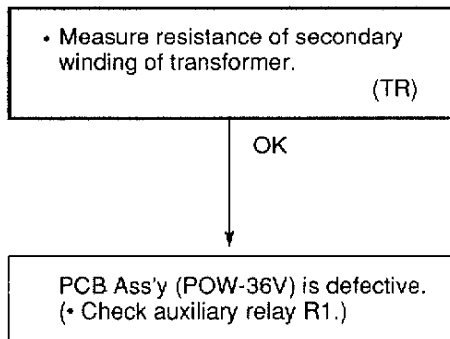

**(e) Check high pressure switch (63PH).**

● System does not run when high pressure switch is operated.

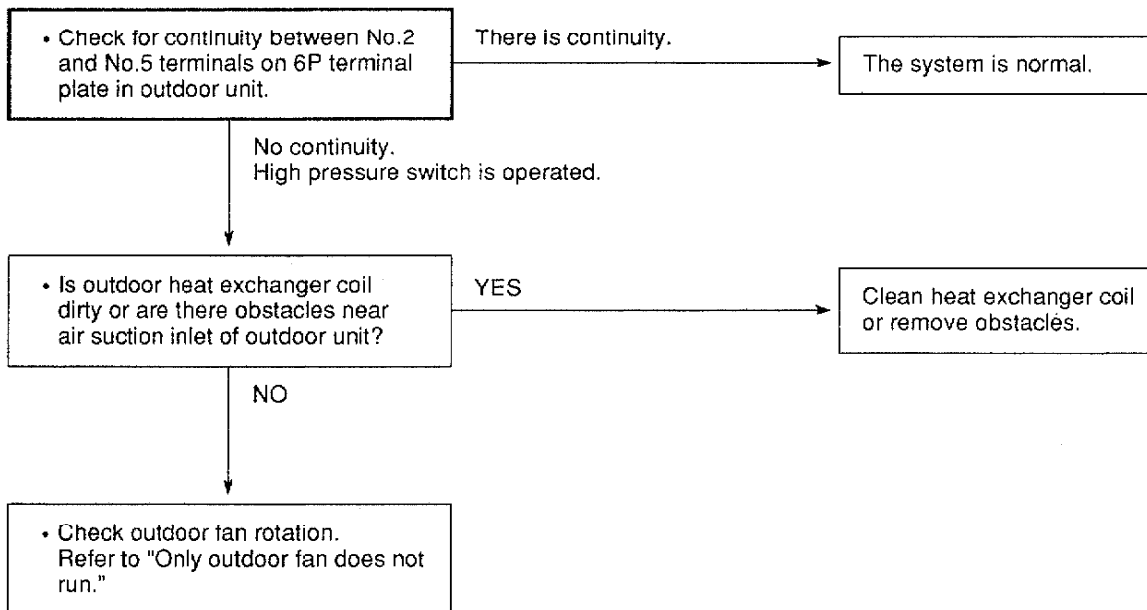

**(3) Only outdoor unit does not run.**

**(a) Outdoor unit does not run when air conditioner is in the following conditions.**

- In thermo OFF (when the room temperature is below the setting temperature).
- In freeze prevention (when the freeze protection thermo is OFF).

**(b) Check electro-magnetic contactor (52C).**

• Measure coil resistance of electro-magnetic contactor.

**(c) Check PCB Ass'y (POW-36V).**

• Measure voltage between No.2 and No.3 terminals on 6P terminal plate in outdoor unit.

No voltage registers.

PCB Ass'y is defective.  
(Check auxiliary relay RP.)

### 5-3 A particular component of air conditioner does not operate.

#### (1) Only indoor fan does not run.

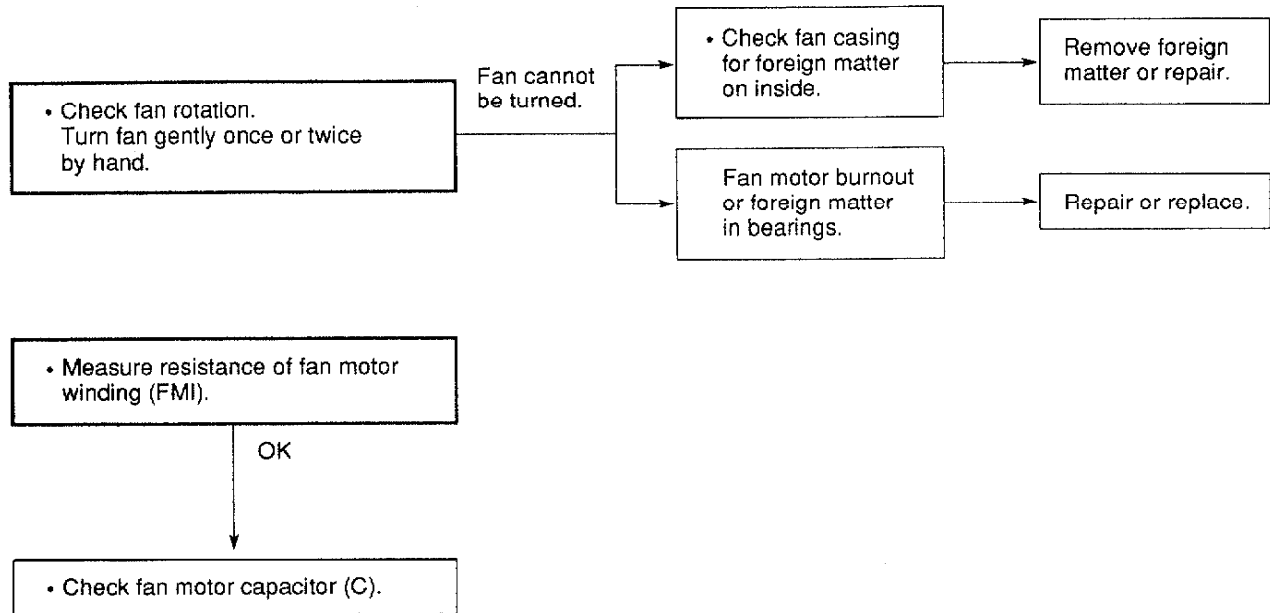



(2) Only outdoor fan does not run.

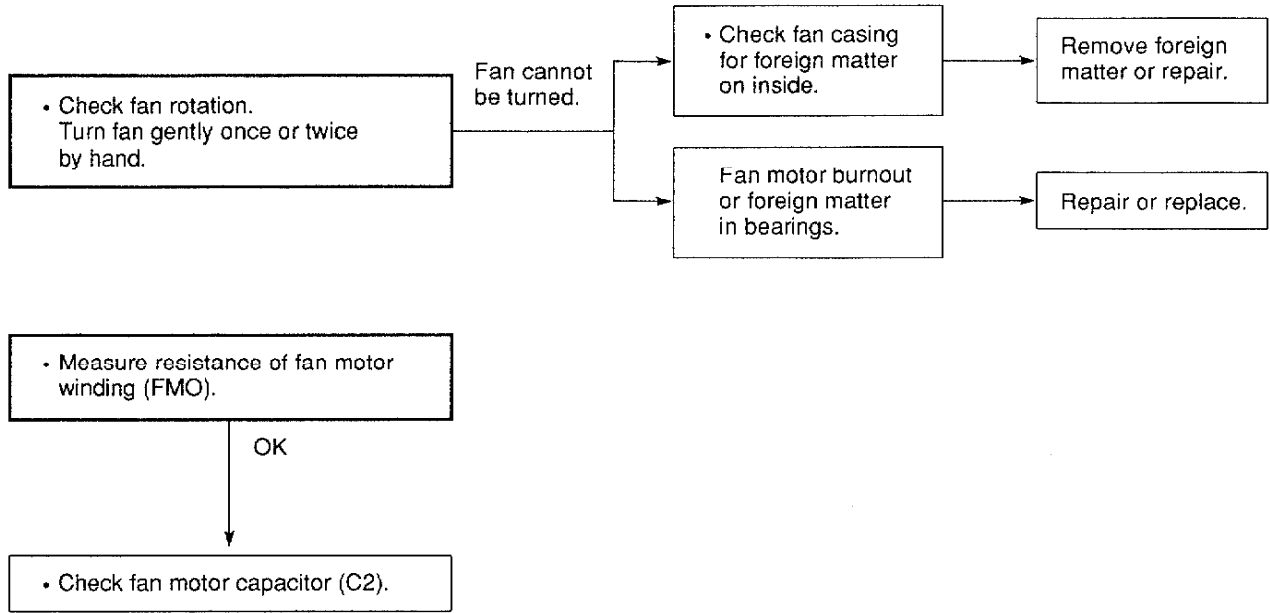

(3) Only compressor does not run.

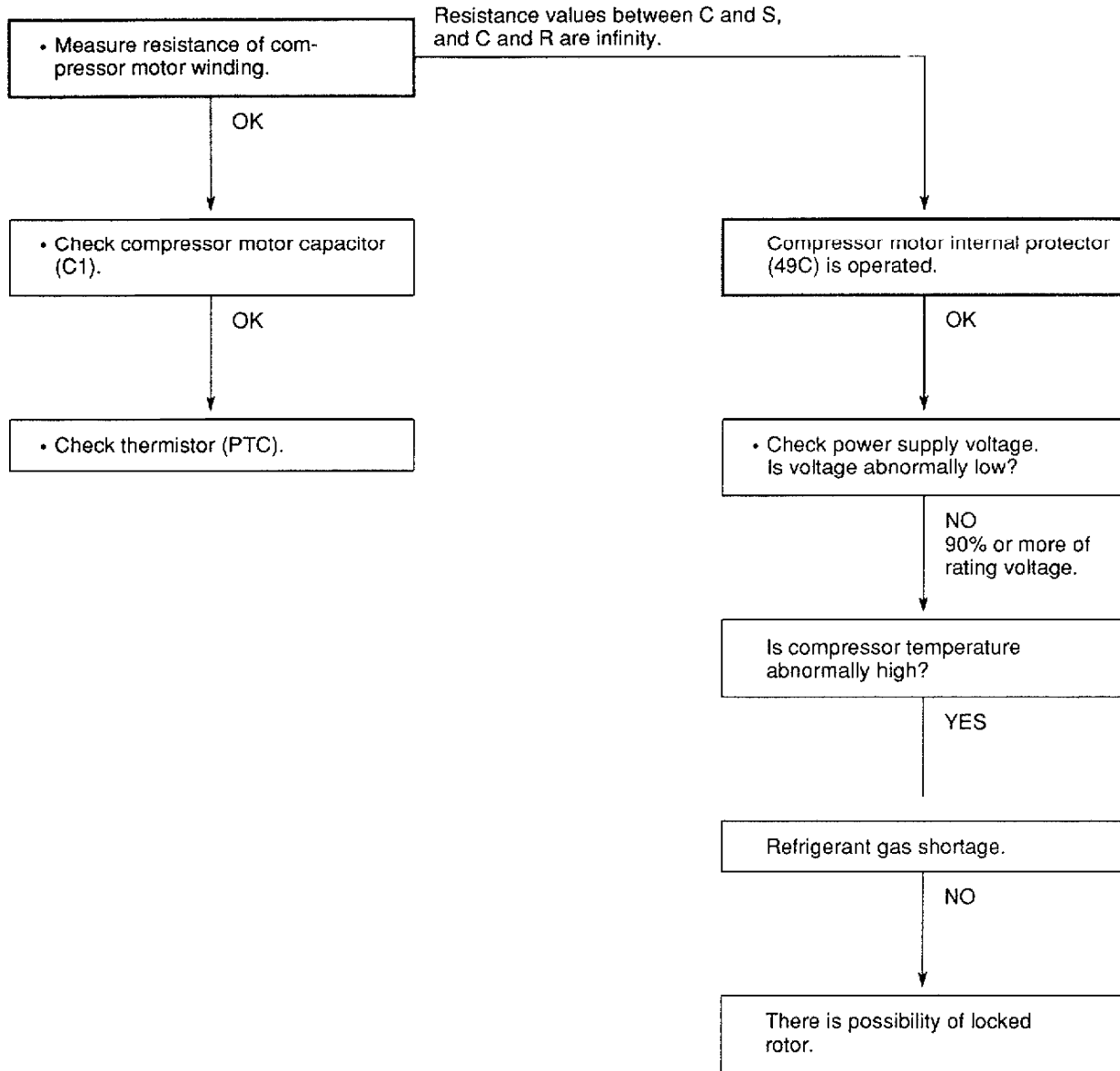

## 5-4 Air conditioner operates, but abnormalities occur.

### (1) Poor Cooling

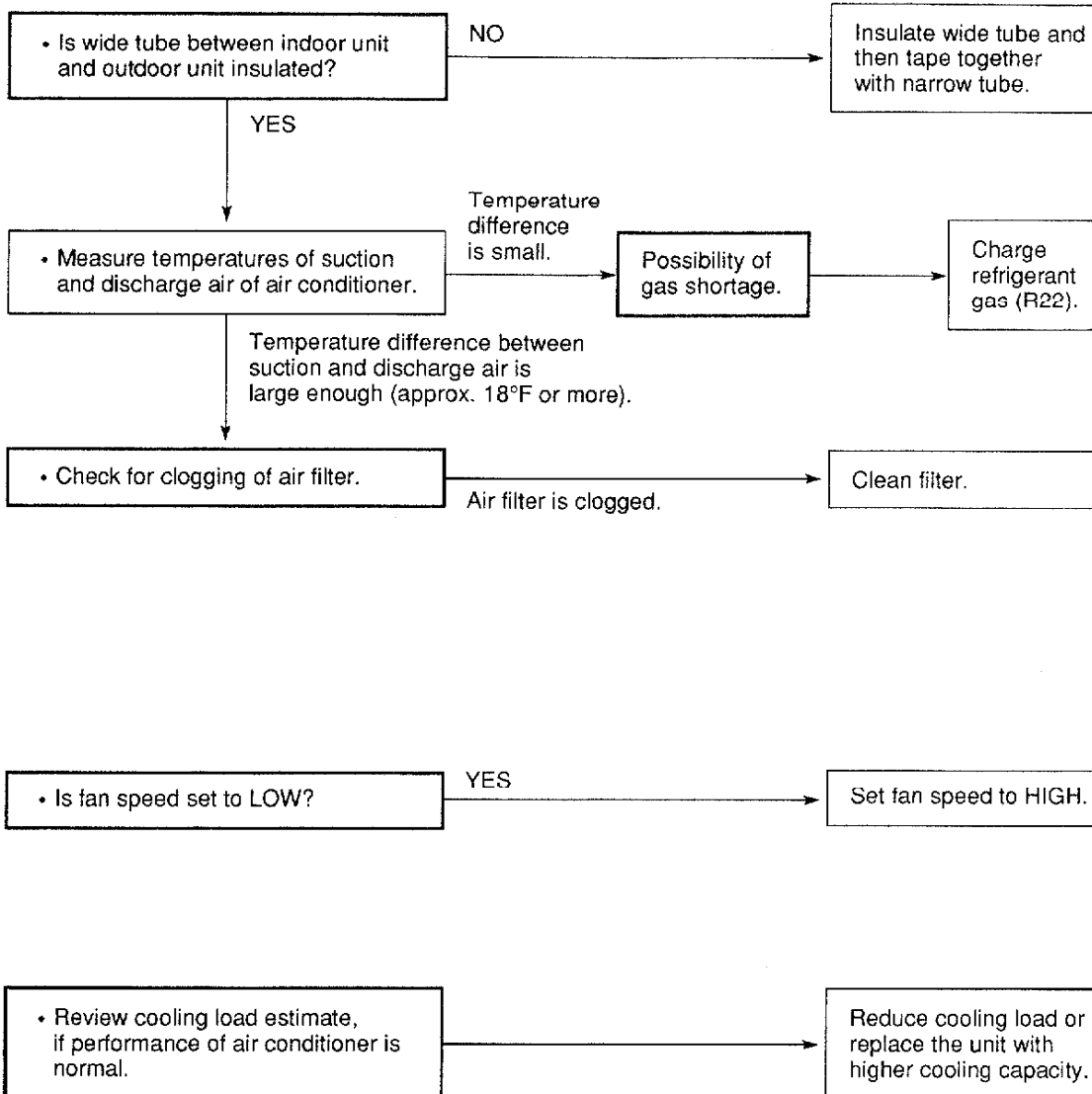

## (2) Excessive Cooling

- Set thermostat knob to suitable position.

TEST RUN position is used for servicing the air conditioner. Do not set it to TEST RUN position during normal operation.

- Check thermistor (THM).

When the thermistor is open, the air conditioner does not stop running until the freeze protection thermostat is operated.

## 6. CHECKING ELECTRICAL COMPONENTS

### 6-1 Measurement of Insulation Resistance

- The insulation is in good condition if the resistance exceeds 1 MΩ.

#### (1) Power Supply Wires

Clamp the grounded wire of the power supply wires with the lead clip of the insulation resistance tester and measure the resistance by placing a probe on either of the power wires. (Fig. 1)

Then measure the resistance between the grounded wire and the other power wires. (Fig. 1)

#### (2) Indoor Unit

Clamp an aluminum plate fin or copper tube with the lead clip of the insulation resistance tester and measure the resistance by placing a probe on ①, and then ② on the terminal plate. (Fig. 2)

#### (3) Outdoor Unit

Clamp a metallic part of the unit with the lead clip of the insulation resistance tester and measure the resistance by placing a probe on ⑤, and then ⑥ on the terminal plate. (Fig. 2)

#### (4) Measurement of Insulation Resistance for Electrical Parts

Disconnect the lead wires of the desired electric part from terminal plate, PCB Ass'y, capacitor, etc. Similarly disconnect the connector. Then measure the insulation resistance. (Figs. 1 to 4)

Refer to Electric Wiring Diagram.

**Note:** If the probe cannot enter the poles because the hole is too narrow then use a probe with a thinner pin.

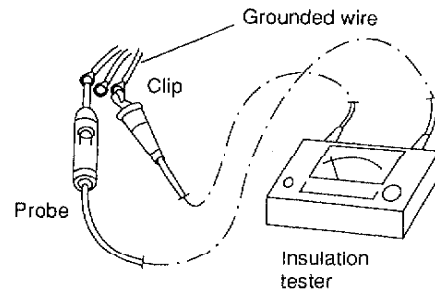

Fig. 1

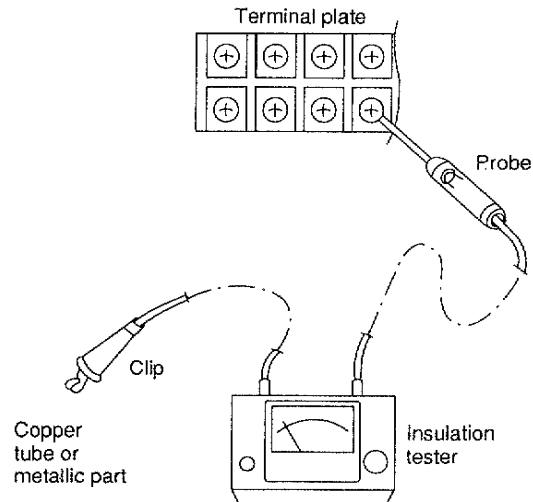

Fig. 2

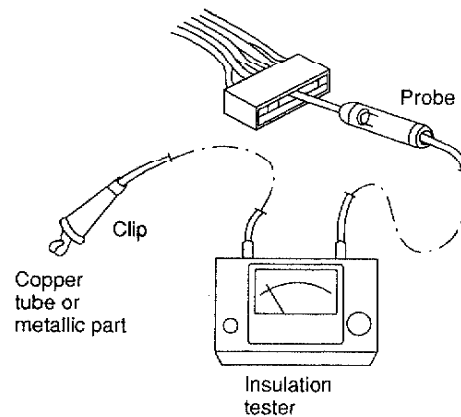

Fig. 3

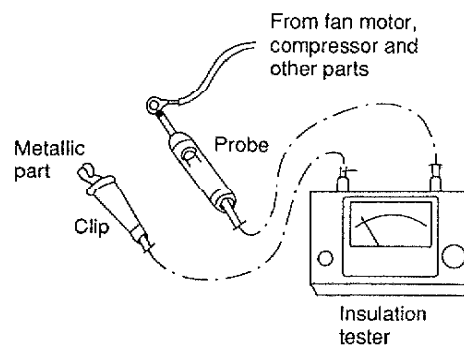

Fig. 4

## 6-2 Checking Continuity of Fuse on PCB Ass'y

- Check for continuity using a multimeter as shown in Fig. 5.

**Note:**

### Method used to Replace Fuse on PCB Ass'y

1. Remove the PCB Ass'y from the electrical component box.
2. Pull out the fuse at the metal clasp using pliers while heating the soldered leads on the back side of the PCB Ass'y with a soldering iron (30W or 60W). (Fig. 6)
3. Remove the fuse ends one by one. For replacement, insert a fuse of the same rating and solder it. (Allow time to radiate heat during soldering so that the fuse does not melt.)



**CAUTION:**

When replacing the fuse, be sure not to break down the varistor.

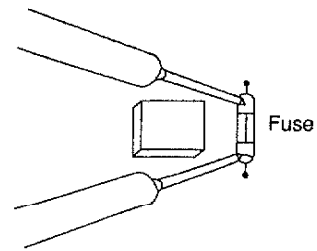

Fig. 5

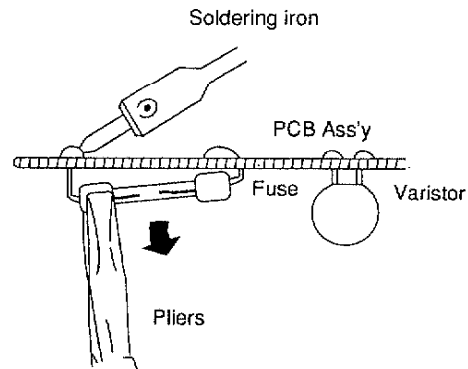

Fig. 6

## 6-3 Checking Motor Capacitor

Remove the lead wires from the capacitor terminals, and then place a probe on the capacitor terminals as shown in Fig. 7. Observe the deflection of the pointer, setting the resistance measuring range of the multimeter to the maximum value.

The capacitor is "good" if the pointer bounces to a great extent and then gradually returns to its original position.

The range of deflection and deflection time differ according to the capacity of the capacitor.

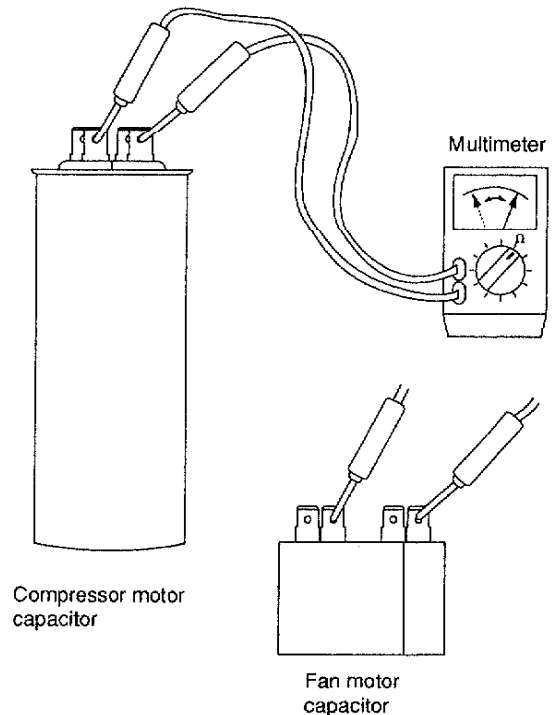

Fig. 7

## 6-4 Checking Control Unit (RCS-36V) Proper

First, pull out the connector (7P) of the remote control unit from the controller (POW-36V) in the indoor unit.

### (1) Checking Operation Switch — SW1

Check the continuity of the terminals between No. 2 and No. 3.

Checking Point	Operation	
	OFF	ON
2 – 3	NO	YES

YES.....Continuity  
NO.....No continuity

### (2) Checking Fan Speed Selector — SW2

Check the continuity of the terminals between No. 3 and No. 4.

Checking Point	Fan Speed	
	High	Low
3 – 4	NO	YES

YES.....Continuity  
NO.....No continuity

### (3) Checking Auto Deflector Switch — SW3

Check the continuity of the terminals between No. 3 and No. 6.

Checking Point	Auto Deflector	
	OFF	ON
3 – 6	NO	YES

YES.....Continuity  
NO.....No continuity

## 6-5 Appearance of Electrical Parts

### (1) Freeze Protection Thermostat

RTB-4U303

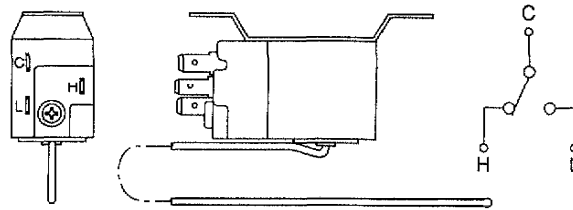

Fig. 8

### (2) High Pressure Switch

FTB-2UC01

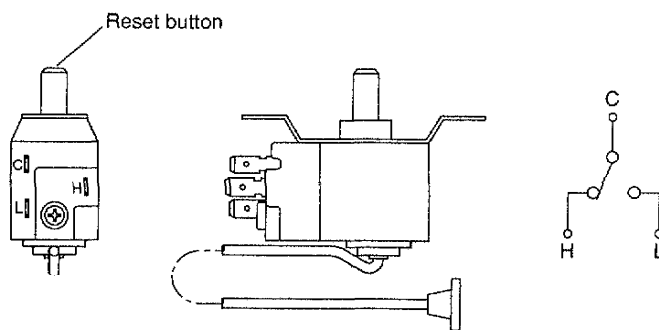

Fig. 9

### (3) Thermistor (PTC)

TDK101YV

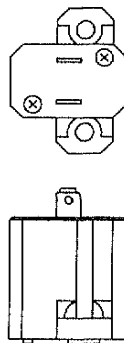

Fig. 10



(4) Electro-Magnetic Contactor

FMCA-1SUL

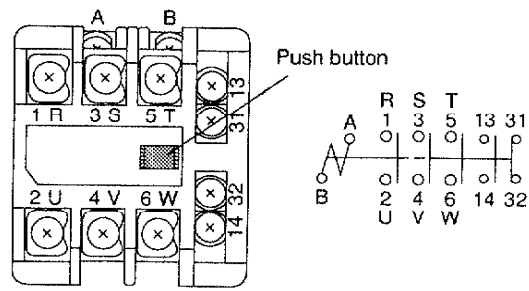

Fig. 11

(5) Thermostat

YTB-4U305F

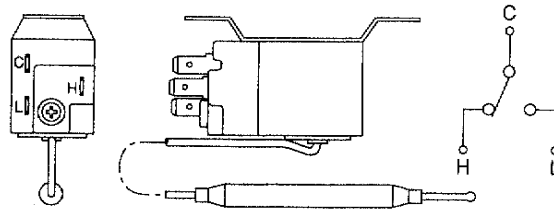

Fig. 12

## Free Manuals Download Website

<http://myh66.com>

<http://usermanuals.us>

<http://www.somanuals.com>

<http://www.4manuals.cc>

<http://www.manual-lib.com>

<http://www.404manual.com>

<http://www.luxmanual.com>

<http://aubethermostatmanual.com>

Golf course search by state

<http://golfingnear.com>

Email search by domain

<http://emailbydomain.com>

Auto manuals search

<http://auto.somanuals.com>

TV manuals search

<http://tv.somanuals.com>