



DCS & Labeling Worldwide

LM Basic (408e/412e)



OPERATOR'S MANUAL



SATO ASIA PACIFIC PTE. LTD.
438A ALEXANDRA ROAD
#05-01/04 ALEXANDRA TECHNOPARK
SINGAPORE 119967
Tel: (65) 6271 5300
Fax: (65) 6273 6011
Sales Hotline: (65) 6276 2722
Service Hotline: (65) 6273 6455
Email: sales@satoasiapacific.com
Website: www.satoworldwide.com

Be sure to ask your dealer about our maintenance contracts
to ensure peace of mind during your usage of SATO products

© Copyright 1994 – 2006
SATO International

Warning: This equipment complies with the requirements in Part 15 of FCC rules for a Class A computing device. Operation of this equipment in a residential area may cause unacceptable interference to radio and TV reception requiring the operator to take whatever steps are necessary to correct the interference.

All rights reserved. No part of this document may be reproduced or issued to third parties in any form whatsoever without the express permission of SATO. The materials in this document are provided for general information and are subject to change without notice. SATO assumes no responsibilities for any errors that may appear.

Version: SI-LM4xxe-01rA-16-01-OM

TABLE OF CONTENTS

1. OVERVIEW	
1.1 General Specifications	1-2
2. INSTALLATION	
Safety Precautions	2-2
2.1 Unpacking	2-4
2.1.1 Included Accessories	2-5
2.1.2 Parts Identification	2-6
2.2 Loading the Carbon Ribbon	2-8
2.3 Loading Labels	2-9
2.3.1 Loading Roll Paper	2-10
2.3.2 Loading Fanfold Paper	2-11
2.3.3 Adjusting the Paper Sensor	2-12
2.4 Replacing the Print Head	2-13
3. CONFIGURATION AND OPERATION	
3.1 Operating Modes	3-1
3.2 The Operation Panel	3-2
3.3 Accessing the Various PRINTER MODES	3-3
3.3.2 Overview of LCD Menu Options In Various Modes	3-5
3.4 NORMAL Modes	3-8
3.4.1 Online	3-8
3.4.2 Offline	3-8
3.4.3 Print Darkness	3-8
3.4.4 Print Speed	3-9
3.4.4 Pitch Offset	3-9
3.4.5 Cancel Print Job	3-9
3.5 ADVANCED Mode	3-10
3.5.1 Advanced	3-10
3.5.2 Darkness Range	3-10
3.5.3 Zero Slash	3-10
3.5.4 Auto Online	3-10
3.5.5 Print Offset	3-10
3.5 Advanced Mode (cont'd)	3-11
3.5.6 Set Calendar	3-11
3.6 SERVICE Mode	3-12
3.6.1 Service	3-12
3.6.2 Slice Level	3-12
3.6.3 Auto Line Feed	3-12
3.6.4 Feed On Error	3-12
3.6.5 Reprint W/Feed	3-12
3.6.6 Forward/Backfeed Amount	3-13

3.6.7 Euro Code	3-13
3.6.8 Select Language	3-13
3.6.9 Command or LCD Priority	3-13
3.6.10 Ignore CAN/DLE	3-13
3.6.11 Ribbon Near End On/Off	3-14
3.6.12 IEEE1284 ACK Signal	3-14
3.6.13 Backfeed Speed	3-14
3.7 COUNTERS Mode	3-15
3.7.1 Counters	3-15
3.7.2 Counter Select	3-15
3.7.3 Show Head Counter	3-15
3.7.4 Clear Head Counter	3-15
3.7.5 Show Life Counter	3-15
3.8 MOVE Mode	3-16
3.8.1 Movements of Labels	3-16
3.8.2 Move Mode	3-16
3.8.3 Pitch Sensor	3-16
3.9 TEST PRINT Mode.....	3-17
3.9.1 Select Test Print	3-17
3.9.2 Test Print Size	3-17
3.9.3 Print Size	3-17
3.9.3 Start/Stop Test Print	3-17
3.10 DEFAULT SETTING Mode	3-18
3.10.1 Resetting the Printer	3-18
3.10.2 Reset Completed	3-18
3.11 Protocol Storing.....	3-19
3.11.1 Protocol Download	3-19
3.11.2 Loading Completed	3-19
3.11.3 Initialization of Protocol Code	3-19
3.12 MAINTENANCE Mode	3-20
3.12.1 Factory or All Clear Mode	3-20
3.12.2 Factory Mode	3-20
3.12.3 Test-Print Width	3-20
3.12.4 Start/Stop Test Print	3-20
3.12.5 All Clear Mode	3-21
3.12.6 Counter/EEPROM clear	3-21
3.12.7 Clear Confirmation	3-21
3.13 HEX DUMP Mode.....	3-22
3.13.1 LCD Status	3-22
3.13.2 Hex Dump Mode in buffer	3-22
3.14 DOWNLOAD Mode	3-23
3.14.1 LCD Status	3-23
3.15 BOOT DOWNLOAD Mode.....	3-24
3.15.1 LCD Status	3-24

TABLE OF CONTENTS (CON'TD)

4. CLEANING AND MAINTENANCE

4.1 Introduction	4-1
4.2 Cleaning The Print Head, Platen and Rollers	4-1
4.3 How To Clean The Printer (With A Cleaning Set)	4-2
4.4 How To Clean The Printer (Cleaning Sheet)	4-3
4.5 Adjusting Print Quality	4-4
4.5.1 <i>Adjusting Print Darkness</i>	4-4
4.5.2 <i>Adjusting Print Speed</i>	4-5
4.6 Replacing A Blown Fuse	4-5

5. INTERFACE SPECIFICATIONS

5.1 Interface types	5-1
5.2 Interface Card DIP SWITCH Settings (RS-232C)	5-2
5.3 Interface Card DIP SWITCH Settings (LAN)	5-3
5.4 Interface Card DIP SWITCH Settings (Wireless LAN)	5-3
5.5 External Signal Interface	5-4
5.6 Serial Interface Specifications (RS-232C)	5-4
5.7 READY/BUSY	5-5
5.8 Single Job Buffer	5-6
5.9 Multi Job Buffer	5-7
5.10 X-ON/X-OFF	5-7
5.11 Single Job Buffer	5-9
5.12 Multi Job Buffer	5-10
5.13 IEEE 1284 Interface	5-11
5.13 Interface Signals	5-13
5.14 Single Job Buffer	5-14
5.15 Multi Job Buffer	5-16

6. TROUBLESHOOTING

6.1 Initial Checklist	6-1
6.2 Using the RS232C (SERIAL) Interface	6-2
6.3 Understanding the LCD Error Messages	6-3
6.4 Troubleshooting Guide	6-4

TABLE OF CONTENTS (CON'TD)

7. OPTIONAL ACCESSORIES

7.1 Introduction	7-1
7.2 Available Interface Boards	7-1
7.3 Optional Accessories: Interface boards	7-2
7.4 Optional Accessories: Others	7-4

1

OVERVIEW

Thank you for your investment in this SATO printer product.

This Operator's Manual contains basic information about the installation, setup, configuration, operation and maintenance of the printer.

A total of seven topics are covered herein, and they are organized as follows:

- Section 1: Overview**
- Section 2: Installation**
- Section 3: Configuration and Operation**
- Section 4: Cleaning and Maintenance**
- Section 5: Interface Specifications**
- Section 6: Troubleshooting**
- Section 7: Optional Accessories**

It is recommended that you become familiar with each section before installing and maintaining the printer. Refer to the **Table Of Contents** at the front of this manual to search for the relevant information needed. All page numbers in this manual consist of a section number followed by the page number within the stated section.

For specialized programming, refer to the separate Programming Manual available from your authorized SATO dealer.

1.1 GENERAL SPECIFICATIONS

The SATO LM 408e and 412e are dual-use (Thermal Transfer and Direct Thermal) high performance labeling solutions designed for logistics and manufacturing sectors. Based mechanically on the field-proven CL ‘enhance’ series, the LM408e and LM412e promise reliable operation and consistent performance at a reasonable cost.

Key features of the two models in the LM Basic series are:

- Low cost 4-inch printer for Logistics and Warehousing
- Backlit two-line 16-character alphanumeric LCD panel
- Clear printing at a fixed resolution of 203dpi/305dpi
- Support for a wide range of I/O interfaces
- Supports SATO Barcode Programming Language for enhanced customizability
- Field-proven label and ribbon path from the acclaimed CL ‘enhance’ series

The two models support all popular barcodes, including 2-D codes. Seven human-readable fonts and two fast and efficient vector fonts, are resident in memory, providing literally thousands of combinations of type styles and sizes.

Key Feature	LM408e and LM412e
Print resolution	203dpi/305dpi
Print method	Thermal Transfer and Direct Thermal
Label sizes supported (using default internal memory)	LM408e: 4 inches (W) by 7 inches LM412e: 4 inches (W) by 7 inches
Label sizes supported	LM408e: 4 inches (W) by 49.2 inches at 203 dpi LM412e: 4 inches (W) by 32.7 inches at 305 dpi
Interfaces available	One of the following interfaces installable upon purchase: High speed RS-232C (25-pin), LAN, USB, IEEE 1284/parallel

1.1 GENERAL SPECIFICATIONS (CONT'D)

Specification	Model LM408e	Model LM412e
Electrical Characteristics		
Print method	Thermal transfer or direct thermal	
Head density	8 dots/ mm (203 dpi)	12 dots/ mm (305 dpi)
Printable Area	W104 mm x pitch 1249 mm (203dpi)	
	(No printing within 3 mm from the inner edge)	
Print speed	2 to 6 inches/sec @203dpi (adjustable in 1-inch/sec increments)	
	Note: Maximum speed depends on print resolution, and may be further dependent on the type of print layout, paper, or carbon ribbon in use.	
CPU	32-bit RISC	
Onboard Memory	Main Memory: 2MB FLASH ROM Expandable Memory: 2x4MB Expandable memory Interface Buffer: 2.95MB for Receive Buffer, "Near Full" warning at 2MB mark.	
Acceptable Print Area	Standard width: 104mm Standard pitch:178mm (Expandable Pitch (using AX command): 356mm	
	(Expandable Pitch (using EX command): 1249mm	(Expandable Pitch (using EX command): 833mm
Memory cartridge	Not accepted	
Print Characteristics		
Print Format	Transmitted from host (computer)	
Paper Thickness	0.08 mm to 0.26 mm supported. Note: Be sure to use only printer supplies manufactured or certified by SATO.	
Paper Size *in continuous mode	Width: 10mm to 112mm (13 mm to 115 mm including liner) Pitch 15mm to 1252mm (18 mm to 1255 mm including liner)	
Label Pitch Sensor	Reflective type (I-mark) and Transmissive type (Gap)	
Carbon ribbon Dimensions Thickness of base material Color Winding direction	Be sure to use the specified carbon ribbons manufactured or specified by SATO W25mm to 111m by 450 m/roll 4.5 µm Black (standard), also red, blue, purple, and green Face-In winding	

Specification	Model LM408e	Model LM412e
Media Characteristics		
Media Types supported	Thermal transfer or direct thermal: 0.08 to 0.26mm Scantrol label, Standard Thermal, Super High Sensitivity Thermal, Logistic Thermal, Synthetic Thermal	
Media Size	Continuous	Width: 22 - 128mm (25 - 131mm) Pitch: 6 - 178mm (9 - 181mm)
	Tear Off	Width: 22 - 128mm (25 - 131mm) Pitch: 20 - 178mm (9 - 181mm)
Media Supply Profile	Roll	Max Outer Diameter Inner Diameter of Roll Wind orientation 8.6 in (210.85mm) 3 in (70.62mm) Face-in
	Fan-fold	Maximum folding height External Supply 100mm Supported
Carbon ribbon	Be sure to use the specified carbon ribbons manufactured or specified by SATO	
Material	Polyester film	
Dimensions	Max width 111mm by 450m length	
Core Inner Diameter	25.6 mm +/- 0.3mm	
Thickness of base material	4.5 to 5.7µm +/-0.5µm (film), 5.8 to 8.3 µm +/- 0.6µm	
Color	Black (standard), also red, blue, purple, and green	
Winding direction	Face-In	

Labels and Ribbons available		
Ribbons		
Type	Wax	T102C, T101A, T104C
	Wax/Resin	T110A, T112D, T123A, T112B, T123B
	Resin	T222A, R335A, R236A, R333A
Labels		
Type	Paper	Vellum, Semi-gloss Coat, Matt Coat, Gloss Coat
	Film	Polyester (PET), Polyethylene (PE, white), Polyethylene (PE, transparent)

1.1 GENERAL SPECIFICATIONS (CONT'D)

Specification/ Model Name		LM408e and LM412e
Interface Characteristics		
External connectivity (Slot 1)	Interface board □ Parallel (IEEE1284) □ RS-232C <ul style="list-style-type: none"> • READY/BUSY • XON/XOFF • Status 2/3 • Driver specific protocol • Status 5 □ USB (Ver. 1.1) □ LAN (10BASE-T/ 100BASE-TX automatic changeover) □ Wireless LAN (IEEE802.11b)	
Configuration and Functions		
User settings (via LCD)	1. Settings indications 2. Print speed 3. Print darkness 4. Print position adjustments 5. Zero slash changeover 6. Proportional pitch adjustments	
Operation Panel	Buttons	LINE, FEED
	Switch	POWER ON/OFF
	LCD	Backlit green LCD, two-line 16-character alphanumeric display
	LED(s)	STATUS
	Adjustment Potentiometers	PITCH: print position adjustment OFFSET: dispense adjustment PRINT: print darkness adjustment
	Other Functions	Status Monitor function Commands for drawing of graphics Sequential numbering Outline and Outline variations Label Skip Line Print Form Overlay Storage of Formats Storage of Customized Font Characters in memory Reverse printing function (White text on a black background) Function for printing of lines and boxes Label format storage function Zero-slash character switching, HEX Dump Print function, Calendar option.
DIP Switches		One 8-bit DIP switch
Programming Language		SATO Barcode Printer Language Ver 4.1
Automatic diagnostics		Head check function (for detection of failed heating elements in the print head) "Paper-End" detection "Head Open" detection Test Print Ribbon End detection Ribbon Near End detection Calendar Check (if optional Calendar chip is installed)

1.1 GENERAL SPECIFICATIONS (CONT'D)

Specification/ Model Name		LM408e and LM412e
Barcoding Functions		
Barcodes Supported	One-dimensional code	<ul style="list-style-type: none"> • UPC-A/E, EAN8/13, JAN8/13 • NW-7 • INTERLEAVED 2 of 5 (ITF) • INDUSTRIAL 2 of 5 • MATRIX 2 of 5 • CODE39, CODE93, CODE128 • UCC/EAN128 • RSS-14 • MSI • POSTNET • BOOKLAND • Customer barcode
	Two-dimensional code	<ul style="list-style-type: none"> • QR code model 2, Micro QR (Ver 8.1) • PDF417 (Ver. 2.4, including micro PDF) • MAXI code (Ver. 3.0) • Data matrix code ECC200 (Ver. 2.0) • Composite Symbols Ver 1.0 (UPC-A/E, EAN8/13, JAN8/13, CODE39, CODE128 CC-A/B/C supported with RSS-14)
Stored Font Types	Standard	XU 5 x 9 dots (alphanumeric, symbol, and kana) XS 17 x 17 dots (alphanumeric, symbol, and kana) XM 24 x 24 dots (alphanumeric, symbol, and kana) XB 48 x 48 dots (alphanumeric, symbol, and kana) XL 48 x 48 dots (alphanumeric, symbol, and kana) Outline font (alphanumeric, symbol, and kana): LM408e: OCR-A 15 x 22 dots (alphanumeric and symbol) OCR-B 20 x 24 dots (alphanumeric and symbol) LM412e: OCR-A 22 x 33 dots (alphanumeric and symbol) OCR-B 30 x 36 dots (alphanumeric and symbol)
	Optional	Kanji ROM fonts: Kanji 16 x 16 (JIS 1st and 2nd standard. Selectable between square Gothic/Mincho) Kanji 24 x 24 (JIS 1st and 2nd standard. Selectable between square Gothic/Mincho)
	Outline (vector)	Alphanumeric, symbol
Print Magnification		Vertical 1 to 12 times, Horizontal 1 to 12 times (characters) L1 to L12 for barcodes
Print Rotation		Characters: 0°, 90°, 180°, and 270° Barcode: Parallel 1 (0°), Serial 1 (90°), Parallel 2 (180°), Serial 2 (270°)
Barcode Ratio		1:2, 1:3, 2:5; Arbitrary user settings allowed
Accessories		
Options		<ul style="list-style-type: none"> • Calendar IC (installed at the factory upon order) • 2MB x 2 Expansion ROM (installed at the factory upon order) • Interface cards including Ethernet, Wireless LAN, High speed RS-232C (25-pin), IEEE1284 and USB (full speed) • Separate 203dpi or 305dpi print head for changing of print resolution

Specification/ Model Name	LM408e and LM412e
Physical Characteristics	
Dimensions	W 430 mm x D 271 mm x H 321 mm (Standard)
Weight	13 Kg (for a standard configuration)
Power Supply	Input voltage: AC100V - 120V or AC200V to 240V \pm 10%
Power Consumption	180 W (peak)
Standards Compliance	CE(NEMCO-GS), UL/c-UL(MET), FCC (Class B), EN55022 (Class B), En61000, CCC, MIC Energy Saving: International Energy Star Program Environmental Conservation: Manufactured according to environment friendly processes In-house equipment level: Class B conformance Package Fall: ISTA-2A
Operating Environment	Operational ambient temperature: 5 to 40 degrees Celsius Operational ambient humidity: 30 to 80% (no condensation) Ambient Storage temperature: -5 to 60 degrees Celsius Ambient Storage humidity: 30 to 90% (no condensation) (Paper, and carbon ribbon excluded)

This page is intentionally left blank

2

INSTALLATION

This section assists you in unpacking and installing the printer from the shipping container. You will also be guided through a familiarization tour of the main parts and controls. The following information is provided:

- Safety Precautions
- Unpacking and Parts Identification
- Loading the Carbon Ribbon
- Loading Labels and Tags
- Adjusting the Sensors
- Replacing the Print Head

SAFETY PRECAUTIONS

Please read the following information carefully before installing and using the printer

THE CAUTION SYMBOL 

Whenever the triangular Caution logo appears in this manual, pay special attention to the warning(s) cited below it. Failure to abide by the warnings may result in injury or damage to property.

PRINTER PLACEMENT TIPS

- Place the printer on a solid, stable, horizontal surface that is not subject to strong vibrations from adjacent mechanical devices. 
- Avoid shaky or slanting tables, or platforms that are liable to collapse under a heavy weight. If the printer is dropped or damaged, immediately turn off the power, pull out the power plug and contact a service center. In this case, continued use of the printer may cause a fire or electric shocks.
- Avoid installing the printer in direct sunlight, or in dusty, very hot or slippery areas. Also avoid placement in damp, unventilated or humid areas. If condensation forms, immediately turn off the power, and do not use the printer until the condensation disappears. Otherwise the moisture may cause electric shocks.
- Avoid placing the printer near large high-current equipment, as such equipment can cause spikes or undervoltages in the power supply.

- Do not leave containers of water or chemicals around the printer. If any liquid is spilled onto the printer, immediately turn off the power, pull out the power cable from the AC outlet, and contact a sales outlet, dealer, or service center. In this case, continued use of the printer may cause fires or electric shocks. 
- Do not move the printer with any paper loaded. The stack of paper may fall off, causing trips and accidents.
- When laying the printer down, be careful not to catch your foot or fingers under it.
- When moving the printer, be sure to pull out the power cable from the AC outlet, and check that any other external interface cables have been disconnected. Otherwise, the connected cables may be damaged, or may cause trips and falls, in addition to or a fire or electric shocks.

ELECTRICAL PRECAUTIONS

- Do not damage, break, or process the power cable. Hanging heavy objects on it, heating or pulling it may damage the power cable and cause fires or electric shocks.
- When the power cable is damaged (cable conductors are exposed or cut, etc.), contact a sales outlet, dealer, or service center. In this case, continued use of the printer may cause fires or electric shocks.
- Do not process, forcibly bend, twist, or pull the power cable. Continued use of such a cable may cause fires or electric shocks.
- If the printer emits any smoke or peculiar odors at any time, turn it OFF and prevent further usage until you have contacted a qualified service personnel.
- Do not use any other voltage except the specified power voltage for the printer that matches your domestic power supply. Otherwise, it may cause fires or electric shocks.

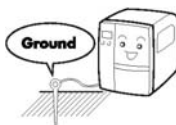
- Do not operate the power switch or handle the power cable with a wet hand.
- Do not insert or drop anything metallic or flammable into the openings of the printer (the cable outlet or mounting hole of the memory cartridge). Otherwise, immediately turn off the power, pull out the power cable, and contact a sales outlet, dealer, or service center. In this case, continued use of the printer may cause fires or electric shocks.
- To reduce electrical risks, be sure to connect the printer to ground before use. Also, try not to share the printer's AC outlet with other electrical equipment, especially those that draw high amounts of current or cause electrical interference. 

GENERAL PRECAUTIONS

- | | |
|---|--|
| <ul style="list-style-type: none"> • Head cleaning liquid (if supplied) is flammable. Never heat it or throw it into a fire. Keep it out of children's reach to avoid accidental consumption. Should this occur, consult a doctor immediately. • When opening/closing the cover, beware of getting your fingers caught. Also, hold the opening/closing cover well so that it will not slip and fall on your hand. • After printing, the print head remains hot. When replacing paper or cleaning the printer immediately after printing, be careful not to burn yourself. • Touching even the edge of the printer head may cause injuries. When replacing paper or cleaning the printer, be careful not to hurt yourself. • If the printer will not be used for extended periods of time, disconnect the power cable for safety. • When releasing and locking down the printer head, be careful not to catch any other foreign matter in it except label paper. | <ul style="list-style-type: none"> • Do not disassemble or perform modifications to the printer, as this renders the product unsafe. For maintenance, troubleshooting and repairs, consult a sales outlet, dealer, or service center for help, instead of attempting to perform this yourself. Renewable annual service contracts are available. • When maintaining or cleaning the printer, always disconnect the power cable for safety. • Do not insert your hand or other objects into the cutter. • When loading roll paper, be careful not to catch your fingers between the paper and the feeder. • Be careful not to hurt yourself when detaching the back cover of the fanfold through the hole and attaching it. • The simplified cutter (where installed) is structured as a blade. Be careful not to cut yourself. |
|---|--|

This equipment is a piece of Class B information technology equipment based on the standards of the Voluntary Control Council for Interference by Information Technology Equipment (VCCI). Although this equipment is for use in home environment, if it is used close to a radio or television set, it may cause poor reception. Handle it properly in accordance with the content from the instruction manual.

SECTION 2: INSTALLATION

2.1 UNPACKING

When unpacking the printer, take note of the following:

1 The box should stay right-side up. Lift the printer out of the box carefully.	4 If the printer was been stored in the cold, allow it to reach room temperature before turning it on.
2 Remove the plastic covering from the printer.	5 Set the printer on a solid, flat surface. Inspect the shipping container and printer for any sign of damage that may have occurred during shipping.
3 Remove the accessory items from their protective containers.	

Note

The following illustrations are representative only. Your printer may not be packed exactly as shown, but the unpacking steps are similar.

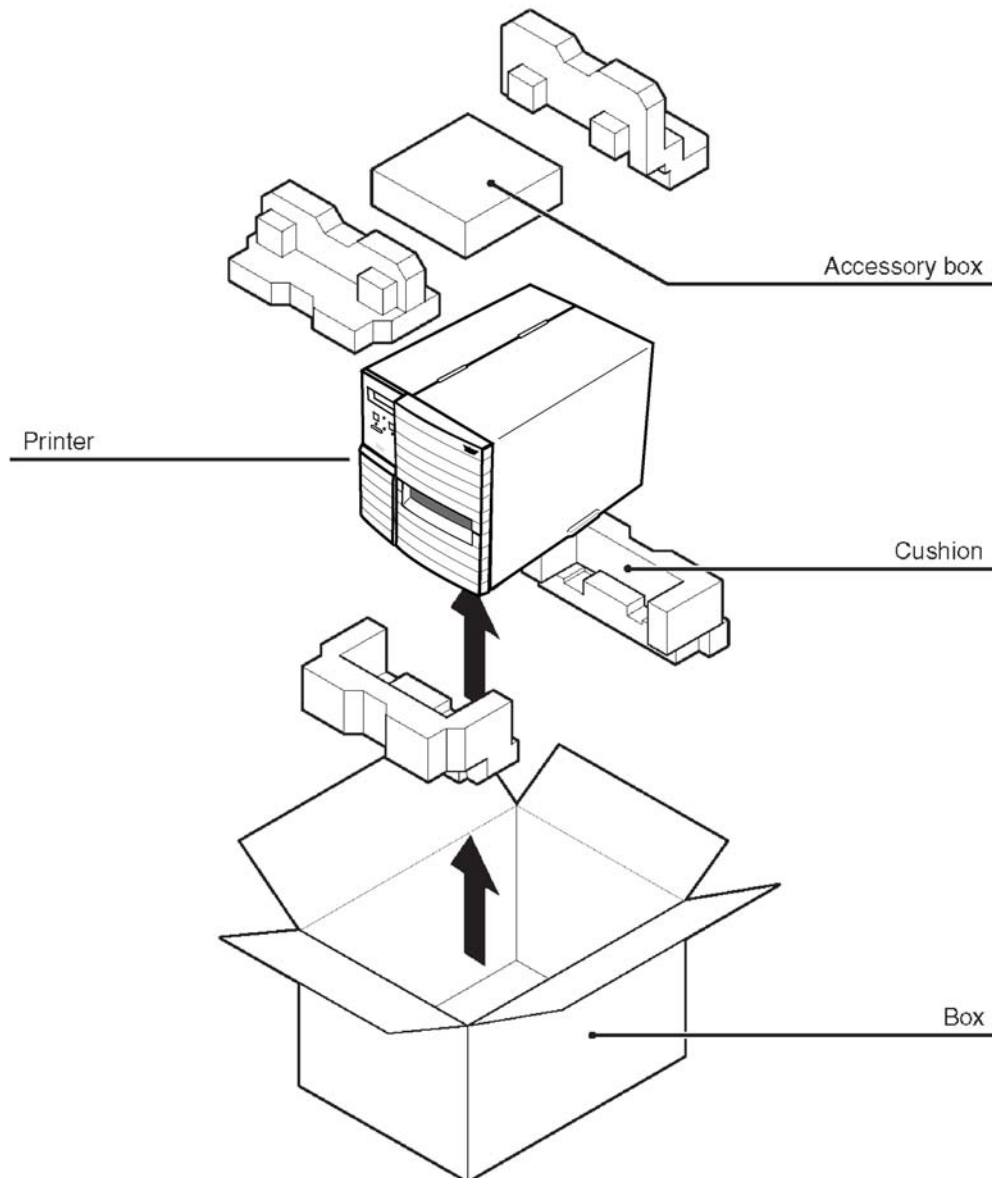

2.1.1 INCLUDED ACCESSORIES

After unpacking the printer, verify that the following materials are in the accessories or packaging:

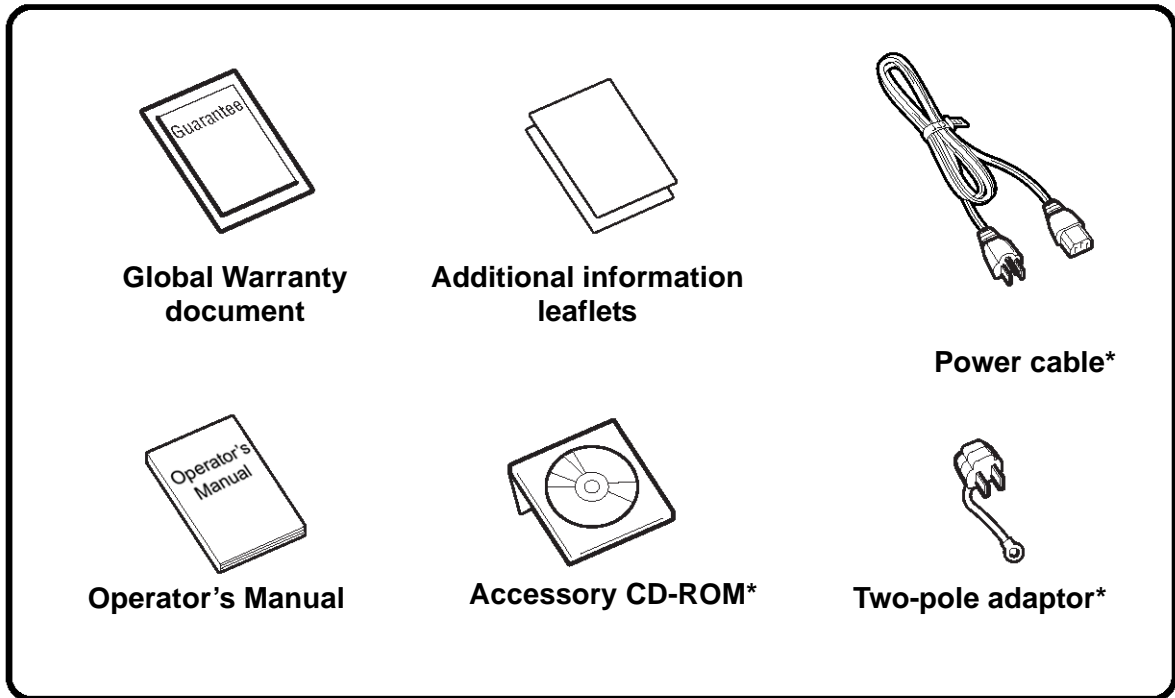

* Items marked with an asterisk may be different from what you see here, or may be excluded.

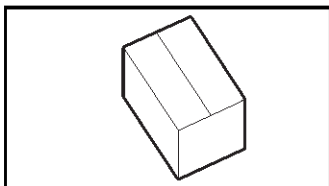

Important!

Please fill out the Global Warranty card and submit it to us in order that we can provide fast and efficient after-sales service. For malfunctions under **normal use**, this product will be repaired free of charge according to the warranty terms applicable for the country of use.

Please do not discard the original packaging box and cushioning material after installing the printer. They may be needed in future, if the printer needs to be shipped for repairs.

SECTION 2: INSTALLATION

2.1.2 PARTS IDENTIFICATION

IDENTIFYING THE MAIN PRINTER PARTS

Front and Rear View



Angled Front View (Main Cover removed)

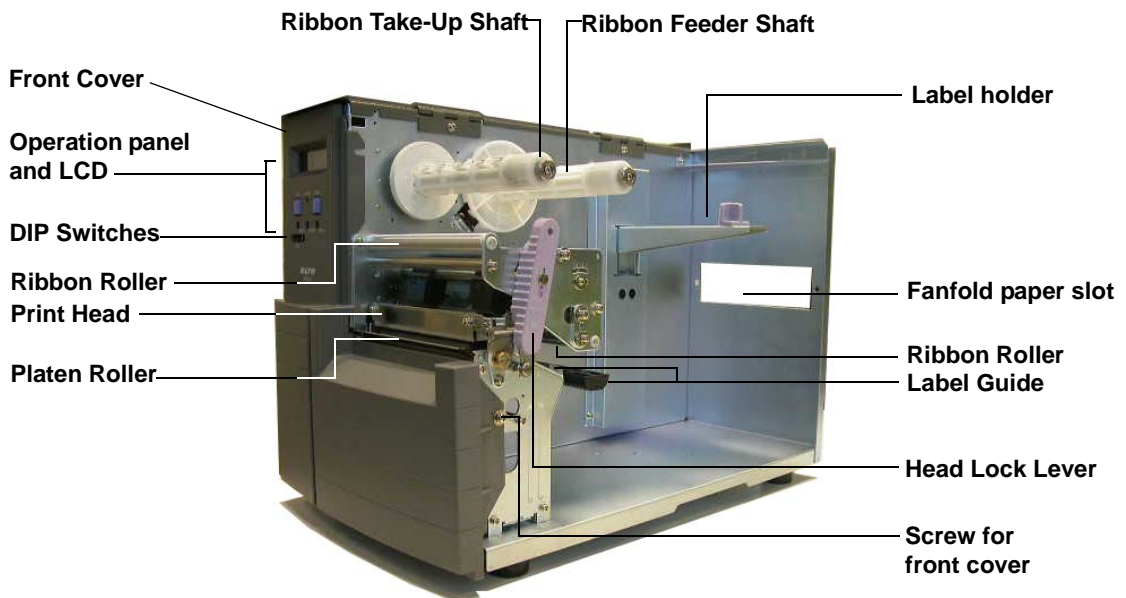

2.1.2 PARTS IDENTIFICATION (CONT'D)

IDENTIFYING THE MAIN PRINTER PARTS

View of Front Panel

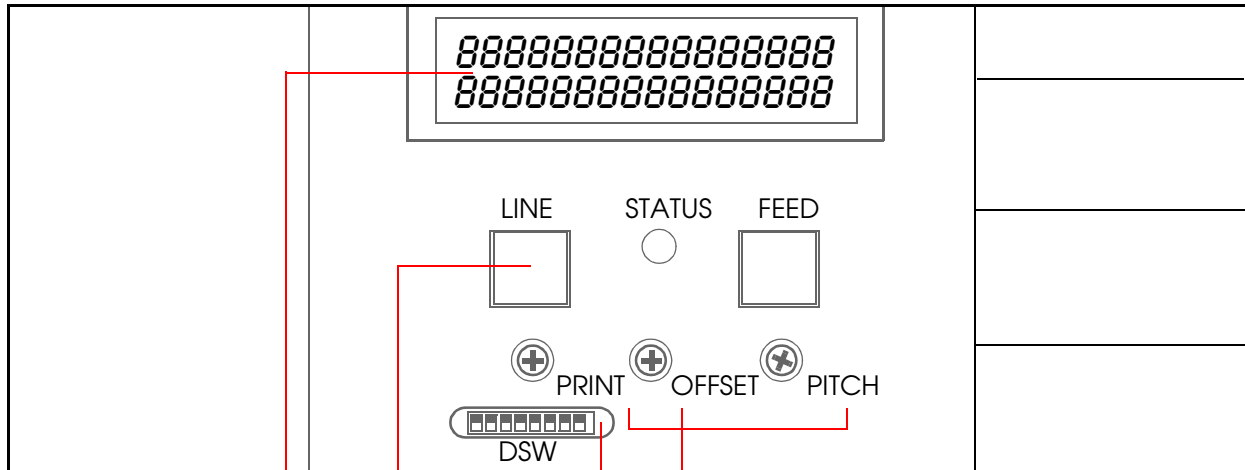

LCD screen

Icons, prompts and system messages are displayed here.

LINE button

Takes the printer ONLINE (to proceed with printing) or OFFLINE (to perform configuration or other settings)

Status LED

Lights up and flashes to indicate exchange of data.

DIP switch panel

FEED button

Feeds the label forward. When it is pressed once, the equivalent of a sheet of paper or label is ejected.
**There are times when the paper is not aligned properly when power is turned on or when the paper was set. In this case, always press the FEED button to align the paper properly.*

Adjustment Potentiometers

PRINT: Adjusts the print darkness (print density).

OFFSET: Adjusts the stop position offset values for the cutter, peeler and tear off modes (cutter, peeler must be installed).

PITCH: Adjusts the vertical print position with reference to the top edge of a label.

No.	Function	Explanation
1	Print method setting	ON : Direct thermal OFF : Thermal transfer
2	Sensor type setting	ON : I-mark sensor OFF : Gap sensor
3	Head check	ON : ON OFF : OFF
4	HEX dump	ON : Valid OFF : Invalid
5	Receive mode ¹ (interface condition)	ON : Multi buffer (periodic response) OFF : 1 item buffer (ENQ response)
6	Download mode	ON : ON OFF : OFF
7	Specify control code	ON : ON OFF : OFF (standard code)
8	Print resolution	ON : 305dpi OFF : 203dpi

¹ When using LAN interface board, setting will be the one inside bracket, (). Refer to Chapter 5: Interface Specifications for details

SECTION 2: INSTALLATION

2.2 LOADING THE CARBON RIBBON

1. Lift up the main cover. Make sure that the cover is pushed upwards until it rests firmly on top of the printer, in case it falls downwards and injures you.

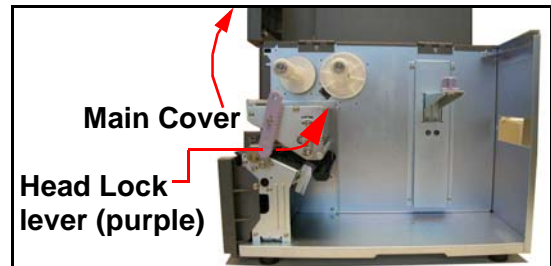

2. Pull the purple Head Lock lever upwards in a counterclockwise direction. The print head assembly will be lifted up to allow ribbon loading. The rightmost white plastic shaft is the Ribbon Feeder Shaft. The left-most shaft is the Ribbon Take-Up Shaft.

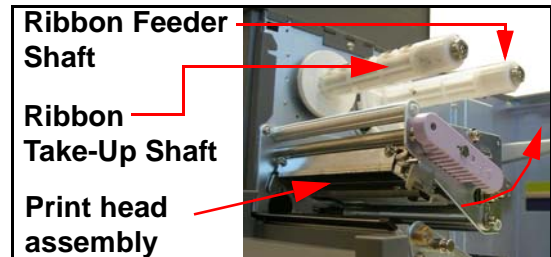

3. Insert the carbon ribbon in the Ribbon Feeder shaft. Push the ribbon roll inwards all the way, with the ribbon winding in a counterclockwise direction, as shown. Pull the ribbon around the print head assembly so it reaches the Ribbon Take-up Shaft. The dull side of the ribbon should be facing down.

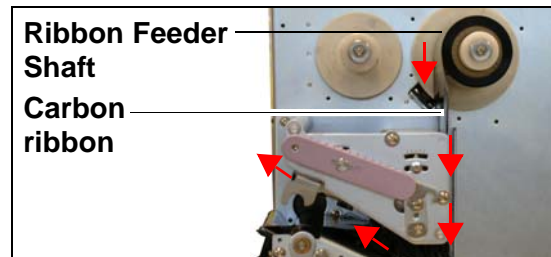

4. Insert an empty ribbon core into the Ribbon Take-Up Shaft. If necessary, use secure the ribbon with adhesive tape, and wind the ribbon around the core a few times.

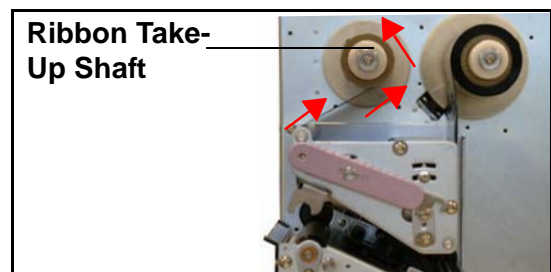

Note:

If in doubt about the ribbon path, refer to the useful diagram pasted inside the Main Cover.

5. Press the purple Head Lock lever clockwise and downwards to lock the print head assembly into place. The ribbon is now loaded.

Note:

To remove the ribbon, reverse the steps described here. For maximum print quality and printer durability use genuine SATO carbon ribbons.

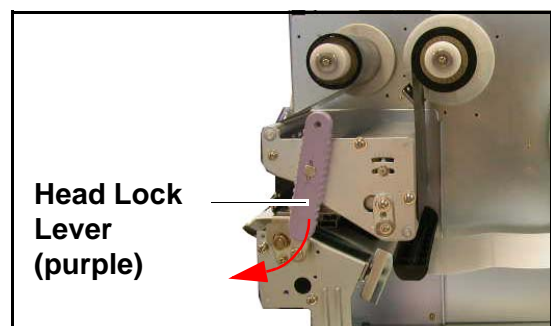

 **Caution**

- When replacing the carbon ribbon, bear in mind that the print head and its surrounding area remain hot. Keep your fingers away from these areas to prevent injury.
- Avoid touching even the edge of the print head with your bare hands.

2.3 LOADING LABELS

This printer is designed to print on **roll paper** supplied via a separate label supply stand. The printing mechanism can be set to detect the I-mark on the paper to feed each label correctly.

Note:

For optimal print performance and durability, **please use SATO-certified label and ribbon supplies on this printer.** Using supplies not tested and approved for use by SATO can result in unnecessary wear and damage to vital parts of the printer, and may void the warranty.

Roll Paper Characteristics

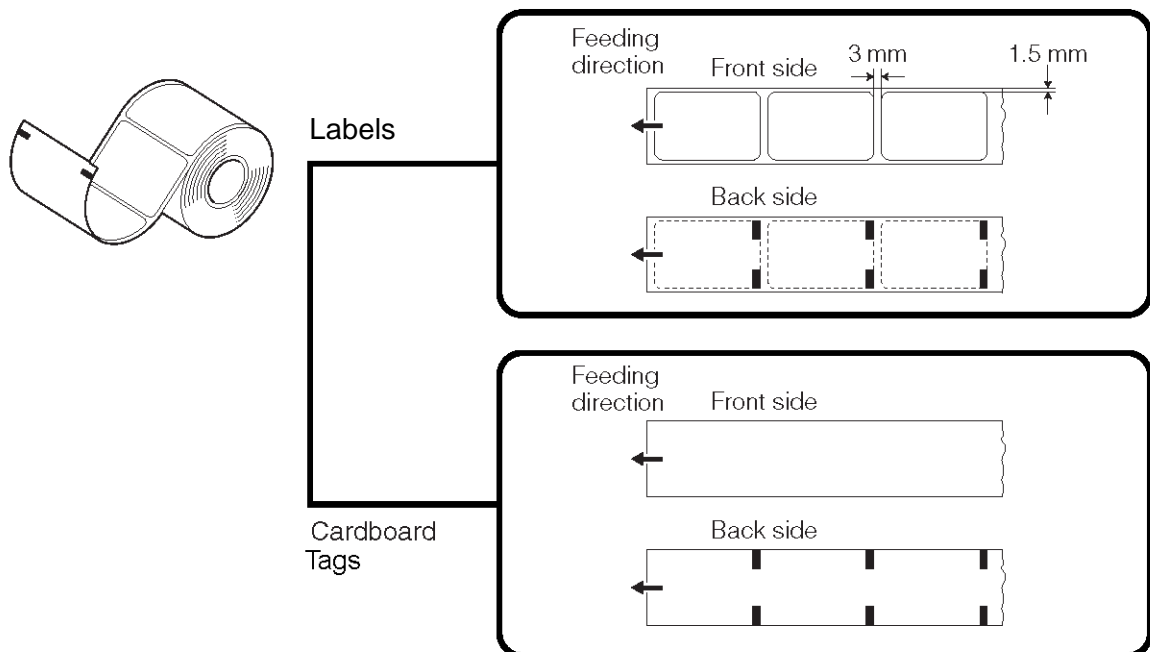

CAUTION

If your labels are less than the full width of the print head, the outside edge will eventually wear out a small portion of the print head, resulting in an area that will not print. Special care must be taken if you plan to use multiple widths of labels, since the damaged portion of the print head caused from edge wear on a more narrow label may affect the printing on a wider label. We suggest you plan your print formats carefully to avoid using the area of possible damage on the print head when using a wider label. The small area of damage will have no effect on printing with the undamaged part of the print head.

Damage from a label edge is physical damage and is unavoidable. It is not covered by warranty. It is possible to delay such damage by always ensuring that the ribbon used is wider than the label stock. This will help to protect the print head from label edge damage.

SECTION 2: INSTALLATION

2.3 LOADING LABELS (CONT'D)

2.3.1 Loading Roll Paper

1. Lift up the main cover. Make sure that the cover is pushed upwards until it locks firmly in place so that it will not fall downwards and injure your hands. Release the purple Head Lock lever by pushing it upwards. The print head assembly will be lifted up to allow ribbon and label loading.

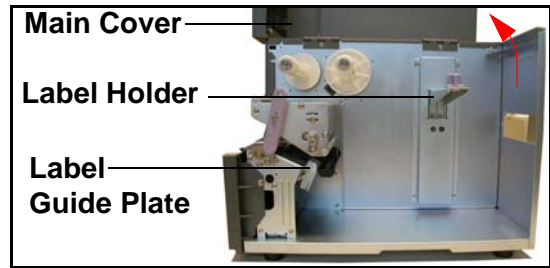

2. Load the ribbon rolls as described earlier. Pull down the Label Guide Plate. Then insert a label roll onto the Label Holder. Push the purple Label Stopper against the label roll to prevent it from slipping sideways.

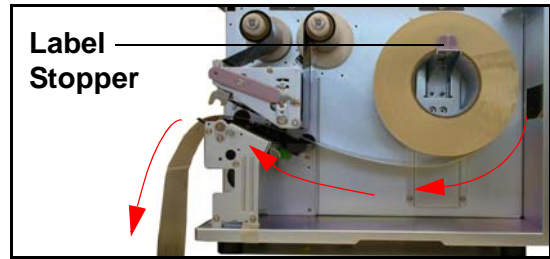

3. Guide the label under the ribbon, making sure it goes under the paper sensors. The label should emerge at a perpendicular angle from the print head.

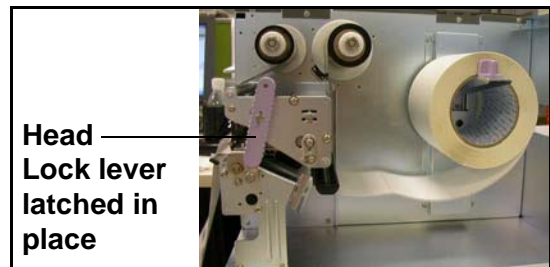

4. Fasten the Head Lock Lever by pushing it clockwise until the print head locks into place. Pull up the Label Guide Plate to and push it against the outside edge of the label to restrict and straighten the label path. Now turn the purple Head Lock Lever clockwise to latch the print head assembly back in place.

5. The illustration below summarizes the ribbon and label loading paths for your reference. To check whether your ribbon and label are loading correctly, perform a test print.

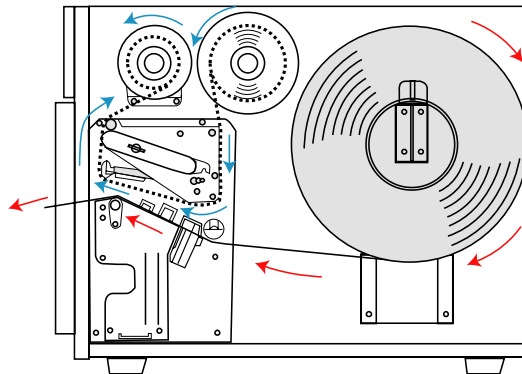

Caution

- When replacing paper, bear in mind that the print head and its surrounding area remain hot. Keep your fingers away from these areas to prevent injury.
- Avoid touching even the edge of the print head with your bare hands.

2.3 LOADING LABELS (CONT'D)

2.3.2 Loading Fanfold Paper

1. Lift up the main cover. Make sure that the cover is pushed upwards until it locks firmly in place. Remove the fanfold slot cover by removing two screws. Pull the Head Lock Lever upward to release the print head assembly.

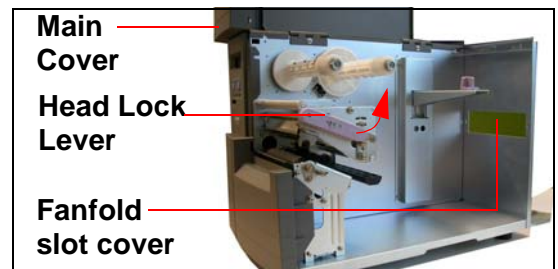

2. Stack the fanfold paper behind the printer and pull it through the fanfold slot and over the Label Holder. Push the purple Label Stopper so that it presses the label lightly against the side of the printer.

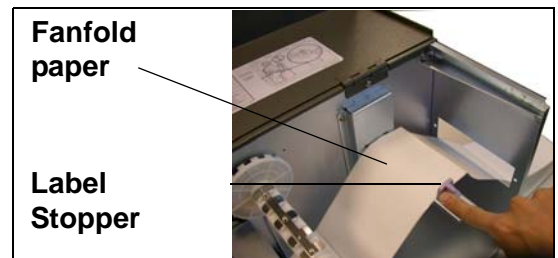

3. Guide the label under the label sensor and print head, and out through the front of the printer. Make sure the label goes under the black plastic guide bar adjacent to the Label Guide.

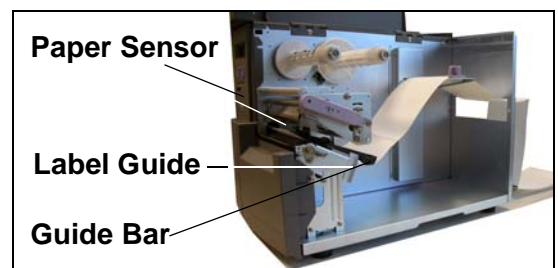

4. Use the metal plate of the Label Guide to press against the paper so that the paper runs at a perpendicular angle from the print head.

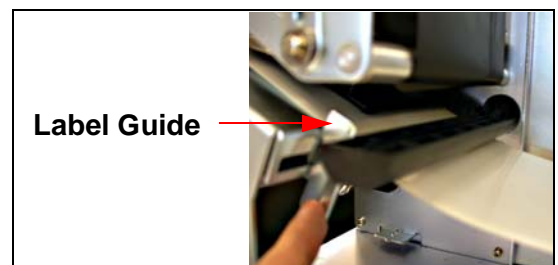

5. Load ribbon media and labels, then turn the purple Head Lock Lever clockwise to latch the print head assembly back in place. and perform a test print to check whether your ribbon and label are loaded correctly.

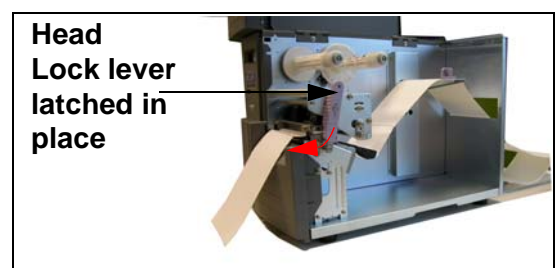

Caution

- When replacing paper, bear in mind that the print head and its surrounding area remain hot. Keep your fingers away from these areas to prevent injury.
- Avoid touching even the edge of the print head with your bare hands.

SECTION 2: INSTALLATION

2.3 LOADING LABELS AND TAGS (CONT'D)

2.3.3 Adjusting the Paper Sensor

Adjustment of the paper sensors (I-mark and Gap sensors) is usually not necessary, but the procedure is described here when you need to make adjustments.

1. Lift up the main cover. Make sure that the cover is pushed upwards until it locks firmly in place so that it will not fall downwards and injure your hands.
2. The sensor assembly is located just under the Label Guide Shaft. Turn the purple Sensor Adjustment knob to adjust the sensors' position.
3. After adjustment, feed a few labels and do a test print to see if the sensor is working properly. Adjust the label pitch if necessary.

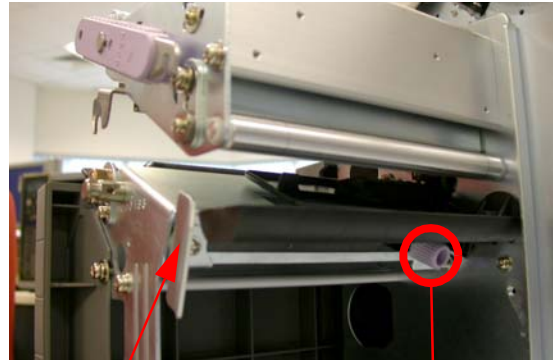

Label Guide Plate

Sensor Adjustment knob

Caution

- When closing the front cover, be careful not to injure your fingers due to a sudden release of the heavy cover.

2.4 REPLACING THE PRINT HEAD

Before attempting to replace the print head, it is advisable to contact your local dealer or service center so that they can assist you in case of problems.

1. Make sure the printer has been turned off for at least 30 minutes so that the print head is not hot. Lift up the front cover.

2. Locate the center screw that secures the print head, as shown in the picture. Unscrew it so that the print head comes loose.



3. Push the Head Lock Lever (the purple slide lever) upwards. in the direction shown here.



4. Pull the print head outwards and disconnect the two connectors attached to it.

Caution

- Do not touch the print head's heating elements. If you do so inadvertently, use the cleaning pen (supplied) to clean the area thoroughly. For more details, see Section 4, Cleaning and Maintenance.

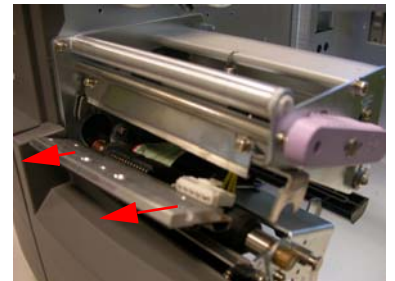

5. Insert the replacement print head and connect the two connectors to it.

6. Mount the print head back into the original location and remount the center screw that secures it.

7. Turn the Head Lock Lever clockwise and lock the print head assembly in place.

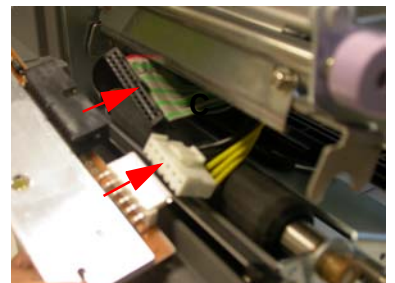

SECTION 2: INSTALLATION

This page is intentionally left blank

3

CONFIGURATION AND OPERATION

Before using the printer, it is best to read this manual thoroughly first. Otherwise, you may disturb default settings around which the instructional procedures in this manual are based on.

3.1 OPERATING MODES

The operating status of this printer can be set to one of nine modes:

- 1) Normal (Online and Offline) Modes
- 2) Advanced Mode
- 3) Service Mode
- 4) Counters Mode
- 5) Move Mode
- 6) Test Print Mode
- 7) Maintenance (Factory/All Clear) Mode
- 8) Boot Download Mode
- 9) Hex Dump Mode

The different modes are accessed through a combination of setting DIP switches and holding down certain buttons on the Operation Panel when you turn the printer ON. These are explained in the following sections.

Note

Due to SATO's continual efforts to improve the printer firmware and hardware, the sequence and availability of LCD menus described here may not be similar to what is available on your version of LM Basic. In this case, visit SATO's website at <http://www.satoworldwide.com> for supplementary and updated documentation.

3.2 THE OPERATION PANEL

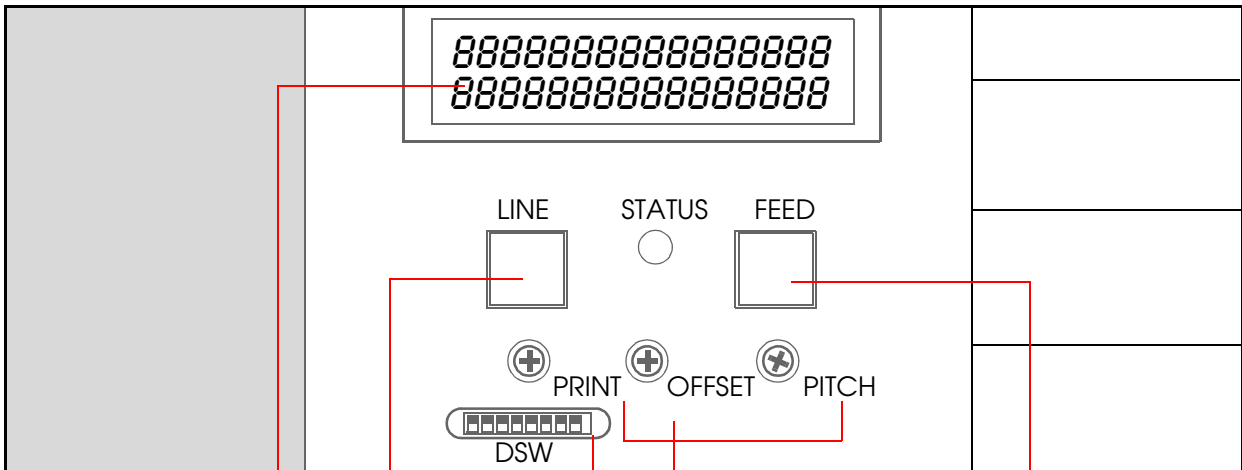

LCD screen

Icons, prompts and system messages are displayed here.

LINE button

Takes the printer ONLINE (to proceed with printing) or OFFLINE (to perform configuration or other settings)

Status LED

Lights up and flashes to indicate exchange of data.

DIP switch panel

No.	Function	Explanation
1	Print method setting	ON : Direct thermal OFF : Thermal transfer
2	Sensor type setting	ON : I-mark sensor OFF : Gap sensor
3	Head check	ON : ON OFF : OFF
4	HEX dump	ON : Valid OFF : Invalid
5	Receive mode ¹ (interface condition)	ON : Multi buffer (periodic response) OFF : 1 item buffer (ENQ response)
6	Download mode	ON : ON OFF : OFF
7	Specify control code	ON : ON OFF : OFF (standard code)
8	Print resolution	ON : 305dpi OFF : 203dpi

¹ When using LAN interface board, setting will be the one inside bracket, (). Refer to Chapter 5: Interface Specifications for details

FEED button

Feeds the label forward. When it is pressed once, the equivalent of a sheet of paper or label is ejected.
*There are times when the paper is not aligned properly when power is turned on or when the paper was set. In this case, always press the FEED button to align the paper properly.

Adjustment Potentiometers

PRINT: Adjusts the print darkness (print density).

OFFSET: Adjusts the stop position offset values for the cutter, peeler and tear off modes (cutter, peeler must be installed).

PITCH: Adjusts the vertical print position with reference to the top edge of a label.

3.3 ACCESSING THE VARIOUS PRINTER MODES

The chart below provides an overview of the way to access the different modes of the printer.

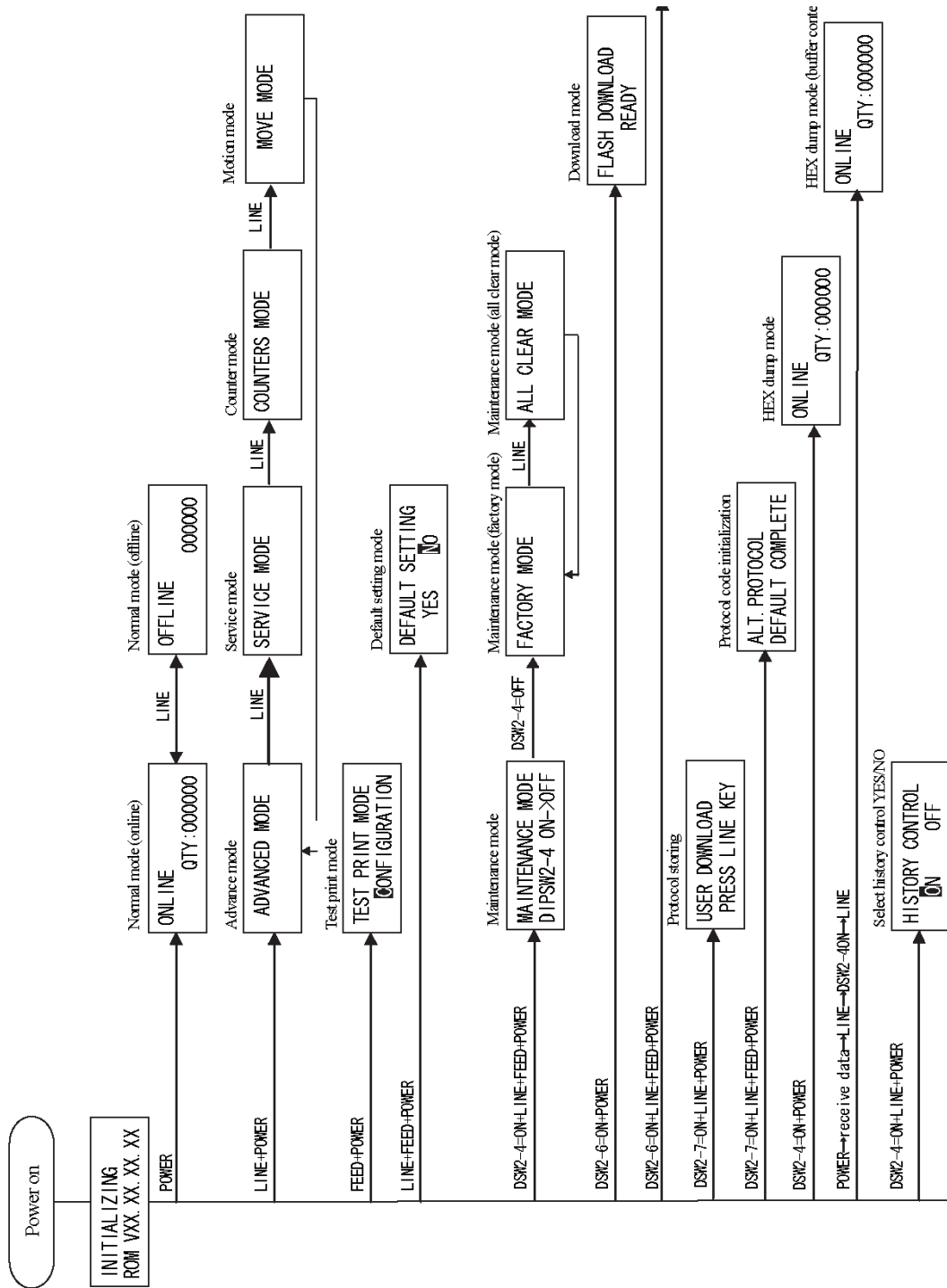

3.3 ACCESSING THE VARIOUS PRINTER MODES (CONT'D)

3.3.1 How to access special Modes and Menus after turning the power ON

Mode/Menu	DSW	Button(s) to press	Comments
Normal	NA	Press LINE to toggle ONLINE/OFFLINE	ONLINE/OFFLINE STATUS
Advanced	NA	Hold down the LINE button when turning printer ON	Each time you pressing the LINE button, you will rotate through Service Mode, Counter Mode and Motion Mode
Service	NA	Press the LINE button in Advanced Mode	Press LINE again to go to Counters Mode
Counter	NA	Press the LINE button in Service Mode	Press LINE again to go to Motion Mode
Motion	NA	Press the LINE button in Counters Mode	Press LINE again to return to Advanced Mode
Test Print	NA	Press the FEED button when turning the printer ON	Create test prints in this mode
Default Settings	NA	Press the LINE and FEED buttons when turning the printer ON	Resets various user settings to factory default values
Maintenance	DSW2-4	If DIPSW2-4 is ON, printer goes into Maintenance Mode. Set DSW2-4 off to access Factory Mode	Press the LINE button to reach the ALL CLEAR menu to restore all settings to factory default values
Flash Download Ready	DSW2-6	Set DSW2-6 ON when turning the printer ON	Readies the printer to receive replacement firmware code without boot codes
Boot Downloader	DSW2-6	Set DSW2-6 ON and hold down the FEED and LINE buttons when turning the printer ON	Readies the printer to receive replacement firmware code with boot codes
User Download	DSW2-7	Set DSW2-7 ON and hold down the LINE button when turning the printer ON	Readies the printer to receive user graphics and fonts, etc
Protocol Code Select	DSW2-7	Set DSW2-7 ON and hold down the FEED and LINE buttons when turning the printer ON	This method initializes the protocol code to the default value
Hex Dump	DSW2-4	Set DSW2-4 ON when turning the printer ON	Generates a hex dump of memory
Hex Dump (buffer dump)	NA	Turn the printer ON. Send data to it, press the LINE button to go offline, then DSW2-4 On. Press Line again.	Generates successive hex dumps of incoming data
History Control	DSW2-4	Set DSW2-4 ON and hold down the LINE button when turning the printer ON	Turns the Hysteresis (or History) Control feature of the print head On/Off

3.3.2 OVERVIEW OF LCD MENU OPTIONS IN VARIOUS MODES

The chart below provides an overview of the LCD menus and options presented to the user in the different modes.

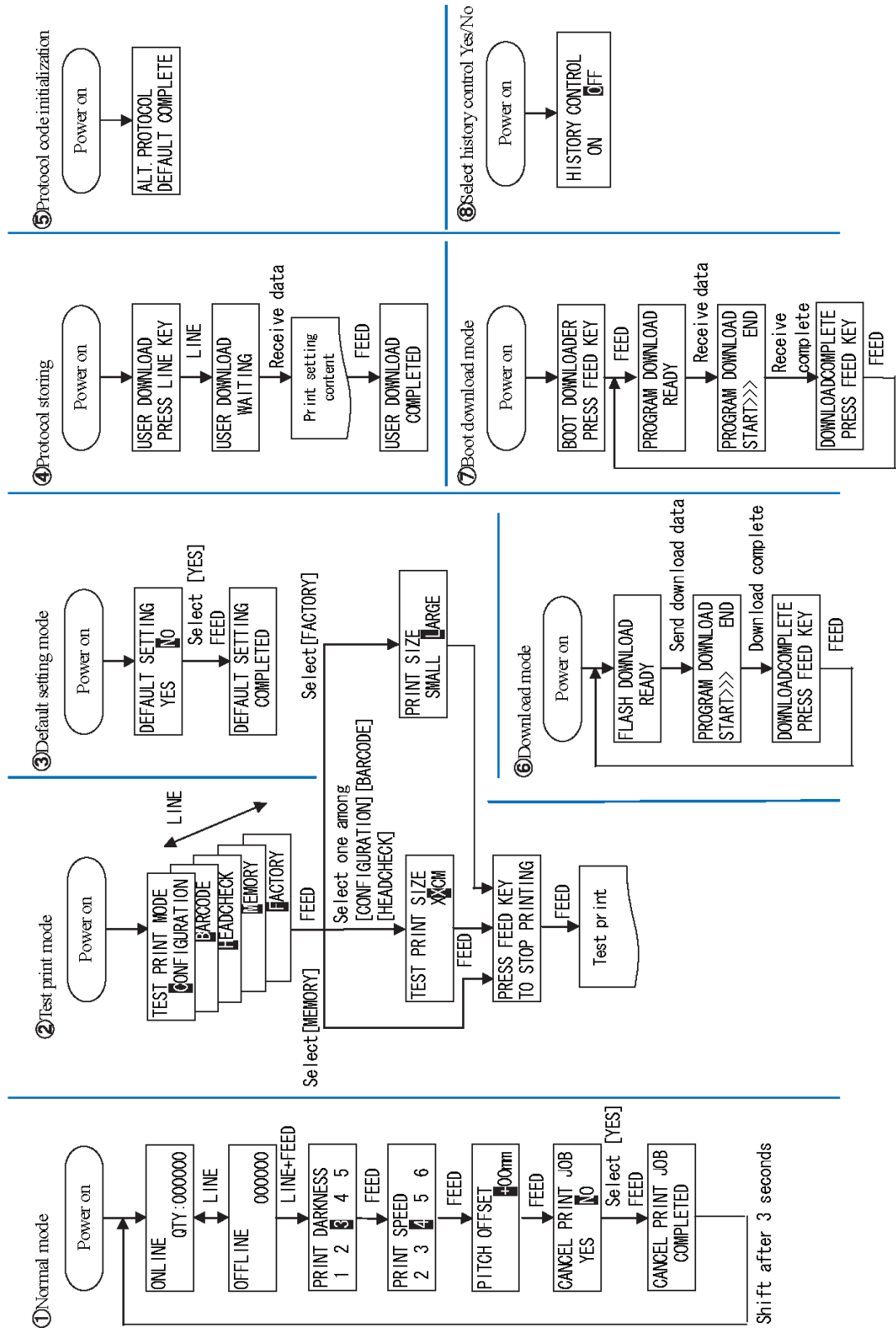

3.3.2 OVERVIEW OF LCD MENU OPTIONS IN VARIOUS MODES (CONT'D)

The chart below provides an overview of the LCD menus and options presented to the user in the different modes.

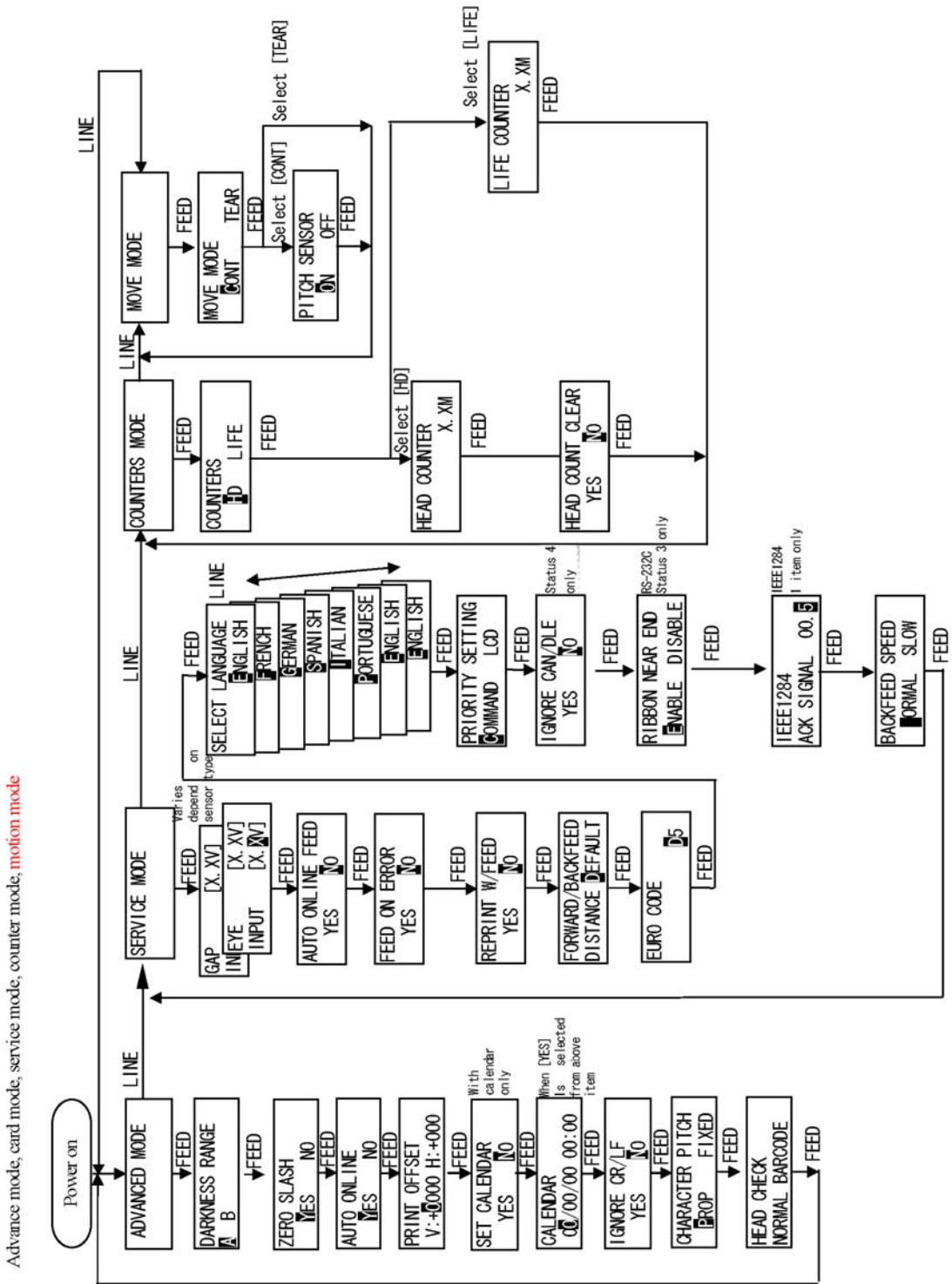

3.3.2 OVERVIEW OF LCD MENU OPTIONS IN VARIOUS MODES (CONT'D)

The chart below provides an overview of the LCD menus and options presented to the user in the different modes.

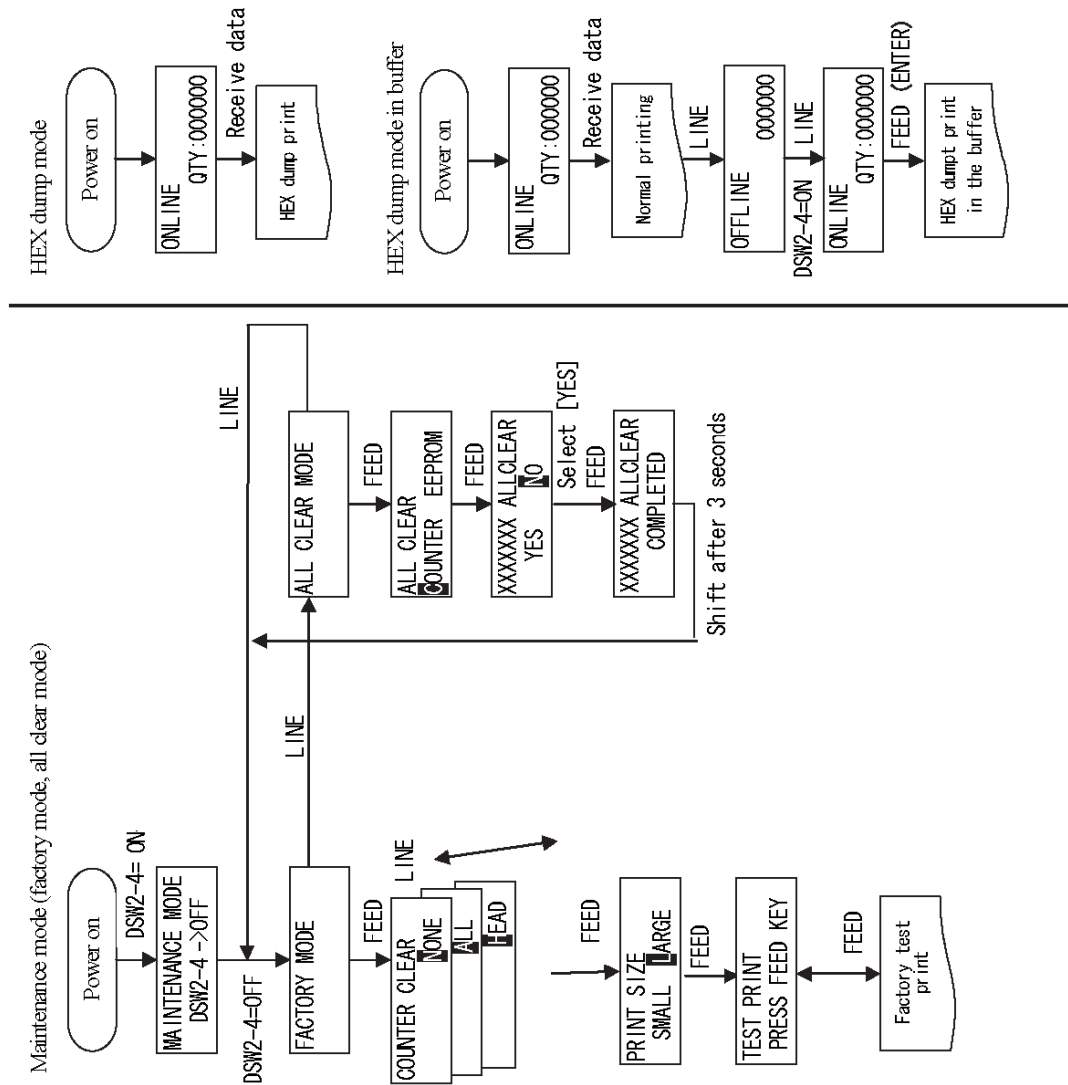

3.4 NORMAL MODES

3.4.1 Online

Pressing the **LINE** button causes the printer to go ONLINE or OFFLINE alternately.



When the printer is ONLINE, the following activities will be possible:

- The printer is ready to receive print data from the computer or other connected devices
- The printer is ready to start printing
- The QTY counter is reduced in value with every printed label
- Pressing the FEED button normally has no effect in ONLINE Mode. However, if the REPRINT W/FEED option is selected in Service Mode, then this button causes the printer to reprint the most recent printed label

Pause screen

If a Print Stop Request command DLE (10H) is received in ONLINE mode, the printer LCD shows the PAUSE screen and the QTY value. The screen changes to ONLINE once printing resumes.

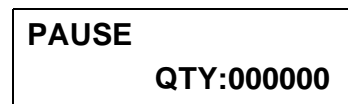

3.4.2 Offline

When the printer is ONLINE, pressing the **LINE** button once will cause the printer to go OFFLINE.

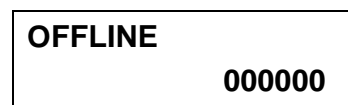

When the printer is OFFLINE, the activities for ONLINE mode are no longer possible, but the following activities will be possible:

- The printer can eject labels when you press the **FEED** button.
- Any printing job can be stopped once the printer is brought OFFLINE
- The **Print Darkness** screen if you press **LINE** and **FEED** together in this mode.

3.4.3 Print Darkness

Pressing **LINE** and **FEED** together in OFFLINE mode calls up this setting for controlling the density of print.



Press the **LINE** button repeatedly to select 1 to 5, where 1 is the lightest setting and 5 is the darkest setting. Press the **FEED** button to confirm the setting and proceed to the Print Speed screen.

3.4 NORMAL MODES (CONT'D)

3.4.4 Print Speed

Pressing **LINE** repeated cycles through the various available speeds. The slowest speed is 2ips, while the highest speed is 6ips. The default speed for the LM Basic 408e is 4ips.



Press the **FEED** button to select a print speed. The screen for Pitch Offset appears.

3.4.4 Pitch Offset

This screen lets you adjust the pitch offset by up to +/- 49mm. The default value is 0.



Press the **LINE** button to shift the cursor from left to right. When the cursor is over the "+" or "-" symbol, press the **FEED** button to cycle it between "+" and "-". The cursor then moves one step to the right.

When the cursor is over one of the numeric digits, press the **FEED** button to cycle it between "0" and "9" to form the first or second digit of the desired pitch offset value.

Finally, press the **FEED** button to proceed to the screen for **Cancel Print Job**.

3.4.5 Cancel Print Job

This screen lets you cancel the current print job and all received data for the label.



Press the **LINE** button to switch the cursor between YES and NO. When the cursor is over the desired option, press the **FEED** button to confirm the setting.

If you selected YES, the print job is cancelled, and the following screen appears for about three seconds:



The screen then goes back to ONLINE status.

3.5 ADVANCED MODE

3.5.1 Advanced

Holding down the **LINE** button when turning the printer ON causes the printer to go into the Advanced Mode.

ADVANCED MODE

In the following screens of Advanced Mode, you can control the Darkness Range, Zero Slash symbol, Auto Online option, Print Offset, Calendar settings, Ignore CR/LF function, Character Pitch and Head Check feature. Press the **FEED** button to begin.

3.5.2 Darkness Range

Use this setting to choose between two sets of minimum and maximum achievable darkness levels for printing. Darkness range A is suitable for most types of labels. Darkness range B is higher in darkness, and can sometimes be use to compensate for light prints. The default setting is A.

DARKNESS RANGE

A **B**

Press the **LINE** button to select A or B, then press the **FEED** button for the next screen.

3.5.3 Zero Slash

This function works with XU, XS, XM, XB, XL and outline fonts. Select **YES** to print the digit Zero with a diagonal slash across it. Select **NO** to use a standard Zero. The default is **YES**.

ZERO SLASH

YES **NO**

Press the **LINE** button to select YES or NO, then press the **FEED** button for the next screen.

3.5.4 Auto Online

Selecting **YES** causes the printer to go into **ONLINE** Mode when it is turned ON. Selecting **NO** leaves the printer in **OFFLINE** Mode when it is turned ON. The default setting is **YES**.

AUTO ONLINE

YES **NO**

Press the **LINE** button to select YES or NO, then press the **FEED** button for the next screen.

3.5.5 Print Offset

This setting defines how many dots vertically and horizontally away from the origin (0,0) to begin printing at. The default value is 0 for both offsets. The valid offset range is:

PRINT OFFSET

V: +0000 H: +000

Vertical: +0 to +1424 (LM408e) or +0 to +2136 (LM412e).

Horizontal: +0 to +/- 832 (LM408e) or +0 to +/-1248 (LM412e).

Press the **FEED** button move the cursor over each adjustable value, and the **LINE** button to change it. After setting the offsets, press the **FEED** button until the following screen appears.

3.5 ADVANCED MODE (CONT'D)

3.5.6 Set Calendar

If a Calendar chip has been installed, this screen allows you to set the time and date. The default is NO.

SET CALENDAR	
<input checked="" type="checkbox"/> YES	<input type="checkbox"/> NO

Selecting YES calls up a screen for setting the Year, Month, Day, Hour and Minute respectively.

CALENDAR	
<input checked="" type="checkbox"/> 00/00/00	<input type="checkbox"/> 00:00

Press the **LINE** button to select YES or NO, and the **FEED** button to proceed. If **YES** is selected, press the **FEED** button to move the cursor over each value of the date and time. Use the **LINE** button to change each set of values. When done, press the **FEED** button until the next screen appears.

3.5.7 Ignore CR/LF

Selecting YES causes all CR/LF codes to be ignored in the incoming print data. The default is NO.

IGNORE CR/LF	
<input checked="" type="checkbox"/> YES	<input type="checkbox"/> NO

Press the **LINE** button to switch the cursor between YES and NO. When the cursor is over the desired option, press the **FEED** button to confirm the setting and proceed to the next screen.

3.5.8 Character Pitch

For the XU, XS, XM, XB, XL, outline and CG fonts, this setting determines whether each character is placed at a FIXED or PROPORTIONAL distance away from the next character.

CHARACTER PITCH	
<input checked="" type="checkbox"/> PROP	<input type="checkbox"/> FIXED

The default is PROPORTIONAL pitch, meaning that the distance between characters is not fixed, but adjusted automatically for neater printing.

Press the **LINE** button to switch the cursor between PROP or FIXED. Press the **FEED** button to confirm the setting and proceed to the next screen.

3.5.8 Head Check

When DSW2-3 is ON, the head check function can apply to all NORMAL printed data, or to BARCODE only.

HEAD CHECK	
<input checked="" type="checkbox"/> NORMAL	<input type="checkbox"/> BARCODE

The default is NORMAL, where the head checking applies for barcodes as well as graphics and text.

Press the **LINE** button to switch the cursor between NORMAL or BARCODE. Press the **FEED** button to confirm the setting and return to the first ADVANCED Mode next screen.

3.6 SERVICE MODE

3.6.1 Service

In this mode, pressing the **LINE** button brings you to the COUNTERS mode screen. Otherwise, press **FEED** to proceed to adjust service mode settings.

SERVICE MODE

In the following screens of Service Mode, you can control the Slice Level, Auto Line Feed, Feed On Error, Reprint W/Feed, Forward/Backfeed Amount, Forward/Backfeed Distance, Euro Code symbol, Menu Language, Command/LCD Priority. Ignore CAN/DLE, Ribbon Near End detection, IEEE1284 ACK width, and Backfeed Speed.

3.6.2 Slice Level

For the Gap and I-Mark sensors, this setting lets you set the slice level to control the gap detection for label stopping. The upper value shows the current sensor detection level, and the lower value is for adjustment. If the value is set at 0.0V, the printer will automatically set the slice level.

GAP	[X. XV]
INPUT	[X. XV]

Use the **LINE** button to set the slice level from 0.0 to 3.2V. Use the **FEED** button to select the input value and proceed to the next setting screen.

EYE	[X. XV]
INPUT	[X. XV]

3.6.3 Auto Line Feed

Use this function to determine whether the printer automatically feeds a label upon being turned ON/going online. Select YES for an auto line feed; otherwise select NO. The default setting is NO.

AUTO ONLINE FEED
YES NO

Press the **LINE** button to select YES or NO, then press the **FEED** button for the next screen.

3.6.4 Feed On Error

Use this function to determine whether the printer automatically feeds a label upon resuming from an error condition. Select YES for an auto line feed; otherwise select NO. The default setting is NO.

FEED ON ERROR
YES NO

Press the **LINE** button to select YES or NO, then press the **FEED** button for the next screen.

3.6.5 Reprint W/Feed

Determines if the **FEED** button generates a reprint of the most recently printed label during ONLINE mode. Default is NO.

REPRINT W/FEED
YES NO

Press the **LINE** button to select YES or NO, then press the **FEED** button for the next screen.

3.6 SERVICE MODE (CONT'D)

3.6.6 Forward/Backfeed Amount

This setting allows customization of the label feed/backfeed distance instead of the default setting.

FORWARD/BACKFEED
DISTANCE **DEFAULT**

If DISTANCE is selected, the next menu appears, for setting of the amount of label feed/backfeed. Use the **LINE** button to select DISTANCE or DEFAULT, and if applicable, to set the amount of label feed/backfeed.

FORWARD/BACKFEED
DISTANCE **001MM**

Press the **FEED** button for the next screen.

3.6.7 Euro Code

This setting defines the code to represent the Euro mark. The default is D5H.

EURO CODE
D5

Use the **FEED** button to move the cursor to the set the value of the code. Use the **LINE** button to set the value under the cursor. When the value has been set, the following screen appears.

3.6.8 Select Language

This screen lets you choose the language used for all commands and messages on the LCD. Use the **LINE** button from ENGLISH (default), FRENCH, GERMAN, SPANISH, ITALIAN, PORTUGUESE and two repeated options for ENGLISH. Press the **FEED** button to confirm the setting and proceed to the next screen.

SELECT LANGUAGE
ENGLISH

3.6.9 Command or LCD Priority

Use this setting to determine whether SBPL commands are accepted and allowed priority over settings of Print Darkness, Print Speed, Print Offset via LCD. The default setting is COMMAND, where SBPL commands take precedence over settings made via the LCD menus.

PRIORITY SETTING
COMMAND LCD

Press the **LINE** button to select Command or LCD. Press the **FEED** button for the next screen.

3.6.10 Ignore CAN/DLE

Determines whether the CANCEL and DATA LINK ESCAPE codes are processed or ignored. Select YES to ignore, and NO to process the codes. The default is NO.

IGNORE CAN/DLE
YES NO

Press the **LINE** button to select YES or NO, then press the **FEED** button for the next screen.

3.6 SERVICE MODE (CONT'D)

3.6.11 Ribbon Near End On/Off

This screen lets you enable or disable the early detection and warning of the ribbon supply reaching an end. The default value is **ENABLE**

RIBBON NEAR END
ENABLE DISABLE

Use the **LINE** button to select **ENABLE** or **DISABLE**, then press the **FEED** button for the next screen.

3.6.12 IEEE1284 ACK Signal

If the printer is connected using an IEEE1284 cable, this setting appears. It lets you define the ACK width of the interface from 0.5 to 10.0 microseconds. The default is 0.5 microseconds.

IEEE1284
ACK SIGNAL 00.5

Press the **LINE** button to rotate the value from 0.5 to 10.0 and back to 0.5 microseconds in steps of 0.1 microsecond. When you are done, press the **FEED** button to confirm the value and proceed to the final setting of Service Mode.

3.6.13 Backfeed Speed

The backfeed speed can be left at **NORMAL** rates or **SLOW**ed down to reduce stress on the media. The default is **NORMAL**.

BACKFEED SPEED
NORMAL SLOW

Use the **LINE** button to select either **NORMAL** or **SLOW** and then press the **FEED** button to confirm the setting and return to the main Service Mode screen.

3.7 COUNTERS MODE

3.7.1 Counters

In this mode, pressing the **LINE** button brings you to the Motion Mode settings. Otherwise, press **FEED** to proceed to adjust the behavior of the built-in counters.

COUNTERS MODE

In the following screens of Counters Mode, you can choose between the Head Counter or Life Counter, see the Head Counter value, clear the Head Counter, and see the Life Counter value.

3.7.2 Counter Select

In this screen you can select between the Head counter (HD) or Life counter (LIFE).

Use the **LINE** button to select either counter, then press the **FEED** button to confirm the setting and proceed to the next setting screen.

COUNTERS

HD LIFE

3.7.3 Show Head Counter

This screen shows the distance of label printed by the print head.

Press the **FEED** button for the next screen.

HEAD COUNTER

X. XM

3.7.4 Clear Head Counter

In this screen, you can reset the Head Counter value to 0 by selecting YES. Otherwise, select NO. The default setting is NO.

Press the **FEED** button for the next screen.

HEAD COUNT CLEAR

YES NO

3.7.5 Show Life Counter

This screen shows the distance of label generated by the printer in total.

Press the **FEED** button for the next screen.

LIFE COUNTER

X. XM

3.8 MOVE MODE

3.8.1 Movements of Labels

In this mode, pressing the **LINE** button returns you to the main Advance Mode screen. Otherwise, press **FEED** to proceed to adjust the behavior of the built-in counters.



A rectangular box containing the text "MOVE MODE" in a bold, sans-serif font.

In the following screens of Move Mode, you can control the following label motion options: Continuous or Tear Off, Pitch Sensor ON/OFF.

3.8.2 Move Mode

In this screen you can select between Continuous feeding of labels (where labels are not detached from each other), or Tear Off operation (where each label must be torn off before printing resumes). The default is CONT.



A rectangular box containing the text "MOVE MODE" at the top and "CONT TEAR" below it. The "C" in "CONT" is highlighted with a dark square.

Use the **LINE** button to select either CONT or TEAR. If CONT is selected, the next screen (Pitch Sensor ON/OFF) appears. Otherwise, the printer returns to the main Move Mode menu. After selecting the Move Mode, press the **FEED** button to confirm the setting and proceed to the next screen.

3.8.3 Pitch Sensor

This screen lets you enable or disable the pitch sensor.

Use the **LINE** button to select either ON or OFF. The default setting is ON. Then press the **FEED** button to return to the main Advance Mode screen.



A rectangular box containing the text "PITCH SENSOR" at the top and "ON OFF" below it. The "O" in "ON" is highlighted with a dark square.

3.9 TEST PRINT MODE

3.9.1 Select Test Print

In this mode, you can choose from five types of test prints.

The five settings in this mode are as follows:

TEST PRINT MODE
CONFIGURATION

CONFIGURATION	The configuration settings of the printer will be printed.
BARCODE	The barcodes installed in this printer will be printed.
HEAD CHECK	The head check pattern of the selected paper size area will be printed.
MEMORY	The contents of the memory will be printed.
FACTORY	The factory test print will be performed.

Use the **LINE** button to select the test print pattern to generate, then press the **FEED** button to confirm the setting and proceed to the next screen.

3.9.2 Test Print Size

In this screen you can specify the print width for all the test print patterns except MEMORY. The default setting is the maximum horizontal size of the loaded paper.

TEST PRINT SIZE
XX CM

For the LM408e/412e, the test print paper width can be set from 4 to 10.

Use the **LINE** button to select modify the value of the print size, then press the **FEED** button to confirm the setting and proceed to the next screen.

3.9.3 Print Size

For the Factory Test Print pattern, this screen lets you define the test print paper width. The default value for the LM408e/412e is LARGE (104mm). The preset value for SMALL is 30mm.

PRINT SIZE
SMALL LARGE

Use the **LINE** button to select either SMALL or LARGE. Then press the **FEED** button to confirm the setting and proceed to the final screen.

3.9.3 Start/Stop Test Print

At this screen the test printing will have commenced. Press **FEED** to stop or restart the printing.

PRESS FEED KEY
TO STOP PRINTING

3.10 DEFAULT SETTING MODE

3.10.1 Resetting the Printer

In this mode, selecting **YES** will reset the settings in the printer to factory defaults. The default value for this screen is NO.

DEFAULT SETTING
YES NO

Use the **LINE** button to select YES or NO. If YES is selected, the next screen appears.

3.10.2 Reset Completed

The various settings listed below have been reset to factory defaults. Turn the printer OFF now.

DEFAULT SETTING
COMPLETED

Setting item	LM408e	LM412e
Normal mode		
Print darkness	3	3
Print speed	4 inch/sec	4 inch/sec
Pitch offset	+00	+00
Advance mode		
Print darkness range	-	A
Zero slash	Enable	Enable
Auto-online	Enable	Enable
Print offset	V: +0000 H: +000	V: +0000 H: +0000
Ignore CR/LF	No deletion	No deletion
Character pitch	Proportional	Proportional
Cover open sensor	Disable	Disable
Head check method	-	-
Card mode		
Card slot1	-	-
Service mode		
Sensor slice level	Auto setting	Auto setting
Default feed	Disable	Disable
Online feed	Disable	Disable
Re-print	Disable	Disable
Feed setting	Default option feed amount	Default option feed amount
External signal 9 pin output mode	-	-
Acceleration, deceleration speed curve	-	-
Euro code	D5H	D5H
Display language setting	English	English
Priority setting	Enable command	Enable command
1 byte command setting	Enable	Enable
Ribbon near end detection	Enable	Enable
IEEE1284 · ACK width	0.5µs	0.5µs
Back-feed speed	NORMAL	NORMAL
Others		
History control	Disable	Disable

3.11 PROTOCOL STORING

3.11.1 Protocol Download

In this mode, DSW2-7=OFF for standard code, and DSW2-7=ON for non-standard code. Press the **LINE** to set the printer ready to receive protocol data. The following screen appears:

**USER DOWNLOAD
PRESS LINE KEY**

**USER DOWNLOAD
WAITING**

3.11.2 Loading Completed

Proceed to send protocol data from the host PC. When the protocol code is received, the content being stored will be printed out.

Press the **FEED** button to store the protocol code. When the protocol code has been stored, the following screen appears.

**USER DOWNLOAD
COMPLETED**

3.11.3 Initialization of Protocol Code

In this screen, you can reset any non-standard protocol code to the default value.

**ALT. PROTOCOL
DEFAULT COMPLETE**

The default values are STX (7BH) • ETX (7DH) • ESC (5EH) • ENQ (40H) • NULL (7EH) • CAN (21H) • Offline (5DH) • Euro code (D5H).

3.12 MAINTENANCE MODE

3.12.1 Factory or All Clear Mode

In this mode, the status of DSW2-4 determines whether you can access the Factory mode or the All Clear Mode. Set DSW2-4=ON first. Then the printer will remain Maintenance Mode until the DSW2-4 is set to OFF.

COUNTERS MODE

In the Factory Mode settings, you can change the following: Counter Clear, Print Size for test print width, and Start/Stop test print. In All Clear settings, you can clear the Counter/EEPROM.

3.12.2 Factory Mode

In this screen you can choose to perform an All Clear for all the counters, or clear on the Head Counter.

COUNTER CLEAR
NONE

The default value is NONE. Use the **LINE** button to select NONE, ALL or HEAD as required.

COUNTER CLEAR
ALL

Press the FEED button to confirm the reset and proceed to the next screen.

COUNTER CLEAR
HEAD

3.12.3 Test-Print Width

In this screen you can choose either a SMALL or LARGE test print. The default value is LARGE.

COUNTER CLEAR
NONE

On the LM408e/412e, the value for SMALL is 40mm, and for LARGE, the value is 104mm.

Use the **LINE** button to select SMALL or LARGE, then press the **FEED** button to confirm the setting and proceed to the test print.

3.12.4 Start/Stop Test Print

This screen appears during the actual test printing.

Press the **FEED** button to stop or resume the test printing.

TEST PRINT
PRESS FEED KEY

3.12 MAINTENANCE MODE (CONT'D)

3.12.5 All Clear Mode

In All Clear settings, you can clear the Counter/EEPROM. Press the **FEED** button to proceed.

ALL CLEAR MODE

3.12.6 Counter/EEPROM clear

In this screen you can choose to clear either the Head Counter or the EEPROM. The default value is COUNTER.

ALL CLEAR
COUNTER EEPROM

Use the **LINE** button to select COUNTER or EEPROM as required.

COUNTER CLEAR
 ALL

Press the FEED button to confirm the reset and proceed to the next screen.

3.12.7 Clear Confirmation

In this screen you have to confirm whether to proceed with the clearing of the counter or EEPROM. The default value is NO.

XXXXXXX ALL CLEAR
YES NO

Use the **LINE** button to select YES or NO as required.

XXXXXXX ALL CLEAR
COMPLETED

Press the FEED button to confirm the reset and the last screen appears to confirm the clearance.

3.13 HEX DUMP MODE

3.13.1 LCD Status

In the Hex Dump Mode, when data is received, a hex dump is printed. The LCD screen then shows the quantity of labels printed, and the printer status.

ONLINE QTY: 000000

3.13.2 Hex Dump Mode in buffer

In this mode, only the buffer data is dumped. The quantity of labels printed is updated on the LCD screen.

ONLINE QTY: 000000

The procedure for such a buffer dump is as follows:

1. Make sure the printer is turned OFF.
2. Set DSW2-4 to ON, then press the **LINE** button to take the printer ONLINE.
4. Send data to the printer.
5. To return to normal mode, turn the printer OFF and set DSW2-4 to OFF.
6. Finally, turn the printer ON again to let the new mode take effect.

3.14 DOWNLOAD MODE

3.14.1 LCD Status

In the mode, the LCD shows whether the printer is ready to receive the Flash Download. At the screen shown here, proceed to send the program/font/command data from the host PC.

FLASH DOWNLOAD READY

The following screen then appears.

The “>” sign is used to show the progress of the data transfer.

XXXXXXX DOWNLOAD START>>>>>>END
--

1. “>” means downloading has started.
2. “>>” means 1Mb of data has been received and processed.
3. “>>>” means 3Mb of data has been received and processed.
4. “>>>>” means the data transfer has completed.
5. “>>>>>” means that some data is being checked.
6. “>>>>>>” means the all data is being verified.
7. “>>>>>>>” means that the data has been verified and written to memory.

Do NOT turn the printer OFF when the printer is downloading data to Flash memory.

When the entire process is complete, the following screen appears:

DOWNLOADCOMPLETE PRESS FEED KEY
--

Press the FEED button to return to the main Download Mode screen.

3.15 BOOT DOWNLOAD MODE

3.15.1 LCD Status

In the mode, the LCD shows the Boot Downloader prompt. Press the **FEED** button to prepare the printer for the data.

**BOOT DOWNLOADER
PRESS FEED KEY**

The following screen then appears. Start sending the data from the host PC.

**PROGRAM DOWNLOAD
READY**

The next screen then appears:

The “>” sign is used to show the progress of the data transfer.

**PROGRAM DOWNLOAD
START>>>>>>END**

1. “>” means downloading has started.
2. “>>” means 1Mb of data has been received and processed.
3. “>>>” means 3Mb of data has been received and processed.
4. “>>>>” means the data transfer has completed.
5. “>>>>>” means that some data is being checked.
6. “>>>>>>” means the all data is being verified.
7. “>>>>>>>” means that the data has been verified and written to memory.

Do NOT turn the printer OFF when the printer is downloading data to memory.

When the entire process is complete, the following screen appears:

**DOWNLOADCOMPLETE
PRESS FEED KEY**

Press the FEED button to return to the main Download Mode screen.

4

CLEANING AND MAINTENANCE

4.1 INTRODUCTION

This section provides information on user maintenance for the LM Basic printer. The following information is covered here:

- Cleaning the Print Head, Platen and Rollers
- Adjusting print quality
- Replacing the protective fuse
- Replacing the protective Print Head

4.2 CLEANING THE PRINT HEAD, PLATEN AND ROLLERS

The print head not only generates printouts of barcodes, but also graphics and text. To produce optimal printing, it must be kept clean in spite of the dirt and adhesive that constantly accumulates on its print surface. Furthermore, dirt can accumulated along the label path, affecting parts like sensors and guides, and reducing their performance.

Therefore, it is important to clean these important components periodically. This is done with a printer cleaning kit or cleaning sheets (for print head cleaning only), available separately from your authorized SATO dealer. When the cleaning materials run out, be sure to obtain only certified replacements from your dealer.

When to clean with a cleaning kit

- ◆ For the print head, platen roller, paper sensor, and label guide: clean after using up every other roll of paper, or each time after printing 150 m.
- ◆ For other parts: clean after finishing every six rolls of paper, or every time after printing 900 m.

When to clean with the cleaning sheet

- ◆ For the print head, clean after using every six rolls of paper, or every time after printing 900 m.

4.3 HOW TO CLEAN THE PRINTER (WITH A CLEANING SET)

If a carbon ribbon has been loaded into the printer, be sure to remove it before cleaning. Follow the instructions supplied with the cleaning set. Use the items to clean the following parts.

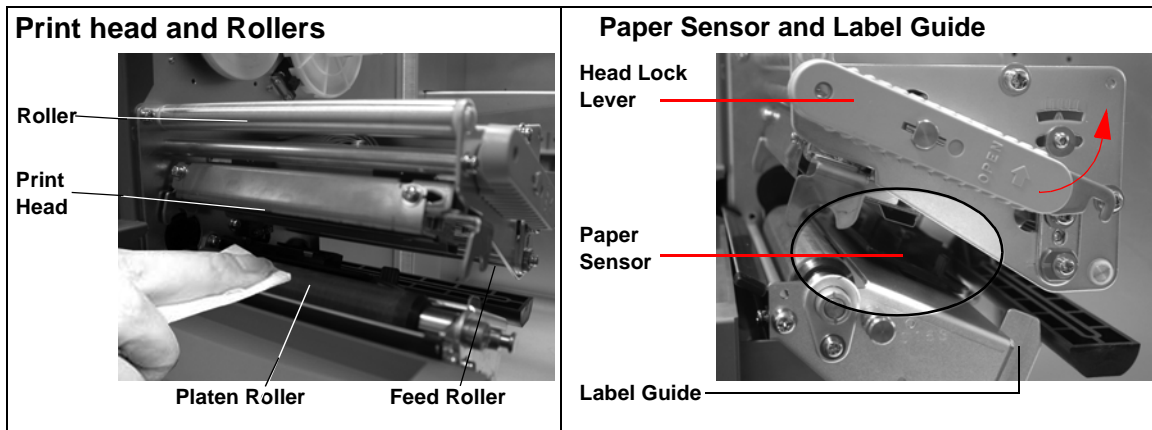

1. Lift up the main cover.
2. Unlatch the print head unit using the Head Lock Lever. The print head is now accessible.
3. Wipe off the dirt on the print head with a cleaning cloth or lint free cotton swab dabbed in an approved cleaning solution.
4. Moisten a cotton cleaning cloth with cleaning liquid, and use the cloth to wipe any dirt or accumulated adhesive off the platen roller. (See picture above).
5. Clean all the metal feed rollers that are in contact with the ribbon.

4.4 HOW TO CLEAN THE PRINTER (CLEANING SHEET)

The cleaning sheet is used for cleaning stubborn stains on the print head.

1. Lift up the front cover.
2. Unlatch the print head unit using the purple Head Lock lever. The print head is now accessible.
3. Remove the label and ribbon.
4. Put the head cleaning sheet between the print head and the platen roller. The coarse side of the cleaning sheet should face the surface of the print head elements.
5. Fasten the Head Lock lever to mount the print head.
6. Using both hands, pull the cleaning sheet outwards, toward your body. This will remove any dirt stuck to the print head. (See picture on the right)
7. When the cleaning sheet has been removed, perform steps 2 to 6 to repeat the cleaning procedure one or two more times.
8. When no more additional dirt appears on the cleaning sheet after it has been pulled out, you can stop cleaning with the sheet.
9. Unlatch the print head and use the cleaning cloth from the cleaning kit to gently remove any remaining dirt from the print head.



Caution

- Be sure to turn off the power before cleaning.
- The suggested cleaning schedule here are just guidelines. If necessary, clean as appropriate depending on the degree of contamination.
- Use a cleaning pen (for the print head only) or cotton cloth to clean the printer units.
- Use only soft, lint-free materials for cleaning. Avoid using hard objects for the cleaning process, as they will damage the components.

4.5 ADJUSTING PRINT QUALITY

Print quality can be optimized with regular cleaning and maintenance of the print head and components along the label path. Additionally, you can fine-tune print quality by adjusting print darkness and print speed settings via the front panel PRINT potentiometer and via the control panel LCD menu.

4.5.1 Adjusting Print Darkness

This adjustment allows the user to control (within a specified range) the amount of power applied to the individual print head heat elements. It is important to find a proper print darkness level based on your particular label and ribbon combination. The printed images should not be too light nor should the ink from the ribbon “bleed.” The edges of each image should be crisp and well defined.



There are two levels of print darkness setting:

1. the **hardware** setting via the PRINT potentiometer (see picture above)
2. the **software** setting (via the PRINT DARKNESS menu when you turn the printer ON while pressing the LINE and FEED buttons). The same setting can be achieved via the ESC+#E command (SBPL).

The hardware setting is the **master** setting, and affects all the software settings for print darkness. For example, the PRINT potentiometer adjustment will affect the darkness in all of the command code speed ranges, i.e. if the PRINT potentiometer is adjusted for lighter print, the darkness will be lighter in all speed ranges selected by the command code.

PRINT Potentiometer — To perform fine adjustment for print darkness, use the potentiometer labelled PRINT on the configuration panel. It provides a continuous range of adjustment, allowing you to make precise changes. Use a small cross-head screwdriver with a plastic head (not provided), turning clockwise for darker print and counterclockwise for lighter print. See **Section 3: Configuration** for instructions on performing potentiometer adjustments.

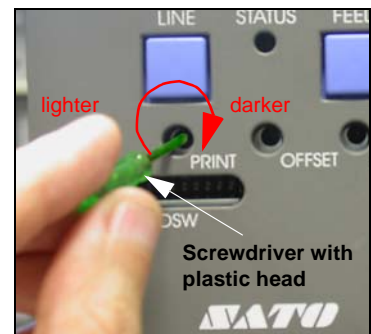

LCD Panel — The Print Darkness can also be set from the configuration panel or by sending the Print Darkness software command from a computer. The setting range is not as fine as the potentiometer adjustment: there are only five settings, from 1 (lightest) to 5 (darkest). The default setting is 3. Once the range has been selected, the Darkness Potentiometer on the front panel can be used to make finer adjustments. For instructions on setting Print Darkness, refer to **Section 3: Configuration**.

4.5 ADJUSTING PRINT QUALITY (CONT'D)

4.5.2 Adjusting Print Speed

Besides varying the print darkness level to control print quality, you can also change the rate at which labels are printed. The Print Speed adjustment affects how much time is allowed for the print head elements to produce a printout. The more time given (i.e., lower print speed) the better the print quality.

LCD Panel — Print Speed can only be set using software, via the the configuration panel LCD or by sending the Print Speed software command (ESC +CS) from a computer. There are five settings, from 02 ips (slowest) to 6 ips (fastest). The default setting is 4.



For instructions on setting Print Speed, refer to page 3-9, Operation and Configuration.

4.6 REPLACING A BLOWN FUSE

The T3 3A fuse protects the LM printer from damage. If it ever needs replacement, obtain a correct replacement fuse from your SATO dealer and follow the procedure below:

1. Turn the printer power off and remove the power cable.
2. On the back of the printer, locate the Fuse Cap directly above the AC connector.
3. Unscrew the cap and remove the defective fuse.
4. Replace with a new 250V 3A fuse.
5. Screw the cap back onto the printer and replace the power cord.



This page is intentionally left blank

5

INTERFACE SPECIFICATIONS

5.1 INTERFACE TYPES

The LM printer is supplied with a single interface of the user's choice: typically a parallel interface is used for transmitting data to and from the host. However, note that no external signal interface is available as an option for connecting the printer to other peripherals.

The following are the different types of interface boards available:

- 1) RS232C Interface Board
- 2) IEEE 1284 Interface Board
- 3) USB Interface Board (Ver. 1.1)
- 4) LAN Interface Board (10Base-T/100Base-T)
- 5) IEEE 802.11b Wireless LAN Interface Board

5.2 INTERFACE CARD DIP SWITCH SETTINGS (RS-232C)

The LM Basic super-speed serial interface card (optional) contains DIP switches for controlling communication conditions. The DIP switch functions are:

Switch No.	Function	Description	
1	Data length setting	ON: 7 Data Bits OFF: 8 Data Bits	
2	Parity bit setting	OFF — OFF: None	
3		OFF — ON: Even number ON — OFF: Odd number ON — ON: Not used	
4	Stop bit setting	ON: 2 Stop Bits OFF: 1 Stop Bit	
5	Baud rate setting	OFF — OFF: 9600 bps	
6		OFF — ON: 19200 bps ON — OFF: 38400 bps ON — ON: 57600 bps	
7	Communication Protocol setting	1-7 1-8 Compatibility mode OFF	Compatibility mode ON
8		OFF OFF: READY/BUSY OFF ON : XON/XOFF ON OFF : Driver specific protocol ON ON : Not used	READY/BUSY XON/XOFF Status 3 Status 2



Caution

Always turn the printer OFF before attaching or detaching an interface card. Otherwise, severe electrical damage may be incurred, or bodily injury may be sustained.

Note:

Check the setting seal of the serial interface card.

The correct settings may vary depending on the type and revision of the board.

Any communication settings not controlled by the DIP switches can be set in the printer's Interface Mode using the operation panel.

5.3 INTERFACE CARD DIP SWITCH SETTINGS (LAN)

The LM Series Local Area Network interface card (optional) contains DIP switches for initializing LAN configuration, LAN printing configuration, and LAN card self-diagnosis. The DIP switch functions are:

Switch No.	LM408e/412e LAN Interface Card function
1	Reserved
2	Initializes LAN card configuration information
3	Prints LAN card configuration information (configuration information such as the IP address will be printed)
4	Prints LAN card self-examination (results of LAN card examination will be printed)

5.4 INTERFACE CARD DIP SWITCH SETTINGS (WIRELESS LAN)

The LM Series Wireless Local Area Network interface card (optional) contains DIP switches for initializing LAN configuration, LAN printing configuration, LAN card self-diagnosis and wireless mode settings. The DIP switch settings must be made before installing the card into the printer. The DIP switch functions are:

Switch No.	LM408e/412e Wireless LAN Interface Card function	
1	Reserved	
2	Initializes LAN card configuration information	
3	Prints LAN card configuration information (configuration information such as the IP address will be printed)	
4	Prints LAN card self-examination (results of LAN card examination will be printed)	
5	Wireless Communication mode	OFF—OFF : 802.11 Ad hoc
6		OFF—ON : Infrastructure ON—OFF : Ad hoc ON—ON : Unused

5.5 EXTERNAL SIGNAL INTERFACE

Unlike the more advanced SATO printers such as the CL4XXe series, the LM printer cannot be fitted with an EXT Signal Interface card for sending printer information status to any device or LAN. If you need this functionality in future, please consider purchasing a SATO printer featuring the EXT signal interface as an option.

5.6 SERIAL INTERFACE SPECIFICATIONS (RS-232C)

The serial interface of this printer conforms to the RS-232C standard. There are two types of receive modes: 1. Single Job Buffer 2. Multi Job Buffer These can be set using the dip switches.

Basic Specifications

Standard Interface	On the interface board																																																																																
Dip Switch 1) Character configuration 2) Transmission speed 3) Protocol	<table border="1"> <tr> <td rowspan="2">1-1</td> <td rowspan="2">Data bit length</td> <td colspan="2">OFF</td> <td colspan="2">8 bits</td> </tr> <tr> <td colspan="2">ON</td> <td colspan="2">7 bits</td> </tr> <tr> <td rowspan="4">1-2 1-3</td> <td rowspan="4">Parity bit (2-3)</td> <td>DSW1-2</td> <td>DSW1-3</td> <td colspan="2"></td> </tr> <tr> <td>OFF</td> <td>OFF</td> <td colspan="2">NONE</td> </tr> <tr> <td>OFF</td> <td>ON</td> <td colspan="2">EVEN</td> </tr> <tr> <td>ON</td> <td>OFF</td> <td colspan="2">ODD</td> </tr> <tr> <td rowspan="2">1-4</td> <td rowspan="2">Stop bit</td> <td colspan="2">OFF</td> <td colspan="2">1 bit</td> </tr> <tr> <td colspan="2">ON</td> <td colspan="2">2 bits</td> </tr> <tr> <td rowspan="4">1-5 1-6</td> <td rowspan="4">Baud rate (5-6)</td> <td>DSW1-5</td> <td>DSW1-6</td> <td>DIPSW2-8 OFF*</td> <td>DIPSW2-8 ON</td> </tr> <tr> <td>OFF</td> <td>OFF</td> <td>9600bps</td> <td>9600bps</td> </tr> <tr> <td>OFF</td> <td>ON</td> <td>19200bps</td> <td>19200bps</td> </tr> <tr> <td>ON</td> <td>OFF</td> <td>38400bps</td> <td>4800bps</td> </tr> <tr> <td rowspan="4">1-7 1-8</td> <td rowspan="4">Protocol (7-8)</td> <td>DSW1-7</td> <td>DSW1-8</td> <td>DIPSW2-8 OFF*</td> <td>DIPSW2-8 ON</td> </tr> <tr> <td>OFF</td> <td>OFF</td> <td>Ready/Busy</td> <td>Ready/Busy</td> </tr> <tr> <td>OFF</td> <td>ON</td> <td>X-on-Xoff</td> <td>X-on-Xoff</td> </tr> <tr> <td>ON</td> <td>OFF</td> <td>Status 3 echo</td> <td>Status 3 echo</td> </tr> <tr> <td></td> <td></td> <td>ON</td> <td>ON</td> <td>Driver protocol</td> <td>Status2 echo</td> </tr> </table> <p>Note: The switch between Single Job Buffer and Multi Job Buffer can be specified by software. *Valid if Compatible Mode is disabled in the printer via the Service Mode menu.</p>	1-1	Data bit length	OFF		8 bits		ON		7 bits		1-2 1-3	Parity bit (2-3)	DSW1-2	DSW1-3			OFF	OFF	NONE		OFF	ON	EVEN		ON	OFF	ODD		1-4	Stop bit	OFF		1 bit		ON		2 bits		1-5 1-6	Baud rate (5-6)	DSW1-5	DSW1-6	DIPSW2-8 OFF*	DIPSW2-8 ON	OFF	OFF	9600bps	9600bps	OFF	ON	19200bps	19200bps	ON	OFF	38400bps	4800bps	1-7 1-8	Protocol (7-8)	DSW1-7	DSW1-8	DIPSW2-8 OFF*	DIPSW2-8 ON	OFF	OFF	Ready/Busy	Ready/Busy	OFF	ON	X-on-Xoff	X-on-Xoff	ON	OFF	Status 3 echo	Status 3 echo			ON	ON	Driver protocol	Status2 echo
1-1	Data bit length			OFF		8 bits																																																																											
		ON		7 bits																																																																													
1-2 1-3	Parity bit (2-3)	DSW1-2	DSW1-3																																																																														
		OFF	OFF	NONE																																																																													
		OFF	ON	EVEN																																																																													
		ON	OFF	ODD																																																																													
1-4	Stop bit	OFF		1 bit																																																																													
		ON		2 bits																																																																													
1-5 1-6	Baud rate (5-6)	DSW1-5	DSW1-6	DIPSW2-8 OFF*	DIPSW2-8 ON																																																																												
		OFF	OFF	9600bps	9600bps																																																																												
		OFF	ON	19200bps	19200bps																																																																												
		ON	OFF	38400bps	4800bps																																																																												
1-7 1-8	Protocol (7-8)	DSW1-7	DSW1-8	DIPSW2-8 OFF*	DIPSW2-8 ON																																																																												
		OFF	OFF	Ready/Busy	Ready/Busy																																																																												
		OFF	ON	X-on-Xoff	X-on-Xoff																																																																												
		ON	OFF	Status 3 echo	Status 3 echo																																																																												
		ON	ON	Driver protocol	Status2 echo																																																																												
Synchronization mode	Asynchronous																																																																																
Maximum Receivable Buffer capacity	<p>2.95Mbyte</p>																																																																																
Code used	ASCII(7 bit) Graphics(8 bit)																																																																																
Connectors	Printer side DB-25S (Female) Cable side DB-25P (Male) Cable length 5 meters or less																																																																																
Transmission format	<table border="1"> <tr> <td>Start</td> <td>b1</td> <td>b2</td> <td>b3</td> <td>b4</td> <td>b5</td> <td>b6</td> <td>b7</td> <td>b8</td> <td>Stop</td> </tr> </table> <p>Note b8 is not applicable when using 7 bits.</p>	Start	b1	b2	b3	b4	b5	b6	b7	b8	Stop																																																																						
Start	b1	b2	b3	b4	b5	b6	b7	b8	Stop																																																																								
Signal level	High level: +5 ~ +12V Low level: -5 ~ -12V																																																																																

5.7 READY/BUSY

Ready / Busy is the hardware flow control method for the serial interface on the printer. Data received cannot be guaranteed, when print data (ESC+"A"~ESC+"Z") is sent from the host, under the following conditions:

- 1) When the printer is Offline
- 2) When an error has occurred in the printer

Pin Assignments

1) DB-25 P			DB-25 P	
Printer			Host	
FG	1	————	1	FG
SD	2	————→	3	RD
RD	3	←————	2	SD
RS	4	————→	5	CS
CS	5	←————	4	RS
DR	6	←————	20	ER
SG	7	————	7	SG
ER	20	————→	6	DR

2) DB-25P			DB-9P	
Printer			Host	
FG	1	————		
SD	2	————→	2	RD
RD	3	←————	3	SD
RS	4	————→	8	CS
CS	5	←————	7	RS
DR	6	←————	4	ER
SG	7	————	5	SG
ER	20	————→	6	DR

When using Windows Hardware Control:

3) DB-25 P			DB-25 P	
Printer			Host	
FG	1	————	1	FG
SD	2	————→	3	RD
RD	3	←————	2	SD
CS	5	←————	20	ER
RS	4	————→	6	DR
DR	6	←————	4	RS
SG	7	————	7	SG
ER	20	————	5	CG

4) DB-25P			DB-9P	
Printer			Host	
FG	1	————		
SD	2	————→	2	RD
RD	3	←————	3	SD
CS	4	←————	4	ER
RS	5	————→	6	DR
DR	6	←————	7	RS
SG	7	————	5	SG
ER	20	————→	6	CS

Interface Signals

Pin no.	Signal Type	Direction	Contents
1	FG	-	Frame Ground
2	SD	Output	Send Data
3	RD	Input	Receive Data
4	RS	Output	Request to Send
5	CS	Input	Clear to Send
6	DR	Input	Data Set Ready
7	SG	-	Signal Ground
20	ER	Output	Eqpt Ready (also used for handling error status)

5.8 SINGLE JOB BUFFER

Timing Chart — Normal Processing

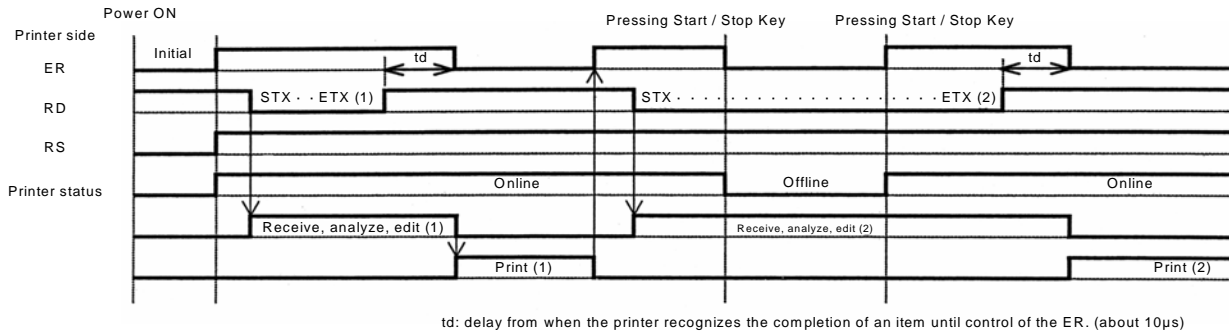

Timing Chart — Error Processing

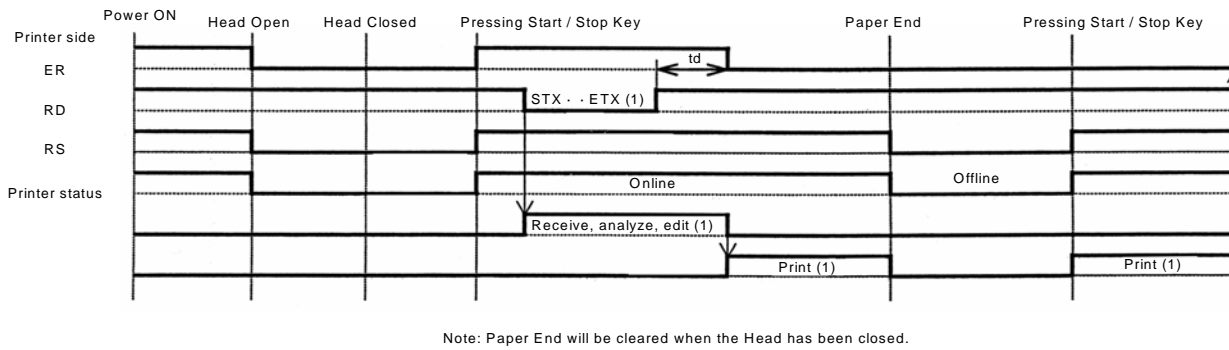

5.9 MULTI JOB BUFFER

Timing Chart — Normal Processing

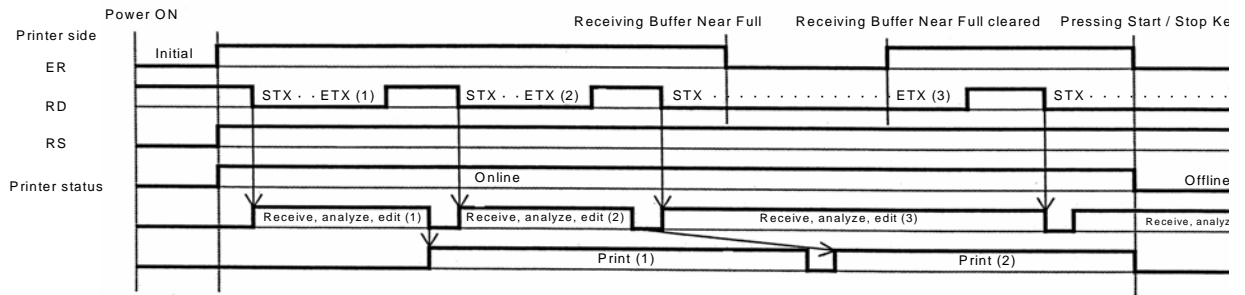

Note: Data will be normally be received Online, during Multi-reception.

Timing Chart — Error Processing

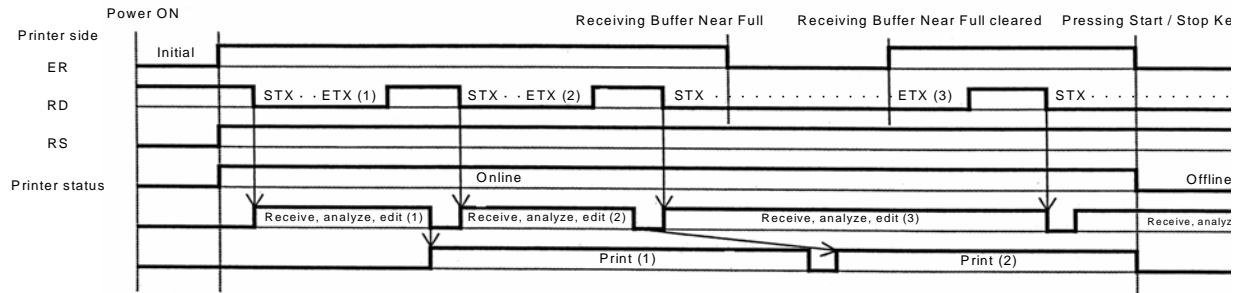

Note: Data will be normally be received Online, during Multi-reception.

5.10 X-ON/X-OFF

This transmission protocol informs the host if the printer can receive data or not, by sending the "XON" (Hex 11H) or "XOFF" (Hex 13H) code.

Data received cannot be guaranteed, when print data (ESC+"A"~ESC+"Z") is sent from the host, under the following conditions:

- 1) When the printer is Offline
- 2) When an error has occurred in the printer

Pin Assignments

1) DB-25 P			DB-25 P	
Printer			Host	
FG	1	————	1	FG
SD	2	————▶	3	RD
RD	3	◀————	2	SD
RS	4		5	CS
CS	5		4	RS
DR	6		20	ER
SG	7	————	7	SG
ER	20		8	DR

2) DB-9P			DB-9P	
Printer			Host	
FG	1			
SD	2	————▶	2	RD
RD	3	◀————	3	SD
RS	4		8	CS
CS	5		7	RS
DR	6		4	ER
SG	7	————	5	SG
ER	20		6	AR

Caution!

In the connections, it may be necessary to loop (usually kept "High") CS and RS on the host side depending on the type of host. Therefore, make sure to re-check the host before use.

Input/Output Signals

Pin no.	Signal Type	Direction	Contents
1	FG	-	Frame Ground
2	SD	Output	Send Data
3	RD	Input	Receive Data
7	SG	-	Signal Ground

5.11 SINGLE JOB BUFFER

Timing Chart — Normal Processing

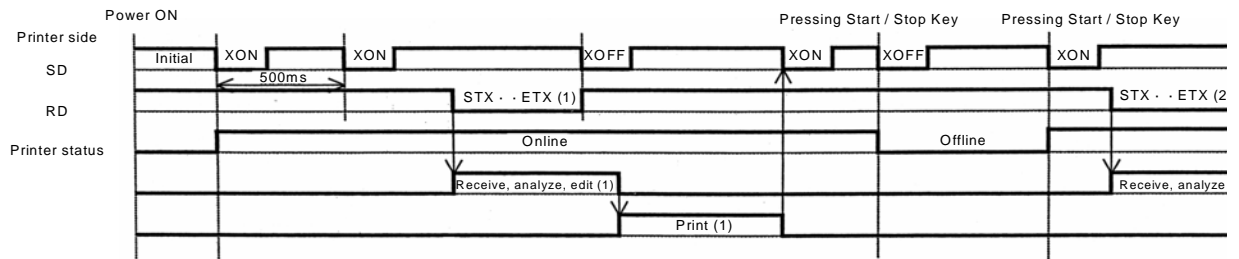

Note: This protocol will execute an "XON" polling at an interval of 500ms, from the moment the power is turned on until the receipt

Timing Chart — Error Processing

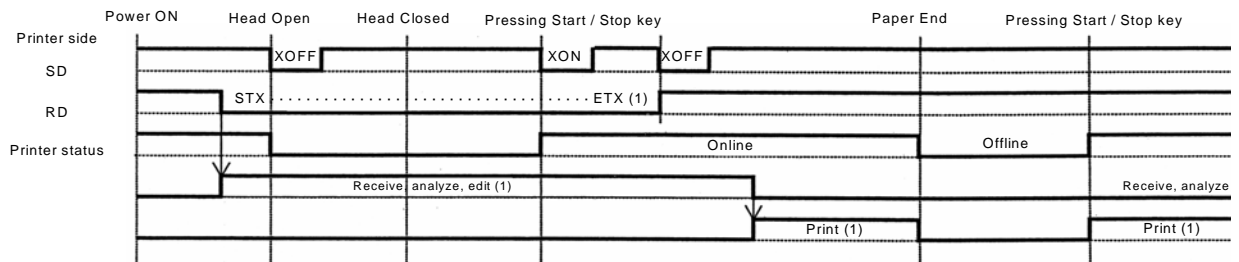

Note: Paper End will be cleared when the Head has been closed.

5.12 MULTI JOB BUFFER

Timing Chart — Normal Processing

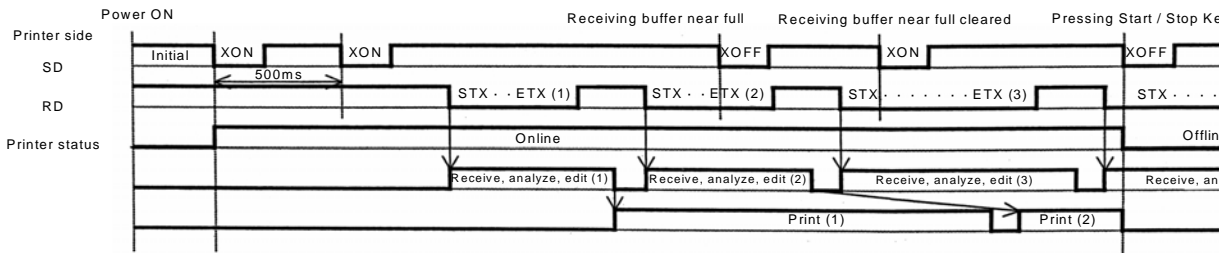

Note: This protocol will execute an "XON" polling at an interval of 500ms, from the moment the power is turned on until the receipt

Timing Chart — Error Processing

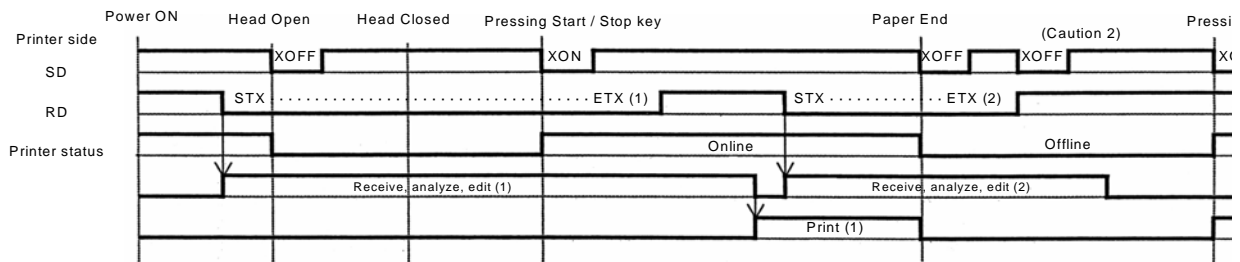

Note: Paper End will be cleared when the Head has been closed.
 Note 2: An "XOFF" transmission will be executed when receiving data during the occurrence of an error







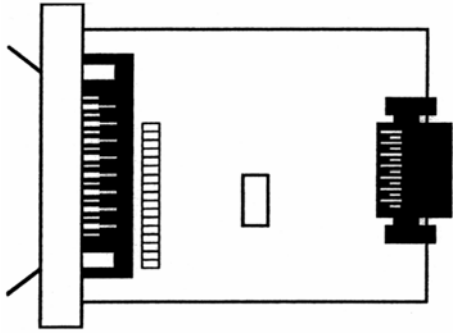

5.13 IEEE 1284 INTERFACE

The IEEE 1284 Interface on the printer complies with IEEE1284 standards.

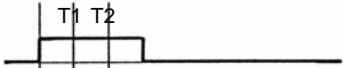
The ECP mode is recommended for LPT1 port settings.

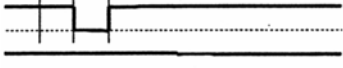
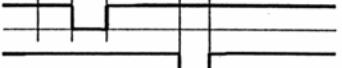
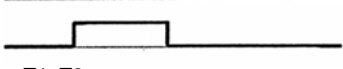
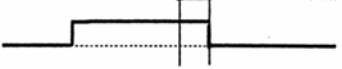
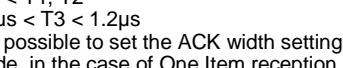
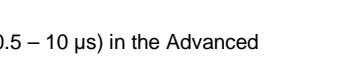
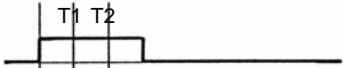
Make sure to change the LPT1 port settings through the BIOS settings.

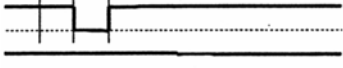
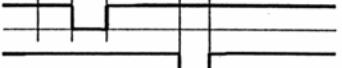
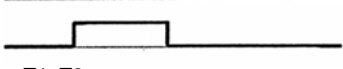
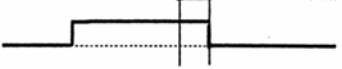
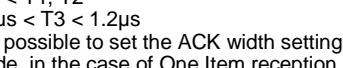
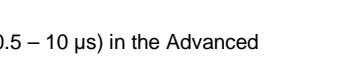
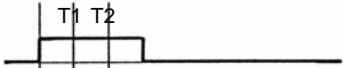
Basic Specifications

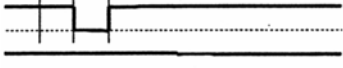
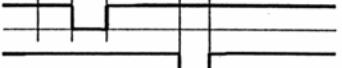
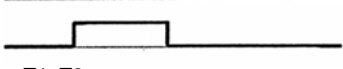
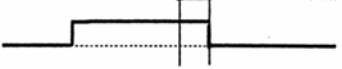
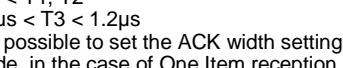
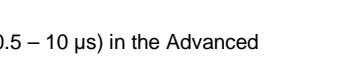
Interface board																
Connector	Printer Amphenol (DDK) 57 to 40360 (Equivalent) Cable Amphenol (DDK) 57 to 30360 (Equivalent) Cable length Under 3 meters															
Signal level	High level : + 2.4 to + 5.0 V Low level : - 0.0 to - 0.4 V															
Communication settings	One item or Multi communication can be selected using DSW2-5. <table border="1" data-bbox="639 1126 1161 1238" style="margin-left: auto; margin-right: auto;"> <thead> <tr> <th>DIPSW2-5</th> <th>Set Range</th> </tr> </thead> <tbody> <tr> <td>ON</td> <td>Multi-reception</td> </tr> <tr> <td>OFF</td> <td>One Item</td> </tr> </tbody> </table>	DIPSW2-5	Set Range	ON	Multi-reception	OFF	One Item									
DIPSW2-5	Set Range															
ON	Multi-reception															
OFF	One Item															
Maximum Receive buffer capacity	2.95Mbyte <div style="margin-left: 40px;"> 0Mbyte 2.95Mbyte Near full  Remain. 0.95Mbyte Near full clear  Remain. 1.95Mbyte </div>															
Timing chart	<table style="width: 100%; border-collapse: collapse;"> <thead> <tr> <th style="width: 50%;"></th> <th style="width: 50%; text-align: center;">ECP mode</th> <th style="width: 50%; text-align: center;">Centronics compatible mode</th> </tr> </thead> <tbody> <tr> <td style="vertical-align: top;">DATA</td> <td style="text-align: center;"></td> <td style="text-align: center;"></td> </tr> <tr> <td style="vertical-align: top;">STROBE</td> <td style="text-align: center;"></td> <td style="text-align: center;"></td> </tr> <tr> <td style="vertical-align: top;">ACK</td> <td style="text-align: center;"></td> <td style="text-align: center;"></td> </tr> <tr> <td style="vertical-align: top;">BUSY</td> <td style="text-align: center;"></td> <td style="text-align: center;"></td> </tr> </tbody> </table> <p style="margin-left: 40px;"> * $1\mu s < T1, T2$ * $0.6\mu s < T3 < 1.2\mu s$ * It is possible to set the ACK width settings (0.5 – 10 μs) in the Advanced mode, in the case of One Item reception. </p>		ECP mode	Centronics compatible mode	DATA			STROBE			ACK			BUSY		
	ECP mode	Centronics compatible mode														
DATA																
STROBE																
ACK																
BUSY																

5.13 IEEE 1284 INTERFACE (CONT'D)

Pin Assignment

Make sure to use a IEEE1284 compliant cable

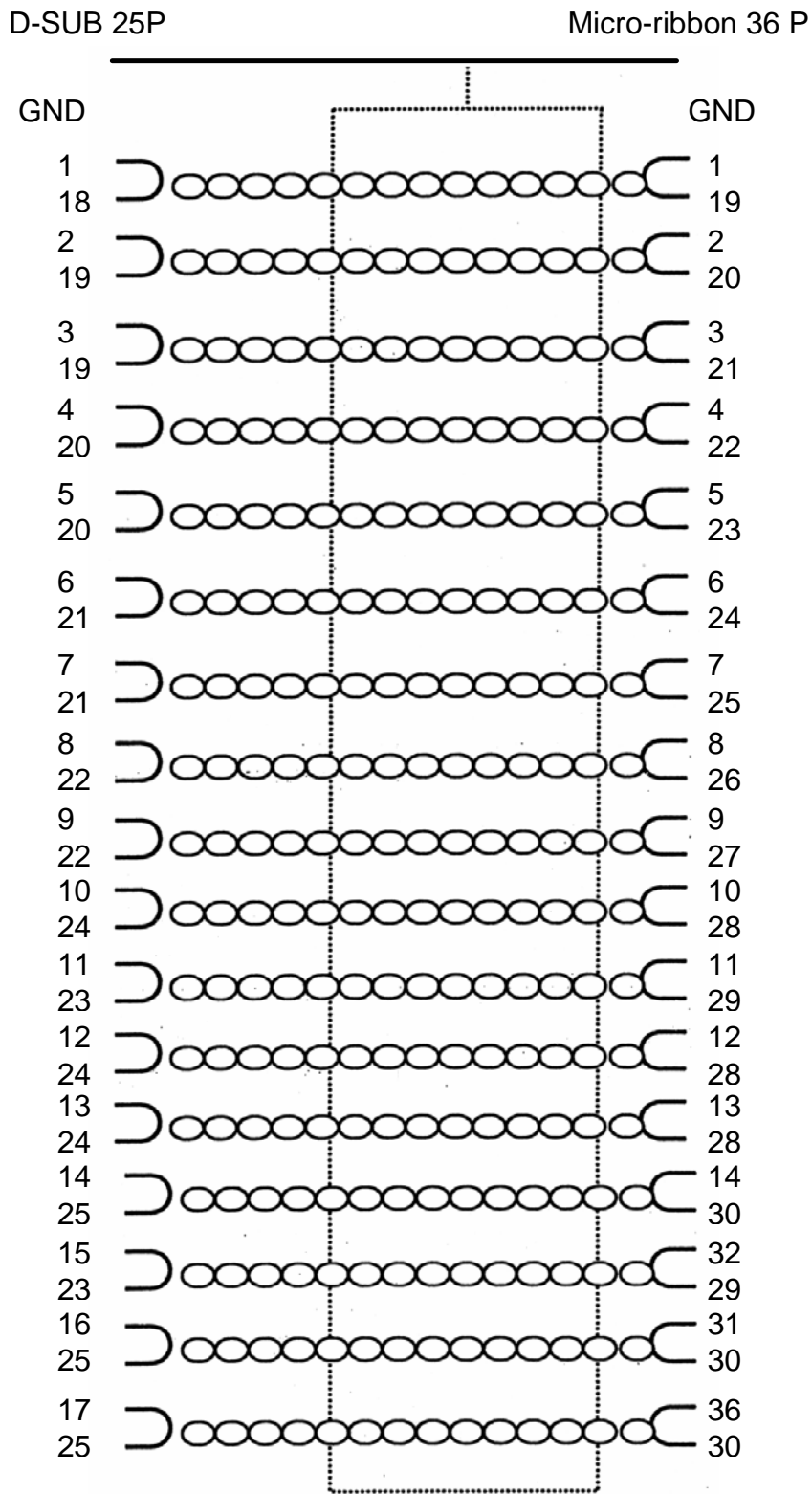

5.13 IEEE 1284 INTERFACE (CONT'D)

Pin Assignment

With Centronics standards, each signal pin placement is as follows:

However, the IEEE 1284-B type connector is compliant when connecting the IEEE1284 standard.

Pin no.	Signal Type	Content	Pin no.	Signal Type	Content
1	HOST CLK	Input	19	SIGNAL GROUND	
2	DATA 1	Input	20	SIGNAL GROUND	
3	DATA 2	Input	21	SIGNAL GROUND	
4	DATA 3	Input	22	SIGNAL GROUND	
5	DATA 4	Input	23	SIGNAL GROUND	
6	DATA 5	Input	24	SIGNAL GROUND	
7	DATA 6	Input	25	SIGNAL GROUND	
8	DATA 7	Input	26	SIGNAL GROUND	
9	DATA 8	Input	27	SIGNAL GROUND	
10	PERIPH CLK	Output	28	SIGNAL GROUND	
11	PERIPH ACK	Output	29	SIGNAL GROUND	
12	nACK REVERSE	Output	30	SIGNAL GROUND	
13	XFLAG	Output	31	NREVERSE REQUEST	Input
14	HOST ACK	Input	32	nPERIPH REQUEST	Output
15			33		
16	LOGIC GND		34		
17	CHASSIS GND		35		
18	PERIPHERAL LOGIC HIGH	Input	36	1284ACTIVE	Input

5.13 INTERFACE SIGNALS

With Centronics standards, the content of each signal type is as follows. However, each signal line used with IEEE1284 standards is compliant with IEEE1284 standards.

Pin no.	Signal Type	Direction	Contents
1	HOST CLK	Input	A low active pulse is necessary in synchronized signals for scanning Data 1 to Data 8.
2 to 9	DATA 1 to DATA 8	Input	When entering 8 bit parallel Data, Data 1 is the LSB (least significant bit) and Data 8 is the MSB (most significant bit)
10	PERIPH CLK	Output	This is the LOW active pulse signal that indicates the completion of received data scanning.
11	PERIPH ACK	Output	HIGH active signal which indicates that the printer cannot receive data.
12	nACK REVERSE	Output	HIGH active signal which indicates that the media has run out.
13	XFLAG	Output	HIGH active signal which indicates that data can be received.
14	HOST ACK	Input	Signal for when using the IEEE1284 standard.
17	CHASSIS GND		Connects to the Frame Ground
18	PERIPHERAL LOGIC HIGH	Output	The +5V voltage on the printer side.
19 to 30	SIGNAL GROUND		Connects to the ground for each signal
31	nREVERSE REQUEST	Input	LOW active signal that requests printer initialization.
32	nPERIPH REQUEST	Output	LOW active pulse signal that indicates a printer error.
36	1284ACTIVE	Input	Signal for when using the IEEE1284 standard.

5.14 SINGLE JOB BUFFER

Timing Chart — Normal Processing

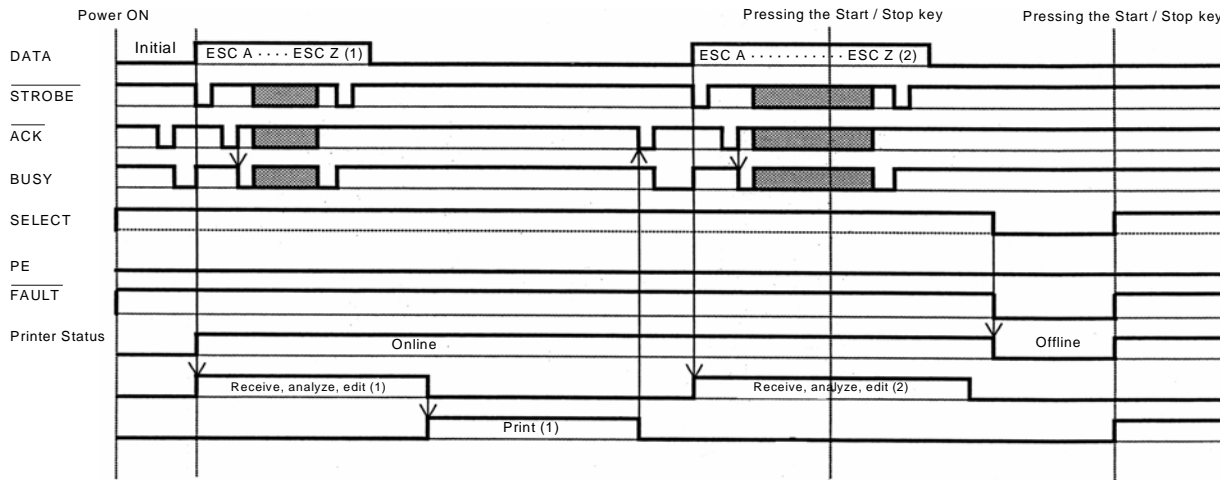

5.14 SINGLE JOB BUFFER (CONT'D)

Timing Chart — Procedure during Paper End

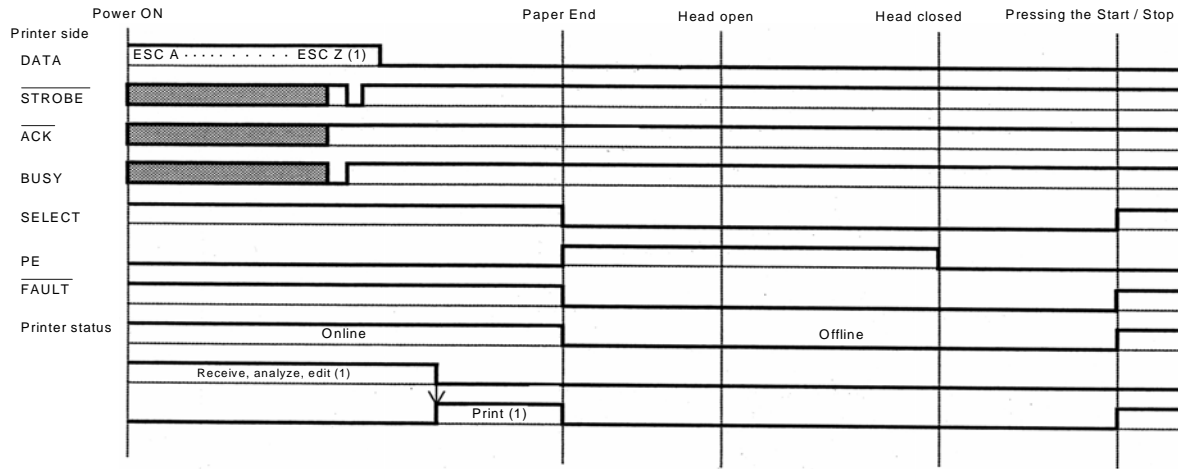

Note: Paper End is cleared by closing the Head.

5.15 MULTI JOB BUFFER

Timing Chart — Normal Process

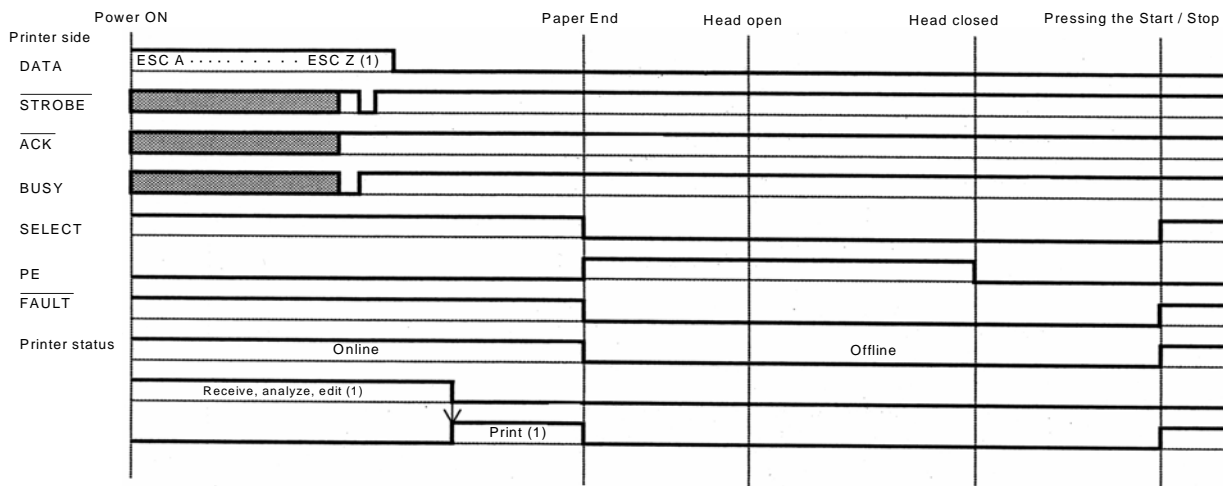

Note: Paper End is cleared by closing the Head.

5.15 MULTI JOB BUFFER (CONT'D)

Timing Chart — Procedure during Paper End

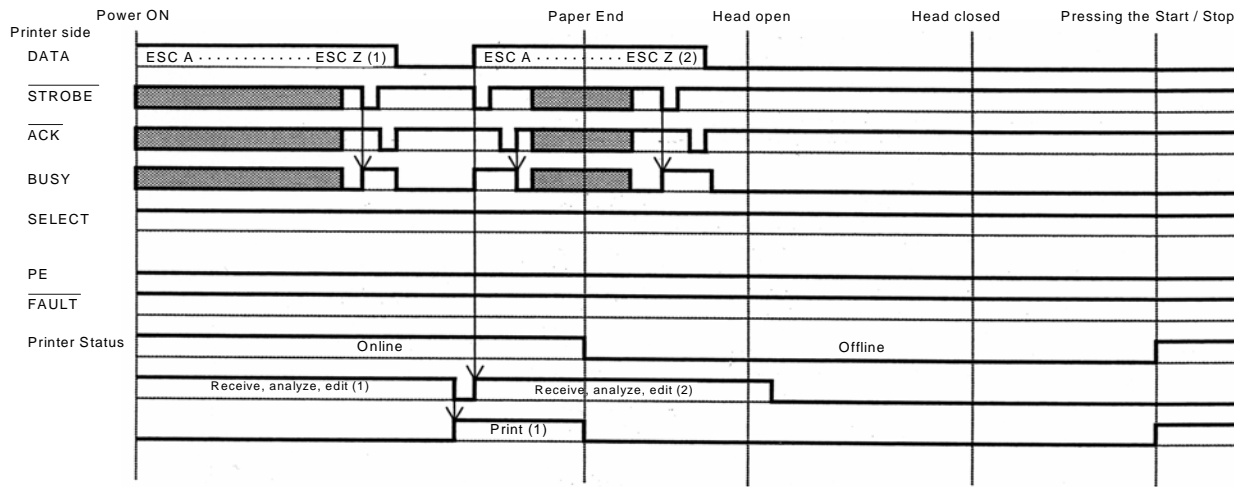

Note: Paper End is cleared by closing the Head

This page is intentionally left blank

6

TROUBLESHOOTING

If you are unable to produce printouts on the LM Series printer, use this section to make sure the basics have been checked, before deciding you are unable to proceed any further. The section is divided into seven parts:

- Initial Checklist
- Checklist for the RS232C Serial Interface
- Understanding ON LINE, RIBBON, LABEL indicators
- Understanding the LCD error messages
- Understanding the LCD warning messages
- General Troubleshooting Guide

6.1 INITIAL CHECKLIST

1. Is the printer powered up and ON LINE?
2. Is the ERROR light on the front panel OFF? If this light is ON, it may mean the print head assembly is open or another error condition is present.
3. Is the Print Head Assembly (as well as other related assembly that needs to be secured), in the latched position?

Observations

6.2 USING THE RS232C (SERIAL) INTERFACE

1. Is the RS232C Serial cable connected securely to your serial port on the PC and to the RS232C connector on the printer? (The standard SATO cable for RS-232 uses a 9 pin-female to a 25-pin male connector)
2. Is the cable defective? At the very least, you should be using a "Null Modem Cable," which crosses pins in a specific manner. This should enable your printer to print. But we recommend that you eventually use a cable built to specifications as described in **Section 5: Interface Specifications**
3. Check for obvious errors in the data stream. Remember that all print jobs for serial data must be framed by an **STX** and **ETX**. Again, see the **Section 5: Interface Specifications** if necessary.
4. If after sending your job to the printer, the LCD indicates a "framing error" message, you may have a configuration problem. There may be some inconsistencies with the Baud Rate, Parity, Data Bits, or Stop Bits in relation to your host computer. If you are confused as to what the printer's current RS232 settings are, you may choose the SATO defaults (all DIP switches in the OFF position) to achieve 9600 baud, no parity, 8 data bits, and 1 stop bit.

Observations

6.3 UNDERSTANDING THE LCD ERROR MESSAGES

When an error occurs, or when the printer needs to alert the user of something important, the message on the LCD screen will contain the necessary information. Additionally, the Status LED may light up or blink in combination with the LCD message. There is no built-in buzzer in the LM 408e/412e to provide audible warnings. On error, turn the printer OFF and ON again to verify the error..

Status LED	Message on LCD	Error	Cause	Solution
On	MACHINE ERROR	Machine Error	Defective main board	Contact qualified Service Technician
On	EEPROM ERROR	EEPROM Read/Write operation failure	EEPROM is faulty, improperly installed	Contact qualified Service Technician
On	PARITY ERROR	RS232 Parity Error	Problem with cable or interface configuration	<ul style="list-style-type: none"> • Correct the interface settings • Adjust the I/F cable
On	OVERRUN ERROR	RS232 Overrun Error	Problem with cable or interface configuration	<ul style="list-style-type: none"> • Correct the interface settings • Adjust the I/F cable
On	FRAMING ERROR	RS232 Framing Error	Problem with cable or interface configuration	Correct the interface settings or adjust the cable
On	BUFFER OVER	Buffer Overflow	Buffer capacity exceeded, or wrong interface configuration	Correct the host program and interface protocol
Blinks	HEAD OPEN	Head Open	Head Lock Lever not latched, or micro-switch faulty	Latch the print head with Head Lock Lever
Blinks	PAPER END	Label End	Paper end or improper installation. Print head open or micro switch faulty	Latch and unlatch the Head Lock Lever to secure print head
Blinks	RIBBON END	Ribbon End	Ribbon end or improper installation. Sensors need adjustment	<ul style="list-style-type: none"> • Correct the ribbon loading. • Clean and adjust the sensors.
On	SENSOR ERROR	Sensor	Wrong sensor selected. Or misaligned sensor. Paper meandering	<ul style="list-style-type: none"> • Choose correct sensor and adjust position. • Clean ribbon path
On	HEAD ERROR	Head	Replace print head	Faulty print head
Off	HEAD MISMATCH	Head	Incompatible or faulty print head	Reinstall compatible print head
On (off for I/F card error)	DOWNLOAD ERROR I/F NOT SUPPORT DATA ERROR WRITE ERROR XXXXX ERROR	Data	<ul style="list-style-type: none"> • Error in memory R/W or download • Or interface/cable error. • Faulty memory area or incorrect program parameters. 	<ul style="list-style-type: none"> • Check program. • Adjust interface board and cable. • Check onboard memory.

6.4 TROUBLESHOOTING GUIDE

Symptom: The display remains blank when the power switch is pressed.

No.	What to check	Remedy
1	Has the power cable been inserted into the power outlet securely?	Insert the power cable securely into the outlet.
2	Is the power cable damaged?	Inspect the power cable for signs of damage. If possible, try using another printer power cable. Purchase a new power cable specifically designed for this printer, from the sales outlet or dealer where you bought the printer from. Never use any other power cable but the power cable specifically designed for this printer.
3	Is electricity coming to the power outlet feeding the printer?	Connect another electrical appliance to the power outlet to check for power. If there is a problem with the main power, check if electricity is coming to the building. Also check if power failure has occurred.
4	Has the power fuse of the building blown, or has the circuit breaker been tripped?	Replace the power fuse and reset the circuit breaker.

 **Caution**

Do not operate the power switch or handle the power cable with a wet hand. You may suffer electric shocks as a result.

Symptom: Paper is fed but not printed

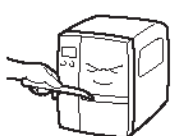
No.	What to check	Remedy
1	Is the printer head dirty, or is there any label stuck to the print head?	If the print head is dirty, wipe off the dirt with the supplied cleaning set. If a label is stuck to the print head, take it away. * Do not use metallic object to remove it (the print head may be damaged). If glue of the label is stuck to the print head, wipe it off with the supplied cleaning set. 
2	Are you using genuine SATO paper and carbon ribbons for the LM Basic?	Be sure to use genuine paper and carbon ribbon specifically designed for the printer.
3	Is the paper sensor dirty?	If the paper sensor is dirty, wipe off the dirt with the supplied cleaning set. See Section 4: Cleaning and Maintenance.
4	Is the carbon ribbon wound correctly?	If the knob of the ribbon-winding unit is not set to its original position, remove the carbon ribbon already wound, and return the knob to its original position.
5	Is the data/signal sent from the computer correct?	Turn on the power switch again. If the message still appears, check the software on the computer or the configuration for connections.

 **Caution**

Disconnect the power cable before cleaning the printer.

6.4 TROUBLESHOOTING GUIDE (CONT'D)

Symptom: Low quality print

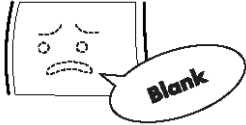
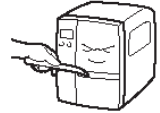
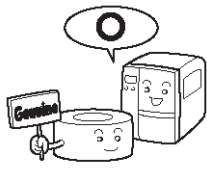
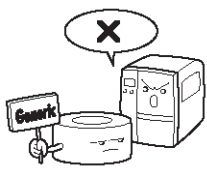
No.	What to check	Remedy
1	Are the paper and carbon ribbon set correctly?	Check if the paper and carbon ribbon are securely fixed. Also, lower the head-open lever of the print head unit, and check if the paper and carbon ribbon are in the normal position. 
2	Are the paper and carbon ribbon set correctly?	Check the paper and carbon ribbon. Set the print density again.
3	Is the platen roller dirty?	If the platen roller is dirty, wipe off the dirt with the supplied cleaning set.
4	Is the print head dirty, or is a label on the head?	If the print head is dirty, wipe off the dirt with the attached cleaning set. If a label is on the head, take it away.  <p>* Do not use a metallic object to remove it (the print head may be damaged). If glue of the label is stuck to the print head, wipe it off with the supplied cleaning set.</p> <p>See Section 4: Cleaning and Maintenance.</p>
5	Are you using stained paper?	Use clean paper.
6	Are you using genuine paper and carbon ribbon specifically designed for the printer? 	Be sure to use genuine paper and carbon ribbon specifically designed for the printer. 

Caution

Pull out the power cable before cleaning the printer.

6.4 TROUBLESHOOTING GUIDE (CONT'D)

Symptom: Print position is misaligned

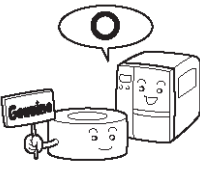
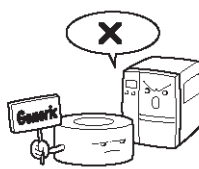
No.	What to check	Remedy
1	Are the paper and carbon ribbon set correctly?	Fix the paper and carbon ribbon securely. Also, release the print head unit, then set the paper and carbon ribbon to the normal position again. Finally, latch the print head back in place.
2	Is the platen roller dirty?	If the platen roller is dirty, wipe off the dirt with the supplied cleaning set.
3	Is the paper/carbon ribbon you are using deformed?	If the edges of the paper/carbon ribbon are deformed, the paper cannot be fed normally. Use new paper/carbon ribbon which are not deformed.
4	<p>Are you using genuine SATO paper and carbon ribbons specifically designed for the printer?</p> 	<p>Be sure to use genuine paper and carbon ribbon specifically designed for the printer. Generic supplies may cost less, but can result in poor printing quality or shortened equipment life, leading to voiding of warranty and/or higher operating costs in the long run.</p> 
5	Is the paper sensor dirty?	If the paper sensor is dirty, wipe off the dirt with the supplied cleaning set. See Section 4: Cleaning and Maintenance .
6	Is the data/signal sent from the computer correct?	Turn on the power switch again. If the error message still appears, check the software on the computer or the configuration of the connections.
7	Are the pitch correction (variable potentiometer) or base point correction (User Mode setting) settings correct?	Set the pitch correction (variable potentiometer) or base point correction (User Mode setting) again.

 **Caution**

Pull out the power cable before cleaning the printer.

7

OPTIONAL ACCESSORIES

7.1 INTRODUCTION

This section contains details of the optional accessories available for the LM printer:

- Interface boards
- Calendar IC

7.2 AVAILABLE INTERFACE BOARDS

Interface boards enable the printer to exchange data with computers, computer networks and related input/output devices. By installing a different interface board, you can adapt the LM printer to fit in a wide range of related equipment and usage scenarios.

At the time of purchase, the LM printer includes ONE interface board of your choice, from the following interface boards available:

- ▣ Serial interface board (RS-232C)
- ▣ IEEE 1284 Parallel interface board
- ▣ High Speed RS-232C
- ▣ USB 1.1 interface board
- ▣ 10BaseT/100Base-TX LAN interface board
- ▣ Wireless LAN IEEE802.11b interface board



Caution

Before installing or removing interface boards, be sure to turn off the printer first. Discharge static electricity from your body before touching any of the electronic parts. Failure to observe these precautions can result in severe damage to the components.

7.3 OPTIONAL ACCESSORIES: INTERFACE BOARDS

7.3.1 RS-232C board

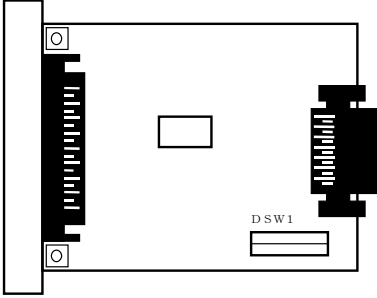
<p>Interface board</p>	
<p>Connector</p>	<p>Printer DB-25S (equivalent) (male) Cable DB-25P (equivalent) (female) Cable length shorter than 5m</p>
<p>Signal level</p>	<p>High level + 5 ~ + 12V Low level - 5 ~ - 12V</p>

7.3.2 High speed RS-232C board

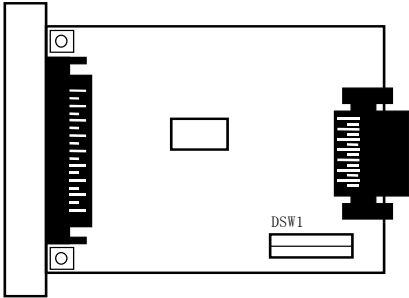
<p>Interface board</p>	
<p>Connector</p>	<p>Printer DB-25S (equivalent) (male) Cable DB-25P (equivalent) (female) Cable length shorter than 5m</p>
<p>Signal level</p>	<p>High level + 5 ~ + 12V Low level - 5 ~ - 12V</p>

7.3 OPTIONAL ACCESSORIES

7.3.3 IEEE-1284 board

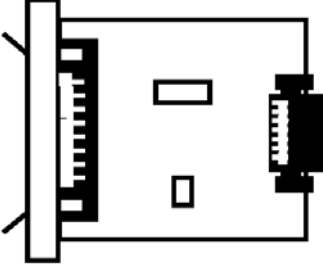
Interface board	
Connector	Printer Anphenol (DDK) 57~40360 (equivalent) Cable Anphenol (DDK) 57~30360 (equivalent) Cable length: shorter than 1.5m
Signal level	High level + 2.v ~ + 5V Low leve + 0.0 ~ - 0.4V

7.3.4 USB board

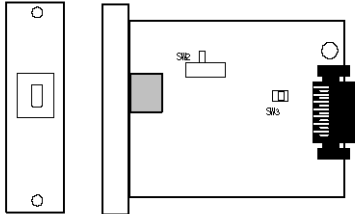
Interface board	
Connector	Connector TYPE"B" Cable length shorter than 5m
Transmission Speed	Full Speed 12Mbps, USB 1.1

7.3 OPTIONAL ACCESSORIES

7.3.5 LAN board

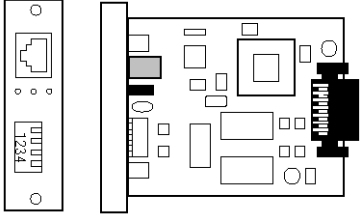
<p>Interface board</p>	
<p>Connector</p>	<p>Cable type for 10BASE-T, 100BASE-TX Cable length shorter than 100m</p>

7.4 OPTIONAL ACCESSORIES: OTHERS

7.4.1 Calendar IC

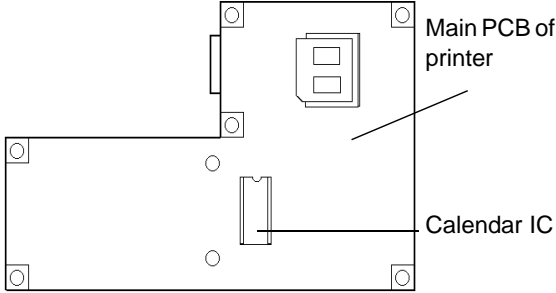
<p>Interface board</p>	 <p>Main PCB of printer</p> <p>Calendar IC</p>
<p>Connector</p>	<p>NA</p>
<p>Technical details</p>	<p>Incorporates a real-time clock for providing time and date information for label printing and other timing-related functions. Made by Dallas semi-conductor</p> <p>Warranty: 10 years (no power supply)</p> <p>Year calculation: Auto calculation of Leap years</p> <p>Lunar equation: 25 degrees Celsius, ±1 minute</p>

For more information on any of the accessories available for the LM Basic printer, please contact an authorized SATO dealer near you.

Free Manuals Download Website

<http://myh66.com>

<http://usermanuals.us>

<http://www.somanuals.com>

<http://www.4manuals.cc>

<http://www.manual-lib.com>

<http://www.404manual.com>

<http://www.luxmanual.com>

<http://aubethermostatmanual.com>

Golf course search by state

<http://golfingnear.com>

Email search by domain

<http://emailbydomain.com>

Auto manuals search

<http://auto.somanuals.com>

TV manuals search

<http://tv.somanuals.com>