



Quick Guide

For printer model:

CG4 Series



CG408DT
CG412DT
Direct Thermal Type



CG408TT
CG412TT
Thermal Transfer Type

PN: 9001222A

Read this Quick Guide before using this product.
Keep this document available for future reference.

SATO America, Inc.

10350A Nations Ford Road
Charlotte, NC 28273

Main Phone: (704) 644.1650
Technical Support: (704) 644.1660
Technical Support Fax: (704) 644.1661
E-Mail: satosales@satoamerica.com
techsupport@satoamerica.com
www.satoamerica.com

© Copyright 2010 SATO America, Inc.
All rights reserved.

Reproduction in any manner of all or part of this document is prohibited.

The content of this document may be changed without prior notice.

Great care has been taken in the preparation of this document. If any problems, mistakes, or omissions are found, please contact your SATO reseller or technical support center.

FCC Statement



The printer complies with the requirements in Part 15 of FCC Rules for a Class B Computing Device. Operating the printer in a residential area may cause unacceptable interference to radio and TV reception. If the interference is unacceptable, you can reposition the equipment, which may improve reception.

Safety Precautions

Please read the following information carefully before installing and using the printer.

Pictographic Symbols

This instruction manual and the printer labels use a variety of pictographic symbols to facilitate safe and correct use of the printer and to prevent injury to others and property damage. The symbols and meanings for them are given below. Be sure to understand these symbols well before reading the main text.

 Warning	Ignoring the instructions marked by this symbol and erroneously operating the printer could result in death or serious injury.
 Caution	Ignoring the instructions marked by this symbol and erroneously operating the printer could result in injury or property damage.

Example Pictographs





The  pictograph means "Caution is required." A specific warning symbol is contained inside this pictograph (The symbol at left is for electric shock).















The  pictograph means "Should not be done." What is specifically prohibited is contained in or near the pictograph (The symbol at left means "Disassembly prohibited").



The  pictograph means "Must be done." What is specifically to be done is contained in the pictograph (The symbol at left means "Unplug the power cord from the outlet").

 Warning		
<p>Do not set on an unstable area</p> <ul style="list-style-type: none"> Do not set on an unstable area, such as a wobbly table or slanted area or an area subject to strong vibration. If the printer falls off or topples over, it could injure someone. <p>Do not place containers full of water or other liquid on the printer</p> <ul style="list-style-type: none"> Do not place flower vases, cups, or other containers holding liquids, such as water or chemicals, or small metal objects near the printer. If they are spilled and get inside the printer, immediately turn off the power switch, unplug the power cord from the outlet, and contact your SATO reseller or technical support center. Using the printer in this condition could cause a fire or electric shock. <p>Do not put objects inside the printer</p> <ul style="list-style-type: none"> Do not insert or drop in metal or burnable objects inside the printer's openings (cable outlets, etc.). If foreign objects do get inside the printer, immediately turn off the power switch, unplug the power cord from the outlet, and contact your SATO reseller or technical support center. Using the printer in this condition could cause a fire or electric shock. <p>Use only the specified voltage</p> <ul style="list-style-type: none"> Do not use other than the specified voltage. Doing so could result in fire or electric shock. 	<p>Always ground the connections</p> <ul style="list-style-type: none"> Always connect the printer's ground wire to a ground. Not grounding the ground wire could result in electric shock. <p>Handling of the power cord</p> <ul style="list-style-type: none"> Do not damage, break, or modify the power cord. Also, do not place heavy objects on the power cord, heat it, or pull it because doing so could damage the power cord and cause a fire or electric shock. If the power cord becomes damaged (core is exposed, wires broken, etc.), contact your SATO reseller or technical support center. Using the power cord in this condition could cause a fire or electric shock. Do not modify, excessively bend, twist, or pull the power cord. Using the power cord in such a condition could cause a fire or electric shock. <p>When the printer has been dropped or broken</p> <ul style="list-style-type: none"> If the printer is dropped or broken, immediately turn off the power switch, unplug the power cord from the outlet, and contact your SATO reseller or technical support center. Using the printer in this condition could cause a fire or electric shock. 	<p>Do not use the printer when something is abnormal about it</p> <ul style="list-style-type: none"> Continuing to use the printer in the event something is abnormal about it, such as smoke or unusual smells coming from it, could result in fire or electric shock. Immediately turn off the power switch, unplug the power cord from the outlet, and contact your SATO reseller or technical support center for repairs. It is dangerous for the customer to try to repair it, so absolutely do not attempt repairs on your own. <p>Do not disassemble the printer</p> <ul style="list-style-type: none"> Do not disassemble or modify the printer. Doing so could result in fire or electric shock. Ask your SATO reseller or technical support center to conduct internal inspections, adjustments, and repairs. <p>Regarding the cutter</p> <ul style="list-style-type: none"> Do not touch the cutter with your hands or do not put something into the cutter. Doing so could result in an injury. <p>Using the head cleaning fluid</p> <ul style="list-style-type: none"> Use of flame or heat around the head cleaning fluid is prohibited. Absolutely do not heat it or subject it to flames. Keep the fluid out of reach of children to prevent them from accidentally drinking it. If the fluid is drunk, immediately consult with a physician.

 Caution		
<p>Do not place in areas with high humidity</p>  <ul style="list-style-type: none"> Do not place the printer in areas with high humidity or where condensation forms. If condensation forms, immediately turn off the power switch and do not use the printer until it dries. Using the printer while condensation is on it could result in electric shock. <p>Carrying the Printer</p>  <ul style="list-style-type: none"> When moving the printer, always unplug the power cord from the outlet and check to make sure all external wires are disconnected before moving it. Moving the printer with the wires still connected could damage the cords or connecting wires and result in a fire or electrical shock. Do not carry the printer with paper loaded in it. The paper could fall out and cause an injury. When setting the printer on the floor or a stand, make sure not to get your fingers or hands pinched under the printer feet. <p>Power supply</p>  <ul style="list-style-type: none"> Do not operate the power switch or plug in/unplug the power cord with wet hands. Doing so could result in electric shock. 	<p>Power cord</p>  <ul style="list-style-type: none"> Keep the power cord away from hot devices. Getting the power cord close to hot devices could cause the cord's covering to melt and cause a fire or electrical shock.   <ul style="list-style-type: none"> When unplugging the power cord from the outlet, be sure to hold it by the plug. Pulling it by the cord could expose or break the core wires and cause a fire or electric shock. The power cord set that comes with the printer is especially made for this printer. Do not use it with any other electrical devices. <p>Top cover</p>  <ul style="list-style-type: none"> Be careful not to get your fingers pinched when opening or closing the top cover. Also be careful the top cover does not slip off and drop. <p>Print head</p>   <ul style="list-style-type: none"> The print head is hot after printing. Be careful not to get burned when replacing paper or cleaning immediately after printing. Touching the edge of the print head immediately after printing could result in injury. Use caution when replacing the label or cleaning the print head. You should not replace the print head without having received the proper training. 	<p>Loading paper</p>  <ul style="list-style-type: none"> When loading roll paper, be careful not to get your fingers pinched between the paper roll and the supply unit. <p>When not using the printer for a long time</p>  <ul style="list-style-type: none"> When not using the printer for a long time, unplug the power cord from the outlet to maintain safety. <p>During maintenance and cleaning</p>  <ul style="list-style-type: none"> When maintaining and cleaning the printer, unplug the power cord from the outlet to maintain safety.

Precautions for Installation and Handling

Printer operation can be affected by the printer environment.

Refer to the following instructions for installation and handling of CG4 Series printer.

Select a Safe Location

Place the printer on a surface that is flat and level.

If the surface is not flat and level, this may result in poor print quality. This may also cause malfunction and shorten the life span of the printer.

Do not place the printer on a location that produces vibration.

Giving serious vibration or shock to the printer may cause malfunction and shorten the life span of the printer.

Keep the printer out of high temperature and humidity.

Avoid locations subject to extreme or rapid changes in temperature or humidity.

Do not place the printer in a location subject to water or oil.

Do not place the printer in a location where it will be splashed with water or oil. Water or oil entering inside the printer may cause a fire, electric shock, or malfunction.

Avoid dust.

Dust build up may result in poor print quality.

Keep out of direct sunlight.

This printer has a built-in optical sensor. Exposure to direct sunlight will make the sensor less responsive and may cause the label to be sensed incorrectly. Close the top cover when printing.

Power Supply

This printer requires an AC power supply.

Be sure to connect the printer to an AC power supply via the supplied AC adapter.

Connect the power cord to a grounded power outlet.

Make sure that the printer is plugged into a grounded power outlet.

Provide a stable source of electricity to the printer.

When using the printer, do not share its power outlet with other electrical devices which could cause power fluctuations and performance issues with your printer.

Table of Contents

Checking Accessories	1-1
About the Box	1-1
Names of Parts	1-2
Turning On the Power	2-1
Power Setting.....	2-1
Basic Specifications	3-1
SATO Group of Companies	4-1
SATO Group of Companies	4-2

1

CHECKING ACCESSORIES

Make sure that you have received all of the following items in the package. If there are any accessories missing, contact your SATO reseller.



User documents
(Quick Guide, warranty)

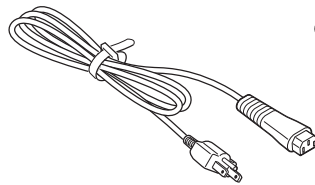

AC power cord

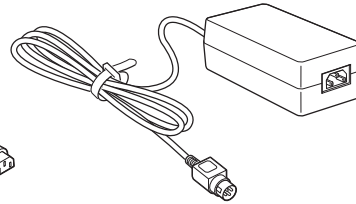

AC adapter

ABOUT THE BOX

Please retain both the box in which the printer was packed, and the cushioning material (cushions that hold the printer in place). If you need to send in the printer for repair, repack it in this box.

NAMES OF PARTS

Front view



① **Operator panel**

It consists of two contact buttons and two LED indicators (green and red).

② **Top cover**

Open this cover to load the media and ribbon.

③ **Cover open/close latch**

Pull these latches on both sides of the printer forward to open the Top cover of the printer.

④ **Media ejection slot**

Opening for media output.

⑤ **POWER button**

Press this button to turn the power on or off.

⑥ **FEED/LINE button**

Press this button to select the printer status (online/ offline) or to feed the media.

⑦ **ERROR LED indicator**

The LED lights or blinks red when an error is detected in the printer.

During printer configuration setting, the ERROR indicator responds in conjunction with the ON LINE (POWER) indicator to show the modes of the printer.

⑧ **ON LINE (POWER) LED indicator**

The LED lights green when the printer is online and blinks green when the printer is offline.

During printer configuration setting, the ON LINE (POWER) indicator responds in conjunction with the ERROR indicator to show the modes of the printer.

Back view

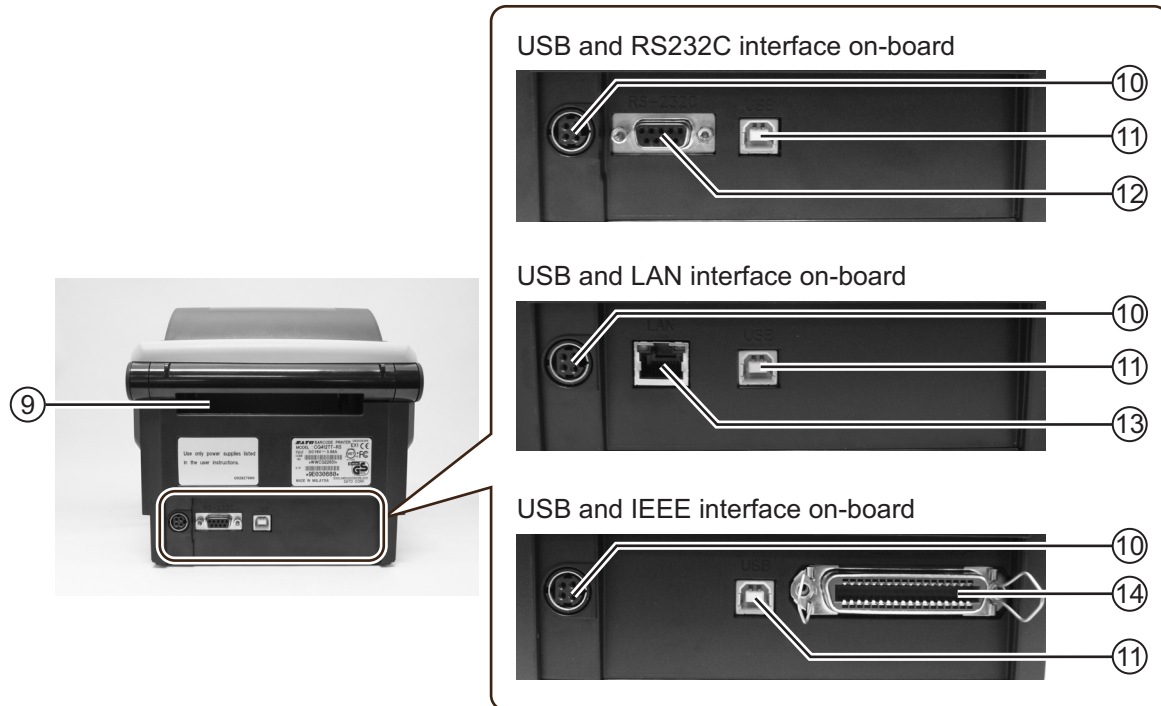

⑨ **Media inlet**

An opening for Fan-folded media or media from unwinder to feed in to the printer.

⑩ **DC input power terminal**

Supplies power to the printer by inserting the power cable via the AC adapter.

⑪ **USB interface terminal**

To connect printer to the host computer using the USB interface.

⑫ **RS-232C interface terminal**

To connect printer to the host computer using RS-232C interface.

Or, to connect the optional Keypad, Scanner or Smart keyboard to the printer.

⑬ **LAN interface terminal**

To connect printer to the host computer using LAN interface.

⑭ **IEEE interface terminal**

To connect printer to the host computer using IEEE interface.

Internal view when Top cover is opened

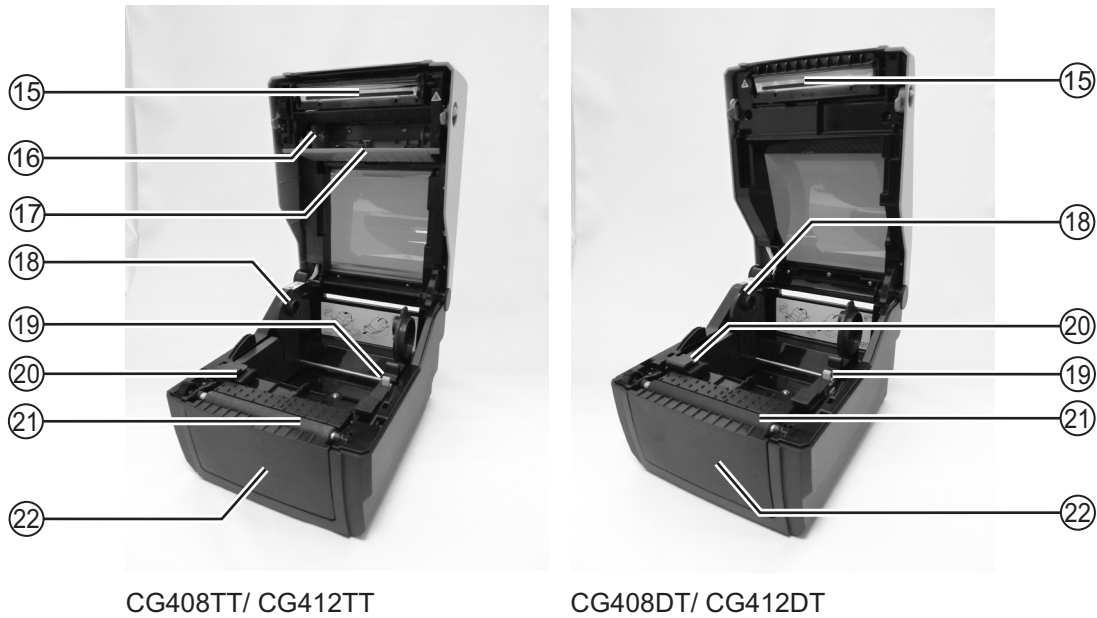

CG408TT/ CG412TT

CG408DT/ CG412DT

⑮ **Print head**

This component is used to print on the media. Perform maintenance at regular intervals.

⑯ **Ribbon unit**

Used to load the ribbon and wind up the used ribbon.

⑰ **Pull out lever**

This is used to pull out the ribbon unit from the top cover for ribbon loading.

⑱ **Roll media holder**

To hold the roll media.

⑲ **Media guide slide lever**

Set to meet the size of the media used.

⑳ **Media guide and I-Mark/ Gap sensor**

A guide for the media to feed properly.

Detects the I-Mark on the media or gap of the label.

㉑ **Platen roller**

This roller feeds the media. Perform maintenance at regular intervals.

㉒ **Optional device compartment**

Used to install optional cutter or dispenser unit.

When Top cover is opened (Cutter Type, Optional)

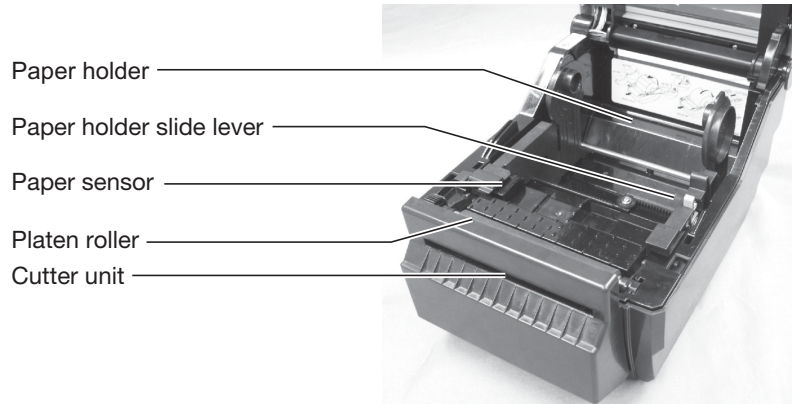

When Top cover is opened (Dispenser Type, Optional)

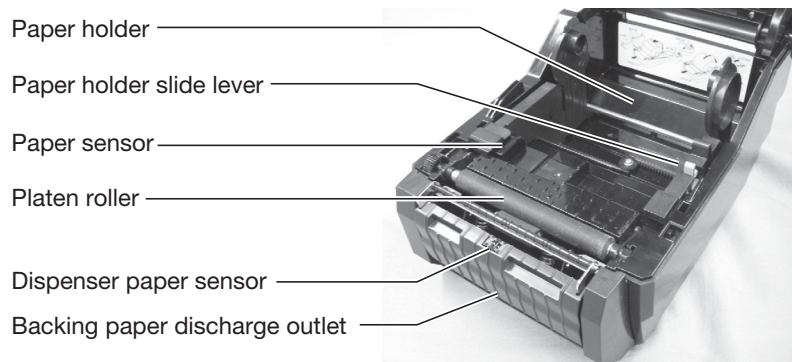

(When the dispenser unit is open)

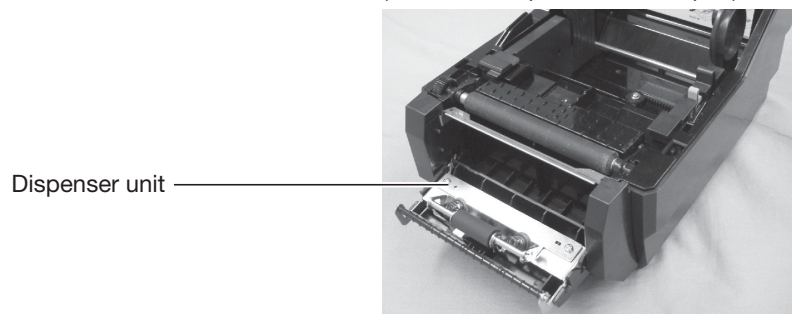

When Top cover is opened (Linerless Type, Optional)

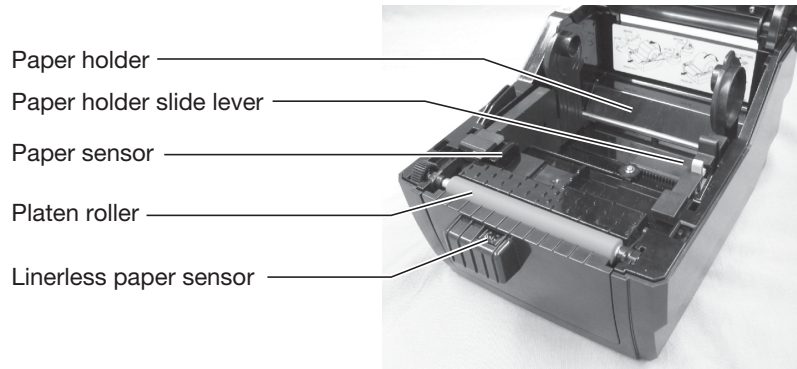

2

TURNING ON THE POWER

POWER SETTING

Connect the DC power cord of the AC adapter to the printer and turn on the power.

1. Connect the AC power cord to the AC adapter.

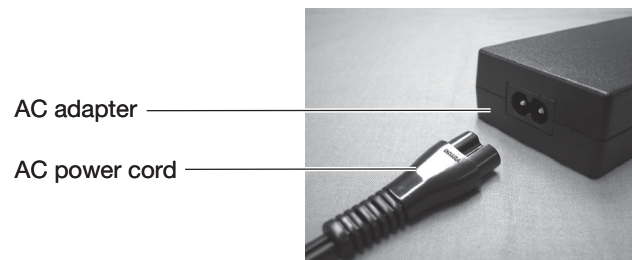

Section 2: Turning On the Power

2. Connect the printer to the AC adapter. Connect the AC adapter to the AC power outlet. When connecting the DC power cord to the printer's power connector, make sure the DC power cord connector is oriented properly. When connecting the DC power cord to the printer connector, use one hand to hold the printer while using the other hand to plug in the cord

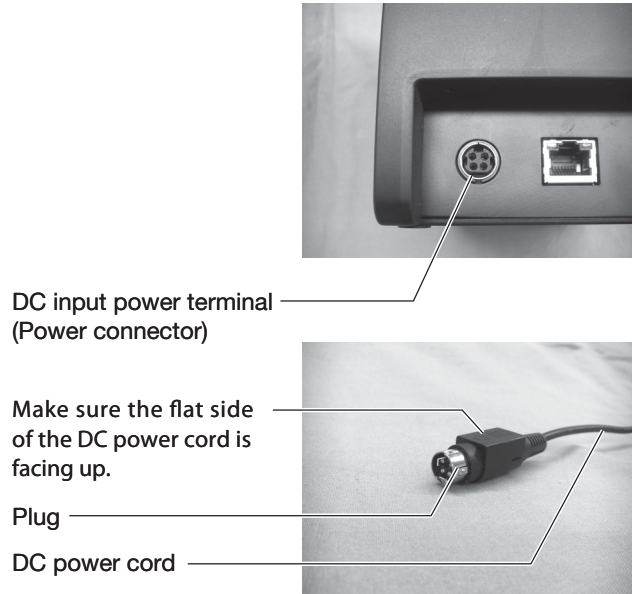

3. Press the POWER button on the operation panel of the printer. The ON LINE (POWER) lamp is on. Check that the ON LINE (POWER) lamp is on.

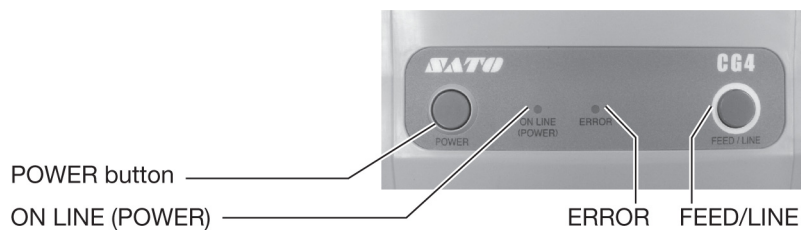

4. Press the POWER button to turn off the printer. When the power is off, the ON LINE (POWER) lamp turns off.

CAUTION



- The power cord set supplied with this printer is only for use with this printer. Do not use it for other electrical products.
- Do not operate the POWER button or plug in/unplug the power cord with wet hands. Doing so could result in electric shock.

3

BASIC SPECIFICATIONS

Model name	CG408 DT	CG412 TT	CG408 TT	CG412 TT
Printing method	Direct Thermal		Thermal Transfer (Direct Thermal/ Thermal Transfer)	
Head density (resolution)	203 dpi (8 dots/ mm)	305 dpi (12 dots/ mm)	203 dpi (8 dots/ mm)	305 dpi (12 dots/ mm)
Printing effective area	4.09" wide x 11.81" pitch (104 mm wide x 300 mm pitch)			
Unprintable area	<p>Label: Length direction Upper: 0.06" (1.5 mm) Lower: 0.06" (1.5 mm) (Not including backing paper) Width direction Left: 0.06" (1.5 mm) Right 0.06" (1.5 mm) (Not including backing paper)</p> <p>Linerless label Length direction Upper: 0.16" (4.0 mm) Lower: 0.06" (1.5 mm) Width direction Left: 0.06" (1.5 mm) Right: 0.06" (1.5 mm)</p>			
Printing speed	1.97, 2.95, or 3.94 inches/second (50, 75 or 100 mm/second) (Setting: 2, 3, 4) * Printing speed varies, depending on paper type and usage environment.			
Paper type / Paper shape	Roll paper (Face-out or face-in winding) We recommend using paper manufactured by SATO.			
Paper thickness	60 to 190µm (0.06 to 0.19 mm)			

Model name	CG408 DT	CG412 TT	CG408 TT	CG412 TT
Label size	<p>Label Continuous type Width: 0.87 to 4.21 in. (Backing paper 0.98 to 4.33 in.); 22 to 107 mm (Backing paper 25 to 110 mm) Pitch: 0.28 to 11.81 in. (Backing paper 0.39 to 11.93 in.); 7 to 300 mm (Backing paper 10 to 303 mm)</p> <p>Cutter type Width: 0.87 to 4.21 in. (Backing paper 0.98 to 4.33 in.); 22 to 107 mm (Backing paper 25 to 110 mm) Pitch: 0.87 to 11.81 in. (Backing paper 0.98 to 11.93 in.); 22 to 300 mm (Backing paper 25 to 303 mm)</p> <p>Dispenser type Width: 0.87 to 4.21 in. (Backing paper 0.98 to 4.33 in.); 22 to 107 mm (Backing paper 25 to 110 mm) Pitch: 0.87 to 3.94 in. (Backing paper 0.98 to 4.06 in.); 22 to 100 mm (Backing paper 25 to 103 mm)</p> <p>Tear-off type Width: 0.87 to 4.21 in. (Backing paper 0.98 to 4.33 in.); 22 to 107 mm (Backing paper 25 to 110 mm) Pitch: 0.87 to 11.81 in. (Backing paper 0.98 to 11.93 in.); 22 to 300 mm (Backing paper 25 to 303 mm)</p> <p>Linerless type (label without backing paper) Width: 0.87 to 4.33 in.; 22 to 110 mm Pitch: 0.87 to 3.94 in.; 22 to 100 mm</p> <p>Non-adhesive label Continuous type Width: 0.98 to 4.33 in.; 25 to 110 mm Pitch: 0.39 to 11.81 in.; 10 to 303 mm</p> <p>Cutter type Width: 0.98 to 4.33 in.; 25 to 110 mm Pitch: 0.98 to 11.81 in.; 25 to 303 mm</p> <p>Tear-off type Width: 0.98 to 4.33 in.; 25 to 110 mm Pitch: 0.98 to 11.81 in.; 25 to 303 mm</p>			
Outer diameter of paper or Roll size	Maximum \varnothing 5.04" (\varnothing 128 mm) Inner diameter of roll core: \varnothing 1.5" (\varnothing 40 mm)			

Model name	CG408 DT	CG412 TT	CG408 TT	CG412 TT
Ribbon size Ribbon type Ribbon winding direction	-		Length: 328.08 feet; 100 m Width: 3.94 in. +/- 0.02 in.; 110 +/- 0.5 mm Outer diameter: Maximum \varnothing 1.5 in.; \varnothing 38 mm (Inner diameter of ribbon core: \varnothing 0.50 in.; \varnothing 12.7 mm) Winding direction: Face out Ribbon winding method: Ribbon core winding method * We recommend use of carbon ribbon manufactured or specified by SATO.	
Label issuing mode	Standard: Continuous mode, Tear off mode, Sensor-off mode Option: Dispenser mode, Cutter mode, Linerless mode			
Dimensions	7.05 (W) x 9.37 (D) x 6.81 (H) in. 179 (W) x 2238 (D) x 173 (H) mm *Excluding the protrusion portion.			
Weight	3.75 pounds; 1.7 kg		4.19 pounds; 1.9 kg	
Power specifications	AC adapter Input power voltage: AC 100V to 240V +/-10% (full range) Frequency: 50/60Hz Output power voltage: DC 19V Power consumption Input power voltage conditions: AC 100V At peak: 50 W (at 30% printing ratio) During standby: 2.5W			
Environmental conditions (temperature and humidity)	Operating environment: 39.2 to 100.4°F; 4 to 38°C; 30 to 80% RH (However, no condensation) Storage environment: 14.0 to 140°F; -10 to 60°C; 15 to 85% RH (However, no condensation) (Not including ribbon, labels, and other supplies)			
Interface	Select one of the following (The factory will provide the unit with the selected interface.) 1. USB (B type) and RS-232C (D-SUB 9-pin) 2. USB (B type) and LAN (10 BASE-T/100 BASE-TX auto switching) 3. USB (B type) and IEEE1284			
Options	Cutter unit, Dispenser unit (with dispenser paper sensor), RTC kit, Non-cutter unit for linerless label, Simplified input Keypad, TSC Smart Keyboard, 1D barcode scanner			
LED	1. Error: (Red) 2. ON LINE (POWER): (Green)			
Operation button	[POWER], [FEED/LINE]			
Paper length detection sensor	I-mark sensor (Reflective type) Label gap sensor (Transmissive type)			

Section 3: Basic Specifications

Model name	CG408 DT	CG412 TT	CG408 TT	CG412 TT
Barcode	UPC-A/UPC-E, JAN/EAN, CODE39, CODE93, CODE128, GS1-128 (UCC/EAN-128), CODABAR (NW-7), ITF, Industrial 2 of 5, Matrix 2 of 5, BOOKLAND, MSI, POSTNET, GS1 DataBar (RSS) * GS1 DataBar is the new version of RSS-14.			
2D barcode	PDF417 (Ver. 2.4), MAXI code (Ver. 3.0), QR code, GS1 DataMatrix (ECC200)			
Composite symbol	EAN-13 Composite (CC-A/CC-B) EAN-8 Composite (CC-A/CC-B) UPC-A Composite (CC-A/CC-B) UPC-E Composite (CC-A/CC-B) GS1-128 Composite (CC-A/CC-B/CC-C) GS1 DataBar Composite (CC-A/CC-B) GS1 DataBar Truncated Composite (CC-A/CC-B) GS1 DataBar Stacked Composite (CC-A/CC-B) GS1 DataBar Stacked Omni-Directional Composite (CC-A/CC-B) GS1 DataBar Limited Composite (CC-A/CC-B) GS1 DataBar Expanded Composite (CC-A/CC-B) GS1 DataBar Expanded Stacked Composite (CC-A/CC-B) * GS1 DataBar is the new version of RSS-14.			
Standard installed fonts				
Bitmap font	U font 5 x 9 dots (alphanumeric characters and symbols) S font 8 x 15 dots (alphanumeric characters and symbols) M font 13 x 20 dots (alphanumeric characters and symbols) WB font 18 x 30 dots (alphanumeric characters and symbols) WL font 28 x 52 dots (alphanumeric characters and symbols) XU font 5 x 9 dots (alphanumeric characters and symbols) XS font 17 x 17 dots (alphanumeric characters and symbols) XM font 24 x 24 dots (alphanumeric characters and symbols) XB font 48 x 48 dots (alphanumeric characters and symbols) XL font 48 x 48 dots (alphanumeric characters and symbols)			
	OCR-A 15 x 22 dots (alphanumeric and symbols) OCR-B 20 x 24 dots (alphanumeric and symbols)		OCR-A 22 x 33 dots (alphanumeric and symbols) OCR-B 30 x 36 dots (alphanumeric and symbols)	
	Simplified Chinese (2.6 MB) Gothic type GB2312 24 x 24 dots			
	Korean (1.6 MB) Gothic type KSX1001 16 x 16 dots Mincho type KSX1001 24 x 24 dots			
	Rasterized font CG Times (alphanumeric and symbols) CG Triumvirate (alphanumeric and symbols)			
Outline font	Alphanumeric and symbols			
Printing direction (Characters and barcode)	Characters: 0°, 90°, 180°, 270° Barcode: Parallel 1 (0°), Parallel 2 (180°), Serial 1 (90°), Serial 2 (270°)			
Barcode ratio	1:2, 1:3, 2:5, Free specification			

Model name	CG408 DT	CG412 TT	CG408 TT	CG412 TT
Magnification ratio (Characters and barcode)	Characters: Vertical 1 to 12 times, horizontal 1 to 12 times Barcode: 1 to 12 times			
Standard functions	<ol style="list-style-type: none"> 1. Status return function 2. Graphic function 3. Sequential number function 4. Form overlay function 5. Custom character registration function 6. Black/white inversion function 7. Ruled line function 8. Format registration function 9. Zero slash switching function 			
Self-diagnostic function	<ol style="list-style-type: none"> 1. Paper end detection 2. Cover open detection 3. Test print 4. Ribbon end detection (for thermal transfer type only) 5. Cutter error (when the cutter unit is installed) 			
Noise (EMC) standard	FCC15B Class B			
Safety standards	UL60950-1(2001), CSA22.2 No. 60950-1-03			

Notice regarding the registered trademarks and trademarks of other companies:
QR Code is a registered trademark of DENSO WAVE INCORPORATED.

4

SATO GROUP OF COMPANIES

SATO GROUP OF COMPANIES

Asia Pacific & Oceania Region

SATO ASIA PACIFIC PTE. LTD.

438A Alexandra Road #05-01/04,
Alexandra Technopark, Singapore 119967
Tel: +65-6271-5300
Fax: +65-6273-6011
Email: technical@satoasiapacific.com
www.satoasiapacific.com

SATO AUTO-ID MALAYSIA SDN. BHD.

No.25, Jalan Pemberita U1/49,
Temasya Industrial Park, Section U1,
40150 Shah Alam, Selangor Darul Ehsan,
Malaysia
Tel: +60-3-7620-8901
Fax: +60-3-5569-4977
Email: service@satosms.com.my
www.satoasiapacific.com

SATO AUTO-ID (THAILAND) CO., LTD.

292/1 Moo 1 Theparak Road,
Tumbol Theparak, Amphur Muang,
Samutprakarn 10270, Thailand
Tel: +66-2-736-4460
Fax: +66-2-736-4461
Email: technical@satothailand.com
www.satothailand.co.th

SATO SHANGHAI CO., LTD.

307 Haining Road, ACE Bldg,
10th Floor, Hongkou Area, Shanghai,
China 200080
Tel: +86-21-6306-8899
Fax: +86-21-6309-1318
Email: tech@satochina.com
www.satochina.com

SATO ASIA PACIFIC PTE. LTD.

Korea Representative Office

6F, Korea Housing Center,
Yeouido-dong 45-11, Yeongdeungpo-gu,
Seoul, Korea 150-736
Tel: +82-2-761-5072
Fax: +82-2-761-5073
Email: technical@satoasiapacific.com
www.satoasiapacific.com

SATO ASIA PACIFIC PTE. LTD.

India Representative Office

Regus Level 2, Connaugh Place,
Bund Garden Road, Pune. 411001, India
Tel: +91-20-4014-7747
Fax: +91-20-4014-7576
Email: technical@satoasiapacific.com
www.satoasiapacific.com

SATO AUSTRALIA PTY LTD.

1/1 Nursery Avenue, Clayton Business
Park, Clayton, VIC 3168 Australia
Tel: +61-3-8814-5330
Fax: +61-3-8814-5335
Email: enquiries@satoaustralia.com
www.satoaustralia.com

SATO NEW ZEALAND LTD.

30 Apollo Drive, Mairangi Bay
Auckland, New Zealand
Tel: +64 9-477-2222
Fax: +64-9-477-2228
Email:
global.warranty@satonewzealand.com
www.satonewzealand.com

European Region

SATO LABELLING SOLUTIONS EUROPE GmbH (BELGIUM)

Leuvensesteenweg 369,
1932 Sint-Stevens-Woluwe, Belgium
Tel: +32-2-788-80-00
Fax: +32-2-788-80-80
Email: info@nl.satoeurope.com
www.satoeurope.com

SATO LABELLING SOLUTIONS EUROPE GmbH (GERMANY)

Ersheimer Straße 71,
69434 Hirschhorn, Germany
Tel: +49-6272-9201-160
Fax: +49-6272-9201-347
Email: service@de.satoeurope.com
www.satoeurope.com

SATO LABELLING SOLUTIONS EUROPE GmbH (NORWAY)

Hovfaret 4 0275 Oslo, Norway
Tel.: +47-225-106-70
Fax: +47-225-106-71
Email: kundeservice@satornorge.com
www.satoeurope.com

SATO LABELLING SOLUTIONS EUROPE GmbH (NETHERLANDS)

Techniekweg 1b, 3481 MK Harmelen,
Netherlands
Tel.: +31-348-444437
Fax: +31-348-446403
Email: info@nl.satoeurope.com
www.satoeurope.com

SATO LABELLING SOLUTIONS EUROPE GmbH (ITALY)

Viale Europa 39/1,
20090 Cusago, Milano, Italy
Tel.: +39-2-903-944-64
Fax: +39-2-903-940-35
Email: info@it.satoeurope.com
www.satoeurope.com

SATO LABELLING SOLUTIONS EUROPE GmbH (SWITZERLAND)

Allmendstraße 19,
8320 Fehraltorf, Switzerland
Tel: +41-44-954-84-00
Fax: +41-44-954-84-09
Email: info@ch.satoeurope.com
www.satoeurope.com

SATO LABELLING SOLUTIONS EUROPE GmbH (AUSTRIA)

Niederlassung Austria
Jochen-Rindt-Straße 13
1230 Wien, Austria
Tel: +43-2762-52690
Fax: +43-2762-52018
Email: info@at.satoeurope.com
www.satoeurope.com

SATO LABELLING SOLUTIONS EUROPE GmbH (DENMARK)

Naverland 29A DK-2600
Glostrup, Denmark
Tel.: +45-43204700
Fax: +45-43204709
Email: info@dk.satoeurope.com
www.satoeurope.com

SATO POLSKA SP. Z O.O.

ul. Wroclawska 123, Radwanice,
55-015 Św. Katarzyna, Poland
Tel: +48-71-381-03-60
Fax: +48-71-381-03-68
Email: info@sato.pl
www.sato.pl

SATO IBERIA S.A.

Dels Coralls Nous, 35-39
Pol. Can Roqueta, 08202 - Sabadell
Barcelona, Spain
Tel: +34-902-333-341
Fax: +34-902-333-349
Email: info@es.satoeurope.com
www.satoeurope.com

SATO FRANCE S.A.S.

Parc d'Activités, Rue Jacques Messenger,
59 175 Templemars, France
Tel: +33-3-20-62-96-40
Fax: +33-3-20-62-96-55
www.satoeurope.com

SATO UK LTD.

Valley Road, Harwich,
Essex CO12 4RR, United Kingdom
Tel: +44-1255-240000
Fax: +44-1255-240111
Email: enquiries@satouk.com
www.satouk.com

American Region

SATO AMERICA, INC.

10350-A Nations Ford Road, Charlotte,
NC 28273, U.S.A.
Tel: +1-704-644-1650
Fax: +1-704-644-1662
www.satoamerica.com

SATO LABELING SOLUTIONS AMERICA, INC.

1140 Windham Parkway, Romeoville,
Illinois 60446, U.S.A.
Tel: +1-800-645-3290
Fax: +1-630-771-4210
www.satolabeling.com

- Extensive contact information of worldwide SATO operations can be found on the Internet at www.satoworldwide.com

Free Manuals Download Website

<http://myh66.com>

<http://usermanuals.us>

<http://www.somanuals.com>

<http://www.4manuals.cc>

<http://www.manual-lib.com>

<http://www.404manual.com>

<http://www.luxmanual.com>

<http://aubethermostatmanual.com>

Golf course search by state

<http://golfingnear.com>

Email search by domain

<http://emailbydomain.com>

Auto manuals search

<http://auto.somanuals.com>

TV manuals search

<http://tv.somanuals.com>