

WATO

DCS & Labeling Worldwide

GT Series



OPERATOR'S MANUAL



SATO ASIA PACIFIC PTE. LTD.
438A ALEXANDRA ROAD
#05-01/02 ALEXANDRA TECHNOPARK
SINGAPORE 119967
Tel: (65) 6271 5300
Fax: (65) 6273 6011
Sales Hotline: (65) 6276 2722
Service Hotline: (65) 6273 6455
Email: sales@satoasiapacific.com
Website: www.satoworldwide.com

Copyright 2003
SATO Asia Pacific Pte. Ltd.

Warning : This equipment complies with the requirements in Part 15 of FCC rules for a Class A computing device. Operation of this equipment in a residential area may cause unacceptable interference to radio and television reception requiring the operator to take whatever steps necessary to correct the interference. All rights reserved. No part of this document may be reproduced or issued to third parties in any form whatsoever without the express permission of SATO Asia PacificPte. Ltd. The materials in this document are provided for general information and are subjected to change without prior notice. SATO Asia Pacific Pte. Ltd. assumes no responsibilities for any errors that may appear.

TABLE OF CONTENTS

1 OVERVIEW

1.1	General Specifications	1-2
-----	------------------------------	-----

2 INSTALLATION

Safety Precautions.....	2-2
2.1 Unpacking.....	2-4
2.1.1 <i>Included Accessories</i>	2-5
2.1.2 <i>Parts Identification</i>	2-6
2.2 Loading the Carbon Ribbon.....	2-10
2.2.1 <i>Removing the Carbon Ribbon</i>	2-11
2.2.2 <i>OPTION: Using A Paper Tube to Wind Used Ribbon</i>	2-12
2.3 Loading Labels And Tags	2-13
2.3.1 <i>Loading Roll Paper</i>	2-14
2.3.2 <i>Loading Fanfold Paper</i>	2-17
2.3.3 <i>Loading Fanfold Paper under the printer</i>	2-19
2.3.4 <i>Adjusting the paper sensor</i>	2-21
2.4 Replacing the Print Head.....	2-22
2.5 Turning the printer ON/OFF	2-23

3 CONFIGURATION AND OPERATION

3.1	Operating Modes.....	3-1
3.2	The Operation Panel	3-2
3.3	Screen Icons And Their Meaning	3-3
3.4	ONLINE And OFFLINE Modes.....	3-5
3.4.1	<i>Online Mode</i>	3-5
3.4.2	<i>Offline Mode</i>	3-5
3.5	User Mode.....	3-6
3.5.1	<i>Entering User Mode</i>	3-6
3.5.2	<i>Setting Buzzer Volume, Print Pitch, Print Offset, Print Darkness</i>	3-7
3.5.2	<i>Setting Print Speed</i>	3-7
3.5.3	<i>Setting Print Darkness</i>	3-8
3.5.4	<i>Setting Print Offset</i>	3-8
3.5.5	<i>Setting Zero Slash Changeover</i>	3-9
3.5.6	<i>Setting JIS Kanji Code Changeover*</i>	3-9
3.5.7	<i>Setting Kanji Font Style*</i>	3-9
3.5.7	<i>Setting Proportional Pitch</i>	3-10
3.6	Interface Mode.....	3-11
3.6.1	<i>Entering Interface Mode</i>	3-11
3.6.2	<i>Enabling Interface Card Configuration</i>	3-11
3.6.3	<i>Assigning An Interface Card For Printing</i>	3-12
3.6.4	<i>Selecting The Data Input Port</i>	3-12
3.6.5	<i>Enabling or Disabling The Status Return Port</i>	3-12

3.7	Cartridge Mode	3-13
3.7.1	Entering Cartridge Mode	3-13
3.7.2	Cartridge Formatting Option	3-13
3.7.3	Start Cartridge Formatting	3-13
3.7.4	Cartridge Formatting Progress	3-14
3.8	SEMBL Mode	3-15
3.8.1	Entering SEMBL Mode	3-15
3.8.2	Selecting The Start Program	3-15
3.8.3	The SEMBL Status Screen	3-16
3.9	Advanced Mode	3-17
3.9.1	Entering Advanced Mode	3-17
3.9.2	Selecting The Print Density	3-17
3.9.3	Setting the Automatic Detection of Optional Units	3-17
3.9.4	Choosing Continuous or Tear Off Operation	3-18
3.9.5	Backfeed Operation Settings	3-18
3.9.6	Configuring the Internal Winding Unit	3-18
3.9.7	Setting the Print Mode	3-19
3.9.8	Configuring the Paper Sensor	3-19
3.9.9	Configuring the Paper Sensor Type	3-19
3.9.10	Turning Head Check Function ON/OFF	3-20
3.9.11	Choosing the Type of Head Check	3-20
3.9.12	Enabling/Disabling External Signal Output	3-21
3.9.13	Selecting the Type of External Signal Output	3-21
3.9.14	Selecting Reprint via External Signal Output	3-21
3.9.15	Using the Auto Online Feature	3-22
3.9.16	Enabling Auto Feed	3-22
3.9.17	Enabling Auto Feed On Error	3-22
3.9.18	Specifying the Protocol Code Format	3-23
3.9.19	Specifying The SEMBL Start Mode	3-23
3.9.20	Specifying The SEMBL Auto Start Program	3-23
3.10	HEX Dump Mode	3-24
3.10.1	Entering HEX Dump Mode	3-24
3.10.2	Selecting Data To Dump	3-24
3.10.3	Controlling the Hex Dump Mode	3-24
3.11	Test Print Mode	3-25
3.11.1	Entering Test Print Mode	3-25
3.11.1	Choosing What The Test Print Contains	3-25
3.11.2	Setting Test Print Width for Configuration, Barcode and Head Check	3-26
3.11.3	Setting the Size of the Factory Test Print	3-26
3.11.4	Starting the Test Print	3-26
3.12	Overview of All Modes	3-27
3.13	Restoring Factory DeFault Settings	3-37
3.13.1	Entering Default Mode	3-37
3.13.2	If You Chose to Reset Printer Settings	3-38
3.13.2	If You Chose Alt Protocol Code	3-38
3.13.3	Completion of Default Setting	3-38
3.14	Understanding Continuous Print and Tear Off Operations	3-39

4 CLEANING AND MAINTENANCE

4.1	Introduction	4-1
4.2	Cleaning The Print Head, Platen and Rollers	4-1
4.3	How To Clean The Printer (Cleaning SET).....	4-2
4.4	How To Clean The Printer (Cleaning SHEET).....	4-3
4.5	Adjusting Print Quality	4-4
4.5.1	<i>Adjusting Print Darkness</i> 4-4	
4.5.2	<i>Adjusting Print Speed</i> 4-5	

5 INTERFACE SPECIFICATIONS

5.1	Interface types.....	5-1
5.2	Interface Card DIP SWITCH Settings (RS-232C)	5-2
5.3	Interface Card DIP SWITCH Settings (LAN).....	5-3
5.4	Interface Card DIP SWITCH Settings (Wireless LAN)	5-3
5.5	Interface Card DIP SWITCH Settings (Mini LAN).....	5-4
5.6	Serial Interface SPECIFICATIONS (RS-232C).....	5-5
5.7	READY/BUSY	5-6
5.8	Single Job Buffer	5-7
5.9	Multi Job Buffer	5-8
5.10	X-ON/X-OFF	5-8
5.11	Single Job Buffer	5-10
5.12	Multi Job Buffer	5-11
5.13	Driver Protocol	5-11
5.14	Status 3	5-24
5.15	Multi Job Buffer	5-25
5.16	Reference Flowchart.....	5-32
5.17	Parallel Interface SPECIFICATIONS (Centronics).....	5-33
5.18	Single Job Buffer	5-35
5.19	Multi Job Buffer	5-37
5.20	IEEE 1284 Interface	5-39
5.21	Interface Signals	5-42
5.22	Single Job Buffer	5-43
5.23	Multi Job Buffer	5-45
5.24	Driver Protocol	5-47

TROUBLESHOOTING

6.1	Initial Checklist	6-1
6.2	Using the Centronics (Parallel) Interface	6-1
6.3	Using the RS232C (SERIAL) Interface	6-3
6.4	Understanding the STATUS INDICATORS	6-4
6.5	Understanding the LCD Error Messages	6-5
6.6	LCD Warning Messages	6-10
6.7	Troubleshooting Guide	6-11

OPTIONAL ACCESSORIES

7.1	Introduction	7-1
7.2	Available Interface Boards	7-1
7.3	Label Management Accessories	7-2
7.3	PCMCIA Memory Cartridge	7-3
7.3.1	<i>Installing the memory card</i>	7-3

1

OVERVIEW

Thank you for your investment in this SATO printer product.

This Operator's Manual contains basic information about the installation, setup, configuration, operation and maintenance of the printer.

A total of seven topics are covered herein, and they are organized as follows:

- Section 1: Overview**
- Section 2: Installation**
- Section 3: Configuration and Operation**
- Section 4: Cleaning and Maintenance**
- Section 5: Interface Specifications**
- Section 6: Troubleshooting**
- Section 7: Optional Accessories**

It is recommended that you become familiar with each section before installing and maintaining the printer. Refer to the **Table Of Contents** at the front of this manual to search for the relevant information needed. All page numbers in this manual consist of a section number followed by the page number within the stated section.

For specialized programming, refer to the separate Programming Manual located on the utility CD-ROM.

1.1 GENERAL SPECIFICATIONS

The SATO GT4xx “e” series of dual use (Thermal Transfer and Direct Thermal) printers are complete, high-performance labeling systems designed for printing tags and labels.

The key features of the GT series are:

- Faster print speed and better print quality than ever
- Large 3-line LCD screen and icon-rich user interface
- Fully configurable without the need for setting DIP switches
- Easy operation via multiple control buttons and status indicators
- Easy upgrading to higher resolution print heads and additional memory by users
- Richer SBPL command set for better control via software/network
- Supports standalone operation via execution of BASIC programs stored in memory
- Supports two I/O connections
- User friendly label and ribbon path
- Ribbon saving feature

All printer parameters are programmable using the front panel controls and via software. All popular bar codes, including 2-D codes, eight human-readable fonts with two Care Symbol fonts and a fast and efficient vector font, are resident in memory, providing literally thousands of combinations of type styles and sizes.

Features of SATO GT4xxe Series Printers

Feature	GT408e	GT412e	GT424e
Print resolution	203dpi for economical labeling solution (user upgradable to higher resolution print assembly)	305dpi for laser quality printing and graphic images	608dpi for laser quality printing and graphic images
Print method	Thermal Transfer and Direct Thermal	Thermal Transfer and Direct Thermal	Thermal Transfer and Direct Thermal
Label sizes supported (using default internal memory)	4 inches (W) by 9.4 inches	4 inches (W) by 9.4 inches	4 inches (W) by 9.4 inches
Label sizes supported (using additional optional PCMCIA memory card)	4 inches (W) by 49.2 inches at 203 dpi	4 inches (W) by 32.8 inches at 305 dpi	4 inches (W) by 32.8 inches at 305 dpi
Integral Cutter unit	Optional	Optional	Optional
Stacker option	Up to 500 3.9 inch (W) by 5.9 inch labels	Up to 500 3.9 inch (W) by 5.9 inch labels	Up to 500 3.9 inch (W) by 5.9 inch labels
Interfaces available	Optional RS-232C, LAN, USB, RFID, IEEE 1284 or high speed RS-232C	Optional RS-232C, LAN, USB, RFID, IEEE 1284 or high speed RS-232C	Optional RS-232C, LAN, USB, RFID, IEEE 1284 or high speed RS-232C

1.1 GENERAL SPECIFICATIONS (CONT'D)

Specification/ Model Name		GT408	GT412	GT424
Print method		Thermal transfer or thermal		
Head density		8 dots/ mm (203 dpi)	12 dots/ mm (305 dpi)	24 dots/ mm (609 dpi)
Print valid range (width)		104 mm x pitch 2500 mm	104 mm x pitch 1500 mm	104 mm x pitch 400 mm
		Not printable for 3 mm from the backside.		
Print speed (Max)		12 inches/sec (Approx 300 mm/sec)	12 inches/sec (Approx 300 mm/sec)	6 inches/sec (Approx 150 mm/sec)
		Note: Maximum speed may be further dependent on the type of print layout, paper, or carbon ribbon in use.		
Paper Thickness		0.060 mm to 0.268 mm supported. Note: Be sure to use only printer supplies manufactured or certified by SATO.		
Label size (mounting and cardboard size)	Standard	Width: 22 to 128 mm (25 to 131 mm) Pitch: 5 to 397 mm (9 to 400 mm)		Note: Supported sizes may be regulated due to the quantity of print jobs or size of paper. Other usage conditions may restrict the range of label sizes supported.
	Tear off	Width: 22 to 128 mm (25 to 131 mm) Pitch: 17 to 397 mm (20 to 400 mm)		
	Peel	Width: 22 to 128 mm (25 to 131 mm) Pitch: 17 to 397 mm (20 to 400 mm)		
	Cutter	Width: 22 to 128 mm (25 to 131 mm) Pitch: 17 to 397 mm (20 to 400 mm)		
	Non-separate	Width: 22 to 128 mm (25 to 131 mm) Pitch: 17 to 397 mm (20 to 400 mm)		
Number of loadable sheets	Roll paper	Maximum external diameter: 200 mm (Approximately 150 m/roll) 3-inch paper tube used Back winding (only front winding for non-separate mode)		
	Fanfold paper	Maximum folded height: 200 mm See the section in this manual on Setting Fanfold Paper		
Carbon ribbon Width Length Thickness of base material Color Winding direction		Be sure to use the specified carbon ribbon manufactured by SATO. 39.5, 45, 59, 76, 84, 92, 102, 111, and 128 mm Use a carbon ribbon that is wider than the paper used. 300 m/roll 4.5 µm Black (standard), also red, blue, purple, and green Front winding and back winding		
Label dispensing modes		Continuous, tear off, peeler, dispenser and non-separate		
Dimensions		W 271 mm x D 455 mm x H 305 mm x (Standard)		
Weight		14 kg (for a standard configuration)		
Power supply		Input voltage: AC 100 V to 240 V ±10% Power consumption: Maximum 200 VA 150 W, print rate 30% (89 VA 40 W on standby)		
Operating Environment		Operational ambient temperature: 0 to 40 °C Operational ambient humidity: 30 to 80% (without condensation) Storing ambient temperature: -5 to 60 °C Storing ambient humidity: 30 to 90% (no condensation) Paper, and carbon ribbon excluded.		

1.1 GENERAL SPECIFICATIONS (CONT'D)

Specification/ Model Name		GT408	GT412	GT424
External interface		Interface board □ Parallel (IEEE1284) □ RS-232C <ul style="list-style-type: none"> • READY/BUSY • XON/XOFF • Status 2/3 • Driver specific protocol • Status 5 □ USB (Ver. 2.0) □ LAN (10BASE-T/ 100BASE-TX automatic changeover) □ Wireless LAN (IEEE802.11b) □ Mini LAN (10BASE-T/ 100BASE-TX automatic changeover) External (EXT) signal interface (14-pin)		
Operation Panel	Buttons	LINE, FEED FUNCTION, 4 navigation buttons (up/down/left/right), ENTER, CANCEL		
	Switch	POWER ON/OFF		
	LCD	Green LCD (with backlight), Vertical 32 dots x horizontal 128 dots, displaying up to five icons at the top of the screen		
	LEDs	POWER, ONLINE, STATUS, LABEL, RIBBON status indicators		
	Adjustment Potentiometer	VOLUME: buzzer loudness adjustment PITCH: print-head pitch adjustment OFFSET: tear off, peel, and cutter stop position adjustment DARKNESS: print density adjustment		
Sensor		Paper sensor: reflection type, penetration type		
Memory cartridge		16 MB FLASH ROM, 4 MB non-volatile user memory		
Print Format		Transmitted from host (computer) or recalled from print formats stored by user on memory card (optional)		
Stored Font Types	Standard	X20 5 x 9 dots (alphanumeric, symbol, and kana) X21 17 x 17 dots (alphanumeric, symbol, and kana) X22 24 x 24 dots (alphanumeric, symbol, and kana) X23 48 x 48 dots (alphanumeric, symbol, and kana) X24 48 x 48 dots (alphanumeric, symbol, and kana) Outline font (alphanumeric, symbol, and kana) OCR-A GT408 15 x 22 dots (alphanumeric and symbol) GT412 22 x 33 dots (alphanumeric and symbol) GT424 44 x 66 dots (alphanumeric and symbol) OCR-B GT408 20 x 24 dots (alphanumeric and symbol) GT412 30 x 36 dots (alphanumeric and symbol) GT424 60 x 72 dots (alphanumeric and symbol)		
	TrueType Fonts	CG Times (alphanumeric and symbol) CG Triumvirate (alphanumeric and symbol)		
	Kanji Fonts (where applicable)	16 x 16 dots (JIS level-1 and -2 kanji sets. Selectable either Mincho or Gothic) 24 x 24 dots (JIS level-1 and -2 kanji sets. Selectable either Mincho or Gothic) 22 x 22 dots (JIS level-1 and -2 kanji sets. Selectable either Mincho or Gothic) 32 x 32 dots (JIS level-1 and -2 kanji sets. Selectable either Mincho or Gothic) 40 x 40 dots (JIS level-1 and -2 kanji sets. Selectable either Mincho or Gothic) Kanji outline font		

1.1 GENERAL SPECIFICATIONS (CONT'D)

Specification/ Model Name		GT408	GT412	GT424
Barcode	One-dimensional code	<ul style="list-style-type: none"> • UPC-A/E, EAN8/13, JAN8/13 • NW-7 • INTERLEAVED 2 of 5 (ITF) • INDUSTRIAL 2 of 5 • MATRIX 2 of 5 • CODE39, CODE93, CODE128 • UCC/EAN128 • Customer barcode • RSS-14 		
	Two-dimensional code	<ul style="list-style-type: none"> • QR code model 2, Micro QR (Ver 8.1) • PDF417 (Ver. 2.4, including micro PDF) • Veri code (Ver. 1.0) • MAXI code (Ver. 3.0) • Data matrix ECC200 (Ver. 2.0) • Synthetic symbol (UPC-A/E, EAN8/13, JAN8/13, CODE39, CODE128 CC-A/B/C supported with RSS-14) 		
Magnification		Vertical 1 to 12 times Horizontal 1 to 12 times (characters) 1 to 12 L (barcodes)		
Rotation		Characters: 0°, 90°, 180°, and 270° Barcode: parallel 1, serial 1, parallel 2, serial 2		
Barcode Ratio		1:2, 1:3, 2:5, arbitrary		
User mode		1. Volume set value indication 2. Print speed 3. Print density 4. Print position correction 5. Zero slash changeover 6. Kanji code changeover 7. Kanji font setting 8. Proportional pitch setting		
Automatic diagnostics		Head check/ Head open/ Paper end/ Ribbon end/ Winding full/ Kanji ROM check/ Test print		
Noise emission	Radiant noise	VCCI Class B		
	Static with-stand pressure	IEC Level 3		
	AC line noise	1000 Vp-p or more (50 nS to 1 µS pulse)		
Optional accessories		<ul style="list-style-type: none"> • Peel unit (with mounting winder) • Cutter unit • Non-separate unit • Simplified peel unit • Internal winding unit • External winding unit • RFID unit • Detection scanner unit • EXT connector (external signal) • Interface boards (serial RS-232C or Parallel IEEE1284) • USB Interface board • LAN (10BASE-T/100BASE-TX), • Wireless LAN (IEEE802.11b), • Mini LAN (10BASE-T/100BASE-TX) 		
Memory cartridge		24 MB		

Note:

All the GT printers use the same command codes. The only differences are the allowable values representing print positions on the label. These values are specified in “dots” and will vary depending upon the resolution of the printer and the amount of memory available for imaging the label.

2

INSTALLATION

This section assists you in unpacking and installing the printer from the shipping container. You will also be guided through a familiarization tour of the main parts and controls. The following information is provided:

- Safety Precautions
- Unpacking and Parts Identification
- Loading the Carbon Ribbon
- Loading Labels and Tags
- Adjusting the Sensors
- Replacing the Print Head
- Turning the Printer ON/OFF

SAFETY PRECAUTIONS

Please read the following information carefully before installing and using the printer

THE CAUTION SYMBOL 

Whenever the triangular Caution logo appears in this manual, pay special attention to the warning(s) cited below it. Failure to abide by the warnings may result in injury or damage to property.

PRINTER PLACEMENT TIPS

- Place the printer on a solid, stable, horizontal surface that is not subject to strong vibrations from adjacent mechanical devices. 
- Avoid shaky or slanting tables, or platforms that are liable to collapse under a heavy weight. If the printer is dropped or damaged, immediately turn off the power, pull out the power plug and contact a service center. In this case, continued use of the printer may cause a fire or electric shocks.
- Avoid installing the printer in direct sunlight, or in dusty, very hot or slippery areas. Also avoid placement in damp, unventilated or humid areas. If condensation forms, immediately turn off the power, and do not use the printer until the condensation disappears. Otherwise the moisture may cause electric shocks.
- Avoid placing the printer near large high-current equipment, as such equipment can cause spikes or undervoltages in the power supply.

- Do not leave containers of water or chemicals around the printer. If any liquid is spilled onto the printer, immediately turn off the power, pull out the power cable from the AC outlet, and contact a sales outlet, dealer, or service center. In this case, continued use of the printer may cause fires or electric shocks. 
- Do not move the printer with any paper loaded. The stack of paper may fall off, causing trips and accidents.
- When laying the printer down, be careful not to catch your foot or fingers under it.
- When moving the printer, be sure to pull out the power cable from the AC outlet, and check that any other external interface cables have been disconnected. Otherwise, the connected cables may be damaged, or may cause trips and falls, in addition to or a fire or electric shocks.

ELECTRICAL PRECAUTIONS

- Do not damage, break, or process the power cable. Hanging heavy objects on it, heating or pulling it may damage the power cable and cause fires or electric shocks.
- When the power cable is damaged (cable conductors are exposed or cut, etc.), contact a sales outlet, dealer, or service center. In this case, continued use of the printer may cause fires or electric shocks.
- Do not process, forcibly bend, twist, or pull the power cable. Continued use of such a cable may cause fires or electric shocks.
- If the printer emits any smoke or peculiar odors at any time, turn it OFF and prevent further usage until you have contacted a qualified service personnel.
- Do not use any other voltage except the specified power voltage for the printer that matches your domestic power supply. Otherwise, it may cause fires or electric shocks.

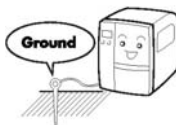
- Do not operate the power switch or handle the power cable with a wet hand.
- Do not insert or drop anything metallic or flammable into the openings of the printer (the cable outlet or mounting hole of the memory cartridge). Otherwise, immediately turn off the power, pull out the power cable, and contact a sales outlet, dealer, or service center. In this case, continued use of the printer may cause fires or electric shocks.
- To reduce electrical risks, be sure to connect the printer to ground before use. Also, try not to share the printer's AC outlet with other electrical equipment, especially those that draw high amounts of current or cause electrical interference. 

GENERAL PRECAUTIONS

- | | |
|--|--|
| <ul style="list-style-type: none"> • The supplied head cleaning liquid is flammable. Never heat it or throw it into a fire. Keep it out of children's reach to avoid accidental consumption. Should this occur, consult a doctor immediately. • When opening/closing the cover, beware of getting your fingers caught. Also, hold the opening/closing cover well so that it will slip and fall. • After printing, the print head remains hot. When replacing paper or cleaning the printer immediately after printing, be careful not to burn yourself. • Touching even the edge of the printer head may cause injuries. When replacing paper or cleaning the printer, be careful not to hurt yourself. • If the printer will not be used for extended periods of time, disconnect the power cable for safety. • When releasing and locking down the printer head, be careful not to catch any other foreign in it except label paper. | <ul style="list-style-type: none"> • Do not disassemble or perform modifications to the printer, as this renders the product unsafe. For maintenance, troubleshooting and repairs, consult a sales outlet, dealer, or service center for help, instead of attempting to perform this yourself. Renewable annual service contracts are available. • When maintaining or cleaning the printer, always disconnect the power cable for safety. • Do not insert your hand or other objects into the cutter. • When loading roll paper, be careful not to catch your fingers between the paper and the feed. • Be careful not to hurt yourself when detaching the back cover of the fanfold through the hole and attaching it. • The simplified cutter is structured as a blade. Be careful not to cut yourself. |
|--|--|

This equipment is a piece of Class B information technology equipment based on the standards of the Voluntary Control Council for Interference by Information Technology Equipment (VCCI). Although this equipment is for use in home environment, if it is used close to a radio or television set, it may cause poor reception. Handle it properly in accordance with the content from the instruction manual.

SECTION 2: INSTALLATION

2.1 UNPACKING

When unpacking the printer, take note of the following:

1 The box should stay right-side up. Lift the printer out of the box carefully.	4 If the printer was been stored in the cold, allow it to reach room temperature before turning it on.
2 Remove the plastic covering from the printer.	5 Set the printer on a solid, flat surface. Inspect the shipping container and printer for any sign of damage that may have occurred during shipping.
3 Remove the accessory items from their protective containers.	

Note

The following illustrations are representative only. Your printer may not be packed exactly as shown, but the unpacking steps are similar.

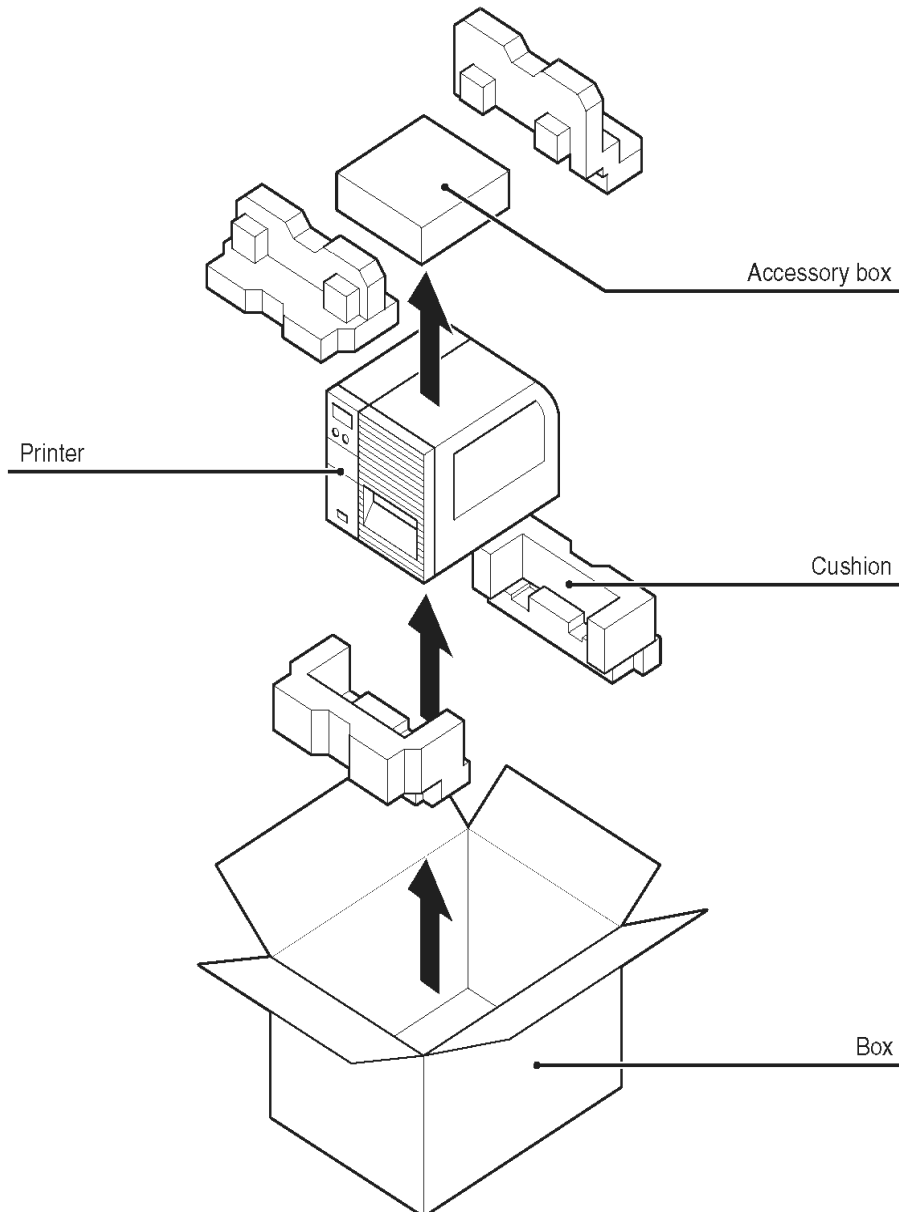

2.1.1 INCLUDED ACCESSORIES

After unpacking the printer, verify that the following materials are in the accessories or packaging:

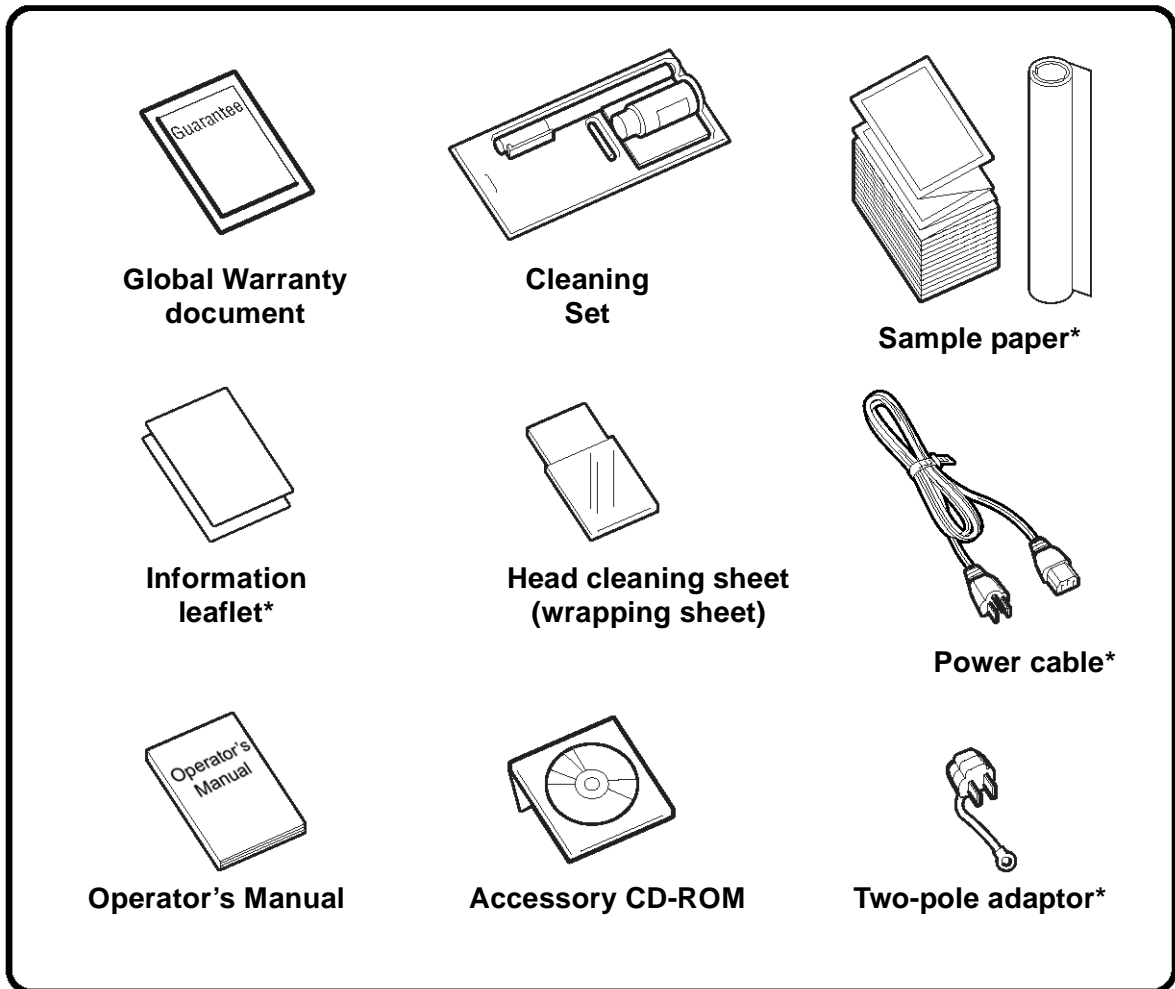

Items marked with an asterisk may be different from what you see here, or may be excluded.

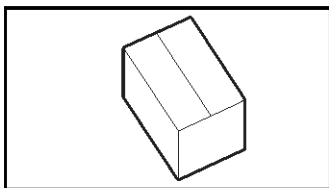
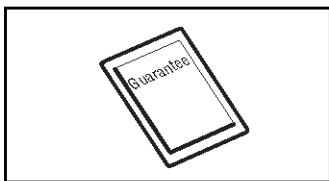

Important!

Please fill out the Global Warranty card and submit it to us in order that we can provide fast and efficient after-sales service. For malfunctions under **normal use**, this product will be repaired free of charge according to the warranty terms applicable for the country of use.

Please do not discard the original packaging box and cushioning material after installing the printer. They may be needed in future, if the printer needs to be shipped for repairs.

SECTION 2: INSTALLATION

2.1.2 PARTS IDENTIFICATION

IDENTIFYING THE MAIN PRINTER PARTS

Front View



Angled Front View

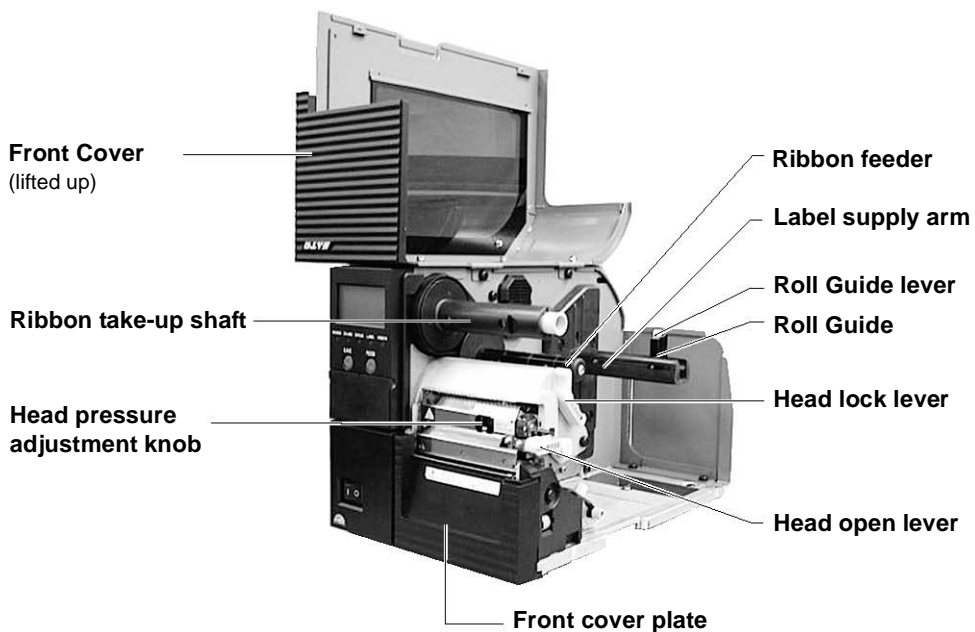

2.1.2 PARTS IDENTIFICATION (CONT'D)

IDENTIFYING THE MAIN PRINTER PARTS

Rear View



How to remove the cable cover

Position your body to face the rear of the printer. Press down on the release catch with your thumb, and slide the cable cover to your right.

Position your body to face the rear of the printer. Press down on the release catch with your thumb, and slide the cable cover to your right.

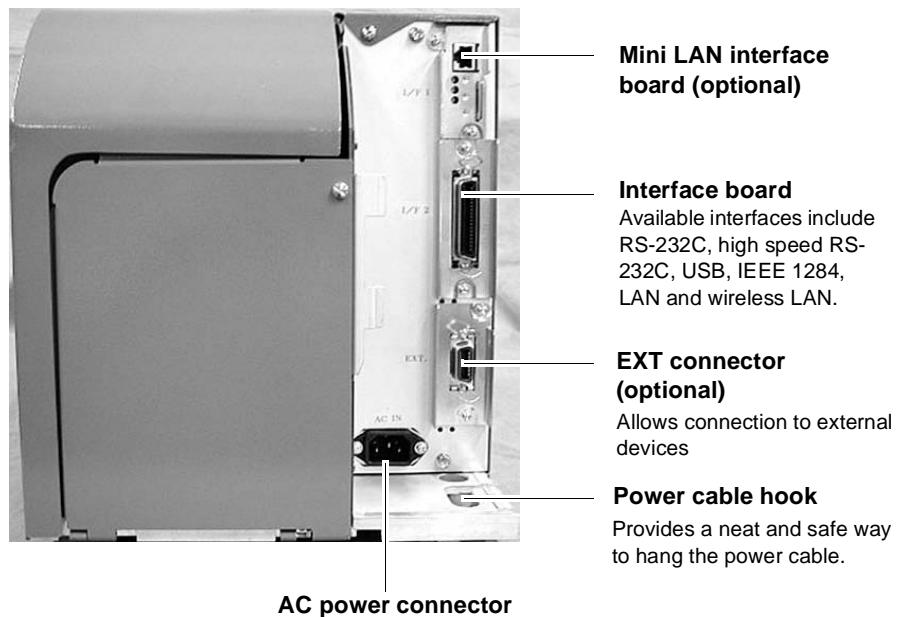

IDENTIFYING THE MAIN PRINTER PARTS

Side View
(Media assembly)

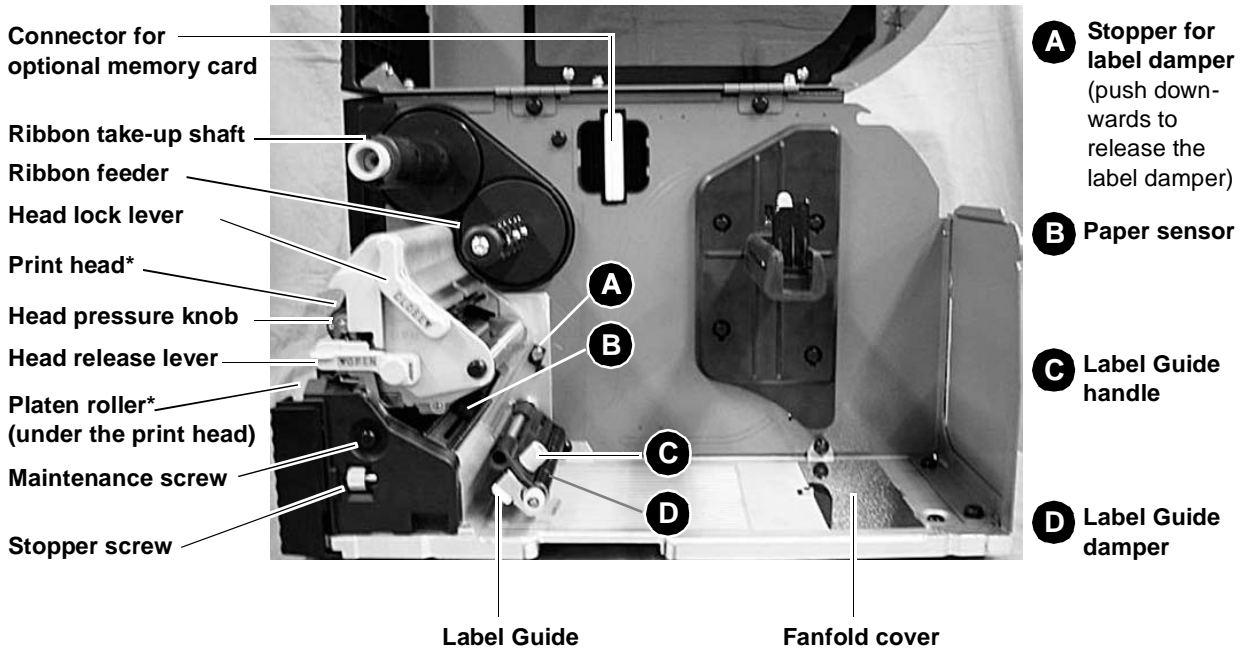

* Clean and maintain this part regularly

Angled Front View



2.1.2 PARTS IDENTIFICATION (CONT'D)

IDENTIFYING THE MAIN PRINTER PARTS

View of Front Panel

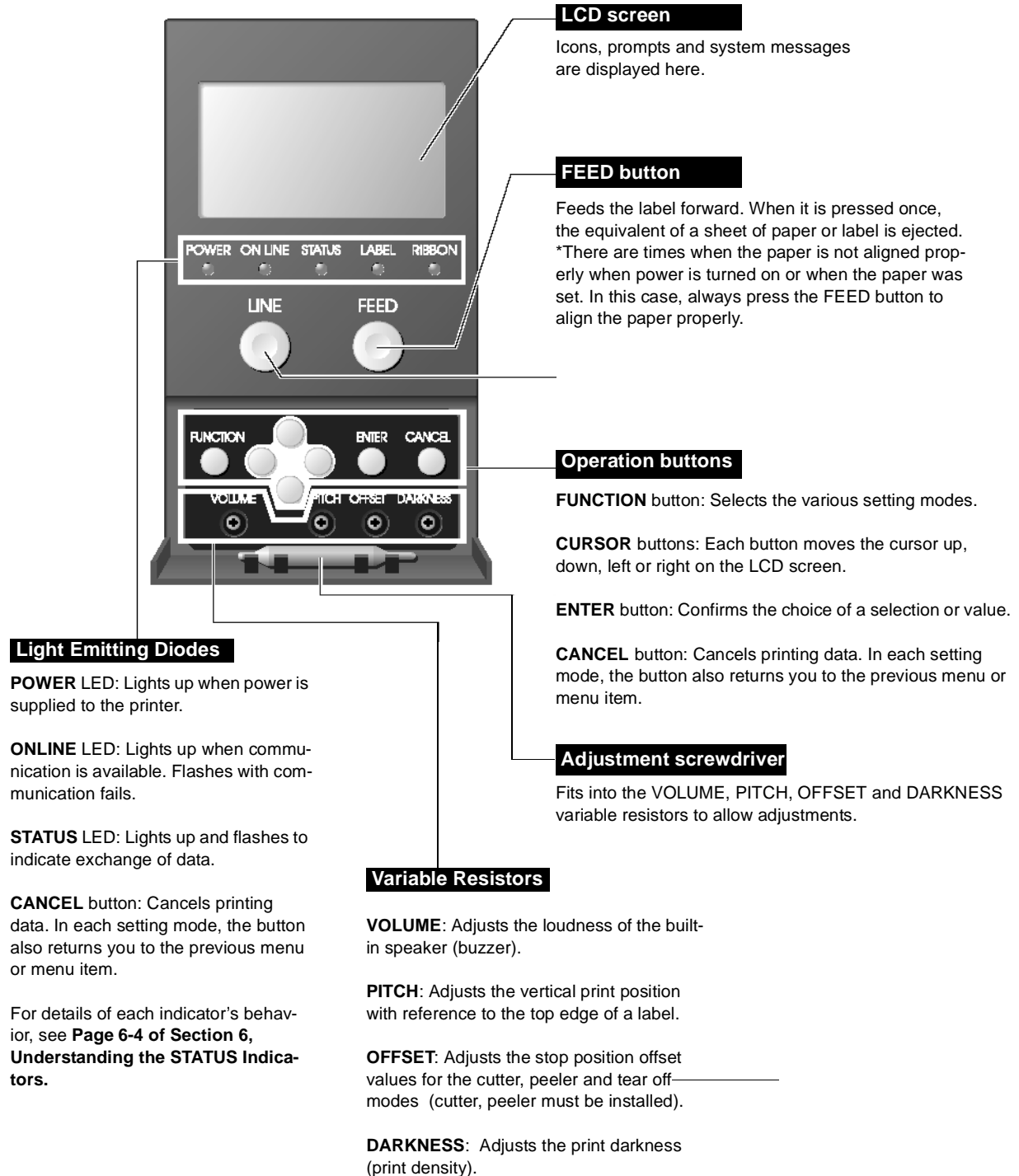

SECTION 2: INSTALLATION

2.2 LOADING THE CARBON RIBBON

1. Lift up the main cover. Make sure that the cover rests firmly on the top of the printer so that it will not fall forward and injure your hands.

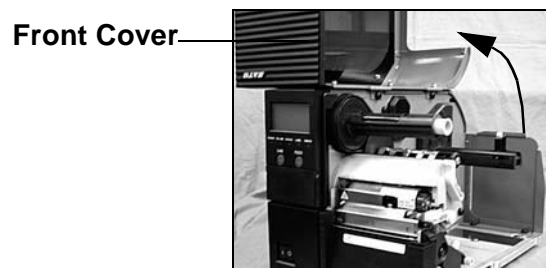

2. Release the purple head release lever by pushing it downwards. The print head assembly will be lifted up to allow label loading.

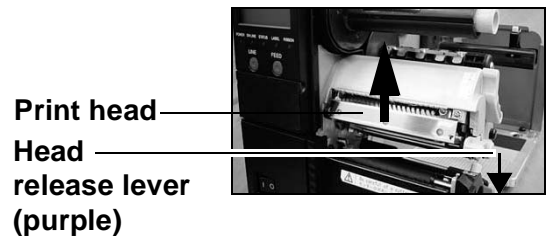

3. Insert the carbon ribbon in the ribbon feeder. Push it inwards all the way, with the ribbon winding in a clockwise direction around the print head, as shown. **Note: Use only genuine SATO carbon ribbons for maximum print quality and printer durability.**

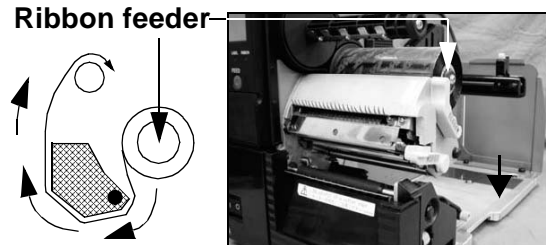

4. Check that the purple knob of the ribbon take-up shaft is **pushed inwards**, toward the back. If not, push it in.

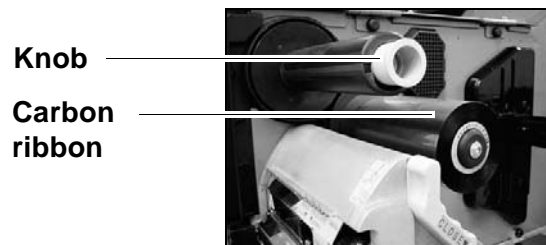

Caution

- Failure to ensure that the knob is pushed fully inwards before winding the new ribbon onto the shaft, will result in difficulties later when you wish to removing the used ribbon.

5. Pass the carbon ribbon under the print head to the ribbon take-up shaft. Affix the carbon ribbon directly to the grip sheet on the take-up shaft. Wind the ribbon several times in the direction of the arrow in the picture. Check from sideways that the carbon ribbon is installed according to Step 3 above.



6. Now remount the print head by pushing down on the head lock lever. The print head should lock into place firmly. You can now proceed to install the label media as described in the following sections.

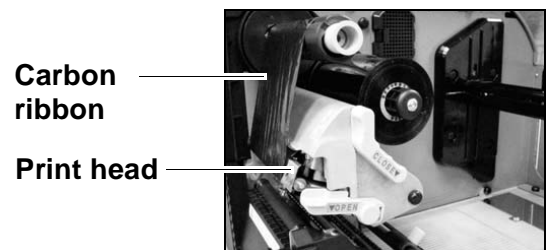

2.2 LOADING THE CARBON RIBBON (CONT'D)

2.2.1 Removing the Carbon Ribbon

Pull the purple knob on the ribbon take-up shaft outwards. Hold the carbon ribbon reel and pull it outwards. Some carbon powder may adhere to your hand during this process—if so, wash your hands to remove the powder.

Note:

Do not install a new carbon ribbon and then wind it over any **used ribbon** in the ribbon take-up shaft. That is, **always remove all used ribbon** from the ribbon take-up shaft (using the purple knob to release the used ribbon) before changing to a new ribbon.

Caution

- When replacing the carbon ribbon, bear in mind that the print head and its surrounding area remain hot. Keep your fingers away from these areas to prevent injury.
- Avoid touching even the edge of the print head with your bare hands.

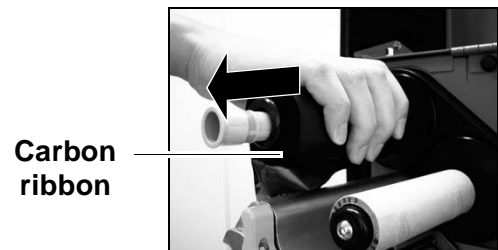
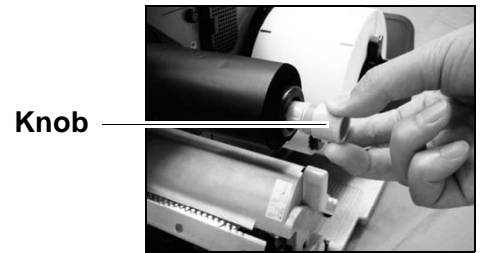

SECTION 2: INSTALLATION

2.2.2 OPTION: Using A Paper Tube to Wind Used Ribbon

Under certain circumstances, instead of using the GT printer's ribbon take-up shaft to collect used ribbon, users may prefer to use paper tubes to form a core for winding the used ribbon. This is a possible option that requires replacing the ribbon winding shaft with a different shaft (optional accessory). Once the optional shaft is installed, you can follow the steps below to use paper tubes for winding used ribbon.

1. Lift up the main cover and push the purple head release lever downwards. The print head assembly will be lifted up.

Replacement take-up shaft



2. Insert the carbon ribbon in the ribbon feeder and push it inwards all the way. Insert the paper tube into the new ribbon take-up shaft by pushing it inwards all the way.

Paper tube

Ribbon feeder

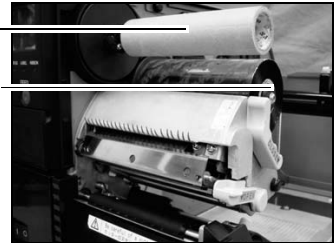

3. Pass the carbon ribbon from the ribbon feeder under the print head to the paper tube on the ribbon take-up shaft. Affix the ribbon to the paper tube with tape. Wind the ribbon several times around the tube.

Paper tube

Print head

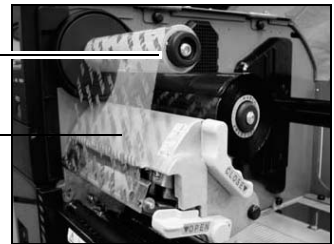

4. Check from sideways that the carbon ribbon is set as shown in the following picture.

Paper tube

Print head

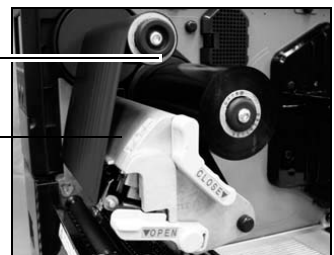

5. Now remount the print head by pushing down on the head lock lever. The print head should lock into place firmly. You can now proceed to load labels or other media as described in the following sections.

Label loaded

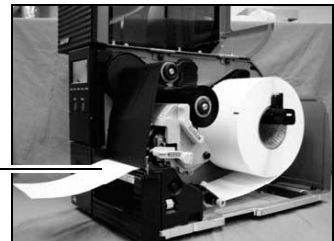

Caution

- When replacing ribbons, bear in mind that the print head and its surrounding area remain hot. Keep your fingers away from these areas to prevent injury.
- Avoid touching even the edge of the print head with your bare hands.

2.3 LOADING LABELS AND TAGS

This printer can print on **roll paper** and **fanfold paper**.

The method of setting paper is different with roll paper and fanfold paper.

This printer can be set to detect the I-mark on the paper to feed each label correctly.

Note:

For optimal print performance and durability, **please use SATO-certified label and ribbon supplies on this printer**. Using supplies not tested and approved for use by SATO can result in unnecessary wear and damage to vital parts of the printer, and may void the warranty.

Roll Paper Characteristics

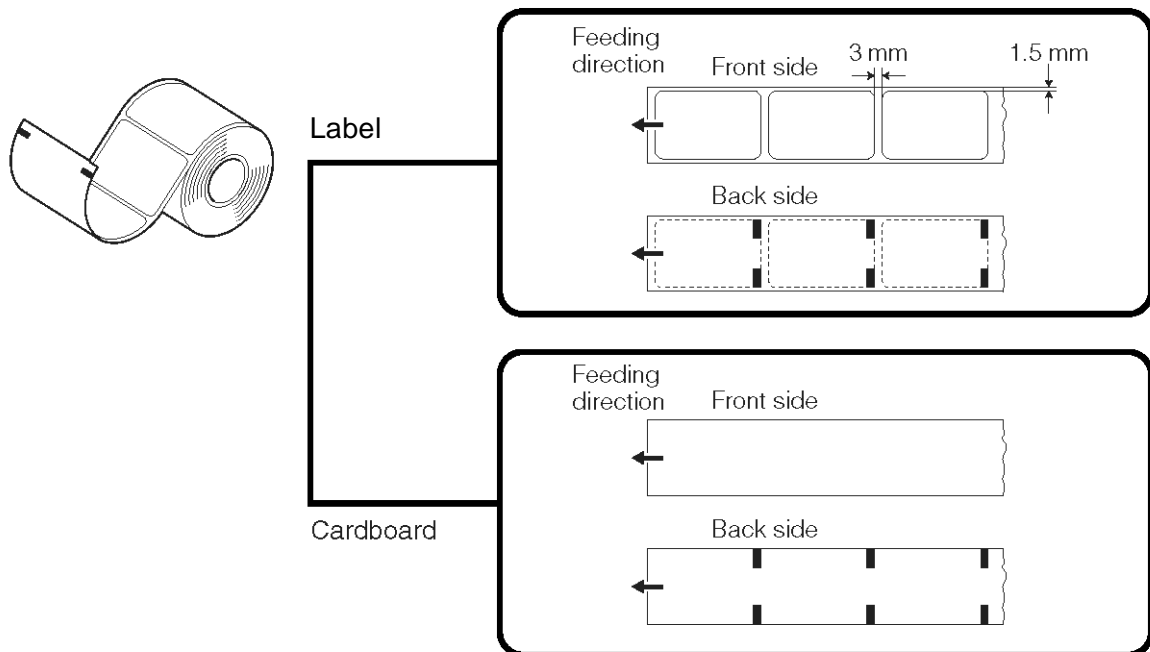

Fanfold Paper Characteristics

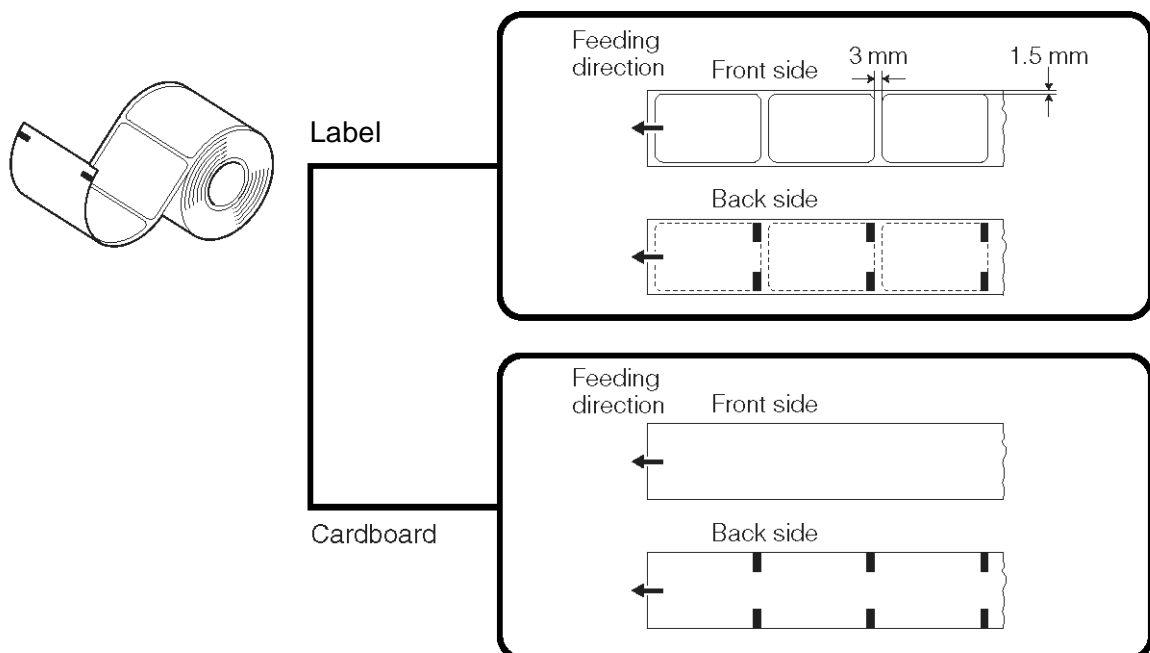

SECTION 2: INSTALLATION

2.3 LOADING LABELS AND TAGS (CONT'D)

2.3.1 Loading Roll Paper

1. Lift up the main cover. Make sure that the cover rests firmly on the top of the printer so that it will not fall forward and injure your hands.

Front Cover



2. Release the purple head release lever by pushing it downwards. The print head assembly will be lifted up to allow label loading.

Print head
Head
release lever
(purple)

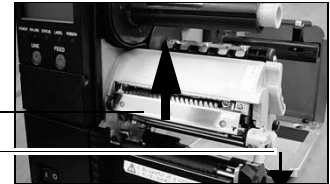

3. Push the spring-loaded purple Roll Guide lever sideways (to the right) to release the Roll Guide. Pull the Roll Guide outwards to the edge. Once the Roll Guide is moved to the edge, it will tilt backwards to allow a label roll to be inserted easily.

Roll Guide
Lever
Roll Guide

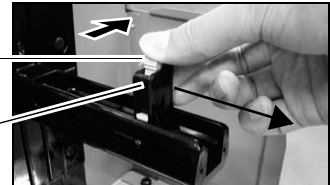

4. Insert the label roll and push the Roll Guide back into place. Make sure that the Roll Guide pushes snugly against the label roll to prevent label drift during printing.

Lift up the
Roll Guide.
Push the
purple lever to
the right and
move the Roll
Guide toward
the label roll.



Release the
Lever to lock
the Roll Guide
in place.

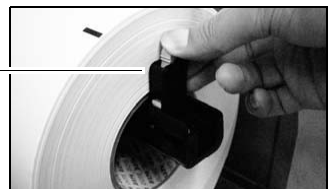

2.3 LOADING LABELS AND TAGS (CONT'D)

5. Pull out the purple label damper to release the label guide assembly. The label guide will drop downwards.

Pull the purple label damper.



6. Insert the paper into the label guide from a sideways angle, so that the paper passes under the label guide and paper sensor.

Label sensor

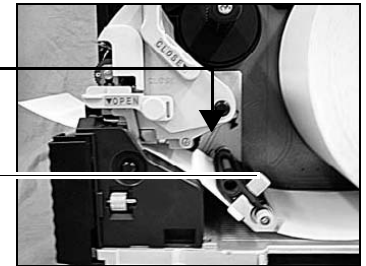

7. Adjust the label guide knob so that it lightly touches the edge of the label. Fasten the knob tightly.

Adjust the label guide knob

8. Now remount the print head by pushing down on the Head lock lever. The print head should lock into place firmly.

Print Head

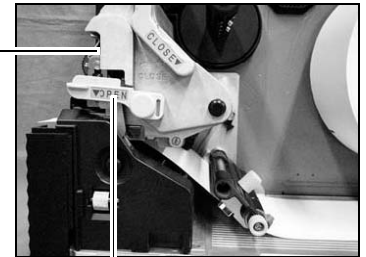

Head lock lever

9. If desired, close the main cover and do a test print to check that the label roll has been loaded properly. Be careful not to get your fingers caught at the bottom ledge when you are closing the main cover.

Caution

- When replacing paper, bear in mind that the print head and its surrounding area remain hot. Keep your fingers away from these areas to prevent injury.
- Avoid touching even the edge of the print head with your bare hands.

SECTION 2: INSTALLATION

2.3 LOADING LABELS AND TAGS (CONT'D)

Adjusting for the paper width

This printer is adjusted so that quality printing can be obtained without any adjustments. However, in certain situations, better results can be obtained if you adjust the “head pressure balance” to compensate for different widths of label paper used.

The head pressure balance knob adjusts the amount of pressure being applied along different sections along the length of the print head. For suggested settings of the pressure knob (1 to 5), see the table below:

SETTING	PAPER WIDTH
1	25~42 mm
2	42~59 mm
3	59~78 mm
4	78~95 mm
5	95~131mm

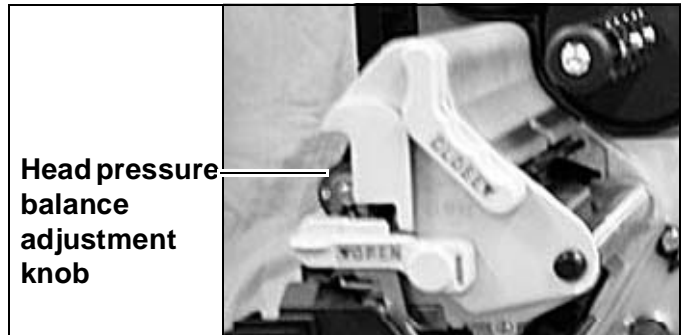

Note:

Adjustments are only necessary if print quality is not satisfactory. Otherwise, you do not need to vary the head pressure balance.

2.3 LOADING LABELS AND TAGS (CONT'D)

2.3.2 Loading Fanfold Paper

1. Lift up the main cover. Make sure that the cover rests firmly on the top of the printer so that it will not fall forward and injure your hands.

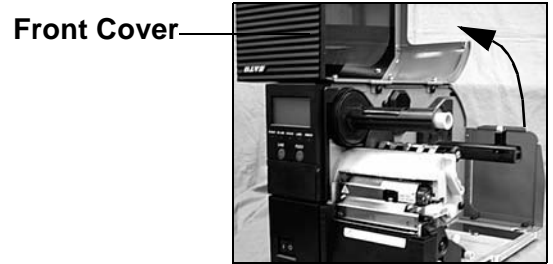

2. Remove the release screw that holds the rear cover in place. Keep the screw in a safe place for easy retrieval later.

Rear cover
release screw

Rear cover

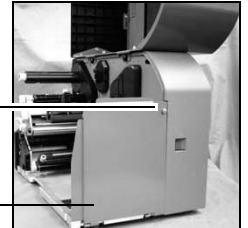

3. Tilt the rear cover until it rests on the table surface. On the surface of the cover you will see a factory-imprinted line that guides you in aligning the fanfold paper so that it feeds at the correct angle into the printer.

Rear cover

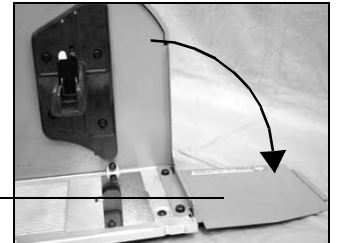

4. Load fanfold paper on top of the cover, up to 20 cm in height. Align the stack of fanfold paper to the factory-imprinted line.



5. Pass the paper from the tray over the Roll Paper Feeder. Adjust the Roll Guide so that it is in contact with the side of the paper. This will ensure that the paper moves forward at a consistent angle. (To move the Roll Guide forward or backward, first push the purple lever at the top of the guide sideways.)

Roll Guide

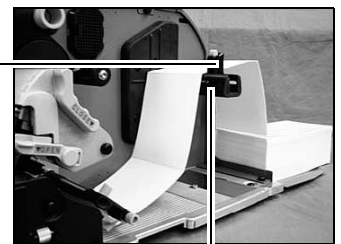

Roll Paper
Feeder

SECTION 2: INSTALLATION

2.3 LOADING LABELS AND TAGS (CONT'D)

6. Pull out the purple label damper to release the label guide assembly. The label guide will drop downwards.

Pull the purple label damper

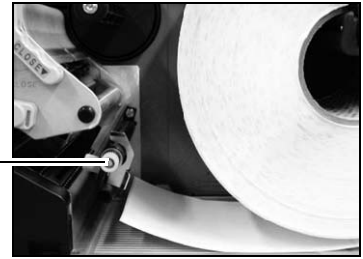

7. Insert the paper so that it passes under the label guide and paper sensor.

Label sensor

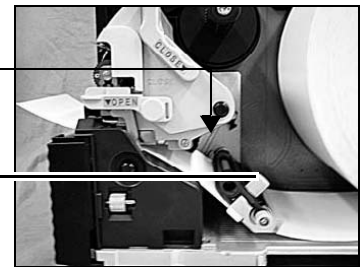

8. Adjust the label guide knob so that it lightly touches the edge of the label. Fasten the knob tightly.

Adjust the label guide knob

9. Now remount the print head by pushing down on the Head lock lever. The print head should lock into place firmly.

Print Head

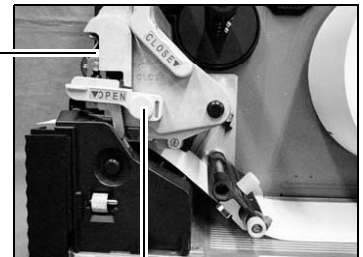

Head lock lever

10. If desired, close the main cover and do a test print to check that the label roll has been loaded properly. Be careful not to get your fingers caught at the bottom ledge when you are closing the main cover.

Note:

The procedure described above is recommended for loading a stack of fanfold paper that is 20 cm in height or higher.

For loading smaller reams of fanfold paper, use the rear cover as described in the previous section. Avoid loading stacks of paper from the rear if the height is greater than 20 cm.

Caution

- When replacing paper, bear in mind that the print head and its surrounding area remain hot. Keep your fingers away from these areas to prevent injury.
- Avoid touching even the edge of the print head with your bare hands.

2.3 LOADING LABELS AND TAGS (CONT'D)

2.3.3 Loading Fanfold Paper under the printer

1. Lift up the main cover. Make sure that the cover rests firmly on the top of the printer so that it will not fall forward and injure your hands.

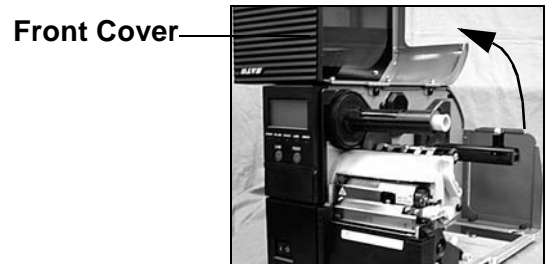

Note:

It is assumed that the printer is supported on stands to allow fanfold paper to be loaded from beneath the printer.

2. Release the purple head release lever by pushing it downwards. The print head assembly will be lifted up to allow label loading later.

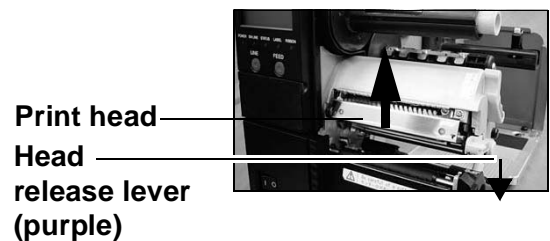

3. Unscrew the fanfold cover and remove it. Keep the cover and the screw in a safe place for future use.

Fanfold cover screw



Fanfold cover

Fanfold loading slot

4. Load the stack of fanfold paper straight through the fanfold loading slot.

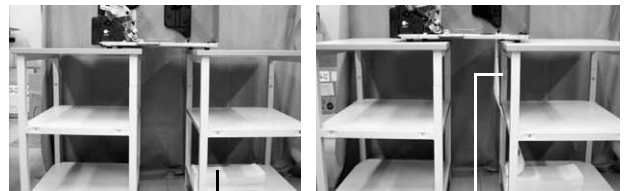

Fanfold paper before loading

Fanfold paper loaded into slot

5. Pass the paper through the fanfold loading slot and pull it into the chassis near the print head assembly.



Pull the paper into the chassis

Paper is now ready to load under print head

SECTION 2: INSTALLATION

6. Pull up the Label Damper by the purple knob in a counterclockwise direction until it locks into place vertically. If it is already in a vertical position proceed to the next step.

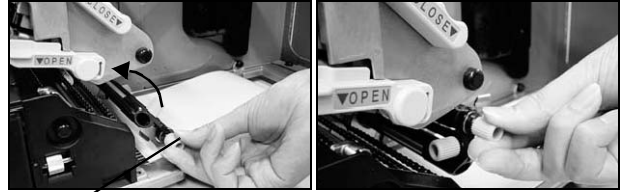

Label Guide Knob

Label Damper

7. Pass the paper under the label guide and paper sensor. Pull the label damper knob, and the label damper will drop down to press against the paper.



Label Guide

Label Damper

Caution

- When replacing paper, bear in mind that the print head and its surrounding area remain hot. Keep your fingers away from these areas to prevent injury.
- Avoid touching even the edge of the print head with your bare hands.

8. Loosen the label guide knob, and adjust the slide guide so that it lightly touches the edge of the paper. Now fasten the label guide knob tightly.

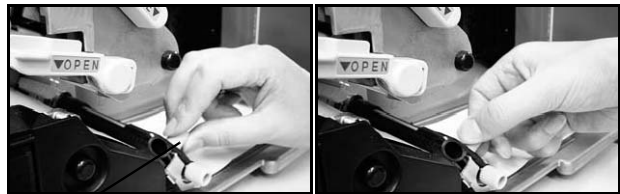

Label Guide Knob

9. Remount the print head by pushing down on the head lock lever. The print head should lock into place firmly.

10. If desired, close the main cover and do a test print to check that the label roll has been loaded properly. Be careful not to get your fingers caught at the bottom ledge when you are closing the main cover.

Print Head

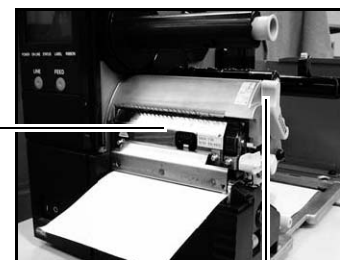

Head lock lever

Caution

- When replacing paper, bear in mind that the print head and its surrounding area remain hot. Keep your fingers away from these areas to prevent injury.

2.3 LOADING LABELS AND TAGS (CONT'D)

2.3.4 Adjusting the paper Sensor

Adjustment of the paper sensor is usually not necessary, but the procedure is described here.

1. Lift up the main cover. Make sure that the cover rests firmly on the top of the printer so that it will not fall forward and injure your hands.

Front Cover



2. The purple sensor unit is located just above the label damper assembly. Slide it outwards to adjust its position.

Paper sensor



3. You can continue to load media by following the steps in previous sections, or close the front cover.

Caution

- When closing the front cover, be careful not to injure your fingers due to a sudden release of the heavy cover.

SECTION 2: INSTALLATION

2.4 REPLACING THE PRINT HEAD

Before attempting to replace the print head, it is advisable to contact your local dealer or service center so that they can assist you in case of problems.

1. Make sure the printer has been turned off for at least 30 minutes so that the print head is not hot. Lift up the main cover.
2. Push the purple slide lever outwards, in the direction shown here. The print head will be released.

Caution

- Do not touch the print head's heating elements. If you do so inadvertently, use the cleaning pen (supplied) to clean the area thoroughly. For more details, see Section 4, Cleaning and Maintenance.



4. Pull the print head outwards and disconnect the two connectors attached to it.



5. Attach the connectors to the new print head.

6. There are two hooks on the left and right sides of the print head. Insert the left-side hook into the printer first. Mount the hook under the cylinder marked with the ◀ arrow symbol.



7. Now mount the right-side hook of the print head under the cylinder marked with the ▼ arrow symbol. The print head should snap into place firmly. If not, release the print head and try again from Step 6 above.



2.5 TURNING THE PRINTER ON/OFF

1. After removing the cable cover at the rear of the printer (See Page 2-7), you can proceed to install the interface and power cables as shown.

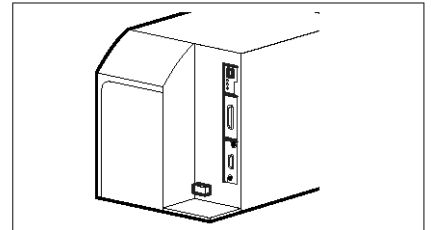

2. To limit movement of the cables, you can optionally channel the cables through the cable hook area at the base of the printer.

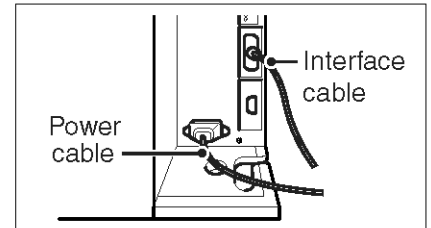

3. Insert the power cable first to the printer, then connect the other end to the power outlet. If necessary, use an adapter to match the prongs on the power cable to the sockets in the AC outlet.

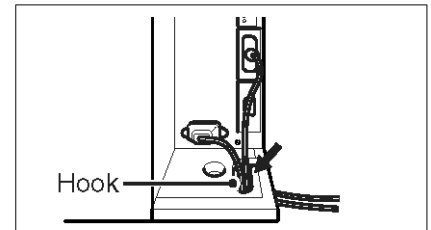

Caution

- Always use a grounded power cable to protect against electrical leakage and electrical shocks.

4. To turn the printer ON, press the power switch to the “I” side. When the printer is successfully turned on, the LCD screen will display something similar to that shown here.

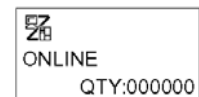

Caution

- To prevent electric shocks, make sure your hands are dry when you operate the power switch, or when you pull out or insert power cables and switches.



5. If the printer does not respond, refer to the **Troubleshooting** section of this manual.
6. Before turning the printer off, perform the following steps:
 - Take the printer offline by pressing the Line button. The LCD shows the following:
 - Press the Feed button to eject any label at the front of the printer.
 - Lightly pull the paper diagonally downward to tear off the label.
7. To turn the printer off, press the power switch to the “O” side.

SECTION 2: INSTALLATION

This page is intentionally left blank

3

CONFIGURATION AND OPERATION

Before using the printer, it is best to read this manual thoroughly first. Otherwise, you may disturb default settings around which the instructional procedures in this manual are based upon.

3.1 OPERATING MODES

The operating status of this printer can be set to one of five modes:

- 1) Online mode
- 2) Offline mode
- 3) Printer Setting modes:
User Mode, Interface Mode, Cartridge Mode, SEMBL Mode, Advanced Mode, Hex Dump Mode, Test Print Mode)
- 4) Error mode
- 5) Test Print mode

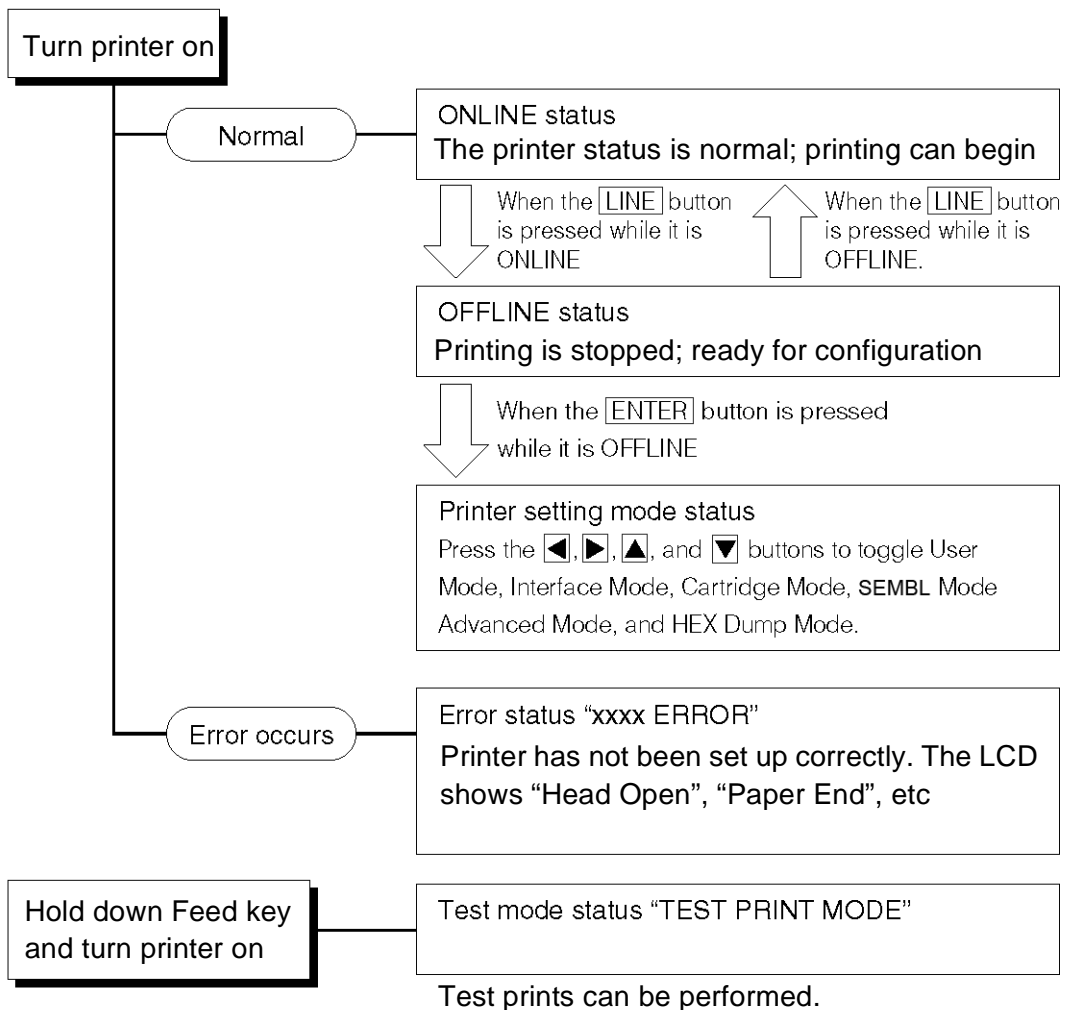

3.2 THE OPERATION PANEL

Overview of the Operation Panel



Status Icon display area

Up to five icons can appear here to indicate the current printer status. The same area can also display two lines of alphanumeric text instead.

Two-line Message display area

Other icons, or up to two lines of alphanumeric messages, can be displayed here.

In total, up to four lines of text can be displayed on the whole screen.

How To Adjust Screen Contrast

In ONLINE or SEMBL mode, press the left/right arrow buttons repeatedly to adjust the contrast.



Contrast settings are reset whenever you reset the printer to default settings.

Overview of the Display for Printer Setting

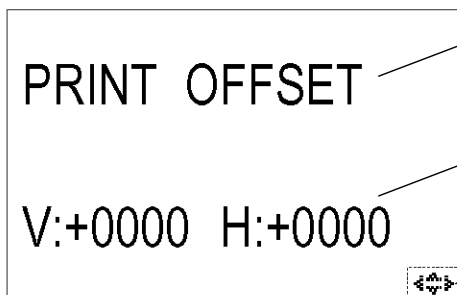

Description of Setting

The current function being set can be described in up to two lines of text.

Value to be Set

Available setting values or options are displayed here in up to two lines.

Usable Navigation Buttons







Shows only those arrow keys that are valid for changing the current setting. The arrow keys are a combination of ,

, , and .







3.3 SCREEN ICONS AND THEIR MEANING

【Mode display】









〈List of icons〉

No.	Icon	Description	Display position
1		Displayed when the printer is online.	Icon 1
2		Displayed when the printer is offline.	Icon 1
3		Displayed when the printer is in Test Printing Mode and Dump Printing Mode.	Icon 1
4		Displayed when the printer is in SEMBL Mode.	Icon 1
5		Displayed when the printer is in Download Mode.	Icon 1
6		Displayed when the printer is in Upload Mode.	Icon 1
7		Displayed when the printer is in Cartridge Mode.	Icon 1







【Mode selection screen】

No.	Icon	Description	Display position
1		Switches the printer to Normal Mode.	—
2		Switches the printer to User Mode.	—
3		Switches the printer to Interface Mode.	—
4		Switches the printer to Cartridge Mode.	—
5		Switches the printer to SEMBL Mode.	—
6		Switches the printer to Advanced Mode.	—
7		Switches the printer to Dump Printing Mode.	—





【Error-related】

No.	Icon	Description	Display position
1		Displayed when label end is detected.	Icon 1
2		Displayed when ribbon end is detected.	Icon 1
3		Displayed when sensor error is detected.	Icon 1
4		Displayed when head open is detected.	Icon 1
5		Displayed when head disconnection is detected.	Icon 1
6		Displayed when a communication error is detected.	Icon 1
7		Displayed when a receive buffer error is detected.	Icon 1
8		Displayed when a item No. error or BCC error is detected.	Icon 1
9		Displayed when a cutter error is detected.	Icon 1

3.3 SCREEN ICONS AND THEIR MEANING (CONT'D)

No.	Icon	Description	Display position
10		Displayed when the upper blade of the cutter is open.	Icon 1
11		Displayed when a normal access to memory cartridge is denied.	Icon 1
12		Displayed when writing in the main ROM has failed. Also displayed when a Kanji ROM error is detected.	Icon 1
13		Shown when information cannot be written in RFID tag.	Icon 1
14		Displayed when the internal winding unit is full of paper.	Icon 1
15		Displayed when a printer error other than the above is detected.	Icon 1
16		Error number corresponding to each error is displayed.	Icon 2

[Warning-related]

No.	Icon	Description	Display position
1		Displayed when ribbon near end is detected.	Icon 3 to 5
2		Displayed when label near end is detected.	Icon 3 to 5
3		Displayed when command error is detected.	Icon 3 to 5
4		Displayed when receive buffer near full is detected.	Icon 3 to 5
5		Displayed when the head is disconnected.	Icon 3 to 5

3.4 ONLINE AND OFFLINE MODES

3.4.1 Online Mode

Pressing the **LINE** button causes the printer to go ONLINE or OFFLINE alternately.

When the printer is ONLINE, the following activities will be possible:

- The printer is ready to receive print data from the computer or other connected devices
- The printer is ready to start printing



3.4.2 Offline Mode

When the printer is ONLINE, pressing the **LINE** button once will cause the printer to go OFFLINE.

When the printer is OFFLINE, the activities for ONLINE mode are no longer possible, but the following activities will be possible:

- The printer can eject labels when you press the **FEED** button.
- The printer can be switched to other modes when you press the **ENTER** button.
- Any printing job can be stopped once the printer is brought OFFLINE
- Any printing job can be cancelled once the **CANCEL** button is pressed in OFFLINE mode. The menu for canceling the print job then appears.
- Received data that is stored in the buffer memory can be saved into a memory cartridge, if the **LINE** button is pressed and held down for at least five seconds in OFFLINE mode. The following screens will appear.

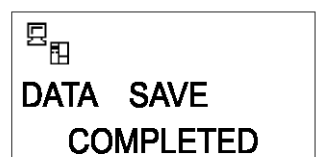
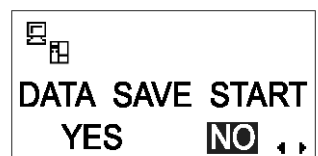
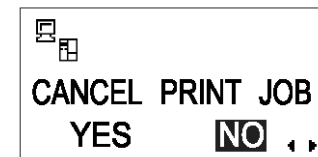
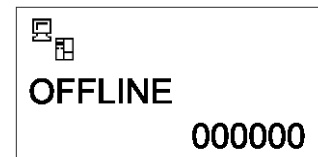

3.5 USER MODE

The following settings are available in User Mode:

- OFFSET VOLUME (volume of the built-in buzzer/speaker)
- PRINT SPEED (print speed setting)
- PRINT DARKNESS (print density setting)
- PRINT OFFSET (print position correction setting)
- ZERO SLASH (zero slash changeover setting)
- JIS CODE (JIS code changeover setting)
- KANJI FONT (Kanji font changeover setting)
- CHARACTER PITCH (proportional pitch setting)

3.5.1 Entering User Mode

1. Press the **LINE** button to take the printer OFFLINE.
2. Pull down the cover of the Operation Panel and press **ENTER**. The ONLINE MODE screen appears.
3. Press the ◀ ▶ ▲ ▼ arrow buttons until you see “USER MODE”, then press **ENTER**.

Note:

The bottom right-hand corner of the screen sometimes displays one to four arrow symbols (see circled symbols on the right). Each arrow symbol represents the corresponding arrow button on the operation panel which is valid for the changing the current screen or its settings.

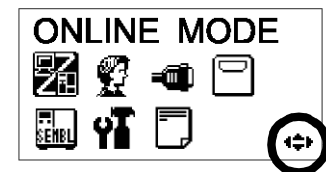
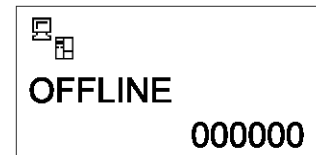

4. When the first User Mode screen appears, you will need the yellow screwdriver (fastened to the Operation Panel flap), to adjust the OFFSET VOLUME, PITCH, OFFSET and DARKNESS potentiometers. See **Section 3.5.2 Setting Print Speed**.
5. Subsequently, pressing the **ENTER** button brings you to screens for setting PRINT SPEED, PRINT DARKNESS and OFFSET. At any time, pressing **CANCEL** takes you back one screen. Pressing the **FUNCTION** button returns you immediately to the main User Mode screen.

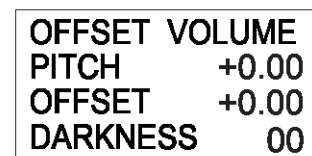

3.5.2 Setting Buzzer Volume, Print Pitch, Print Offset, Print Darkness

The volume level of the built-in speaker buzzer can be adjusted at the first menu of the User Mode. Use the yellow screwdriver to adjust the VOLUME potentiometer below the LCD. The value on the screen changes as you turn the screwdriver clockwise or counter-clockwise.



Next, you can use the screwdriver to rotate the potentiometer for the **Print Pitch**. This setting adjusts where printing begins vertically, relative to the bottom edge (nearest the print head) of each label. The maximum value allowed is 3.75 mm.

Adjusting the **OFFSET** potentiometer adjusts the tear-off stop position for use with a cutter, peeler.

Finally, adjusting the Print Darkness potentiometer adjusts the print darkness.

When all the settings are satisfactory, press the **ENTER** button to proceed to set other parameters in the User Mode.

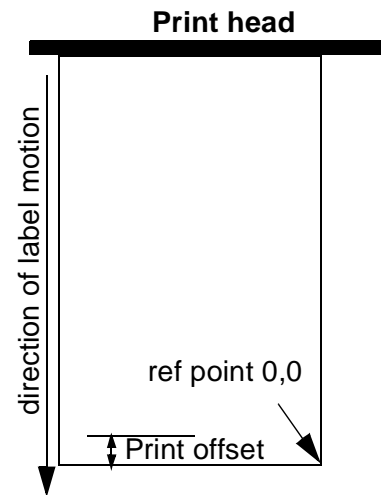

3.5.2 Setting Print Speed

After setting OFFSET VOLUME, PITCH, OFFSET and DARKNESS, pressing **ENTER** takes you to the Print Speed setting. This setting can be used to achieve a high print speed that does not compromise print quality.

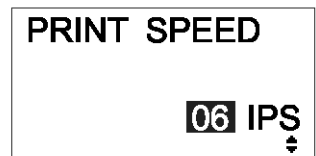

Press the ▲▼ buttons to change the setting. Press the **ENTER** button to confirm a setting and proceed to the next screen.

If quality printing cannot be obtained due to the quality of the paper or the printing contents, lower the speed accordingly. On the GT408 and GT412, the print speed can be set in 11 steps. On the GT424, the print speed can be set in five steps in GT424. The table below shows the factory default print speed for different print resolutions.

Print head resolution: default print speed setting	Available print speed settings (lower numbers mean slower print speeds)
203 dpi: default 06 inches/sec	02, 03, 04, 05, 06, 07, 08, 09, 10, 11, 12 inches/sec
305 dpi: default 06 inches/sec	02, 03, 04, 05, 06, 07, 08, 09, 10, 11, 12 inches/sec
609 dpi: default 03 inches/sec	02, 03, 04, 05, 06 inches/sec

3.5.3 Setting Print Darkness

After setting Print Speed, the next screen allows you to set the Print Darkness—the darkness of the print on paper.

This setting can be set from 1 (lightest) to 5 (darkest). The default setting is 3.



Press the ◀/▶ buttons to change the setting. Press the **ENTER** button to confirm a setting and proceed to the next screen.

3.5.4 Setting Print Offset

After setting Print Darkness, the next screen allows you to set the Print Position Offset—which refers to the vertical and horizontal shifting of the entire print area, relative to the start position of printing (V=0, H=0), defined by default to be the bottom right hand corner of the label.

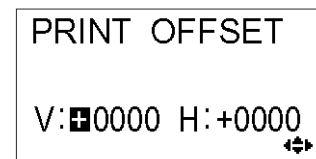

Use the ◀/▶ buttons to select the V or H setting, and the ▲/▼ buttons to change a highlighted setting. Press the **ENTER** button to confirm a setting and proceed to the next screen.

The V setting is for the Vertical print offset. A positive (+) offset means the printing is shifted towards the print head; a negative (-) offset means shifting away from the print head. If the Print Pitch setting has been used to offset the vertical start position, then all Vertical offset adjustments are made relative to that start position.

The H setting is for the Horizontal print offset. The + or - prefix determines whether the offset is to the left or to the right of the reference point.

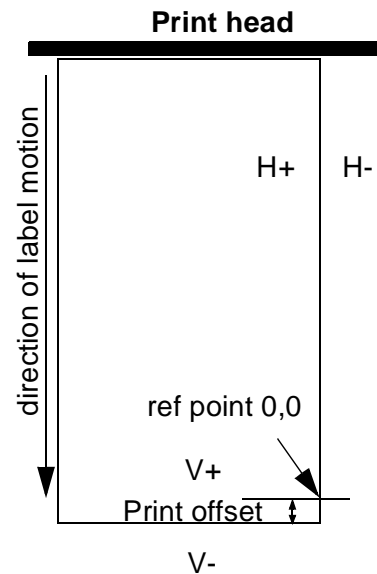

Printer	Valid H and V settings (in dots)
GT408	V: +/- 000 to 1424 dots, H: +/- 000 to 832 dots
GT412	V: +/- 000 to 2136 dots, H: +/- 000 to 1248 dots
GT424	V: +/- 000 to 4272 dots, H: +/- 000 to 2496 dots

After setting the Vertical and Horizontal OFFSET, press **ENTER** to proceed to the next setting.

3.5.5 Setting Zero Slash Changeover

You can use this setting to determine whether zeroes are printed with a slash across them or not. The zero slash (excluding Kanji) can be set to either "0" or "Ø".

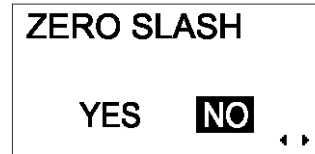

Use the ◀/▶ buttons to select YES or NO. 'YES' means zeroes will be printed with a diagonal slash across them. 'NO' means otherwise. The default value is 'NO'.

Press ENTER to select the desired option and proceed to the next setting.

3.5.6 Setting JIS Kanji Code Changeover*

* option is only valid for printing in Japanese

The printer can be set to use either JIS code or Shift JIS code.

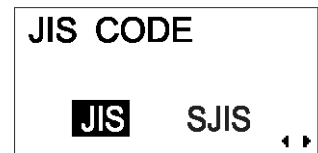

Use the ◀/▶ buttons to select JIS or SJIS. The default value is JIS code.

Press ENTER to confirm your selection and proceed to the next setting.

3.5.7 Setting Kanji Font Style*

* option is only valid for printing in Japanese

The Kanji font style can be set to either "GOTHIC" or "MINCHO".

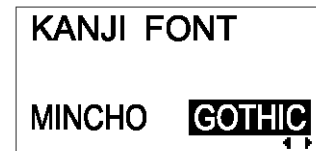

Use the ◀/▶ buttons to select GOTHIC or MINCHO. The default value is GOTHIC.

Press ENTER to confirm your selection and proceed to the next setting.

3.5.7 Setting Proportional Pitch

This setting determines whether the space surrounding each text character is of a fixed width, or whether that space is to be varied to be visually more pleasant.

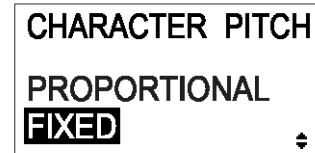

Use the ▲▼ buttons to select either PROPORTIONAL or FIXED. The default value is FIXED.

Press ENTER to confirm your selection and return to the main User Mode screen. Press the **FUNCTION** or **CANCEL** key to exit the User Mode setting.

Note:

The subject fonts are from x21 to x24





3.6 INTERFACE MODE

In this mode, you can set various parameters governing the use of interface cards. Due to the wide range of interface cards available, only the default interface configuration settings are covered in this section. A flowchart overview of advanced settings for all the optional interface cards is included at the end of this chapter, and a detailed discussion of advanced settings can be found in the GT Series Service Manual available upon request.

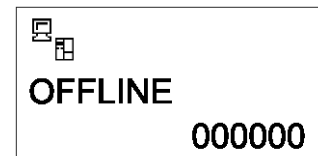
3.6.1 Entering Interface Mode

1. Press the **LINE** button to take the printer OFFLINE.
2. Pull down the cover of the Operation Panel and press **ENTER**. The ONLINE MODE screen appears.



3. Press the     arrow buttons until you see "INTERFACE MODE", then press **ENTER** to perform the first setting. At any time within this mode, pressing **CANCEL** takes you back one screen. Pressing the **FUNCTION** button returns you immediately to the main Interface Mode screen.





3.6.2 Enabling Interface Card Configuration

The first setting in the Interface Mode lets you select whether you wish to configure an interface card for bi-directional communication.

If YES is selected, the next screen lets you select an interface card to configure.

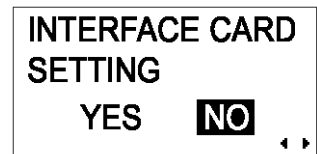
If NO is selected, the next screen lets you choose the correct port for receiving print data. See **Section 3.6.4 Selecting The Data Input Port**.



Press the   buttons to select either YES or NO.

Press the **ENTER** button to confirm the setting and proceed to the next screen (see either **Section 3.6.3** or **3.6.4** on page 3-12).

3.6.3 Assigning An Interface Card For Printing

This setting lets you select which installed interface card is to be used for bi-directional communication/printing. The other card is then presumed to be a mini LAN card, which is intended for transmitting printer status information to a LAN.



The card selected by default for bidirectional communication is the one that is not a mini LAN card. Card2 is assumed to be a mini LAN card.

Press the ◀/▶ buttons to select either CARD1 or CARD2.
Press the **ENTER** button to confirm a setting and proceed to the next screen.

3.6.4 Selecting The Data Input Port

Use this setting to define which installed interface card is to be used as the port for receiving print data. The default value is CARD1 (which is the non mini LAN card).

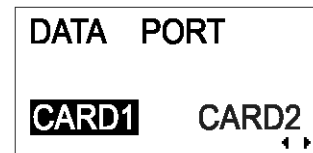

Press the ◀/▶ buttons to select either CARD1 or CARD2.
Press the **ENTER** button to confirm a setting and proceed to the next screen.

Note:

If you set the data input port to be CARD2 but print data is received at CARD1, printing will not occur. The reverse also holds true.

3.6.5 Enabling or Disabling The Status Return Port

Use this setting to enable or disable the status return port. The interface card which is not being used as the data input port (see **Section 3.6.4** above) is the status return port. The default value is ENABLE.

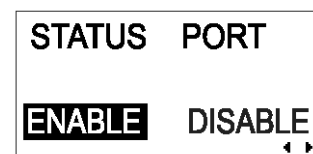

Press the ◀/▶ buttons to select either ENABLE or DISABLE.
Press the **ENTER** button to confirm a setting and return to the main screen of the Interface Mode.

3.7 CARTRIDGE MODE

In this mode you can manage the optional memory cartridge that can be installed to provide increased storage capacity for text and graphics.

3.7.1 Entering Cartridge Mode

1. Press the **LINE** button to take the printer OFFLINE.
2. Pull down the cover of the Operation Panel and press **ENTER**. The ONLINE MODE screen appears.

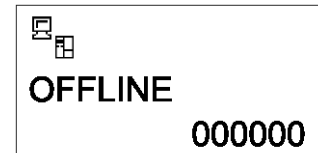

3. Press the arrow buttons until you see "CARTRIDGE MODE", then press **ENTER** to perform the first setting. At any time within this mode, pressing **CANCEL** takes you back one screen. Pressing the **FUNCTION** button returns you immediately to the main Cartridge Mode screen.



3.7.2 Cartridge Formatting Option

Use this function to clear the memory cartridge of all contents.

Press the buttons to select either YES or NO. Selecting NO returns you to the main Cartridge Mode screen. Selecting YES causes the FORMAT START screen to appear (see the next section).

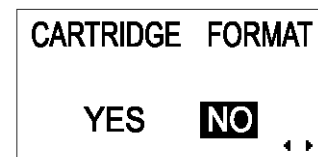

Press the **ENTER** button to confirm the setting and proceed to the next screen.

3.7.3 Start Cartridge Formatting

If you selected YES at CARTRIDGE FORMAT screen, this screen lets you start or cancel the cartridge initialization procedure.

Press the buttons to select either YES or NO. Selecting NO returns you to the CARTRIDGE FORMAT screen. Selecting YES begins the cartridge initialization (see **page 3-14**)

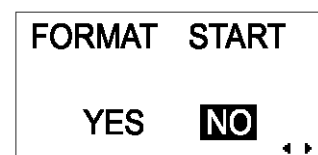

Press the **ENTER** button to confirm the setting and proceed to the next screen.

3.7.4 Cartridge Formatting Progress

If you selected YES at the FORMAT START screen, this next screen lets you monitor the progress of the formatting.

When formatting is complete, the next screen appears.
Press the **ENTER** button to return to the main CARTRIDGE MODE screen.

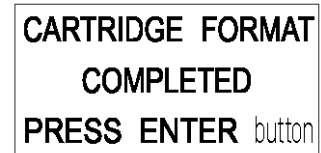
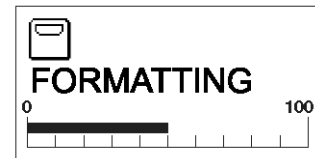

3.8 SEMBL MODE

SEMBL stands for SATO EMBEDDED BASIC Language. This feature allows software programs written in standard BASIC language to be loaded into the printer and executed without any further connection to a computer. For more details consult a qualified SATO sales person.

In this mode you can control the operation of BASIC programs loaded into memory.

3.8.1 Entering SEMBL Mode

1. Press the **LINE** button to take the printer OFFLINE.
2. Pull down the cover of the Operation Panel and press **ENTER**. The ONLINE MODE screen appears.

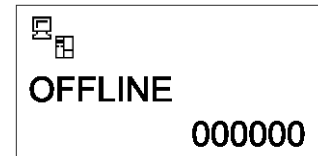

3. Press the ◀ ▶ ▲ ▼ arrow buttons until you see "SEMBL MODE", then press **ENTER** to perform the first setting. At any time within this mode, pressing **CANCEL** takes you back one screen. Pressing the **FUNCTION** button returns you immediately to the main SEMBL Mode screen.

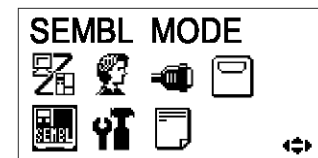

3.8.2 Selecting The Start Program

This first setting in SEMBL MODE allows you to specify which software program in the printer's memory will be executed when SEMBL Mode is started.

Use the ▲ ▼ buttons to select either NONE or to select from a list of BASIC programs already loaded in memory.

Press ENTER to confirm your selection and proceed to the next setting. Press the **FUNCTION** or **CANCEL** key to exit the SEMBL Mode setting.

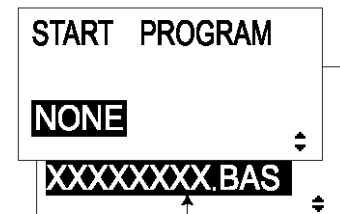

Name of program in memory

3.8.3 The SEMBL Status Screen

This screen indicates the number of labels that remain to be processed by the program.

Press **ENTER** to return to the main SEMBL Mode screen.

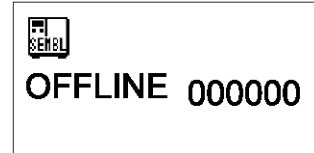
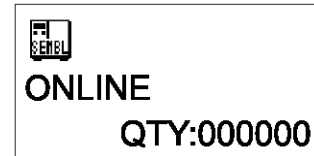





3.9 ADVANCED MODE

Advanced Mode lets you configure the more advanced features of the printer hardware.

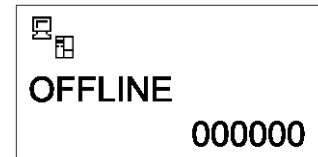
3.9.1 Entering Advanced Mode

1. Press the **LINE** button to take the printer OFFLINE.
2. Pull down the cover of the Operation Panel and press **ENTER**. The ONLINE MODE screen appears.





3. Press the     arrow buttons until you see “ADVANCED MODE”, then press **ENTER** to perform the first setting. At any time in this mode, you can press the **FUNCTION** or **CANCEL** key to return to the Advanced Mode screen.

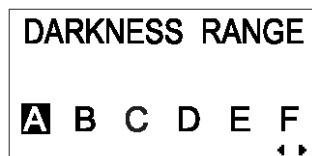

3.9.2 Selecting The Print Density

This first setting in ADVANCED MODE lets you set how dark the print quality is. Available options are from 'A' to 'F', with 'F' being the darkest density. The default value is 'A'.





Adjustment of this setting is usually unnecessary. To adjust the print density, use the   buttons to select an option.

Press **ENTER** to confirm your selection and proceed to the next setting.

3.9.3 Setting the Automatic Detection of Optional Units

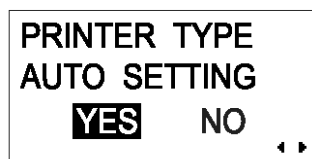
The next setting, PRINTER TYPE AUTO SETTING, determines whether the printer automatically detects the installation of optional peripherals such as a peeler or cutter. If detected, an optional peripheral will be used without needing further user configuration.



Use the   buttons to select either YES or NO. The default option is YES (auto detect). Choose NO if optional devices are installed, but you have wish to override the automatic settings.

Press **ENTER** to proceed to the next setting.

3.9.4 Choosing Continuous or Tear Off Operation

With this setting, you can choose between continuous paper feed or Tear Off operation. If a cutter or peeler has been installed correctly, you will also see the DISPENSER and CUTTER settings. If the printer supports linerless labels, you will also see a LINERLESS option.



Press the ▲▼ buttons to select any one of the options. The default setting is CONTINUOUS.

Press the **ENTER** button to confirm the setting and proceed to the next screen.

3.9.5 Backfeed Operation Settings

The printer can be set to apply or not apply a backfeed to the label *before* or *after* printing each label.



Press the ▲▼ buttons to choose from AFTER, BEFORE or NONE. The default setting is AFTER.

Press the **ENTER** button to confirm the setting and proceed to the next screen.

3.9.6 Configuring the Internal Winding Unit

The printer can be set to apply or not apply a backfeed to the label *before* or *after* printing each label.

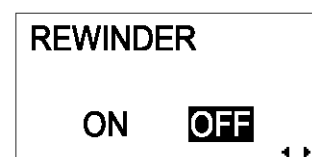

Press the ◀/▶ buttons to choose from AFTER, BEFORE or NONE. The default setting is AFTER.

Press the **ENTER** button to confirm the setting and proceed to the next screen.

3.9.7 Setting the Print Mode

The printer can be switched to operate in Thermal Transfer or Direct Thermal mode with this setting.

Press the ◀/▶ buttons to select the TRANSFER or DIRECT option. The default value is TRANSFER.

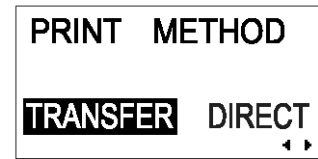

Press the **ENTER** button to confirm the setting and proceed to the next screen.

3.9.8 Configuring the Paper Sensor

The printer can be switched to operate in Thermal Transfer or Direct Thermal mode with this setting.

Press the ◀/▶ buttons to select the TRANSFER or DIRECT option. The default value is TRANSFER.

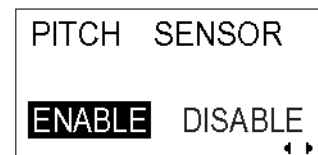

Press the **ENTER** button to confirm the setting and proceed to the next screen.

3.9.9 Configuring the Paper Sensor Type

This setting specifies which paper sensor is to be used: Gap sensor (penetration sensor) and I-Mark sensor.

Press the ◀/▶ buttons to select between I-Mark or GAP settings. The default value is I-MARK.



Press the **ENTER** button to confirm the setting and proceed to the next screen.

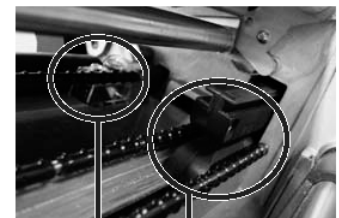

I-MARK2 (reflection sensor 2) I-MARK1 (reflection sensor 1)
GAP (penetration sensor)

3.9.10 Turning Head Check Function ON/OFF

The printer can be set to perform a check of the print head when printing each label.

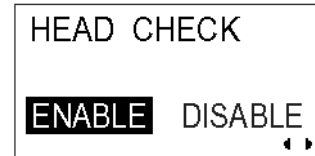

Press the ◀/▶ buttons to select the ENABLE or DISABLE option. The default value is ENABLE.

Press the **ENTER** button to confirm the setting and proceed to the next screen.

3.9.11 Choosing the Type of Head Check

If Head Check has been enabled, you will see this screen. Here, you can specify the print head checking to be performed unconditionally, or only when barcodes are being printed.

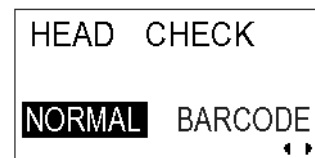

Press the ◀/▶ buttons to select the NORMAL or BARCODE option. The default option is NORMAL.

Press the **ENTER** button to confirm the setting and proceed to the next screen.

About the Head Check function

- The head check function detects the integrity of the heating elements in the thermal print head. However, malfunctions cannot be detected instantaneously—a few printed labels may start showing printing defects before the printer warns of a print head error.
- After detection of a print head error, use a scanner to check all affected labels.
- When a head check error occurs during normal printing (barcodes, text and graphics), press and hold down the **FEED** button for five seconds. At the next screen, select NORMAL and then press and hold down the **LINE** and **FEED** buttons for five seconds to cause printing to resume. If the head check error occurs again, set the type of head check to BARCODE and see if printing can be resumed normally.
- Although restricting the head check type to BARCODE allows you to continue printing, you should only do so in order to complete an urgent print job. Check the printed labels to make sure the output is usable in spite of the head error. As soon as possible, stop using the print head to prevent further damage. If necessary, get the print head replaced.

3.9.12 Enabling/Disabling External Signal Output

Set this option to enable or disable the printer's external signal communication port. If the port is enabled, you can send and receive data using an appropriate device plugged into the EXT port.

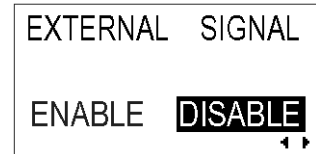

Press the ◀/▶ buttons to select the ENABLE or DISABLE option. The default value is DISABLE.

Press the **ENTER** button to confirm the setting and proceed to the next screen.

3.9.13 Selecting the Type of External Signal Output

If the External Signal Output option is enabled, you will be brought to this screen to select the type of PREND output signal.

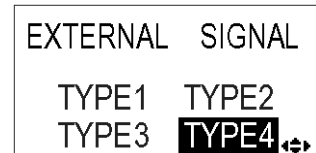

Press the ◀/▶ ▲▼ buttons to select TYPE1, TYPE2, TYPE3 or TYPE4. The default value is TYPE4. For more details, refer to the SBPL Programming Guide found in the accessory CD-ROM.

Press the **ENTER** button to confirm the setting and proceed to the next screen.

3.9.14 Selecting Reprint via External Signal Output

If the External Signal Output option is enabled, you will be brought to this screen to choose whether the Reprint function can be activated via the external signal port.

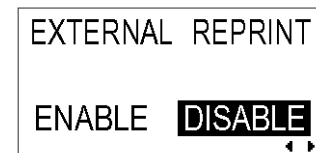

Press the ◀/▶ buttons to select ENABLE or DISABLE. The default setting is DISABLE.

Press the **ENTER** button to confirm the setting and proceed to the next screen.

3.9.15 Using the Auto Online Feature

The printer can be set to go into ONLINE mode automatically upon being turned on. Otherwise, the printer starts in the OFFLINE state.

Press the ◀/▶ buttons to select YES or NO. The default setting is YES.

Press the **ENTER** button to confirm the setting and proceed to the next screen.

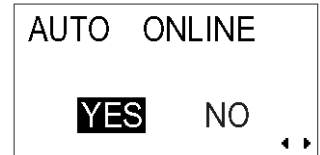

3.9.16 Enabling Auto Feed

The printer can be set to feed one label upon being turned on.

Press the ◀/▶ buttons to select YES or NO. The default setting is NO.

Press the **ENTER** button to confirm the setting and proceed to the next screen.

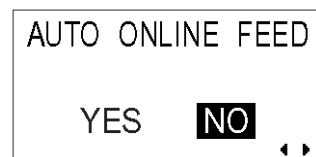

3.9.17 Enabling Auto Feed On Error

The printer can be set to feed one label upon going into ONLINE state after an error has been corrected.

Press the ◀/▶ buttons to select YES or NO. The default setting is NO.

Press the **ENTER** button to confirm the setting and proceed to the next screen.

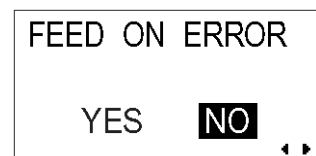

3.9.18 Specifying the Protocol Code Format

The ESC sequence in SBPL commands can be defined as standard (using non-printable code 1BH) or non-standard (some other user code).



Press the ◀/▶ buttons to select the STANDARD or NON-STANDARD option. The default setting is STANDARD.

Press the **ENTER** button to confirm the setting and proceed to the next screen.

3.9.19 Specifying The SEMBL Start Mode

The printer can be set to go into SEMBL Mode automatically (to execute a preloaded BASIC program) upon being turned on.

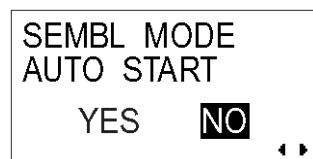

Press the ◀/▶ buttons to select YES or NO. The default setting is NO.

Press the **ENTER** button to confirm the setting and proceed to the last menu screen of the ADVANCED MODE settings.

3.9.20 Specifying The SEMBL Auto Start Program

If the printer has been set to go into SEMBL Mode automatically upon being turned on, this setting will be available to let you specify the program to be automatically executed.

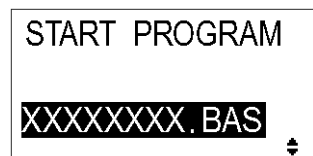

Press the ▲▼ buttons to select from a list of valid programs preloaded into memory. Or select the default NONE option, in which case no program will be automatically executed.

Press the **ENTER** button to return to the first ADVANCED MODE screen.

3.10 HEX DUMP MODE

3.10.1 Entering HEX Dump Mode

1. Press the **LINE** button to take the printer OFFLINE.
2. Pull down the cover of the Operation Panel and press **ENTER**. The ONLINE MODE screen appears.

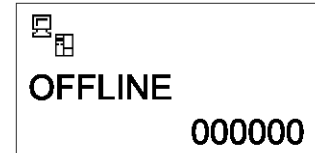

3. Press the arrow buttons until you see "HEX DUMP MODE", then press **ENTER** to perform the first setting. At any time within this mode, pressing **CANCEL** takes you back one screen. Pressing the **FUNCTION** button returns you immediately to the main Hex Dump screen.



3.10.2 Selecting Data To Dump

Here you can choose to dump either incoming data (receive data) or print data already stored in the buffer (receive buffer) .

Press the buttons to choose RECEIVE DATA or RECEIVE BUFFER. Note that RECEIVE BUFFER cannot be selected when there is no received data.

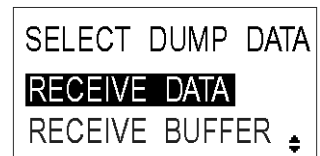

Press the **ENTER** button to confirm the setting and proceed to the next screen.

3.10.3 Controlling the Hex Dump Mode

During the HEX Dump, the following screen appears. The number of labels printed will be shown. When printing is done, press the **LINE** button to take the printer OFFLINE. The press **ENTER** to return to the main HEX DUMP Mode screen.

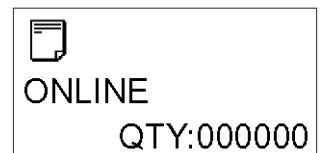

If you dumping the RECEIVE BUFFER, take the printer OFFLINE to stop any incoming data from affecting the buffer. Only then can the buffered data be printed. The printer goes ONLINE automatically after the printing.

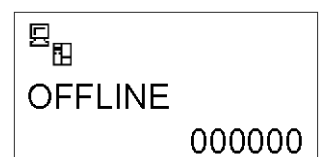

3.11 TEST PRINT MODE

3.11.1 Entering Test Print Mode

1. Make sure the printer is turned OFF.
2. Press and hold down the **FEED** button while turning the printer ON. The display will show TEST PRINT MODE.
3. Press the ▲▼ buttons to choose from six options, as explained in the next sub-section.

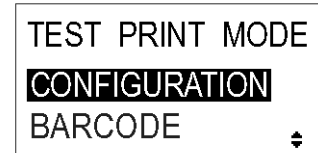
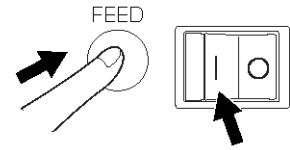

At any time within this mode, pressing **CANCEL** takes you back one screen. Pressing the **FUNCTION** button returns you immediately to the main Test Print screen.

3.11.1 Choosing What The Test Print Contains

The six settings in this mode are as follows:

CONFIGURATION	The configuration settings of the printer will be printed.
BARCODE	The barcodes installed in this printer will be printed.
HEAD CHECK	The head check pattern of the selected paper size area will be printed.
MEMORY	The contents of the memory cartridge installed in this printer will be printed.
FONT	The contents of the fonts installed in this printer will be printed.
FACTORY	The factory test print will be performed.

Press the ▲▼ buttons to choose any option to set the test print contents.

Press the **ENTER** button to confirm the setting and proceed to the next screen.

3.11.2 Setting Test Print Width for Configuration, Barcode and Head Check

If you chose test prints of Configuration, Barcode and Head Check in the previous menu, this screen lets you choose the width of the test print from “04” to “10” cm, in increments of 1 cm,



Press the ▲▼ buttons to choose the print size. Press the **ENTER** button to confirm the setting and proceed to the next screen.

3.11.3 Setting the Size of the Factory Test Print

For Factory test prints, this screen appears instead of the previous screen for setting print size. In this screen, you can choose only to print the test results in LARGE or SMALL print widths. The LARGE setting results in a 10 cm print width. The SMALL setting results in a 4 cm print width.



Caution

If you are using narrow labels, do NOT set this option to LARGE; otherwise, this may damage the print head.

Press the ◀▶ buttons to choose LARGE or SMALL. Press the **ENTER** button to confirm the setting and proceed to the next screen.

3.11.4 Starting the Test Print

When you are ready to print out the test data, press the **ENTER** button. The test print will start, and it will cycle continuously.



During printing, the **ENTER** button can be used to suspend and resume the test printing.

To exit the Test Print mode, turn off the printer.

3.12 OVERVIEW OF ALL MODES

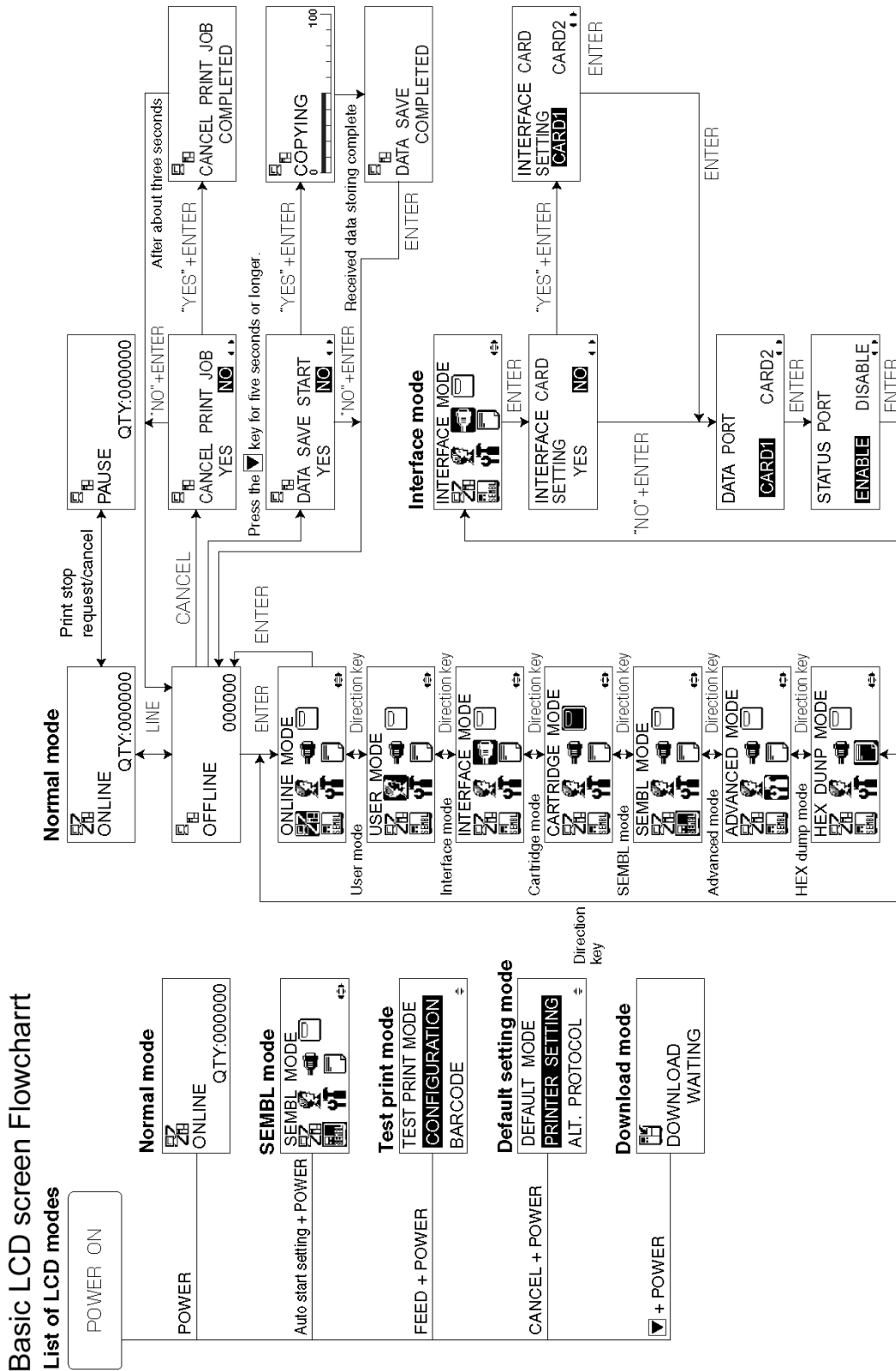

Note: Depending on the firmware version installed on your printer, some of the screens on your printer may not be completely similar to those shown here.

3.12 OVERVIEW OF ALL MODES (CONT'D)

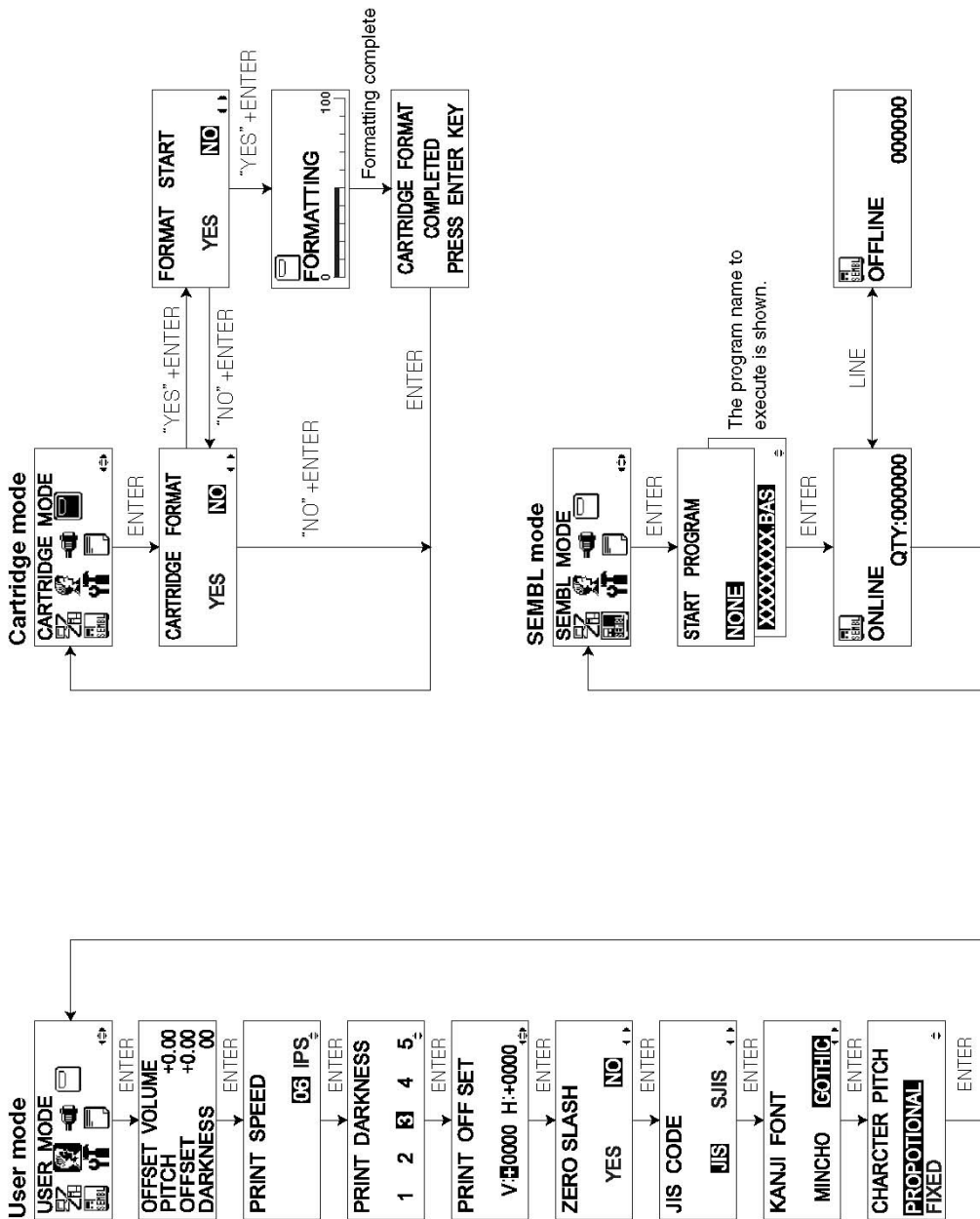

3.12 OVERVIEW OF ALL MODES (CONT'D)

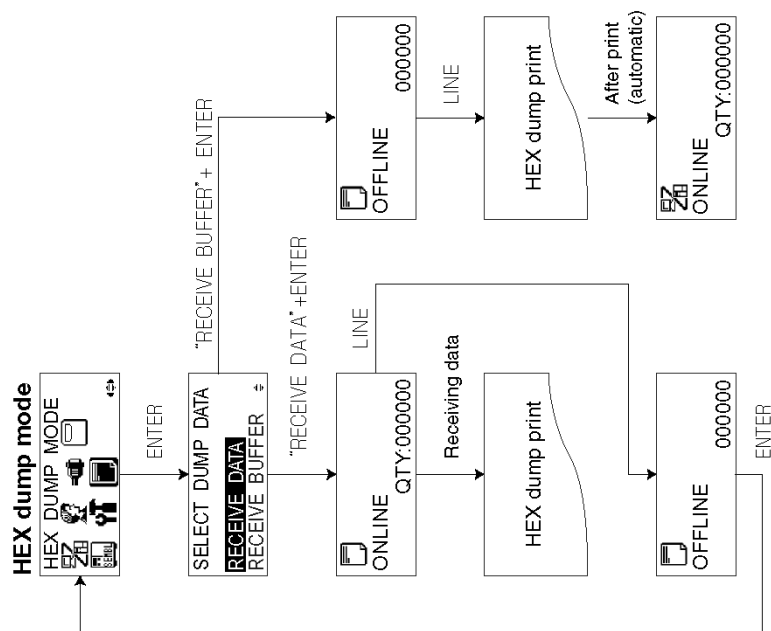
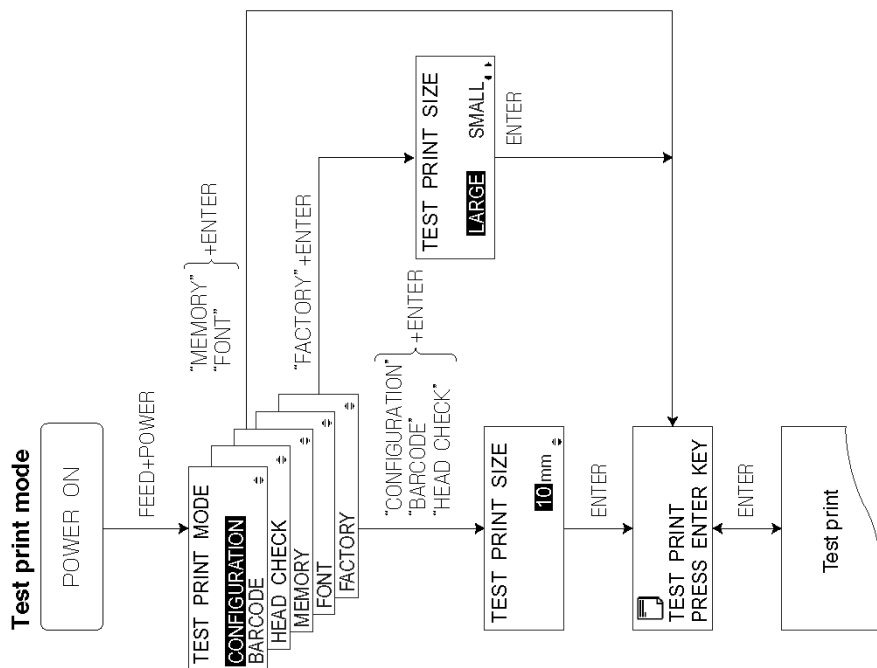

3.12 OVERVIEW OF ALL MODES (CONT'D)

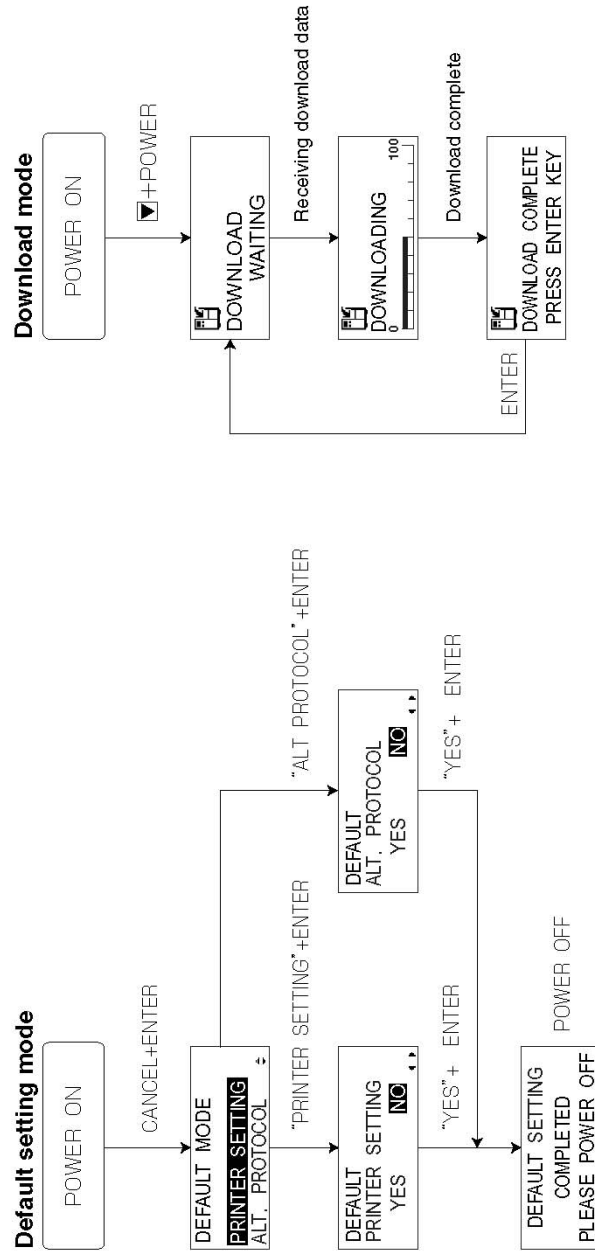

3.12 OVERVIEW OF ADVANCED INTERFACE MODE CONFIGURATIONS (CON'TD)

Interface Mode

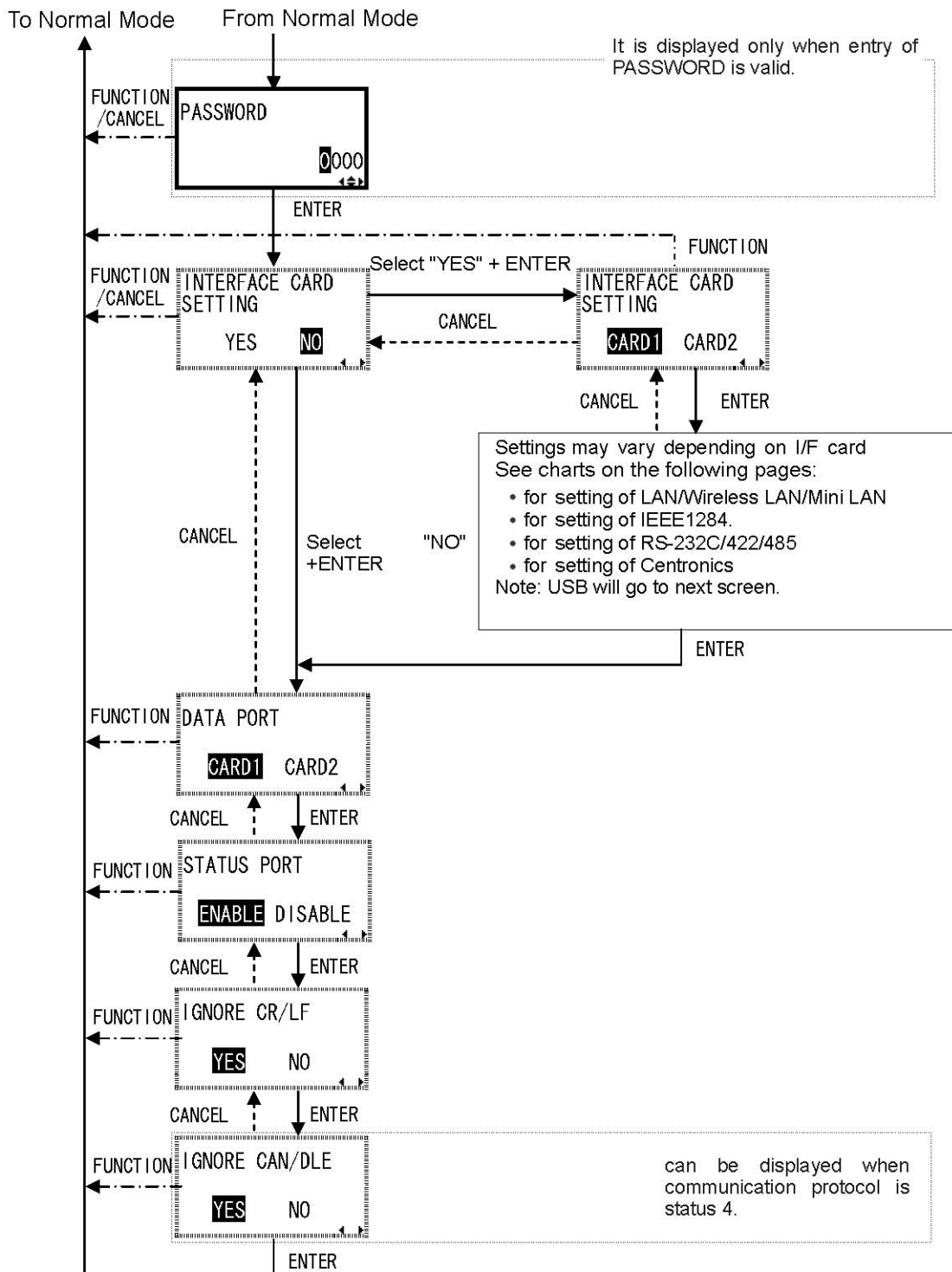

3.12 OVERVIEW OF ADVANCED INTERFACE MODE CONFIGURATIONS (CON'TD)

Setting of LAN/Wireless LAN/Mini LAN

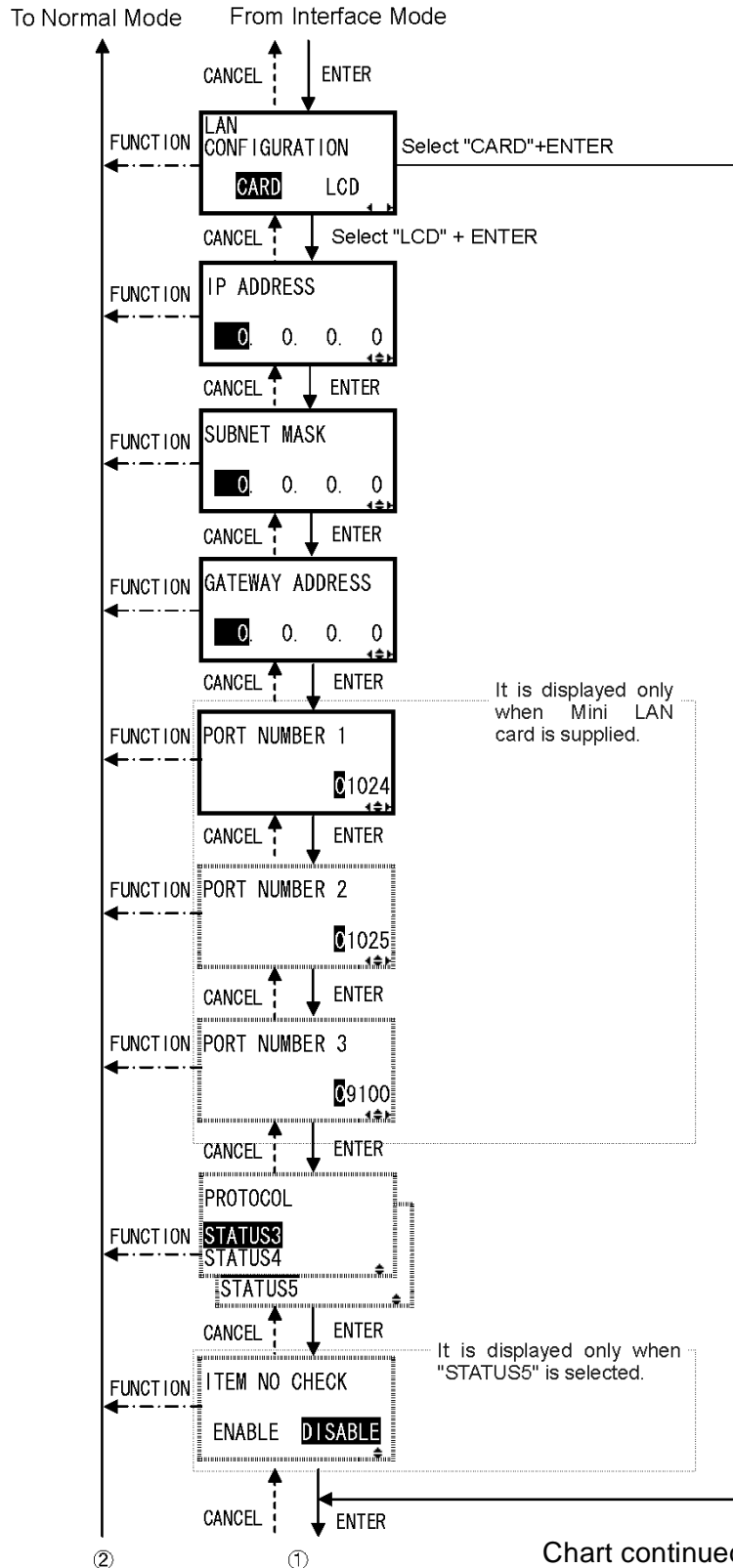

3.12 OVERVIEW OF ADVANCED INTERFACE MODE CONFIGURATIONS (CON'TD)

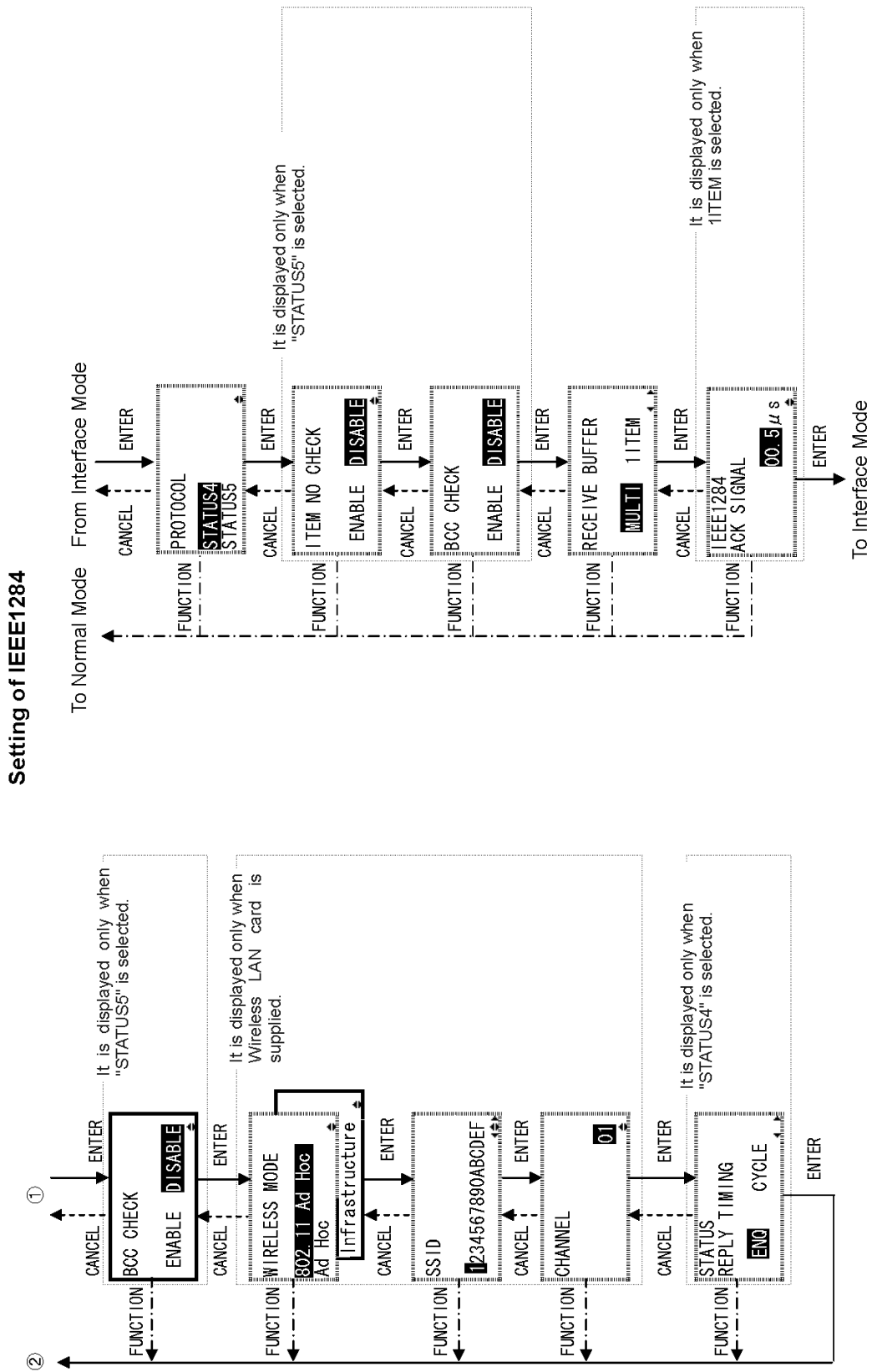

3.12 OVERVIEW OF ADVANCED INTERFACE MODE CONFIGURATIONS (CON'TD)

Setting of RS-232C/422/485

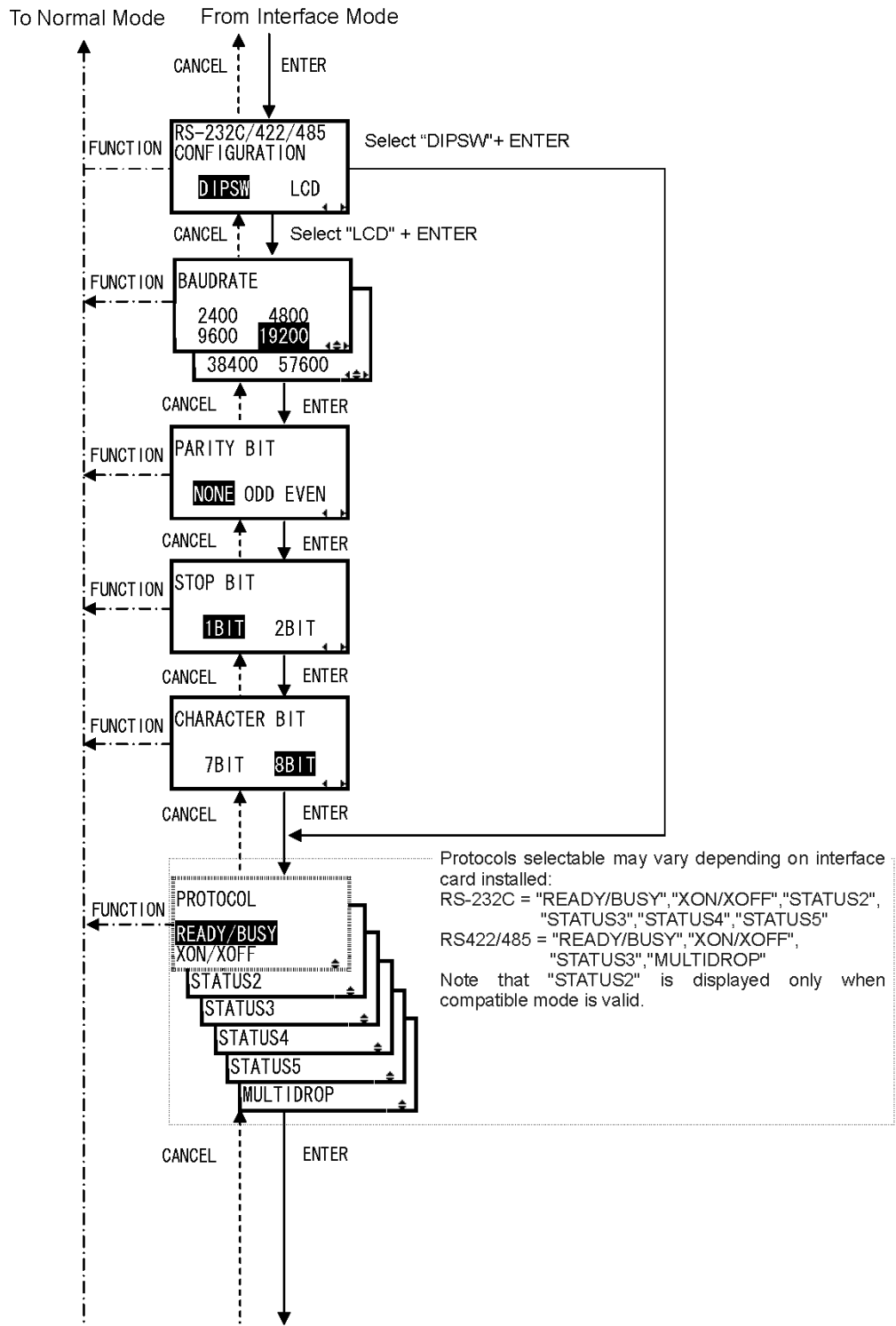
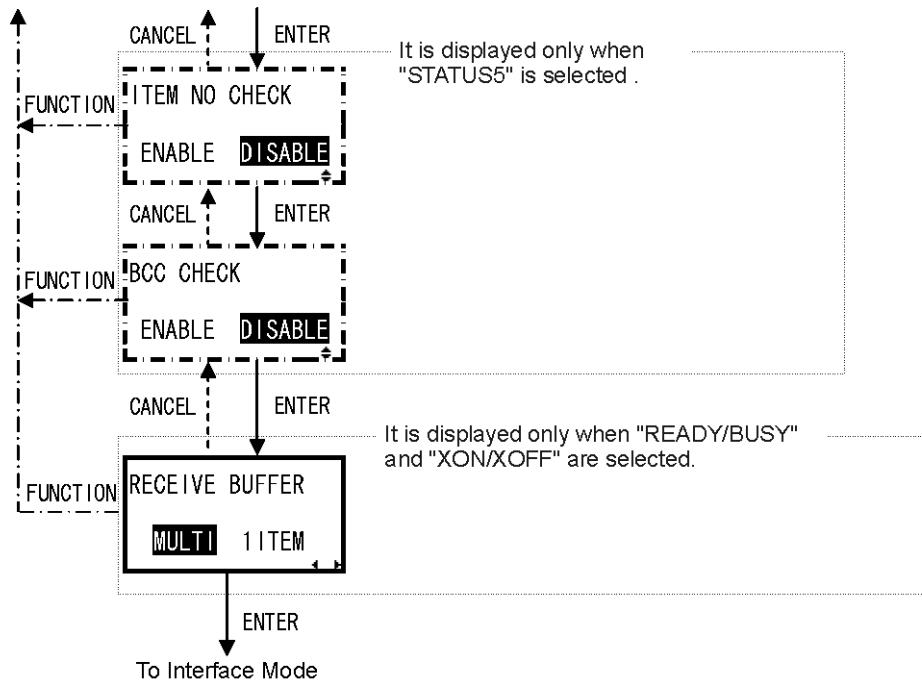
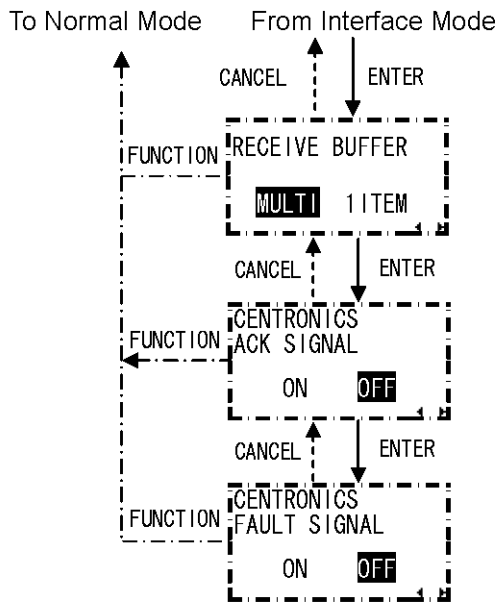

Chart continued on next page →

3.12 OVERVIEW OF ADVANCED INTERFACE MODE CONFIGURATIONS (CON'TD)



Setting of Centronics



Setting of USB

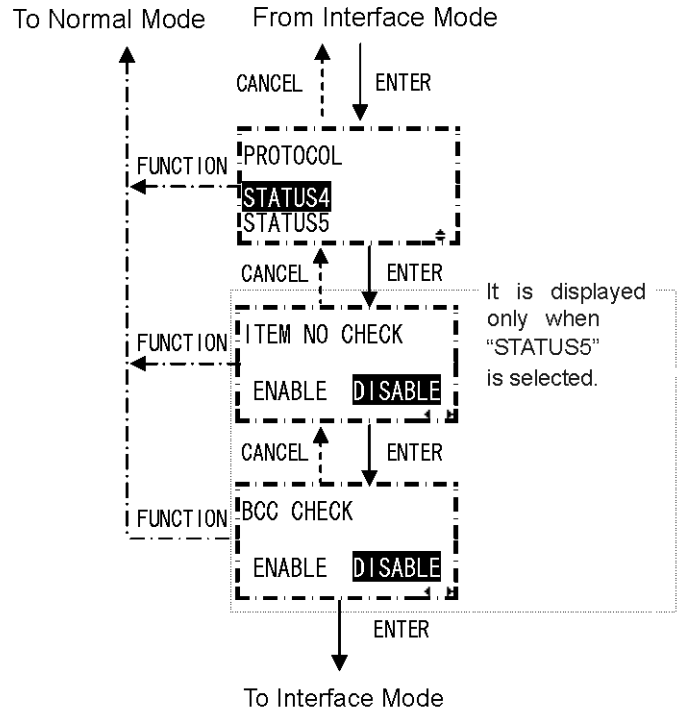



3.13 RESTORING FACTORY DEFAULT SETTINGS

The printer is configured with default settings at the factory. During use, some of the default settings may be changed in a way that causes the printer to act in an undesirable manner. However, there is special Default Mode in which you can quickly restore all printer settings to the original factory settings as shown here:

Item	GT400 Series
Print speed setting	06 ("03" in GT424)
Print density setting	3
Print position correction setting	+0000
Zero slash changeover setting	NO
JIS Kanji code changeover setting	JIS
Kanji font changeover setting	GOTHIC
Proportional pitch setting	FIXED

3.13.1 Entering Default Mode

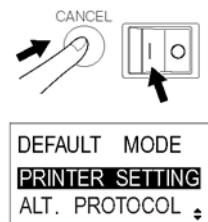

1. Make sure the printer has been turned OFF.
2. Hold down the **CANCEL** button and turn the printer ON. The following DEFAULT MODE display should appear. At any time within this mode, pressing **CANCEL** takes you back one screen. Pressing the **FUNCTION** button returns you immediately to the main Hex Dump screen.
3. Press the   arrow buttons to choose between PRINTER SETTING and ALT. PROTOCOL. The first option resets all settings to the default, while the ALT. PROTOCOL option resets only the protocol code. Press the **ENTER** button to confirm the setting and proceed to the next screen.

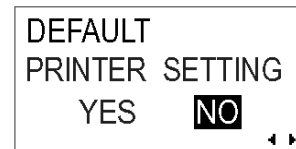

3.13.2 If You Chose to Reset Printer Settings

In the previous menu, if you chose PRINTER SETTINGS, the following screen appears.





4. Press the   arrow buttons to choose between YES and NO. If you select NO, you will return to the main DEFAULT MODE screen.
5. Press **ENTER** to proceed to reset printer settings.

3.13.2 If You Chose Alt Protocol Code

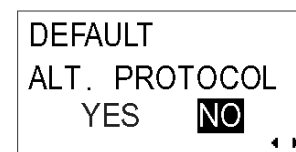
In the previous menu, if you chose the ALT. PROTOCOL option, the following screen appears.



4. Press the   arrow buttons to choose between YES and NO. If you select NO, you will return to the main DEFAULT MODE screen.
5. Press **ENTER** to proceed to reset the Alt. Protocol code.

3.13.3 Completion of Default Setting

After the settings chosen in the previous menus have been reset, the following screen appears.

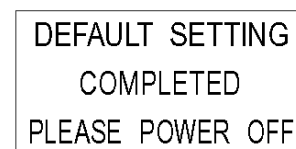

Turn the printer OFF to exit the Default Mode.

3.14 UNDERSTANDING CONTINUOUS PRINT AND TEAR OFF OPERATIONS

The Continuous Print and Tear Off operations are available for use if the printer is not connected to a cutter or peeler. The difference between the two operations is in the way the label paper is ejected. Here are the details:

Continuous Print Operation

In this method of operation, whenever a print job has been completed (or when a sheet of paper is fed) the paper is ejected outwards until the second label from the front is placed just in front of the print head. The first label will not be completely ejected, and cannot be torn off neatly.

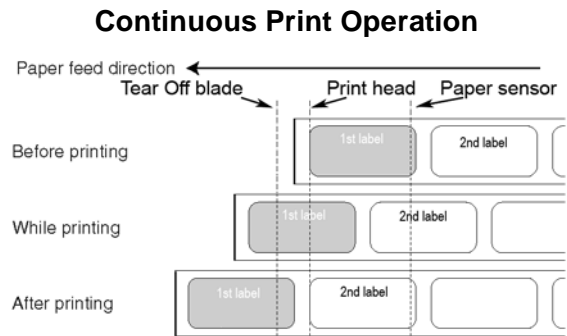

Tear Off Operation

In this method of operation, after printing, the printer feeds the first (outermost) label so that its bottom edge rests at the position of the cutter blade. This label can then be torn off easily.*

However, when the front label is torn off, the label behind it would now have its front edge moved beyond the print head position. Since printing has to begin from the top of a label, the printer therefore performs a backfeed to the frontmost label before printing resumes, so that the first labels' top edge is repositioned behind the print head. Printing can then proceed normally.

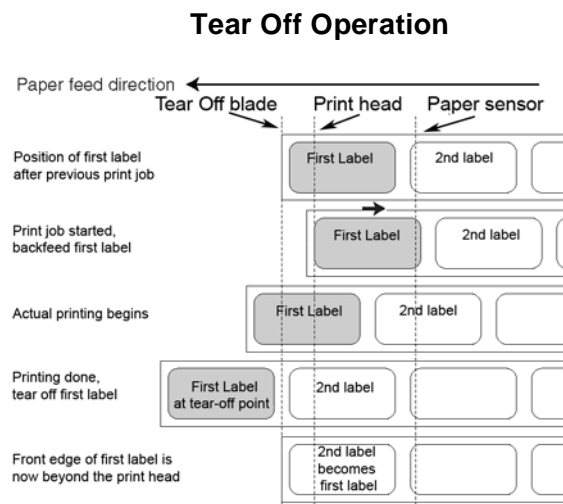

*assuming that this tear-off position has been properly calibrated as discussed in the User Mode **Section 3.5.2 Setting Print Speed.**

This page is intentionally left blank

4

CLEANING AND MAINTENANCE

4.1 INTRODUCTION

This section provides information on user maintenance for the GT Series printers. The following information is covered here:

- Cleaning the Print Head, Platen and Rollers
- Adjusting print quality

4.2 CLEANING THE PRINT HEAD, PLATEN AND ROLLERS

The print head not only generates printouts of barcodes, but also graphics and text. To produce optimal printing, it must be kept clean in spite of the dirt and adhesive that constantly accumulates on its print surface. Furthermore, dirt can accumulate along the label path, affecting parts like sensors and guides, and reducing their performance.

Therefore, it is important to clean these important components periodically. A printer cleaning set and a set of cleaning sheets is provided with every printer. If any of the cleaning items need replacement, contact your authorized SATO dealer.

When to clean with the supplied cleaning set

- ◆ Printer head, platen roller, paper sensor, and label guide: clean after using up every other roll of paper, or each time after printing 150 m.
- ◆ Other parts: clean after finishing every six rolls of paper, or every time after printing 900 m.

When to clean with the supplied cleaning sheet

- ◆ Printer head, platen roller: clean after using every six rolls of paper, or every time after printing 900 m.

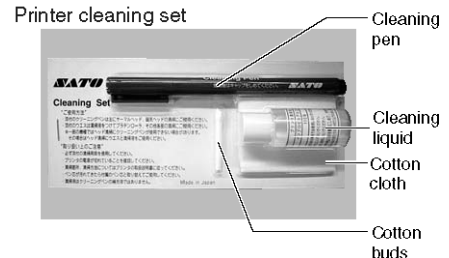

4.3 HOW TO CLEAN THE PRINTER (CLEANING SET)

If you are using a carbon ribbon, be sure to remove it before cleaning. Follow the instructions supplied with the cleaning set. Use the items to clean the following parts.

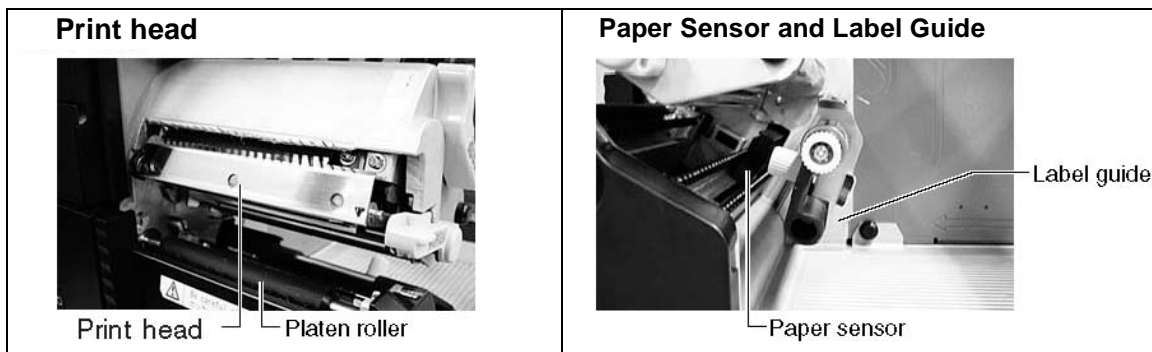

1. Lift up the main cover.
2. Unlatch the print head unit using the head release lever. The print head is now accessible.
3. Wipe off the dirt on the printer head and paper sensor using a cleaning pen. (See figure on the right)

Cleaning of printer head and paper sensor



Printer head

4. Moisten the cotton cloth with cleaning liquid, and use the cloth to wipe any dirt or accumulated adhesive off the platen roller. (See figure on the right)
5. If you are using linerless labels, also wipe off the dirt on the fixed cutter blade with a cleaning pen.

Cleaning of platen roller



Platen roller

4.4 HOW TO CLEAN THE PRINTER (CLEANING SHEET)

The cleaning sheet is used for cleaning the print head and platen roller.

1. Lift up the main cover.
2. Unlatch the print head unit using the head release lever.
The print head is now accessible.
3. Remove the label and the ribbon.
4. Put the head cleaning sheet between the print head and the platen roller. The coarse side of the cleaning sheet should face the surface of the print head elements.
5. Fasten the head-release lever to mount the print head.
6. Using both hands, pull the cleaning sheet outwards, toward your body. This will remove any dirt stuck to the print head.
7. When the cleaning sheet has been removed, perform steps 2 to 6 to repeat the cleaning procedure one or two more times.
8. When no more additional dirt appears on the cleaning sheet after it has been pulled out, you can stop cleaning with the sheet.
9. Unlatch the print head and use the cleaning pen from the cleaning kit to gently remove any remaining dirt from the print head.

Cleaning the printer head



Caution

- Be sure to turn off the power before cleaning.
- The suggested cleaning schedule here are just guidelines. If necessary, clean as appropriate depending on the degree of contamination.
- Use a cleaning pen or cotton cloth to clean the printer units.
- Use only soft, lint-free materials for cleaning. Avoid using hard objects for the cleaning process, as they will damage the components.

4.5 ADJUSTING PRINT QUALITY

Print quality can be optimized with regular cleaning and maintenance of the print head and components along the label path. Additionally, you can fine-tune print quality by adjusting print darkness and print speed settings.

4.5.1 Adjusting Print Darkness

This adjustment allows the user to control (within a specified range) the amount of power applied to the individual print head heat elements. It is important to find a proper print darkness level based on your particular label and ribbon combination. The printed images should not be too light nor should the ink from the ribbon “bleed.” The edges of each image should be crisp and well defined.

LCD Panel — The Print Darkness can be set using the front panel LCD panel or by sending the Print Darkness software command from a computer. There are five settings, from 1 (lightest) to 5 (darkest). The default setting is 3.

Once the range has been selected, the Darkness Potentiometer on the front panel can be used to make finer adjustments. For instructions on setting Print Darkness, refer to Section 3, Configuration.

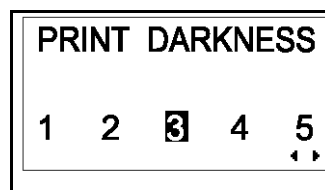

Darkness Potentiometer — The fine adjustment for Print Darkness is the Darkness Potentiometer on the front panel. It provides a continuous range of adjustment, allowing you to make precise changes. Use a small cross-point screwdriver, turning clockwise for darker print and counterclockwise for lighter print. See Section 3: Configuration for instructions on performing potentiometer adjustments.

Note

The PRINT potentiometer adjustment will affect the darkness in all of the command code speed ranges, i.e., if the PRINT potentiometer is adjusted for lighter print, the darkness will be lighter in all speed ranges selected by the command code.



4.5 ADJUSTING PRINT QUALITY (CONT'D)

4.5.2 Adjusting Print Speed

Besides varying the rate at which labels are printed, this adjustment can be used to regulate any changes in print quality.

LCD Panel — Print Speed can be set using the front panel LCD panel or by sending the Print Speed software command from a computer. On the GT408 and GT412, there are 11 settings, from 02 ip/s (slowest) to 12 ip/s (faster). The default setting is 6. On the GT424, there are five settings, from 02 ip/s to 06 ip/s, and the default setting is 3 ip/s.

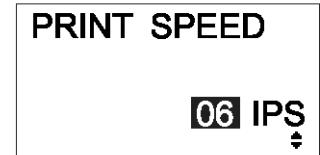

For instructions on setting Print Speed, refer to page 3-7, Operation and Configuration.

This page is intentionally left blank

5

INTERFACE SPECIFICATIONS

5.1 INTERFACE TYPES

At the time of purchase, the GT Series printers are supplied with a single interface of the user's choice: typically a parallel interface is used for transmitting data to and from the host, and an optional external signal interface for connecting to other peripherals. Additionally, an optional Mini-LAN card can be installed in the GT series to provide printer status information to a LAN.

The following are the different types of interface boards available:

- 1) RS232C Interface Board
- 2) Parallel Interface Board
- 3) IEEE 1284 Interface Board
- 4) USB Interface Board (Ver. 2.0)
- 5) LAN Interface Board (10Base-T/100Base-T)
- 6) IEEE 802.11b Wireless LAN Interface Board
- 7) Mini LAN Interface Board (10Base-T/100Base-T)
- 8) External Signal Interface Board

5.2 INTERFACE CARD DIP SWITCH SETTINGS (RS-232C)

The GT400 series super-speed serial interface card (optional) contains DIP switches for controlling communication conditions. The DIP switch functions are:

Switch No.	Function	Description	
1	Data length setting	ON: 7 Data Bits OFF: 8 Data Bits	
2	Parity bit setting	OFF — OFF: None	
3		OFF — ON: Even number ON — OFF: Odd number ON — ON: Not used	
4	Stop bit setting	ON: 2 Stop Bits OFF: 1 Stop Bit	
5	Baud rate setting	OFF — OFF: 9600 bps	
6		OFF — ON: 19200 bps ON — OFF: 38400 bps ON — ON: 37600 bps	
7	Communication Protocol setting	1-7 1-8 Compatibility mode OFF	Compatibility mode ON
8		OFF OFF: READY/BUSY OFF ON : XON/XOFF ON OFF : Driver specific protocol ON ON : Not used	READY/BUSY XON/XOFF Status 3 Not used

Caution

Always turn the printer OFF before attaching or detaching an interface card. Otherwise, severe electrical damage may be incurred, or bodily injury may be sustained.

Note:

Check the setting seal of the serial interface card.

The correct settings may vary depending on the type and revision of the board.

Any communication settings not controlled by the DIP switches can be set in the printer's Interface Mode (See Section 3.6) using the operation panel.

5.3 INTERFACE CARD DIP SWITCH SETTINGS (LAN)

The GT400 series Local Area Network interface card (optional) contains DIP switches for initializing LAN configuration, LAN printing configuration, and LAN card self-diagnosis. The DIP switch functions are:

Switch No.	GT400 series LAN Interface Card function
1	Unused
2	Initializes LAN card configuration information
3	Prints LAN card configuration information (configuration information such as the IP address will be printed)
4	Prints LAN card self-examination (results of LAN card examination will be printed)

5.4 INTERFACE CARD DIP SWITCH SETTINGS (WIRELESS LAN)

The GT400 series Wireless Local Area Network interface card (optional) contains DIP switches for initializing LAN configuration, LAN printing configuration, LAN card self-diagnosis and wireless mode settings. The DIP switch settings must be made before installing the card into the printer. The DIP switch functions are:

Switch No.	GT400 series Wireless LAN Interface Card function	
1	Unused	
2	Initializes LAN card configuration information	
3	Prints LAN card configuration information (configuration information such as the IP address will be printed)	
4	Prints LAN card self-examination (results of LAN card examination will be printed)	
5	Wireless Communication mode	OFF—OFF : 802.11 Ad hoc
6		OFF—ON : Infrastructure ON—OFF : Ad hoc ON—ON : Unused

5.5 INTERFACE CARD DIP SWITCH SETTINGS (MINI LAN)

The GT400 series Local Area Network interface card (optional) contains DIP switches for initializing LAN configuration, LAN printing configuration, and LAN card self-diagnosis. The DIP switch settings must be made before installing the card into the printer. The DIP switch functions are:

Switch No.	GT400 series LAN Interface Card function
1	Unused
2	Initializes LAN card configuration information
3	Prints LAN card configuration information (configuration information such as the IP address will be printed)
4	Prints LAN card self-examination (results of LAN card examination will be printed)

5.6 SERIAL INTERFACE SPECIFICATIONS (RS-232C)

The serial interface of this printer conforms to the RS-232C standard.

There are two types of receive modes: 1. Single Job Buffer 2. Multi Job Buffer

These can be set using the dip switches.

Basic Specifications

Standard Interface	Inside the printer																																																																																			
Dip Switch 1) Character configuration 2) Transmission speed 3) Protocol	<table border="1"> <tr> <td rowspan="2">1-1</td> <td rowspan="2">Data bit length</td> <td colspan="2">OFF</td> <td>8 bits</td> </tr> <tr> <td colspan="2">ON</td> <td>7 bits</td> </tr> <tr> <td rowspan="4">1-2 1-3</td> <td rowspan="4">Parity bit (2-3)</td> <td>DSW1-2</td> <td>DSW1-3</td> <td></td> </tr> <tr> <td>OFF</td> <td>OFF</td> <td>NONE</td> </tr> <tr> <td>OFF</td> <td>ON</td> <td>EVEN</td> </tr> <tr> <td>ON</td> <td>OFF</td> <td>ODD</td> </tr> <tr> <td></td> <td></td> <td>ON</td> <td>ON</td> <td>Not used</td> </tr> <tr> <td rowspan="2">1-4</td> <td rowspan="2">Stop bit</td> <td colspan="2">OFF</td> <td>1 bit</td> </tr> <tr> <td colspan="2">ON</td> <td>2 bits</td> </tr> <tr> <td rowspan="4">1-5 1-6</td> <td rowspan="4">Baud rate (5-6)</td> <td>DSW1-5</td> <td>DSW1-6</td> <td>DIPSW2-8 OFF</td> <td>DIPSW2-8 ON</td> </tr> <tr> <td>OFF</td> <td>OFF</td> <td>9600bps</td> <td>9600bps</td> </tr> <tr> <td>OFF</td> <td>ON</td> <td>19200bps</td> <td>19200bps</td> </tr> <tr> <td>ON</td> <td>OFF</td> <td>38600bps</td> <td>4800bps</td> </tr> <tr> <td></td> <td></td> <td>ON</td> <td>ON</td> <td>57600bps</td> <td>2400 bps</td> </tr> <tr> <td rowspan="4">1-7 1-8</td> <td rowspan="4">Protocol (7-8)</td> <td>DSW1-7</td> <td>DSW1-8</td> <td>DIPSW2-8 OFF</td> <td>DIPSW2-8 ON</td> </tr> <tr> <td>OFF</td> <td>OFF</td> <td>Ready/Busy</td> <td>Ready/Busy</td> </tr> <tr> <td>OFF</td> <td>ON</td> <td>X-on-Xoff</td> <td>X-on-Xoff</td> </tr> <tr> <td>ON</td> <td>OFF</td> <td>Status 3 echo</td> <td>Status 3 echo</td> </tr> <tr> <td></td> <td></td> <td>ON</td> <td>ON</td> <td>Driver protocol</td> <td>Status2 echo</td> </tr> </table>	1-1	Data bit length	OFF		8 bits	ON		7 bits	1-2 1-3	Parity bit (2-3)	DSW1-2	DSW1-3		OFF	OFF	NONE	OFF	ON	EVEN	ON	OFF	ODD			ON	ON	Not used	1-4	Stop bit	OFF		1 bit	ON		2 bits	1-5 1-6	Baud rate (5-6)	DSW1-5	DSW1-6	DIPSW2-8 OFF	DIPSW2-8 ON	OFF	OFF	9600bps	9600bps	OFF	ON	19200bps	19200bps	ON	OFF	38600bps	4800bps			ON	ON	57600bps	2400 bps	1-7 1-8	Protocol (7-8)	DSW1-7	DSW1-8	DIPSW2-8 OFF	DIPSW2-8 ON	OFF	OFF	Ready/Busy	Ready/Busy	OFF	ON	X-on-Xoff	X-on-Xoff	ON	OFF	Status 3 echo	Status 3 echo			ON	ON	Driver protocol	Status2 echo
	1-1			Data bit length	OFF		8 bits																																																																													
		ON			7 bits																																																																															
	1-2 1-3	Parity bit (2-3)	DSW1-2	DSW1-3																																																																																
			OFF	OFF	NONE																																																																															
			OFF	ON	EVEN																																																																															
			ON	OFF	ODD																																																																															
			ON	ON	Not used																																																																															
	1-4	Stop bit	OFF		1 bit																																																																															
			ON		2 bits																																																																															
	1-5 1-6	Baud rate (5-6)	DSW1-5	DSW1-6	DIPSW2-8 OFF	DIPSW2-8 ON																																																																														
			OFF	OFF	9600bps	9600bps																																																																														
			OFF	ON	19200bps	19200bps																																																																														
			ON	OFF	38600bps	4800bps																																																																														
		ON	ON	57600bps	2400 bps																																																																															
1-7 1-8	Protocol (7-8)	DSW1-7	DSW1-8	DIPSW2-8 OFF	DIPSW2-8 ON																																																																															
		OFF	OFF	Ready/Busy	Ready/Busy																																																																															
		OFF	ON	X-on-Xoff	X-on-Xoff																																																																															
		ON	OFF	Status 3 echo	Status 3 echo																																																																															
		ON	ON	Driver protocol	Status2 echo																																																																															
<p>* The switch between Single Job Buffer and Multi Job Buffer can be specified using dip switches 2-5 in the printer. Also, the communication setting can be switched using dip switches 2-8 in the printer.</p>																																																																																				
Synchronization mode	Asynchronous																																																																																			
Maximum Receivable Buffer capacity	2.95Mbyte 																																																																																			
Code used	ASCII(7 bit) Graphics(8 bit)																																																																																			
Connectors	Printer side DB-25S (Female) Cable side DB-25P (Male) Cable length 5 meters or less																																																																																			
Transmission format	<table border="1"> <tr> <td>Start</td> <td>b1</td> <td>b2</td> <td>b3</td> <td>b4</td> <td>b5</td> <td>b6</td> <td>b7</td> <td>b8</td> <td>Stop</td> </tr> </table> <p>Note b8 is not applicable when using 7 bits.</p>	Start	b1	b2	b3	b4	b5	b6	b7	b8	Stop																																																																									
Start	b1	b2	b3	b4	b5	b6	b7	b8	Stop																																																																											
Signal level	High level: +5 ~ +12V Low level: -5 ~ -12V																																																																																			

5.7 READY/BUSY

Ready / Busy is the hardware flow control method for the serial interface on the printer. Data received cannot be guaranteed, when print data (ESC+"A"~ESC+"Z") is sent from the host, under the following conditions:

- 1) When the printer is Offline
- 2) When an error has occurred in the printer

Pin Assignments

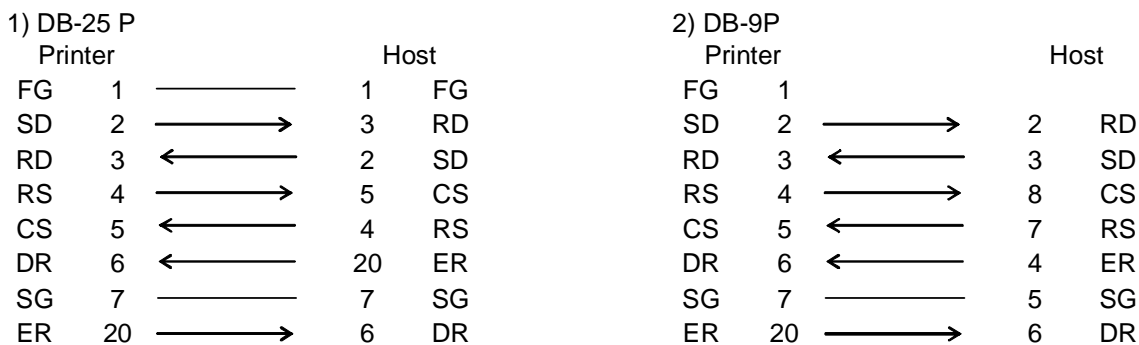

When using Windows Hardware Control:

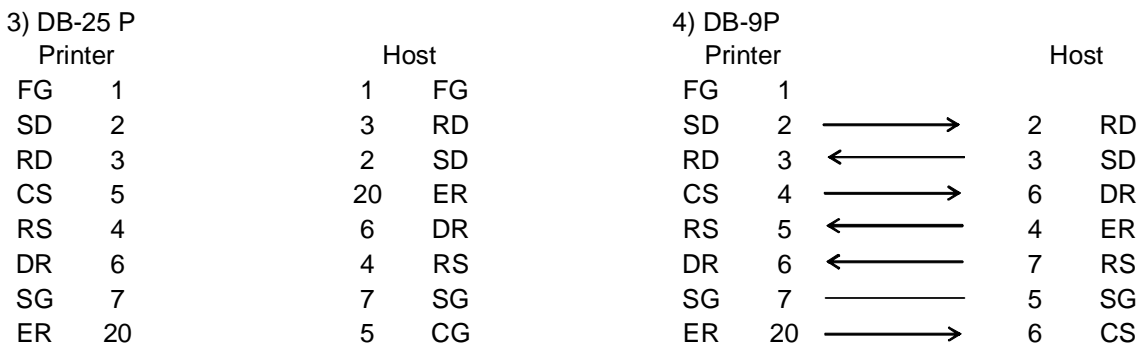

Interface Signals

Pin no.	Signal Type	Direction	Contents
1	FG	-	Frame Ground
2	SD	Output	Send Data
3	RD	Input	Receive Data
4	RS	Output	Request to Send
5	CS	Input	Clear to Send
6	DR	Input	Data Set Ready
7	SG	-	Signal Ground
20	ER	Output	Error

5.8 SINGLE JOB BUFFER

Timing Chart — Normal Processing

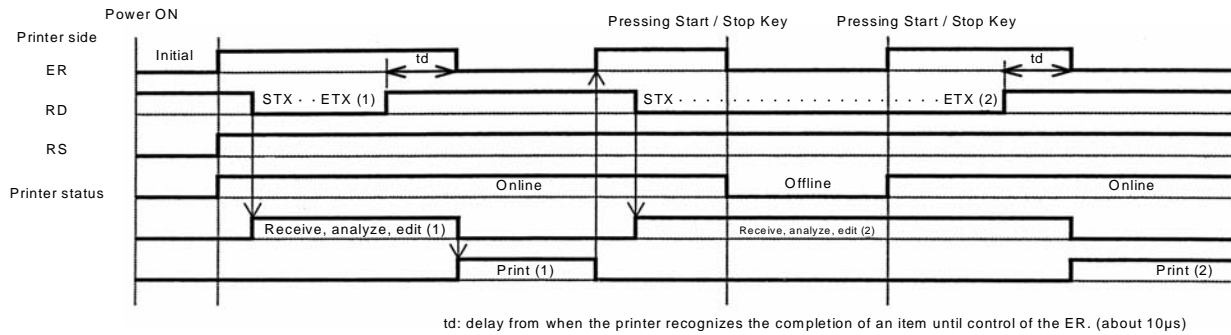

Timing Chart — Error Processing

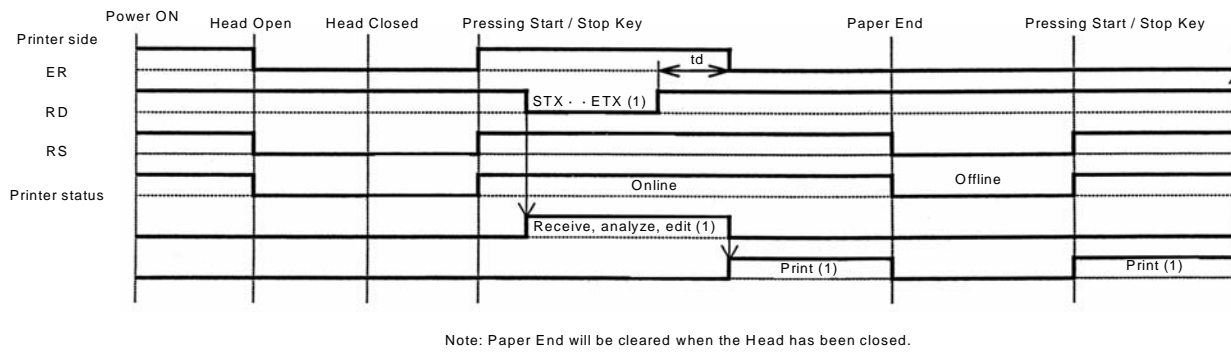

5.9 MULTI JOB BUFFER

Timing Chart — Normal Processing

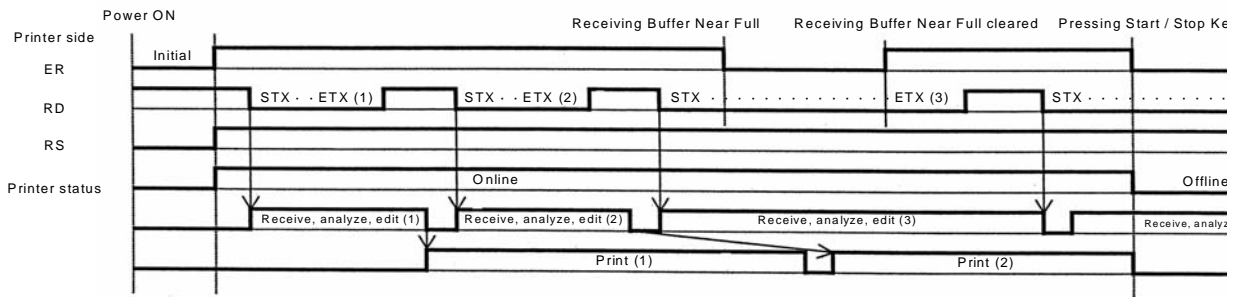

Note: Data will be normally be received Online, during Multi-reception.

Timing Chart — Error Processing

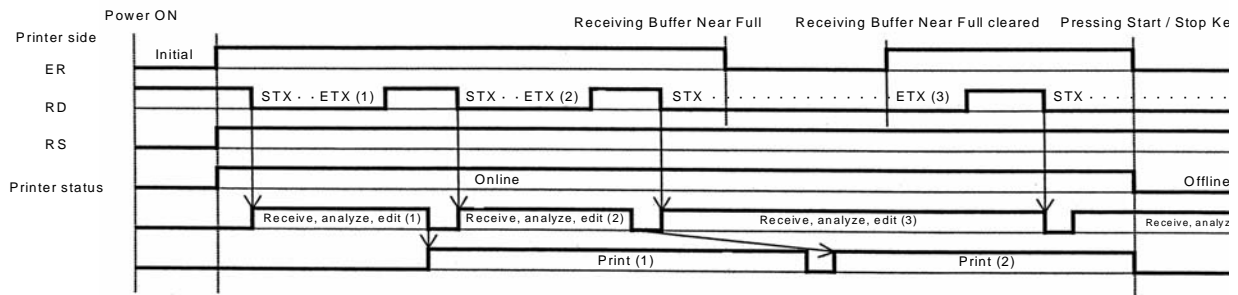

Note: Data will be normally be received Online, during Multi-reception.

5.10 X-ON/X-OFF

This transmission protocol informs the host if the printer can receive data or not, by sending the "XON" (Hex 11H) or "XOFF" (Hex 13H) code.

Data received cannot be guaranteed, when print data (ESC+"A"~ESC+"Z") is sent from the host, under the following conditions:

- 1) When the printer is Offline
- 2) When an error has occurred in the printer

Pin Assignments

1) DB-25 P				2) DB-9P			
Printer		Host		Printer		Host	
FG	1	1	FG	FG	1		
SD	2	3	RD	SD	2		2
RD	3	2	SD	RD	3		3
RS	4	5	CS	RS	4		8
CS	5	4	RS	CS	5		7
DR	6	20	ER	DR	6		4
SG	7	7	SG	SG	7		5
ER	20	8	DR	ER	20		6

Caution!

In the connections, it may be necessary to loop (usually kept "High) CS and RS on the host side depending on the type of host. Therefore, make sure to re-check the host before use.

Input/Output Signals

Pin no.	Signal Type	Direction	Contents
1	FG	-	Frame Ground
2	SD	Output	Send Data
3	RD	Input	Receive Data
7	SG	-	Signal Ground

5.11 SINGLE JOB BUFFER

Timing Chart — Normal Processing

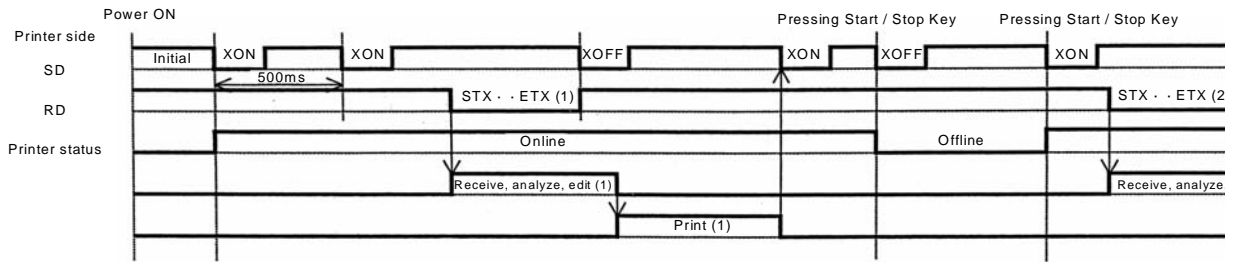

Note: This protocol will execute an "XON" polling at an interval of 500ms, from the moment the power is turned on until the receipt

Timing Chart — Error Processing

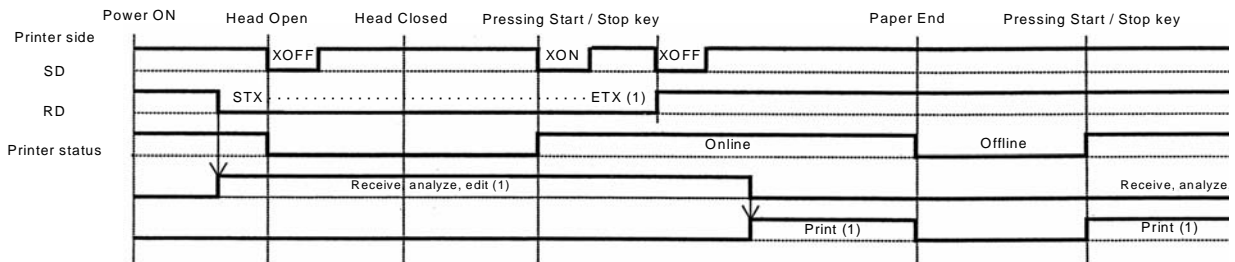

Note: Paper End will be cleared when the Head has been closed.

5.12 MULTI JOB BUFFER

Timing Chart — Normal Processing

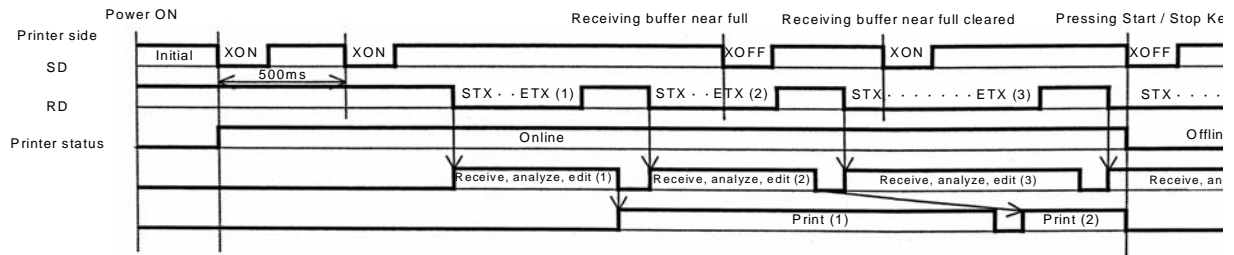

Note: This protocol will execute an "XON" polling at an interval of 500ms, from the moment the power is turned on until the receipt

Timing Chart — Error Processing

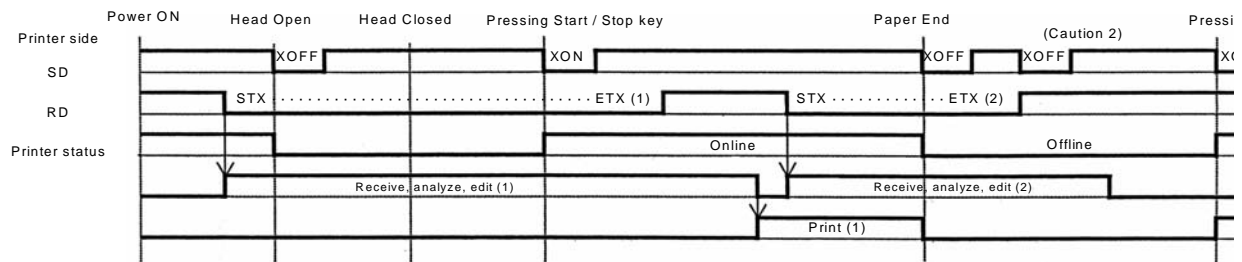

Note: Paper End will be cleared when the Head has been closed.
 Note 2: An "XOFF" transmission will be executed when receiving data during the occurrence of an error

5.13 DRIVER PROTOCOL

This transmission protocol responds the status from the printer by using Enquire commands from the host to check the printer status.

The status is immediately responded after the Enquire command has been received.

When using this protocol, the receive buffer should be set to Multi-Job Buffer.

Pin Assignments

1) DB-25 P			2) DB-9P					
Printer		Host	Printer		Host			
FG	1	1	FG	1				
SD	2	3	RD	2	2	RD		
RD	3	2	SD	3	3	SD		
RS	4	5	CS	4	8	CS		
CS	5	4	RS	5	7	RS		
DR	6	20	ER	6	4	ER		
SG	7	7	SG	7	5	SG		
ER	20	6	DR	20	6	DR		

Caution!

In the connections, it may be necessary to loop (usually kept "High) CS and RS on the host side depending on the type of host. Therefore, make sure to re-check the host before use.

Input/Output Signals

Pin no.	Signal Type	Direction	Contents
1	FG	-	Frame Ground
2	SD	Output	Send Data
3	RD	Input	Receive Data
7	SG	-	Signal Ground

5.13 DRIVER PROTOCOL (CONT'D)

Timing Chart — Normal Processing

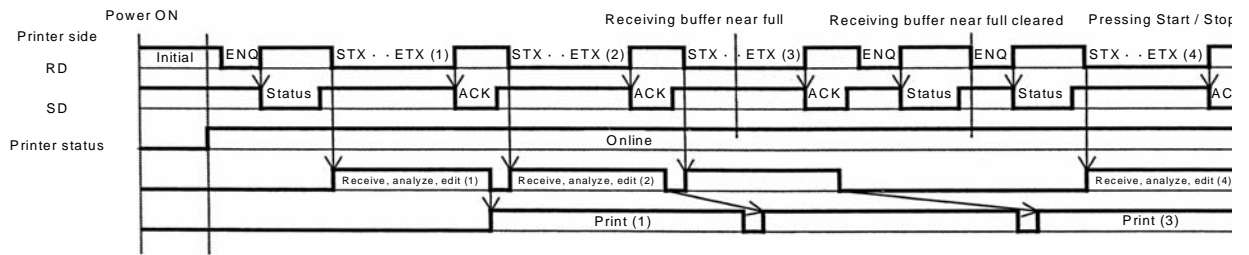

Timing Chart — Cancel Processing

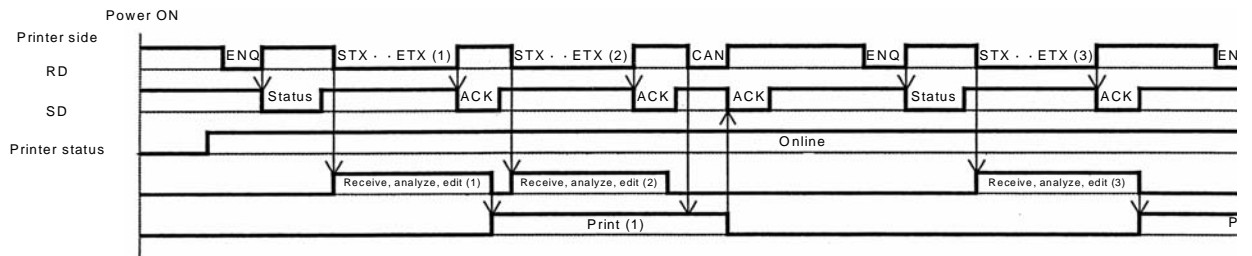

5.13 DRIVER PROTOCOL (CONT'D)

Timing Chart — Error Processing

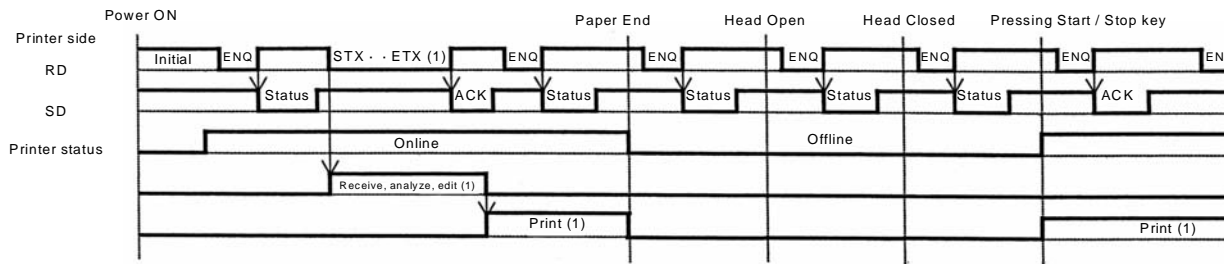

Timing Chart — Pause and Restart Processing

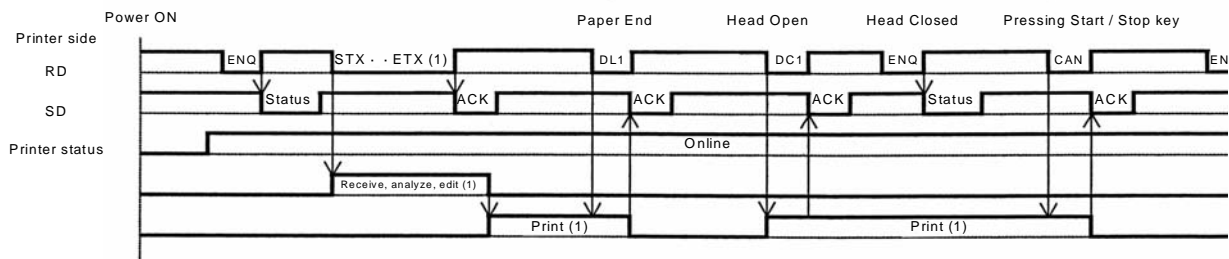

5.13 DRIVER PROTOCOL (CONT'D)

Timing Chart — Status Response Processing

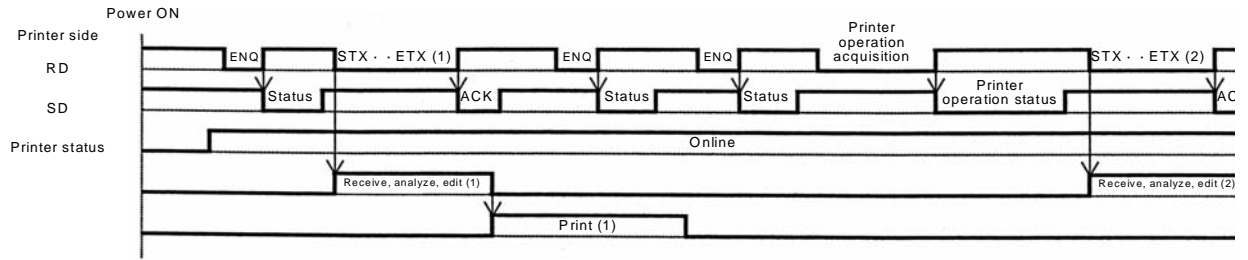

Note: Do not execute status acquisition commands (SOH+MG) while printing.

5.13 DRIVER PROTOCOL (CONT'D)

Status Response

This transmission protocol responds to the host the printer's information, as a status by receiving printing commands or 2 types of requested commands.

The details of each requested command or Status response is as follows.

(1) Status Request Command

In receiving this command, the ID number of received data currently being printed and the printer's condition, as well as the remaining quantity of print jobs and their names, are responded to the host. Furthermore, after printing or if no data has been received, or if the ID command has not been specified, the ID number will be responded back as spaces (Hex 20H), and the quantity of print jobs will be responded back as all zeroes (Hex 30H).

- a) Command ENQ (Hex 05H)
- b) Responded Status Definition

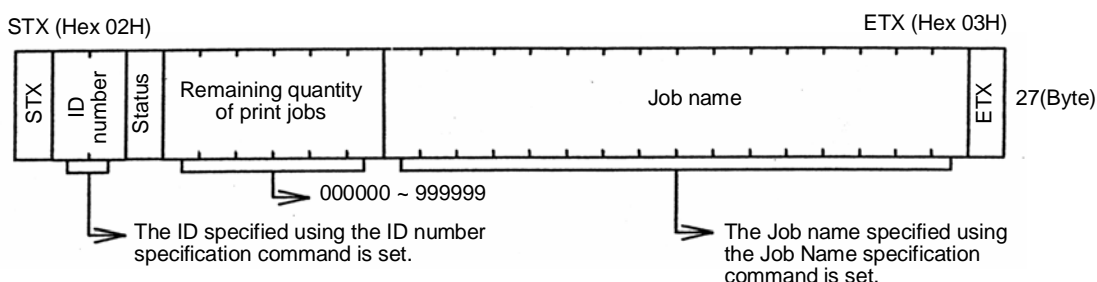

c) Status Byte Definition

Contents		ASCII	Hex	
Offline	No errors	0	30	
	Ribbon near end	1	31	
	Buffer near full	2	32	
	Ribbon near end and buffer near full	3	33	
	Printing stopped (no errors)	4	34	
Online	Reception Standby	No errors	A	41
		Ribbon near end	B	42
		Buffer near full	C	43
		Ribbon near end and buffer near full	D	44
		Printing stopped (no errors)	E	45
	Printing	No errors	G	47
		Ribbon near end	H	48
		Buffer near full	I	49
		Ribbon near end and buffer near full	J	4A
		Printing stopped (no errors)	K	4B
	Standby (dispenser cut standby)	No errors	M	4D
		Ribbon near end	N	4E
		Buffer near full	O	4F
		Ribbon near end and buffer near full	P	50
		Printing stopped (no errors)	Q	51
	Analyzing / Editing	No errors	S	53
		Ribbon near end	T	54
Buffer near full		U	55	
Ribbon near end and Buffer near full		V	56	
Printing stopped (no errors)		W	57	
Error detection	Head open	b	62	
	Paper End	c	63	
	Ribbon end	d	64	
	Media error	e	65	
	Sensor error	f	66	
	Head error	g	67	
	Card error	i	69	
	Cutter error	j	6A	
	Other errors	k	6B	
	Cutter sensor error	l	6C	
	Stacker Full	m	6D	

5.13 DRIVER PROTOCOL (CONT'D)

(2) Cancel Request Command

In receiving this command, printing is aborted and the contents of the receive buffer are completely cleared.

The Status response is the status of the printer after this procedure has been completed. After sending the cancel request command, the next data should be sent after a lapse of more than 100ms.

- a) Command CAN (Hex 18H)
- b) Status Byte Definition

Status	Contents
ACK (Hex 06H)	Indicates that there is no printer error
NAK (Hex 15H)	Indicates that there is a printer error

StatusContents

ACK (Hex 06H)Indicates that there is no printer error

NAK (Hex 15H)Indicates that there is a printer error

(3) Print Stop Request

In receiving this command, printing is stopped.

The status responds is the status of the printer after the receiving process has been completed.

- a) Command DLE (Hex 10H)
- b) Status Byte Definition

Status	Contents
ACK (Hex 06H)	Indicates that there is no printer error
NAK (Hex 15H)	Indicates that there is a printer error

(4) Print Start Request

In receiving this command, Print Stop Request is cancelled and printing starts.

The status response is the status of the printer after the receiving process has been completed.

- a) Command DC1 (Hex 11H)
- b) Status Byte Definition

Status	Contents
ACK (Hex 06H)	Indicates that there is no printer error
NAK (Hex 15H)	Indicates that there is a printer error

5.13 DRIVER PROTOCOL (CONT'D)

3) Other Status Responses

(1) Operating Status request

In receiving this command, the printer settings are responded to the host.

- a) Command SOH (01H) + MG
- b) Responded status definition
STX + the following status (30 bytes) + ETX
- c) Status Byte Definition

No.	Item	Contents	Byte no.
1	Printing method	00H: Thermal transfer 01H: Thermal	1
2	Head Density	00H: 200 (dpi) 8 (rolls/mm) 01H: 300 (dpi) 12 (rolls/mm)	1
3	Printing speed	02H: 4 (inch/s) 100 (mm/s) 03H: 5 (inch/s) 125 (mm/s) 04H: 6 (inch/s) 150 (mm/s) 05H: 7 (inch/s) 175 (mm/s) 06H: 8 (inch/s) 200 (mm/s)	1
4	Printing	00H: Consecutive 02H: Cutter	1
5	Print Area Expansion	00H: Standard 01H: Expanded	1
6	Reserved		1
7	Reserved		1
8	Print Darkness	Range A(41H): A B (42H): B C (43H): C D (44H): D E (45H): E F (46H): F Darkness 00H: 1 01H: 2 02H: 3	2
9	Sensor type	03H: Center hole 04H: Side hole 05H: R-Corner 06H: Reflective sensor (I- mark) 07H: Transparent sensor (Gap) 08H: Reflective sensor (I- mark) 09H: Sensor inactive	1

5.13 DRIVER PROTOCOL (CONT'D)

c) Status Responses (cont'd)

No.	Item	Contents	Byte no.
10	Zero Slash	00H: Disable 01H: Enable	1
11	Reserved		1
12	Reserved		1
13	Reserved		1
14	Character Gap	00H: Fixed pitch 01H: Proportional pitch	1
15	Vertical label size	Maximum vertical label size may change depending on the printer.	2
16	Horizontal label size	Maximum horizontal label size may change depending on the printer.	2
17	Vertical base reference point offset	00H – 3C0H (0 – 960 dots)	2
18	Horizontal base reference point offset	00H – 3C0H (0 – 960 dots)	2
19	Reserved		1
20	Reserved		1
21	Reserved		1
22	Reserved		1
23	Reserved		1
24	Reserved		1
25	Buzzer settings	00H : Enabled 01H : Disabled	1

(2) System Version Data Request

In receiving this command, the printer system version information is responded.

- a) Command SOH (01H) + SB
- b) Responded Status Definition
STX + Printer System Version + ETX
- c) Status Byte Definition

No.	Item	Contents	Byte number
1	Operating system	ASCII code	10
2	Printer firmware	ASCII code	10
3	Interface	ASCII code	10
4	Font	ASCII code	10
5	Font download	ASCII code	10

5.13 DRIVER PROTOCOL (CONT'D)

(3) Form Overlay Status Request

In receiving this command, the form overlay status is responded.

- a) Command SOH (01H)+FO
- b) Responded Status Definition
STX + Form Overlay Registration contents + ETX
- c) Status Byte Definition

No.	Item	Contents	Byte number
1	Registration number	01 (ASCII code)	2
2	Registration name	Registration name (ASCII code)	16

(4) Font Configuration Status request

In receiving this command, the printer font data is echoed.

- a) Command SOH (01H) + FG
- b) Responded Status Definition
STX + the following echo statuses (The echo byte number changes depending on the font number) + ETX

c) Status Byte Definition

No.	Item	Contents	Byte number
1	Font ID number	ASCII code specification	2
2	Logo /Character selection	0: Character 1: Logo	2
3	Font name	ASCII code specification	32
4	Font Style (character decoration)	ASCII code specification	12
5	Font size (points)	ASCII code specification	4
6	Character width	Dot specification (binary code)	2
7	Character height	Dot specification (binary code)	2
8	Font size (1 character byte)	Dot specification (binary code)	4
9	Font registration number	Binary code specification	4
10	Font data top address	Binary code	4
11	Total size	Binary code	4
12	Vertical writing flag	Vertical / Horizontal writing	2
13	Character pitch	Fixed pitch / variable pitch	1
14	Family	Family attribute	1
15	Character set	Character set	1
16	Italic	Italic attribute	1
17	Weight	Emphatic attribute	2
18	Average character width	Dot specification	2
19	Accent	Dot specification	2
20	Registration start code	1 byte character registration start code	2
21	Registration end code	1 byte character registration end code	2
22	Reserved		8
23	Code 1	Binary code	2
24	Horizontal valid size 1	Binary code	2
25	Left gap size 1	Binary code	2
*	*	*	*
*	*	*	*
*	Code ??	Binary code	2
*	Horizontal valid size??	Binary code	2
*	Left gap size??	Binary code	2

5.13 DRIVER PROTOCOL (CONT'D)

4) Response sequence

(1) Normal

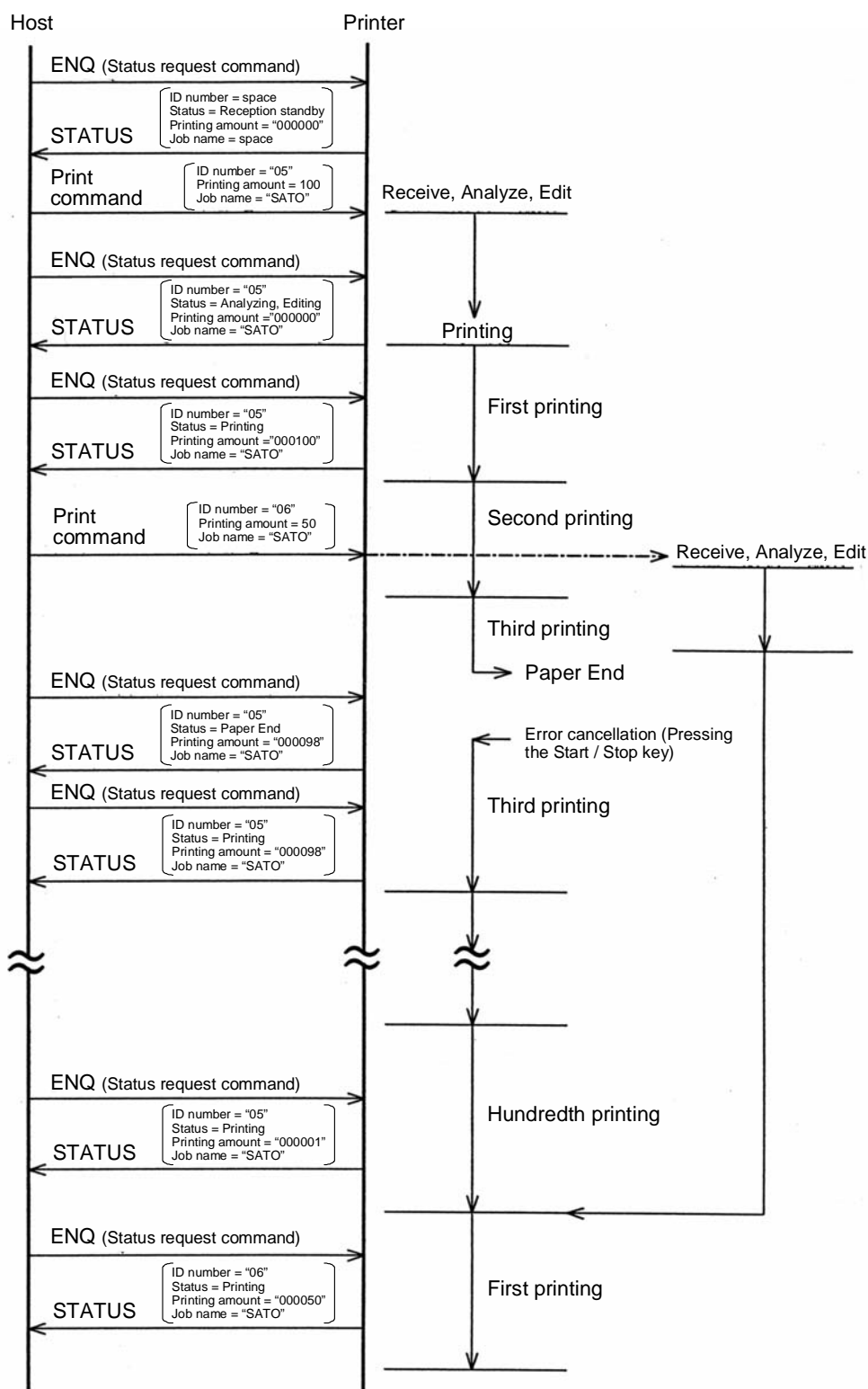

5.13 DRIVER PROTOCOL (CONT'D)

(2) Cancel request command

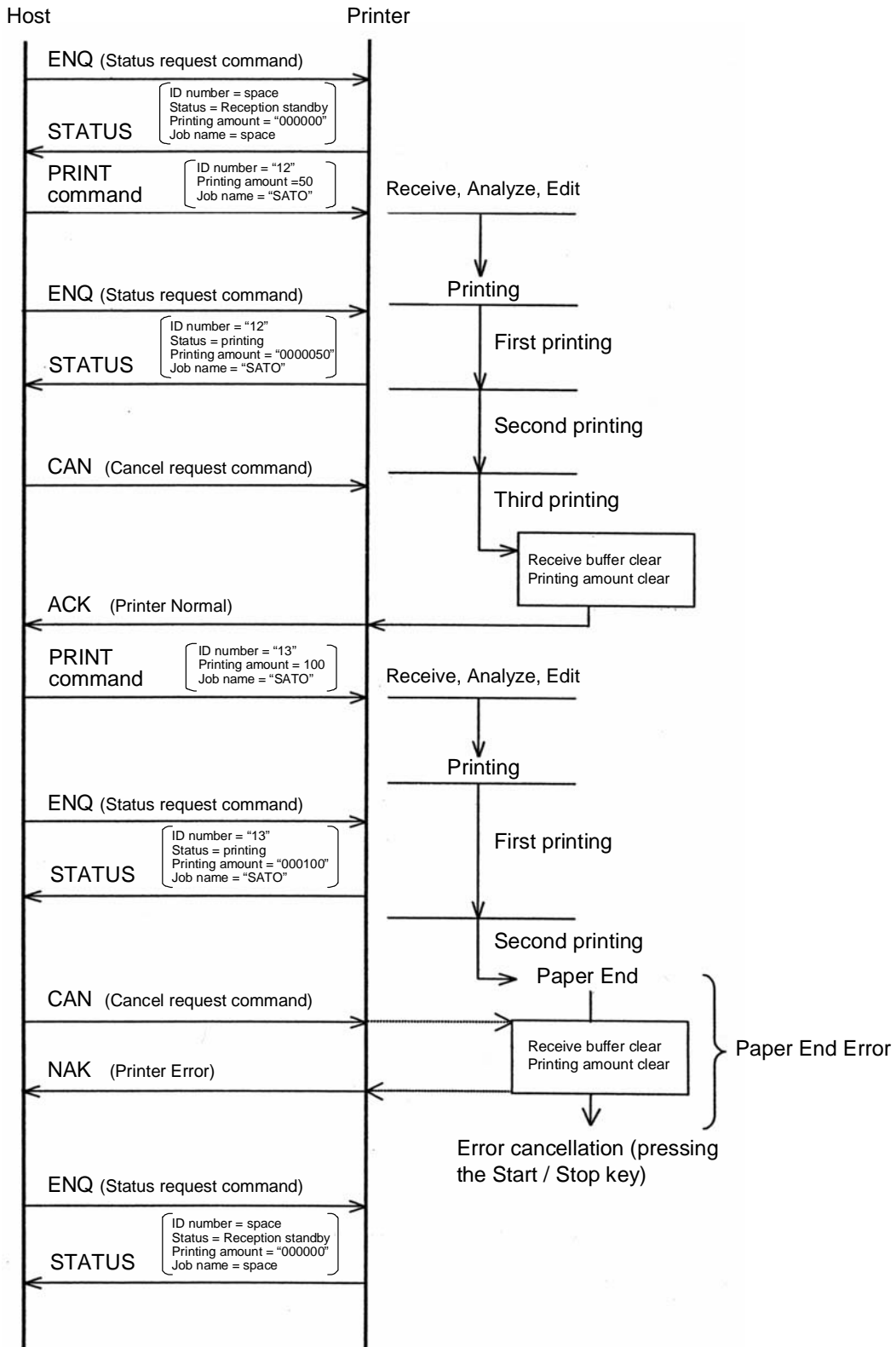

5.14 STATUS 3

This transmission protocol responds the status from the printer using requested commands from the host and targets printer status control in the host.

Furthermore, the status is sent immediately after the request command has been received.

The data received cannot be guaranteed when Print data (ESC+"A" - ESC+"Z") is sent from the host under the following conditions:

- 1) When the printer is OFFLINE
- 2) When an error occurs in the printer

Pin Assignments

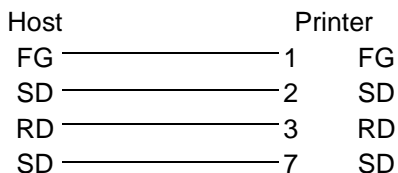

Caution!

In the connections, it may be necessary to loop (usually kept "High) CS and RS on the host side depending on the type of host. Therefore, make sure to re-check the host before use.

Input Output Signals

Pin no.	Signal Type	Direction	Contents
1	FG	-	Frame Ground
2	SD	Output	Send Data
3	RD	Input	Receive Data
7	SG	-	Signal Ground

5.15 MULTI JOB BUFFER

Timing Chart — Normal Processing

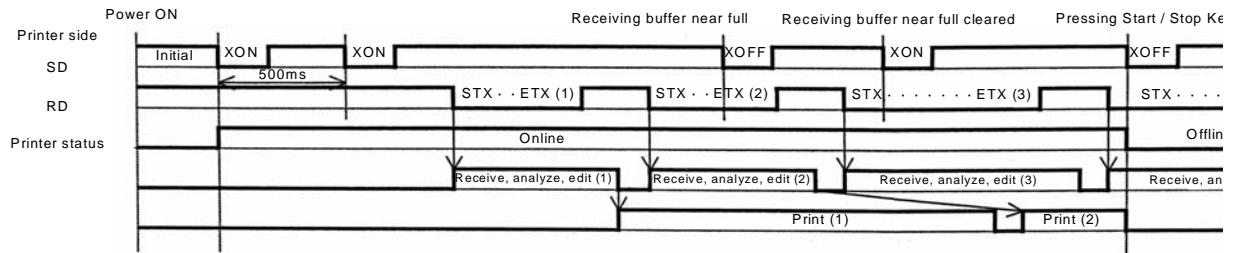

Note: This protocol will execute an "XON" polling at an interval of 500ms, from the moment the power is turned on until the receipt

Timing Chart — Cancel Process

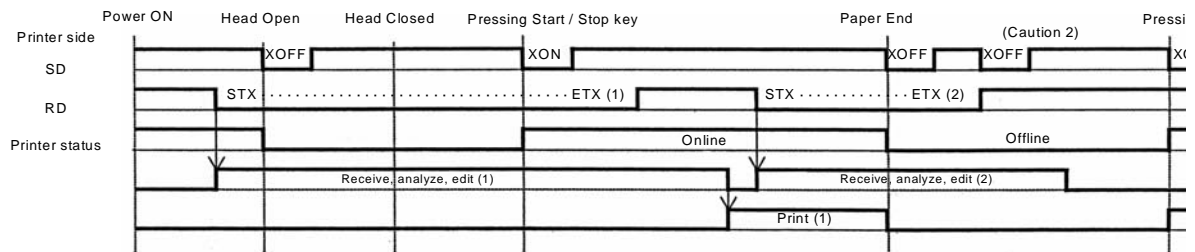

Note: Paper End will be cleared when the Head has been closed.
 Note 2: An "XOFF" transmission will be executed when receiving data during the occurrence of an error.

5.15 MULTI JOB BUFFER (CONT'D)

Timing Chart — Normal Processing

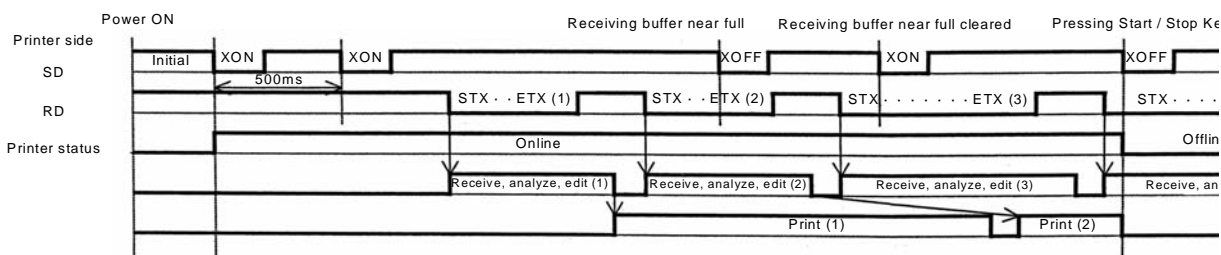

Note: This protocol will execute an "XON" polling at an interval of 500ms, from the moment the power is turned on until the receipt

Timing Chart — Cancel Process

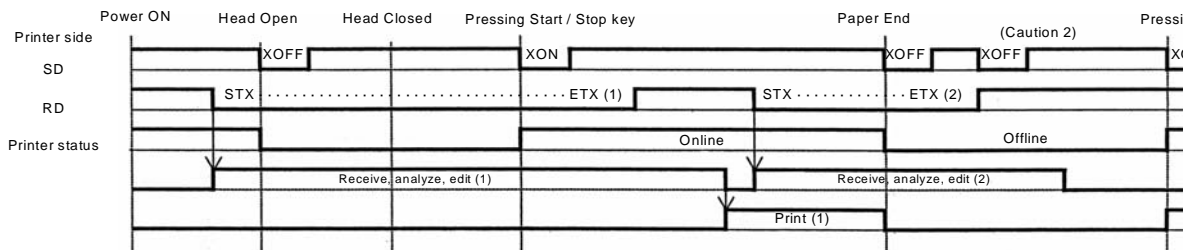

Note: Paper End will be cleared when the Head has been closed.
 Note 2: An "XOFF" transmission will be executed when receiving data during the occurrence of an error

5.15 MULTI JOB BUFFER (CONT'D)

Timing Chart — Error Processing

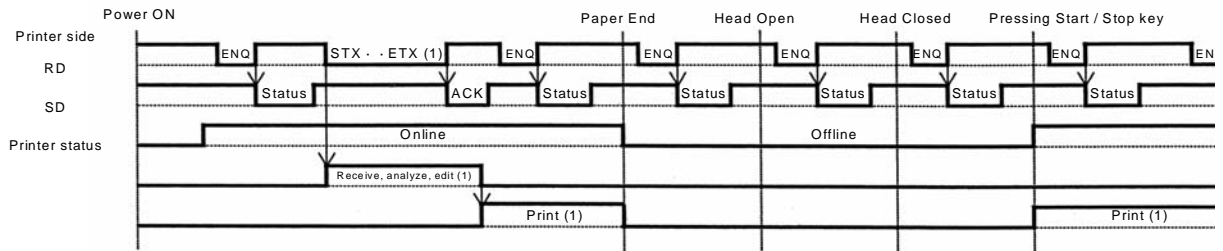

5.15 MULTI JOB BUFFER (CONT'D)

Status Response

This transmission protocol responds to the host, the printer's condition or response as a status by receiving 2 types of printing or requested commands. The details of each request or echo command are explained below.

(1) Status Request Command

In receiving this command, the ID number of received data currently being printed and the printer's condition, as well as the remaining number of print jobs and their names are responded to the host. Furthermore, after printing or if no data has been received, or if the ID command has not be specified, the ID number will be echoed back as spaces (Hex 20H), and the quantity of print jobs will be responded back as all zeroes (Hex 30H).

- i) Command ENQ (Hex 05H)
- ii) Responded Status Definition

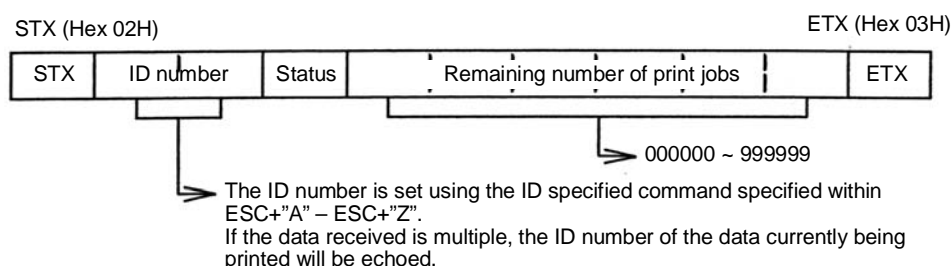

iii) Status List

Contents		ASCII	Hex	
Offline	No errors	0	30	
	Ribbon near end	1	31	
	Buffer near full	2	32	
	Ribbon near end and buffer near full	3	33	
Online	Reception Standby	No errors	A	41
		Ribbon near end	B	42
		Buffer near full	C	43
		Ribbon near end and buffer near full	D	44
	Printing	No errors	G	47
		Ribbon near end	H	48
		Buffer near full	I	49
		Ribbon near end and buffer near full	J	4A
	Standby (dispenser cut standby)	No errors	M	4D
		Ribbon near end	N	4E
		Buffer near full	O	4F
		Ribbon near end and buffer near full	P	50
Analyzing / Editing	No errors	S	53	
	Ribbon near end	T	54	
	Buffer near full	U	55	
	Ribbon near end and Buffer near full	V	56	
Error detection	Head open	b	62	
	Paper End	c	63	
	Ribbon end	d	64	
	Media error	e	65	
	Sensor error	f	66	
	Head error	g	67	
	Card error	i	69	
	Cutter error	j	6A	
	Other errors	k	6B	
	Cutter sensor error	l	6C	
Stacker Full	m	6D		

5.15 MULTI JOB BUFFER (CONT'D)

(2) Cancel Request Command

In receiving this command, printing is aborted and the contents of the reception buffer are completely cleared.

The status responded is the status of the printer after this procedure has been completed. After sending the cancel request command, the next data should be sent after a lapse of more than 100ms.

- i) Command CAN (Hex 18H)
- ii) Responded Status Definition

Echo Status	Contents
ACK (Hex 06H)	Indicates that there is no printer error
NAK (Hex 15H)	Indicates that there is a printer error

(3) Print command

In receiving the printing command (ESC+"A" – ESC+"Z"), printing commences.

The status echoed is the status of the printer after the receiving process has been completed.

- i) Responded Status Definition

Echo Status	Contents
ACK (Hex 06H)	Indicates that there is no printer error
NAK (Hex 15H)	Indicates that there is a printer error

5.15 MULTI JOB BUFFER (CONT'D)

3) Echo sequence

(1) Normal

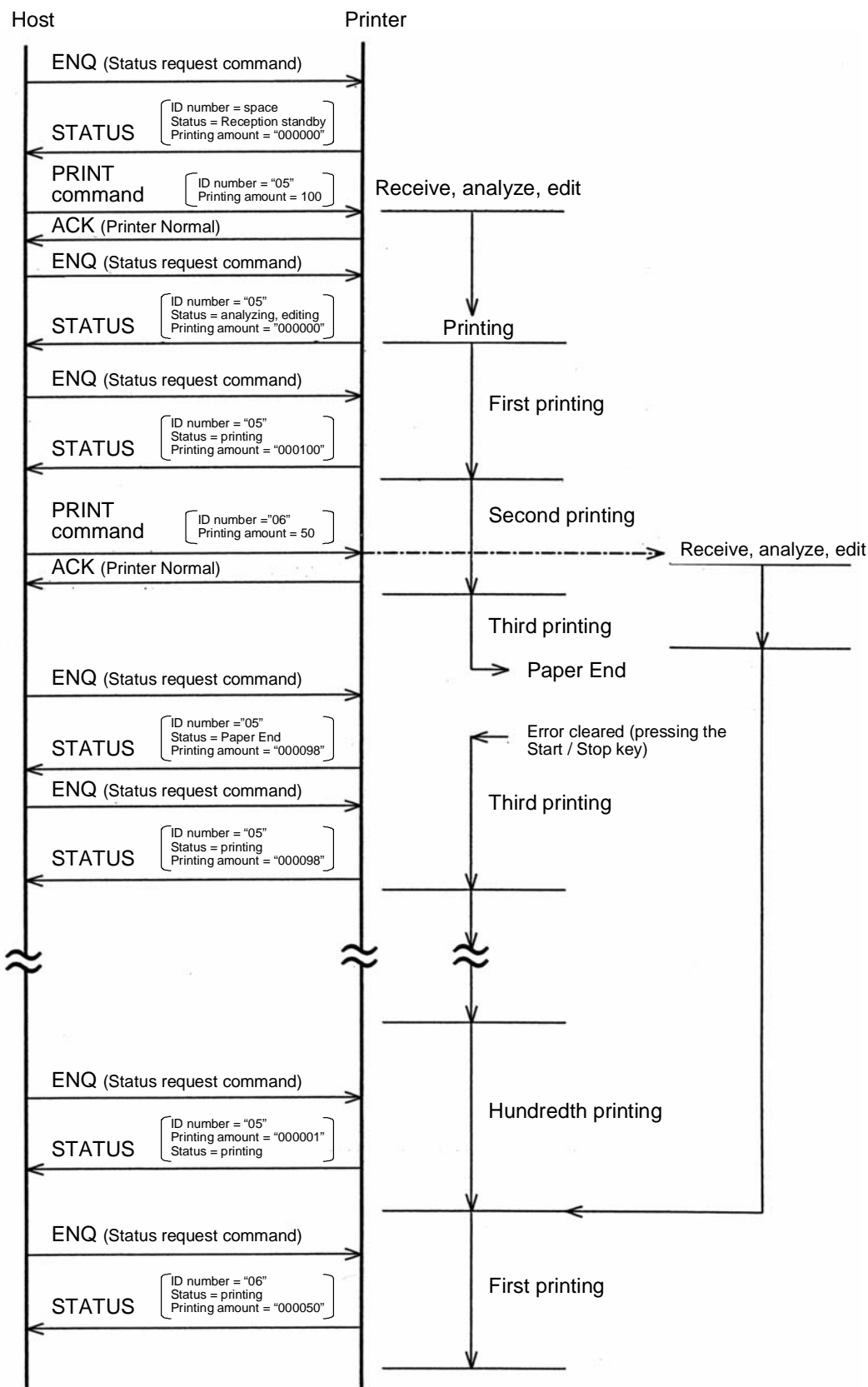

5.15 MULTI JOB BUFFER (CONT'D)

3) Echo sequence (2) Cancel Request Command

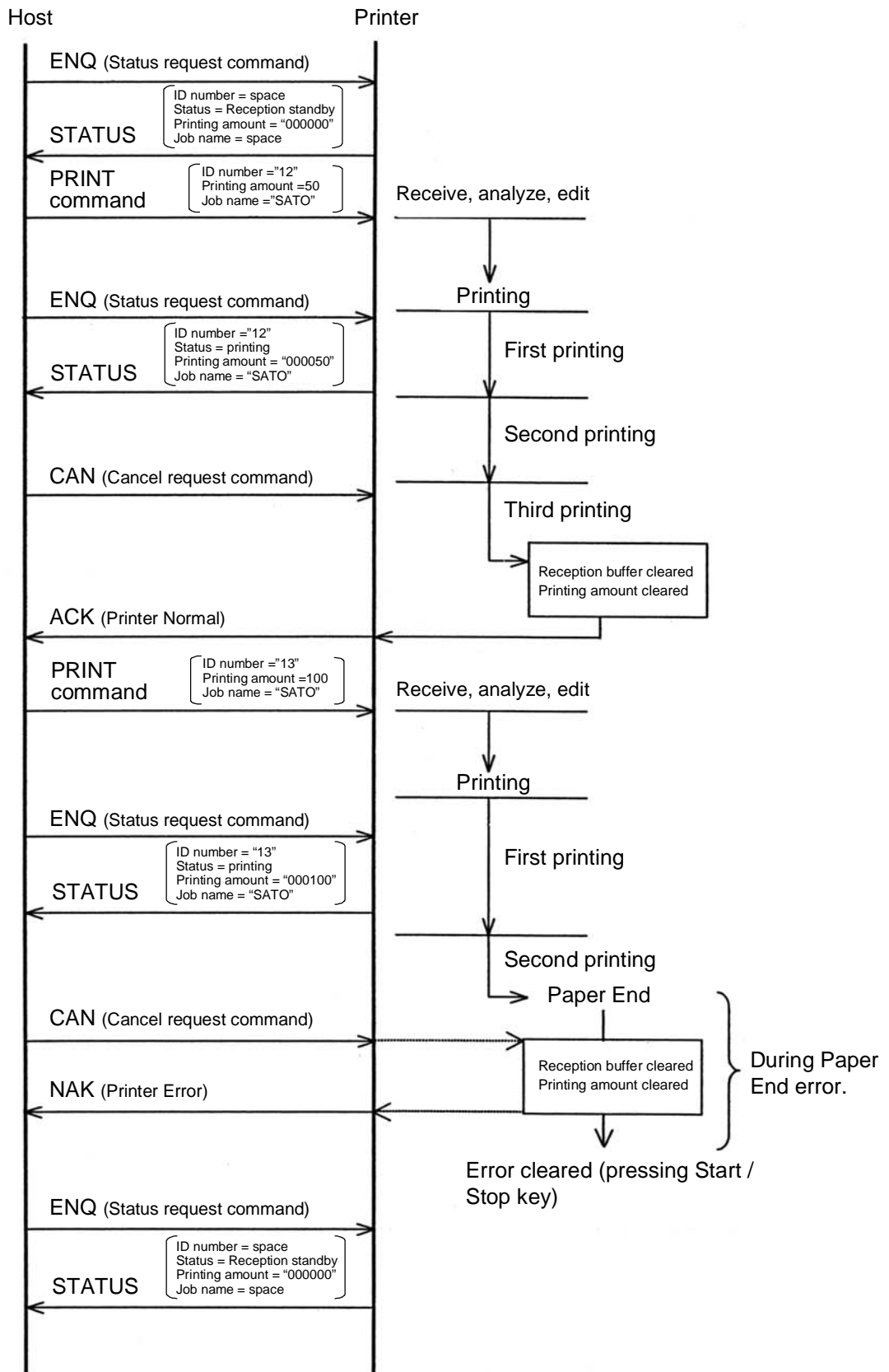

5.16 REFERENCE FLOWCHART

When creating a program on the host side under this protocol, refer to the following flowchart.

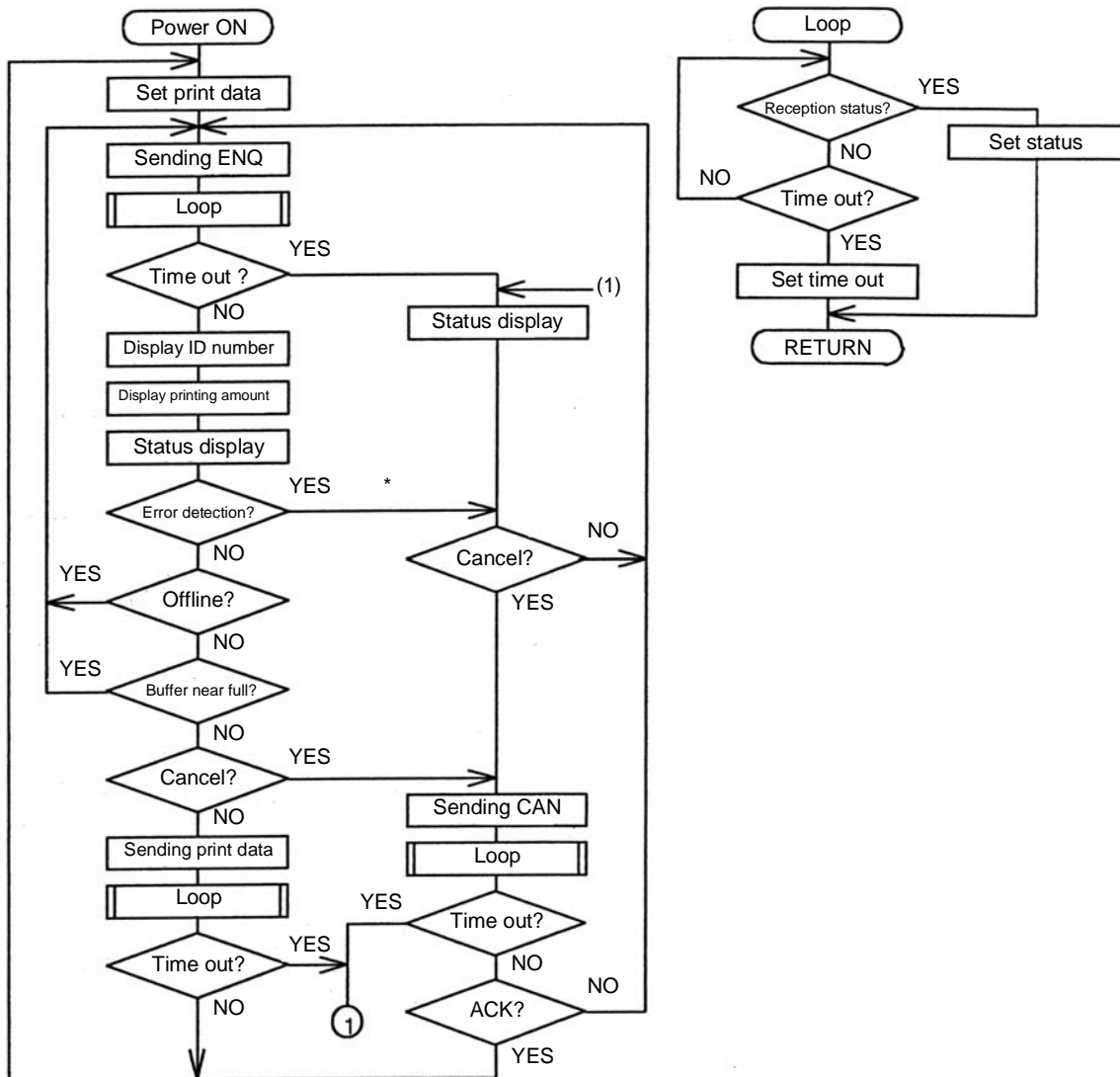

Note:

In the event that an error is detected in the printer status, make sure to send the following data after clearing the error using ENQ.

5.17 PARALLEL INTERFACE SPECIFICATIONS (CENTRONICS)

The parallel interface of this printer conforms to Centronics standards.

Basic Specifications

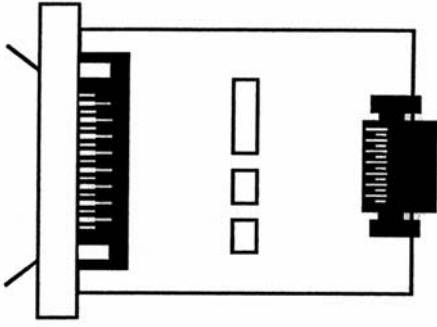
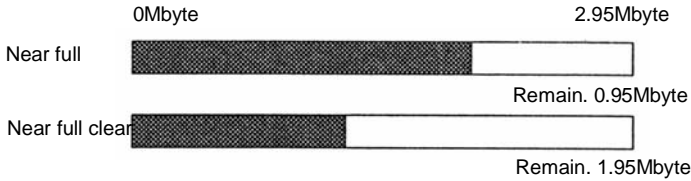
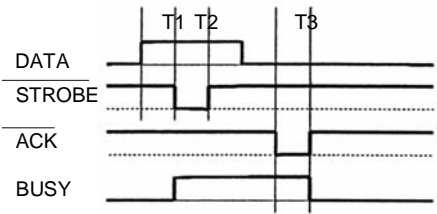
Interface board								
Connector	Printer Cable Cable length	Amphenol (DDK) 57 to 40360 (Equivalent) Amphenol (DDK) 57 to 30360 (Equivalent) Under 3 meters						
Signal level	High level Low level	: + 2.4 to + 5.0 V : - 0.0 to - 0.4 V						
Communication settings	One item or Multi communication can be selected using DSW2-5. <table border="1" data-bbox="663 1090 1169 1196"> <thead> <tr> <th>DIPSW2-5</th> <th>Set Range</th> </tr> </thead> <tbody> <tr> <td>ON</td> <td>Multi-reception</td> </tr> <tr> <td>OFF</td> <td>One Item</td> </tr> </tbody> </table>		DIPSW2-5	Set Range	ON	Multi-reception	OFF	One Item
DIPSW2-5	Set Range							
ON	Multi-reception							
OFF	One Item							
Maximum Reception buffer capacity	2.95Mbyte 							
Timing chart	 <p data-bbox="686 1747 845 1803">* 1μs < T1, T2 7μs < T3 < 9μs</p>							

5.17 PARALLEL INTERFACE (CONT'D)

Pin Assignments

Pin no.	Signal Type	Contents	Pin no.	Signal Type	Contents
1	nSTROBE	Input	19	STROBE-RETURN	
2	DATA 1	Input	20	DATA 1 - RETURN	
3	DATA 2	Input	21	DATA 2 - RETURN	
4	DATA 3	Input	22	DATA 3 - RETURN	
5	DATA 4	Input	23	DATA 4 - RETURN	
6	DATA 5	Input	24	DATA 5 - RETURN	
7	DATA 6	Input	25	DATA 6 - RETURN	
8	DATA 7	Input	26	DATA 7 - RETURN	
9	DATA 8	Input	27	DATA 8 - RETURN	
10	nACK	Output	28	ACK - RETURN	
11	BUSY	Output	29	BUSY - RETURN	
12	PE	Output	30	PE - RETURN	
13	SELECT	Output	31		
14			32	nFAULT	Output
15			33		
16			34		
17	FG	Frame Ground	35		
18	24Ω (+5V)		36		

Interface Signals

Pin no.	Signal Type	Direction	Contents
1	nSTROBE	Input	To scan data, make sure that the pulse width of the strobe pulse is set to more than 1 μs. The regular status is "High", however, if it is "Low", the data will be scanned in the first transition.
2 to 9	DATA 1 to DATA 8	Input	DATA1=LSB DATA8=MSB Positive logic code ASCII or JIS7 as well as 8.
10	nACK	Output	A low level pulse signal will be output when data scanning is complete to inform the host.
11	BUSY	Output	"High" will be maintained when the Reception buffer has reached full or when an error occurs in the printer, and "Low" will be output when the printer is ready to receive.
12	PE	Output	The level will become "High" when labels have run out and none have been set.
13	SELECT	Output	The signal will be in "High" level when reception is possible, otherwise it will be "Low" level.
32	nFAULT	Output	The signal will be in "High" level when reception is possible, otherwise it will be "Low" level.

5.18 SINGLE JOB BUFFER

Timing Chart — Normal Processing

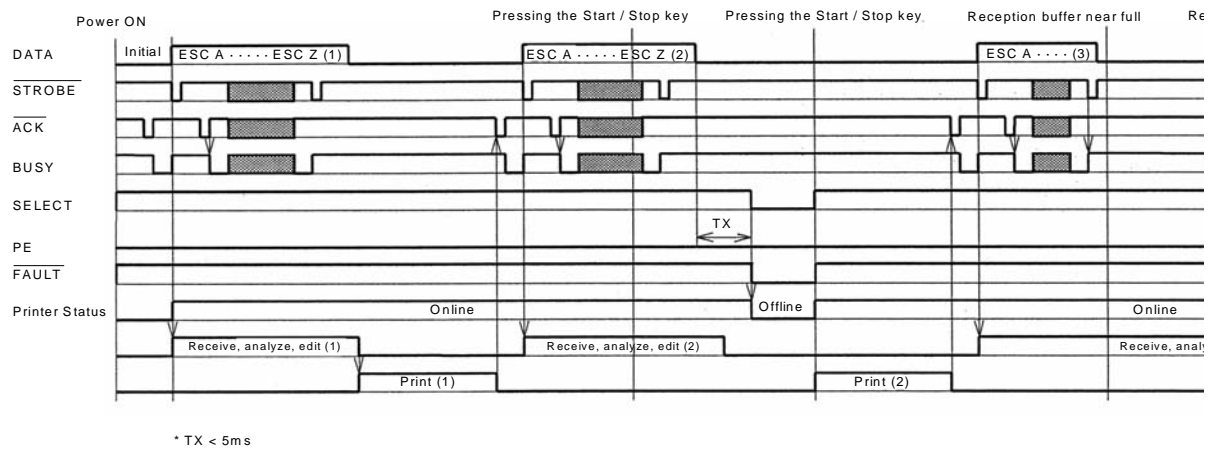

Timing Chart — Procedure during Paper End

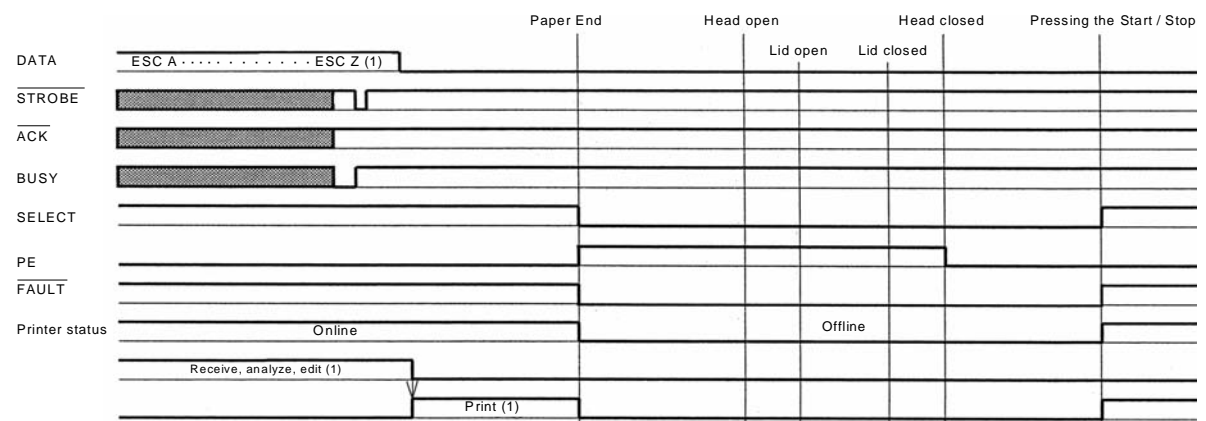

Note: Paper End is cleared by closing the Head.

5.18 SINGLE JOB BUFFER (CONT'D)

Timing Chart — Error Processing

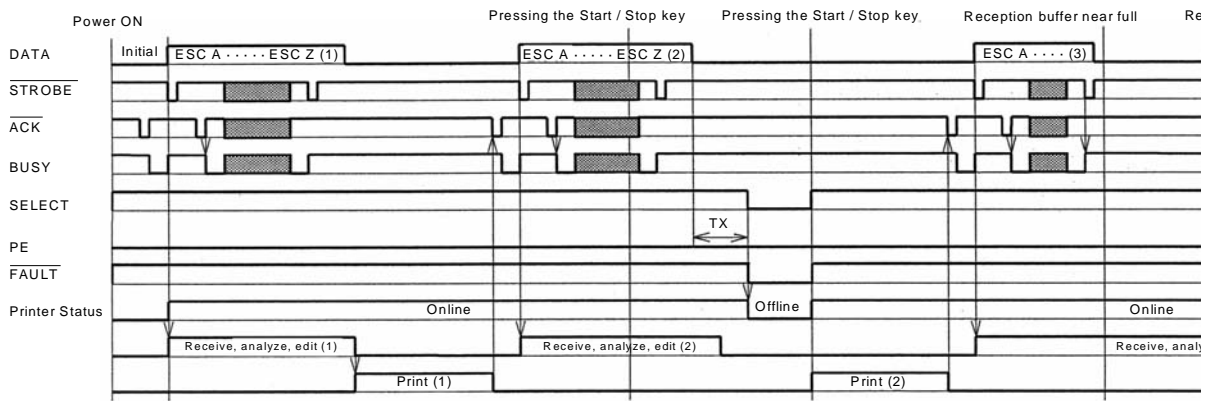

* TX < 5ms

5.19 MULTI JOB BUFFER

Timing Chart — Normal Processing

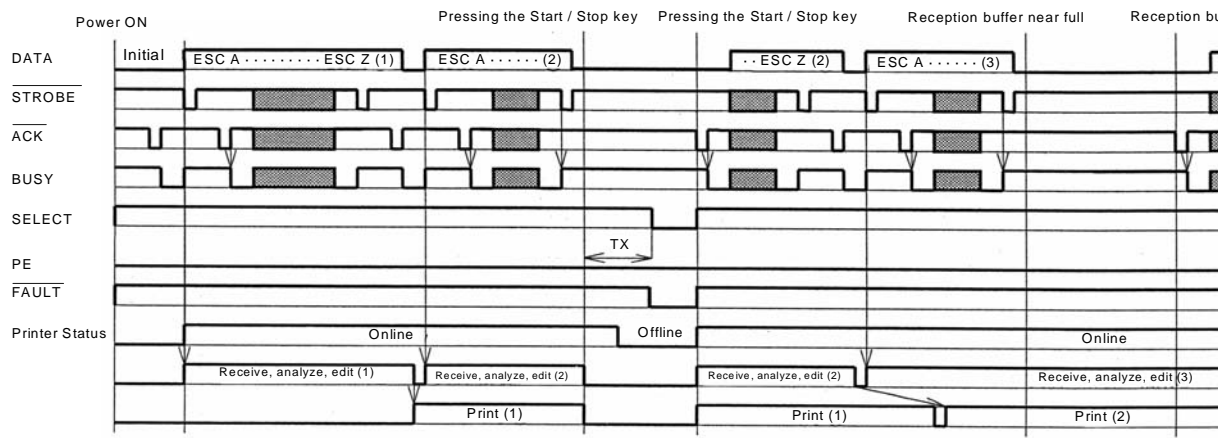

* TX < 5ms

5.19 MULTI JOB BUFFER (CONT'D)

Timing Chart — Procedure during Paper End

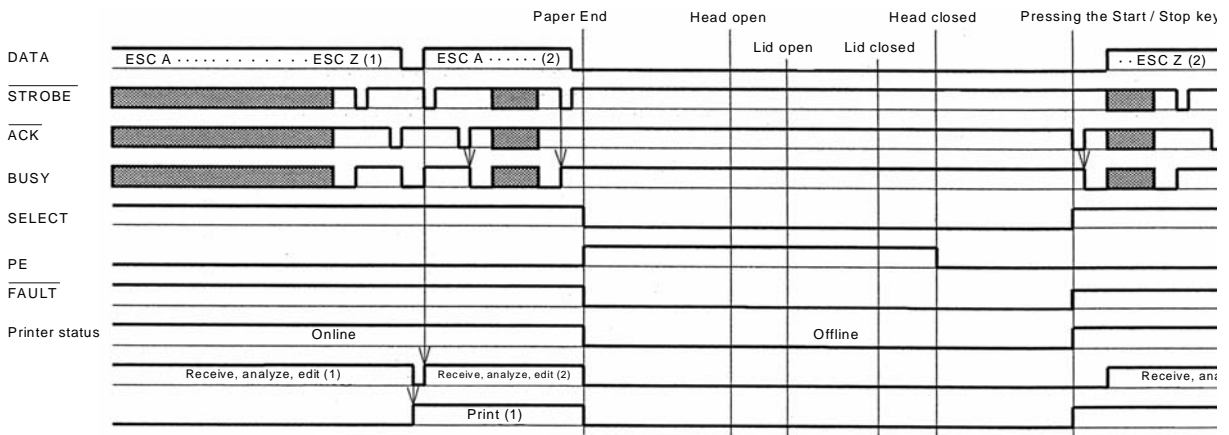

Caution! Paper End is cleared by closing the Head

5.19 MULTI JOB BUFFER (CONT'D)

Timing Chart — Error Processing

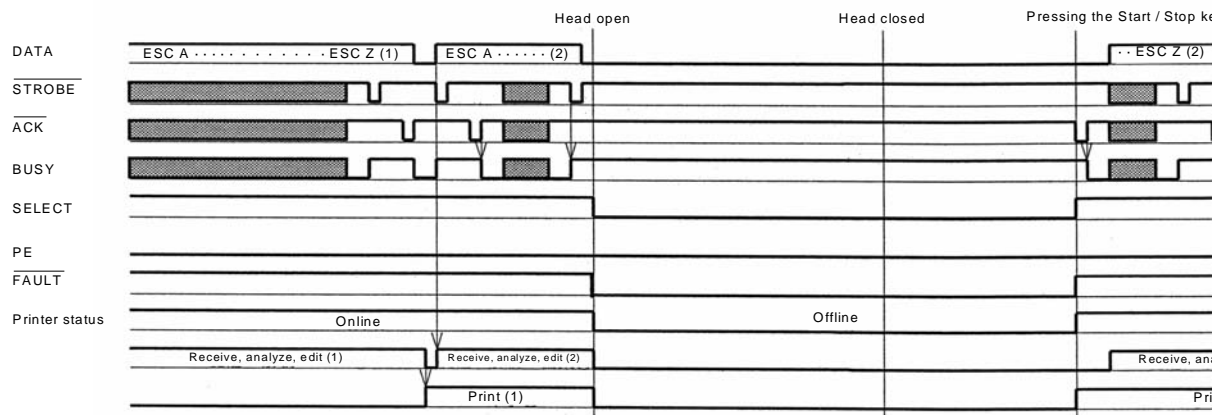









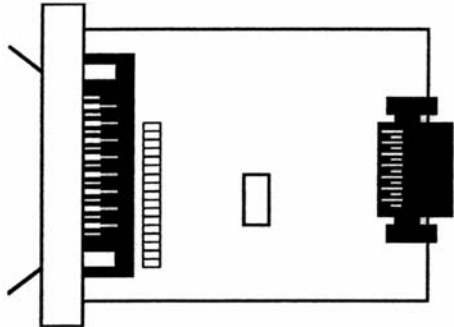
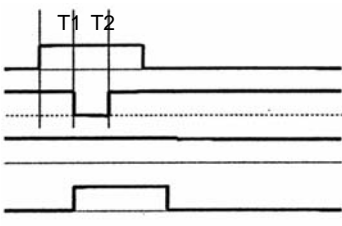
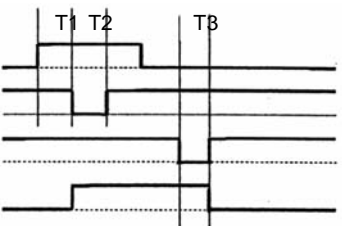

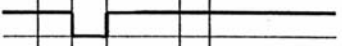
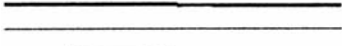
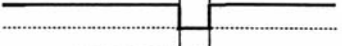
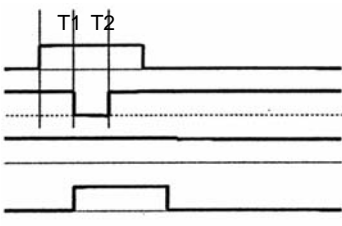
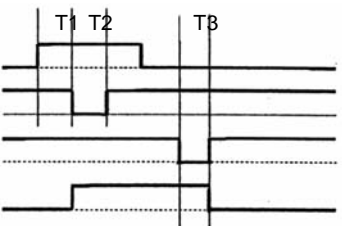

5.20 IEEE 1284 INTERFACE

The IEEE 1284 Interface on the printer complies with IEEE1284 standards.

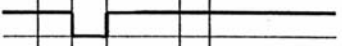
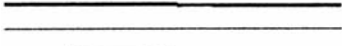
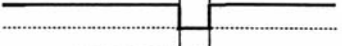
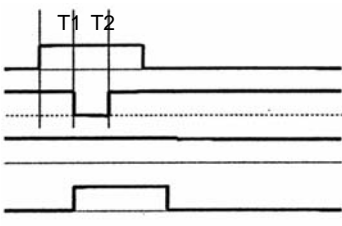
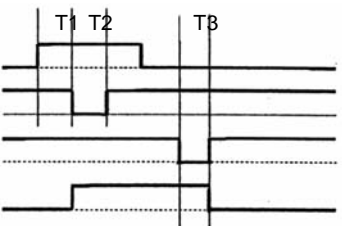
The ECP mode is recommended for LPT1 port settings.
 Make sure to change the LPT1 port settings through the BIOS settings.

Basic Specifications

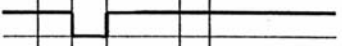
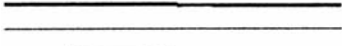
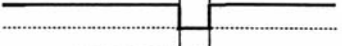
Interface board																
Connector	Printer Amphenol (DDK) 57 to 40360 (Equivalent) Cable Amphenol (DDK) 57 to 30360 (Equivalent) Cable length Under 3 meters															
Signal level	High level : + 2.4 to + 5.0 V Low level : - 0.0 to - 0.4 V															
Communication settings	One item or Multi communication can be selected using DSW2-5. <table border="1" data-bbox="592 1122 1114 1234" style="margin-left: auto; margin-right: auto;"> <thead> <tr> <th>DIPSW2-5</th> <th>Set Range</th> </tr> </thead> <tbody> <tr> <td>ON</td> <td>Multi-reception</td> </tr> <tr> <td>OFF</td> <td>One Item</td> </tr> </tbody> </table>	DIPSW2-5	Set Range	ON	Multi-reception	OFF	One Item									
DIPSW2-5	Set Range															
ON	Multi-reception															
OFF	One Item															
Maximum Receive buffer capacity	2.95Mbyte <div style="margin-left: 40px;"> <p style="margin-left: 80px;">Near full 0Mbyte 2.95Mbyte</p> <p style="margin-left: 80px;">Near full clear 0Mbyte 1.95Mbyte</p> <p style="margin-left: 120px;">Remain. 0.95Mbyte</p> <p style="margin-left: 120px;">Remain. 1.95Mbyte</p> </div>															
Timing chart	<table style="width: 100%; border-collapse: collapse;"> <thead> <tr> <th></th> <th style="text-align: center;">ECP mode</th> <th style="text-align: center;">Centronics compatible mode</th> </tr> </thead> <tbody> <tr> <td style="text-align: right;">DATA</td> <td style="text-align: center;"></td> <td style="text-align: center;"></td> </tr> <tr> <td style="text-align: right;">STROBE</td> <td style="text-align: center;"></td> <td style="text-align: center;"></td> </tr> <tr> <td style="text-align: right;">ACK</td> <td style="text-align: center;"></td> <td style="text-align: center;"></td> </tr> <tr> <td style="text-align: right;">BUSY</td> <td style="text-align: center;"></td> <td style="text-align: center;"></td> </tr> </tbody> </table> <p style="margin-left: 40px;"> * $1\mu\text{s} < T1, T2$ * $0.6\mu\text{s} < T3 < 1.2\mu\text{s}$ * It is possible to set the ACK width settings (0.5 – 10 μs) in the Advanced mode, in the case of One Item reception. </p>		ECP mode	Centronics compatible mode	DATA			STROBE			ACK			BUSY		
	ECP mode	Centronics compatible mode														
DATA																
STROBE																
ACK																
BUSY																

5.20 IEEE 1284 INTERFACE (CONT'D)

Pin Assignment

Make sure to use a IEEE1284 compliant cable

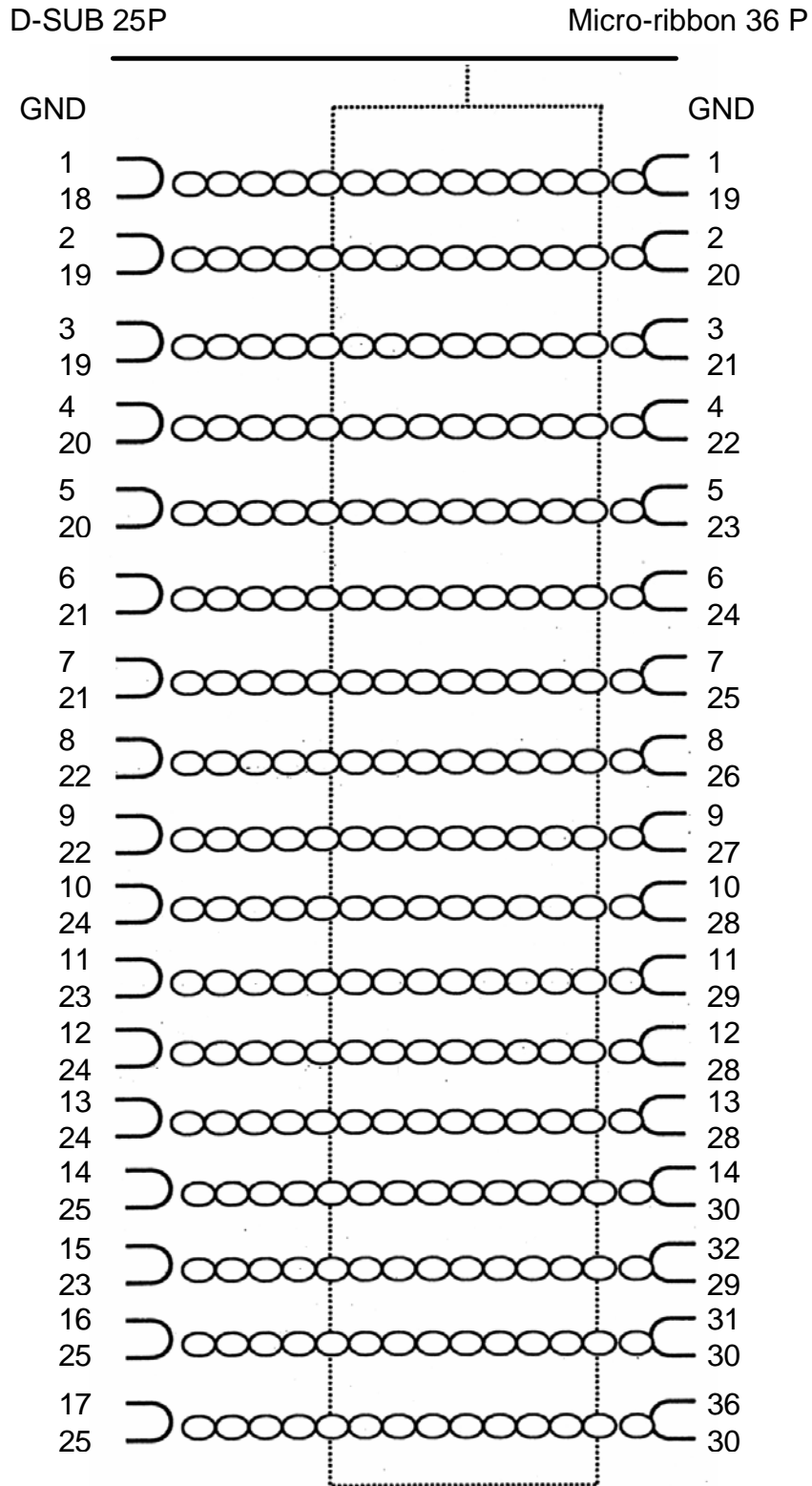

5.20 IEEE 1284 INTERFACE (CONT'D)

Pin Assignment

With Centronics standards, each signal pin placement is as follows:

However, the IEEE 1284-B type connector is compliant when connecting the IEEE1284 standard.

Pin no.	Signal Type	Content	Pin no.	Signal Type	Content
1	HOST CLK	Input	19	SIGNAL GROUND	
2	DATA 1	Input	20	SIGNAL GROUND	
3	DATA 2	Input	21	SIGNAL GROUND	
4	DATA 3	Input	22	SIGNAL GROUND	
5	DATA 4	Input	23	SIGNAL GROUND	
6	DATA 5	Input	24	SIGNAL GROUND	
7	DATA 6	Input	25	SIGNAL GROUND	
8	DATA 7	Input	26	SIGNAL GROUND	
9	DATA 8	Input	27	SIGNAL GROUND	
10	PERIPH CLK	Output	28	SIGNAL GROUND	
11	PERIPH ACK	Output	29	SIGNAL GROUND	
12	nACK REVERSE	Output	30	SIGNAL GROUND	
13	XFLAG	Output	31	NREVERSE REQUEST	Input
14	HOST ACK	Input	32	nPERIPH REQUEST	Output
15			33		
16	LOGIC GND		34		
17	CHASSIS GND		35		
18	PERIPHERAL LOGIC HIGH	Input	36	1284ACTIVE	Input

5.21 INTERFACE SIGNALS

With Centronics standards, the content of each signal type is as follows. However, each signal line used with IEEE1284 standards is compliant with IEEE1284 standards.

Pin no.	Signal Type	Direction	Contents
1	HOST CLK	Input	A low active pulse is necessary in synchronized signals for scanning Data 1 to Data 8.
2 to 9	DATA 1 to DATA 8	Input	When entering 8 bit parallel Data, Data 1 is the LSB (least significant bit) and Data 8 is the MSB (most significant bit)
10	PERIPH CLK	Output	This is the LOW active pulse signal that indicates the completion of received data scanning.
11	PERIPH ACK	Output	HIGH active signal which indicates that the printer cannot receive data.
12	nACK REVERSE	Output	HIGH active signal which indicates that the media has run out.
13	XFLAG	Output	HIGH active signal which indicates that data can be received.
14	HOST ACK	Input	Signal for when using the IEEE1284 standard.
17	CHASSIS GND		Connects to the Frame Ground
18	PERIPHERAL LOGIC HIGH	Output	The +5V voltage on the printer side.
19 to 30	SIGNAL GROUND		Connects to the ground for each signal
31	nREVERSE REQUEST	Input	LOW active signal that requests printer initialization.
32	nPERIPH REQUEST	Output	LOW active pulse signal that indicates a printer error.
36	1284ACTIVE	Input	Signal for when using the IEEE1284 standard.

5.22 SINGLE JOB BUFFER

Timing Chart — Normal Processing

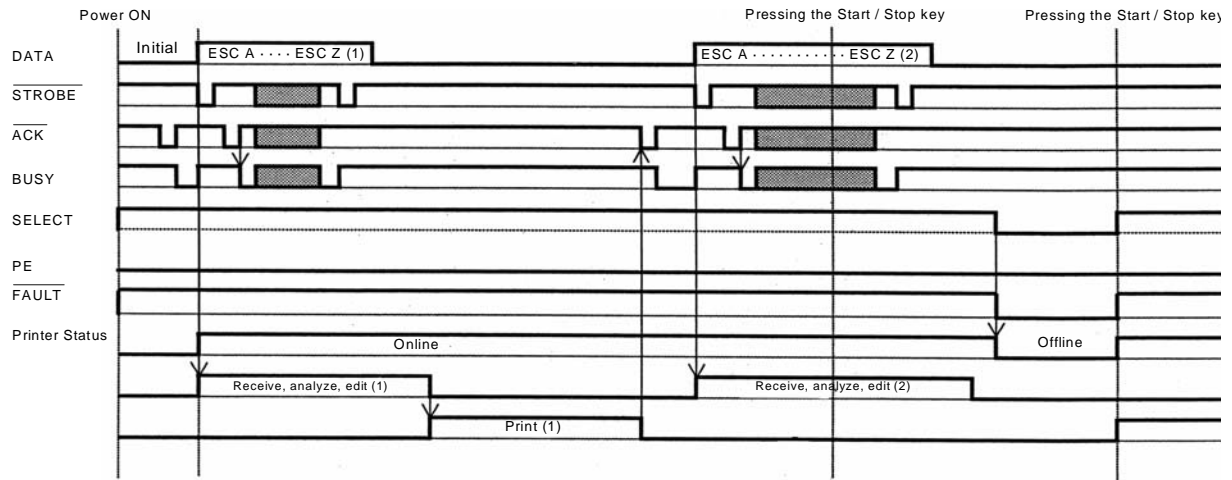

5.22 SINGLE JOB BUFFER (CONT'D)

Timing Chart — Procedure during Paper End

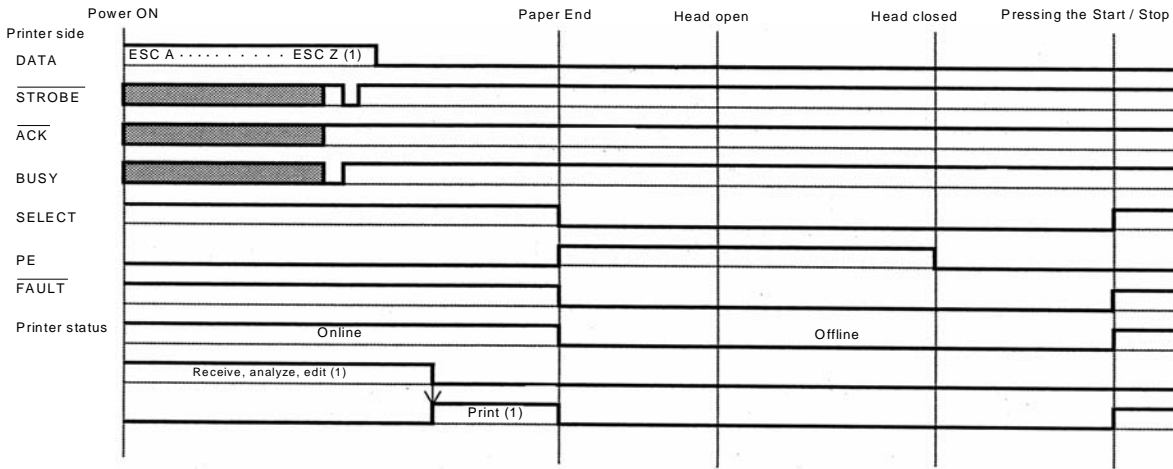

Note: Paper End is cleared by closing the Head.

5.23 MULTI JOB BUFFER

Timing Chart — Normal Process

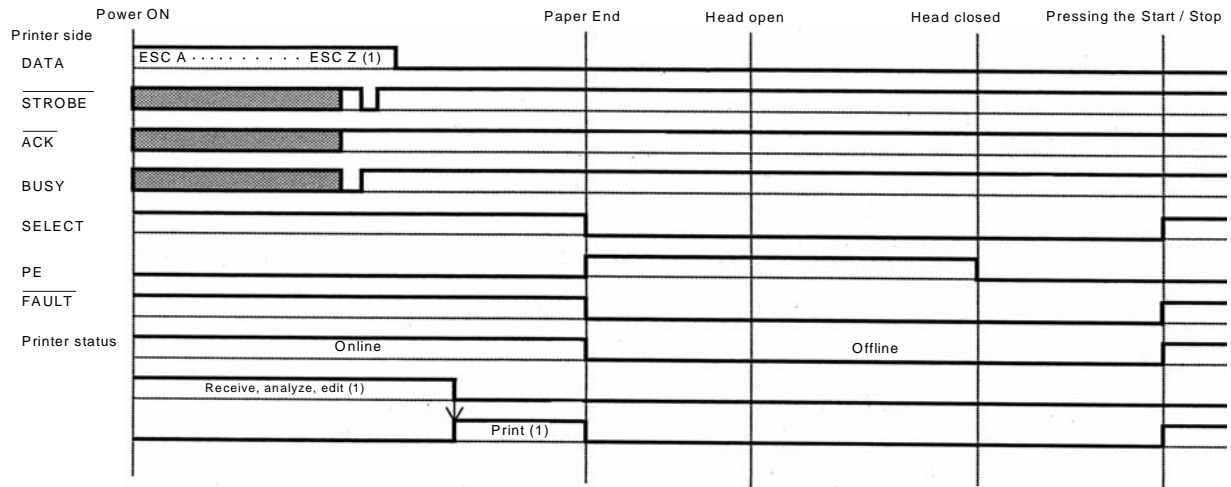

Note: Paper End is cleared by closing the Head.

5.23 MULTI JOB BUFFER (CONT'D)

Timing Chart — Procedure during Paper End

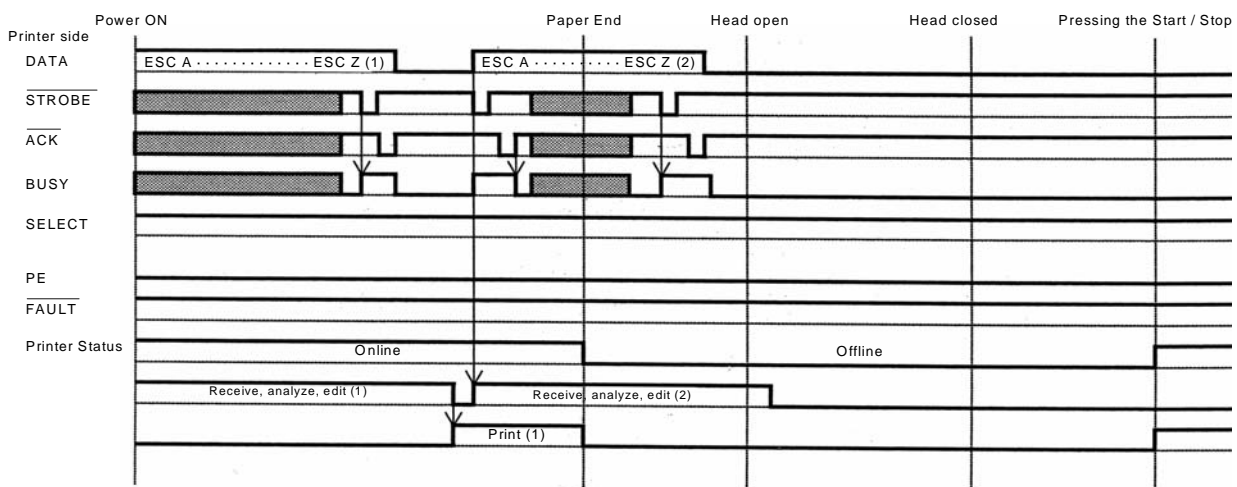

Note: Paper End is cleared by closing the Head

5.24 DRIVER PROTOCOL

This transmission protocol responds to the host, the printer's condition or response as a status by receiving 2 types of printing or requested commands.

The details of each request command or echo status are explained below.

1) Status Response

(1) Status Request Command

In receiving this command, the ID number of received data currently being printed and the printer's condition, as well as the remaining number of print jobs and their names are responded to the host. Furthermore, after printing or if no data has been received, or if the ID command has not be specified, the ID number will be responded back as spaces (Hex 20H), and the quantity of print jobs will be responded back as all zeroes (Hex 30H).

a) Command ENQ (Hex 05H)

b) Responded Status Definition

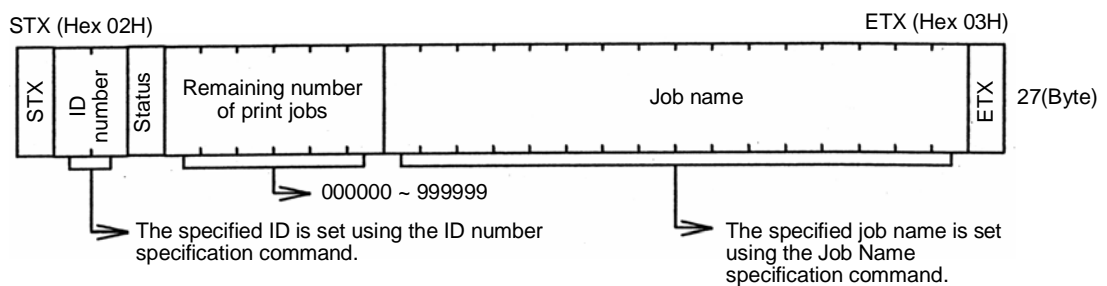

c) Echo Status List

Content		ASCII	Hex	
Offline	No errors	0	30	
	Ribbon near end	1	31	
	Buffer near full	2	32	
	Ribbon near end and buffer near full	3	33	
	Printing stopped (no errors)	4	34	
Online	Reception Standby	No errors	A	41
		Ribbon near end	B	42
		Buffer near full	C	43
		Ribbon near end and buffer near full	D	44
		Printing stopped (no errors)	E	45
	Printing	No errors	G	47
		Ribbon near end	H	48
		Buffer near full	I	49
		Ribbon near end and buffer near full	J	4A
		Printing stopped (no errors)	K	4B
	Standby (dispenser cut standby)	No errors	M	4D
		Ribbon near end	N	4E
		Buffer near full	O	4F
		Ribbon near end and buffer near full	P	50
		Printing stopped (no errors)	Q	51
	Analyzing / Editing	No errors	S	53
		Ribbon near end	T	54
		Buffer near full	U	55
		Ribbon near end and Buffer near full	V	56
		Printing stopped (no errors)	W	57
Error detection	Head open	b	62	
	Paper End	c	63	
	Ribbon end	d	64	
	Media error	e	65	
	Sensor error	f	66	
	Head error	g	67	
	Card error	i	69	
	Cutter error	j	6A	
	Other errors	k	6B	
	Cutter sensor error	l	6C	
	Stacker Full	m	6D	

5.24 DRIVER PROTOCOL (CONT'D)

(2) Cancel Request Command

In receiving this command, printing is stopped and the contents of the reception buffer are all cleared.

The status responded is the status of the printer after this procedure has been completed.

After sending the cancel request command, the next data should be sent after a lapse of more than 100ms.

- a) Command CAN (Hex 18H)
- b) Status Byte Definition

Echo Status	Contents
ACK (Hex 06H)	Indicates that there is no printer error
NAK (Hex 15H)	Indicates that there is a printer error

(3) Print Stop Request

In receiving this command, printing is stopped.

The status responded is the status of the printer after reception has been completed

- a) Command DLE (Hex 10H)

b) Status Byte Definition

Status	Contents
ACK (Hex 06H)	Indicates that there is no printer error
NAK (Hex 15H)	Indicates that there is a printer error

(4) Print Start Request

In receiving this command, Print Stop is cleared and the printer commences printing. The status responded is the status of the printer after reception has been completed.

a) Command DC1 (Hex 11H)

b) Status Byte Definition

Status	Contents
ACK (Hex 06H)	Indicates that there is no printer error
NAK (Hex 15H)	Indicates that there is a printer error

5.24 DRIVER PROTOCOL (CONT'D)

2) Other Status responses

(1) Operating Status request

In receiving this command, the printer settings are responded to the host.

a) Command SOH (01H) + MG

b) Responded Status Definition

STX + the following Status (30 bytes) + ETX

c) Status Byte Definition

No.	Item	Contents	Byte no.
1	Printing method	00H: Thermal transfer 01H: Thermal	1
2	Head Density	00H: 200 (dpi) 8 (rolls/mm) 01H: 300 (dpi) 12 (rolls/mm)	1
3	Printing speed	02H: 4 (inch/s) 100 (mm/s) 03H: 5 (inch/s) 125 (mm/s) 04H: 6 (inch/s) 150 (mm/s) 05H: 7 (inch/s) 175 (mm/s) 06H: 8 (inch/s) 200 (mm/s)	1
4	Printing	00H: Consecutive 02H: Cutter	1
5	Print Area Expansion	00H: Standard 01H: Expanded	1
6	Reserved		1
7	Reserved		1
8	Print Darkness	Range A(41H): A B (42H): B C (43H): C D (44H): D E (45H): E F (46H): F Darkness 00H: 1 01H: 2 02H: 3	2
9	Sensor type	03H: Sensor hole 04H: Side hole 05H: R-Corner 06H: Reflective sensor (I- mark) 07H: Transparent sensor (Gap) 08H: Reflective sensor (I- mark) 09H: Sensor inactive	1

5.24 DRIVER PROTOCOL (CONT'D)

c) Status Byte Definition (Continued)

No.	Item	Contents	Byte no.
10	Zero Slash	00H: Inactive 01H: Active	1
11	Reserved		1
12	Reserved		1
13	Reserved		1
14	Character Gap	00H: Fixed pitch 01H: Proportional pitch	1
15	Vertical label size	Maximum vertical label size may change depending on the printer.	2
16	Horizontal label size	Maximum horizontal label size may change depending on the printer.	2
17	Vertical base reference point offset	00H – 3C0H (0 – 960 dots)	2
18	Horizontal base reference point offset	00H – 3C0H (0 – 960 dots)	2
19	Reserved		1
20	Reserved		1
21	Reserved		1
22	Reserved		1
23	Reserved		1
24	Reserved		1
25	Buzzer settings	00H : Enabled 01H : Disabled	1

(2) System Version Data Request

In receiving this command, the printer system version information is echoed.

- a) Command SOH (01H) + SB
- b) Responded Status Definition
STX + Printer System Version + ETX
- c) Status Byte Definition

No.	Item	Contents	Byte number
1	Operating system	ASCII code	10
2	Printer firmware	ASCII code	10
3	Interface	ASCII code	10
4	Font	ASCII code	10
5	Font download	ASCII code	10

5.24 DRIVER PROTOCOL (CONT'D)

(3) Form Overlay registration data request

In receiving this command, the form overlay registration information is responded.

- a) Command SOH (01H)+FO
- b) Responded Status Definition
STX + Form Overlay Registration content + ETX
- c) Status Byte Definition

No.	Item	Contents	Byte number
1	Registration number	01 (ASCII code)	2
2	Registration name	Registration name (ASCII code)	16

(4) Font Configuration Data Request

In receiving this command, the printer font data is responded.

- a) Command SOH (01H) + FG
- b) Responded Status Definition
STX + the following statuses (The response byte number changes depending on the font number) + ETX
- c) Status Byte Definition

No.	Item	Contents	Byte number
1	Font ID number	ASCII code specification	2
2	Logo /Character selection	0: Character 1: Logo	2
3	Font name	ASCII code specification	32
4	Font Style (character decoration)	ASCII code specification	12
5	Font size (points)	ASCII code specification	4
6	Character width	Dot specification (binary code)	2
7	Character height	Dot specification (binary code)	2
8	Font size (1 character byte)	Dot specification (binary code)	4
9	Font registration number	Binary code specification	4
10	Font data leading address	Binary code	4
11	Total size	Binary code	4
12	Vertical writing flag	Vertical / Horizontal writing	2
13	Character pitch	Fixed pitch / variable pitch	1
14	Family	Family attribute	1
15	Character set	Character set	1
16	Italic	Italic attribute	1
17	Weight	Emphatic attribute	2
18	Average character width	Dot specification	2
19	Accent	Dot specification	2
20	Registration start code	1 byte character registration start code	2
21	Registration end code	1 byte character registration end code	2
22	Spare		8
23	Code 1	Binary code	2
24	Horizontal valid size 1	Binary code	2
25	Left gap size 1	Binary code	2
*	*	*	*
*	*	*	*
*	Code ??	Binary code	2
*	Horizontal valid size??	Binary code	2
*	Left gap size??	Binary code	2

6

TROUBLESHOOTING

If you are unable to produce printouts on the GT Series printers, use this section to make sure the basics have been checked, before deciding you are unable to proceed any further. The section is divided into seven parts:

- Initial Checklist
- Checklist for the Centronics Parallel Interface
- Checklist for the RS232C Serial Interface
- Understanding STATUS, RIBBON and LABEL indicators
- Understanding the LCD error messages
- Understanding the LCD warning messages
- General Troubleshooting Guide

6.1 INITIAL CHECKLIST

1. Is the printer powered up and ON LINE?
2. Is the ERROR light on the front panel OFF? If this light is ON, it may mean the print head assembly is open or another error condition is present.
3. Are the Label Hold-Down and Print Head Assembly in the latched position?

6.2 USING THE CENTRONICS (PARALLEL) INTERFACE

1. Is the IBM parallel printer cable connected securely to your parallel port (DB-25S Female) on the PC and to the Centronics connector on the printer?
2. Is there more than one parallel interface port on your PC (LPT1, LPT2, etc.)? If so, make sure you are sending data out the correct port.
3. When you send the print job to the printer, and it does not respond, do you get an error message on your PC that says "Device Fault" or something similar? This may mean that the computer doesn't know the printer is there. Verify that:
 - a. Both ends of the cable are securely inserted into their respective connectors.
 - b. The printer is ONLINE.
 - c. The cable is not defective. There are other things that can cause this error message on your computer, but at this stage, a defective cable may be one of the reasons.

Observations

6.2 USING THE CENTRONICS (PARALLEL) INTERFACE (CONT'D)

Observations

4. When you send the print job to the printer and it does not respond, and there is no error message on the PC:
 - A. Check your data stream for some of the basics. Is your job framed as follows?
`<ESC>A—DATA—<ESC>Z`
 - B. Verify that you've included all required parameters in the data stream.
 - C. Verify the following:
 - You have not typed a "0" (zero) for an "O" (letter) or vice-versa.
 - You have not missed any <ESC> characters where they're needed.
 - Make sure all printer command codes are capital letters.
 - Your protocol codes are set for Standard or Non-Standard and your data stream is consistent with these.
5. If you've checked all of the above and the printer still isn't printing, you may want to try a Receive Buffer Hex Dump to determine what (if anything) the printer is receiving from your computer. To print Hex Dumps see page 3-24, Configuration and Operation.

The Centronics port is now listening for incoming data. Send your print job. The printer will now print (only once) a Hexadecimal (Hex) Dump of everything it received from the host computer. Each 2-digit hexadecimal character represents a character the printer received. It may be tedious, but now you can analyze and troubleshoot the data stream.

6. While checking the Hex Dump printout, look out for the sequence 0D 0A, which is a combination of Carriage Return and Line Feed characters. The command string should be continuous, and you should not see CR or LF characters between the Start Command (**<ESC>A**) and the Stop Command (**<ESC>Z**).

If you are using BASIC, it may be adding these characters automatically as the line wraps. Adding a "width" statement to your program can help to suppress these extra 0D 0A characters by expanding the line length up to 255 characters. See the beginning of the Programming Reference, under Command Codes, for details on writing a program in BASIC.

If you are not programming in BASIC, check to see if you have an equivalent statement in the language you're using, to suppress extra carriage returns and line feeds from your data being sent out to the printer. The data stream should be one complete line going to the printer.

6.3 USING THE RS232C (SERIAL) INTERFACE

1. Is the RS232C Serial cable connected securely to your serial port on the PC (DB- 25S Male) and to the RS232C connector on the printer?
2. Is the cable defective? At the very least, you should be using a "Null Modem Cable," which crosses pins in a specific manner. This should enable your printer to print. But we recommend that you eventually use a cable built to specifications as described in **Section 5: Interface Specifications**
3. Check for obvious errors in the data stream. Remember that all print jobs for serial data must be framed by an **STX** and **ETX**. Again, see the **Section 5: Interface Specifications** if necessary.
4. If after sending your job to the printer, it only "beeps" indicating a "framing error" message, you may have a configuration problem. There may be some inconsistencies with the Baud Rate, Parity, Data Bits, or Stop Bits in relation to your host computer. If you are confused as to what the printer's current RS232 settings are, you may choose the SATO defaults (all DIP switches in the OFF position) to achieve 9600 baud, no parity, 8 data bits, and 1 stop bit.

Observations



6.4 UNDERSTANDING THE STATUS INDICATORS





The LED indicators flash to indicate the current status of the printer. Another indicator is the built-in buzzer which sounds audible beeps to alert the user.

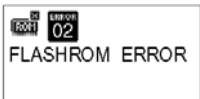

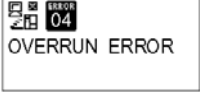
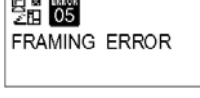
Indicator	Activity	Cause	Remedy	Illustration
STATUS	Flashes (green)	The receive buffer is getting low, due to abundant incoming data.	You can continue using the printer. The flashing should stop as soon as the receive buffer clears more of the incoming data	<p>The illustration shows the printer's control panel. At the top, there are five icon slots labeled 'Icon 1' through 'Icon 5'. Below them is an LCD screen displaying 'ONLINE' and 'QTY:000000'. Under the screen are five indicator lights labeled 'POWER', 'ON LINE', 'STATUS', 'LABEL', and 'RIBBON'. Below these are two large buttons labeled 'LINE' and 'FEED'. At the bottom, there is a control pad with a central four-way directional pad and four buttons labeled 'FUNCTION', 'ENTER', 'CANCEL', and 'VOLUME'. Below the directional pad are four buttons labeled 'PITCH', 'OFFSET', and 'DARKNESS', each with a '+' symbol.</p>
RIBBON	Flashes (red)	The ribbon reel is running low on ribbon.	You can continue using the printer. Replace the ribbon if the Ribbon End error message appears during printing.	
LABEL	Flashes (red)	The label reel is running low on label.	You can continue using the printer. Replace the label reel if the Label End error message appears during printing.	
BUZZER	Beeps	There is an error in an incoming printer command or print area specification setting.	Correct the printer command or print area settings.	

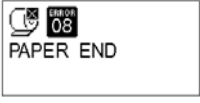

For information on error messages and icons, proceed to the next section.

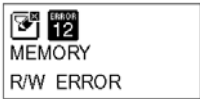
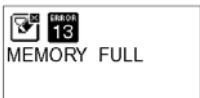

6.5 UNDERSTANDING THE LCD ERROR MESSAGES

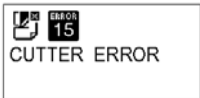
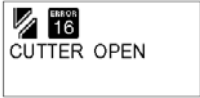
Error No.	LCD Message	Description
01		Machine Error
		Cause: Circuit board problem Remedy: Contact a sales outlet, dealer, or service center Alarm sound: One long beep External signal: Machine error
02		Flash ROM Error
		Cause(s): 1. Flash ROM cannot be accessed 2. Illegal firmware operation requested by software Remedy: Contact a sales outlet, dealer, or service center Alarm sound: One long beep External signal: Machine error
03		Parity Error
		Cause(s): 1. RS-232C communication settings fail parity checking 2. Error in cable connection Remedy: Check and correct communication cables and settings Alarm sound: Three short beeps External signal: Machine error
04		Overrun Error
		Cause(s): 1. RS-232C communication settings exceed legal values 2. Error in cable connection Remedy: Check and correct communication cables and settings Alarm sound: Three short beeps External signal: Machine error
05		Framing Error
		Cause(s): 1. RS-232C communication settings are not in the correct frame size 2. Cable connection trouble. Remedy: Check and correct communication cables and settings Alarm sound: Three short beeps External signal: Machine error
06		Buffer Overflow error
		Cause(s): 1. Size of received data exceeds size of receiving buffer 2. Mismatch in sending/receiving communication protocols Remedy: Modify the system to establish the correct communication protocol Alarm sound: Three short beeps External signal: Machine error

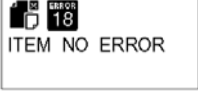

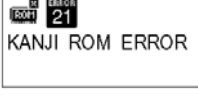
Error No.	LCD Message	Description
07		<p>Head Open error</p> <p>Cause(s):</p> <ol style="list-style-type: none"> 1. The head unit is not properly locked in place 2. The micro switch that detects the head lock status is malfunctioning <p>Remedy: Lock the head unit properly. If the same error message persists, contact a sales outlet, dealer, or contact the service center</p> <p>Alarm sound: Three short beeps</p> <p>External signal: Machine error</p>
08		<p>Paper End error</p> <p>Cause(s):</p> <ol style="list-style-type: none"> 1. The media supply has run out 2. The media is not set correctly <p>Remedy: Set the media correctly</p> <p>Alarm sound: Three short beeps</p> <p>External signal: Paper end</p>
09		<p>Ribbon End error</p> <p>Cause(s):</p> <ol style="list-style-type: none"> 1. The ribbon supply has run out 2. The ribbon has been damaged <p>Remedy:</p> <ol style="list-style-type: none"> 1. Set the ribbon correctly 2. Clean the ribbon path <p>Alarm sound: Three short beeps</p> <p>External signal: Ribbon end</p>
10		<p>Sensor error</p> <p>Cause(s):</p> <ol style="list-style-type: none"> 1. The sensitivity level of paper sensor is incorrect 2. The sensor type selection is incorrect for the media used <p>Remedy:</p> <ol style="list-style-type: none"> 3. The paper flow is erratic 1. Re-adjust the sensitivity level of paper sensor 2. Choose the correct sensor type to match the media being used 3. Clean the paper path to establish a smooth paper flow. If the same error message is still displayed, contact a sales outlet, dealer, or service center <p>Alarm sound: Three short beeps</p> <p>External signal: Machine error</p>
11		<p>Head related error</p> <p>Cause: There is a problem with the print head</p> <p>Remedy: Replace the head. Clean the head and recheck. If the same error message is still displayed, contact a sales outlet, dealer, or service center</p> <p>Alarm sound: One long beep</p> <p>External signal: Machine error</p>

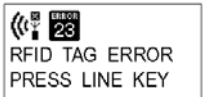
Error No.	LCD Message	Description
12		<p>Memory Writing error</p> <p>Cause(s):</p> <ol style="list-style-type: none"> 1. The memory cartridge is not inserted 2. There is no space left for copying 3. The writing or reading operation has failed for some reason 4. The memory has not been properly formatted <p>Remedy:</p> <ol style="list-style-type: none"> 1. Make sure a memory cartridge has been installed 2. Check that there is enough space for the memory operation 3. Replace the memory cartridge 4. Format or reformat the memory cartridge <p>Alarm sound: One long beep</p> <p>External signal: Machine error</p>
13		<p>Memory Reading error</p> <p>Cause: There is no available space in the cartridge</p> <p>Remedy: Delete unnecessary data in the cartridge to free up memory space</p> <p>Alarm sound: One long beep</p> <p>External signal: Machine error</p>
14		<p>Download Data Error</p> <p>Cause(s):</p> <ol style="list-style-type: none"> 1. Received invalid download 2. There is no download area <p>Remedy:</p> <ol style="list-style-type: none"> 1. Check the download data 2. Check the download data size <p>Alarm sound: One long beep</p> <p>External signal: Machine error</p>
15		<p>Cutter error</p> <p>Cause(s):</p> <ol style="list-style-type: none"> 1. The cutter unit is jammed or clogged <p>Remedy:</p> <ol style="list-style-type: none"> 2. The cutter blade has not returned to the specified position 1. Clean the cutter unit and clear any paper jams 2. Press the FEED button to reinstate the proper cutter blade position. If the same error message persists, contact a sales outlet, dealer, or service center <p>Alarm sound: Three short beeps</p> <p>External signal: Machine error</p>
16		<p>Cutter Open error</p> <p>Cause(s):</p> <ol style="list-style-type: none"> 1. The upper bracket of the cutter unit is open 2. The sensor is malfunctioning <p>Remedy: Close the upper bracket of the cutter unit. If the same error message persists, contact a sales outlet, dealer, or service center</p> <p>Alarm sound: Three short beeps</p> <p>External signal: Machine error</p>

Error No.	LCD Message	Description
17		BCC Check error
		<p>Cause: BCC attached to sending data (for an item) is different</p> <p>Remedy: Check the settings controlling data communication</p> <p>Alarm sound: Three short beeps</p> <p>External signal: Machine error</p>
18		Item Number error
		<p>Cause: The sequence number of print data (for an item) does not match the sequence number of the previously printed data</p> <p>Remedy: Check the settings controlling data communication</p> <p>Alarm sound: Three short beeps</p> <p>External signal: Machine error</p>
19		Winding Full error
		<p>Cause(s): 1. The label rewinder needs to be emptied 2. The sensor is malfunctioning</p> <p>Remedy: Remove the wound label. If the same error message persists, contact a sales outlet, dealer, or service center</p> <p>Alarm sound: Three short beeps</p> <p>External signal: Machine error</p>
20		Head Density error
		<p>Cause(s): 1. The print head has not been mounted properly in the printer 2. An unsupported print head has been mounted</p> <p>Remedy: Check that the print head is suitable for use with this printer, and that the print head is mounted properly</p> <p>Alarm sound: Three short beeps</p> <p>External signal: No output</p>
21		Kanji ROM error
		<p>Cause: Invalid Kanji data has been read from the Kanji ROM</p> <p>Remedy: Make sure the Kanji ROM has been properly mounted. If the same error message persists, contact a sales outlet, dealer, or service center</p> <p>Alarm sound: Three short beeps</p> <p>External signal: Machine error</p>

Error No.	LCD Message	Description
23		RFID Tag error Cause: Writing into RFID tag could not be performed normally Remedy: Write information in another RFID tag Alarm sound: Three short beeps External signal: Machine error
		RFID Tag error Cause: Writing into the RFID tag could not be performed normally Remedy: Replace the RFID tag. Press the Line key to retry Alarm sound: Three short beeps External signal: Machine error
		RFID Protect error Cause: The RFID tag is write-protected. Information cannot be written to it Remedy: Replace the tag with one that is not write-protected Alarm sound: Three short beeps External signal: Machine error
24		Non-lock error Cause: The knob of the ribbon-winding unit is not locked Remedy: Lock the knob of the ribbon-winding unit Alarm sound: Three short beeps External signal: Machine error

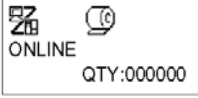
6.6 LCD WARNING MESSAGES

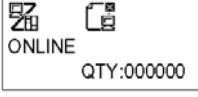
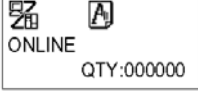
Error No.	LCD Message	Description	
01		Warning: Label Near End	
		Cause: Remedy: Alarm sound: External signal:	The label supply roll is almost running out Be ready to replenish the label roll One long beep No output
02		Warning: Ribbon Near End	
		Cause: Remedy: Alarm sound: External signal:	The amount of ribbon remaining in the printer is low Be ready to replenish the ribbon One long beep Ribbon near end
03		Warning: Receive Buffer Near Full	
		Cause: Remedy: Alarm sound: External signal:	The free space in the buffer memory is running low Regulate the sending of data to the printer until received data has been processed. Three short beeps No output
04		Warning: Command Error	
		Cause: Remedy: Alarm sound: External signal:	A command error has been detected Review the print data Three short beeps No output
05		Warning: Head Check Error	
		Cause: Remedy: Alarm sound: External signal:	The normal head check function detected an error in the print head, but by setting the head check function to Barcode instead of Normal check mode, printing was able to resume, as the error does not affect the quality of barcodes being printing Although the print head can still be used for now, immediate attention should be given to correct the head error or replace the print head before the situation worsens Three short beeps No output

6.7 TROUBLESHOOTING GUIDE

Symptom: The display remains blank when the power switch is pressed

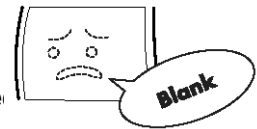

No.	What to check	Remedy
1	Has the power cable been inserted into the power outlet securely?	Insert the power cable securely into the outlet.
2	Is the power cable damaged?	Inspect the power cable for signs of damage. If possible, try using another printer power cable. Purchase a new power cable specifically designed for this printer, from the sales outlet or dealer where you bought the printer from. Never use any other power cable but the power cable specifically designed for this printer.
3	Is electricity coming to the power outlet feeding the printer?	Connect another electrical appliance to the power outlet to check for power. If there is a problem with the main power, check if electricity is coming to the building. Also check if power failure has occurred.
4	Has the power fuse of the building blown, or has the circuit breaker been tripped?	Replace the power fuse and reset the circuit breaker.

Caution

Do not operate the power switch or handle the power cable with a wet hand. You may suffer electric shocks as a result.

Symptom: Paper is fed but not printed

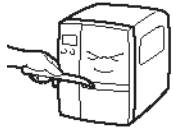

No.	What to check	Remedy
1	Is the printer head dirty, or is there any label stuck to the printer head?	If the printer head is dirty, wipe off the dirt with the supplied cleaning set. If a label is stuck to the printer head, take it away. * Do not use metallic object to remove it (the printer head may be damaged). If glue of the label is stuck to the printer head, wipe it off with the supplied cleaning set. 
2	Are you using genuine SATO paper and carbon ribbons for the printer?	Be sure to use genuine paper and carbon ribbon specifically designed for the printer.
3	Is the paper sensor dirty?	If the paper sensor is dirty, wipe off the dirt with the supplied cleaning set. See Section 4: Cleaning and Maintenance.
4	Is the carbon ribbon wound correctly?	If the knob of the ribbon-winding unit is not set to its original position, remove the carbon ribbon already wound, and return the knob to its original position.
5	Is the data/signal sent from the computer correct?	Turn on the power switch again. If the message still appears, check the software on the computer or the configuration for connections.

Caution

Pull out the power cable before cleaning the printer.

6.7 TROUBLESHOOTING GUIDE (CONT'D)

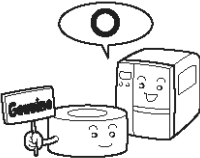
Symptom: Low quality print

No.	What to check	Remedy
1	Are the paper and carbon ribbon set correctly?	Check if the paper and carbon ribbon are securely fixed. Also, lower the head-open lever of the printer head unit, and check if the paper and carbon ribbon are in the normal position.
2	Are the paper and carbon ribbon set correctly?	Check the paper and carbon ribbon. Set the print density again.
3	Is the platen roller dirty?	If the platen roller is dirty, wipe off the dirt with the supplied cleaning set.
4	Is the printer head dirty, or is a label on the head?	<p>If the print head is dirty, wipe off the dirt with the attached cleaning set. If a label is on the head, take it away.</p> <p>* Do not use a metallic object to remove it (the printer head may be damaged). If glue of the label is stuck to the printer head, wipe it off with the supplied cleaning set.</p> <p>See Section 4: Cleaning and Maintenance.</p> 
5	Are you using stained paper?	Use clean paper.
6	<p>Are you using genuine paper and carbon ribbon specifically designed for the printer?</p> 	<p>Be sure to use genuine paper and carbon ribbon specifically designed for the printer.</p> 

Caution

Pull out the power cable before cleaning the printer.

6.7 TROUBLESHOOTING GUIDE (CONT'D)

Symptom: Print position is misaligned

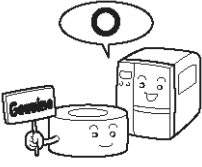
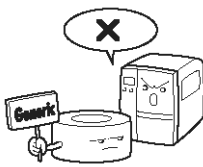
No.	What to check	Remedy
1	Are the paper and carbon ribbon set correctly?	Fix the paper and carbon ribbon securely. Also, release the head-open lever of the printer head unit, then set the paper and carbon ribbon to the normal position again . Finally, latch the print head back in place.
2	Is the platen roller dirty?	If the platen roller is dirty, wipe off the dirt with the supplied cleaning set .
3	Is the paper/carbon ribbon you are using deformed?	If the edges of the paper/carbon ribbon are deformed, the paper cannot be fed normally. Use new paper/ carbon ribbon which are not deformed.
4	Are you using genuine SATO paper and carbon ribbons specifically designed for the printer? 	Be sure to use genuine paper and carbon ribbon specifically designed for the printer. Generic supplies may cost less, but can result in poor printing quality or shortened equipment life, leading to higher operating costs in the long run. 
5	Is the paper sensor dirty?	If the paper sensor is dirty, wipe off the dirt with the supplied cleaning set. See Section 4: Cleaning and Maintenance .
6	Is the data/signal sent from the computer correct?	Turn on the power switch again. If the error message still appears, check the software on the computer or the configuration of the connections.
7	Are the pitch correction (variable potentiometer) or base point correction (User Mode setting) correct?	Set the pitch correction (variable potentiometer) or base point correction (User Mode setting) again.

Caution

Pull out the power cable before cleaning the printer.

This page is intentionally left blank

7

OPTIONAL ACCESSORIES

7.1 INTRODUCTION

This section contains details of the optional accessories available for the GT printer series:

- Interface boards
- Peelers
- Cutters
- Winders
- RFID unit
- Additional memory

7.2 AVAILABLE INTERFACE BOARDS

Interface boards enable the printer to exchange data with computers, computer networks and related input/output devices. By installing different interface boards, you can adapt GT printers to fit in a wide range of related equipment and usage scenarios.

The following interface boards are available for the GT series:

- ▣ Parallel interface board (IEEE1284) (optional or bundled)
- ▣ Serial interface board (RS-232C) (optional)
- ▣ USB interface board (optional)
- ▣ 10BaseT/100Base-TX LAN interface board (optional)
- ▣ Wireless LAN IEEE802.11b interface board (optional)
- ▣ 10BaseT/100Base-TX mini LAN board (optional)
- ▣ EXT connector (external signal interface) (optional)

For more advanced details on interfaces, see **Section 5: Interface Specifications**.

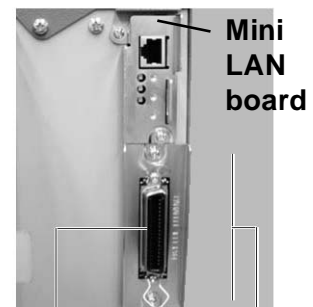

Interface connector

Caution

Before installing or removing interface boards, be sure to turn off the printer first. Discharge static electricity from your body before touching any of the electronic parts. Failure to observe these precautions can result in severe damage to the components.

7.3 LABEL MANAGEMENT ACCESSORIES

- ❑ **Peel unit with mounting winder (factory option)**
Mounts on the printer to automatically peel labels from their liner (mounting sheet) backing sheet. The winder is supplied to roll up the backing sheet neatly for easy disposal by the operator at a later time.
- ❑ **Simplified peel unit (factory option)**
Mounts on the printer to automatically peel labels from their liner (mounting sheet) backing sheet. No winder is supplied to roll the backing sheet neatly.
- ❑ **Cutter Unit (factory option)**
Mounts on the printer to automatically cut labels as they are printed.
- ❑ **Cutter Unit for Linerless labels (factory option)**
Mounts on the printer to automatically cut linerless labels—that is, labels that are supplied without mounting sheets.
- ❑ **Internal winding unit (factory option)**
A winder that mounts inside the printer chassis, to roll up labels as they are printed.
- ❑ **External winding unit (factory option)**
A winder that mounts outside the printer chassis, to roll up labels as they are printed.
- ❑ **Detection scanner unit (factory option)**
- ❑ **RFID unit (factory option)**
Enables the printer to read and write to a specified range of RFID tags and labels.

Instructions for installing each of the above accessories are supplied with the respective products. An authorized SATO reseller can also arrange to install the products on site.

For more information on any of the accessories available for the GT series printers, please contact an authorized SATO dealer near you.

7.3 PCMCIA MEMORY CARTRIDGE

The GT series features a memory cartridge slot for the addition of optional memory cartridges that are purchased from SATO.

The memory cartridge slot is located behind a protective cover found within the printer's media storage area. Memory cartridges of up to 24 MB can be installed for the storage of user data and graphics.

7.3.1 Installing the memory card

1. Lift up the front cover.
2. Tilt the knob of the memory cartridge cover inside and remove the memory cartridge cover.
3. Insert the memory cartridge.
4. Press the knob of the memory cartridge cover and press it firmly into place.
5. Close the front cover. The additional memory is now ready for use.
6. To remove the memory cartridge, reverse the procedure described here.

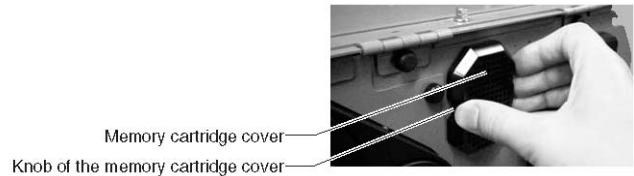

Caution

- If a memory access command is sent to the printer that does not have a memory cartridge present, an error will occur. In that case, make sure to install a memory cartridge before issuing any commands to access a memory cartridge.
- Before installing or removing a memory card, be sure to turn off the printer first.
- To prevent foreign objects and dust from entering the memory card slot, always make sure the memory card cover is firmly pressed into place, regardless of whether a memory card is installed or not.

This page is intentionally left blank

Free Manuals Download Website

<http://myh66.com>

<http://usermanuals.us>

<http://www.somanuals.com>

<http://www.4manuals.cc>

<http://www.manual-lib.com>

<http://www.404manual.com>

<http://www.luxmanual.com>

<http://aubethermostatmanual.com>

Golf course search by state

<http://golfingnear.com>

Email search by domain

<http://emailbydomain.com>

Auto manuals search

<http://auto.somanuals.com>

TV manuals search

<http://tv.somanuals.com>