

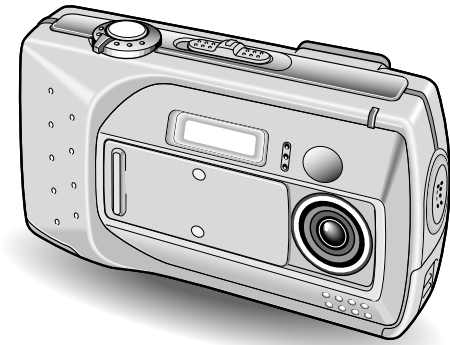

# SERVICE MANUAL

## Color Digital Camera



## VPC-SX560EX

(Product Code : 126 279 01)  
(Europe)  
(PAL General)

## VPC-SX560E

(Product Code : 126 279 03)  
(U.K.)

## VPC-SX560

(Product Code : 126 279 02)  
(U.S.A.)  
(Canada)

### Contents

1. OUTLINE OF CIRCUIT DESCRIPTION .....	2
2. DISASSEMBLY .....	13
3. ELECTRICAL ADJUSTMENT .....	16
4. USB STORAGE INFORMATION	
REGISTRATION .....	21
5. TROUBLESHOOTING GUIDE .....	22
6. PARTS LIST .....	23
CABINET AND CHASSIS PARTS 1 .....	23
CABINET AND CHASSIS PARTS 2 .....	24
ELECTRICAL PARTS .....	25
ACCESSORIES .....	32
PACKING MATERIALS .....	32
CIRCUIT DIAGRAM (Refer to the separate volume)	

### PRODUCT SAFETY NOTICE

The components designated by a symbol (  $\triangle$  ) in this schematic diagram designates components whose value are of special significance to product safety. Should any component designated by a symbol need to be replaced, use only the part designated in the Parts List. Do not deviate from the resistance, wattage, and voltage ratings shown.

CAUTION : Danger of explosion if battery is incorrectly replaced.

Replace only with the same or equivalent type recommended by the manufacturer.  
Discard used batteries according to the manufacturer's instructions.

NOTE : 1. Parts order must contain model number, part number, and description.  
2. Substitute parts may be supplied as the service parts.  
3. N. S. P. : Not available as service parts.

Design and specification are subject to change without notice.

# 1. OUTLINE OF CIRCUIT DESCRIPTION

## 1-1. CA1 CIRCUIT DESCRIPTION

### Around CCD block

#### 1. IC Configuration

IC903 (ICX267)	CCD imager
IC902, IC904, IC908 (74ACT04MTC)	H driver
IC907 (CXD3400N)	V driver
IC905 (AD9840)	CDS, AGC, A/D converter

#### 2. IC903 (CCD)

##### [Structure]

Interline type CCD image sensor

Optical size	Diagonal 8 mm (1/2 type)
Effective pixels	1392 (H) × 1040 (V)
Pixels in total	1434 (H) × 1050 (V)
Actual pixels	1360 (H) × 1024 (V)

Optical black

Horizontal (H) direction: Front 2 pixels, Rear 40 pixels

Vertical (V) direction: Front 8 pixels, Rear 2 pixels

Dummy bit number Horizontal : 20 Vertical : 3

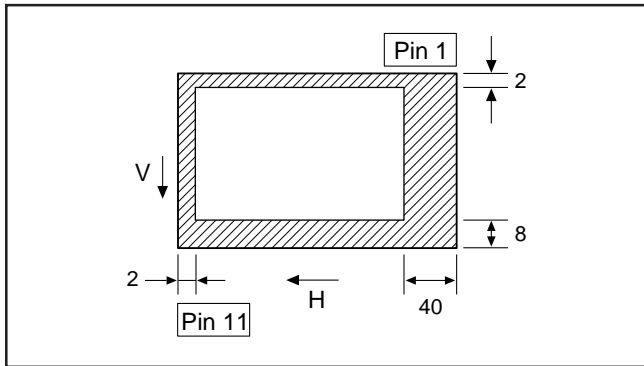

Fig. 1-1. Optical Black Location (Top View)

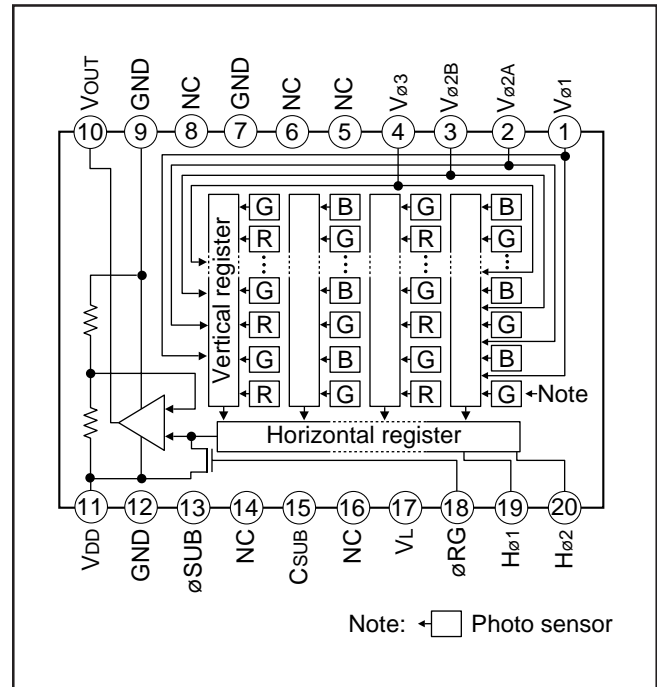

Fig. 1-2. CCD Block Diagram

Pin No.	Symbol	Pin Description	Waveform	Voltage
1	V <sub>1</sub>	Vertical register transfer clock		-8.0 V, 0 V
2, 3	V <sub>2A</sub> , V <sub>2B</sub>	Vertical register transfer clock		-8.0 V, 0 V, 15 V
4	V <sub>3</sub>	Vertical register transfer clock		-8.0 V, 0 V
5, 6, 8, 14, 16	NC			
7, 9, 12	GND	GND	GND	0 V
10	V <sub>OUT</sub>	Signal output		Aprox. 7 V
11	V <sub>DD</sub>	Circuit power	DC	15 V
13	SUB	Substrate clock	DC	Different from every CCD
15	C <sub>SUB</sub>	Substrate bias		Different from every CCD
17	V <sub>L</sub>	Protection transistor bias	DC	-8 V
18	RG	Reset gate clock		12 V, 17 V
19	H <sub>1</sub>	Horizontal register transfer clock		0 V, 5 V
20	H <sub>2</sub>	Horizontal register transfer clock		0 V, 5 V

Table 1-1. CCD Pin Description

---- When sensor read-out

### 3. IC902, IC904, IC908 (H Driver) and IC907 (V Driver)

An H driver and V driver are necessary in order to generate the clocks (vertical transfer clock, horizontal transfer clock and electronic shutter clock) which driver the CCD.

IC902, IC904 and IC908 are inverter IC which drives the horizontal CCDs (H1 and H2). In addition the XV1-XV3 signals which are output from IC102 are the vertical transfer clocks, and the XSG1 and XSG signal which is output from IC102 is superimposed onto XV2A and XV2B at IC907 in order to generate a ternary pulse. In addition, the XSUB signal which is output from IC102 is used as the sweep pulse for the electronic shutter, and the RG signal which is output from IC102 is the reset gate clock.

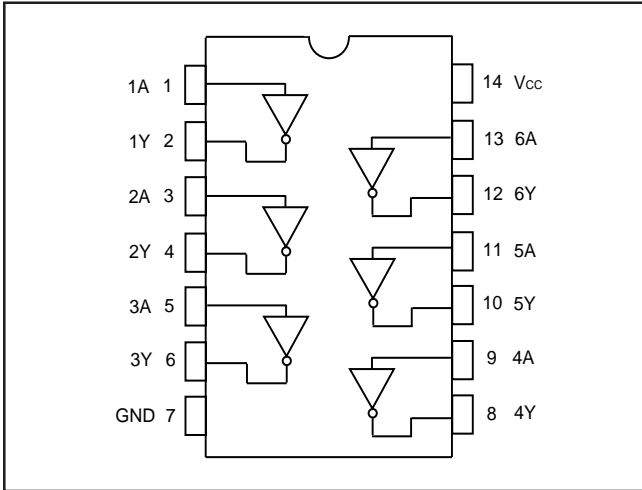

Fig. 1-3. IC902, IC904 and IC908 Block Diagram

### 4. IC905 (CDS, AGC Circuit and A/D Converter)

The video signal which is output from the CCD is input to Pin (30) of IC905. There are S/H blocks inside IC905 generated from the XSHP and XSHD pulses, and it is here that CDS (correlated double sampling) is carried out.

After passing through the CDS circuit, the signal passes through the AGC amplifier. It is A/C converted internally into a 10-bit signal, and is then input to IC102 of the CA2 circuit board. The gain of the AGC amplifier is controlled by serial data which is output from IC102 of the CA2 circuit board.

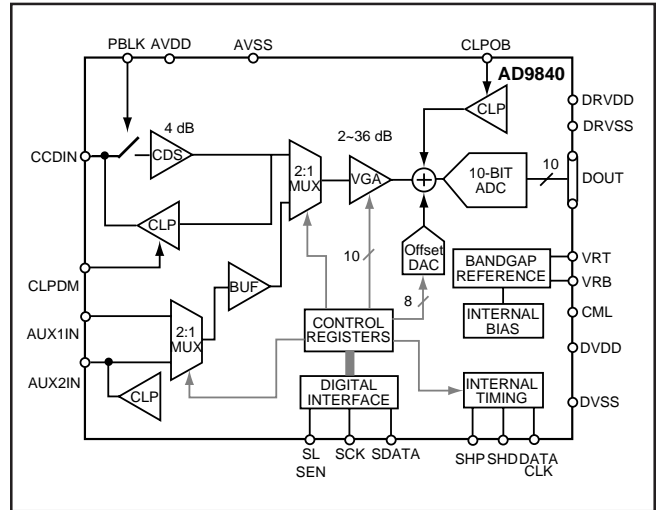

Fig. 1-5. IC905 Block Diagram

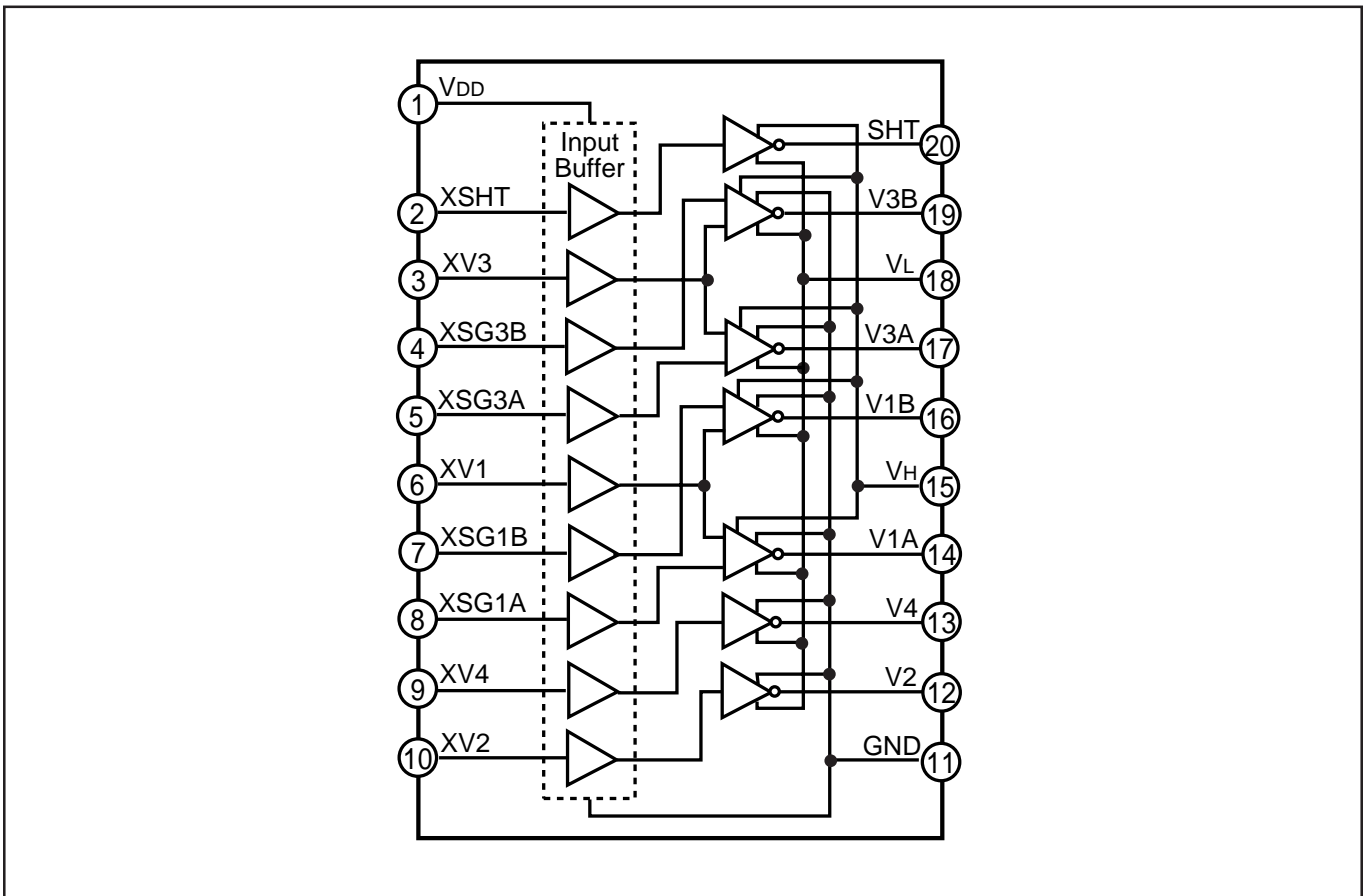

Fig. 1-4. IC907 Block Diagram

## 5. Transfer of Electric Charge by the Horizontal CCD

The transfer system for the horizontal CCD employs a 2-phase drive method.

The electric charges sent to the final stage of the horizontal CCD are transferred to the floating diffusion, as shown in Fig. 1-6. RG is turned on by the timing in (1), and the floating diffusion is charged to the potential of PD. The RG is turned off by the timing in (2). In this condition, the floating diffusion is floated at high impedance. The H1 potential becomes shallow by the timing in (3), and the electric charge now moves to the floating diffusion.

Here, the electric charges are converted into voltages at the rate of  $V = Q/C$  by the equivalent capacitance  $C$  of the floating diffusion. RG is then turned on again by the timing in (1) when the H1 potential becomes deep.

Thus, the potential of the floating diffusion changes in proportion to the quantity of transferred electric charge, and becomes CCD output after being received by the source follower. The equivalent circuit for the output circuit is shown in Fig. 1-7.

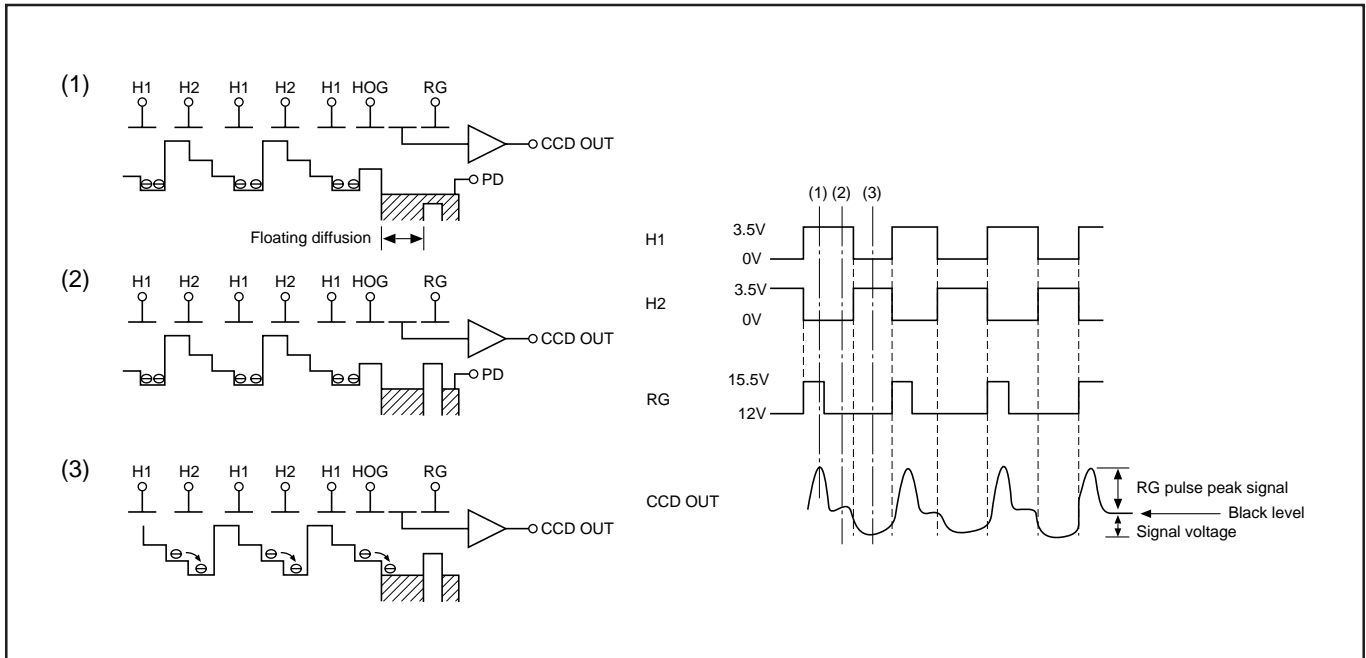

Fig. 1-6. Horizontal Transfer of CCD Imager and Extraction of Signal Voltage

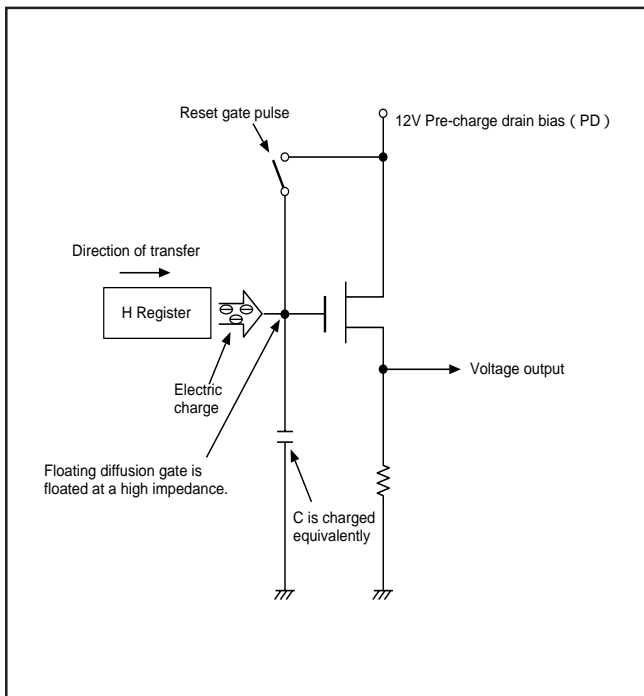

Fig. 1-7. Theory of Signal Extraction Operation

## 6. Lens drive block

### 6-1. Shutter drive

The two control signals (SIN1, SIN2) which are output from the ASIC expansion port (IC106) are converted into drive pulses (SOUT1, SOUT2) by the motor drive (IC951), and the shutter is opened and closed by regular current drive.

### 6-2. Iris drive

The two control signals (IIN1, IIN2) which are output from the ASIC expansion port (IC106) are converted into drive pulses (IOUT1, IOUT2) by the motor drive (IC952), and the iris is opened and closed.

### 6-3. Focus drive

The focusing motor drive clock (FCLK) which are output from the ASIC makes drive signal (FA1, FA2, FB1 and FB2) from drive direction signal (FCW) by driver (IC951) and is then used to drive the micro stepping motor for focusing motor. Detection of the standard focusing positions is carried out by means of the photointerruptor (FOCUS PI) inside the lens block.

## 1-2. CA2 CIRCUIT DESCRIPTION

### 1. Circuit Description

#### 1-1. Scanning converter (Interlace converter)

This circuit uses the function of a 64-Mbit SDRAMs to convert the non-interlaced signal which is output from the CCD into an interlaced signal for the video monitor.

#### 1-2. Camera signal processor

This comprises circuits such as the digital clamp circuit, white balance circuit, circuit, color signal generation circuit, matrix circuit and horizontal aperture circuit.

##### 1. Digital clamp circuit

The optical black section of the CCD extracts 16-pixel averaged values from the subsequent data to make the black level of the CCD output data uniform for each line. The 16-pixel averaged value for each line is taken as the sum of the value for the previous line multiplied by the coefficient  $k$  and the value for the current line multiplied by the coefficient  $1-k$ .

##### 2. White balance circuit

This circuit controls the white balance by using the AWB judgement value computed by the CPU to control the gain for each R, G and B pixel based on the CCD data which has been read.

##### 3. circuit

This circuit performs (gamma) correction in order to maintain a linear relationship between the light input to the camera and the light output from the picture screen.

##### 4. Color generation circuit

This circuit converts the CCD data into RGB signals.

##### 5. Matrix circuit

This circuit generates the Y signals, R-Y signals and B-Y signals from the RGB signals.

##### 6. Horizontal aperture circuit

This circuit is used generate the aperture signal.

#### 1-3. SDRAM controller

This circuit outputs address, RAS, CAS and AS data for controlling the SDRAM. It also refreshes the SDRAM.

#### 1-4. PIO

The expansion parallel port can be used for functions such as stroboscope control and LCD driver control.

#### 1-5. SIO (Serial control)

This is the interface for the 4-bit microprocessor.

#### 1-6. USB control

This is communicated PC with 12 Mbps.

#### 1-7. TG, SG block

This is the timing generation circuit which generates the clocks (vertical transfer clock and electronic shutter clock) which drive the CCD.

#### 1-8. 8-bit D/A circuit (Audio)

This circuit converts the audio signals (analog signals) from the microphone to 8-bit digital signals.

#### 1-9. 8-bit A/D circuit (Audio)

The audio signals which were converted to digital form by the 8-bit A/D circuit are temporarily to a sound buffer and then recorded in the SSFDC card. During playback, the 8-bit D/A circuit converts these signals into analog audio signals.

#### 1-10. Sound buffer

Audio memory

#### 1-11. LCD driver

The Y/C signals which are input to the LCD driver are converted to RGB signals, and the timing signal which is necessary for LCD monitor display and the RGB signals are then supplied to the LCD monitor.

#### 1-12. LCD monitor

This is the image display device which displays the image signals supplied from the LCD driver.

#### 1-13. UART

This circuit is used for transmitting serial data to a PC. The interface is RS-232C-compatible.

#### 1-14. Memory card control

This reads data from the memory card and stores it in SDRAM, and writes out the image data stored in SDRAM. In addition, error correction is carried out when the data is read.

#### 1-15. MJPEG compression

Still and continuous frame data is converted to JPEG format, and movie images are compressed and expanded in MJPEG format.

## 2. Outline of Operation

When the shutter opens, the reset signals, TEST0, TEST1 and the serial signals ("take a picture" commands) from the 8-bit microprocessor are input and record operation starts. When the TG drives the CCD, picture data passes through the A/D and is then input to the ASIC as 10-bit data. This data then passes through the DCLP, AWB, shutter and circuit, after which it is input to the SDRAM. The AWB, shutter, , and AGC value are computed from this data, and two exposures are made to obtain the optimum picture. The data which has already been stored in the SDRAM is read by the CPU and color generation is carried out. Each pixel is interpolated from the surrounding data as being either R, G or B primary color data to produce R, G and B data. At this time, correction of the lens distortion which is a characteristic of wide-angle lenses is carried out. Aperture correction is carried out, and in case of still picture the data is then compressed by the JPEG method and in case of picture it is compressed by MJPEG method and is written to compact flash card. When the data is to be output to an external device, it is read JPEG picture data from the compact flash card and output to PC via the UART.

### 3. LCD Block

During EE, gamma conversion is carried out for the 10-bit RGB data which is input from the A/D conversion block of the CCD to the ASIC in order that the revised can be displayed on the video. The YUV of 640 x 480 is then transferred to the SVRAM.

The data which has accumulated in the SDRAM is after D/A conversion is carried out by SDRAM control circuit inside the ASIC, makes Y/C signal, the data is sent to the LCD panel and displayed.

If the shutter button is pressed in this condition, the 10-bit data which is output from the A/D conversion block of the CCD is sent to the SDRAM (DMA transfer), and is displayed on the LCD as a freeze-frame image.

During playback, the JPEG image data which has accumulated in the compact flash card is converted to RGB signals. In the same way as for EE, the data is then sent to the SDRAM, after which D/A conversion is carried out inside the ASIC, and then the data is sent to the LCD panel and displayed.

The LCD driver is converted Y/C signals to RGB signals from ASIC, and these RGB signals and the control signal which is output by the LCD driver are used to drive the LCD panel. The RGB signals are 1H transposed so that no DC component is present in the LCD element, and the two horizontal shift register clocks drive the horizontal shift registers inside the LCD panel so that the 1H transposed RGB signals are applied to the LCD panel.

Because the LCD closes more as the difference in potential between the VCOM (common polar voltage: fixed at DC) and the R, G and B signals becomes greater, the display becomes darker; if the difference in potential is smaller, the element opens and the LCD become brighter. In addition, the brightness and contrast settings for the LCD can be varied by means of the serial data from the ASIC.

## 1-3. CA3 CIRCUIT DESCRIPTION

### 1. Outline

This is the main CA3 power block, and is comprised of the following blocks.

Switching controller (IC521)

Analog system 5.0 V power output (L5201, Q5203, D5201, C5206)

Backlight power output (L5101, Q5102, D5101, C5106)

### 2. Switching Controller (IC521)

This is the basic circuit which is necessary for controlling the power supply for a PWM-type switching regulator, and is provided with one built-in channel. Feedback from 5 V (A) power supply output is received, and the PWM duty is varied so that each one is maintained at the correct voltage setting level.

#### 2-1. Short-circuit protection circuit

If output is short-circuited for the length of time determined by the condenser which is connected to Pin (2) of IC521, all output is turned off. The control signal (P ON, P(A) ON and LCD ON) are recontrolled to restore output.

### 3. Switching Controller (IC511)

This is the basic circuit which is necessary for controlling the power supply for a PWM-type switching regulator, and is provided with one built-in channel. Feedback from 10 mA (L) power supply output is received, and the PWM duty is varied so that each one is maintained at the correct current setting level.

#### 3-1. Protection circuit

If output is short-circuited for the length of time determined by the condenser which is connected to Pin (2) of IC511 the output is shorted out or the backlighting is open (there is no connection between CN512 and the backlight unit), output will turn off. all output is turned off. The control signal (P ON, P(A) ON and LCD ON) are recontrolled to restore output.

### 4. Analog system 5.0 V Power Output

5 V (A) is output. Feedback is provided to the switching controller (Pin (1) of IC521) so that PWM control can be carried out.

### 5. Backlight Power Output

10 mA (L) is output. The backlighting turns on when current flows in the direction from pin (1) to pin (2) of CN512. At this time, a feedback signal is sent from pin (2) of CN512 to pin (1) of IC511 so that PWM control is carried out to keep the current at a constant level (10 mA).

## 1-4. PW1 POWER CIRCUIT DESCRIPTION

### 1. Outline

This is the main PW1 power circuit, and is comprised of the following blocks.

Switching controller (IC501)

Digital and LCD system and 5.0 V system power output (L5010, Q5002, D5013, C5061, C5015)

Digital 3.3 V system power supply (L5017, Q5009, D5007, C5062)

Digital 3.4 V system power supply (L5001, Q5006, D5004, C5060)

Analog and LCD system power supply (Q5007, T5001)

Series regulator (IC502)

Digital 2.5 V system power supply (Q5008, C5076, C5077)

### 2. Switching Controller (IC501)

This is the basic circuit which is necessary for controlling the power supply for a PWM-type switching regulator, and is provided with four built-in channels, only CH1 (digital 3.3 V), CH3 (5 V system), CH2 (digital 3.4 V) and CH4 (analog and LCD system) are used. Feedback from 3.3 V (D) (CH1), 3.4 V (D) (CH2), 5.0 V (D) (CH3) and +15.0 V (A) or +12.4 V (L) (CH4) power supply outputs are received, and the PWM duty is varied so that each one is maintained at the correct voltage setting level.

#### 2-1. Short-circuit protection circuit

If output is short-circuited for the length of time determined by the condenser which is connected to Pin (17) of IC501, all output is turned off. The control signal (P ON, P(A) ON and LCD ON) are recontrolled to restore output.

### 3. Digital 3.3 V Power Output

3.3 V (D) is output. Feedback for the 3.3 V (D) is provided to the switching controller (Pins (1) of IC501) so that PWM control can be carried out.

### 4. Digital 3.4 V System Power Output

3.4 V (D) is output. Feedback is provided to the switching controller (Pin (12) of IC501) so that PWM control can be carried out.

### 5. 5 V System Power Output

5 V (D) and 5 V (L) are output. Feedback for the 5 V (D) is provided to the switching controller (Pin (25) of IC501) so that PWM control can be carried out.

### 6. Analog and LCD System Power Output

15.0 V (A), -8.0 V (A), 12.4 V (L) and 15 V (L) are output. Feedback for the 15.0 V (A) with view mode and 12.4 V (L) with play mode is provided to the switching controller (Pin (36) of IC501) so that PWM control can be carried out.

### 7. Series Regulator (IC502)

This is provided with one built-in channel. Digital 3.4 V is input, and digital 2.5 V is output.

### 8. Digital 2.5 V System Power Output

2.5 V (D) is output. Feedback for the 2.5 V (D) is provided to the Pin (7) of IC502. The current of Q5008 base is controlled so that the voltage of Q5008 collector is 2.5 V.



## 1-5. PW1 STROBE CIRCUIT DESCRIPTION

### 1. Charging Circuit

When UNREG power is supplied to the charge circuit and the CHG signal becomes High (3.3 V), the charging circuit starts operating and the main electrolytic capacitor is charged with high-voltage direct current.

However, when the CHG signal is Low (0 V), the charging circuit does not operate.

#### 1-1. Power switch

When the CHG signal switches to Hi, Q5406 turns ON and the charging circuit starts operating.

#### 1-2. Power supply filter

L5401 and C5401 constitute the power supply filter. They smooth out ripples in the current which accompany the switching of the oscillation transformer.

#### 1-3. Oscillation circuit

This circuit generates an AC voltage (pulse) in order to increase the UNREG power supply voltage when drops in current occur. This circuit generates a drive pulse with a frequency of approximately 50-100 kHz. Because self-excited light emission is used, the oscillation frequency changes according to the drive conditions.

#### 1-4. Oscillation transformer

The low-voltage alternating current which is generated by the oscillation control circuit is converted to a high-voltage alternating current by the oscillation transformer.

#### 1-5. Rectifier circuit

The high-voltage alternating current which is generated at the secondary side of T5401 is rectified to produce a high-voltage direct current and is accumulated at electrolytic capacitor C5412 on the main circuit board.

#### 1-6. Voltage monitoring circuit

This circuit is used to maintain the voltage accumulated at C5412 at a constant level.

After the charging voltage is divided and converted to a lower voltage by R5417 and R5419, it is output to the SY1 circuit board as the monitoring voltage VMONIT. When this VMONIT voltage reaches a specified level at the SY1 circuit board, the CHG signal is switched to Low and charging is interrupted.

### 2. Light Emission Circuit

When RDY and TRIG signals are input from the ASIC expansion port, the stroboscope emits light.

#### 2-1. Emission control circuit

When the RDY signal is input to the emission control circuit, Q5409 switches on and preparation is made to let current flow to the light emitting element. Moreover, when a STOP signal is input, the stroboscope stops emitting light.

#### 2-2. Trigger circuit

When a TRIG signal is input to the trigger circuit, D5405 switches on, a high-voltage pulse of several kilovolts is generated inside the trigger circuit, and this pulse is then applied to the light emitting part.

#### 2-3. Light emitting element

When the high-voltage pulse from the trigger circuit is applied to the light emitting part, current flows to the light emitting element and light is emitted.

**Beware of electric shocks.**

## 1-6. SY1 CIRCUIT DESCRIPTION

### 1. Configuration and Functions

For the overall configuration of the SY1 circuit board, refer to the block diagram. The configuration of the SY1 circuit board centers around a 8-bit microprocessor (IC301).

The 8-bit microprocessor handles the following functions.

1. Operation key input, 2. Mode LCD display, 3. Clock control, 4. Power ON/OFF, 5. Strobe charge control

Pin	Signal	I/O	Outline	
1	CHG VOL	I	Strobe charge voltage input (analog input)	
2~7	SCAN IN	I	Key matrix input	
8	AVDD	-	A/D converter analog power terminal	
9	VREF	I	A/D converter standard voltage input terminal	
10	STBY (R) LED	I	Standby LED (red) $\overline{\text{ON/OFF}}$ signal	L : LED light
11	STBY (G) LED	O	Standby LED (green) $\overline{\text{ON/OFF}}$ signal	L : LED light
12	VSS	-	GND	
13	SELF LED	O	Self-timer LED $\overline{\text{ON/OFF}}$ signal	L : LED light
14~19	NOT USED	-	-	
20	AVREF ON	O	A/D standard power $\overline{\text{ON/OFF}}$ signal	L : ON
21	BUZZER	O	Buzzer output	
22	CHG ON	O	Flash charge $\overline{\text{ON/OFF}}$ signal	H : ON
23~30	NOT USED	-	-	
31	VSS	-	GND	
32~69	NOT USED	-	-	
70	P (A) ON	O	DC/DC converter (analog) $\overline{\text{ON/OFF}}$ signal	H : ON
71	P ON	O	DC/DC converter (digital) $\overline{\text{ON/OFF}}$ signal	H : ON
72	DIN CONNECT	I	DIN jack connect detection signal	H : Connection
73	CARD	I	Memory card attachment detection signal	L : Attachment
74	AV JACK	I	AV output cable connection detection signal	H : Connection
75	SI	I	Serial communication data input ( $\leftarrow$ ASIC)	
76	SO	O	Serial communication data output ( $\rightarrow$ ASIC)	
77	SCK	O	Serial communication clock output ( $\rightarrow$ ASIC)	
78	IC	-	Connect to GND	
79	XOUT	O	Main clock oscillation terminal	
80	XIN	I	Main clock oscillation terminal (4 MHz)	
81	VDD	-	VDD	
82	XCIN	I	Sub clock oscillation terminal	
83	XCOU	O	Sub clock oscillation terminal (32.768 kHz)	
84	RESET	I	Reset input	
85	BAT OFF	I	Battery OFF detection signal	L : OFF
86	RXD	I	RS-232C RXD input terminal	
87	S. REQ	I	Serial communication request signal	L : Request
88~90	NOT USED	-	-	
91~93	SCAN OUT0~2	O	Key matrix output	
94	WAKE UP	O	Wake up signal	H : WAKE UP
95	LCD ON	O	LCD monitor power $\overline{\text{ON/OFF}}$ signal	H : ON
96	ASIC TEST 0	O	ASIC reset control signal	
97	ASIC RESET	O	ASIC reset signal	L : Reset output
98	ASIC TEST 2	O	ASIC reset control signal	L : Reset control
99	AVSS	-	Analog GND	
100	BATTERY	I	Battery voltage input (analog input)	

Table 4-1. 8-bit Microprocessor Port Specification

## 2. Internal Communication Bus

The SY1 circuit board carries out overall control of camera operation by detecting the input from the keyboard and the condition of the camera circuits. The 8-bit microprocessor reads the signals from each sensor element as input data and outputs this data to the camera circuits (ASIC) or to the LCD display device as operation mode setting data. Fig. 4-1 shows the internal communication between the 8-bit microprocessor and ASIC.

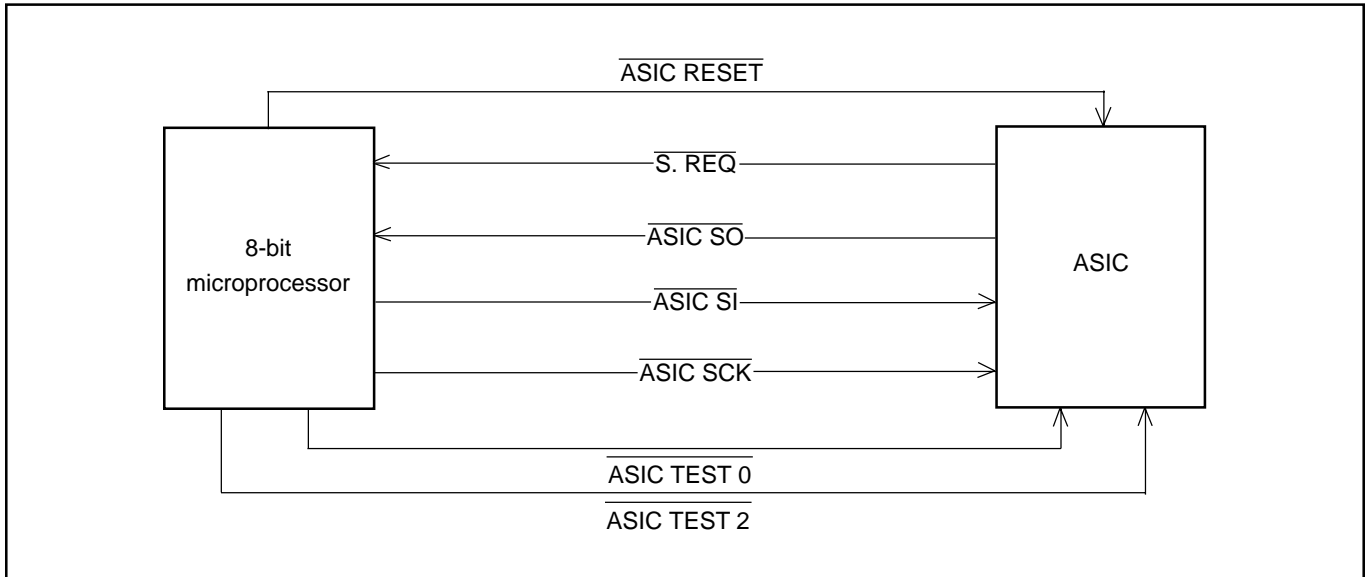

Fig. 4-1 Internal Bus Communication System

## 3. Key Operaiton

For details of the key operation, refer to the instruction manual.

SCAN OUT \ SCAN IN	0	1	2	3	4	5
0	LEFT	UP	RIGHT	DOWN	MODE	SET
1	SEQUENTIAL SHOT	SHOOTING VIDEO CLIPS	OPTION	STILL IMAGE	SHUTTER 1st	SHUTTER 2nd
2	POWER	INFO	IMAGE	PLAY	TEST	

Table 4-2. Key Operation

#### 4. Power Supply Control

The 8-bit microprocessor controls the power supply for the overall system.

The following is a description of how the power supply is turned on and off. When the battery is attached, a regulated 3.2 V voltage is normally input to the 8-bit microprocessor (IC301) by IC302, so that clock counting and key scanning is carried out even when the power switch is turned off, so that the camera can start up again. When the battery is removed, the 8-bit microprocessor operates in sleep mode using the backup capacitor. At this time, the 8-bit microprocessor only carries out clock counting, and waits in standby for the battery to be attached again. When a switch is operated, the 8-bit microprocessor supplies power to the system as required.

The 8-bit microprocessor first sets both the  $\overline{P(A)ON}$  signal at pin (70) and the  $\overline{PON}$  signal at pin (71) to high, and then turns on the DC/DC converter. After this, low signals are output from pins (96), (97) and (98) so that the ASIC is set to the active condition. If the LCD monitor is on, the LCD ON signal at pin (95) set to high, and the DC/DC converter for the LCD monitor is turned on. Once it is completed, the ASIC returns to the reset condition, all DC/DC converters are turned off and the power supply to the whole system is halted.

		ASIC, memory	CCD	8 bit CPU	MODE LCD	LCD MONITOR
Supply voltage		3.3 V	5 V (A) +12 V etc.	3.2 V (ALWAYS)	3.2 V (ALWAYS)	5V (L) +12V etc.
Power OFF		OFF	OFF	32KHz	OFF	OFF
CAM	Power switch ON- Auto power down	OFF	OFF	4 MHz	ON	OFF
	Shutter switch ON	ON	ON OFF	4 MHz	ON	OFF
	Resolution, Flash, Self timer switch ON	OFF	OFF	4 MHz	ON	OFF
	LCD finder	ON	ON	4 MHz	ON	ON
	Play back	ON	OFF	4 MHz	ON	ON

**Table 4-3. Camera Mode (Battery Operation)**

Note) P. SAVE = 4 MHz = Main clock operation, 32 kHz = Sub clock operation

## 2. DISASSEMBLY

### 2-1. REMOVAL OF CABINET ASSEMBLY (FRONT) AND CABINET ASSEMBLY (BACK)

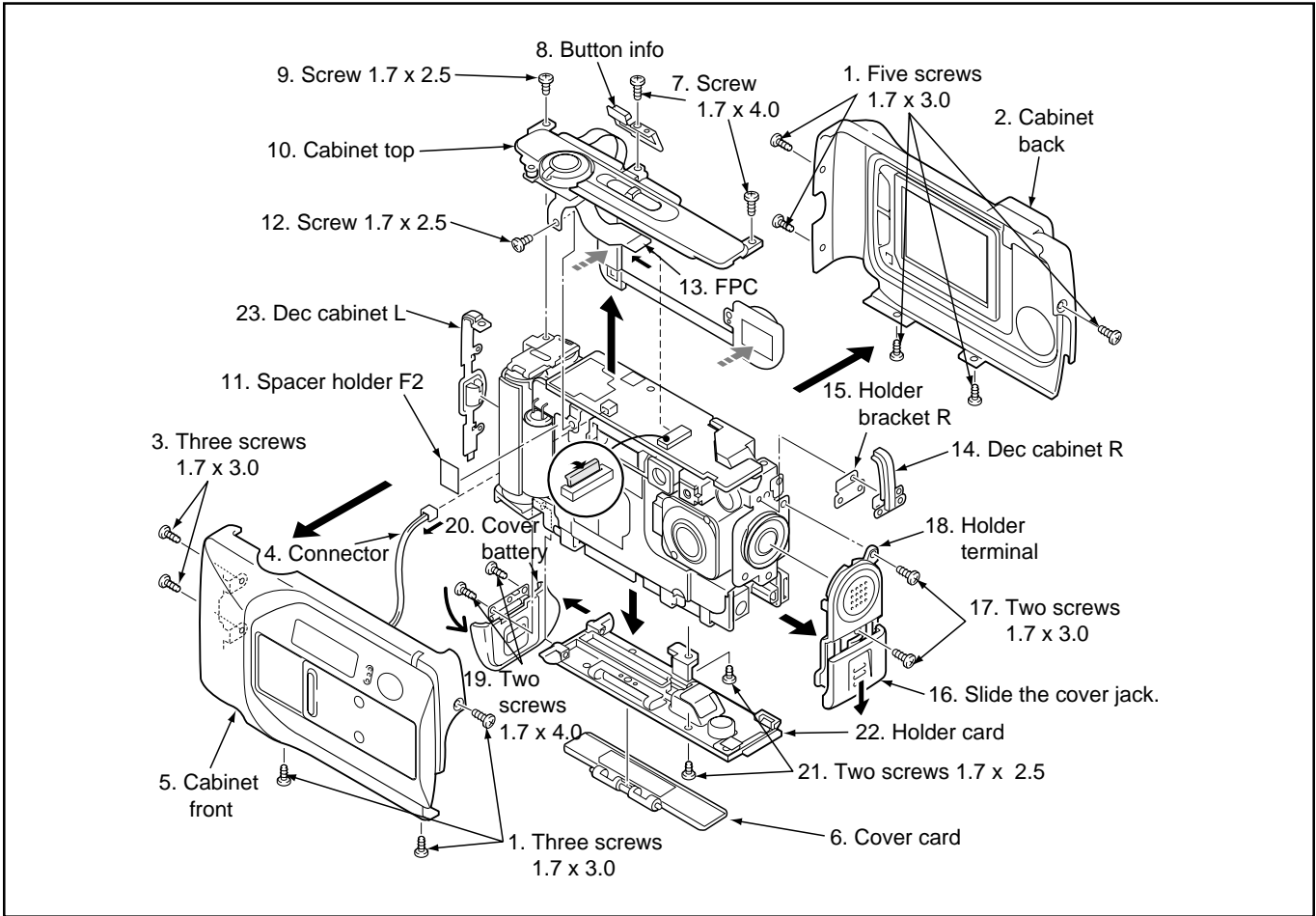

### 2-2. REMOVAL OF SY1 BOARD

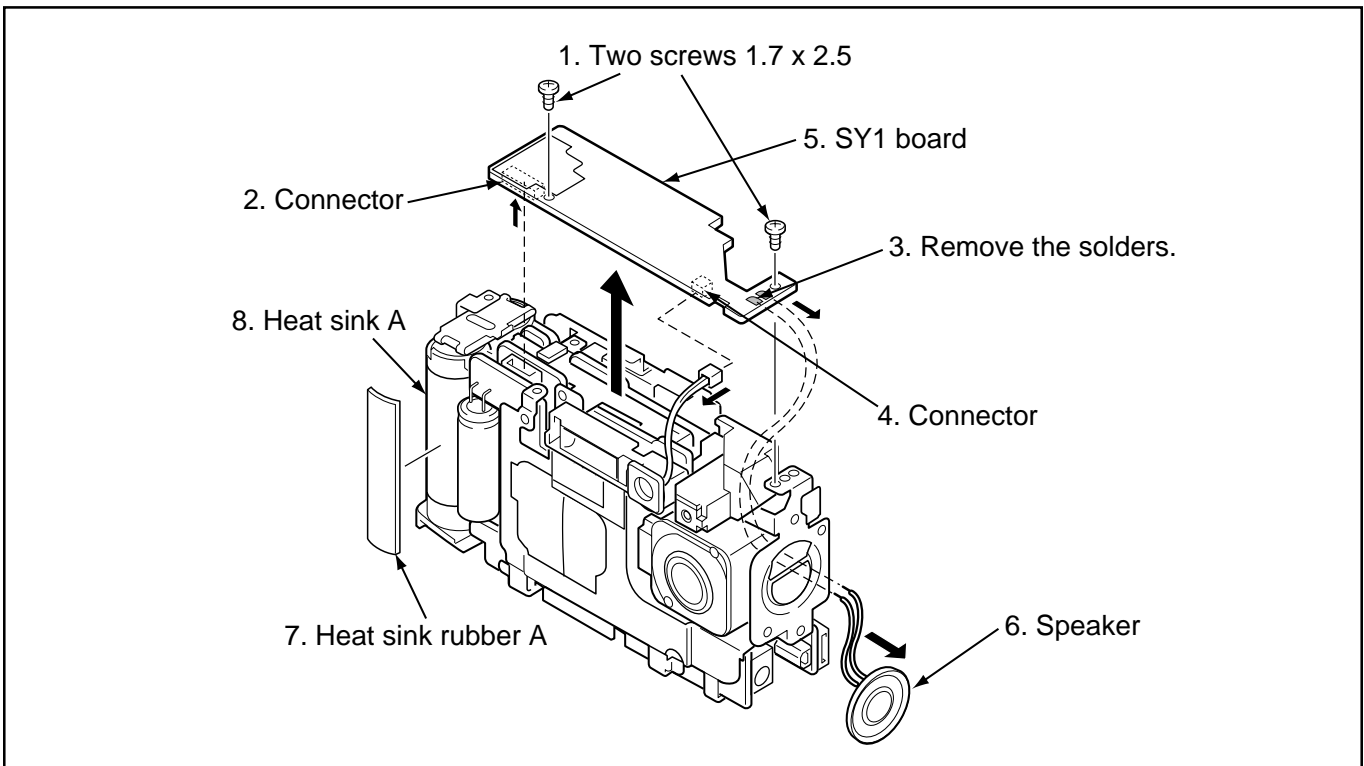

### 2-3. REMOVAL OF HOLDER BATTERY AND PW1 BOARD

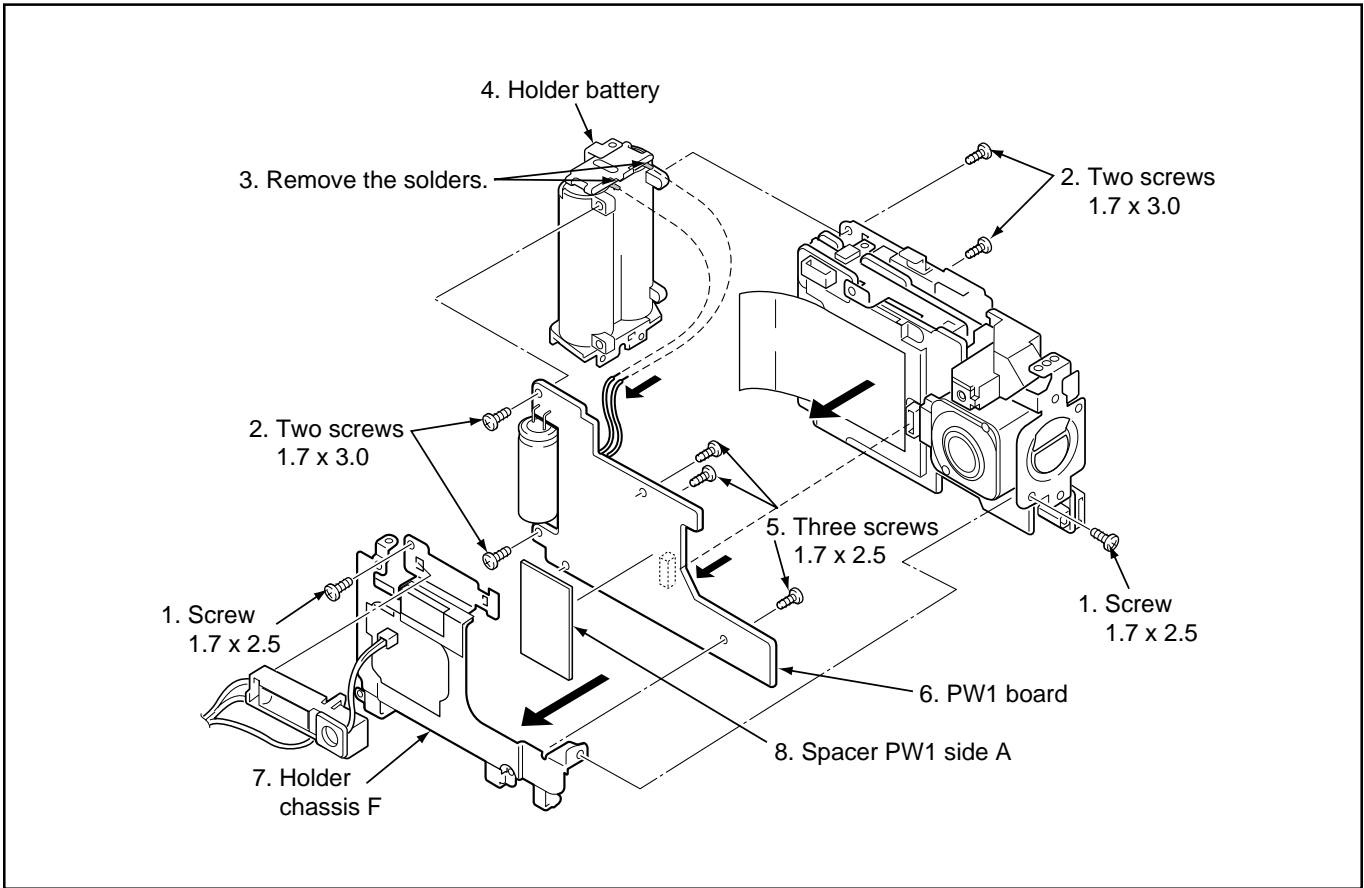

### 2-4. REMOVAL OF LCD, LENS ASSEMBLY AND CA1 BOARD

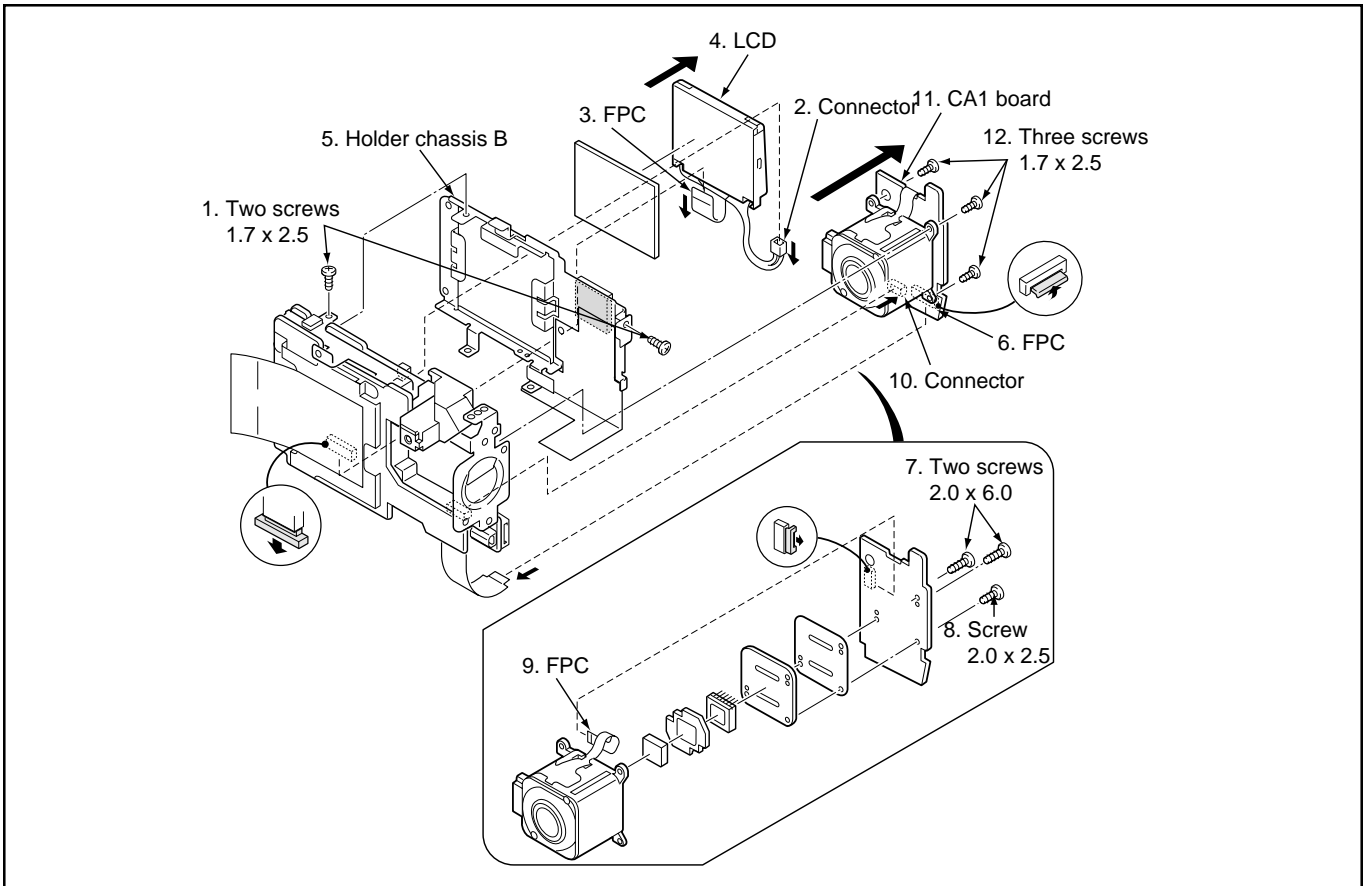

## 2-5. REMOVAL OF CA3 BOARD AND CA2 BOARD

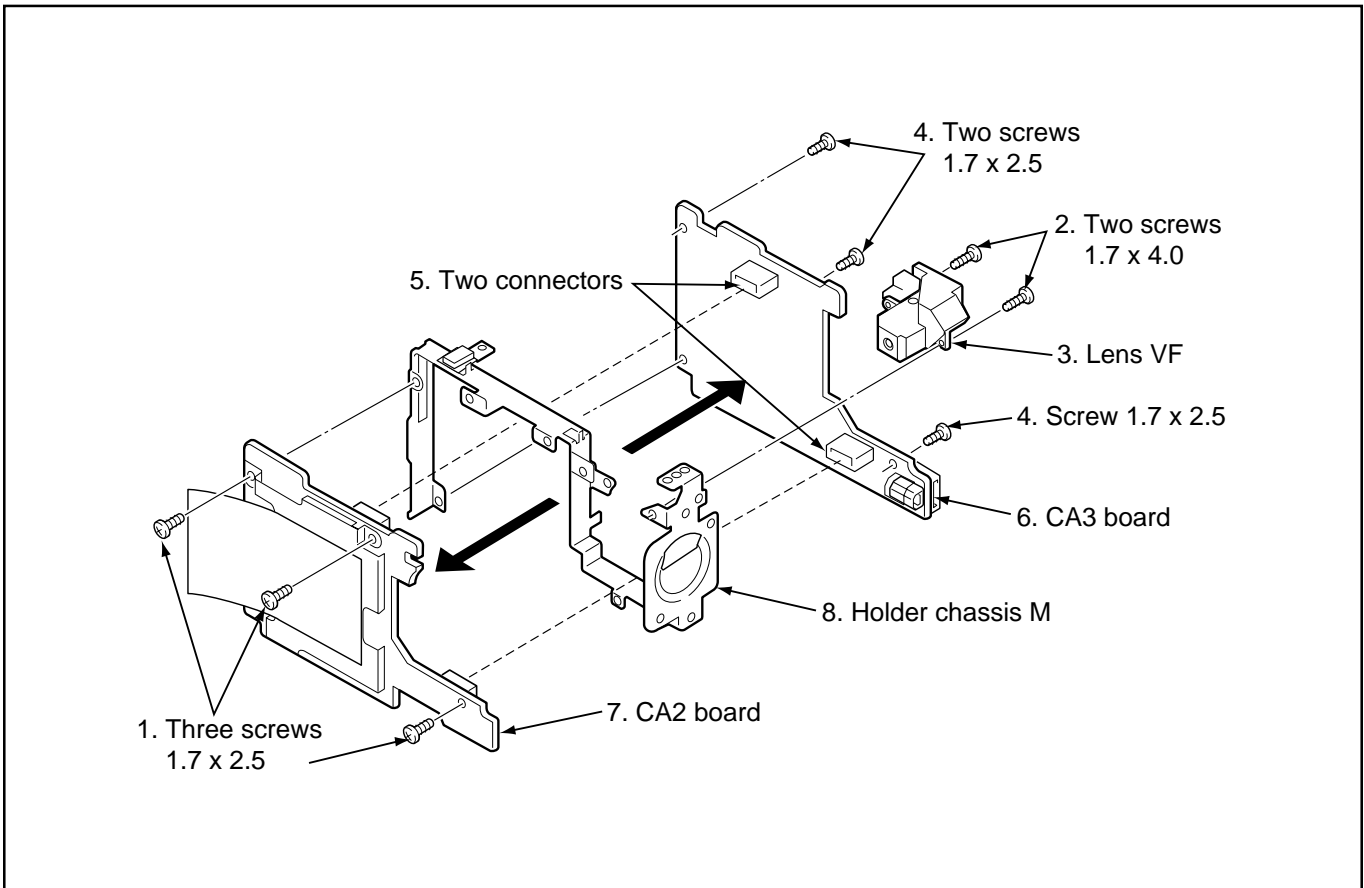

## 2-6. BOARD LOCATION

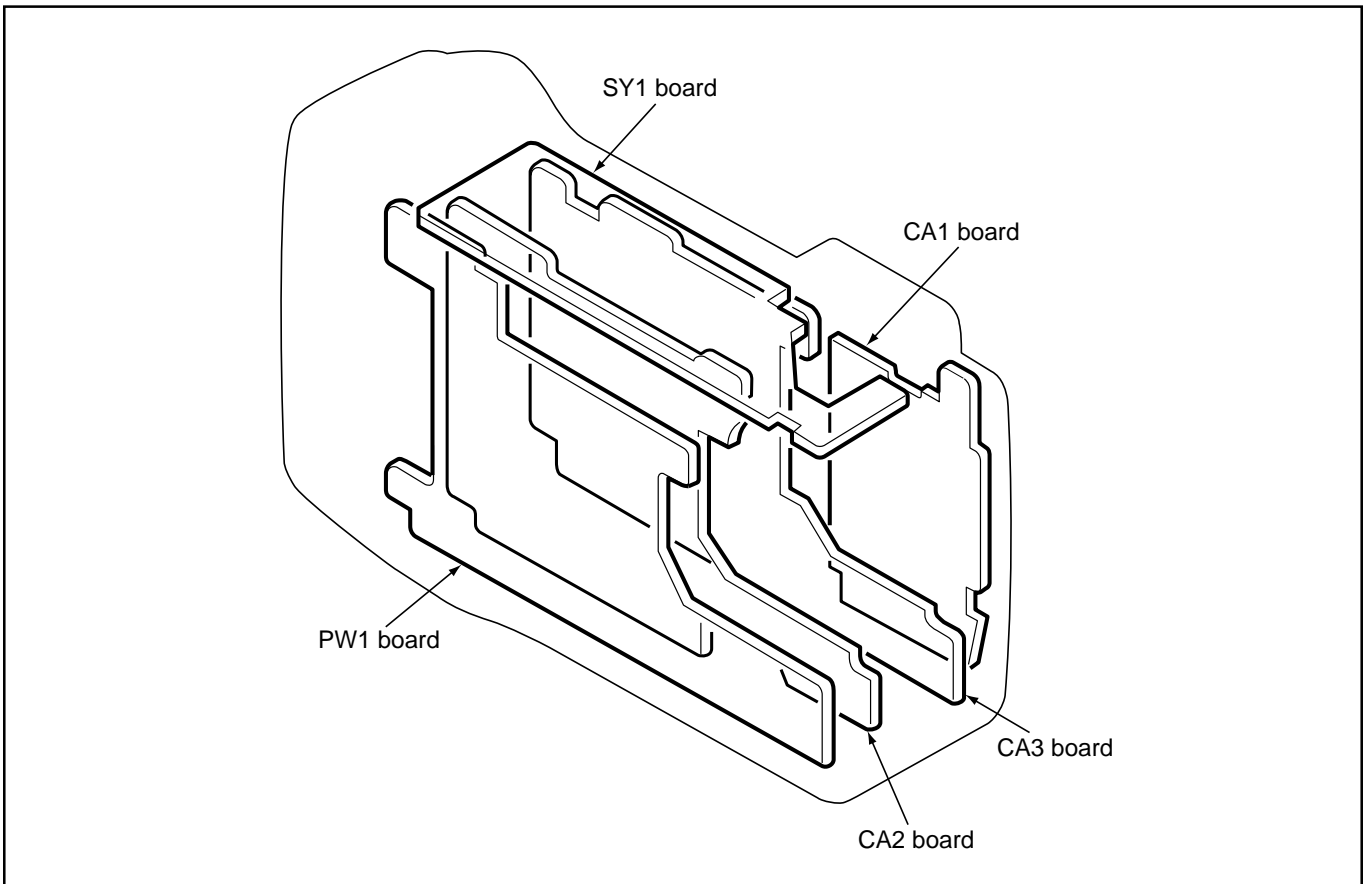

### 3. ELECTRICAL ADJUSTMENT

#### 3-1. Table for Servicing Tools

Ref. No.	Name	Part code
J-1	Color viewer 5,100 K	VJ8-0007
J-2	Siemens star chart	
J-3	Calibration software	VJ8-0175
J-4	Chart for color adjustment	VJ8-0155
J-5	Extension cord	VJ8-0164

**Note:** J-1 color viewer is 100 - 110 VAC only.

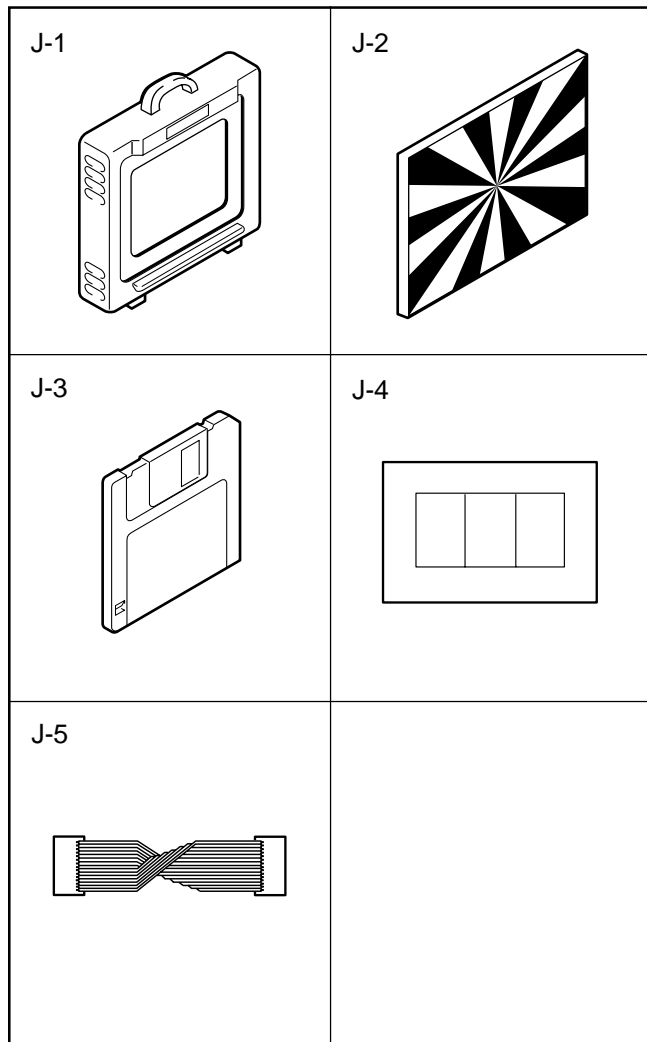

#### 3-2. Equipment

1. Oscilloscope
2. Digital voltmeter
3. AC adaptor
4. IBM R-compatible PC
5. DC regulated power supply

#### 3-3. Adjustment Items and Order

1. IC501 Oscillation Frequency Adjustment
2. 5.0 V (D) Voltage Adjustment
3. 3.3 V (D) A Voltage Adjustment
4. 3.4 V (D) B Voltage Adjustment

5. 12.4 V (L) Voltage Adjustment 1
6. 12.4 V (L) Voltage Adjustment 2
7. AWB Adjustment
8. Lens Adjustment
9. CCD Defect Detect Adjustment
10. LCD Panel Adjustment
  - 10-1. LCD H AFC Adjustment
  - 10-2. LCD RGB Offset Adjustment
  - 10-3. LCD Gain Adjustment
  - 10-4. LCD Blue Brightness Adjustment
  - 10-5. LCD Red Brightness Adjustment

**Note:** If the lens, CCD and board in item 7-9, it is necessary to adjust again. Adjustments other than these should be carried out in sequence. For 9, carry out adjustment after sufficient charging has taken place.

#### 3-4. Setup

##### 1. System requirements

- Windows 98 or Me
- IBM®-compatible PC with Pentium processor
- CD-ROM drive
- 3.5-inch high-density diskette drive
- Serial port with standard RS-232C interface or USB port
- 8 MB RAM
- Hard disk drive with at least 15 MB available
- VGA or SVGA monitor with at least 256-color display

##### 2. Installing calibration software

1. Insert the calibration software installation diskette into your diskette drive.
2. Open the explorer.
3. Copy the DSC Cal folder on the floppy disk in the FD drive to a folder on the hard disk.

##### 3. Installing USB drive

Install the USB drive with camera or connection kit for PC.

##### 4. Color Viewer

Turn on the switch and wait for 30 minutes for aging to take place before using Color Pure.

##### 5. Computer screen during adjustment

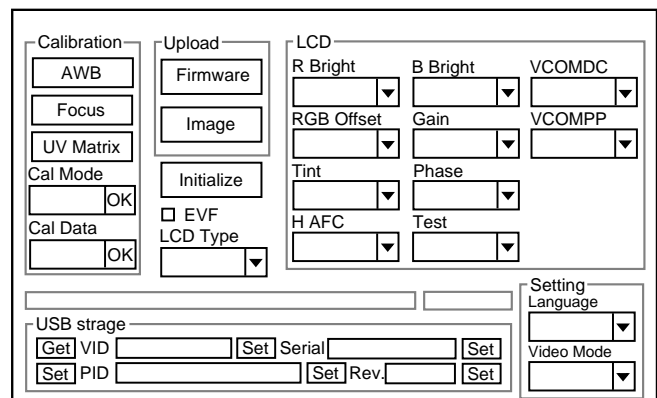



### 3-5. Connecting the camera to the computer

1. Turn off both camera and computer.
2. Line up the arrow on the serial cable connector with the notch on the camera's serial port. Insert the connector.  
In case of USB cable, line up the arrow on the USB cable connector with the notch on the camera's USB port. Insert the connector.
3. Line up the serial connector on the serial cable with the serial port on your computer, and insert the connector.  
In case of USB cable, line up the USB connector on the USB cable with the USB port on your computer, and insert the connector.
4. Turn on the camera and your computer system.

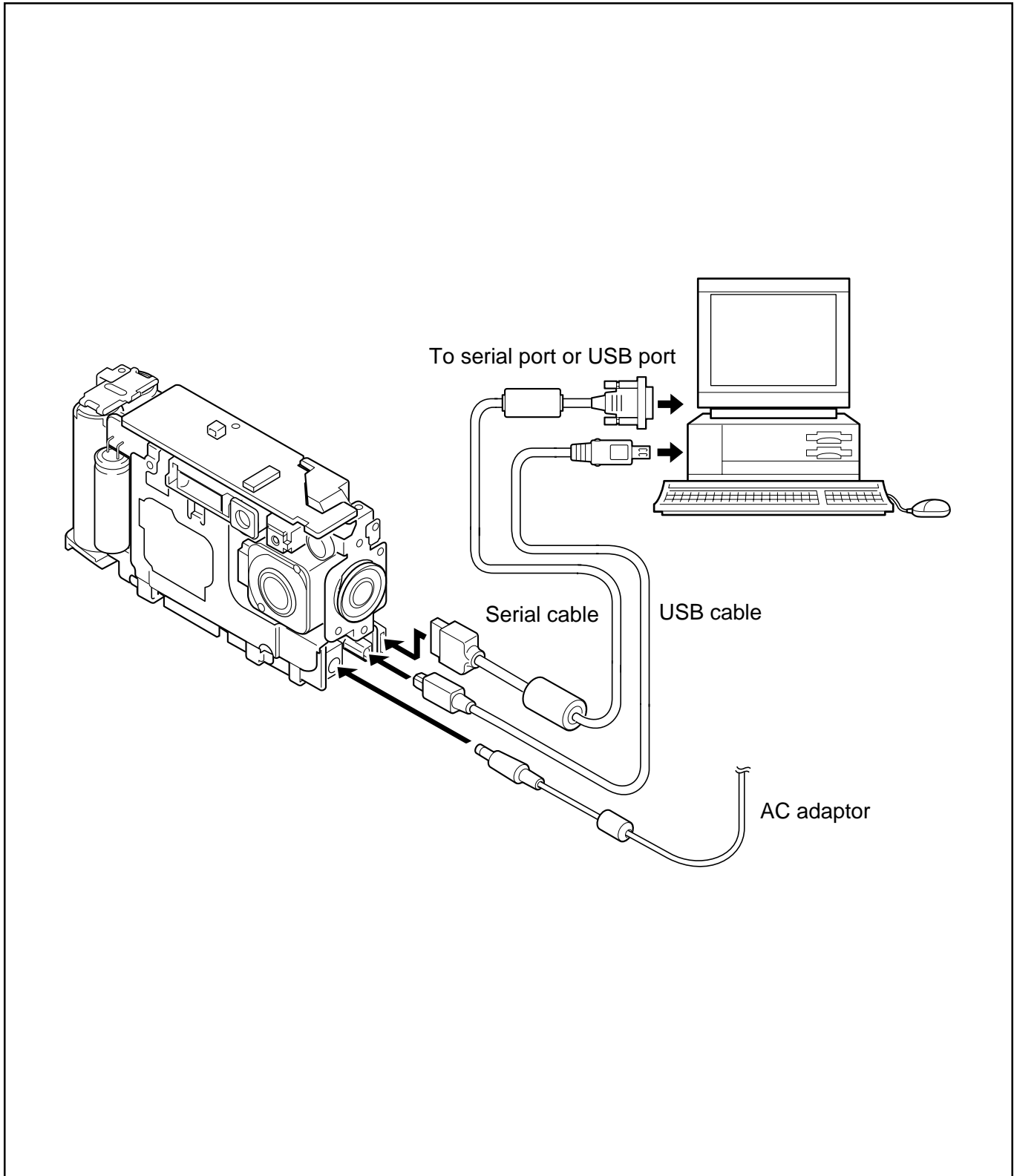

### 3-6. Adjust Specifications

[PW1 board (Side B)]

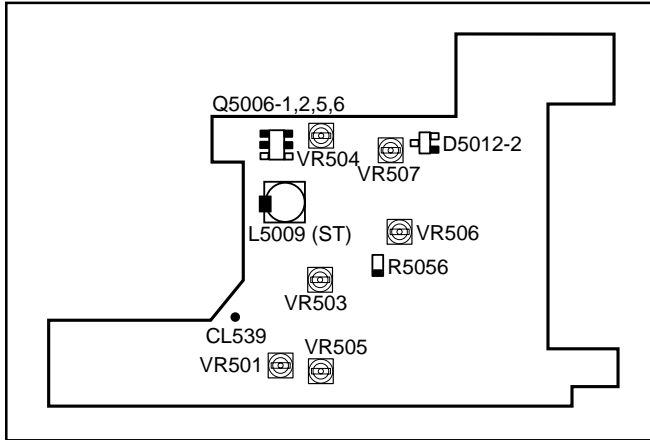

**Note:**

1. Voltage adjustment is necessary to repair in the PW1 board and replace the parts.
2. Power voltage set about +3.0 V.

**Preparation:**

1. Connect CN104 on the CA2 board and CN502 on the PW1 board with extension cord.
2. Open the barrier switch.
3. Slide the slide switch to camera, and turn on the LCD.

#### 1. IC501 Oscillation Frequency Adjustment

Measuring Point	Q5006-1, 2, 5, 6
Measuring Equipment	Frequency counter
ADJ. Location	VR501
ADJ. Value	200 ± 1 kHz

**Adjustment method:**

1. Adjust with VR501 to 200 ± 1 kHz.

#### 2. 5.0 V (D) Voltage Adjustment

Measuring Point	CL539
Measuring Equipment	Digital voltmeter
ADJ. Location	VR505
ADJ. Value	5.10 ± 0.05 V

**Adjustment method:**

1. Adjust with VR505 to 5.10 ± 0.05 V.

#### 3. 3.3 V (D) A Voltage Adjustment

Measuring Point	R5056 below
Measuring Equipment	Digital voltmeter
ADJ. Location	VR503
ADJ. Value	3.30 ± 0.02 V

**Adjustment method:**

1. Adjust with VR503 to 3.30 ± 0.02 V

### 4. 3.4 V (D) B Voltage Adjustment

Measuring Point	L5009 ST side
Measuring Equipment	Digital voltmeter
ADJ. Location	VR504
ADJ. Value	3.40 ± 0.03 V

**Adjustment method:**

1. Adjust with VR504 to 3.40 ± 0.03 V.

### 5. 12.4 V (L) Voltage Adjustment 1

Measuring Point	D5012-2
Measuring Equipment	Digital voltmeter
ADJ. Location	VR507
ADJ. Value	12.40 ± 0.05 V

**Adjustment method:**

1. Set the play mode.
2. Adjust with VR507 to 12.40 ± 0.05 V.

### 6. 12.4 V (L) Voltage Adjustment 2

Measuring Point	D5012-2
Measuring Equipment	Digital voltmeter
ADJ. Location	VR506
ADJ. Value	12.40 ± 0.05 V

**Adjustment method:**

1. Set the view mode, and turn on the LCD.
2. Adjust with VR506 to 12.40 ± 0.05 V.

### 7. AWB Adjustment

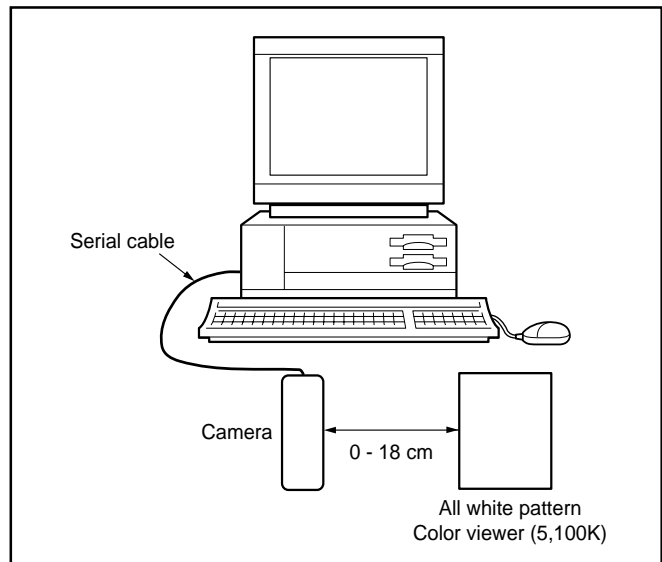

**Preparation:**

POWER switch: ON

**Adjusting method:**

1. When setting the camera in place, set it to an angle so that nothing appears in any part of the color viewer except the white section. (Do not enter any light.)
2. Double-click on the DscCalDi126.
3. Click the AWB, and click the Yes.

4. AWB adjustment value will appear on the screen.
5. Click the OK.

### 8. Lens Adjustment

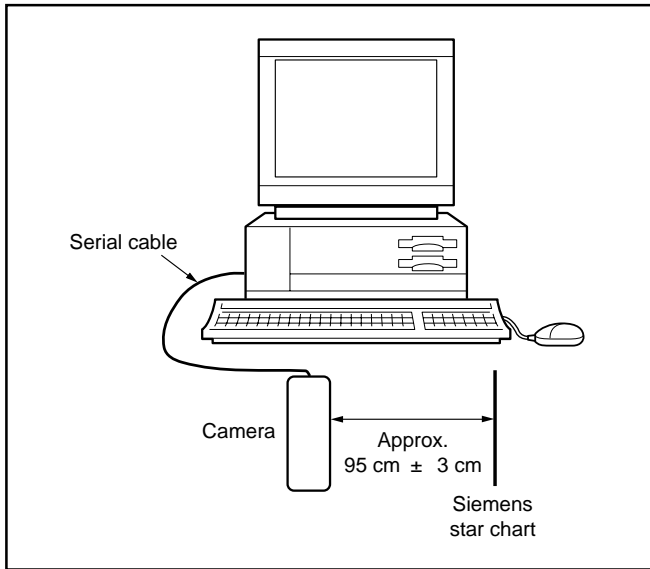

**Preparation:**

POWER switch: ON

**Adjustment condition:**

More than A3 size siemens star chart  
 Fluorescent light illumination with no flicker  
 Illumination above the subject should be 400 lux ± 10 %.

**Adjustment method:**

1. Set the siemens star chart 95 cm ± 3 cm so that it becomes center of the screen.
2. Double-click on the DscCalDi126.
3. Click the Focus, and click the Yes.
4. Lens adjustment value will appear on the screen.
5. Click the OK.

### 9. CCD Defect Detect Adjustment

**Preparation:**

POWER switch: ON (Set the camera mode.)

**Adjustment method:**

1. Double-click on the DscCalDi126.
2. Select CCD Defect Detection on the LCD "Test", and click the "Yes".
3. After the adjustment is completed, OK will display.
4. Click the OK.

### 10. LCD Panel Adjustment [CA3 board (Side A)]

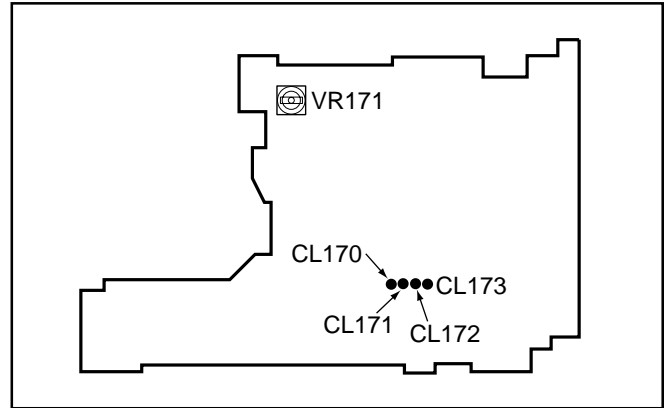

#### 10-1. LCD H AFC Adjustment

**Preparation:**

POWER switch: ON

**Adjusting method:**

1. Double-click on the DscCalDi126.
2. Select 0 on the LCD "H AFC".
3. Apply the trigger at CL173, and adjust VR171 so that the time A from the point where the pulse at CL170 rises until the position where the video signal at CL173 starts in 0.82 ± 0.1 μsec (for VPC-SX560EX and VPC-SX560E) or 1.5 ± 0.1 μsec (for VPC-SX560).

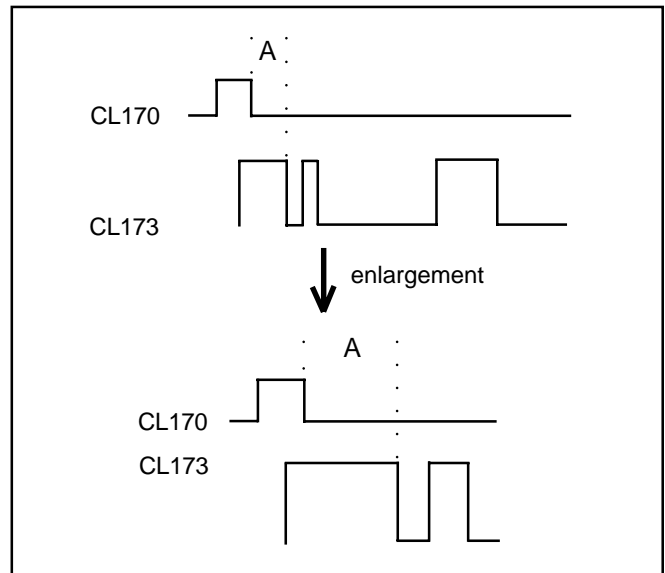

## 10-2. LCD RGB Offset Adjustment

### Adjusting method:

1. Adjust LCD "RGB offset" so that the amplitude of the CL173 waveform is  $7.3\text{ V} \pm 0.3\text{ Vp-p}$ .

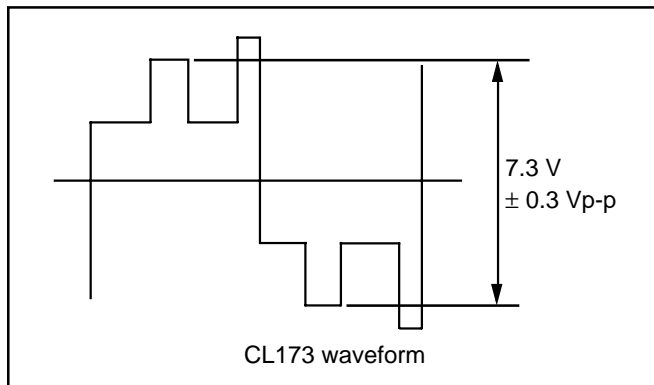

## 10-3. LCD Gain Adjustment

### Adjusting method:

1. Adjust LCD "Gain" so that the amplitude of the CL173 waveform is  $4.0\text{ V} \pm 0.1\text{ Vp-p}$ .

### Note:

10-2. LCD RGB Offset adjustment should always be carried out first.

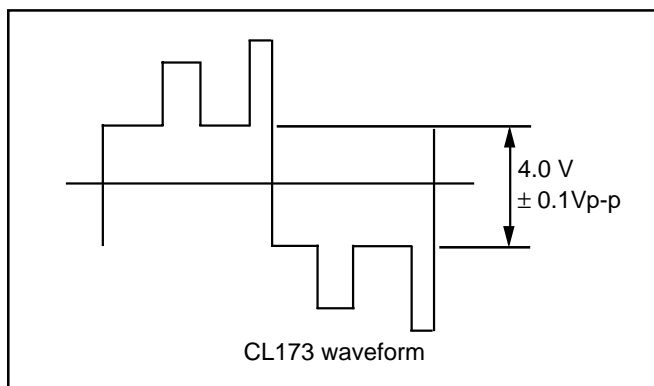

## 10-4. LCD Blue Brightness Adjustment

### Adjusting method:

1. Adjust LCD "B Bright" so that the amplitude of the CL171 waveform is  $VG + 0.2 \pm 0.05\text{ Vp-p}$  with respect to the CL173 (VG) waveform.

### Note:

10-2. LCD RGB Offset adjustment and 10-3. LCD Gain adjustment should always be carried out first.

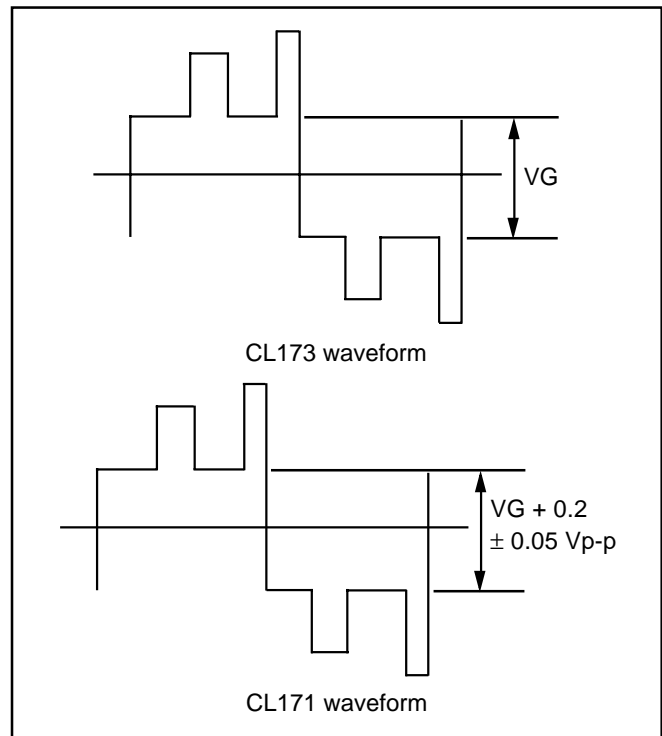

## 10-5. LCD Red Brightness Adjustment

### Adjusting method:

1. Adjust LCD "R Bright" so that the amplitude of the CL172 waveform is  $VG - 0.1 \pm 0.05\text{ Vp-p}$  with respect to the CL173 (VG) waveform.

### Note:

10-2. LCD RGB Offset adjustment and 10-3. LCD Gain adjustment should always be carried out first.

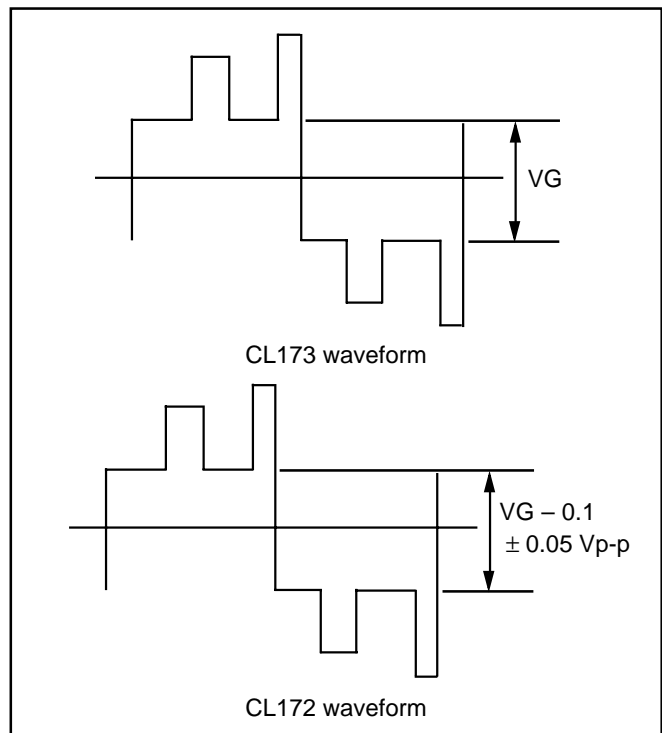

## 4. USB STORAGE INFORMATION REGISTRATION

USB storage data is important for when the camera is connected to a computer via a USB connection.

If there are any errors in the USB storage data, or if it has not been saved, the USB specification conditions will not be satisfied, so always check and save the USB storage data.

### Preparation:

POWER switch: ON

### Adjustment method:

1. Connect the camera to a computer. (Refer to 3-5. Connecting the camera to the computer on the page 17.)
2. Double-click on the DscCalDi126.
3. Click on the Get button in the USB storage window and check the USB storage data.  
 VID: SANYO  
 PID: VPC-SX560EX or VPC-SX560E or VPC-SX560  
 Serial:  
 Rev. : 1.00
4. Check the "Serial" in the above USB storage data. If the displayed value is different from the serial number printed on the base of the camera, enter the number on the base of the camera. Then click the Set button.
5. Next, check VID, PID and Rev. entries in the USB storage data. If any of them are different from the values in 3. above, make the changes and then click the corresponding Set button.

<b>Calibration</b> AWB Focus UV Matrix Cal Mode <input type="text"/> OK Cal Data <input type="text"/> OK		<b>Upload</b> Firmware Image Initialize <input type="checkbox"/> EVF LCD Type <input type="text"/>		<b>LCD</b> R Bright <input type="text"/> B Bright <input type="text"/> VCOMDC <input type="text"/> RGB Offset <input type="text"/> Gain <input type="text"/> VCOMPP <input type="text"/> Tint <input type="text"/> Phase <input type="text"/> H AFC <input type="text"/> Test <input type="text"/>		
USB storage <input type="button" value="Get"/> VID <input type="text"/> <input type="button" value="Set"/> Serial <input type="text"/> <input type="button" value="Set"/> <input type="button" value="Set"/> PID <input type="text"/> <input type="button" value="Set"/> Rev. <input type="text"/> <input type="button" value="Set"/>					<b>Setting</b> Language <input type="text"/> Video Mode <input type="text"/>	

## 5. TROUBLESHOOTING GUIDE

### POWER LOSS INOPERATIVE

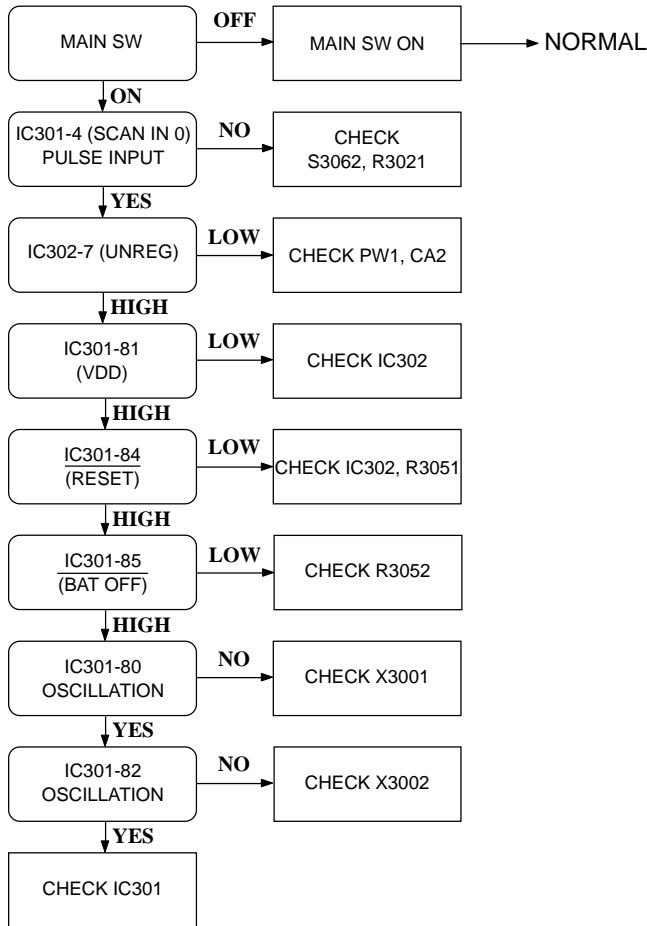

### TAKING INOPERATIVE

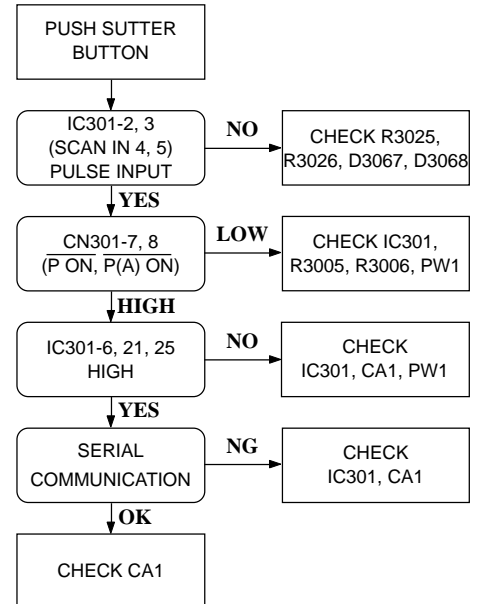

### NO PICTURE

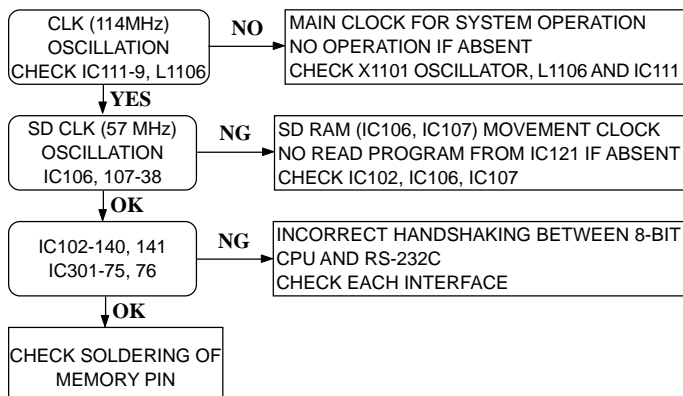

# 6. PARTS LIST

LOCATION	PARTS NO.	DESCRIPTION	LOCATION	PARTS NO.	DESCRIPTION
<b>CABINET &amp; CHASSIS PARTS 1</b>					
1	636 059 9901	ASSY,COVER LENS A-SX114EX	23	411 018 1802	SCR PAN PCS 1.7X2.5
2	636 057 8296	ASSY,CABI FRONT-SX113/J	24	636 057 5233	HOLDER CARD-SX113/J
3	411 018 2304	SCR PAN PCS 1.7X3	25	636 057 8371	COMPL,COVER BATT-SX113/J
4	636 057 8456	CABINET FRONT-SX113/J	26	636 054 7216	SPRING P COVER-SX112/J
5	636 059 4760	SPACER POWER SW-SX113/J	27	411 177 8407	SCR S-TPG PAN PCS 1.7X3
6	636 057 8524	DEC FLASH-SX113/J	28	636 058 2378	SHIELD TAPE
7	636 056 2639	DEC VF-SX112/J	29	636 058 7762	SHIELD TAPE
8	636 057 8500	DEC LENS-SX113/J	30	636 058 1180	SPACER HOLDER F2-SX112/J
9	411 177 6502	SCR S-TPG PAN PCS 1.7X4	31	636 056 2523	HEAT SINK RUBBER A-SX112/J
10	645 024 7613	SWITCH,LEAF 1P-1T	32	636 054 7186	SHAFT STRAP-SX112/J
11	636 057 2843	SPACER POWER SW-SX112/J	33	636 057 8531	DEC CABINET L-SX114/J
12	636 054 6820	CABINET INNER-SX112/J	34	636 057 8487	COVER JACK-SX113/J
13	636 054 6912	DEC SELF-SX112/J	35	636 057 5226	HOLDER TERMINAL-SX113/J
14	636 058 7595	SPRING COVER LENS-SX112/J	36	636 054 6998	HOLDER BRKT R-SX112/J
15	636 054 7056	HOLDER COVER LENS-SX112/J	37	636 057 8548	DEC CABINET R-SX114/J
16	412 060 7101	SPECIAL SCREW-1.4X2.0	38	645 043 5836	UNIT,CONTROL PANEL-SX114
17	636 056 5357	SPACER MONITOR-SX112/J	39	636 056 2530	HEAT SINK RUBBER B-SX112/J
18	636 059 9932	CABINET BACK-SX114/EX	40	411 179 0300	SCR S-TPG PAN PCS 1.7X2.5
19	636 057 8982	DEC MONITOR-SX113/U	41	636 054 7209	SLIDE KNOB POWER-SX112/J
20	636 059 8447	HOLDER VF-SX114/J	42	636 059 8386	CABINET TOP-SX114/J
21	636 057 8494	COVER CARD-SX113/J	43	411 018 3707	SCR PAN PCS 1.7X4
22	636 056 0505	LABEL COVER CARD-SX112/J	44	636 054 6790	BUTTON INFO-SX112/J
			45	636 059 8454	KNOB POWER-SX114/J
			46	636 056 0239	ASSY,WIRE POWER SW (N.S.P.)

**N.S.P.: Not available as service parts.**

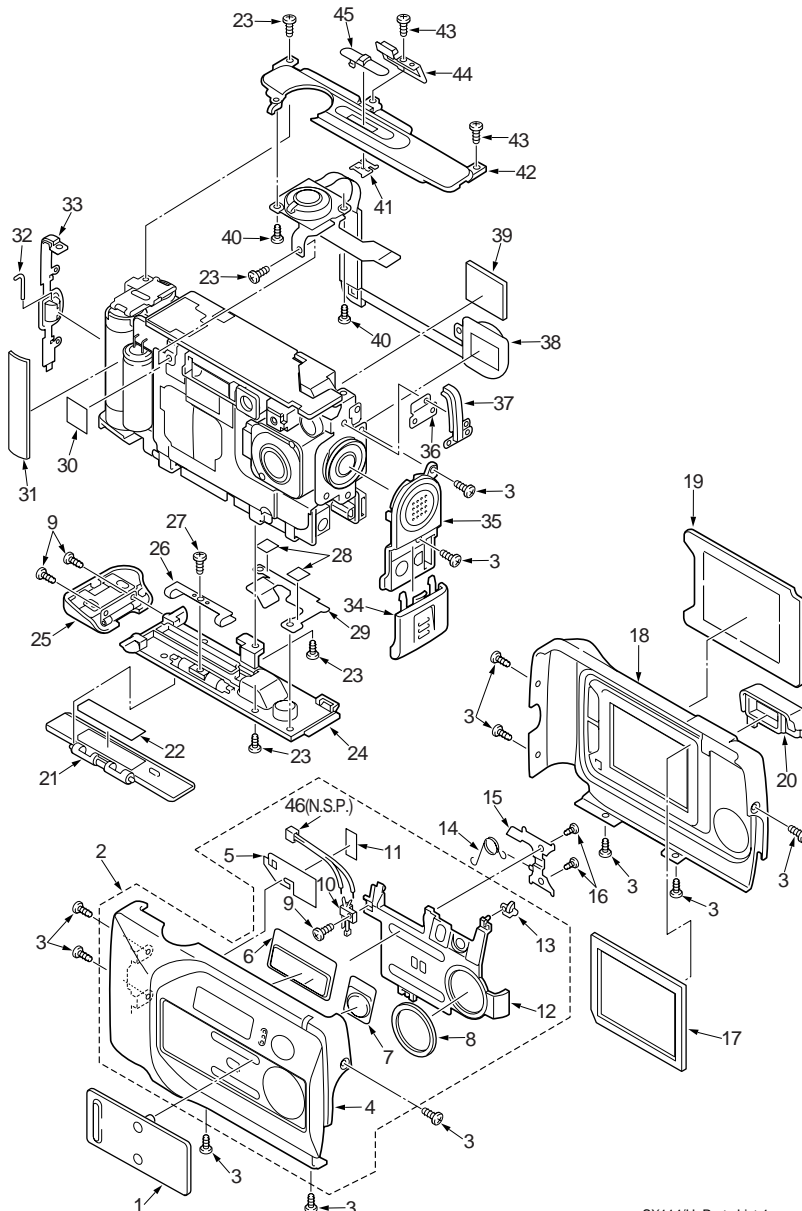

SX114/U Parts List-1

LOCATION	PARTS NO.	DESCRIPTION	LOCATION	PARTS NO.	DESCRIPTION
<b>CABINET &amp; CHASSIS PARTS 2</b>					
1	645 035 4458	LENS(ASSY)	25	636 054 7025	HOLDER CHASSIS M-SX112/J
2	411 018 1802	SCR PAN PCS 1.7X2.5	26	636 056 2646	SPACER CHASSIS M-SX112/J
3	645 038 1751	OPTICAL FILTER	27	636 059 2322	COMPL PWB,CA-3,VPC-SX560 ONLY
4	636 053 9181	SPACER	27	636 059 7631	COMPL PWB,CA-3,EXCEPT VPC-SX560
5	409 471 7202	IC ICX267AK-B	28	636 056 2653	SPACER LENS-SX112/J
6	636 053 9174	MOUNTING,LENS	29	636 056 2615	ADHESIVE TAPE VF-SR661/J
7	636 053 9198	SPACER INSULATOR	30	411 018 3707	SCR PAN PCS 1.7X4
8	636 059 7662	COMPL PWB,CA-1	31	645 028 1457	ASSY,LENS,VF
9	411 038 9000	SCR PAN 2X2.5	32	636 054 7155	REFLECTOR POWER-SX112/J
10	411 022 7807	SCR S-TPG PAN 2X6	33	636 055 4658	LABEL CAUTION BATT-SX112/J
11	636 057 7817	SPACER FLASH-SX112/J	34	636 054 6974	HOLDER SP HOOK-SX112/J
12	636 057 1686	SPACER HOLDER F1-SX112/J	35	636 049 6026	SPRING BATTERY-SR6/J
13	636 056 4930	HOLDER CHASSIS F-SX112/J	36	636 057 5219	HOLDER BATTERY R-SX113/J
14	636 056 1953	SPACER HOLDER F4-SX112/J	37	636 054 6981	HOLDER BRKT L-SX112/J
15	645 040 5976	MICROPHONE	38	636 054 7100	HOLDER BATTERY L-SX112/J
16	645 036 6680	ASSY,LAMP,SX112/J	39	636 058 6611	TERMINAL BATT B-SX113/J
17	636 057 5202	HOLDER FLASH-SX113/J	40	636 058 6598	TERMINAL BATT A-SX113/J
18	411 177 8407	SCR S-TPG PAN PCS 1.7X3	41	636 055 5211	HOLDER TERMINAL-SX112/E
19	636 057 1679	SPACER PW1 SIDE A-SX112/J	42	636 056 5494	HOLDER P BATT A-SX112/J
20	636 059 7709	COMPL PWB,PW-1	43	636 054 8367	ASSY,HOLDER P BATT B-112J
21	636 055 3286	FLEXIBLE PWB,SX112	44	636 059 2315	COMPL PWB,SY-1
22	636 059 7655	COMPL PWB,CA-2,VPC-SX560 ONLY	45	636 057 1020	SPACER SY1-SX112/J
22	636 059 7686	COMPL PWB,CA-2,EXCEPT VPC-SX560	46	636 058 2576	SHIELD TAPE
23	636 056 0277	SPACER SPEAKER B-SX112/J	47	636 058 9650	SHIELD TAPE-SX113/J
24	645 036 6277	SPEAKER,8	48	636 054 7032	HOLDER CHASSIS B-SX112/J
			49	645 040 3392	LCD(ALP228CGXB0)
			50	636 060 4599	SPACER LCD HOLDER-SX114/J

**N.S.P.: Not available as service parts.**

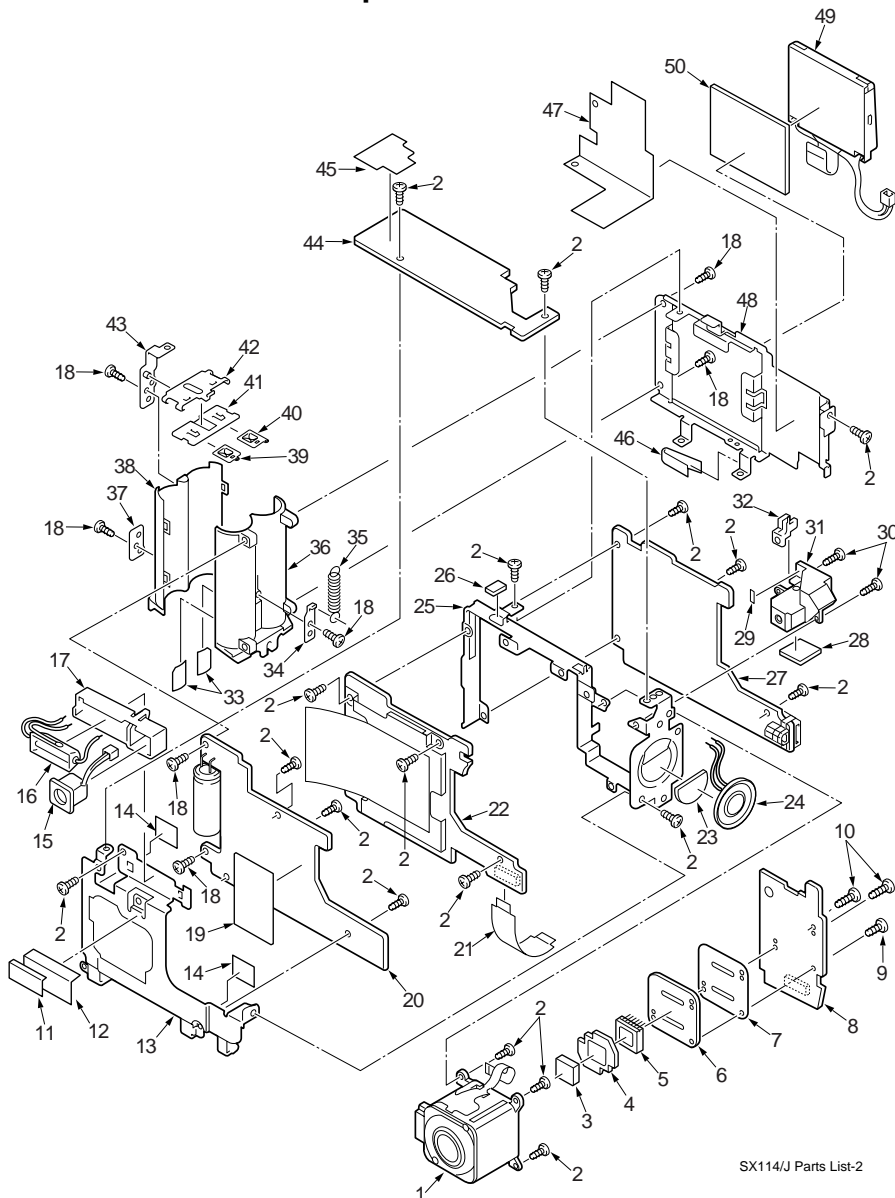

SX114/J Parts List-2



# ELECTRICAL PARTS

Note:

1. Materials of Capacitors and Resistors are abbreviated as follows ;

**Resistors**

**MT-FILM** Metallized Film Resistor  
**MT-GLAZE** Metallized Glaze Resistor  
**OXIDE-MT** Oxide Metallized Film Resistor

**Capacitors**

**MT-POLYEST** Metallized Polyester Capacitor  
**MT-COMPO** Metallized Composite Capacitor  
**TA-SOLID** Tantalum Solid Capacitor  
**AL-SOLID** Aluminum Solid Capacitor  
**NP-ELECT** Non-Polarized Electrolytic Capacitor  
**OS-SOLID** Aluminum Solid Capacitors with Organic Semiconductive Electrolytic Capacitor  
**DL-ELECT** Double Layered Electrolytic Capacitor

2. Tolerance of Capacitor (10pF over) and Resistor are noted with follow symboles.

F .....1%      G .....2%      J .....5%      K .....10%  
M .....20%      N .....30%      Z .....+80% ~ -20%

3. Capacitors

U :  $\mu$ F      P : pF

4. Inductors

UH :  $\mu$ H      MH : mH

5. N.S.P. : Not available as service parts.

LOCATION	PARTS NO.	DESCRIPTION	LOCATION	PARTS NO.	DESCRIPTION
<b>COMPL PWB,CA-1</b>			C9127	403 276 1007	CERAMIC 0.01U K 16V
	636 059 7662		C9130	403 322 1005	CERAMIC 0.1U Z 16V
			C9131	403 283 6309	CERAMIC 1U Z 10V
			C9132	403 276 1007	CERAMIC 0.01U K 16V
			C9133	403 283 6309	CERAMIC 1U Z 10V
			C9134	403 276 1007	CERAMIC 0.01U K 16V
			C9135	403 276 1007	CERAMIC 0.01U K 16V
			C9136	403 322 1005	CERAMIC 0.1U Z 16V
			C9137	403 276 1007	CERAMIC 0.01U K 16V
			C9139	403 322 1005	CERAMIC 0.1U Z 16V
			C9140	403 276 1007	CERAMIC 0.01U K 16V
			C9141	403 283 6309	CERAMIC 1U Z 10V
			C9142	403 322 1005	CERAMIC 0.1U Z 16V
			C9143	403 276 1007	CERAMIC 0.01U K 16V
			C9144	403 345 4304	TA-SOLID 22U M 10V
			C9146	403 283 6309	CERAMIC 1U Z 10V
			C9147	403 283 6309	CERAMIC 1U Z 10V
			C9148	403 276 1007	CERAMIC 0.01U K 16V
			C9149	403 320 5302	CERAMIC 0.15U K 25V
			C9150	403 296 1308	TA-SOLID 10U M 20V
			C9151	403 322 1005	CERAMIC 0.1U Z 16V
			C9152	403 322 1005	CERAMIC 0.1U Z 16V
			C9153	403 322 1005	CERAMIC 0.1U Z 16V
			C9154	403 322 1005	CERAMIC 0.1U Z 16V
			C9155	403 322 1005	CERAMIC 0.1U Z 16V
			C9156	403 276 1007	CERAMIC 0.01U K 16V
			C9157	403 283 6309	CERAMIC 1U Z 10V
			C9158	403 276 1007	CERAMIC 0.01U K 16V
			C9159	403 276 1007	CERAMIC 0.01U K 16V
			C9160	403 329 6508	TA-SOLID 10U M 6.3V
			C9161	403 343 3101	CERAMIC 1U K 6.3V
			C9687	403 322 1005	CERAMIC 0.1U Z 16V
			C9688	403 322 1005	CERAMIC 0.1U Z 16V
			C9689	403 284 7800	CERAMIC 0.047U Z 16V
			C9690	403 322 1005	CERAMIC 0.1U Z 16V
			C9691	403 322 1005	CERAMIC 0.1U Z 16V
			C9692	403 345 4304	TA-SOLID 22U M 10V
			C9693	403 322 1005	CERAMIC 0.1U Z 16V
			C9694	403 279 5101	CERAMIC 3300P K 50V
			C9695	403 276 1007	CERAMIC 0.01U K 16V
			C9696	403 276 1007	CERAMIC 0.01U K 16V
			C9697	403 276 1007	CERAMIC 0.01U K 16V
			C9698	403 322 1005	CERAMIC 0.1U Z 16V
			C9699	403 322 1005	CERAMIC 0.1U Z 16V
			<b>(RESISTORS)</b>		
			R9002	401 226 1503	MT-GLAZE 0.000 ZA 1/16W
			R9003	401 225 1801	MT-GLAZE 47 JA 1/16W
			R9005	401 226 1503	MT-GLAZE 0.000 ZA 1/16W
			R9006	401 240 9004	MT-GLAZE 3.9 JA 1/16W
			R9010	401 226 1503	MT-GLAZE 0.000 ZA 1/16W
			R9011	401 224 9709	MT-GLAZE 22 JA 1/16W
			R9012	401 224 9709	MT-GLAZE 22 JA 1/16W
			R9013	401 224 8900	MT-GLAZE 100K JA 1/16W
Q9001	405 153 6709	TR 2SC3931-D			
Q9002	405 102 5609	TR 2SD1819A-R			
OR	405 092 4101	TR 2SC4081-R			
Q9003	405 102 5609	TR 2SD1819A-R			
OR	405 092 4101	TR 2SC4081-R			
Q9004	405 115 5108	TR 2SA1774 R			
Q9041	405 133 8907	TR DTC114EUA			
Q9501	405 131 3607	TR DTA144EUA			
Q9503	405 129 3107	TR UMD3N			
<b>(INTEGRATED CIRCUITS)</b>					
IC902	409 428 1901	IC TC74ACT04FT			
IC904	409 428 1901	IC TC74ACT04FT			
IC905	409 471 1507	IC AD9840JST			
IC907	409 446 8708	IC CXD3400N			
IC908	409 428 1901	IC TC74ACT04FT			
IC909	409 407 0505	IC TK11331BM			
IC951	409 286 9309	IC LB1843V			
IC952	409 215 6805	IC LB1638M			
IC953	409 451 8700	IC MPC17AT85MTA			
<b>(DIODES)</b>					
D9001	407 198 9905	DIODE MA727			
D9002	407 113 5609	DIODE DSH015			
OR	407 134 7200	DIODE MA141K			
<b>(CAPACITORS)</b>					
C9020	403 276 1007	CERAMIC 0.01U K 16V			
C9021	403 283 6309	CERAMIC 1U Z 10V			
C9022	403 322 1005	CERAMIC 0.1U Z 16V			
C9105	403 310 0201	CERAMIC 180P J 25V			
C9106	403 310 0201	CERAMIC 180P J 25V			
C9107	403 310 0201	CERAMIC 180P J 25V			
C9108	403 310 0201	CERAMIC 180P J 25V			
C9109	403 310 0201	CERAMIC 180P J 25V			
C9110	403 310 0201	CERAMIC 180P J 25V			
C9111	403 310 0201	CERAMIC 180P J 25V			
C9112	403 322 1005	CERAMIC 0.1U Z 16V			
C9113	403 276 1007	CERAMIC 0.01U K 16V			
C9114	403 276 1007	CERAMIC 0.01U K 16V			
C9115	403 283 6309	CERAMIC 1U Z 10V			
C9116	403 322 1005	CERAMIC 0.1U Z 16V			
C9117	403 283 6309	CERAMIC 1U Z 10V			
C9118	403 322 1005	CERAMIC 0.1U Z 16V			
C9119	403 283 5708	CERAMIC 2200P K 50V			
C9120	403 283 6309	CERAMIC 1U Z 10V			
C9121	403 296 1308	TA-SOLID 10U M 20V			
C9122	403 322 1005	CERAMIC 0.1U Z 16V			
C9123	403 345 4304	TA-SOLID 22U M 10V			
C9124	403 283 6309	CERAMIC 1U Z 10V			
C9125	403 283 6309	CERAMIC 1U Z 10V			
C9126	403 283 6309	CERAMIC 1U Z 10V			



LOCATION	PARTS NO.	DESCRIPTION	LOCATION	PARTS NO.	DESCRIPTION
C1090	403 311 4505	CERAMIC 1000P K 50V	R1108	401 105 7909	MT-GLAZE 0.000 ZA 1/16W
C1091	403 311 4505	CERAMIC 1000P K 50V	R1110	401 225 2006	MT-GLAZE 680 JA 1/16W
C1093	403 311 4505	CERAMIC 1000P K 50V	R1201	401 225 8107	MT-GLAZE 10 JA 1/16W
C1101	403 329 6508	TA-SOLID 10U M 6.3V	R1202	401 037 5004	MT-GLAZE 0.000 ZA 1/10W
C1102	403 343 8700	CERAMIC 1U M 12V	R1322	401 226 1503	MT-GLAZE 0.000 ZA 1/16W
C1112	403 346 2309	CERAMIC 0.1U K 10V	R1323	401 226 1503	MT-GLAZE 0.000 ZA 1/16W
C1201	403 207 0307	CERAMIC 1U Z 16V	R1324	401 226 1503	MT-GLAZE 0.000 ZA 1/16W
C1320	403 312 6805	CERAMIC 0.1U Z 16V	R1325	401 226 1503	MT-GLAZE 0.000 ZA 1/16W
C1321	403 164 0204	CERAMIC 0.1U Z 25V	R1326	401 224 9006	MT-GLAZE 10K JA 1/16W
C1322	403 164 0204	CERAMIC 0.1U Z 25V	R1327	401 226 1503	MT-GLAZE 0.000 ZA 1/16W
C1323	403 164 0204	CERAMIC 0.1U Z 25V	R1328	401 226 1503	MT-GLAZE 0.000 ZA 1/16W
C1324	403 164 0204	CERAMIC 0.1U Z 25V	R1329	401 225 1405	MT-GLAZE 47K JA 1/16W
C1421	403 312 6805	CERAMIC 0.1U Z 16V	R1419	401 105 7909	MT-GLAZE 0.000 ZA 1/16W
C1422	403 329 6508	TA-SOLID 10U M 6.3V	R1420	401 226 1503	MT-GLAZE 0.000 ZA 1/16W
C1423	403 312 6805	CERAMIC 0.1U Z 16V	R1425	401 224 9006	MT-GLAZE 10K JA 1/16W
C1424	403 312 6805	CERAMIC 0.1U Z 16V	R1426	401 224 8900	MT-GLAZE 100K JA 1/16W
C1501	403 334 3806	CERAMIC 10U K 6.3V	R1427	401 225 1405	MT-GLAZE 47K JA 1/16W
C1508	403 311 5007	CERAMIC 33P J 50V,EXCEPT VPC-SX560	R1428	401 224 9006	MT-GLAZE 10K JA 1/16W
C1508	403 312 6508	CERAMIC 56P J 50V,VPC-SX560 ONLY	R1429	401 224 9006	MT-GLAZE 10K JA 1/16W
C1510	403 312 6805	CERAMIC 0.1U Z 16V	R1430	401 224 9006	MT-GLAZE 10K JA 1/16W
C1511	403 343 8700	CERAMIC 1U M 12V	R1432	401 224 9006	MT-GLAZE 10K JA 1/16W
C1512	403 345 3802	TA-SOLID 22U M 4V	R1433	401 224 9006	MT-GLAZE 10K JA 1/16W
C1513	403 345 4205	TA-SOLID 47U M 6.3V	R1434	401 224 9006	MT-GLAZE 10K JA 1/16W
C1517	403 312 6805	CERAMIC 0.1U Z 16V	R1507	401 261 9908	MT-FILM 91 DD 1/16W
C1519	403 329 6508	TA-SOLID 10U M 6.3V	R1508	401 261 9908	MT-FILM 91 DD 1/16W
C1521	403 312 6805	CERAMIC 0.1U Z 16V	R1509	401 261 6402	MT-FILM 200 DU 1/16W
C1602	403 345 4304	TA-SOLID 22U M 10V	R1510	401 226 2401	MT-GLAZE 560 JA 1/16W
C1603	403 329 6508	TA-SOLID 10U M 6.3V	R1511	401 226 1503	MT-GLAZE 0.000 ZA 1/16W
C1604	403 345 4205	TA-SOLID 47U M 6.3V	R1512	401 225 3805	MT-GLAZE 1.5K JA 1/16W
C1621	403 283 6309	CERAMIC 1U Z 10V	R1513	401 261 6105	MT-FILM 390 DU 1/16W
C1622	403 346 2309	CERAMIC 0.1U K 10V	R1514	401 261 5108	MT-FILM 1.0K DU 1/16W
C1623	403 283 6309	CERAMIC 1U Z 10V	R1515	401 261 5108	MT-FILM 1.0K DU 1/16W
C1625	403 319 3609	CERAMIC 330P K 50V	R1516	401 261 3807	MT-FILM 2.0K DU 1/16W
C1626	403 343 8700	CERAMIC 1U M 12V	R1519	401 225 2006	MT-GLAZE 680 JA 1/16W
	<b>(RESISTORS)</b>		R1522	401 225 3805	MT-GLAZE 1.5K JA 1/16W
R1007	401 261 4903	MT-FILM 820 DU 1/16W	R1523	401 226 5402	MT-GLAZE 56 JA 1/16W
R1008	401 261 6402	MT-FILM 200 DU 1/16W	R1525	401 226 1503	MT-GLAZE 0.000 ZA 1/16W
R1011	401 261 5108	MT-FILM 1.0K DU 1/16W	R1526	401 261 9601	MT-FILM 68 DD 1/16W
R1012	401 261 4507	MT-FILM 1.5K DU 1/16W	R1527	401 226 1503	MT-GLAZE 0.000 ZA 1/16W
R1021	401 224 9006	MT-GLAZE 10K JA 1/16W	R1530	401 226 2401	MT-GLAZE 560 JA 1/16W
R1022	401 262 3905	MT-FILM 24 DD 1/16W	R1531	401 226 2401	MT-GLAZE 560 JA 1/16W
R1023	401 225 1405	MT-GLAZE 47K JA 1/16W	R1533	401 226 1503	MT-GLAZE 0.000 ZA 1/16W
R1024	401 262 3905	MT-FILM 24 DD 1/16W	R1534	401 224 8900	MT-GLAZE 100K JA 1/16W
R1025	401 166 2905	MT-FILM 1.5K DU 1/16W	R1602	401 226 1503	MT-GLAZE 0.000 ZA 1/16W
R1031	401 225 7902	MT-GLAZE 220 JA 1/16W	R1604	401 225 1207	MT-GLAZE 4.7K JA 1/16W
R1032	401 225 7902	MT-GLAZE 220 JA 1/16W	R1605	401 225 1207	MT-GLAZE 4.7K JA 1/16W
R1033	401 225 7902	MT-GLAZE 220 JA 1/16W	R1606	401 226 1503	MT-GLAZE 0.000 ZA 1/16W
R1034	401 226 1503	MT-GLAZE 0.000 ZA 1/16W	R1607	401 224 9303	MT-GLAZE 1K JA 1/16W
R1035	401 226 1503	MT-GLAZE 0.000 ZA 1/16W	R1610	401 037 5004	MT-GLAZE 0.000 ZA 1/10W
R1036	401 226 1503	MT-GLAZE 0.000 ZA 1/16W	R1621	401 224 9006	MT-GLAZE 10K JA 1/16W
R1037	401 225 7902	MT-GLAZE 220 JA 1/16W	R1622	401 224 9006	MT-GLAZE 10K JA 1/16W
R1038	401 225 7902	MT-GLAZE 220 JA 1/16W	R1623	401 224 9006	MT-GLAZE 10K JA 1/16W
R1039	401 225 7902	MT-GLAZE 220 JA 1/16W	R1624	401 224 9204	MT-GLAZE 15K JA 1/16W
R1040	401 225 7902	MT-GLAZE 220 JA 1/16W	R1625	401 224 9501	MT-GLAZE 2.2K JA 1/16W
R1041	401 225 7902	MT-GLAZE 220 JA 1/16W	R1626	401 224 9006	MT-GLAZE 10K JA 1/16W
R1042	401 225 7902	MT-GLAZE 220 JA 1/16W	R1627	401 225 0408	MT-GLAZE 330K JA 1/16W
R1043	401 226 1503	MT-GLAZE 0.000 ZA 1/16W		<b>(CONNECTORS)</b>	
R1044	401 225 1801	MT-GLAZE 47 JA 1/16W	CN101	645 034 8150	SOCKET,FFC 39P (N.S.P)
R1045	401 225 7902	MT-GLAZE 220 JA 1/16W	CN103	645 035 5455	SOCKET,26P (N.S.P)
R1046	401 226 1503	MT-GLAZE 0.000 ZA 1/16W	CN104	645 035 5455	SOCKET,26P (N.S.P)
R1049	401 224 8900	MT-GLAZE 100K JA 1/16W	CN105	645 035 5387	PLUG,PWB-PWB 30P (N.S.P)
R1050	401 224 9006	MT-GLAZE 10K JA 1/16W	CN106	645 035 5400	PLUG,PWB-PWB 30P (N.S.P)
R1051	401 224 9006	MT-GLAZE 10K JA 1/16W	CN141	645 035 8869	PLUG,TYPE2 50P (N.S.P)
R1053	401 226 1503	MT-GLAZE 0.000 ZA 1/16W		<b>(MISCELLANEOUS)</b>	
R1055	401 224 9006	MT-GLAZE 10K JA 1/16W		636 056 5050	SPACER CF-SX112/J
R1056	401 224 9006	MT-GLAZE 10K JA 1/16W		645 035 8852	HOLDER,CF TYPE2
R1057	401 224 9006	MT-GLAZE 10K JA 1/16W	Y1001	636 056 2554	SPACER CA2 SIDE-B SX112
R1058	401 224 9006	MT-GLAZE 10K JA 1/16W	Y1201	636 056 2547	HEAT SINK RUBBER C-SX112/J
R1061	401 226 1503	MT-GLAZE 0.000 ZA 1/16W	Y1202	636 056 2516	HEAT SINK A-SX112/J
R1069	401 226 1503	MT-GLAZE 0.000 ZA 1/16W			
R1070	401 226 1503	MT-GLAZE 0.000 ZA 1/16W			
R1071	401 226 1503	MT-GLAZE 0.000 ZA 1/16W			
R1090	401 224 9006	MT-GLAZE 10K JA 1/16W			
R1091	401 224 9006	MT-GLAZE 10K JA 1/16W			
R1092	401 224 9006	MT-GLAZE 10K JA 1/16W			
R1093	401 224 9006	MT-GLAZE 10K JA 1/16W			
R1103	401 226 1503	MT-GLAZE 0.000 ZA 1/16W,VPC-SX560 ONLY			
R1104	401 226 1503	MT-GLAZE 0.000 ZA 1/16W,EXCEPT VPC-SX560			
			<b>COMPL PWB,CA-3</b>		
				636 059 2322	(VPC-SX560 ONLY)
				636 059 7631	(EXCEPT VPC-SX560)
				<b>(SEMICONDUCTORS)</b>	
			Q1701	405 102 5609	TR 2SD1819A-R
			OR	405 092 4101	TR 2SC4081-R
			Q1702	405 115 7201	TR DTC144EE

LOCATION	PARTS NO.	DESCRIPTION	LOCATION	PARTS NO.	DESCRIPTION
Q1707	405 102 5500	TR 2SB1218A-R	C1779	403 332 9503	CERAMIC 1U M 6.3V
OR	405 092 4200	TR 2SA1576-R	C5101	403 332 9503	CERAMIC 1U M 6.3V
Q5101	405 115 6907	TR DTC114EE	C5102	403 333 3708	CERAMIC 10U M 10V
Q5102	405 153 3302	TR SSM3K01F(BRA)	C5103	403 338 4403	CERAMIC 0.1U K 16V
Q5103	405 092 1100	TR 2SA1577-P	C5104	403 316 1400	CERAMIC 560P J 25V
OR	405 092 1209	TR 2SA1577-Q	C5105	403 333 3708	CERAMIC 10U M 10V
Q5103	405 092 1407	TR 2SA1577-R	C5106	403 340 1803	CERAMIC 1U M 25V
Q5104	405 115 6907	TR DTC114EE	C5108	403 327 0300	CERAMIC 10U Z 25V
Q5201	405 115 7201	TR DTC144EE	C5109	403 157 3601	CERAMIC 100P J 50V
Q5203	405 148 7100	TR CPH6401	C5201	403 338 4403	CERAMIC 0.1U K 16V
Q5208	405 092 1100	TR 2SA1577-P	C5202	403 338 4403	CERAMIC 0.1U K 16V
OR	405 092 1209	TR 2SA1577-Q	C5203	403 338 4403	CERAMIC 0.1U K 16V
OR	405 092 1407	TR 2SA1577-R	C5204	403 316 1400	CERAMIC 560P J 25V
Q5209	405 115 7201	TR DTC144EE	C5206	403 333 3708	CERAMIC 10U M 10V
		<b>(INTEGRATED CIRCUITS)</b>	C5207	403 113 3805	CERAMIC 1000P K 50V
IC171	409 452 4206	IC LV4127W	C5208	403 333 3708	CERAMIC 10U M 10V
IC174	409 423 6802	IC TK11245BM	C5210	403 333 3708	CERAMIC 10U M 10V
IC511	409 384 5807	IC MB3800PNF—G	C5211	403 332 9503	CERAMIC 1U M 6.3V
IC521	409 384 5807	IC MB3800PNF—G	C5212	403 333 3708	CERAMIC 10U M 10V
		<b>(DIODES)</b>	C5215	403 283 6309	CERAMIC 1U Z 10V
D1701	407 166 0606	DIODE MA365			<b>(RESISTORS)</b>
D5101	407 210 5403	DIODE RB551V-30	R1701	401 105 1600	MT-GLAZE 15K JA 1/16W
D5102	407 203 5601	DIODE RB461F	R1702	401 167 0702	MT-FILM 15K DU 1/16W
D5201	407 203 5601	DIODE RB461F	R1703	401 166 9409	MT-FILM 4.3K DU 1/16W
		<b>(OSCILLATOR)</b>	R1704	401 105 1600	MT-GLAZE 15K JA 1/16W
X1701	645 025 6004	OSC,CRYSTAL 3.579545MHZ,VPC-SX560 ONLY	R1705	401 105 0603	MT-GLAZE 10K JA 1/16W
X1701	645 030 0431	OSC,CRYSTAL 4.433619MHZ, EXCEPT VPC-SX560	R1706	401 167 1204	MT-FILM 27K DU 1/16W
		<b>(VARIABLE RESISTOR)</b>	R1707	401 167 1709	MT-FILM 47K DD 1/16W
VR171	645 028 2294	VR,SEMI,47K S	R1708	401 166 8105	MT-FILM 1K DU 1/16W
		<b>(INDUCTORS)</b>	R1709	401 037 5004	MT-GLAZE 0.000 ZA 1/10W
L1701	645 035 7183	INDUCTOR,10U J	R1710	401 105 7909	MT-GLAZE 0.000 ZA 1/16W
L1702	645 035 7183	INDUCTOR,10U J	R1711	401 105 0603	MT-GLAZE 10K JA 1/16W
L1703	645 020 1875	INDUCTOR,1500 OHM	R1712	401 105 0603	MT-GLAZE 10K JA 1/16W
L1704	645 020 1875	INDUCTOR,1500 OHM	R1713	401 105 0603	MT-GLAZE 10K JA 1/16W
L1707	645 020 1875	INDUCTOR,1500 OHM	R1714	401 166 9904	MT-FILM 6.8K DU 1/16W
L1708	645 020 1875	INDUCTOR,1500 OHM	R1715	401 167 1907	MT-FILM 56K DD 1/16W
L1709	645 020 1875	INDUCTOR,1500 OHM	R1718	401 148 6006	MT-GLAZE 2.2 JA 1/16W
L1710	645 036 5393	INDUCTOR,1000 OHM	R1720	401 105 5905	MT-GLAZE 560 JA 1/16W
L5101	645 035 9453	INDUCTOR,5.6U M	R1721	401 105 5905	MT-GLAZE 560 JA 1/16W
L5102	645 033 8762	INDUCTOR,47U K	R1722	401 105 5905	MT-GLAZE 560 JA 1/16W
L5201	645 035 9453	INDUCTOR,5.6U M	R1725	401 105 4205	MT-GLAZE 33K JA 1/16W
L5202	645 033 8663	INDUCTOR,10U K	R1726	401 105 0504	MT-GLAZE 1K JA 1/16W
		<b>(CAPACITORS)</b>	R1727	401 105 0603	MT-GLAZE 10K JA 1/16W
C1700	403 164 0204	CERAMIC 0.1U Z 25V	R1732	401 105 0603	MT-GLAZE 10K JA 1/16W
C1702	403 332 9503	CERAMIC 1U M 6.3V	R1761	401 105 7909	MT-GLAZE 0.000 ZA 1/16W
C1703	403 113 3805	CERAMIC 1000P K 50V	R1762	401 105 7909	MT-GLAZE 0.000 ZA 1/16W
C1705	403 139 7504	CERAMIC 39P J 50V	R1763	401 105 7909	MT-GLAZE 0.000 ZA 1/16W
C1706	403 157 4202	CERAMIC 220P J 50V	R1764	401 105 7909	MT-GLAZE 0.000 ZA 1/16W
C1707	403 155 1807	CERAMIC 0.01U K 25V	R1766	401 105 0603	MT-GLAZE 10K JA 1/16W
C1708	403 332 9503	CERAMIC 1U M 6.3V	R1767	401 167 1303	MT-FILM 30K DU 1/16W
C1709	403 157 7302	CERAMIC 6800P K 50V	R1768	401 166 3100	MT-FILM 22K DU 1/16W
C1710	403 332 9503	CERAMIC 1U M 6.3V	R1772	401 105 7909	MT-GLAZE 0.000 ZA 1/16W
C1711	403 283 6309	CERAMIC 1U Z 10V	R1775	401 166 8303	MT-FILM 1.2K DU 1/16W
C1712	403 332 9503	CERAMIC 1U M 6.3V	R5101	401 105 7909	MT-GLAZE 0.000 ZA 1/16W
C1714	403 155 1807	CERAMIC 0.01U K 25V	R5103	401 105 0702	MT-GLAZE 100K JA 1/16W
C1715	403 309 1301	CERAMIC 0.068U K 16V	R5104	401 105 5400	MT-GLAZE 47K JA 1/16W
C1717	403 333 3708	CERAMIC 10U M 10V	R5105	401 166 3308	MT-FILM 10 DC 1/16W
C1718	403 338 0405	CERAMIC 0.47U K 25V	R5106	401 105 7909	MT-GLAZE 0.000 ZA 1/16W
C1719	403 338 0405	CERAMIC 0.47U K 25V	R5107	401 166 5302	MT-FILM 68 DC 1/16W
C1720	403 338 0405	CERAMIC 0.47U K 25V	R5108	401 166 5708	MT-FILM 100 DU 1/16W
C1721	403 338 0405	CERAMIC 0.47U K 25V	R5144	401 166 9409	MT-FILM 4.3K DU 1/16W
C1722	403 283 6309	CERAMIC 1U Z 10V	R5200	401 037 5004	MT-GLAZE 0.000 ZA 1/10W
C1723	403 332 9503	CERAMIC 1U M 6.3V	R5201	401 105 1006	MT-GLAZE 1.2K JA 1/16W
C1724	403 113 3805	CERAMIC 1000P K 50V,VPC-SX560 ONLY	R5205	401 105 0504	MT-GLAZE 1K JA 1/16W
C1724	403 139 7306	CERAMIC 18P J 50V,EXCEPT VPC-SX560	R5206	401 167 1402	MT-FILM 33K DU 1/16W
C1726	403 207 0307	CERAMIC 1U Z 16V	R5207	401 166 3001	MT-FILM 2.7K DU 1/16W
C1727	403 332 9503	CERAMIC 1U M 6.3V	R5213	401 105 0702	MT-GLAZE 100K JA 1/16W
C1729	403 155 1807	CERAMIC 0.01U K 25V	R5214	401 105 2805	MT-GLAZE 2.2K JA 1/16W
C1730	403 164 0204	CERAMIC 0.1U Z 25V	R5215	401 105 7909	MT-GLAZE 0.000 ZA 1/16W
C1731	403 281 5205	CERAMIC 0.22U Z 16V	R5216	401 166 7306	MT-FILM 470 DU 1/16W
C1739	403 327 0300	CERAMIC 10U Z 25V	R5217	401 166 7108	MT-FILM 390 DU 1/16W
C1741	403 164 0006	CERAMIC 0.068U Z 25V	R5218	401 166 9409	MT-FILM 4.3K DU 1/16W
C1742	403 281 5205	CERAMIC 0.22U Z 16V			<b>(CONNECTORS)</b>
C1775	403 207 0307	CERAMIC 1U Z 16V	CN171	645 004 7183	SOCKET,FPC 24P (N.S.P)
C1776	403 332 9503	CERAMIC 1U M 6.3V	CN172	645 024 8184	PLUG,26P (N.S.P)
C1777	403 334 3806	CERAMIC 10U K 6.3V	CN173	645 009 9892	SOCKET,PWB-PWB 30(N.S.P)
C1778	403 332 8209	CERAMIC 10U M 16V	CN174	645 024 8184	PLUG,26P (N.S.P)
			CN175	645 027 7085	PLUG,8P (N.S.P)

LOCATION	PARTS NO.	DESCRIPTION
CN176	645 038 1843	PULG,4P (N.S.P)
CN512	645 005 6901	PLUG,SIDE-ZR-SM3 (N.S.P)
<b>(MISCELLANEOUS)</b>		
Y1702	636 055 2982	SPACER SHIELD CA3,SIDE-B
Y1703	636 058 2576	SHIELD TAPE
Y1704	636 058 2019	SHIELD TAPE

### COMPL PWB,PW-1

636 059 7709

#### (SEMICONDUCTORS)

Q5001	405 115 5207	TR 2SC4617 R
Q5002	405 148 3904	TR CPH3209
Q5003	405 092 1100	TR 2SA1577-P
OR	405 092 1209	TR 2SA1577-Q
OR	405 092 1407	TR 2SA1577-R
Q5004	405 092 1100	TR 2SA1577-P
OR	405 092 1209	TR 2SA1577-Q
OR	405 092 1407	TR 2SA1577-R
Q5005	405 092 1100	TR 2SA1577-P
OR	405 092 1209	TR 2SA1577-Q
OR	405 092 1407	TR 2SA1577-R
Q5006	405 148 7100	TR CPH6401
Q5007	405 148 3904	TR CPH3209
Q5008	405 150 5002	TR CPH3109
Q5009	405 148 7100	TR CPH6401
Q5010	405 115 5207	TR 2SC4617 R
Q5011	405 129 3008	TR UMD2N
Q5013	405 129 2902	TR UMH11N
Q5014	405 115 7201	TR DTC144EE
Q5018	405 148 6905	TR CPH3303
Q5020	405 148 6905	TR CPH3303
Q5021	405 129 2308	TR UMZ1N
Q5022	405 129 2704	TR UMH9N
Q5023	405 129 2308	TR UMZ1N
Q5024	405 129 2308	TR UMZ1N
Q5025	405 115 6907	TR DTC114EE
Q5026	405 129 2308	TR UMZ1N
Q5027	405 129 3008	TR UMD2N
Q5028	405 129 8409	TR UMC2N
Q5029	405 129 3008	TR UMD2N
Q5030	405 129 3008	TR UMD2N
Q5031	405 129 2308	TR UMZ1N
Q5032	405 129 3008	TR UMD2N
Q5401	405 115 7508	TR DTC123JE
Q5402	405 115 6907	TR DTC114EE
Q5405	405 150 6603	TR CPH3210
Q5406	405 150 5002	TR CPH3109
Q5407	405 115 5207	TR 2SC4617 R
Q5409	405 158 0306	TR CY25AAJ-8

#### (INTEGRATED CIRCUITS)

IC501	409 417 8300	IC LA5627W
IC502	409 466 6203	IC TK73200
IC504	409 301 5507	IC TC7S08FU

#### (DIODES)

D5001	407 203 5809	DIODE F02J9
D5002	407 203 5809	DIODE F02J9
D5003	407 201 2701	DIODE RB051L-40
D5004	407 201 2701	DIODE RB051L-40
D5005	407 149 0807	DIODE 1SS355
D5006	407 203 5809	DIODE F02J9
D5007	407 201 2701	DIODE RB051L-40
D5008	407 205 5203	DIODE RB521S-30
D5009	407 205 5203	DIODE RB521S-30
D5010	407 201 2701	DIODE RB051L-40
D5011	407 162 8507	DIODE DAN222
D5012	407 162 8507	DIODE DAN222
D5013	407 210 9401	DIODE RB491D
D5015	407 210 5403	DIODE RB551V-30
D5402	407 202 0300	DIODE F1F16
D5403	407 122 2606	DIODE SFPM-64
D5404	407 202 0102	DIODE F1SN4
D5405	407 199 4503	DIODE CR08AS-8-T1
D5407	407 162 8507	DIODE DAN222
D5410	407 162 8507	DIODE DAN222

#### (VARIABLE RESISTORS)

VR501	645 028 2249	VR,SEMI,3.3K S
-------	--------------	----------------

LOCATION	PARTS NO.	DESCRIPTION
VR503	645 028 2201	VR,SEMI,2.2K S
VR504	645 028 2201	VR,SEMI,2.2K S
VR505	645 028 2201	VR,SEMI,2.2K S
VR506	645 019 5143	VR,SEMI,1K S
VR507	645 019 5143	VR,SEMI,1K S
<b>(INDUCTORS)</b>		
L5001	645 036 5362	INDUCTOR,6.2U M
L5002	645 033 8762	INDUCTOR,47U K
L5003	645 033 8762	INDUCTOR,47U K
L5004	645 033 8762	INDUCTOR,47U K
L5006	645 021 5315	INDUCTOR,110 OHM
L5007	645 030 5887	INDUCTOR,1000 OHM
L5009	645 033 7918	INDUCTOR,10U M
L5010	645 036 5362	INDUCTOR,6.2U M
L5011	645 033 8663	INDUCTOR,10U K
L5012	645 033 8663	INDUCTOR,10U K
L5014	645 033 8663	INDUCTOR,10U K
L5015	645 033 8762	INDUCTOR,47U K
L5017	645 036 7496	INDUCTOR,4.7U M
L5018	645 033 8762	INDUCTOR,47U K
L5401	645 036 4938	INDUCTOR,10U M
<b>(TRANSFORMERS)</b>		
T5001	△ 645 040 0070	TRANS,POWER,PULSE
T5401	645 032 8831	TRANS,STEP UP
T5402	645 031 6951	TRANS,STEP UP
<b>(CAPACITORS)</b>		
C5001	403 325 7608	CERAMIC 1U K 16V
C5002	403 325 7608	CERAMIC 1U K 16V
C5003	403 323 6009	CERAMIC 10U M 16V
C5004	403 333 3708	CERAMIC 10U M 10V
C5009	403 335 1405	CERAMIC 10U K 6.3V
C5010	403 325 7608	CERAMIC 1U K 16V
C5011	403 323 6009	CERAMIC 10U M 16V
C5012	403 325 7608	CERAMIC 1U K 16V
C5013	403 325 7608	CERAMIC 1U K 16V
C5014	403 343 3101	CERAMIC 1U K 6.3V
C5015	403 335 1405	CERAMIC 10U K 6.3V
C5017	403 320 0604	CERAMIC 220P J 25V
C5018	403 335 1405	CERAMIC 10U K 6.3V
C5019	403 335 1405	CERAMIC 10U K 6.3V
C5022	403 335 1405	CERAMIC 10U K 6.3V
C5027	403 343 3101	CERAMIC 1U K 6.3V
C5028	403 320 0604	CERAMIC 220P J 25V
C5029	403 335 1405	CERAMIC 10U K 6.3V
C5031	403 343 3101	CERAMIC 1U K 6.3V
C5032	403 309 2407	CERAMIC 82P J 50V
C5033	403 279 5002	CERAMIC 4700P K 25V
C5034	403 276 1304	CERAMIC 1000P K 50V
C5038	403 283 5708	CERAMIC 2200P K 50V
C5039	403 320 0604	CERAMIC 220P J 25V
C5041	403 155 1807	CERAMIC 0.01U K 25V
C5042	403 155 1807	CERAMIC 0.01U K 25V
C5043	403 342 7506	CERAMIC 1000P J 50V
C5044	403 342 7506	CERAMIC 1000P J 50V
C5045	403 155 1807	CERAMIC 0.01U K 25V
C5046	403 343 3101	CERAMIC 1U K 6.3V
C5047	403 335 4703	CERAMIC 0.22U K 6.3V
C5048	403 155 1807	CERAMIC 0.01U K 25V
C5049	403 338 4403	CERAMIC 0.1U K 16V
C5050	403 155 2309	CERAMIC 4700P K 50V
C5051	403 275 3002	CERAMIC 0.047U K 16V
C5052	403 275 3002	CERAMIC 0.047U K 16V
C5053	403 169 2807	CERAMIC 330P J 50V
C5054	403 343 3101	CERAMIC 1U K 6.3V
C5055	403 343 3101	CERAMIC 1U K 6.3V
C5059	403 345 3000	POS-SOLID 47U M 6.3V
C5060	403 345 3000	POS-SOLID 47U M 6.3V
C5061	403 335 1405	CERAMIC 10U K 6.3V
C5062	403 345 3000	POS-SOLID 47U M 6.3V
C5063	403 338 2904	CERAMIC 0.47U K 10V
C5064	403 343 3101	CERAMIC 1U K 6.3V
C5069	403 345 3901	CERAMIC 3.3U M 6.3V
C5070	403 338 2904	CERAMIC 0.47U K 10V
C5071	403 345 3901	CERAMIC 3.3U M 6.3V
C5072	403 345 3000	POS-SOLID 47U M 6.3V
C5073	403 335 1405	CERAMIC 10U K 6.3V
C5074	403 338 4403	CERAMIC 0.1U K 16V
C5075	403 276 1304	CERAMIC 1000P K 50V



LOCATION	PARTS NO.	DESCRIPTION	LOCATION	PARTS NO.	DESCRIPTION
IC302	409 383 1008	S-8423NFS	R3006	401 105 5400	MT-GLAZE 47K JA 1/16W
IC303	410 298 3605	IC S-8324A50MC-EPE	R3007	401 105 0603	MT-GLAZE 10K JA 1/16W
IC311	409 407 0505	IC TK11331BM	R3010	401 105 5400	MT-GLAZE 47K JA 1/16W
IC312	409 432 2505	IC LMV321M7X	R3011	401 167 2508	MT-FILM 100K DD 1/16W
IC313	409 432 2505	IC LMV321M7X	R3012	401 167 2508	MT-FILM 100K DD 1/16W
IC314	409 446 7305	IC TPA301D-SOL008-P-0150	R3014	401 105 0702	MT-GLAZE 100K JA 1/16W
IC315	409 432 2505	IC LMV321M7X	R3015	401 105 5400	MT-GLAZE 47K JA 1/16W
IC316	409 301 5309	IC TC7S32FU	R3016	401 105 0603	MT-GLAZE 10K JA 1/16W
	<b>(DIODES)</b>		R3017	401 105 0702	MT-GLAZE 100K JA 1/16W
D3024	407 162 8507	DIODE DAN222	R3018	401 105 0504	MT-GLAZE 1K JA 1/16W
D3041	407 199 1809	LED SML-020MLT, VF LED	R3021	401 105 4205	MT-GLAZE 33K JA 1/16W
D3042	407 187 6304	LED SML-110VT, SELF TIMER LED	R3022	401 105 4205	MT-GLAZE 33K JA 1/16W
D3051	407 149 0807	DIODE 1SS355	R3023	401 105 4205	MT-GLAZE 33K JA 1/16W
D3061	407 210 5403	DIODE RB551V-30	R3024	401 105 4205	MT-GLAZE 33K JA 1/16W
D3062	407 188 9809	DIODE MA742	R3025	401 105 4205	MT-GLAZE 33K JA 1/16W
D3063	407 179 1805	DIODE DAP222	R3026	401 105 4205	MT-GLAZE 33K JA 1/16W
D3064	407 179 1805	DIODE DAP222	R3041	401 105 5202	MT-GLAZE 470 JA 1/16W
D3065	407 179 1805	DIODE DAP222	R3042	401 105 2706	MT-GLAZE 220 JA 1/16W
D3066	407 179 1805	DIODE DAP222	R3043	401 105 5202	MT-GLAZE 470 JA 1/16W
D3067	407 179 1805	DIODE DAP222	R3051	401 105 0702	MT-GLAZE 100K JA 1/16W
D3068	407 179 1805	DIODE DAP222	R3052	401 105 0702	MT-GLAZE 100K JA 1/16W
D3069	407 149 0807	DIODE 1SS355	R3053	401 105 0504	MT-GLAZE 1K JA 1/16W
D3070	407 149 0807	DIODE 1SS355	R3056	401 105 0504	MT-GLAZE 1K JA 1/16W
D3073	407 149 0807	DIODE 1SS355	R3101	401 105 7909	MT-GLAZE 0.000 ZA 1/16W
	<b>(OSCILLATORS)</b>		R3102	401 105 2805	MT-GLAZE 2.2K JA 1/16W
X3001	645 034 8006	OSC,CERAMIC 4.00MHZ	R3103	401 105 0603	MT-GLAZE 10K JA 1/16W
X3002	645 034 7993	OSC,CRYSTAL 32.768KHZ	R3104	401 105 0405	MT-GLAZE 100 JA 1/16W
	<b>(INDUCTOR)</b>		R3105	401 105 5301	MT-GLAZE 4.7K JA 1/16W
L3061	645 010 0987	INDUCTOR,100U K	R3106	401 105 0504	MT-GLAZE 1K JA 1/16W
	<b>(CAPACITORS)</b>		R3107	401 105 3406	MT-GLAZE 27K JA 1/16W
C3001	403 145 9905	CERAMIC 22P J 50V	R3108	401 105 2805	MT-GLAZE 2.2K JA 1/16W
C3002	403 145 9905	CERAMIC 22P J 50V	R3109	401 105 0702	MT-GLAZE 100K JA 1/16W
C3003	403 338 4403	CERAMIC 0.1U K 16V	R3120	401 105 0504	MT-GLAZE 1K JA 1/16W
C3004	403 113 3805	CERAMIC 1000P K 50V	R3121	401 105 7909	MT-GLAZE 0.000 ZA 1/16W
C3005	403 155 1807	CERAMIC 0.01U K 25V	R3122	401 105 7909	MT-GLAZE 0.000 ZA 1/16W
C3006	403 338 4403	CERAMIC 0.1U K 16V	R3123	401 105 7909	MT-GLAZE 0.000 ZA 1/16W
C3008	403 316 1400	CERAMIC 560P J 25V	R3136	401 105 4304	MT-GLAZE 330K JA 1/16W
C3009	403 338 4403	CERAMIC 0.1U K 16V	R3137	401 105 4106	MT-GALZE 3.3K JA 1/16W
C3051	403 274 0903	TA-SOLID 22U M 6.3V	R3138	401 105 4304	MT-GLAZE 330K JA 1/16W
C3053	403 338 4403	CERAMIC 0.1U K 16V	R3139	401 105 4106	MT-GALZE 3.3K JA 1/16W
C3054	403 332 9503	CERAMIC 1U M 6.3V	R3141	401 105 7909	MT-GLAZE 0.000 ZA 1/16W
C3055	403 338 4403	CERAMIC 0.1U K 16V	R3142	401 105 1006	MT-GLAZE 1.2K JA 1/16W
C3056	403 338 4403	CERAMIC 0.1U K 16V	R3143	401 105 7909	MT-GLAZE 0.000 ZA 1/16W
C3057	403 324 3502	DL-ELECT 0.1F Z 5.5V	R3144	401 105 0603	MT-GLAZE 10K JA 1/16W
C3058	403 332 9503	CERAMIC 1U M 6.3V	R3145	401 105 0603	MT-GLAZE 10K JA 1/16W
C3061	403 322 3504	CERAMIC 22U Z 10V	R3146	401 105 7909	MT-GLAZE 0.000 ZA 1/16W
C3062	403 332 8209	CERAMIC 10U M 16V	R3147	401 105 7909	MT-GLAZE 0.000 ZA 1/16W
C3101	403 073 4409	CERAMIC 0.039U K 50V	R3149	401 105 2102	MT-GLAZE 18K JA 1/16W
C3102	403 334 3806	CERAMIC 10U K 6.3V	R3150	401 105 1105	MT-GLAZE 12K JA 1/16W
C3103	403 155 1807	CERAMIC 0.01U K 25V	R3151	401 105 7909	MT-GLAZE 0.000 ZA 1/16W
C3104	403 155 1807	CERAMIC 0.01U K 25V	R3152	401 105 0702	MT-GLAZE 100K JA 1/16W
C3105	403 073 1200	CERAMIC 0.033U K 50V	R3153	401 105 6605	MT-GLAZE 6.8K JA 1/16W
C3106	403 332 9503	CERAMIC 1U M 6.3V	R3154	401 113 6208	MT-GLAZE 3.6K JA 1/16W
C3107	403 338 4403	CERAMIC 0.1U K 16V	R3155	401 105 1105	MT-GLAZE 12K JA 1/16W
C3108	403 155 1807	CERAMIC 0.01U K 25V	R3157	401 105 5400	MT-GLAZE 47K JA 1/16W
C3109	403 332 9503	CERAMIC 1U M 6.3V	R3161	401 105 4809	MT-GLAZE 390K JA 1/16W
C3111	403 281 2402	CERAMIC 0.22U K 16V	R3162	401 105 0603	MT-GLAZE 10K JA 1/16W
C3112	403 332 9503	CERAMIC 1U M 6.3V	R3163	401 105 7909	MT-GLAZE 0.000 ZA 1/16W
C3113	403 332 9503	CERAMIC 1U M 6.3V	R3164	401 113 6703	MT-GLAZE 9.1K JA 1/16W
C3115	403 281 5007	CERAMIC 0.033U K 25V	R3166	401 105 2003	MT-GLAZE 1.8K JA 1/16W
C3116	403 332 9503	CERAMIC 1U M 6.3V	R3167	401 105 1006	MT-GLAZE 1.2K JA 1/16W
C3118	403 332 9503	CERAMIC 1U M 6.3V	R3168	401 105 4304	MT-GLAZE 330K JA 1/16W
C3119	403 332 9503	CERAMIC 1U M 6.3V	R3170	401 105 5202	MT-GLAZE 470 JA 1/16W
C3120	403 332 9503	CERAMIC 1U M 6.3V	R3171	401 105 4304	MT-GLAZE 330K JA 1/16W
C3121	403 334 3806	CERAMIC 10U K 6.3V		<b>(SWITCHES)</b>	
C3122	403 281 5007	CERAMIC 0.033U K 25V	S3001	645 029 5911	SWITCH,SLIDE 1P-3T,
C3123	403 332 9503	CERAMIC 1U M 6.3V	S3002	645 035 6599	SWITCH,PUSH, INFO
C3124	403 332 9503	CERAMIC 1U M 6.3V		<b>(CONNECTORS)</b>	
C3125	403 332 9503	CERAMIC 1U M 6.3V	CN301	645 035 5424	SOCKET,PWB-PWB 30(N.S.P)
C3127	403 332 9503	CERAMIC 1U M 6.3V	CN302	645 037 7778	PLUG,2P (N.S.P)
C3128	403 332 9503	CERAMIC 1U M 6.3V	CN303	645 035 8425	SOCKET,FPC 16P (N.S.P)
C3129	403 332 9503	CERAMIC 1U M 6.3V	CN310	645 002 2876	PLUG,2P (N.S.P)
	<b>(RESISTORS)</b>				
R3001	401 105 4106	MT-GALZE 3.3K JA 1/16W			
R3002	401 105 5400	MT-GLAZE 47K JA 1/16W			
R3003	401 105 0603	MT-GLAZE 10K JA 1/16W			
R3004	401 105 4304	MT-GLAZE 330K JA 1/16W			
R3005	401 105 5400	MT-GLAZE 47K JA 1/16W			

LOCATION	PARTS NO.	DESCRIPTION
----------	-----------	-------------

## ACCESSORIES

	△ 645 043 5492	BATTERY CHARGER,VPC-SX560E ONLY
	△ 645 044 8249	BATTERY CHARGER,EXCEPT VPC-SX560E
	△ 645 037 0205	BATTERY,RECHARGE,COMP. (1.2V,NI-MH)
	△ 645 036 4129	CORD,POWER-1.2MK,VPC-SX560EX ONLY
	△ 645 036 7434	CORD,POWER-1.2MK,VPC-SX560E ONLY
	△ 645 036 9896	CORD,POWER-1.8MK,VPC-SX560 ONLY
	645 028 8944	CABLE,DSC A/V [(1) AV cable]
	645 028 8951	CABLE,DSC A/V [(1) AV cable]
	645 028 8920	CABLE,DSC DOS/V
	645 028 8937	[(2) Computer serial port interface cable]
	645 017 7200	CABLE,MINI 8P&D-SUB 9P,EXCEPT VPC-SX560E[(3) Adapter for Macintosh computer]
	645 020 3718	CABLE,MINI 8P&D-SUB 9P,EXCEPT VPC-SX560E[(3) Adapter for Macintosh computer]
	645 020 3725	CABLE,MINI 8P&D-SUB 9P,EXCEPT VPC-SX560E[(3) Adapter for Macintosh computer]
	645 020 7129	CABLE,MINI 8P&D-SUB 9P,EXCEPT VPC-SX560E[(3) Adapter for Macintosh computer]
	645 040 2807	CABLE,DSC USB [(4) USB interface cable]
	636 057 8968	CASE SOFT-SX113/J
	636 056 1007	STRAP HAND-SR662/J
	645 037 2322	CARD,CF (CompactFlash),EXCEPT VPC-SX560E
	645 037 2339	CARD,CF (CompactFlash),EXCEPT VPC-SX560E
	645 043 5553	DISC,CD-ROM CEL SUSP52 E
	645 043 5546	[Sanyo Software Pack 5.2]
9112	645 043 5546	DISC,CD-ROM MGI [MGI PhotoSuite 3]
	636 060 0270	INSTRUCTION MANUAL [CAMERA] (English, French, Spanish)
9113	636 060 0287	INSTRUCTION MANUAL [Sanyo Software Pack 5.2] (English)
9114	636 059 1073	INSTRUCTION MANUAL PDF (English, French, German, Spanish)
9115	636 060 0294	INSTRUCTION MANUAL [MGI PhotoSuite 3] (English, French, German, Spanish)
9118	636 060 0300	INSTRUCTION MANUAL [CAMERA] (German),EXCEPT VPC-SX560

## PACKING MATERIALS

	636 060 4353	CARTON CASE INNER-SX114/E, VPC-SX560E ONLY
	636 059 8706	CARTON CASE INNER-SX114/U, VPC-SX560 ONLY
	636 059 8690	CARTON CASE INNER-SX114EX, VPC-SX560EX ONLY
	636 060 6036	CUSHION SHEET-SX354/JO
	636 060 4377	REINFORCEMENT PAD,A-114EX (BOTTOM)
	636 060 4384	REINFORCEMENT PAD,B-114EX (TOP)



SANYO Electric Co.,Ltd.  
Osaka, Japan





## Free Manuals Download Website

<http://myh66.com>

<http://usermanuals.us>

<http://www.somanuals.com>

<http://www.4manuals.cc>

<http://www.manual-lib.com>

<http://www.404manual.com>

<http://www.luxmanual.com>

<http://aubethermostatmanual.com>

Golf course search by state

<http://golfingnear.com>

Email search by domain

<http://emailbydomain.com>

Auto manuals search

<http://auto.somanuals.com>

TV manuals search

<http://tv.somanuals.com>