

# SCAG®

## HYDROSTATIC DRIVE COMMERCIAL MOWERS TECHNICAL MANUAL

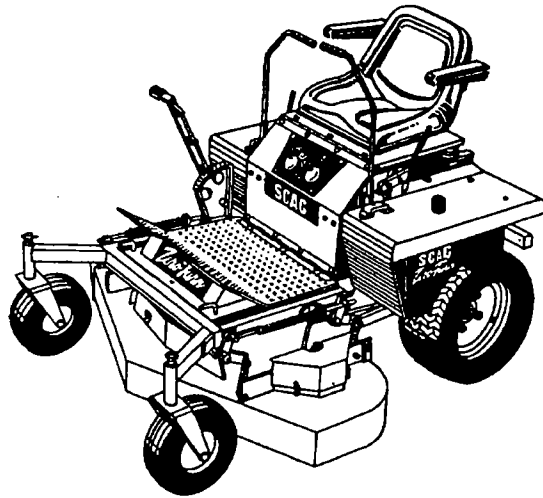

### MODELS

STZ-20KH

SMTZ-61

© 1993  
SCAG POWER EQUIPMENT  
DIVISION OF METALCRAFT OF MAYVILLE, INC.

PART NO. 01157  
PRINTED 04/93  
PRINTED IN USA

**TABLE OF CONTENTS**

<b>SUBJECT</b>	<b>PAGE</b>
<b>Safety Instructions</b> -----	<b>2-3</b>
<b>Hydraulic Safety</b> -----	<b>3</b>
<b>Setup Instructions</b> -----	<b>4-6</b>
<b>Adjustments</b> -----	<b>7-9</b>
Neutral Adjustment -----	7
Straight Line Running -----	7
Over-Center Spacing -----	8
Cutter Deck Drive Belt -----	8
Blade Drive Belt -----	8
Tire Pressures -----	8
Parking Brake -----	8
<b>Initial Run, Inspection, &amp; Operating Instructions</b> -----	<b>9</b>
<b>Maintenance</b> -----	<b>9</b>
<b>Lubrication &amp; Maintenance Chart</b> -----	<b>10</b>
<b>Illustrated Parts Listings</b> -----	<b>11-24</b>
SMZ-61 Cutter Deck -----	11-12
Cutter Deck Controls -----	13-14
Sheet Metal Components -----	15-16
Hydraulic Components -----	17-18
Traction Drive Components -----	19-20
Brake and Steering Controls -----	21-22
Instrument Panel and Electrical Components -----	23-24
<b>Electrical Diagram</b> -----	<b>25</b>
<b>Replacement Decals</b> -----	<b>26</b>
<b>Warranty</b> -----	<b>27</b>

Your mower was built to the highest standards in the industry. However, your mower is only as safe as the operator. Carelessness or error on the part of the operator may result in serious bodily injury. Hazard control and accident prevention are dependent upon the awareness, concern, prudence, and proper training of the personnel involved in the operation, transport, maintenance, and storage of the equipment. Make sure every operator is properly trained and thoroughly familiar with all of the controls and safety instructions before operating the equipment.

## **SAFETY INSTRUCTIONS**

### **⚠ WARNING**

**Do not operate on steep slopes. Riding lawn-mowers can tip over when used on an excessive slope. To check a slope, attempt to back up (with cutter deck down). If unit can not back up the slope without the wheels slipping then stay off the slope. If you are in doubt about hillside operation, stay off the slope.**

**Always back up when loading machine on ramps or tilt bed trailers.**

1. Know the controls and how to stop quickly. READ THIS TECHNICAL MANUAL and instructions furnished with attachments. A replacement manual is available by sending complete model and serial number to:  
SCAG Power Equipment, Inc.  
1000 Metalcraft Drive  
Mayville, WI 53050
2. Do not allow children to operate the machine. Do not allow adults to operate it without proper instruction.
3. Do not carry passengers. Do not mow when children and others are around.
4. Clear the work area of objects (wires, rocks, etc.) that might be picked up and thrown.
5. Disengage all attachment clutches and engage parking brake before attempting to start the engine.
6. Disengage power to attachments and engage parking brake before leaving the operator's position.
7. Disengage power to attachments, stop the engine and remove key before making any repairs or adjustments.
8. Disengage power to attachments when transporting or not in use.
9. Take all possible precautions when leaving the vehicle unattended, such as disengaging power to attachments, lowering the attachments, setting the parking brake, stopping the engine, and removing the key.
10. Do not stop or start suddenly when going uphill or downhill. Mow up and down the face of steep slopes; never across the face.
11. Reduce speed and exercise extreme caution on slopes and in sharp turns to prevent tipping or loss of control. Be especially cautious when changing direction on slopes. If necessary to turn on a hill, always turn downhill.
12. Stay alert for holes, rocks, and roots in the terrain and other hidden hazards. Keep away from drop-offs.
13. Use care when pulling loads or using heavy equipment.
  - a. Use only approved drawbar hitch points.
  - b. Limit loads to those you can safely control.
  - c. Do not turn sharply. Use care when backing.
  - d. Use counterweights or wheel weights when suggested in this technical manual.
14. Watch out for traffic when crossing or near roadways.
15. When using any attachments, never direct discharge of material toward bystanders nor allow anyone near the mower while in operation.
16. Handle gasoline with care - it is highly flammable.
  - a. Use approved gasoline container.
  - b. Never remove the fuel cap of, or add gasoline to, a running or hot engine or an engine that has not been allowed to cool for several minutes after running. Never fill the tank indoors and always clean up spilled gas.
  - c. Do not run the engine indoors.

## SAFETY INSTRUCTIONS CONT'D

---

17. Keep the mower and attachments in good operating condition, and keep safety devices and shields in place and in working condition.
18. Keep all nuts, bolts, and screws tight to be sure the equipment is in safe working condition.
19. Never store the mower with gasoline in the tank inside a building where fumes may reach an open flame or spark. Allow the engine to cool before storing in any enclosure.
20. To reduce fire hazard, keep the engine free of grass, leaves or excessive lubricants.
21. The mower and attachments should be stopped and inspected for damage after striking a foreign object, and the damage should be repaired before restarting and operating the equipment.
22. Do not change the engine governor settings or overspeed the engine.
23. When using the machine with mower, proceed as follows:
  - a. Mow only in daylight or in good artificial light.
  - b. Never make a cutting height adjustment while the engine is running if the operator must dismount to do so.
  - c. Shut all engines off and remove key when removing the grass catcher or unclogging chute.
  - d. Check the blade mounting bolts for proper tightness at frequent intervals.
24. Under normal usage, the grass catcher bag material is subject to deterioration and wear. Check bag frequently for deterioration and wear and replace worn bags. Check that replacement bags comply with the original manufacturer's recommendations or specifications.
25. Disengage power to mower before backing up. Do not mow in reverse unless absolutely necessary and then only after observation of the entire area behind the mower.
26. The discharge chute must be installed and in the down position on the side discharge mower, except when optional grass catcher or mulching plate is completely installed. If the mower discharge chute plugs, shut engine off and wait for all movement to stop before removing obstruction.
27. Perform only those maintenance instructions described in this manual. If major repairs are needed or assistance is desired, contact an Authorized Scag Servicing Dealer. To ensure optimum performance and safety, always purchase genuine SCAG replacement parts and accessories. NEVER USE "WILL FIT" replacement parts and accessories made by another manufacturer. Use of unapproved replacement parts may void the warranty.

## HYDRAULIC SAFETY

---

- Safely relieve all pressure in the system before disconnecting the lines or performing work on the system.
- Keep body and hands away from pin holes or nozzles that eject hydraulic fluid under high pressure. Use paper or cardboard and not hands to search for leaks.
- Hydraulic fluid escaping under high pressure may have sufficient force to penetrate skin and cause serious injury. If foreign fluid is injected into the the skin, it must be surgically removed within a few hours by a doctor familiar with this form of injury or gangrene may result.
- Make sure all hydraulic fluid connections are tight and all hydraulic hoses and lines are in good condition before applying pressure to the system.

## SETUP INSTRUCTIONS

1. Remove all crating and packing materials. Lay out loose mounting hardware according to the "Where Used" as listed in the loose parts packing list.

**⚠ WARNING:** Severe chemical burns can result from improper handling of battery electrolyte. Use proper eye, skin and clothing protection to prevent contact with eyes, skin and clothing.

External contact: Flush with water.  
 Internal contact: Drink large quantities of water, followed with milk of magnesia, beaten egg or vegetable oil. **CALL A PHYSICIAN IMMEDIATELY!**  
**IMPORTANT - In case of internal contact DO NOT give fluids that would induce vomiting.**

Eye contact: Flush with water for at least 15 minutes and get medical attention immediately!

**⚠ WARNING:** Explosive gases are vented from a battery when being charged or discharged which could explode if exposed to a flame or spark.

2. Remove battery from the unit. Fill with electrolyte solution. Charge at 3 to 5 amps for about 2 hours. Check fluid level and add electrolyte until level is up to the bottom of the split ring.

**NOTE:** Future need to adjust fluid level requires distilled water.

Wash and dry off battery. Coat terminals with grease to minimize corrosion.

3. Mount drive tires using lug nuts located on the hubs. Make certain that the air valve is facing outward and the tapered end of the lug nuts are contacting the rim.

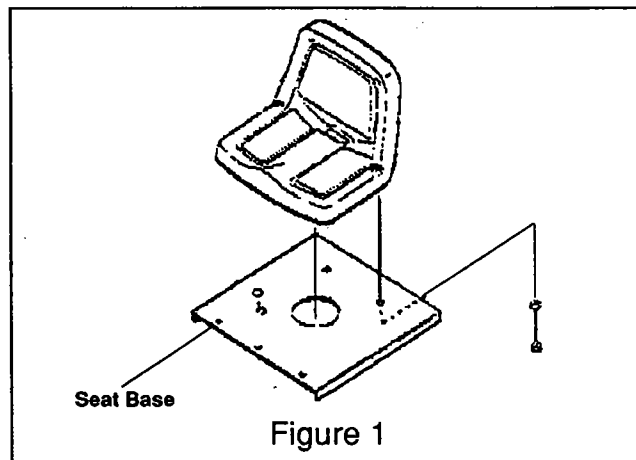

4. Attach the seat assembly to the seat base using four 5/16-18 x 3/4" bolts and 5/16" lock washers.
5. Mount RH and LH hand control handles to the control lever bars and secure using the four 3/8-16 x 1" bolts, 3/8" lockwashers and 3/8" flatwashers. The hand control handles have slotted holes to adjust for the operators comfort.

**⚠ WARNING:** Do not operate machine without cutter deck properly mounted.

6. Check that cutter deck push arms are set for the same distance. There should be approximately 15 1/8" from center of arm to center of ball joint (See figure 2). Both **must** be the same distance.
7. Roll cutter deck underneath the cutter deck mounting frame.

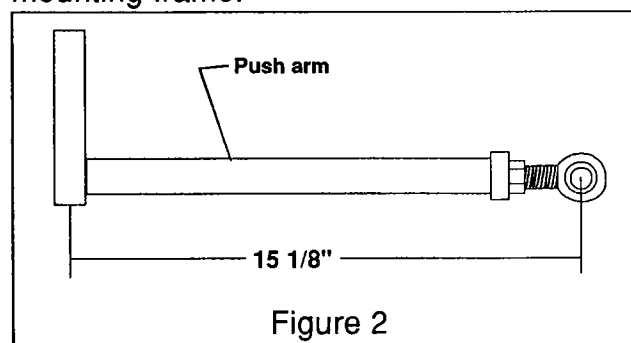

## SETUP INSTRUCTIONS CONTINUED

8. Remove the shaft from the deck and attach push arms to cutter deck by lining up the holes and sliding the shaft through the arm (See figure 3). Secure with 5/16-18 x 1" hex head bolt, 5/16" lockwasher, and 5/16-18 hex nut.

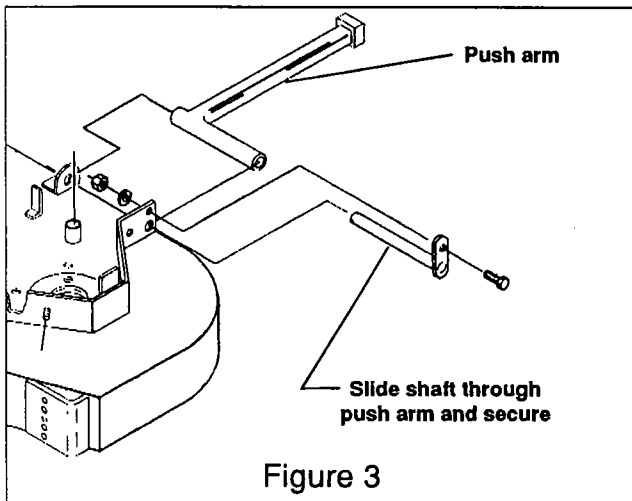

9. Mount cutter deck to the four chains, leaving the left front corner nuts loose on the slot.
10. Turn the nut on cutter deck adjustment stud until it bottoms out (See figure 4). When the nut bottoms out on the adjustment stud, tighten to approximately 30 ft. lbs. Do the same for both sides.

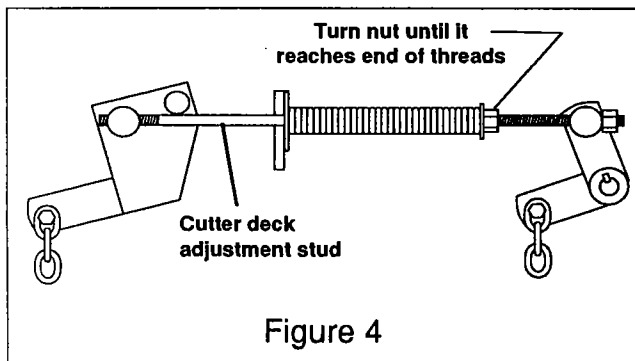

11. Before going on to the next step, check that tire pressures are correct. The drive tires should be at 12-14 psi and caster tires should be at 25 psi. Each set of tires should be set equal.

12. Put cutter deck height lever into one of the middle holes in the height control bracket.
13. With unit parked on a flat level surface, go to the discharge side of cutter deck and measure the distance from the rear bottom edge of the cutter deck to the ground.
14. On the same side of the cutter deck, measure the distance from the front bottom edge of the cutter deck to the ground. The front edge of the cutter deck should be 1/4" lower than the rear. To make this adjustment, loosen the jam nut and turn the spring compression nut. Turning this nut should rotate the adjustment stud. Rotate in either direction until front of deck is adjusted. Retighten jam nut. (See figure 5).

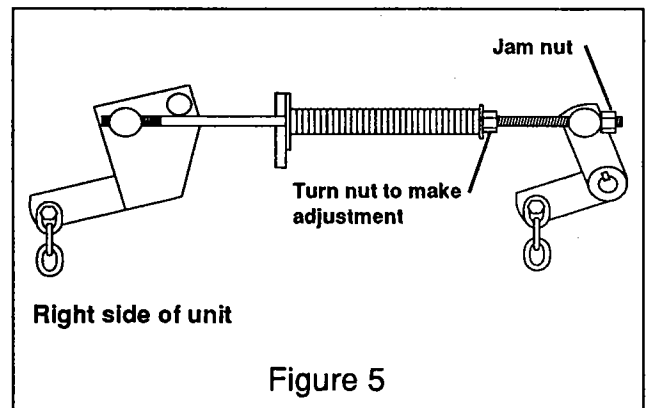

15. On the trim side of the cutter deck, raise deck by lifting or jacking up until the deck is level with other side. Tighten serrated flange nut to hold bolt in the slot. (See figure 6) Remove jack.

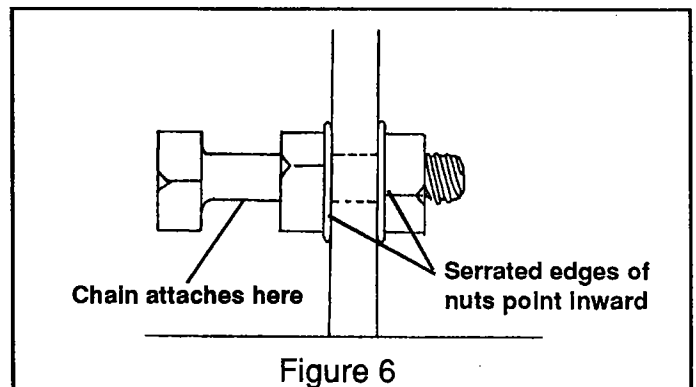

## SETUP INSTRUCTIONS CONTINUED

16. On the trim side of the cutter deck, adjust rear of deck by turning nut on adjustment rod. (See figure 7) Rear of deck should be 1/4" higher than front of deck. At this point all four chains should be tight.

17. Route the blade drive belt around the engine pulley and the cutter deck pulleys. The belt guard must be removed and reinstalled to route the belt around engine pulley.

18. Install the mower engagement control rod to the bellcrank located by the left drive tire and then connect to the over-center mechanism on the cutter deck. Secure with hair pins. The long end of the rod connects to the cutter deck. The flat washer on both ends of the rod goes next to the cotter pins.

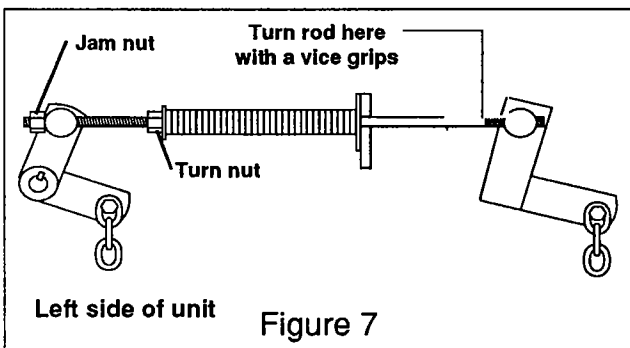

19. Push the mower engagement lever forward until the over-center mechanism snaps into place. Check the over-center spacing (See figure 8).

20. Place cutter deck in the cutting height that will be used when cutting grass. With the machine on a flat surface, relocate anti-scalp wheels to the lowest position possible without making contact with the ground.

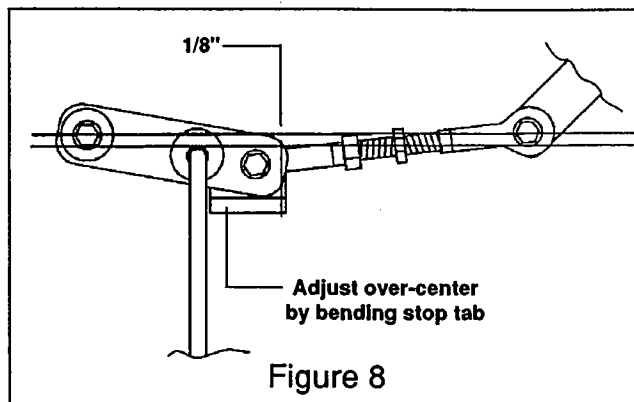

21. Attach the discharge chute to the cutter deck using two 5/16-18 x 1" bolts and elastic stop nuts. Tighten only enough to remove excessive end play. Discharge chute must be free to move up and down.

22. Install battery into the battery support, connect the positive cable to the positive terminal and cover with the boot, then attach the negative cable. Install battery cover.

**Note:** Unit was shipped without oil in the hydrostatic oil reservoir or the engine.

23. Refer to the engine manual for the recommended type of oil to be added to the engine.

24. Fill hydrostatic oil reservoir with SAE 10W30 to the line on dipstick. DO NOT OVER FILL!

25. Check machine to make sure all bolts are properly tightened.

26. Fill fuel tank with gasoline.

27. Open shut-off valve under tank.

## ADJUSTMENTS

### Neutral Adjustment

1. Elevate the frame on jack stands so the drive wheels are free to rotate. Block caster wheels to prevent an accident should the unit fall off the jack stands. Close dump valves on pump.

**NOTE:** Please refer to instructions on filling oil reservoir and engine with oil. (See page 6)

2. Start engine and determine if the drive wheels rotate.

**NOTE:** If hydraulic components (pumps, motors, hoses, etc.) are replaced, all air **must** be bled from system prior to going to step 3.

To bleed the system at this point, run machine at about 2000 rpm for about 15 seconds at full forward and about 15 seconds at full reverse.

3. Adjust each drive wheel separately by using the turnbuckles located under the operator seat and beside each of the pumps.
4. Loosen jam nut on turnbuckle (See figure 9).
5. If drive wheel is rotating forward, adjust the turnbuckle clockwise. If drive wheel is rotating rearward, adjust the turnbuckle counterclockwise. Adjust until the drive wheel stops rotating (See figure 10).
6. Tighten jam nut to secure neutral position (See figure 10).

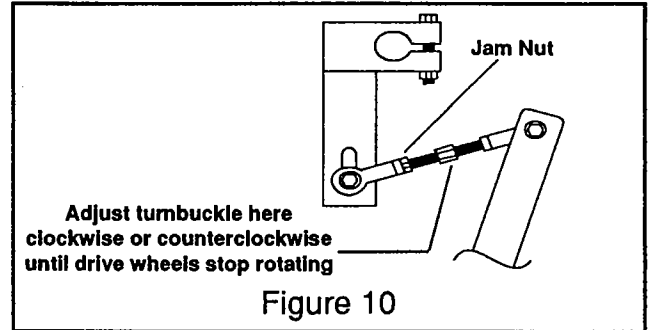
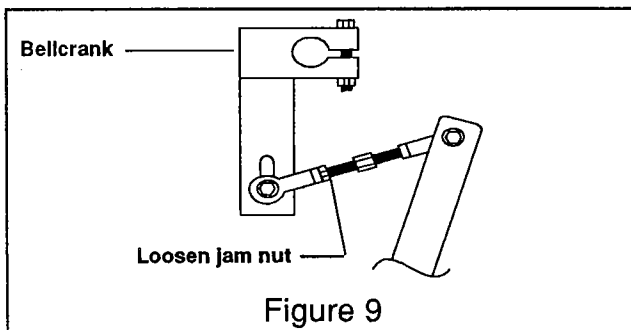

7. Adjust other drive wheel if necessary.
8. Actuate hand control levers forward and reverse. Allow levers to self center and check that neutral is maintained.
9. The neutral return mechanisms located on the fender are adjusted at the factory and should not need to be readjusted.

### Straight Line Running Adjustment

1. First check for equal drive wheel tire pressure. **NOTE:** The right side pump has a fixed speed and cannot be adjusted, so this adjustment must be done on the left side pump.
2. Locate turnbuckle for left side pump under the operator seat and above the left side pump.
3. Loosen nut securing turnbuckle to bellcrank (See figure 11).
4. Adjust position of turnbuckle by moving it in the mounting slot either up to slow down left wheel or down to speed up left wheel. Secure turnbuckle by tightening nut.
5. Readjust neutral if necessary.

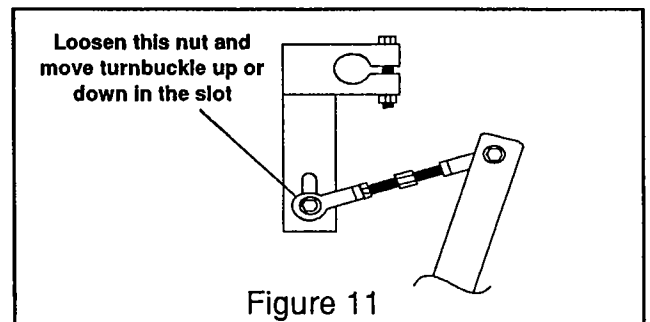



## ADJUSTMENTS CONT'D

### Over-Center Spacing

Engage blade clutch lever to snap over-center mechanism into place. There should be 3/8" between clutch rod and a straight edge. Bend the stop tab to adjust clearance.

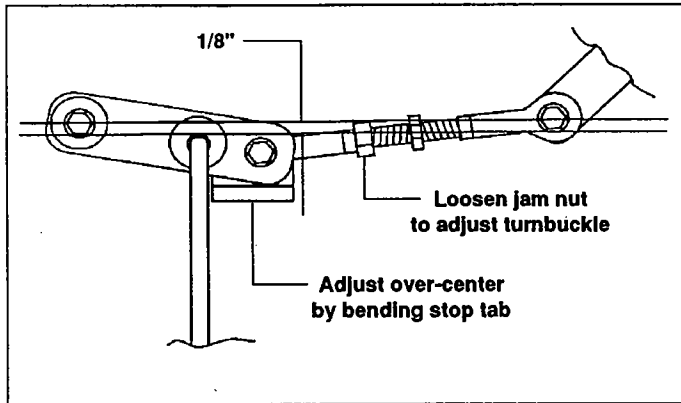

### Cutter Deck Drive Belt

Belt tension should not be adjusted until over-center spacing is checked. Adjust the belt tension so that the belt moves 1/2" with 10 pounds of pressure. Adjustment is made by loosening the jam nut and lengthening or shortening the turnbuckle.

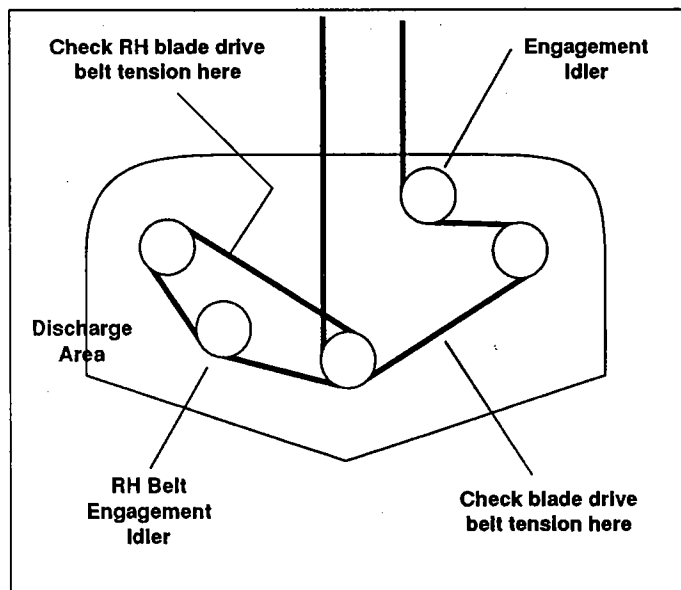

### Right Hand Blade Drive Belt

Adjust the belt tension so that the belt moves 1/2" with 10 lbs. of pressure. Adjust tension by tightening or loosening the "J"-bolt.

### Tire Pressures

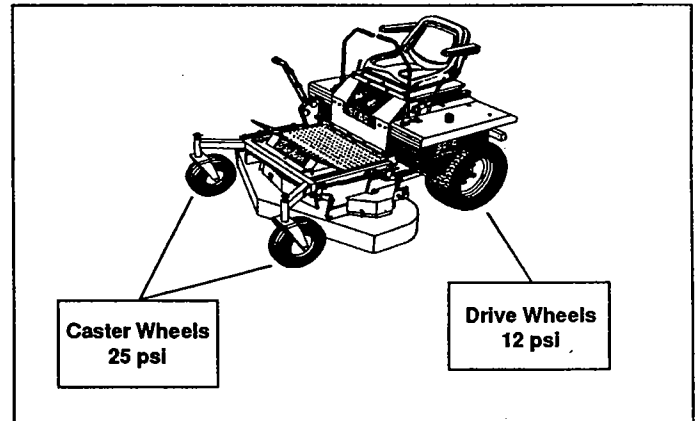

### Parking Brake

With parking brake in the off position, turn the handle clockwise to tighten the brakes or turn the handle counter clockwise to loosen the brakes. The brakes should be adjusted so that the drive wheels lock rather than roll when the brake is on.

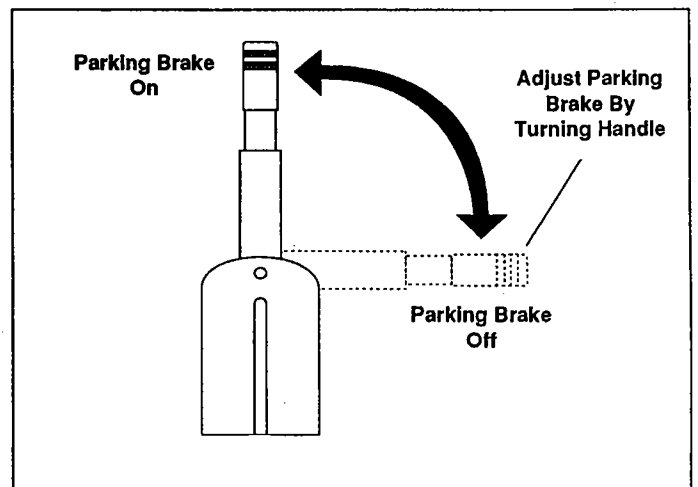

## INITIAL RUN, INSPECTION AND OPERATING INSTRUCTIONS

1. Check for correct routing of belts and for correct clearance of belt guides.
2. Check for correct alignment and initial tension of cutter blade drive belts.
3. Check that all fasteners are correctly tightened.
4. Add oil to engine and hydrostatic oil reservoir. Mower was shipped without oil. Refer to page 6 for instructions on filling engine and oil reservoir with oil.
5. Fill fuel tank with clean, fresh lead free gasoline.
6. To start engine:  
Place control handles in neutral lock position.  
Pull mower engagement lever to off position.  
Put parking brake in engaged position.  
Adjust throttle and choke as required.  
Turn ignition key to start.
7. Release the parking brake. Push mower engagement lever forward until over-center snaps into the engaged position. Allow belts to run for 5 minutes.
8. Release the parking brake. Observe to see that the unit does not creep forward or backwards. If it does creep, adjust hydro neutral control as specified in adjustment section.
9. Operate the unit forward and backward. Check that all systems function correctly.
10. Shut off engine and recheck cutter deck drive belts for proper tension, and any signs of rubbing. Correct and adjust as necessary.

## MAINTENANCE

### Cutter Blades

**CAUTION:** Sharp blade can cut fingers or hand. Always wear heavy-duty gloves when working with blades.

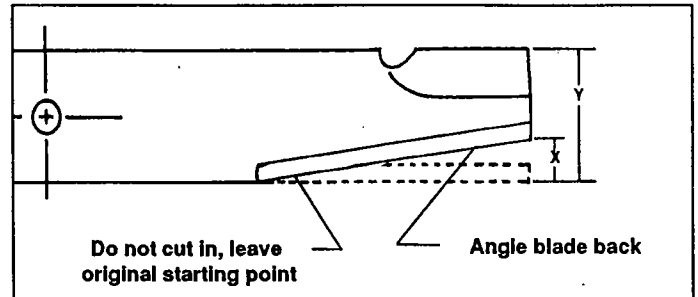

**Do not** sharpen X beyond 1/3 of the width Y of the blade. Suggestion: Dress the blade with a file. Using a wheel grinder may burn the blade.

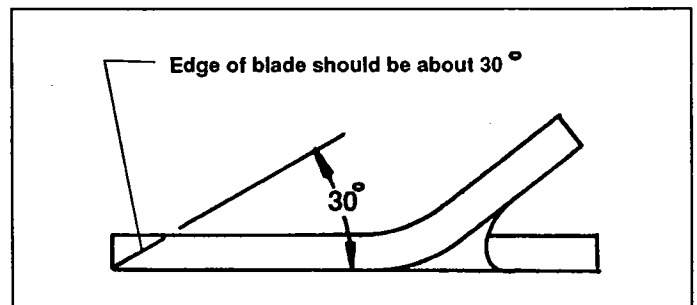

### Curb Climbing

When driving rider up and over a curb, drive in reverse at an angle so that the back drive wheels go over the curb one at a time. When both drive wheels are over the curb, turn machine so that both front caster wheels contact the curb at the same time.

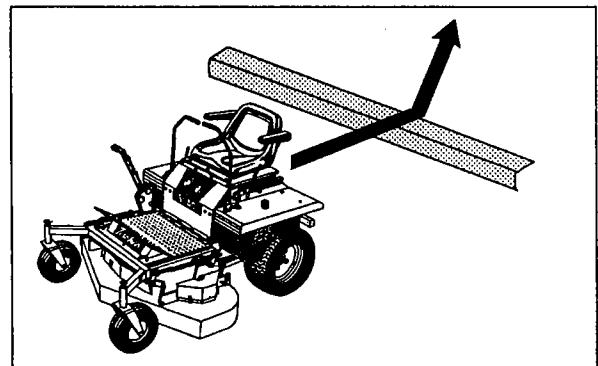

## LUBRICATION & MAINTENANCE

Break-In	8 Hours (Daily)	40 Hours (Weekly)	100 Hours (Biweekly)	200 Hours (Monthly)	PROCEDURE	COMMENTS
X	X				Check all hardware for proper tightness Change engine oil and filter at 5 hours Change hydrostatic oil and filter at 20 hours **	Fill to dipstick fill mark - SAE 10W30
X	X	X			Check engine oil Clean hydro oil cooler radiator Remove debris from under belt cover Sharpen cutter blades Grease spindle bearings 2 pumps of hand gun Clean air filter	Do not over fill MORE OFTEN IF NEEDED " " " " + US Lithium MP White Grease 2125 MORE OFTEN IF NEEDED
X	X	X			Check battery acid level Check tire pressure Change engine oil	Distilled water only Add or adjust as required See engine mfg. information
X	X	X	X		Replace air filter - quality Grease caster wheel bearings Grease caster wheel pivots Grease idler arm pivots Grease cutter deck frame pivots Grease deck lift bellcranks Grease push arms Grease control levers Grease neutral cams Grease height control pivot Grease blade engagement arm pivots	MORE OFTEN IF NEEDED Chassis grease Qty 2 Chassis grease Qty 2 Chassis grease Qty 3 Chassis grease Qty 2 Chassis grease Qty 4 Chassis grease Qty 2 Chassis grease Qty 2 Chassis grease Qty 2 Chassis grease Qty 1 Chassis grease Qty 2
X	X	X	X	X	Check all hardware for proper tightness Change engine oil filter Check hydro fluid resevoir level Clean and Adjust spark plugs	See engine mfg. information Adjust as needed - SAE 10W30 See engine mfg. information
					<b>Every 500 Hours</b>  Drain Hydraulic System and replace fluid Change hydrostatic oil filter	Use SAE 10W30 motor oil Clean area before removing filter

\* Depending on climate and enviroment, lubrication may be required every 8 to 40 hours.

\* Do not over grease as this may damage seal.

+ Compatible Greases:

Lidok EP #2 found at Industrial Shops

Ronex MP found at Exxon Service Stations

Shell Alvania found at Shell Service Stations

Mobilux #2 found at Mobil Service Stations

Super Lube M EP #2 and Super Lube-M #2 found at Conoco Service Stations

\*\* Important: Use only Scag Authorized parts for proper filtration

## SMZ-61 CUTTER DECK

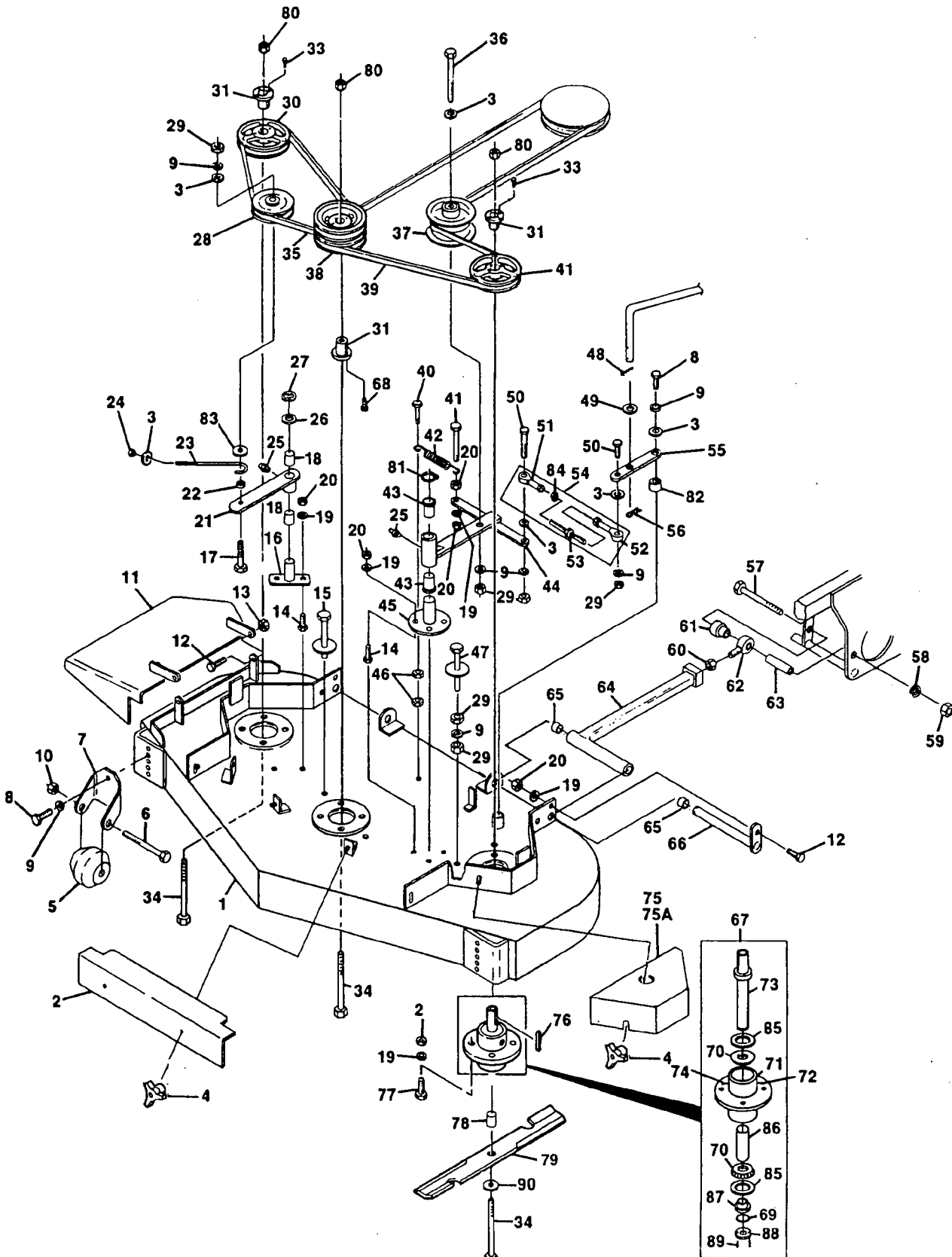

## SMZ-61 CUTTER DECK

Ref. Part No.	Part Number	Description	Ref. Part No.	Part Number	Description
1	46465	Cutter Deck (Includes decals)	47	45351	Belt Guide
2	42931	Belt Cover - Front	48	*	Cotter Pin, 3/32 x 1"
3	*	Flat Washer, 3/8"	49	*	Flat Washer, 1/2"
4	04029-03	Wing Nut, 3/8-16	50	*	Hex Head Bolt, 3/8-16 x 1-1/4"
5	48584	Anti-Scalp Wheel	51	48464	Ball Joint - RH
6	*	Hex Head Bolt, 5/8-11 x 4-1/2"	52	48544	Ball Joint - LH
7	42882	Anti-Scalp Wheel Bracket	53	48590	Link, Tumbuckle
8	*	Hex Head Bolt, 3/8-16 x 1"	54	46388	Turnbuckle Assembly
9	*	Lockwasher, 3/8"	55	421107	Declutch Link, Cutter Engagement
10	*	Hex Nut, 5/8-11 Elastic Stop	56	04062-01	Hair Pin, 1/8" Dia.
11	45440	Discharge Chute	57	*	Hex Head Bolt, 1/2-13 x 5-1/2"
12	*	Hex Head Bolt, 5/16-18 x 1"	58	*	Lockwasher, 1/2"
13	*	Hex Nut, 5/16-18 Elastic Stop	59	*	Hex Nut, 1/2-13
14	*	Hex Head Bolt, 5/16-18 x 3/4"	60	*	Hex Nut, 5/8-18 UNF
15	45350	Belt Guide	61	43244	Bushing
16	45037	Idler Pivot Base	62	48763	Rod End
17	*	Hex Head Bolt, 3/8-16 x 2-1/4"	63	43243	Spacer
18	48100-05	Bushing	64	46460	Push Arm (Includes 25, 60, 62, & 65)
19	*	Lockwasher, 5/16"	65	48100-06	Bushing
20	*	Hex Nut, 5/16-18	66	45332	Push Arm Shaft
21	46081	Idler Arm (Includes bushings & grease ftg.)	67	46400	Cutter Spindle Assy (Complete, Tapered)
22	43077	Spacer	68	*	Hex Head Bolt, 1/4-20 x 1-1/4"
23	43028	"J" Rod	69	04050-04	Retaining Ring, 1" Ext Inverted
24	*	Hex Nut, 3/8-16 Elastic Stop	70	48668	Bearing & Cup, Tapered Spindle
25	48114-04	Grease Fitting	71	41008	Spindle Housing, Tapered Spindle
26	04041-08S	Flat Washer, 3/4" Special	72	48114-02	Grease Fitting
27	04050-02	Retaining Ring, 3/4" External "E"	73	45391	Spindle Shaft, Tapered Spindle
28	48181	Pulley, Idler	74	48677	Relief Fitting, Tapered Spindle
29	*	Hex Nut, 3/8-16	75	421139	Belt Cover - RH
30	48127	Pulley (Includes Items 31 & 33)	75A	421138	Belt Cover - LH
31	48141	Tapered Hub	76	04063-08	Key, 1/4 x 1/4 x 2"
33	*	Hex Head Bolt, 1/4-20 x 3/4"	77	*	Hex Head Bolt, 5/16-18 x 1-1/4"
34	04001-41	Hex Head Bolt, 5/8-11 x 9-1/2"	78	43235	Spacer-Use With Taper Bearing Spindle
35	48265	Belt, RH Blade Drive	79	48111	Cutter Blade
36	*	Hex Head Bolt, 3/8-16 x 3-1/2"	80	*	Hex Nut, 5/8-11
37	48550	Pulley, Idler - Cutter Engagement	81	04050-05	Retaining Ring 1-1/8" Ext. E
38	48128	Pulley, Double (Includes 31)	82	43042	Sieve, Cam Clutch
39	48752	Belt, Blade Drive	83	04041-12	3/8 Flatwasher, 3/8 x 1-1/2 x .06
40	*	Hex Head Bolt, 1/4-20 x 1-1/4"	84	*	Hex Nut, 3/8-24 UNF
41	48753	Pulley, LH Spindle	85	48681	Seal, Cutter Spindle, Tapered
42	48494-02	Spring, Idler Tension	86	43218	Spacer, Tapered Spindle
43	48100-02	Bushing	87	43217	Bushing, Tapered Spindle
44	46387	Idler Arm (Includes bushings & grease ftg.)	88	43201	1/4" Blade Spacer, Tapered Spindle
45	45329	Idler Pivot Base	89	*	Roll Pin, 1/8 x 1/2"
46	*	Hex Nut, 1/4-20	90	04040-10	Flat Washer 5/8 x .688 x .175 x .134

\* Common hardware which should be purchased locally. All bolts Grade 5 plated, all other fasteners zinc plated.

## CUTTER DECK CONTROLS

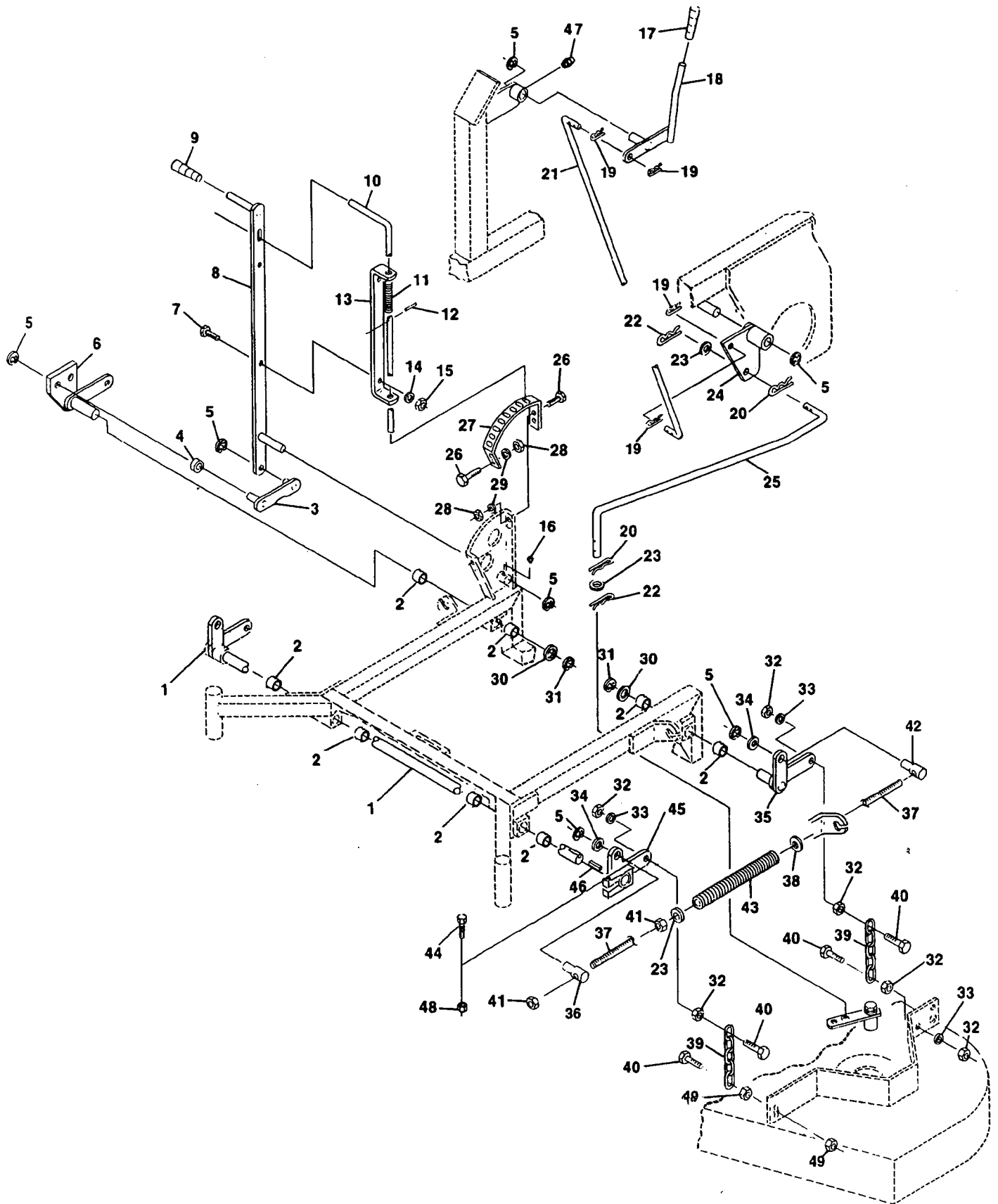

## CUTTER DECK CONTROLS

Ref. Part No.	Part Number	Description	Ref. Part No.	Part Number	Description
1	45426	Lift Arm Weldment	26	*	Hex Head Bolt, 1/4-20 x 3/4"
2	48100-05	Bushing	27	42828	Strip, Height Adjustment
3	45344	Lift Link	28	*	Hex Nut, 1/4-20
4	43180	Bushing	29	*	Lockwasher, 1/4"
5	04050-01	Retaining Ring, 5/8" External "E"	30	04041-08S	Flat Washer, 3/4" Special
6	45310	Bellcrank, Lift - Right Rear	31	04050-02	Retaining Ring, 3/4" External "E"
7	*	Hex Head Bolt, 5/16-18 x 1"	32	*	Hex Nut, 3/8-16
8	46384	Height Adjustment Lever (Includes grip)	33	*	Lockwasher, 3/8"
9	48093	Grip, Lift Lever	34	*	Flat Washer, 5/8"
10	44065	Rod, Cutter Deck Lock	35	45313	Bellcrank, Lift - Left Rear
11	48053	Spring, Deck Lift Index	36	43167	Swivel Joint - RH
12	04060-01	Roll Pin, 5/32 x 3/4"	37	04004-12	Adjustment Stud
13	42887	Lock Rod Guide	38	04040-10	Flat Washer, 5/8" ID
14	*	Lockwasher, 5/16"	39	48540	Chain
15	*	Hex Nut, 5/16-18	40	*	Hex Head Bolt, 3/8-16 x 1-1/2"
16	48114-04	Grease Fitting	41	*	Hex Nut, 1/2-13
17	48144	Grip, Blade Clutch Lever	42	43168	Swivel Joint - LH
18	46385	Lever, Cutter Engagement (Includes grip)	43	48546	Spring, Deck Lift
19	04062-02	Hair Pin, 1/16" Dia.	44	*	Hexhead Bolt, 3/8-16 x 2"
20	04061-01	Cotter Pin, 3/32 x 1"	45	45427	Bellcrank, Lift - Left Front
21	44060	Rod, Cutter Engagement - Upper	46	04063-17	Key, 3/16 x 3/16 x 1"
22	04062-01	Hair Pin, 1/8" Dia.	47	48114-05	Grease Fitting
23	*	Flat Washer, 1/2"	48	*	Hex Nut, 3/8-16 Elastic Stop
24	45307	Bellcrank, Cutter Engagement	49	04019-04	Nut, 3/8-16 Serrated Flange
25	44061	Rod, Cutter Engagement - Lower			

\* Common hardware which should be purchased locally. All bolts Grade 5 plated, all other fasteners zinc plated.

## SHEET METAL COMPONENTS

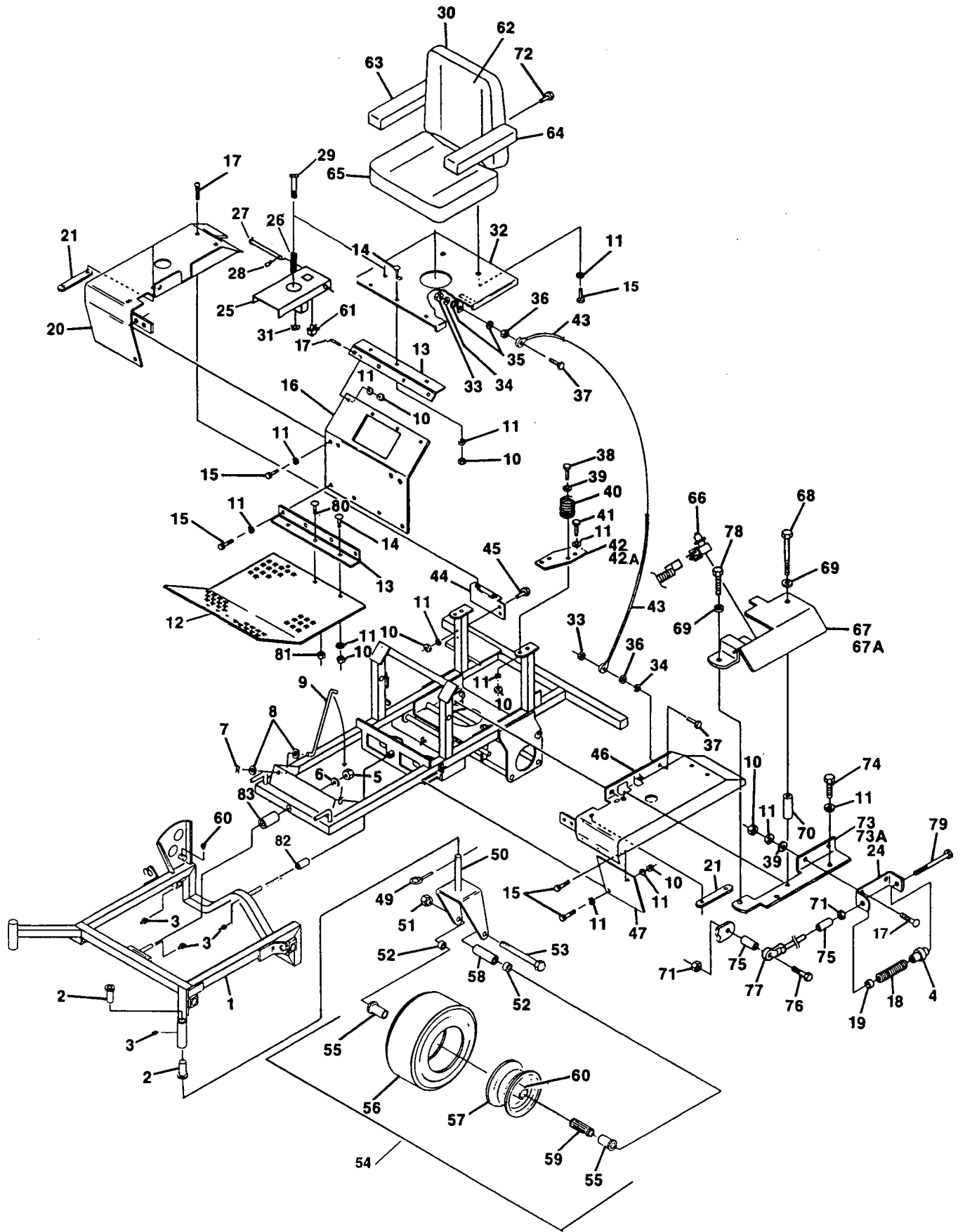



## SHEET METAL COMPONENTS

Ref. No.	Part Number	Description	Ref. No.	Part Number	Description
1	46466	Cutter Deck Support Frame Assembly	43	48716	Cable, Seat Stop
2	48100-08	Bushing	44	42885	Fender Bracket - RH & LH
3	48114-04	Grease Fitting	45	*	Hex Head Bolt, 5/16-18 x 2-1/2"
4	43150	Spacer, Long	46	46469	Fender Assembly - LH (w/decals)
5	*	Hex Nut, 3/4-16 Elastic Stop	47	42901	LH Fender Extension
6	*	Flat Washer, 3/4"	48	<b>46392</b>	<b>Caster Wheel Assembly, Complete</b>
7	04062-02	Hair Pin, 1/16" Dia	49	04066-01	Quick Pin
8	*	Flat Washer, 3/8"	50	45325	Caster Wheel Yoke
9	44062	Rod, Foot Plate Latch	51	*	Hex Nut, 1/2-13 Elastic Stop
10	*	Hex Nut, 5/16-18	52	43041	Spacer
11	*	Lockwasher, 5/16"	53	*	Hex Head Bolt, 1/2-13 x 6-1/2"
12	42764	Foot Plate	54	<b>48537</b>	<b>Wheel Assembly, Complete</b>
13	48547	Hinge	55	48006-07	Retainer
14	*	Carriage Bolt, 5/16-18 x 3/4"	56	48537-02	Tire Only
15	*	Hex Head Bolt, 5/16-18 x 3/4"	57	48537-03	Rim Only
16	421170	Kick Plate	58	43022	Sleeve
17	*	Carriage Bolt, 5/16-18 x 1"	59	48006-06	Roller Bearing
18	48746	Neutral Return Spring	60	48114-05	Grease Fitting
19	43151	Spacer, Short	61	48717	Seat Switch
20	46468	Fender Assembly - RH (w/decals)	62	48704-02	Seat Back Cushion
21	42888	Neutral Lock Bar	63	48704-04	Arm Pad - RH
22	+	Number not used on illustration	64	48704-05	Arm Pad - LH
23	+	Number not used on illustration	65	48704-03	Cushion Assembly
24	421148	Retainer, Neutral Spring	66	48522	Neutral Interlock Switch
25	45405	Seat Switch Bracket	67	421136	RH Neutral Lock Bracket
26	48463	Spring	67A	421137	LH Neutral Lock Bracket
27	04064-04	Clevis Pin	68	*	Bolt, Hex Head, 5/16-18 x 2-3/4"
28	04062-02	Hair Pin Cotter	69	*	Flat Washer, 5/16"
29	*	Hex Head Bolt, 5/16-18 x 3-3/4"	70	43242	Spacer, Neutral Lock Bracket
30	48831	Seat	71	*	Hex Nut, 3/8-24 UNF
31	*	Hex Nut, 5/16-18 Elastic Stop	72	48704-06	Hex Head Screw w/Washer, 1/4-20 x 3/4"
32	45404	Seat Base	73	421146	LH Neutral Control Mounting Bracket
33	*	Hex Nut, 1/4-20 Elastic Stop	73A	421147	RH Neutral Control Mounting Bracket
34	*	Lockwasher, 1/4"	74	*	Bolt, Hex Head, 3/8-16 x 3/4"
35	*	Flat Washer, 1/4"	75	43240	Spacer Neutral Spring
36	*	Hex Nut, 1/4-20	76	*	Hex Head Bolt, 3/8-16 x 2-1/4"
37	*	Hex Head Bolt, 1/4-20 x 1"	77	48464	Ball Joint, Neutral
38	*	Hex Head Bolt, 5/16-18 x 1-1/4"	78	*	Hex Head Bolt, 5/16-18 x 3/4"
39	*	Flat Washer, 5/16"	79	04001-99	Hex Head Bolt, 3/8-24 x 6-1/2 UNF
40	48686	Seat Spring	80	*	Carriage Bolt, 5/16-18 x 1/2"
41	*	Hex Head Bolt, 5/16-18 x 1"	81	*	Center Lock Nut, 5/16-18
42	42919	Oil Cooler Mounting Bracket - LH	82	48100-10	Bushing
42A	42920	Oil Cooler Mounting Bracket - RH	83	48100-09	Bushing

\* Common hardware which should be purchased locally. All bolts Grade 5 plated, all other fasteners zinc plated.

## HYDRAULIC COMPONENTS

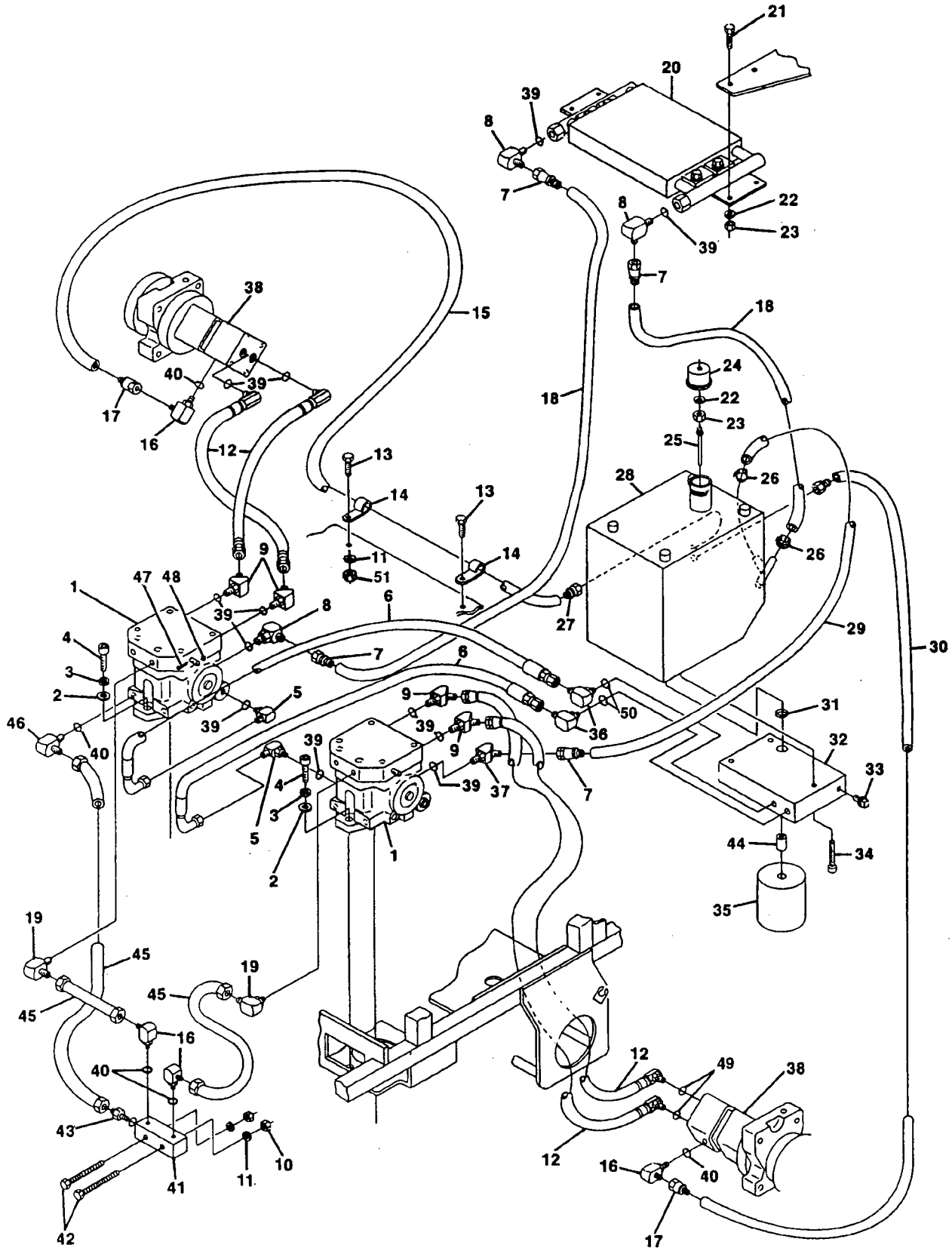

## HYDRAULIC COMPONENTS

Ref. Part No.	Part Number	Description	Ref. Part No.	Part Number	Description
1	48597	Pump, Sundstrand	27	48352-02	Coupling, 1/4 NPT to 1/4 ID Hose
2	04041-04	Flat Washer (.516 x .937 x .105)	28	45309	Oil Reservoir
3	*	Lockwasher, 1/2"	29	48504-05	Hose, 5/8" ID - 16" Long
4	04015-03	Capscrew, Socket Hd., 5/16-18 x 3/4"	30	48482-10	Hose, 1/4" ID - 14 1/2" Long
5	48350-07	Elbow 90 deg., 1-1/16-12 JIC to 3/4-16 "O"	31	48603-01	"O" Ring, 1/8 x 1" ID
6	48622	Hose Assembly, Pump Suction	32	48599	Oil Manifold
7	48353-04	Coupling, 7/8-14 SAE Flare to 5/8 ID Hose	33	48731-02	Pipe Plug, 1/2 NPT Magnetic
8	48350-05	Elbow 90 deg., 7/8-14 JIC to 3/4-16 "O"	34	04015-04	Capscrew, Socket Hd., 3/8-16 x 2"
9	48485-01	Elbow 45 deg., 3/4-16 JIC to 3/4-16 "O"	35	48606	Oil Filter
10	*	1/4-20 Elastic Stop Nut	36	48350-08	Elbow 90 deg.
11	*	Lockwasher, 1/4"	37	48485-04	Elbow 45 deg., 7/8-14 JIC to 3/4-16 "O"
12	48501	Hose Assembly, Pump to Motor	38	48769	White Motor
13	*	Hex Head Bolt, 1/4-20 x 3/4"	39	48603-02	"O" Ring, 3/32 x 5/8" ID
14	48030-09	Hose Clamp	40	48603-03	"O" Ring 1/16 x 3/8" ID
15	48482-11	Hose, 1/4" ID - 31 1/2" Long	41	48772	E-Z Ride Valve
16	48485-03	Elbow 90 deg., 7/16-20 JIC to 7/16-20 "O"	42	*	Hex Head Bolt, 1/4-20 x 1-3/4"
17	48353-02	Coupling, 7/8-14 SAE Flare to 1/4 ID Hose	43	48483-01	Union Tube, 7/16-20
18	48504-07	Hose, 5/8" ID - 18-1/2" Long	44	48643	Nipple, Oil Filter
19	48489-04	Elbow 90 deg., 1/8 NPT x 7/16-20 JIC	45	48764	Hose Assembly, E-Z Ride Valve
20	48645	Oil Cooler	46	48350-04	Elbow 90 deg. 7/16-20 JIC to 9/16-18 "O"
21	*	Hex Head Bolt, 5/16-18 x 3/4"	47	*	Screw, Phillips Head, 1/4-20 x 2"
22	*	Lockwasher, 5/16"	48	*	Hex Nut, 1/4-20 Elastic Stop
23	*	Hex Nut, 5/16-18	49	48603-04	"O" Ring, 3/32 x 3/4"
24	48630	Cap, Oil Reservoir	50	48603-05	"O" Ring, 1/8 x 15/16"
25	43198	Dip Stick	51	*	Hex Nut, 1/4-20
26	48136-04	Hose Clamp			

\* Common hardware which should be purchased locally. All bolts Grade 5 plated, all other fasteners zinc plated.

## TRACTION DRIVE COMPONENTS

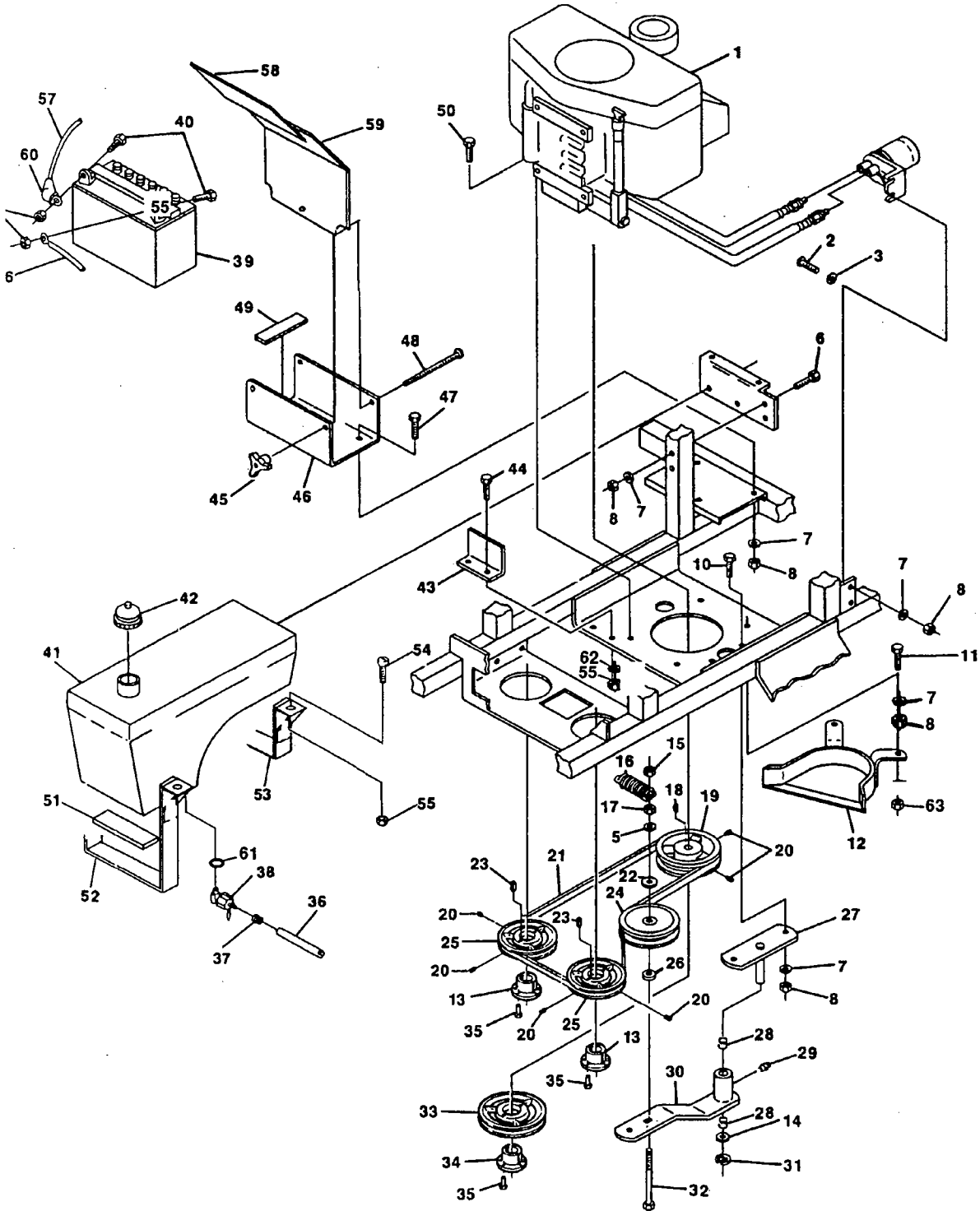

## TRACTION DRIVE COMPONENTS

Ref. Part No.	Part Number	Description	Ref. Part No.	Part Number	Description
1	48558	Engine, 20 HP Kohler	33	48378	Pulley, Engine - Cutter Drive
2	*	Carriage Bolt, 5/16-18 x 1"	34	48378-03	Hub, Pulley
3	*	Flat Washer, 5/16"	35	*	Hex Head Bolt, 1/4-20 x 1-3/8"
4	*	Hex Head Bolt, 3/8-16 x 1"	36	48058-02	Fuel Hose, 14-1/8" Long
5	*	Lockwasher, 3/8	37	48059-01	Clamp, Fuel Hose
6	*	Hex Head Bolt, 5/16-18 x 2-3/4"	38	48308	Fuel Shut off Valve
7	*	Lockwasher, 5/16"	39	48015	Battery
8	*	Hex Nut, 5/16-18	40	*	Hex Head Bolt, 1/4-20 x 1/2"
9	*	Center Locknut, 3/8-16	41	48651	Fuel Tank Assembly (Includes 38 & 61)
10	*	Hex Head Bolt, 5/16-18 x 1"	42	48658	Fuel Tank Cap w/Gauge
11	*	Hex Head Bolt, 5/16-18 x 2"	43	42918	Heat Deflector
12	45352	Belt Guide	44	*	Hex Head Bolt, 1/4-20 x 3/4"
13	48761	Tapered Hub, 3/4" Bore	45	04029-01	Wingnut, 1/4-20
14	04041-08S	Washer	46	42802	Plate, Battery Box
15	*	Elastic Stop Nut, 3/8-16	47	*	Hex Head Bolt, 5/16-18 x 3/4"
16	48755	Spring, Idler Arm	48	*	Carriage Bolt, 1/4-20 x 6"
17	*	Hex Nut, 3/8-16	49	48661	Pad, Battery Support
18	04063-11	Key, 1/4 x 1/4 x 2-1/2"	50	*	Hex Head Bolt, 5/16-18 x 1-1/2"
19	48747	Pulley, Engine - Pump Drive	51	48657	Rubber Pads, Gas Tank
20	04012-04	Setscrew, 5/16-18 x 3/8 Hex Socket Head	52	42944	Fuel Tank Strap, Long
21	48749	Belt, Pump Drive	53	42945	Fuel Tank Strap
22	*	Flat, Washer, 3/8"	54	*	Machine Screw, 1/4-20 x 2"
23	04063-12	Key, Woodruff #61	55	*	Nut, 1/4-20
24	48068	Pulley, Idler Pump Drive	56	48029-01	Battery Cable, Black 13-3/4"
25	48748	Pulley, Pump Shaft	57	48029-02	Battery Cable, Red 30-3/4"
26	*	Flat Washer, 3/8 x 12 ga.	58	48099	Battery Cover Pad
27	45212	Idler Pivot	59	42392	Battery Cover
28	48100-05	Bushing	60	48126	Rubber Boot
29	48114-04	Grease Fitting	61	48309	Bushing
30	46467	Idler Arm (Includes bushings & grease ftg.)	62	*	Lockwasher, 1/4"
31	04050-02	Retaining Ring, 3/4 External "E"	63	*	Elastic Stop Nut, 5/16-18
32	04001-81	Hex Head Bolt, 3/8-16 x 3-1/2 Full Thread			

\* Common hardware which should be purchased locally. All bolts Grade 5 plated, all other fasteners zinc plated.

## BRAKE AND STEERING CONTROLS

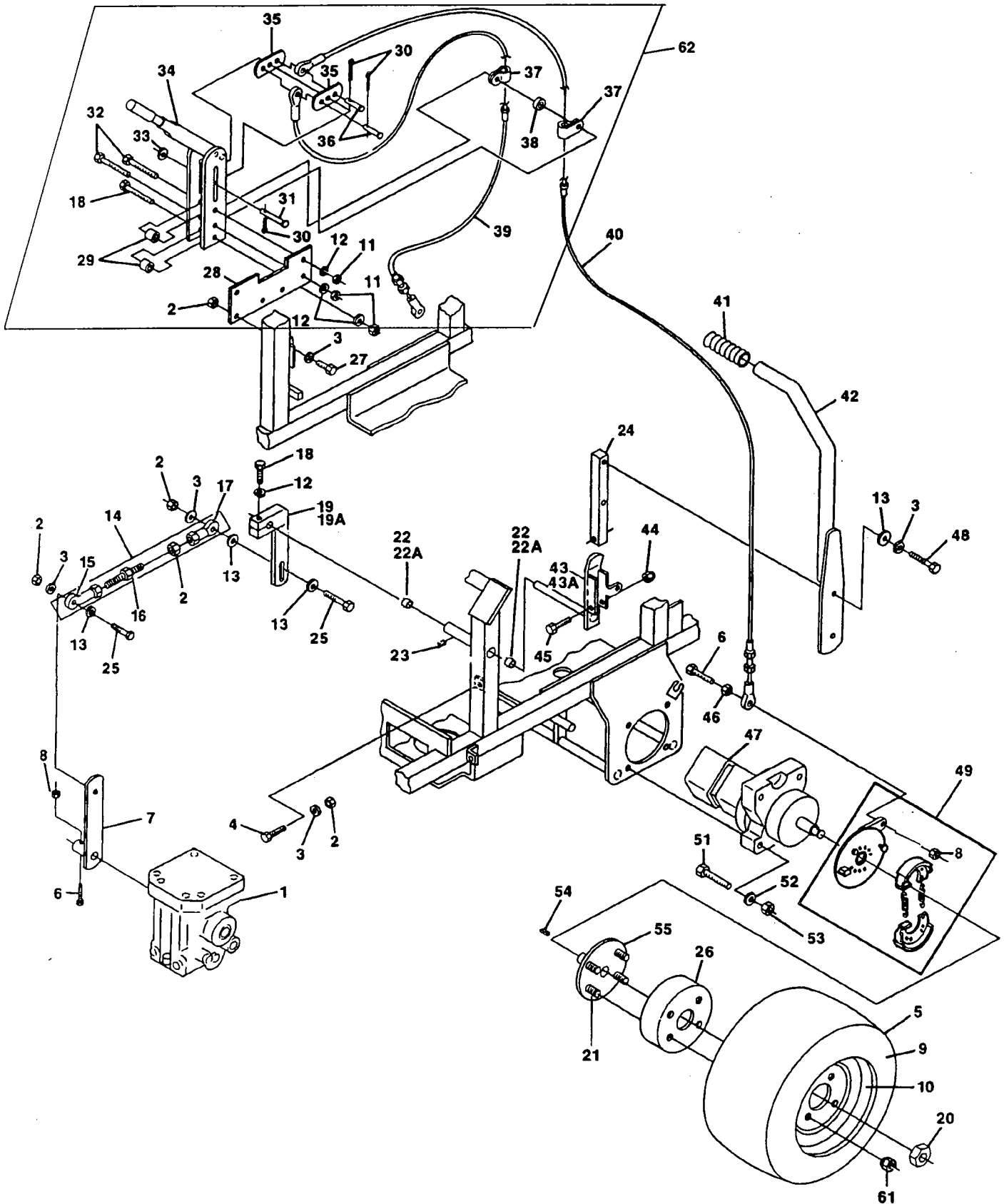

## BRAKE AND STEERING CONTROLS

Ref. No.	Part Number	Description	Ref. No.	Part Number	Description
1	48597	Pump, Sundstrand	31	48574-03	Pin
2	*	Hex Nut, 3/8-16	32	*	Hex Head Bolt, 5/16-18 x 2"
3	*	Lockwasher, 3/8"	33	48574-04	Washer
4	*	Hex Head Bolt, 3/8-16 x 1-1/4"	34	48574	Brake Lever Only
5	48554	Wheel Assembly	35	48574-05	Equalizer
6	*	Hex Head Bolt, 1/4-20 x 1-1/4"	36	48574-06	Pin
7	45432	Lever, Pump Control	37	48574-07	Clamp
8	*	Hex Nut, 1/4-20 Elastic Stop	38	48574-08	Spacer
9	48554-01	Tire Only	39	48549	Brake Cable - RH
10	48416-04	Rim Only	40	48548	Brake Cable - LH
11	*	Hex Nut, 5/16-18	41	48093	Grip, Control Handle
12	*	Lockwasher, 5/16"	42	45437	Control Handle
13	04041-07	Flat Washer, 3/8 (.391 x .938 x .105)	43	45436	Control Lever - RH
14	46388	Turnbuckle Assembly	43A	45435	Control Lever - LH
15	48544	Ball Joint, LH Thread	44	*	Hex Nut, 5/16-18 Elastic Stop
16	48590	Link, Turnbuckle	45	*	Hex Head Bolt, 5/16-18 x 1-1/2"
17	48464	Ball Joint, RH Thread	46	*	Hex Nut, 1/4-20
18	*	Hex Head Bolt, 5/16-18 x 1-3/4"	47	48769	Motor, White
19	45434	Lever, Pump Transfer - RH	48	*	Hex Head Bolt, 3/8-16 x 1"
19A	45433	Lever, Pump Transfer - LH	49	48461	Parking Brake Assembly
20	48813	Spring Lock Nut	50	*	Lockwasher, 1/4"
21	04008-01	Serrated Bolt, 1/2-20	51	*	Hex Head Bolt, 1/2-13 x 2-1/2"
22	48100-06	Bushing - LH	52	*	Lockwasher, 1/2"
22A	48100-05	Bushing - RH	53	*	Hex Nut, 1/2-13
23	48114-04	Grease Fitting	54	04063-16	Key, 5/16 x 5/16 x 15/16"
24	421145	Bar Control Lever	55	46332	Wheel Hub Assembly
25	*	Hex Head Bolt, 3/8-16 x 1-1/2"	56	48513	Brake Drum
26	48513	Brake Drum	57	48554	Wheel Assembly
27	*	Hex Head Bolt, 3/8-16 x 1"	58	48554-01	Tire Only
28	42884	Brake Extension Bar	59	48416-04	Rim Only
29	48574-01	Spacer	61	04028-01	Lug Nut, 1/2-20
30	48574-09	Cotter Pin	62	48625	Brake Lever w/Cables

\* Common hardware which should be purchased locally. All bolts Grade 5 plated, all other fasteners zinc plated.

## INSTRUMENT PANEL AND ELECTRICAL COMPONENTS

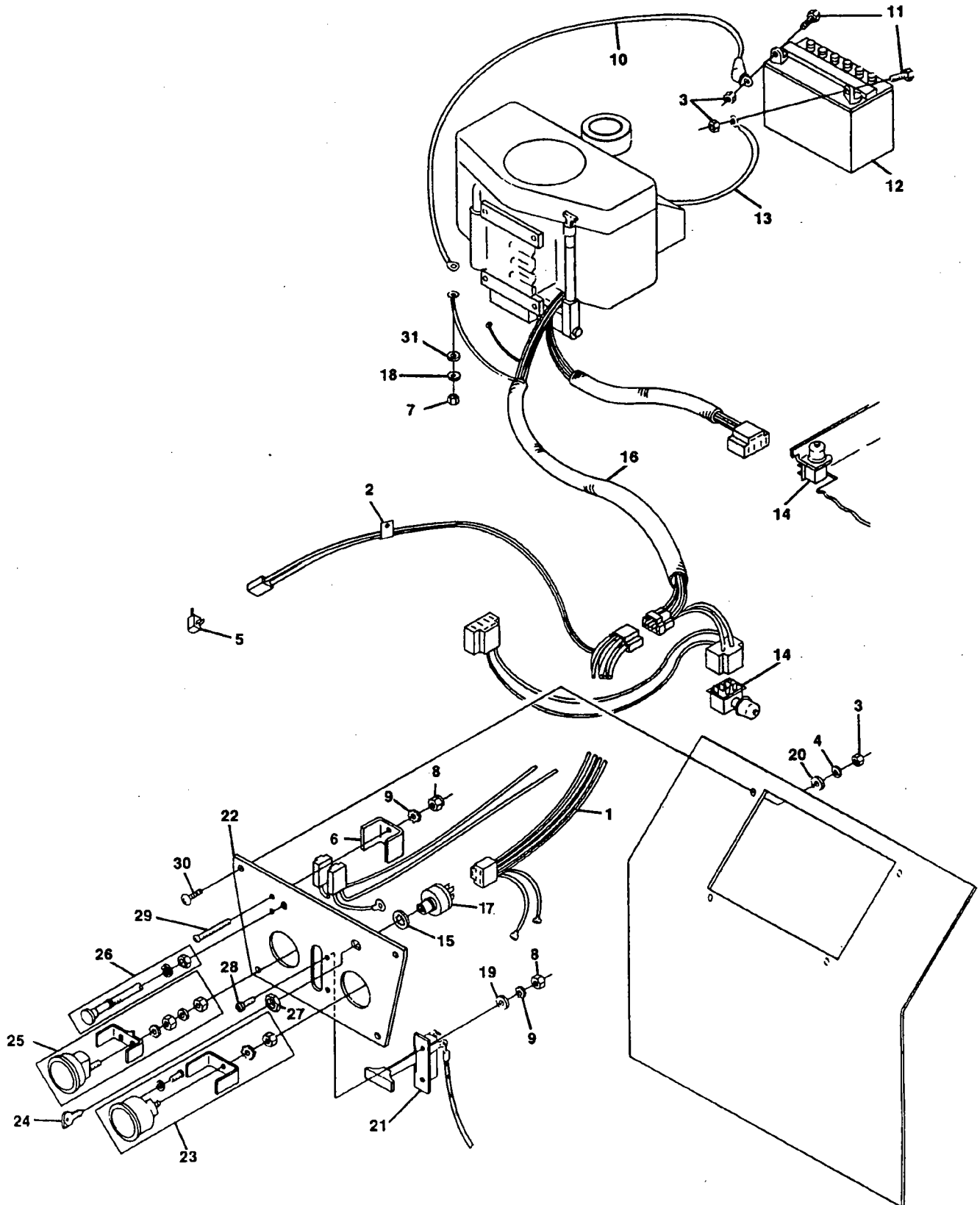



## INSTRUMENT PANEL AND ELECTRICAL COMPONENTS

Ref. No.	Part Number	Description	Ref. No.	Part Number	Description
1	48518	Wire Harness, instrument panel	17	48017	Switch, Ignition
2	48030-09	Clamp	18	*	Lockwasher, 5/16"
3	*	Hex Nut, 1/4-20	19	*	Flat Washer #10
4	*	Lockwasher, 1/4"	20	*	Flat Washer 1/4"
5	48717	Switch, Seat	21	48519	Throttle Control
6	42413	Bracket, Fuse Holder	22	421170	Kick Plate
7	*	Hex Nut, MS-Metric	23	48023	Hourmeter (includes hardware)
8	*	Hex Nut, #10-32	24	48017-02	Ignition Key
9	*	Lockwasher, #10 External Tooth	25	48022	Ammeter (includes hardware)
10	48029-02	Battery Cable - 30-3/4" (Red)	26	48091	Choke Control
11	*	Hex Head Bolt, 1/4-20 x 1/2"	27	48017-04	Hex Nut, 5/8-11
12	48015	Battery	28	*	Screw, Phillips Washer Hd, #10-32 x 1/2"
13	48029-01	Battery Cable - 13-3/4" (Black)	29	*	Screw, Phillips Washer Hd, #10-32 x 1-1/2"
14	48522	Switch, Cutter Deck Engage	30	*	Screw, Phillips Pan Head, 1/4-20 x 3/4"
15	48017-03	Lock Washer, 5/8" Internal Tooth	31	*	Flat Washer, 5/16"
16	48751	Wire Harness - Lower			

\* Common hardware which should be purchased locally. All bolts Grade 5 plated, all other fasteners zinc plated.

## WIRING DIAGRAM

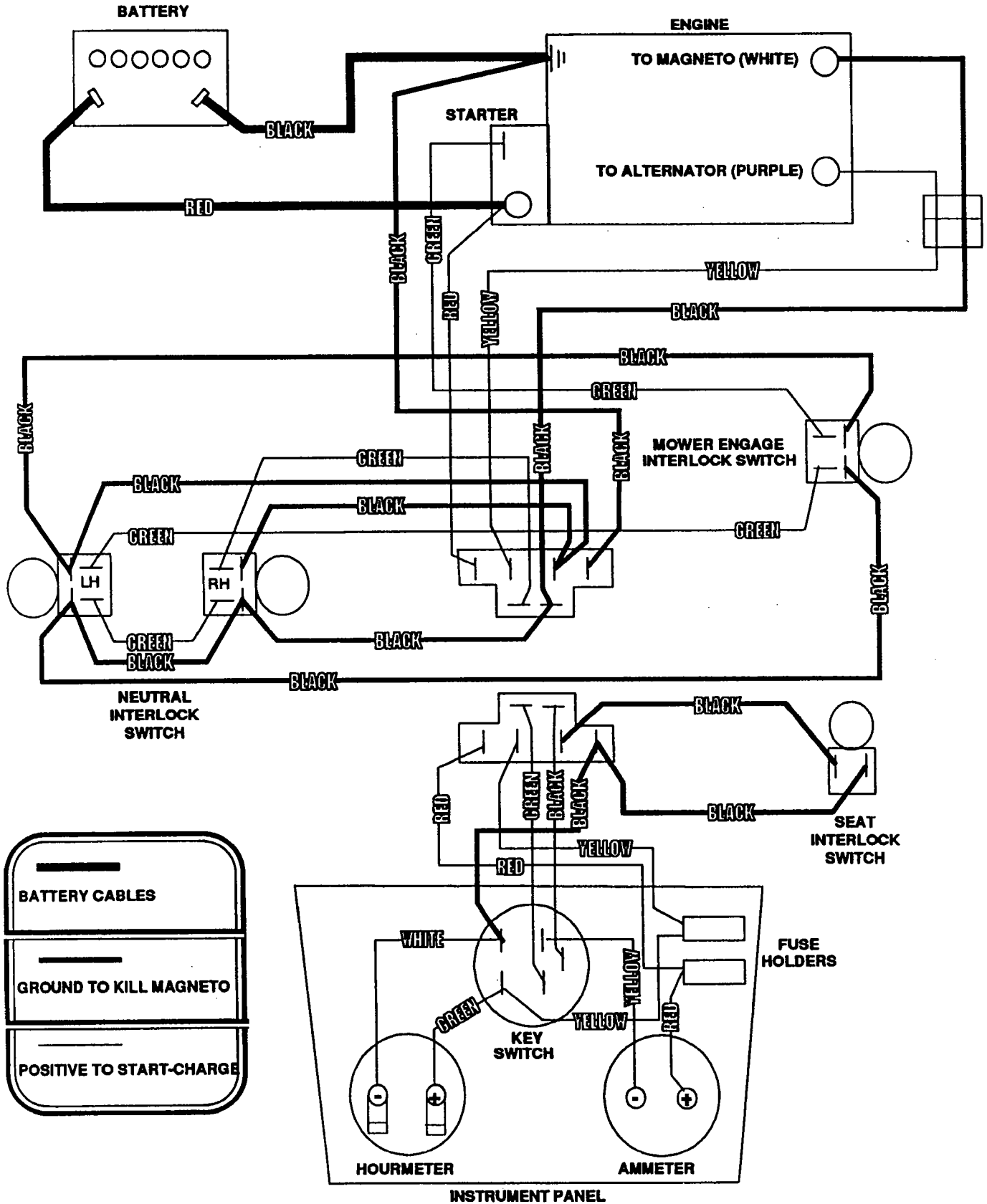

## REPLACEMENT DECALS



48520



48555



48623



48556



48775

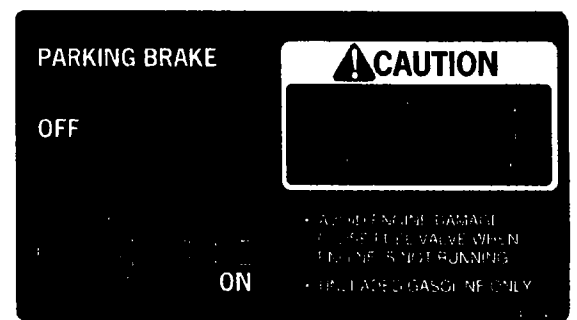

48774



48712

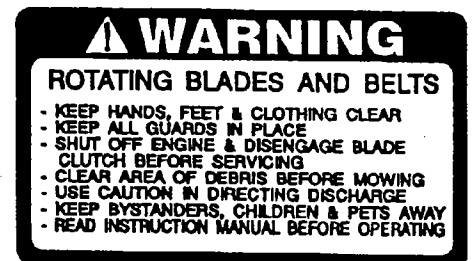

48073



48071

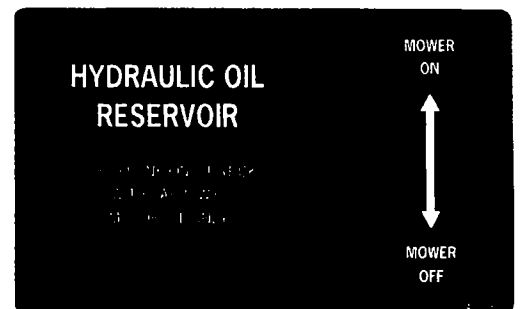

48773



48319



48404



48072

## WARNING

If incorrectly used, this machine can cause severe injury. Those who use and maintain the machine should be trained in its proper use, warned of its dangers, and should read the entire manual before attempting to set up, operate, adjust or service the machine.

### LIMITED WARRANTY-COMMERCIAL EQUIPMENT

Any part of the Scag commercial mower manufactured by Scag and found, in the reasonable judgment of Scag, to be defective in materials or workmanship, will be repaired or replaced by an Authorized Scag Service Dealer without charge for parts and labor. This warranty is limited to the original purchaser and is not transferable. Proof of purchase will be required by the dealer to substantiate any warranty claims. All warranty work must be performed by an Authorized Scag Service Dealer.

This warranty is limited to the following specified periods from the date of the original retail purchase for defects in materials or workmanship:

- \* Frame, deck and structural components including oil reservoirs - 1 year
- \* Wear items including drive belts, blades, hoses and tires are warranted for 90 days
- \* Engines and electric starters are covered by the manufacturer's warranty period.
- \* Drive system components are covered by the manufacturer's warranty period.  
(Excluding fittings, hoses, cooling system, oil reservoir, drive belts). Drive systems are warranted by Scag Power Equipment in conjunction with the component manufacturer.
- \* Batteries are covered for 1 year.
- \* Any Scag product used for rental purposes is covered for 90 days.

The Scag mower, including any defective part must be returned to an Authorized Scag Service Dealer within the warranty period. The expense of delivering the mower to the dealer for warranty work and the expense of returning it to the owner after repair will be paid for by the owner. Scag's responsibility is limited to making the required repairs and no claim of breach of warranty shall be cause for cancellation or rescission of the contract of sale of any Scag mower.

This warranty does not cover any mower that has been subject to misuse, neglect, negligence, or accident, or that has been operated in any way contrary to the operating instructions as specified in the Technical Manual. The warranty does not apply to any damage to the mower that is the result of improper maintenance, or to any mower or parts that have not been assembled or installed as specified in the Technical Manual. The warranty does not cover any mower that has been altered or modified changing performance or durability. In addition, the warranty does not extend to repairs made necessary by normal wear, or by the use of parts or accessories which, in the reasonable judgment of Scag, are either incompatible with the Scag mower or adversely affect its operation, performance or durability.

Scag Power Equipment reserves the right to change or improve the design of any mower without assuming any obligation to modify any mower previously manufactured.

All other implied warranties are limited in duration to the one (1) year warranty period or ninety (90) days for mowers used for rental purpose. Accordingly, any such implied warranties including merchantability, fitness for a particular purpose, or otherwise, are disclaimed in their entirety after the expiration of the appropriate one year or ninety day warranty period. Scag's obligation under this warranty is strictly and exclusively limited to the repair or replacement of defective parts and Scag does not assume or authorize anyone to assume for them any other obligation. Some states do not allow limitations on how long an implied warranty lasts, so the above limitation may not apply to you.

Scag assumes no responsibility for incidental, consequential or other damages including, but not limited to, expense for gasoline, expense of delivering the mower to an Authorized Scag Service Dealer and expense of returning it to the owner, mechanic's travel time, telephone or telegram charges, rental of a like product during the time warranty repairs are being performed, travel, loss or damage to personal property, loss of revenue, loss of use of the mower, loss of time or inconvenience. Some states do not allow the exclusion or limitation of incidental or consequential damages. So the above limitation or exclusion may not apply to you.

This warranty gives you specific legal rights, and you may also have other rights which vary from state to state.

## PLEASE BE CAREFUL

1. Keep all shields in place, especially grass discharge guard.
2. Stop machine and remove spark plug wire to adjust or service.
3. When mechanism becomes clogged, stop engine before cleaning.
4. Keep hands, feet and clothing away from power-driven parts.
5. Keep off implement unless seat or platform is provided.
6. Keep others off of the tractor (only one person at a time).

**REMEMBER - YOUR MOWER IS ONLY AS SAFE AS THE OPERATOR!**

**FAILURE TO FOLLOW CAUTIOUS OPERATING PRACTICES MAY RESULT IN SERIOUS BODILY INJURY. BESIDES, WE WOULD LIKE YOU TO CONTINUE TO ENJOY AND PROFIT BY USING OUR PRODUCTS.**

### OWNER REFERENCE

TRACTOR MODEL \_\_\_\_\_

TRACTOR SERIAL NUMBER \_\_\_\_\_

MOWER MODEL \_\_\_\_\_

MOWER SERIAL NUMBER \_\_\_\_\_

## Free Manuals Download Website

<http://myh66.com>

<http://usermanuals.us>

<http://www.somanuals.com>

<http://www.4manuals.cc>

<http://www.manual-lib.com>

<http://www.404manual.com>

<http://www.luxmanual.com>

<http://aubethermostatmanual.com>

Golf course search by state

<http://golfingnear.com>

Email search by domain

<http://emailbydomain.com>

Auto manuals search

<http://auto.somanuals.com>

TV manuals search

<http://tv.somanuals.com>