

SCAG
POWER EQUIPMENT

OPERATOR'S MANUAL

MODEL STHM

FROM SERIAL NUMBER 50001 TO 59999

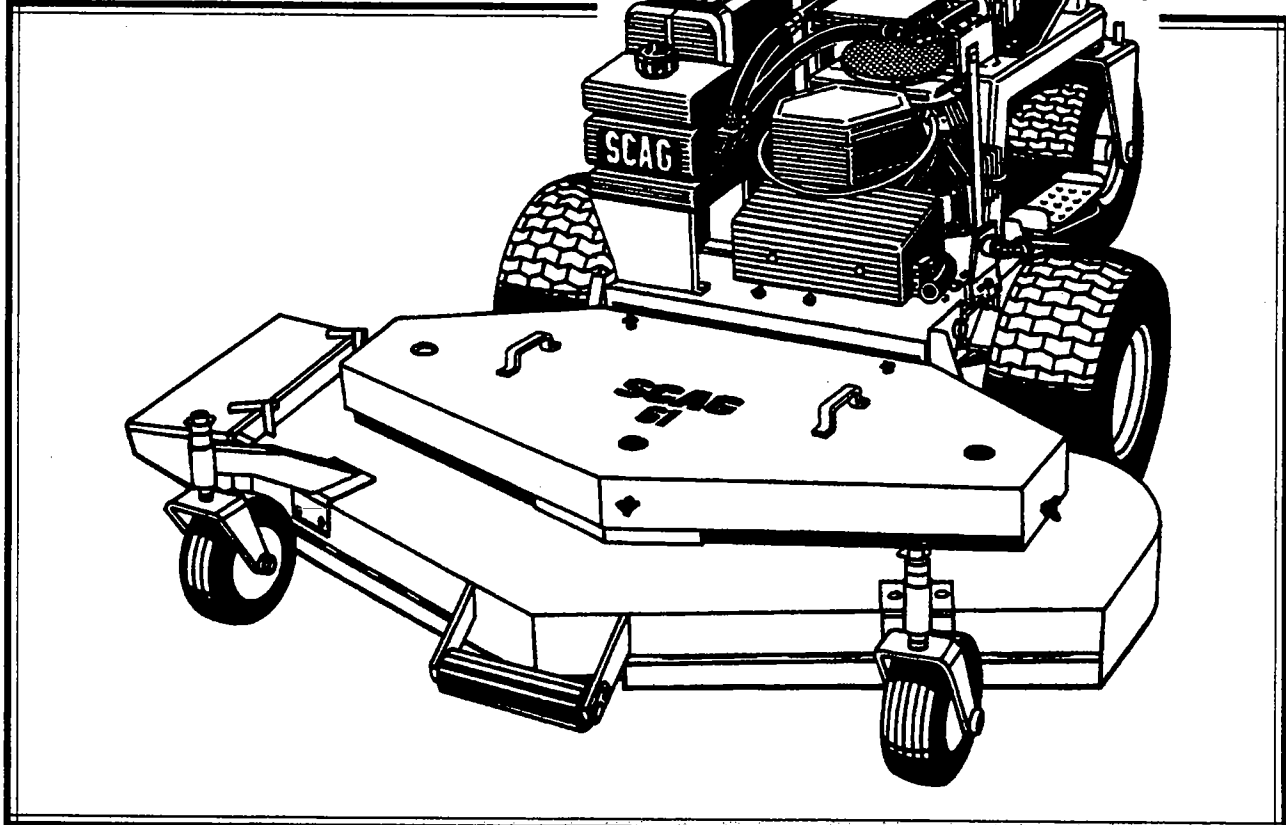

PART 03007

WARNING

If incorrectly used, this machine can cause severe injury. Those who use and maintain the machine should be trained in its proper use, warned of its dangers, and should read the entire manual before attempting to set up, operate, adjust or service the machine.

LIMITED WARRANTY-COMMERCIAL EQUIPMENT

Any part of the Scag commercial mower manufactured by Scag Power Equipment and found, in the reasonable judgment of Scag, to be defective in materials or workmanship, will be repaired or replaced by an Authorized Scag Service Dealer without charge for parts and labor. This warranty is limited to the original purchaser and is not transferable. Proof of purchase will be required by the dealer to substantiate any warranty claims. All warranty work must be performed by an Authorized Scag Service Dealer.

This warranty is limited to the following specified periods from the date of the original retail purchase for defects in materials or workmanship:

- * Wear items including drive belts, blades, hoses and tires are warranted for 90 days.
- * Batteries are covered for 90 days.
- * Frame, deck, and structural components including oil reservoir, fittings, and oil cooler are warranted for 1 year.
- * Engines and electric starters are covered by the manufacturer's warranty period.
- * Drive system components are warranted for 1 year by the component manufacturer, in conjunction with Scag Power Equipment. (Excluding fittings, hoses, cooling system, oil reservoir, drive belts).
- * Electric clutch components are warranted for 1 year.

Any Scag product used for rental purposes is covered by a 90 day warranty.

The Scag mower, including any defective part must be returned to an Authorized Scag Service Dealer within the warranty period. The expense of delivering the mower to the dealer for warranty work and the expense of returning it to the owner after repair will be paid for by the owner. Scag's responsibility is limited to making the required repairs and no claim of breach of warranty shall be cause for cancellation or rescission of the contract of sale of any Scag mower.

This warranty does not cover any mower that has been subject to misuse, neglect, negligence, or accident, or that has been operated in any way contrary to the operating instructions as specified in the Operator's Manual. The warranty does not apply to any damage to the mower that is the result of improper maintenance, or to any mower or parts that have not been assembled or installed as specified in the Operator's Manual and Assembly Manual. The warranty does not cover any mower that has been altered or modified changing performance or durability. In addition, the warranty does not extend to repairs made necessary by normal wear, or by the use of parts or accessories which, in the reasonable judgment of Scag, are either incompatible with the Scag mower or adversely affect its operation, performance or durability.

Scag Power Equipment reserves the right to change or improve the design of any mower without assuming any obligation to modify any mower previously manufactured.

All other implied warranties are limited in duration to the one (1) year warranty period or ninety (90) days for mowers used for rental purpose. Accordingly, any such implied warranties including merchantability, fitness for a particular purpose, or otherwise, are disclaimed in their entirety after the expiration of the appropriate one year or ninety day warranty period. Scag's obligation under this warranty is strictly and exclusively limited to the repair or replacement of defective parts and Scag does not assume or authorize anyone to assume for them any other obligation. Some states do not allow limitations on how long an implied warranty lasts, so the above limitation may not apply to you.

Scag assumes no responsibility for incidental, consequential or other damages including, but not limited to, expense for gasoline, expense of delivering the mower to an Authorized Scag Service Dealer and expense of returning it to the owner, mechanic's travel time, telephone or telegram charges, rental of a like product during the time warranty repairs are being performed, travel, loss or damage to personal property, loss of revenue, loss of use of the mower, loss of time or inconvenience. Some states do not allow the exclusion or limitation of incidental or consequential damages, so the above limitation or exclusion may not apply to you.

This warranty gives you specific legal rights, and you may also have other rights which vary from state to state.

SCAG[®]

POWER EQUIPMENT

TABLE OF CONTENTS

SUBJECT	PAGE
General Safety Instructions	
Equipment Safety.....	1-2
Operator Safety.....	2-3
Hydraulic Safety.....	3
Operation	
Initial Run-In.....	3
Before Starting.....	4
To Start Engine.....	4-5
Mower Operation.....	5-6
After Operation.....	6
Adjustments	
Tire Pressure.....	7
Parking Brakes.....	7
Neutral Adjustment.....	7-8
Belt Tension.....	8-9
Belt Alignment.....	9
Cutter Deck Adjustments.....	9-10
Maintenance	
Cutter Blades.....	11
Steering Cable Routing.....	11
Troubleshooting Cutting Conditions.....	12-14
Lubrication & Maintenance Chart.....	15

CONTINUED ON NEXT PAGE

TABLE OF CONTENTS

(CONTINUED)

SUBJECT	PAGE
Illustrated Parts List	
SM-52, SM-61 & SM-72 Cutter Decks.....	16-17
Engine Deck.....	18-19
Upper Hydraulics.....	20-21
Lower Hydraulics.....	22-23
Control Linkage.....	24-25
Instrument Panel & Electrical Components.....	26-27
Rider Frame Assembly.....	28-29
Brake Linkage.....	30-31
Electrical System Wiring Diagram.....	32
Winch Lift System.....	33
Replacement Decals & Information.....	34
Warranty Statment	Inside Back Cover

Your mower was built to the highest standards in the industry. However, your mower is only as safe as the operator. Carelessness or operator error may result in serious bodily injury or death. Hazard control and accident prevention are dependent upon the awareness, concern, prudence, and proper training of the personnel involved in the operation, transport, maintenance, and storage of the equipment. Make sure every operator is properly trained and thoroughly familiar with all the controls before operating the equipment.

- Scag Power Equipment -

GENERAL SAFETY INSTRUCTIONS

- **READ THIS OPERATOR'S MANUAL BEFORE ATTEMPTING TO START YOUR MACHINE** and read the instructions furnished with attachments.
- A replacement manual is available from your authorized Scag Service Dealer or by contacting Scag Power Equipment, Service Department at P.O. Box 152, Mayville, WI 53050. There is a nominal charge of \$2.00 for each manual. Please indicate the complete model number and serial number of your Scag Product.
- Perform only those maintenance instructions described in this manual. If major repairs are ever needed or assistance is desired, contact an authorized Scag dealer. To ensure optimum performance and safety, always purchase genuine Scag replacement parts and accessories. **NEVER** use "WILL FIT" replacement parts and accessories made by another manufacturer. **THE USE OF UNAPPROVED REPLACEMENT PARTS OR ACCESSORIES COULD VOID THE WARRANTY.**

EQUIPMENT SAFETY

- Know the controls and how to stop quickly.
- Clear the work area of objects (wires, rocks, etc.) that might be picked up and thrown.
- Disengage power to the attachments when transporting or not in use.
- **DO NOT** change the engine governor settings or overspeed the engine.
- Take all possible precautions when leaving the machine unattended, such as disengaging the power-take-off, lowering the attachments, setting the parking brake, stopping the engine, and removing the key.
- Keep the machine and attachments in good operating condition, and keep safety devices and shields in place and in good working condition.
- Keep all nuts, bolts, and screws tight to be sure the equipment is in a safe working condition.
- **NEVER** store the equipment with gasoline in the tank inside a building where fumes may reach an open flame or spark. Allow the engine to cool before storing in any enclosure.
- The machine and attachments should be stopped and inspected for damage after striking a foreign object, and the damage should be repaired before restarting and operating the equipment.
- Under normal usage, the grass catcher bag material is subject to deterioration and wear. Check bag frequently and replace worn bags. Check that the replacement bags comply with the original manufacturer's recommendations and/or specifications.

EQUIPMENT SAFETY- cont'd

- The discharge chute **must** be installed and in the down position on the side discharge mower except when the optional grass catcher or mulch kit is completely installed. If the mower discharge ever plugs, shut the engine off and wait for all movement to stop before removing obstruction.
- Clean grass, leaves, and lubricant spills from the surfaces of your machine after use to prevent spontaneous combustion.

OPERATOR SAFETY

- **NEVER** operate the machine without approved ventilation. Exhaust fumes are dangerous. **DO NOT** run the engine indoors.
 - **DO NOT** allow children to operate the machine. Do not allow adults to operate it without proper instruction.
 - **DO NOT** carry passengers. Do not mow when children and others are present. When using any attachments, never direct the discharge of material toward bystanders nor allow anyone near the machine while in operation.
 - Before attempting to start the engine, disengage power to all attachments and engage parking brake. **DO NOT** depress the right foot pedal.
 - **BEFORE** leaving the operator's position, disengage power to the attachments and engage the parking brake.
 - Before making any repairs or adjustments, disengage power to the attachments. **STOP THE ENGINE AND REMOVE KEY.**
 - **DO NOT** operate machine while wearing sandals, tennis shoes, sneakers or shorts. Always wear long pants and substantial shoes. **NEVER** wear loose fitting clothing which could get caught in moving parts. Wearing safety glasses and safety shoes is advisable and required by some local ordinances and insurance regulations.
- Wearing hearing protection is recommended during the operation of the machine.
 - Do not stop or start suddenly. **WHEN GOING UPHILL OR DOWNHILL, MOW UP AND DOWN THE FACE OF STEEP SLOPES, NEVER ACROSS THE FACE.**
 - Reduce speed and exercise extreme caution on slopes and in sharp turns to prevent tipping or loss of control. Be especially cautious when changing direction on slopes.
 - Stay alert for holes, rocks, and roots in the terrain and other hidden hazards. Keep away from drop-offs.
 - Disengage power to the mower before backing up. Do not mow in reverse unless absolutely necessary and then only after observation of the entire area behind the mower.
 - **DO NOT** turn sharply. Use care when backing up.
 - Use counterweights or wheel weights when suggested in this operator's manual.
 - Watch out for traffic when crossing roads or operating near roadways.
 - Handle gasoline with care - it is highly flammable.
 - Use approved gasoline container. Never remove the fuel cap or add gasoline to a running or hot engine or an engine that has not been allowed to cool for several minutes after running. Never fill the tank indoors and always clean up spilled gas.
 - When using the machine with mower attached, proceed as follows:
 1. Mow only in daylight or in good artificial light.
 2. Never make a cutting height adjustment while the engine is running.

CONTINUED

OPERATOR SAFETY - cont,d

3. Shut the engine off and remove the key when removing the grass catcher or unclogging the chute.
4. Check the blade mounting bolts for proper tightness at frequent intervals.



WARNING:

DO NOT operate on steep slopes. To check a slope, attempt to drive up it (with cutter deck down). If machine can drive up the slope without the wheels slipping, reduce speed and use extreme caution. ALWAYS FOLLOW OSHA APPROVED OPERATION.

HYDRAULIC SAFETY

- Keep body and hands away from pin holes or nozzles that eject hydraulic fluid under high pressure. Use paper or cardboard and not hands to search for leaks.
- Hydraulic fluid escaping under high pressure may have sufficient force to penetrate skin and cause serious injury. If foreign fluid is injected into the skin, it must be surgically removed within a few hours by a doctor familiar with this form of injury or gangrene may result.
- Make sure all hydraulic fluid connections are tight and all hydraulic hoses and lines are in good condition before starting the machine.
- Hydraulic fluid is under high pressure. If you need service on your hydraulic system, please see your authorized Scag dealer.

INITIAL RUN-IN

First Day of Use or approximately 10 hours.

- Check belts for proper tension at 2, 4 and 8 hours; adjust as needed.
- Check neutral adjustment. Adjust if necessary, (*see Adjustments on page 7*) so that mower does not move in neutral.
- Check the tires for proper pressure (*see Adjustments on page 7*).
- Check for loose hardware. Tighten as needed.
- Allow belts to run-in for 5 minutes. While engine is running, check safety switches for proper adjustments.
- Engine should quit under these conditions:
 1. With disengaged parking brake, lift left foot.
 2. With engaged blades, lift left foot.
- Engine should NOT quit if blades are off and parking brake is engaged.
- Engine should crank and start if parking brake is on and PTO engagement switch is off.
- ENGINE Should NOT crank if PTO engagement switch is on and/or parking brake is disengaged.
- Grease machine fittings:
 - 2 caster arms
 - 2 caster wheels
 - 3 spindles
 - 2 deck idler pivot arms
 - 1 engine idler pivot
 - 1 foot control linkage (under engine deck)
 - 2 yokes (left and right sides)
 - 1 control foot pedal
 - 1 steering shaft
 - 1 rear wheel yoke shaft
 - 1 rear wheel bearing

BEFORE STARTING

- Check belts for:
 1. Proper tension
 2. Fraying and wear
 3. Twisting
 4. Cracking
- Check initial tension of cutter blade drive belts. If belts are not tensioned, see Adjustments, page 8.
- Check oil levels in engine and hydraulic reservoir.
- Fill tank with clean fresh lead-free gasoline.

-Note-

For best engine performance, SCAG recommends using gasoline with an octane rating no less than 89.

TO START ENGINE

1. Pull parking brake to **ENGAGE** position.
2. Pull mower PTO engagement switch down (**OFF** position) to disengage mower.
3. Depress the left operator presence pedal.

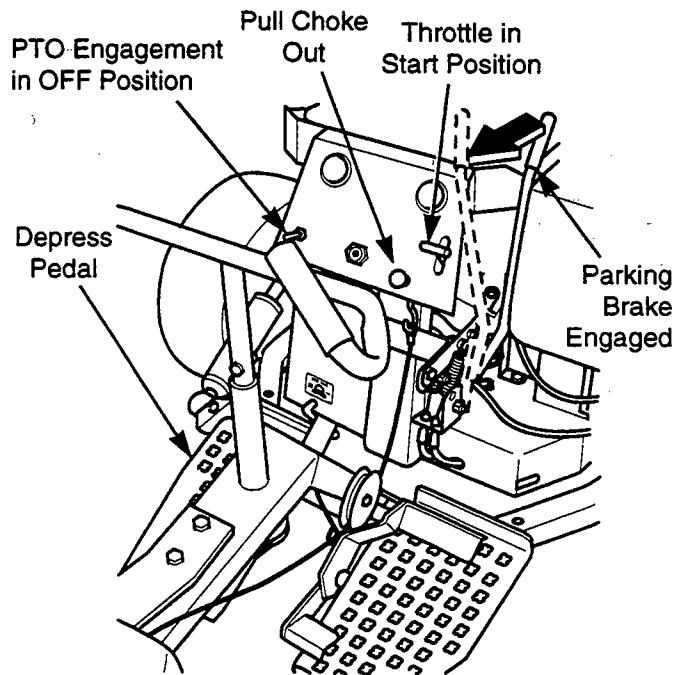

Starting Engine

4. Adjust throttle to **START** position.
5. Pull choke out. (Engine has a fuel solenoid shutoff that may require choking engine for each start.)



WARNING:
DO NOT depress right hydro-foot pedal when starting engine.

TO START ENGINE-cont,d

6. Start engine. Adjust choke as needed.
7. To engage blades, release the parking brake. Observe to see that the unit does not creep forward or backward. If it does creep, adjust hydro-neutral control (*see Adjustments, page 7*).
8. Release the parking brake. Push mower PTO engagement switch up to engage the cutter deck.

MOWER OPERATION

-Note-

If you are not familiar with the operation of the hydrostatic drive, practice turning and maneuvering with the foot controls before engaging the blades.

-Note-

When PTO is engaged or (possibly) disengaged, squealing sound from the underside is normal. It is caused by the electric clutch plates meshing as the mower comes up to speed. For best equipment life, engage clutch with engine idled down, not under load.

1. To operate the unit, depress the right foot pedal at the toe end to make the machine drive forward or depress the right foot pedal at the heel end to make the machine drive in reverse. Check that all systems function correctly.

-Note-

The left operator presence pedal must be depressed before operation.

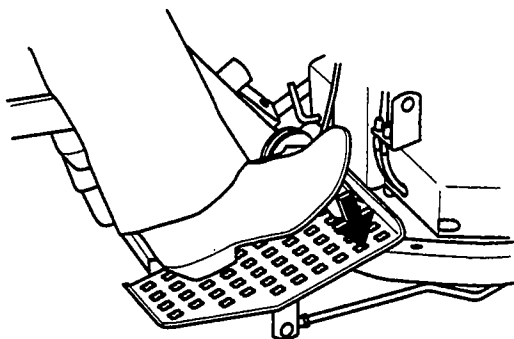

Forward Operation - Depress Toe End of Pedal

MOWER OPERATION- cont,d

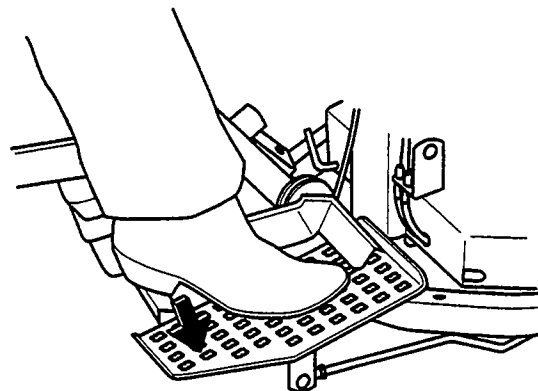

Backward (Reverse) Operation - Depress Heel End of Pedal

2. Reduce drive speed when turning around trees, shrubs, etc.



CAUTION:

Avoid high-speed turns on all surfaces. Tires can slip on grass and wear rapidly on concrete and asphalt.

3. When going over curbs, first turn winch cable under seat to raise cutter deck to clear curb. Go **FORWARD** over curb. Always leave slack in winch cable after lowering deck.

MOWER OPERATION- cont,d



WARNING:

Reduce speed and be very careful when operating on slopes to prevent tipping. If you need to turn on a hill, always turn downhill.

4. When operating on a slope, travel up or down the grade, whenever possible, never across the grade.

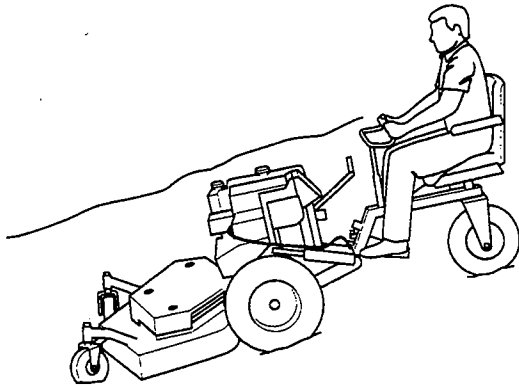

Proper Operation on Slope

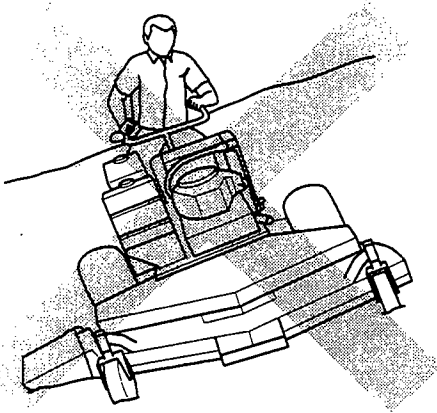

Improper Operation on Slope

AFTER OPERATION

1. Shut off engine.
2. Recheck the cutter drive belts for proper tension, alignment, and any signs of rubbing. Correct and adjust as necessary.

To "freewheel" or move the machine around without the engine running, rotate the dump valve lever located on the left rear of engine deck to **FREEWHEEL** position (*see figure below*). The Lever must be returned to the original position to operate machine. Disengage the parking brake.

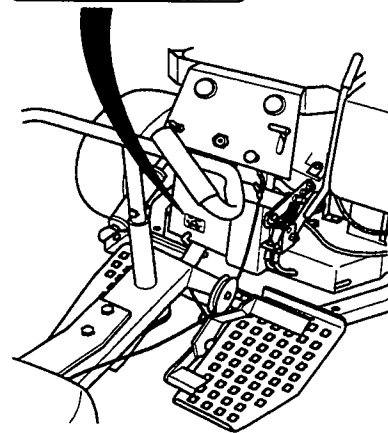
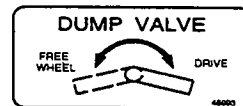

Freewheel Control

ADJUSTMENTS

MAINTAIN TIRE PRESSURES

Caster Wheels	25 PSI
Rear Steering Wheel	15 PSI
Drive Wheels	15 PSI

PARKING BRAKE

Minor brake adjustments can be made by loosening the top nut on both brake cables (See figure below). Back the nuts off approximately 1/4". While pulling one cable downward, tighten the bottom nut on the cable until it touches the bottom of the brake cable mount. Tighten both the top and bottom nuts to lock the cable in place. Repeat the above steps for the second brake cable. Make sure that both cables are adjusted evenly so that the brakes do not cause the mower to pull to the left or right.

-Note-

This is a minor brake adjustment. If the brakes do not function properly after this adjustment, see your Scag Service dealer before operating your mower.

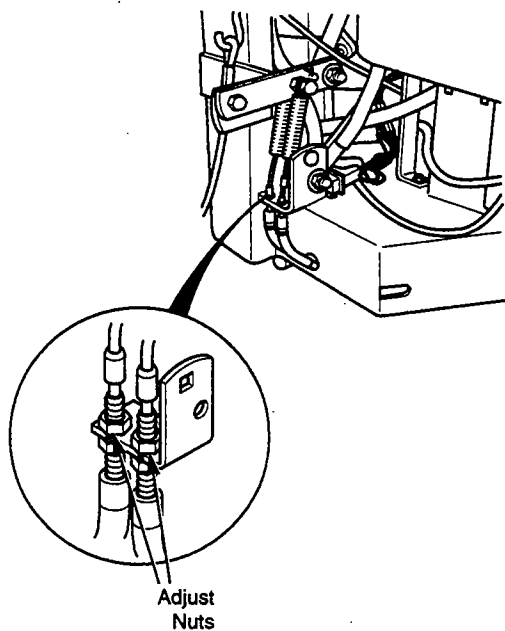

Parking Brake Adjustment

NEUTRAL ADJUSTMENT

1. Set the engine deck up on jack stands so the wheels are free to rotate.
2. Block the caster wheels to prevent an accident should the unit fall off the jack stands.
3. Start the engine and determine if the drive wheels rotate.

If the drive wheels consistently rotate when foot pedal control is in neutral, go to step 4.

If the drive wheels inconsistently rotate, i.e. drive wheels sometimes rotate and sometimes do not when foot pedal is not depressed, then check neutral adjustment bolt for "zero free play" in neutral control spring.

-Note-

***DO NOT OVERTIGHTEN.** If you turn the nut too much you will compress the spring, making too much end play. Go to step 4.*

4. If drive wheels rotate in rearward travel direction, turn adjustment bolt clockwise until rotation stops. If drive wheels rotate in backward travel direction, turn adjustment bolt counter-clockwise until rotation stops (see figure below).

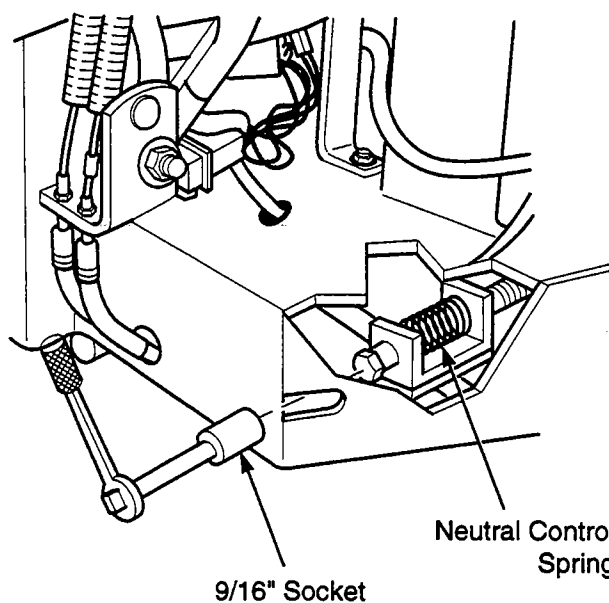

9/16" Socket

Neutral Control Spring

Neutral Adjustment

ADJUSTMENTS (cont'd)

5. Check the adjustment of the right foot control pedal for full forward speed. The pedal should rest on the foot plate when the pump is stroked in the full forward position. To make an adjustment, disconnect the ball joint from the pedal arm and loosen the jam nut (See figure below). Place the foot control pedal forward against the foot rest and adjust the ball joint on the rod until the stud aligns with the hole in the arm. Bolt ball joint to the arm and tighten the jam nut.

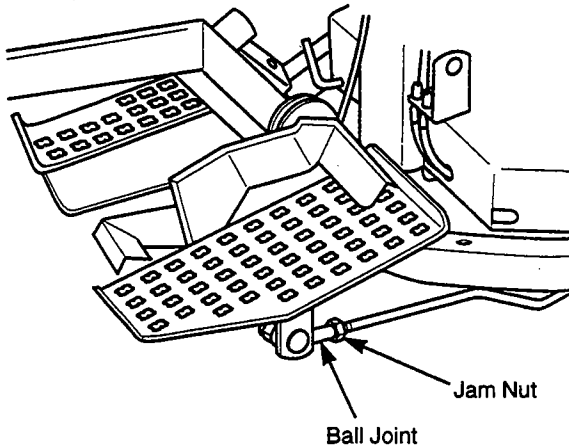

Foot Control Pedal Adjustment

6. Start the engine. The wheels should rotate only when the foot control pedal is depressed.

BELT TENSION



CAUTION:

Stop engine and remove key from ignition before making any adjustments. Wait for all moving parts to come to a complete stop before beginning work.

-Note-

The Hydro Drive Belt is spring-loaded and does not require adjustment.

To Adjust Cutter Deck Drive and Blade Belts:

1. Remove belt cover.
2. To adjust cutter deck drive belt, adjust the nut so that the belt moves 1/2" with 10 pounds of pressure. (See figure below)

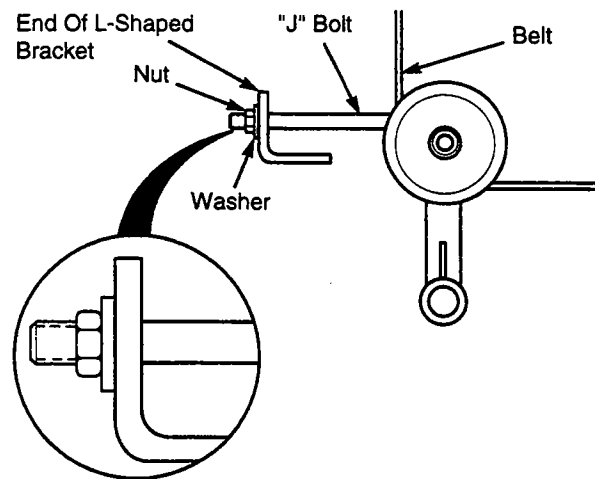

**Cutter Deck Drive Belt Tension Alignment-
Idler - L.H.**

ADJUSTMENTS (cont'd)

- To adjust blade drive belt: Using a belt tension gauge, check the belt tension so that the belt moves 1/2" with

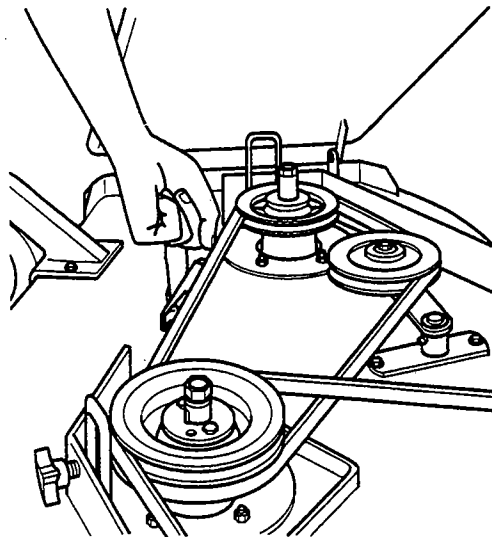

Blade Drive Belt Tension Check

Adjust the tension by tightening or loosening the J-bolt.

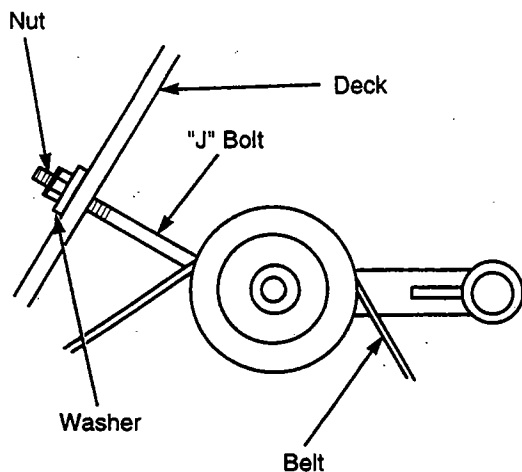

Belt Tension Adjustment - Idler, R.H.

- Replace the belt covers.

BELT ALIGNMENT

Belt alignment is important to proper performance of your Scag mower. If you experience frequent belt wear or breakage, see your authorized Scag Service Dealer for belt adjustment.

CUTTER DECK ADJUSTMENTS

Due to the many conditions that exist, it is difficult to suggest a setting that will work for every lawn. There are, however, two adjustments that should be made on the cutter deck: pitch and height.

PITCH is the angle of the blades (comparing front to rear).

HEIGHT is the nominal distance that the blade is off the ground. This measurement is made with the blades pointed side to side and distance is measured between cutting tip and ground.

Adjusting the blade height can be done by moving any number of the four smaller spacers on the blade mounting bolts to the top of the spindle shaft or below the spindle shaft. All blades should be positioned equally (*see Spindle Illustration, p. 10*).

ADJUSTMENTS (cont'd)

The unit is shipped with one spacer on top of spindle and four underneath (see figure below). This adjustment does not affect blade pitch.

There are three positions for mounting the cutter deck (see figure below). For cutting in the lowest position, mount the cutter deck in the top hole (A). For cutting in the highest position, mount the deck in the lowest hole (C). Setting the cutter deck height will be determined by the type of cutting conditions.

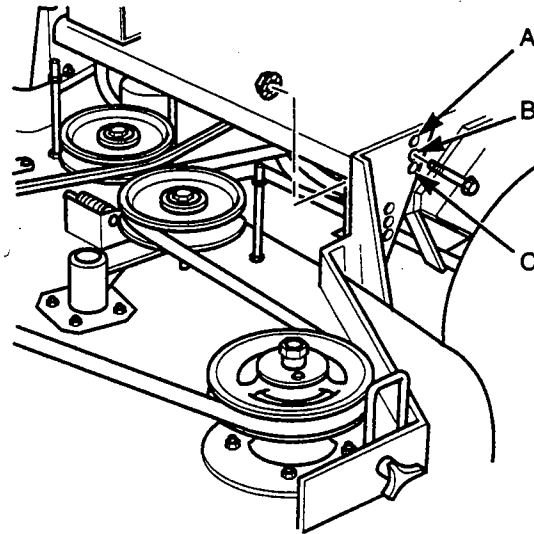
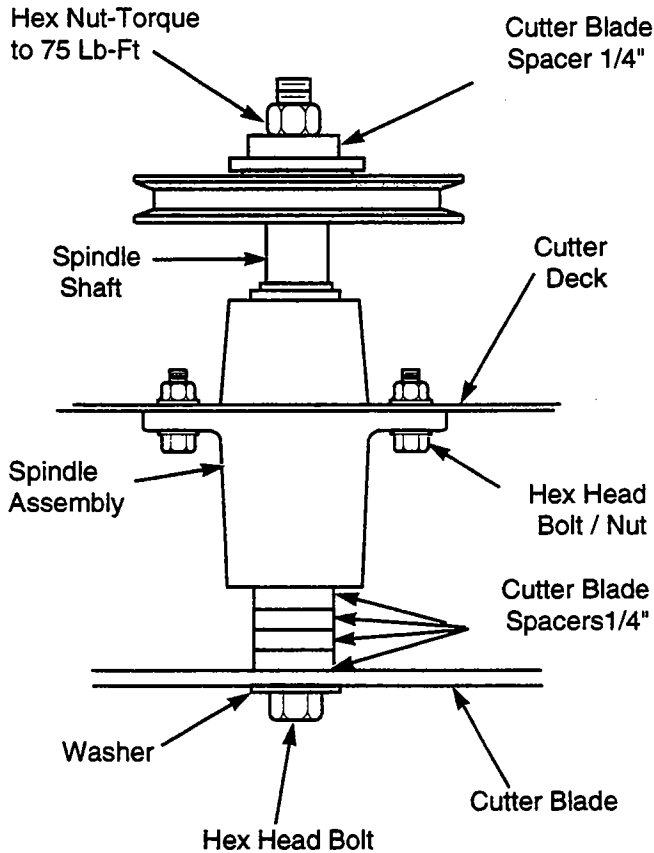

Cutter Deck Height Adjustment

Caster spacers also can be repositioned to change the cutting heights and to change the pitch of the deck (see figure below).

To adjust the caster spacers, raise the deck and remove the pin and caster wheel. Reposition the caster spacers as needed, then replace the caster, top spacers and pin. Make the same adjustments on the other caster wheel.

To adjust the blade height move any number of the five smaller spacers on the blade mounting bolts to the top of the spindle shaft or below the spindle shaft.

-Note-

For best results, keep the cutter deck high in relation to the engine deck and the blades low in the cutter deck; ie. 4 or 5 spacers below the spindle shaft.

Additional range to the cutting height can be achieved by repositioning the cutter deck in relationship to the engine deck. This adjustment also affects the pitch of the deck.

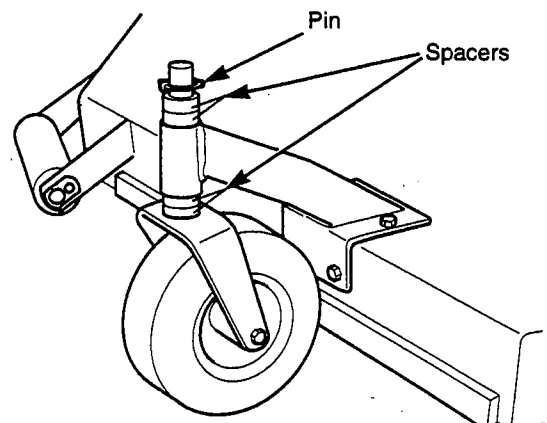

Repositioning Spacers

MAINTENANCE

CUTTER BLADES

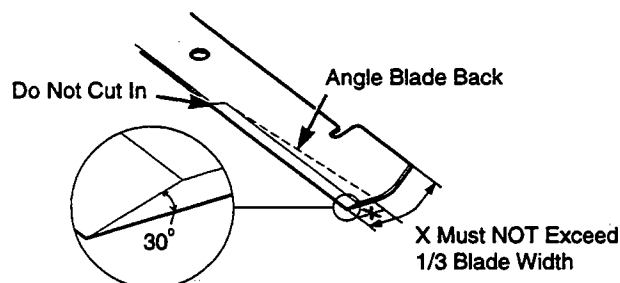

Do not sharpen beyond 1/3 of the width of the blade.

Suggestion: Dress the blade with a file. Using a wheel grinder may burn the blade. Check the balance of the blade. If blades are out of balance, vibration and premature wear can occur. See your authorized Scag dealer for blade balance tools.

STEERING CABLE ROUTING

When the steering cable is routed between the front pulley and the rear steering collar, it is very important that the cable does not rub where it crosses. The top of the cable end from the front pulley must go over the top of the lower cable end (See figure below). The cable should be tightened until the slackness has been removed. The cable should **not** be under tension. Do not overtighten the adjusting nuts on the rear steering collar pulley.

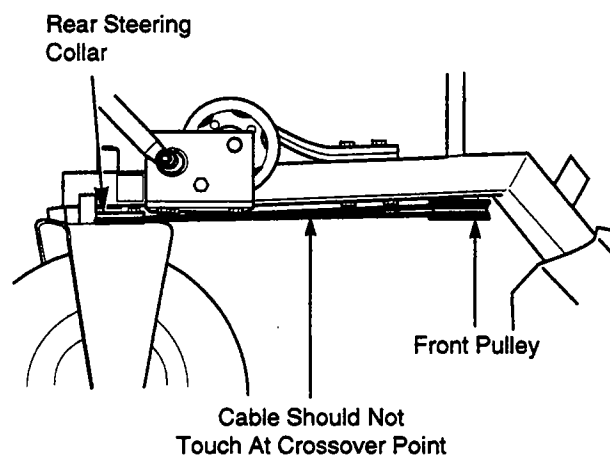

TROUBLESHOOTING

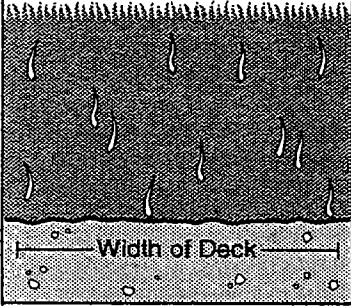
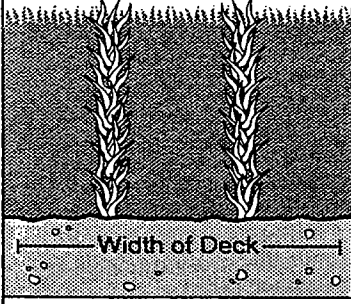
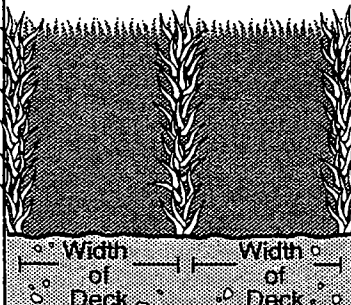
CONDITION	CAUSE	CURE
Stringers - Occasional Blades of Uncut Grass 	Low engine RPM	Run engine at full 3600 RPM
	Ground speed too fast	Slow speed to adjust for conditions
	Wet grass	Cut grass after it has dried out
	Dull blades, incorrect sharpening	Sharpen blades
	Deck plugged, grass accumulation	Clean underside of deck
	Belts slipping	Adjust belt tensions
Streaking - Strips of Uncut Grass in Cutting Path 	Dull, worn blades	Sharpen blades
	Incorrect blade sharpening	Sharpen blades
	Low engine RPM	Run engine at full 3600 RPM
	Belt slipping	Adjust belt tension
	Deck plugged, grass accumulation	Clean underside of deck
	Ground speed too fast	Slow speed to adjust for conditions
	Wet grass	Cut grass after it has dried out
Bent blades	Replace blades	
Streaking - Strips of Uncut Grass Between Cutting Paths 	Not enough overlapping between rows	Increase the overlap of each pass

TROUBLESHOOTING

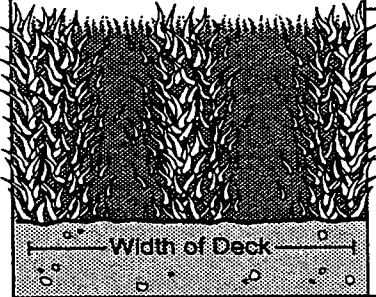
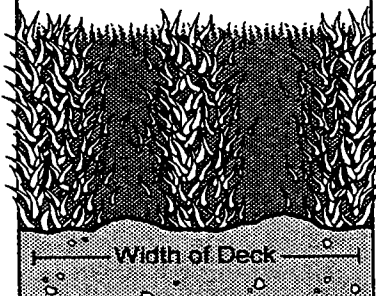
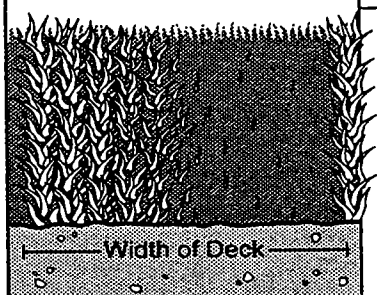
CONDITION	CAUSE	CURE
Uneven Cut on Flat Ground - Wavy High-Low Appearance, Scalloped Cut or Rough Contour 	Lift worn off of blade	Replace blade
	Blade upside down	Mount with cutting edge toward ground
	Deck plugged, grass accumulation	Clean underside of deck
	Too much blade angle (deck pitch)	Adjust pitch and level
	Deck mounted improperly	See your authorized SCAG dealer
	Bent spindle area	See your authorized SCAG dealer
	Dull Blade	Sharpen Blade
Uneven Cut on Uneven Ground - Wavy Appearance, High-Low Scalloped Cut or Rough Contour 	Uneven ground	May need to reduce ground speed, raise cutting height, and/or change direction of cut
Sloping Ridge Across Width of Cutting Path 	Tire pressures not equal	Check and adjust tire pressure
	Wheels uneven	Check and adjust tire pressure
	Deck mounted incorrectly	See your authorized SCAG dealer

TROUBLESHOOTING

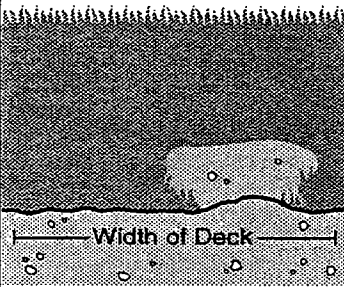
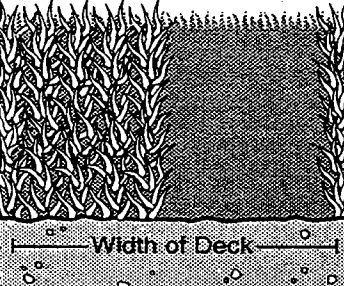
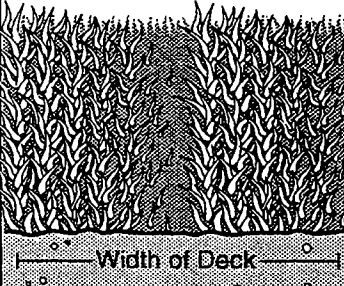
CONDITION	CAUSE	CURE
Scalping - Blades Hitting Dirt or Cutting Very Close to the Ground 	Low tire pressures	Check and adjust pressures
	Ground speed too fast	Slow speed to adjust for conditions
	Cutting too low	May need to reduce ground speed, raise cutting height, change direction of cut and/or change pitch and level
	Rough terrain	May need to reduce ground speed, raise cutting height, and/or change direction of cut
	Ground speed too fast	Slow speed to adjust for conditions
	Wet grass	Cut grass after it has dried out
Step Cut - Step Cut Ridge in Center of Cutting Path 	Blades not mounted evenly Bent blade	Adjust pitch and level Replace blade
	Internal spindle failure	See your authorized SCAG dealer
	Mounting of spindle incorrect	See your authorized SCAG dealer
Slope Cut - Sloping Ridges Across Width of Cutting Path 	Bent spindle mounting area	See your authorized SCAG dealer
	Internal spindle failure	See your authorized SCAG dealer
	Bent deck housing	See your authorized SCAG dealer

LUBRICATION & MAINTENANCE

- * Lubrication may be required every 8 to 40 hours, depending on climate and environment.
- * Do not over-grease as this may damage seal.
- + Compatible Greases: Mobilux #2 found at Mobil Service Stations
 Ronex MP found at Exxon Service Stations
 Super Lube MEP #2 & Super Stay-M #2 found at Conoco Service Stations
 Shell Alvania #2 found at Shell Service Stations
 Lidok EP #2 found at industrial shops

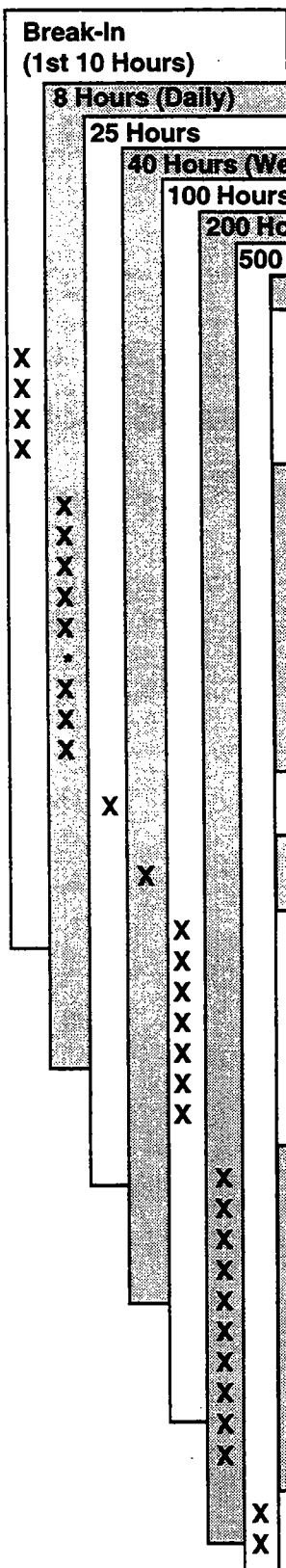

PROCEDURE	COMMENTS
Check all hardware for proper tightness Change engine oil and filter at 5 hours Check hydrostatic oil level Check belt tightness	Add oil as needed - SAE 10W30
Fill fuel tank before starting Check engine oil Clean blower screen Remove debris from under belt cover Sharpen cutter blades Grease spindle bearings 2 pumps of hand gun Clean air filter/check for damages or loose parts Check/clean air intake and cooling areas ¹ Check tire pressure	Do not over fill MORE OFTEN IF NEEDED + US Lithium MP White Grease 2125 MORE OFTEN IF NEEDED MORE OFTEN IF NEEDED Add or adjust as required
Service precleaner element ¹	
Check battery acid level	Distilled water only
Grease caster wheel bearings Grease caster wheel pivots Grease idler arm pivots Service air cleaner element ¹ Change engine oil Check spark plug condition and gap Clean cooling areas ¹	Chassis grease Chassis grease Chassis grease See engine mfg. information See engine mfg. information
Check all hardware for proper tightness Change engine oil filter Check hydro fluid reservoir level Clean and adjust spark plugs Grease rider frame pivot Grease control bell cranks Grease steering handle bearing Grease foot pedal bearings Grease rear wheel pivot vertical Grease rear wheel bearing	See engine mfg. information See engine mfg. information Chassis Grease Chassis Grease Chassis Grease Chassis Grease Chassis Grease Chassis Grease + US Lithium MP White Grease 2125
Drain hydraulic system and replace fluid Change hydrostatic oil filter	Use SAE 10W30 motor oil Clean area before removing filter

1. Perform these maintenance procedures more frequently under extreme dusty or dirty conditions.

SM-52, SM-61 & SM-72 CUTTER DECK

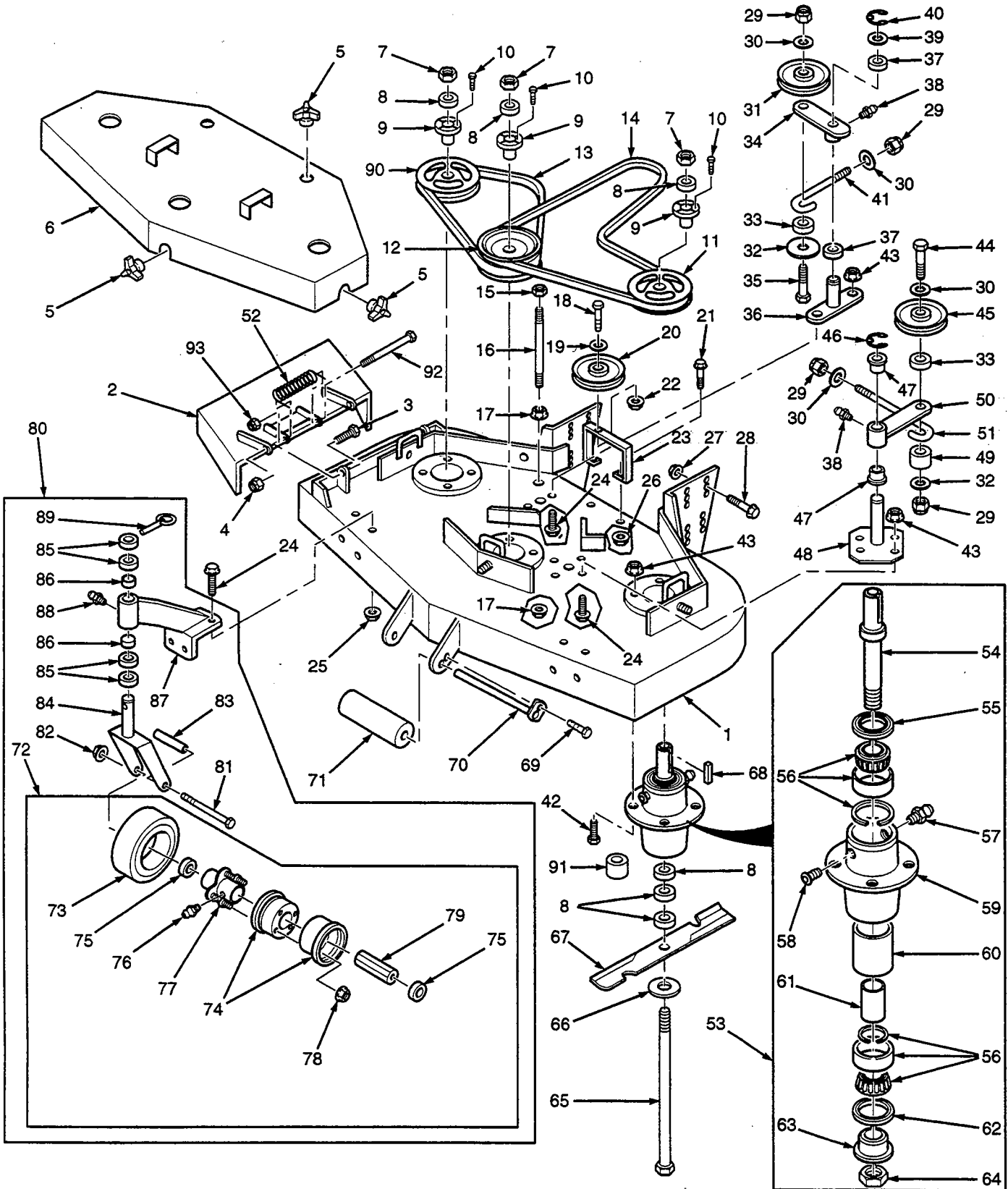

SM-52, SM-61, SM-72 CUTTER DECK

Ref. No.	Part Number	Description	SM			Ref. No.	Part Number	Description	SM		
			52	61	72				52	61	72
1	45594	Cutter Deck (Includes decals)	X			49	43277	Spacer	X	X	X
	45595	Cutter Deck (Includes Decals)		X		50	46593	Idler Arm (Includes 38 & 47)	X	X	X
	46620	Cutter Deck (Includes Decals)			X	51	44078	J-Rod, Drive Idler	X	X	X
2	46725	Discharge Chute	X			52	481050	Spring, Chute Return	X	X	X
	45612	Discharge Chute		X	X	53	46631	Spindle Assembly	X	X	X
3	*	Bolt, Hex Head 5/16-18 x 1	X	X	X	54	43298	Shaft, Cutter Spindle	X	X	X
4	*	Hex Nut, Elastic Stop 5/16-18	X	X	X	55	481024	Seal, 2.00 OD x 1.50 Bore	X	X	X
5	04029-03	Wing Nut, 3/8-16 x 7/8	X	X	X	56	481022	Bearing Assembly	X	X	X
6	46731	Belt Cover (Includes Decals)	X			57	48114-02	Grease Fitting, Str. 5/16	X	X	X
	46732	Belt Cover (Includes Decals)		X		58	48677	Relief Fitting, Cutter Spindle	X	X	X
	46609	Belt Cover (Includes Decals)			X	59	43294	Spindle Housing	X	X	X
7	04020-09	Hex Nut 5/8-11	X	X	X	60	43295	Spacer, Outside	X	X	X
8	43278	Spacer, Cutter Blade	X	X	X	61	43296	Spacer, Inside	X	X	X
9	48926	Tapered Hub, 1.125 Bore	X	X	X	62	481025	Seal, 2.00 OD x 1-5/8 Bore	X	X	X
10	04001-01	Bolt, Hex Hd. 1/4-20 x 3/4	X	X	X	63	43297	Spindle Bushing, Bottom	X	X	X
11	48924	Pulley 5.75 OD	X			64	481035	Nut, 1-1/16-18 UNEF-2B	X	X	X
	48753	Pulley 6.35 OD		X		65	04001-41	Bolt, Hex Head 5/8-11 x 9-1/2	X	X	X
	48967	Pulley 6.95 OD			X	66	04040-10	Flatwasher 5/8	X	X	X
12	48923	Pulley, Double Groove 5.75 OD	X			67	48108	Cutter Blade, 18" Standard	X		
	48940	Pulley, Double Grov. 6.35/5.75 OD		X			48185	Cutter Blade, 18" Hi Lift	X		
	48966	Pulley, Double Grov. 6.95/5.75			X		48111	Cutter Blade, 21" Standard		X	
13	48285	Belt, R.H. Blade Drive	X				48304	Cutter Blade, 21" Hi Lift		X	
	48265	Belt, R.H. Blade Drive		X			48112	Cutter Blade, 24" Standard			X
	48295	Belt, R.H. Blade Drive			X	68	04063-08	Key, 1/4 x 1/4 x 2	X	X	X
14	48530	Belt, Deck Drive	X			69	04017-15	Serr. Fl. HH Cap, 5/16-18 x 1/2	X	X	X
	48912	Belt, Deck Drive		X		70	45046	Shaft, Roller	X	X	X
	481001	Belt, Deck Drive			X	71	48038	Guide, Roller	X	X	X
15	*	Hex Locknut 3/8-16	X	X	X	72	48307-01	Wheel Assy., Caster	X	X	X
16	04004-14	Stud, 3/8-16 x 63/4	X	X	X	73	48307-02	Tire Only, Caster Wheel	X	X	X
17	04019-04	Serr. Fl. Hex Nut, 3/8-16	X	X	X		48006-03	Inner Tube Only, Caster Whl	X	X	X
18	*	Bolt, Hex Head 3/8-16 x 2 1/4		X	X	74	48307-04	Rim Pair, Caster Wheel	X	X	X
19	*	Flatwasher		X	X	75	48006-07	Retainer, Caster Wheel	X	X	X
20	48269	Pulley, Belt Guide		X	X	76	48114-03	Grease Fitting, 45 Deg. 1/4-28	X	X	X
21	04017-16	Serr. Fl. HH Cap., 5/16-18 x 3/4		X	X	77	48006-05	Hub Assy. W/Bolts, Caster Whl	X	X	X
22	*	Hex Nut, Elastic Stop 3/8-16		X	X	78	48307-08	Tapered Hex Nut, 5/16-18	X	X	X
23	421355	Idler Pulley Support		X	X	79	48006-06	Roller Bearing, Caster Whl.	X	X	X
24	04017-16	Serr. Fl HH CPSR, 5/16-18 x 3/4	X	X	X	80	46079	Caster Wheel Assembly	X	X	X
25	04019-03	Serr. Fl. Hex Nut, 5/16-18	X	X	X	81	*	Bolt, Hex Head 1/2-13 x 5-1/2	X	X	X
26	04019-03	Serr. Fl. Hex Nut, 5/16-18		X	X	82	*	Hex Nut, Elastic Stop 1/2-13	X	X	X
27	04019-06	Serr. Fl. Hex Nut, 1/2-13	X	X	X	83	43022	Sleeve, Caster Whl. Bearing	X	X	X
28	04017-37	Serr. Fl. HH Cap., 1/2-13 x 1-1/4	X	X	X	84	45006	Caster Yoke	X	X	X
29	*	Nut, HH Elastic Stop 3/8-16	X	X	X	85	43037001	Spacer, Caster Yoke 1/2"	X	X	X
30	*	Flatwasher 3/8	X	X	X	86	43037-01	Bronze Bearing	X	X	X
31	48181	Pulley	X	X	X	87	46082	Support Assy. (Includes 88-90)	X	X	X
32	*	Flatwasher	X	X	X	88	48114-04	Grease Fitting, Str. 1/4-28	X	X	X
33	43077	Spacer	X	X	X	89	04066-01	Quick Pin	X	X	X
34	46081	Idler Arm (Includes 37 & 38)	X	X	X	90	48924	Pulley, 5.75	X	X	X
35	*	Bolt, Hex Head 3/8-16 x 2-1/4	X	X	X	91	43279	Spacer, Cutter Blade	X	X	X
36	45037	Idler Pivot	X	X	X	92	04001-108	Bolt, Hex Head 5/16-18 x 1-1/4	X	X	X
37	48100-05	Bearing, Bronze Oilite	X	X	X	93	04021-10	Locknut, Elastic Stop 5/16-18	X	X	X
38	48114-04	Grease Ftg., Str 1/4-28 Self Tap	X	X	X						
39	04041-08	Flatwasher, 1-1/4 x .059 Thick	X	X	X						
	04041-08S	Flatwasher, 1-1/4 x .035 Thick	X	X	X						
40	*	Retaining Ring	X	X	X						
41	43028	J-Rod, Idler Pulley	X	X	X						
42	04001-10	Bolt, Hex Head 5/16-18 x 1-1/4	X	X	X						
43	04019-03	Serr. Fl. Hex Nut, 5/16-18	X	X	X						
44	*	Bolt, Hex Head 3/8-16 x 3-1/2	X	X	X						
45	48269	Pulley, Deck Drive Idler	X	X	X						
46	*	Retaining Ring	X	X	X						
47	48100-02	Bearing, Bronze Oilite	X	X	X						
48	45329	Idler Pivot Support	X	X	X						

* Common Hardware which should be purchased locally. All Bolts Grade 5 plated. All other fasteners are zinc plated.

ENGINE DECK

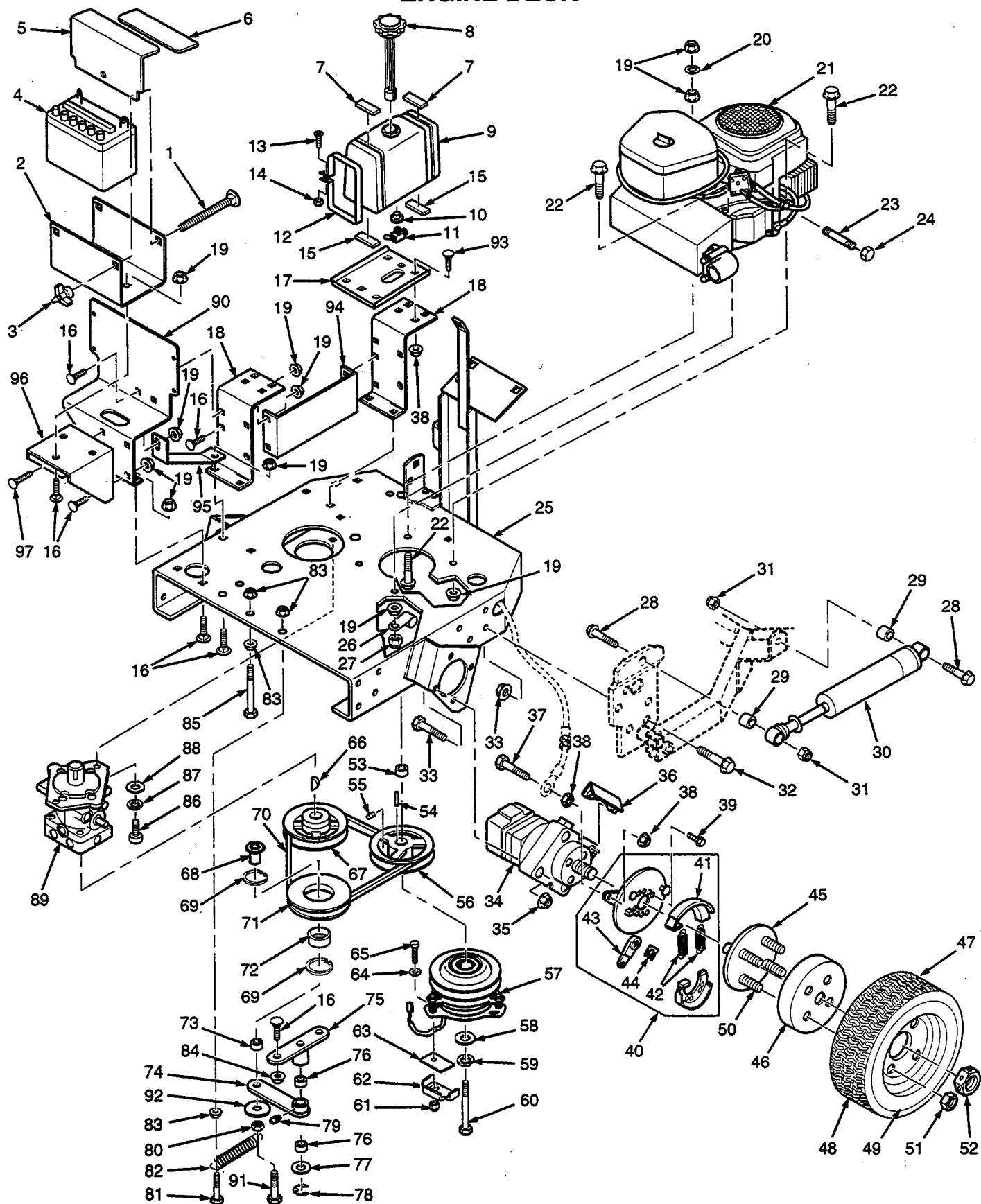

ENGINE DECK

Ref. No.	Part Number	Description	Ref. No.	Part Number	Description
1	*	Carriage Bolt, 1/4-20 x 6	47	48933	Rim and Tire Assembly (Includes items 48, 49)
2	42802	Battery Box	48	48933-02	Tire 20 x 10 x 10, 4 Ply
3	04029-01	Nut, Wing 1/4-20	49	48933-03	Rim Only
4	48015	Battery	50	04008-01	Bolt, Hub
5	42392	Battery Cover	51	*	Wheel Nut
6	48089	Insulation, Battery Cover	52	48813	Spring Locknut
7	48292	Pad, Fuel Tank Strap	53	43261	Spacer, Clutch
8	48658	Cap, Fuel Tank	54	04063-06	Key, 1/4 x 1/4 x 1-1/2
9	46174	Fuel Tank Assy. (Includes items 10 - 11)	55	*	Hex Socket Set Screw, 5/16-18 x 3/8
10	48309	Bushing, Fuel Tank Valve	56	48792	Pulley, Engine Pump
11	48308	Fuel Shut Off Valve	57	48786	Clutch, Electric
12	421239	Strap, Fuel Tank	58	04041-18	Flatwasher, 7/16
13	*	Phil RDHD Machine Screw 1/4-20 x 2	59	*	Lockwasher, 7/16
14	*	Hex Nut, 1/4-20	60	*	Bolt, Hex Head 7/16-20 x 3
15	48205	Pad, Fuel Tank Support	61	*	Hex Locknut, Elastic Stop 5/16-18
16	*	Carriage Bolt, 5/16-18 x 3/4	62	421564	Backing Plate, Clutch Stop
17	42377	Support, Fuel Tank	63	48814	Rubber Pad, Clutch Stop
18	421522	Bracket, Fuel Tank Support	64	*	Flatwasher, 5/16
19	04019-03	Serr. Fl. Hex Nut 5/16-18	65	*	Bolt, Hex Head 5/16-18 x 1-1/4
20	*	Lockwasher, 5/16 Int. Tooth	66	04063-12	Key, Woodruff 3/16 x 5/8
21	*	Engine, 20 HP Kohler CV	67	48581	Pulley, Pump Input
	*	Engine, 22 HP Kohler CV	68	43117	Sleeve, Idler
22	04017-20	Serr. Fl. Hex Head CPSCR, 5/16-18 x 1 3/4	69	*	Ring, Retaining
23	48402-02	Oil Drain Extension	70	48854	Belt, Pump Drive
24	48257	Cap, Plug	71	46370	Pulley, Idler - Traction Drive (Includes items 68, 69, 72)
25	45586	Engine Deck	72	48102	Bearing, Idler Pulley
26	48030-09	Wire Loom	73	43063	Spacer, Idler
27	*	Hex Locknut, Elastic Stop 5/16-18	74	46327	Pump Idler Arm (includes items 76, 79)
28	*	Bolt, Hex Head 1/2-13 x 2	75	45037	Idler Pivot Base
29	43041	Sleeve, Shock Absorber Mount	76	48100-05	Bushing, Bronze
30	48516	Shock Absorber	77	04041-08S	Flatwasher, 3/4
31	*	Hex Locknut, Elastic Stop 1/2-13	78	*	Ring, Retaining
32	04017-36	Serr. Fl. Hex Head CPSCR, 7/16-14 x 1	79	48114-04	Grease Fitting
33	04019-05	Serr. Fl. Hex Nut, 7/16-14	80	*	Hex Nut, Jam 3/8-16
34	48769	Motor - White (Includes item 52)	81	*	Bolt, Hex Head 3/8-16 x 3-1/4
35	04019-06	Serr. Fl. Hex Nut, 1/2-13	82	48929	Spring, Pump Drive Idler
36	421289	Anchor, Brake	83	04019-04	Serr. Fl. Hex Nut, 3/8-16
37	*	Bolt, Hex Head 1/4-20 x 1-1/4	84	04019-03	Serr. Fl. Hex Nut, 5/16-18
38	04019-01	Serr. Fl. Hex Nut, 1/4-20	85	*	Bolt, Hex Head 3/8-16 x 5
39	04017-16	Serr. Fl. Hex Head CPSCR, 5/16-18 x 3/4	86	04015-03	Socket Head CPSCR, 1/2-13 x 1-1/4
40	48461	Parking Brake Assembly	87	*	Lockwasher, 1/2
41	48461-02	Brake Pads- Pair	88	*	Flatwasher, 1/2
42	48461-03	Springs - Pair	89	48438	Pump, Sundstrand
43	48461-04	Actuating Arm	90	421520	Bracket, Oil Tank Support
44	48461-05	Clip	91	*	Bolt, Hex Head 3/8-16 x 1-3/4
45	46332	Hub Assembly (Includes item 50)	92	04041-10	Washer 2" OD, 3/8 ID, 16 Ga.
46	48589	Brake Drum	93	*	Carriage Bolt, 1/4-20 x 3/4

* Common hardware which should be purchased locally. All bolts grade 5 plated, all other fasteners zinc plate.

UPPER HYDRAULICS

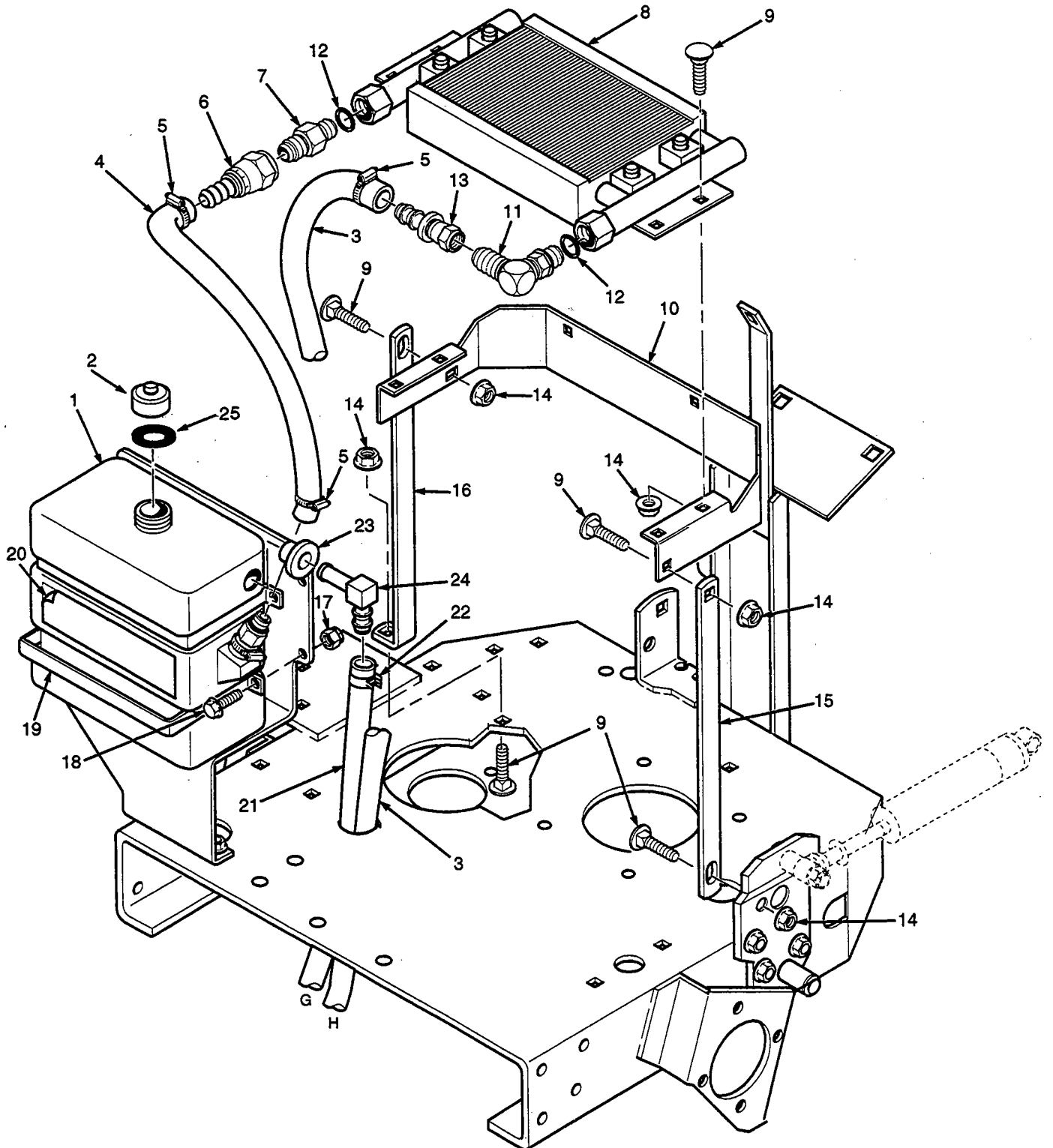

UPPER HYDRAULICS

Ref. No.	Part Number	Description
1	46621	Tank, Hydraulic w/ Decal
2	48894	Cap, Hydraulic Tank
3	48634	Hose, Pump to Oil Cooler
4	48942	Hose, Oil Cooler to Tank
5	48136-04	Clamp, Hose
6	48936-01	Coupling, Flare Swivel
7	48572-05	Tube, Union
8	48645	Oil Cooler Assembly
9	*	Carriage Bolt, 5/16-18x 3/4
10	421279	Bracket, Oil Cooler
11	48350-05	Elbow, 90 Degrees
12	48603-02	O-Ring
13	48353-04	Coupling Flare Swivel
14	04019-03	Serr. Fl. Hex Head Nut, 5/16-18
15	421280	Brace, L.H. Cooler Support
16	421281	Brace, R.H. Cooler Support
17	*	Elastic Stop Nut, 1/4-20
18	04017-05	Serr. Fl. Hex Head CPSCR, 1/4-20 x 3/4
19	421288	Strap, Oil Tank
20	48968	Decal, Scag
21	48482	Hose
22	48059-01	Clamp
23	48309	Bushing
24	48938	90 Degree Elbow
25	481090	Gasket, Rubber

* Common hardware which should be purchased locally. All bolts grade 5 plated, all other fasteners zinc plate.

LOWER HYDRAULICS

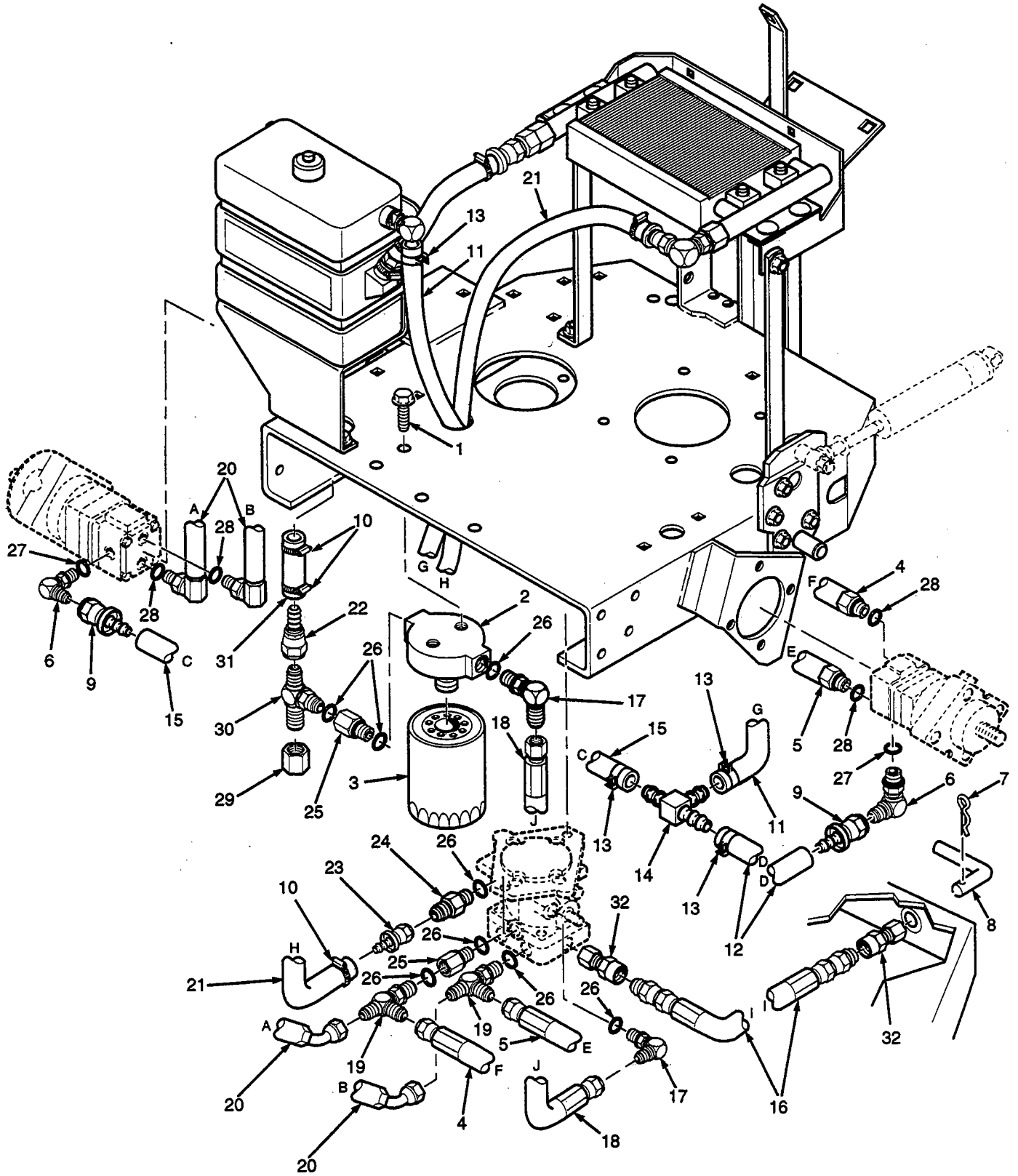

LOWER HYDRAULICS

Ref. No.	Part Number	Description
1	04017-04	Serr. Fl. Hex Head CPSCR, 1/4-20 x1/2
2	48462-02	Filter Head
3	48758	Filter, Spin-On Lube
4	48991	Hose Assembly
5	48688	Hose Assembly
6	48350-03	Elbow, 90 Degrees
7	04062-01	Hairpin Cotter
8	44088	Lever, Dump Valve
9	48353-02	Connector, Flare Swivel with Hose Barb
10	48136-04	Hose Clamp
11	48482-12	Hose, 1/4 Pushlock
12	48482-05	Hose, 1/4 Pushlock
13	48059-01	Hose Clamp
14	48935-01	Tee Union, Pushlock Hose
15	48482-05	Hose, 1/4 Pushlock
16	48853	Hose, Dump Valve
17	48350-05	Elbow
18	48856	Inlet Hose, 3/4" ID
19	48937-01	Tee, 1/2" Run
20	48905	Motor Hose
21	48634	Hose, Pump To Oil Cooler
22	48936-01	Coupling, Flare Swivel
23	48353-02	Coupling, Flare Swivel With Barb
24	48572-04	Tube Union
25	48938-01	O-Ring Bushing
26	48603-02	O-Ring
27	48603-03	O-Ring
28	48603-04	O-Ring
29	48571-03	Cap
30	48810-02	Tee, Jic to O-Ring
31	48602-04	Hose
32	48911001	Compression Fitting

* Common hardware which should be purchased locally. All bolts grade 5 plated, all other fasteners zinc plate.

CONTROL LINKAGE

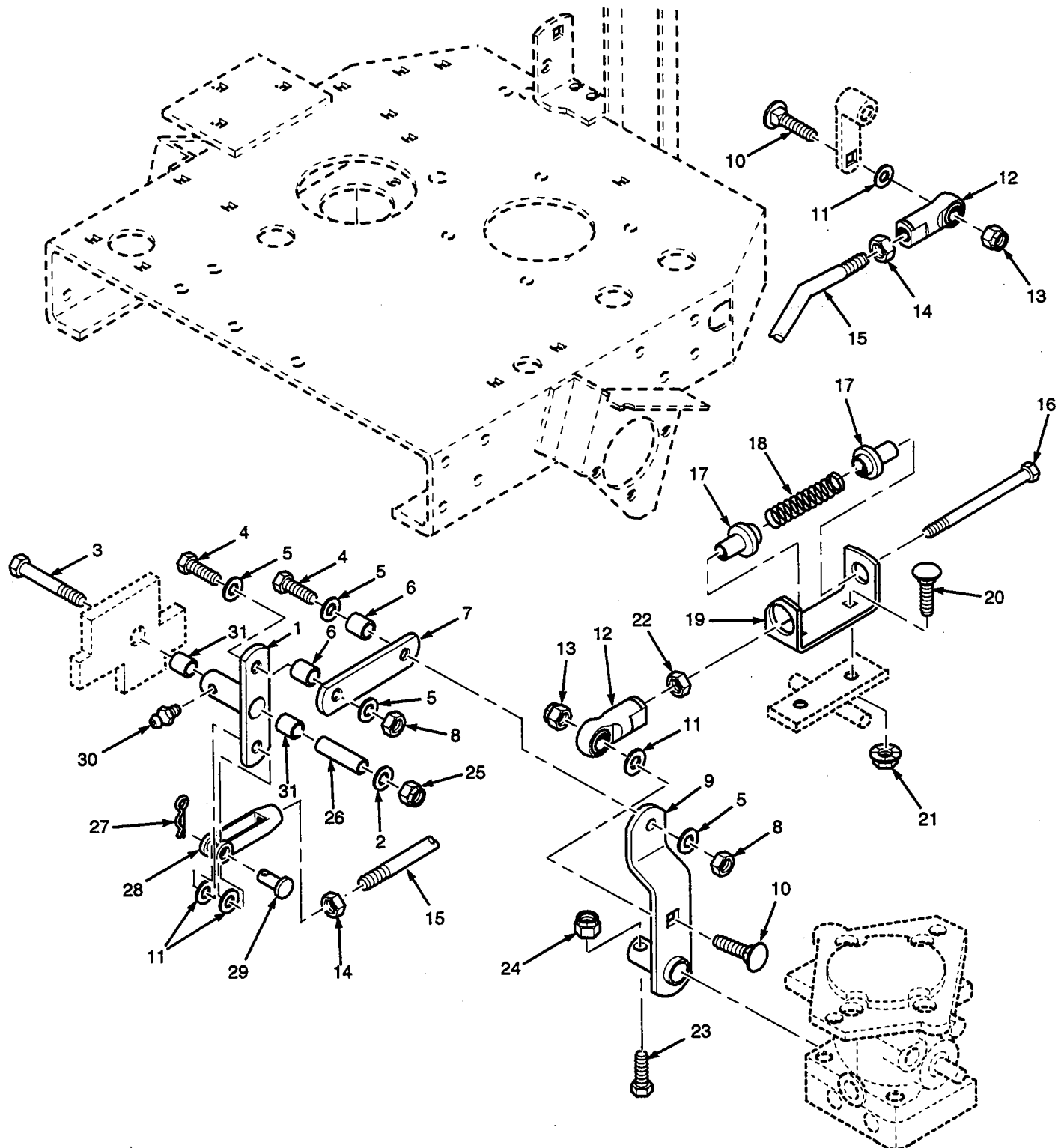

CONTROL LINKAGE

Ref. No.	Part Number	Description
1	45261	Control Linkage, Bellcrank
2	*	Flatwasher, 5/16
3	*	Bolt, Hex Head 5/16-18 x 2-3/4
4	*	Bolt, Hex Head 3/8-16 x 1
5	*	Flatwasher, 3/8
6	43212	Sleeve, Pump Control Link
7	42658	Link, Speed Control
8	*	Hex Locknut, 3/8-16
9	45485	Control Arm, Pump
10	*	Carrage Bolt, RH SH SQNK 3/8-16 x 1-1/2
11	*	Flatwasher, 3/8 x 15/16 x 12 ga.
12	48464	Rod End, RH Female THD 3/8-24
13	*	Hex Locknut, Elastic Stop 3/8-16
14	*	Hex Nut, 3/8-24
15	44044	Control Rod
16	48512	Bolt Hex Head, 3/8-24 x 6-3/4
17	43257	Bushing, Spring Keeper
18	48463	Spring, Neutral Return
19	421148	Retainer, Neutral Spring
20	*	Carrage Bolt, 5/16-18 x 1
21	04019-03	Serr. Fl. Hex Nut 5/16-18
22	*	Hex Nut, 3/8-24
23	*	Bolt, Hex Head 1/4-20 x 1-1/4
24	*	Hex Locknut, Elastic Stop 1/4-20
25	*	Hex Locknut, Elastic Stop 5/16-18
26	43110	Sleeve, Control Arm
27	04061-02	Cotter Pin, 3/32 x .75
28	48343-02	Clevis, Pump Control
29	44024	Pin, Clevis
30	48114-04	Greese Fitting, 1/4-28 Self Tap
31	48100-04	Bushing, Bronze

INSTRUMENT PANEL AND ELECTRICAL COMPONENTS

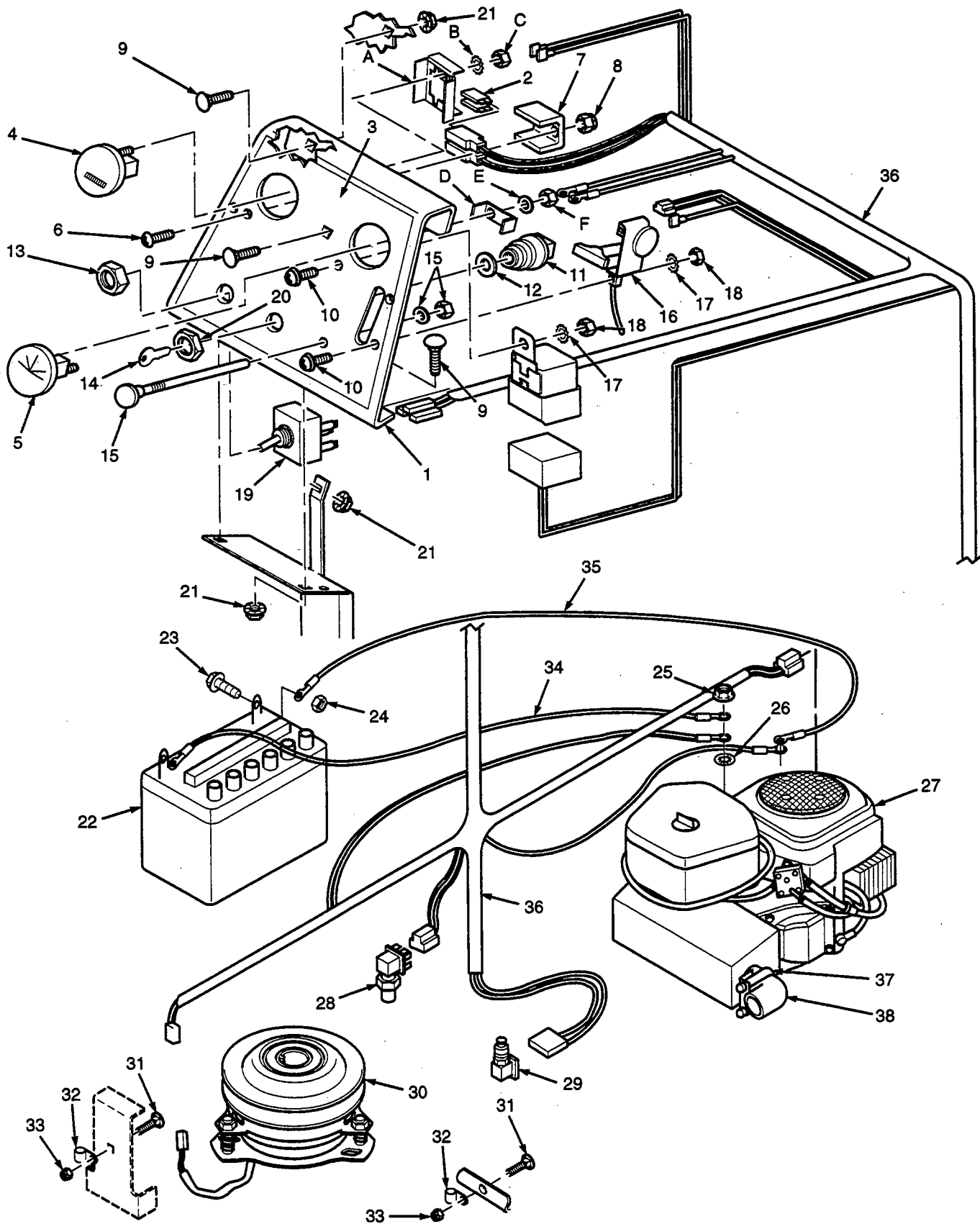

INSTRUMENT PANEL AND ELECTRICAL COMPONENTS

Ref. Part No.	Part Number	Description
1	46622	Instrument Panel (includes Decal)
2	*	Blade Fuse, 20 amp.
3	48460	Decal, Instrument Panel
4	48023	Hour Meter (includes Bracket and Hardware A, B, C)
A	*	Hour Meter Bracket
B	*	Lockwasher, #10 Ext. Tooth
C	*	Hex Nut, 10-24
5	48022	Ammeter (Includes Bracket and Hardware D, E, F)
D	*	Ammeter Bracket
E	*	Lockwasher, #10 Int. Tooth
F	*	Hex Nut, #10-32
6	*	Phillips Rd. Head Screw, #10-32 x 1-1/2
7	42413	Bracket, Fuse Holder
8	*	Elastic Stop Nut, #10-32
9	*	Carriage Bolt, 5/16-18 x 3/4
10	*	Phillips Washer Head Screw,
11	48798	Keyswitch
12	*	Lockwasher, 5/8 Int. Tooth
13	*	Nut, Special 1/2-27
14	48017-02	Ignition Key and Ring Assy.
15	48091	Choke Control (includes hardware)
16	48879	Throttle Control
17	*	Lockwasher, #10 Ext. Tooth
18	*	Hex Nut, #10-32
19	48787	Switch, PTO
20	*	Nut, Special 5/8-32
21	04019-03	Serr. Fl. HH Nut, 5/16-18
22	48015	Battery
23	*	Bolt, Hex head 1/4-20 x 1/2
24	*	Hex Nut 1/4-20
25	04019-03	Serr Fl. Hex Head Nut 5/16-18
26	*	Lockwasher 5/16 Int. Tooth
27	*	Engine, 20 HP Kohler CV
	*	Engine, 22 HP Kohler CV
28	48522	Switch, Parking Brake
29	48026	Switch, Foot Safety
30	48786	Clutch, Electric
31	*	Carriage Bolt, 5/16-18 x 3/4
32	48030-09	Wireloom
33	*	Locknut, Elastic Stop 5/16-18
34	48029-15	Battery Cable, 36" Black
35	48029-13	Battery Cable, 25" Red
36	481059	Wire Harness, STHM
37	48633	Clamp
38	48932	Elbow

* Common hardware which should be purchased locally. All bolts grade 5 plated, all other fasteners zinc plate.

RIDER FRAME ASSEMBLY

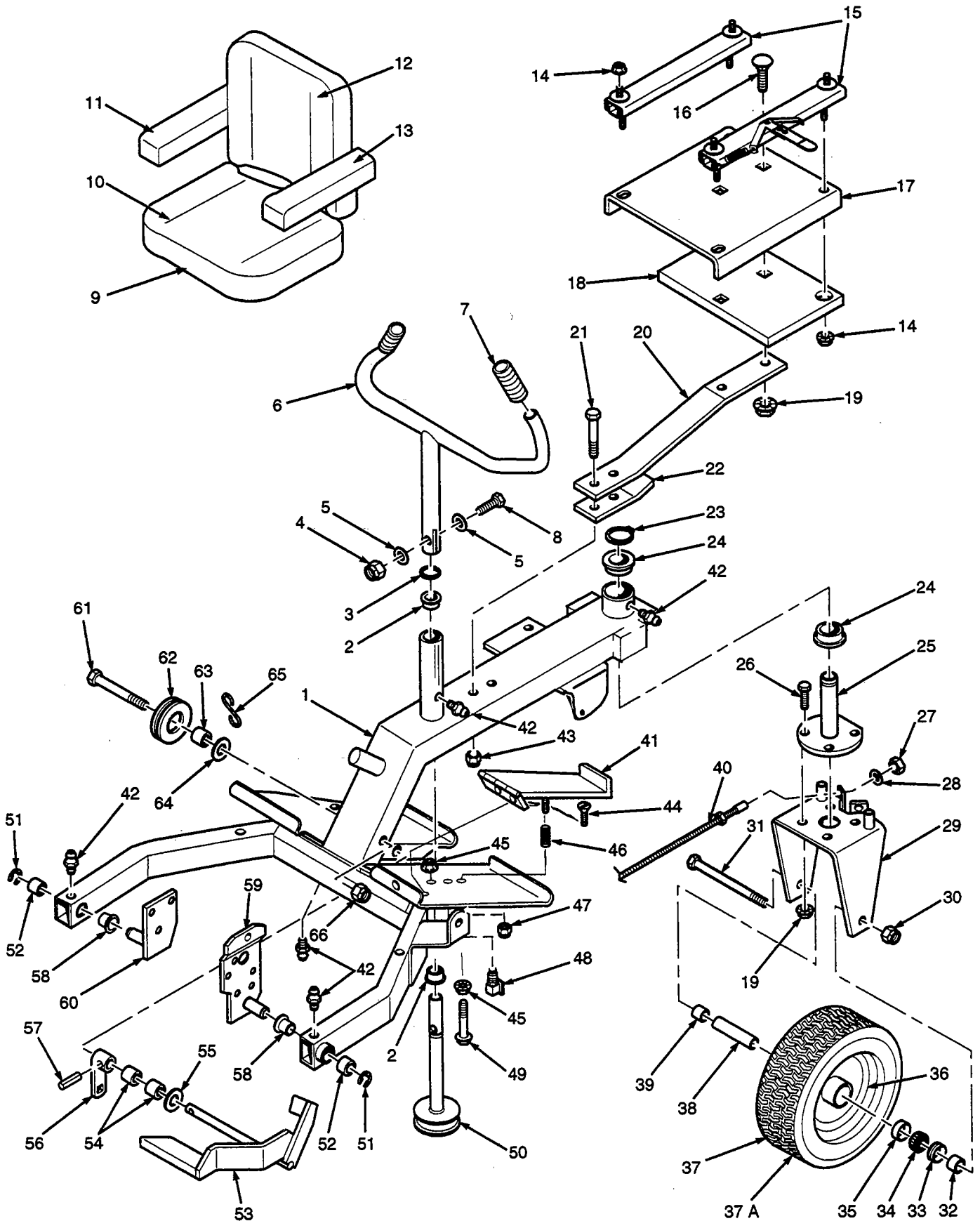

RIDER FRAME ASSEMBLY

Ref. No.	Part Number	Description	Ref. No.	Part Number	Description
1	46715	Steering Frame (Includes Bshgs and Fittings)	57	04065-01	Pin, Drive Lock 3/16 x 1-1/4"
2	48100-07	Bronze Bushing	58	48100-03	Bronze Bushing
3	04050-03	Retaining Ring, 7/8 external	59	45488	Sulky Mtg. Brkt. L.H.
4	*	Hex Nut, Elastic Stop 5/16-18	60	45256	Sulky Mtg. Brkt. R.H.
5	*	Flat Washer, 3/8 x 7/8 x 13 ga.	61	*	Bolt, Hex Hd., 1/2-13 x 5-1/2"
6	46029	Steering Handle (includes item 7)	62	48208	Pulley, Winch Cable
7	48159	Grip	63	48100-04	Bronze Bushing
8	*	Bolt, Hex Hd., 5/16-18 x 1-3/4"	64	*	Flat Washer, 1/2 (.562 x 1.375 x .189)
9	48930	Seat Assy. (includes items 10 thru 15)	65	44028	Retainer, Winch Cable
10	48704-03	Cushion Assembly	66	04021-07	Hex Elastic Stop Nut, 1/2-13
11	48704-04	Arm Pad - R.H.			
12	48704-02	Seat Back Cushion			
13	48704-05	Arm Pad L.H.			
14	04019-03	Serr. Fl. HH. Nut, 5/16-18			
15	48931	Seat Adjuster Track			
16	*	Bolt, RDHD Carr. 3/8-16 x 1-1/2			
17	421342	Seat Plate			
18	42482	Ballast, Seat Mount (72" cutter deck only)			
19	04019-04	Serr Fl. Hex Nut, 3/8-16			
20	42026	Seat Spring			
21	*	Bolt, Hex Hd., 7-16-14 x 3-1/2			
22	42366	Reinforcement, Seat Spring			
23	04050-05	Retaining Ring, 1-1/8" external			
24	48100-02	Bronze Bushing			
25	45008	Rear Wheel Pivot			
26	*	Bolt, Hex Hd., 3/8-16 x 1-1/4			
27	*	Hex Nut, 3/8-24			
28	*	Lock Washer, 3/8 Internal Tooth			
29	45035	Rear Wheel Yoke			
30	04021-13	Hex Elastic Stop Nut, 5/8-11			
31	04001-40	Bolt, Hex Hd. 5/8-11 x 9"			
32	43020-01	Spacer, Rear Wheel, short			
33	48005-06	Seal, Grease			
34	48005-05	Bearing Cone			
35	48005-04	Bearing Cup			
36	48005-03	Rim Only			
37	48005	Rear Wheel Assy. (Includes items 33-36, 37A)			
37A	48005-02	Tire Only			
38	43021	Sleeve, Rear Wheel			
39	43020-02	Spacer, Rear Wheel			
40	48828	Cable, Steering (Includes Hardware)			
41	45606	Pedal, Foot Safety Switch			
42	48114-04	Grease Fitting			
43	*	Hex Elastic Stop Nut, 7/16-14			
44	*	Screw, slotted flat hd #10-32 x 3/4"			
45	04019-02	Serr. Fl. Hex Nut, 1/4-20			
46	481056	Spring, Foot Safety Switch			
47	04021-08	Hex Nut, Elastic Stop Lock, 1/4-20			
48	48026	Switch, Foot Safety			
49	*	Bolt, Hex Hd., 1/4-20 x 1-3/4			
50	45009	Steering Shaft			
51	04050-02	Retaining Ring 3/4 Ext. "E"			
52	48100-06	Bronze Bushing			
53	45502	Foot Pedal			
54	48100-06	Bronze Bushing			
55	*	Flat Washer, 3/4 x 1-1/4 x 16 Ga.			
56	45506	Foot Pedal Arm			

BRAKE LINKAGE

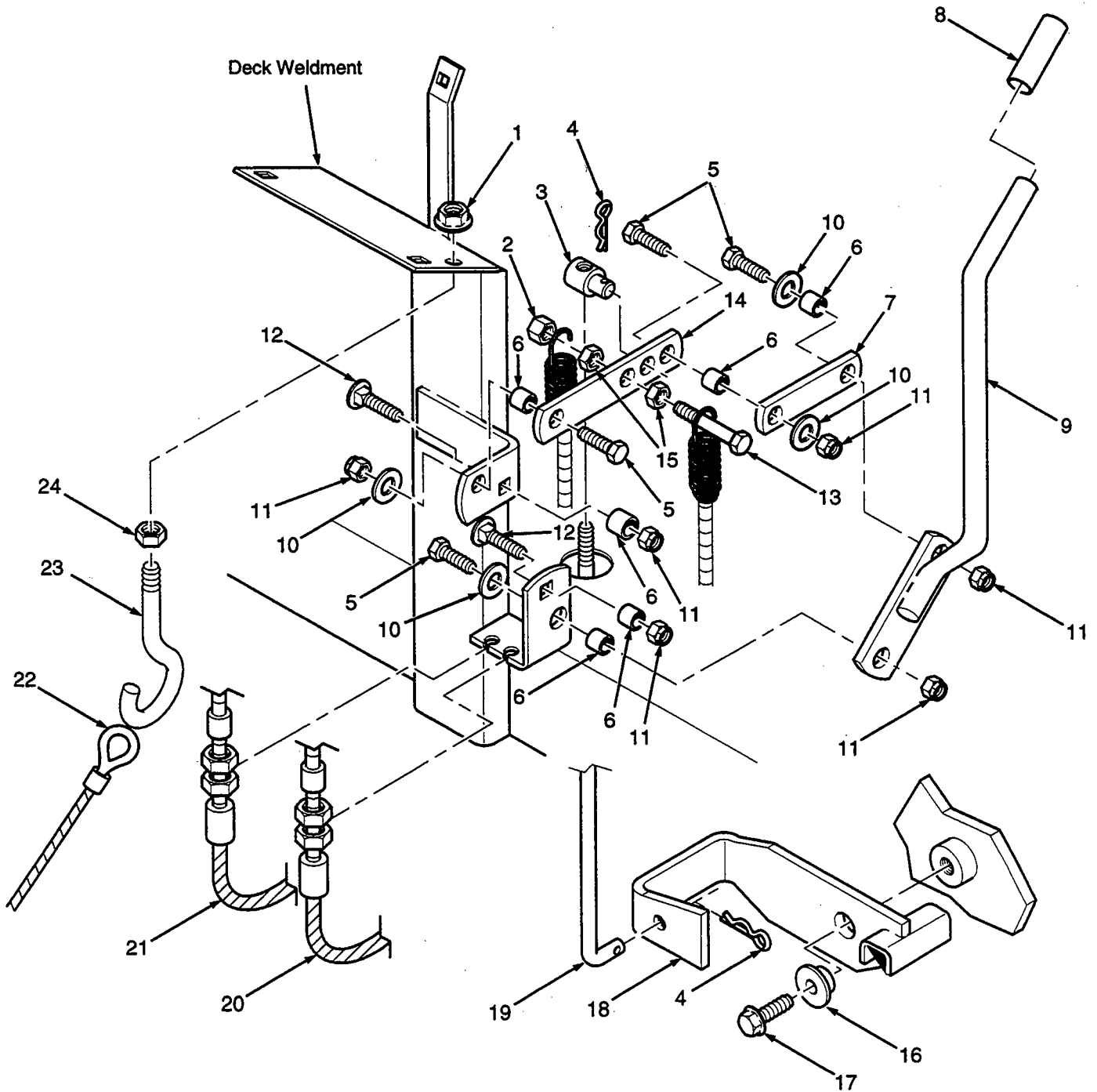

BRAKE LINKAGE

Ref. No	Part Number	Description
1	04019-04	Serr. Fl. HH Nut, 3/8-16
2	*	Hex Locknut, 3/8-16
3	43032	Swivel
4	04062-01	Cotter Pin
5	*	Hex Head Bolt, 3/8-16 x 1-1/4
6	43212	Sleeve, Hydro Linkage
7	421338	Link, Cam
8	48342	Grip, Parking Brake
9	45504	Handle, Parking Brake
10	*	Flat Washer, 3/8 x 15/16 x 12 Ga.
11	*	Hex Nut, Elastic Stop 3/8-16
12	*	Carriage Bolt, 3/8-16 x 1-1/4
13	*	Hex Head Bolt, 3/8-16 x 1-3/4
14	421339	Lever, Brake
15	*	Hex Jam Nut, 3/8-16
16	43260	Washer, Neutral Lock
17	04017-27	Serr. Fl. HH CPSCR, 3/8-16 x 1
18	45647	Bracket, Neutral Lock
19	44085	Rod, Neutral Lock
20	48881	Cable Assembly, Parking Brake R.H.
21	48880	Cable Assembly, Parking Brake L.H.
22	48045	Cable Winch
23	04070-03	Eye Bolt, 3/8-16 R.H.
24	*	Hex Nut, 3/8-16

* Common hardware which should be purchased locally. All bolts grade 5 plated, all other fasteners zinc plate.

ELECTRICAL SYSTEM

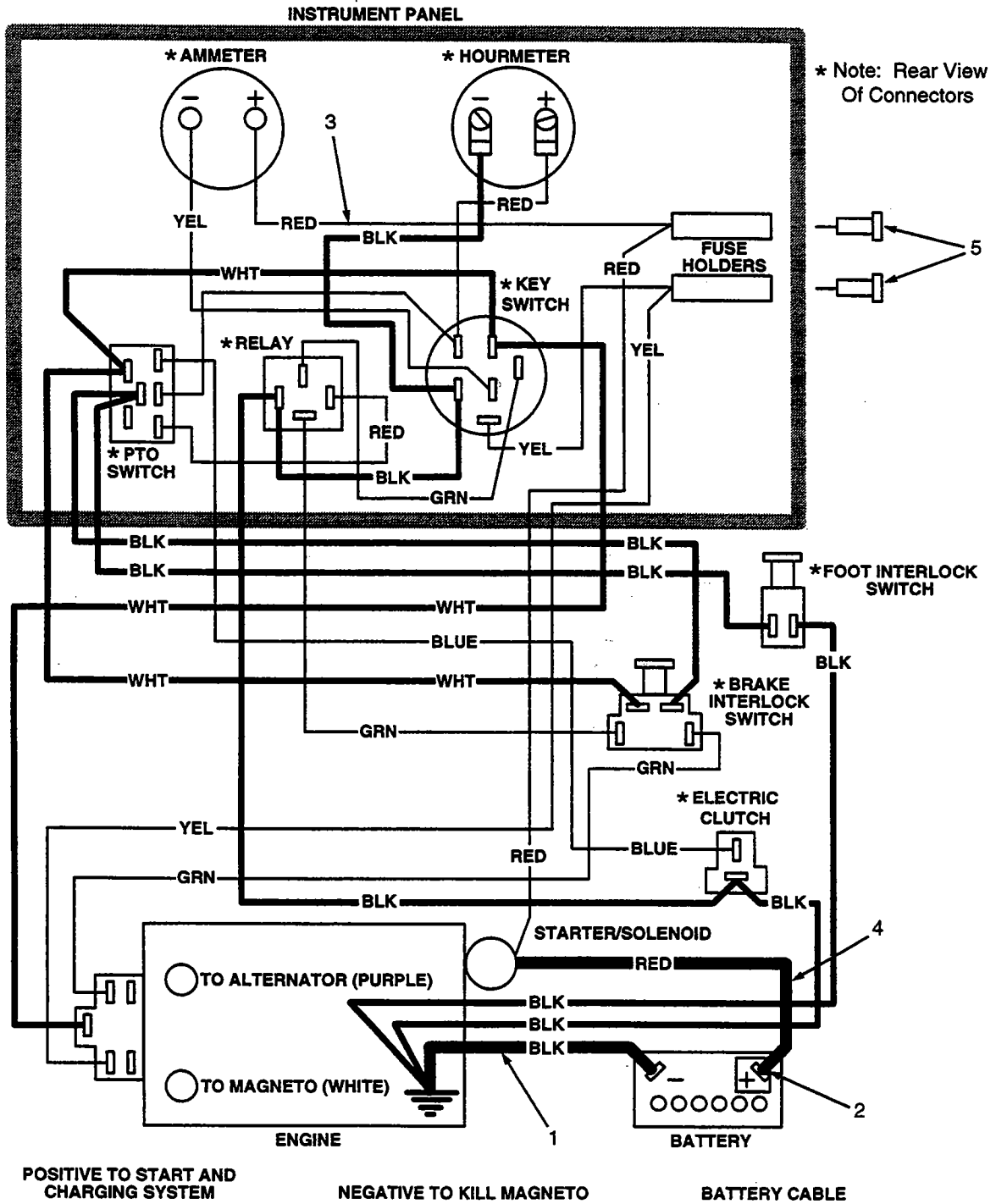

Ref. No.	Part Number	Description	Ref. No.	Part Number	Description
1	48029-15	Battery Cable, 36" Black	5	48298	Fuse, 20 AMP Bldee Automotive
	48129	Rubber Boot	NS	48028-05	Cable Tie
3	481059	Wire Harness, STHM			
4	48029-13	Battery Cable, 25" Red			

* Common hardware which should be purchased locally. All bolts grade 5 plated, all other fasteners zinc plate.

WINCH LIFT SYSTEM

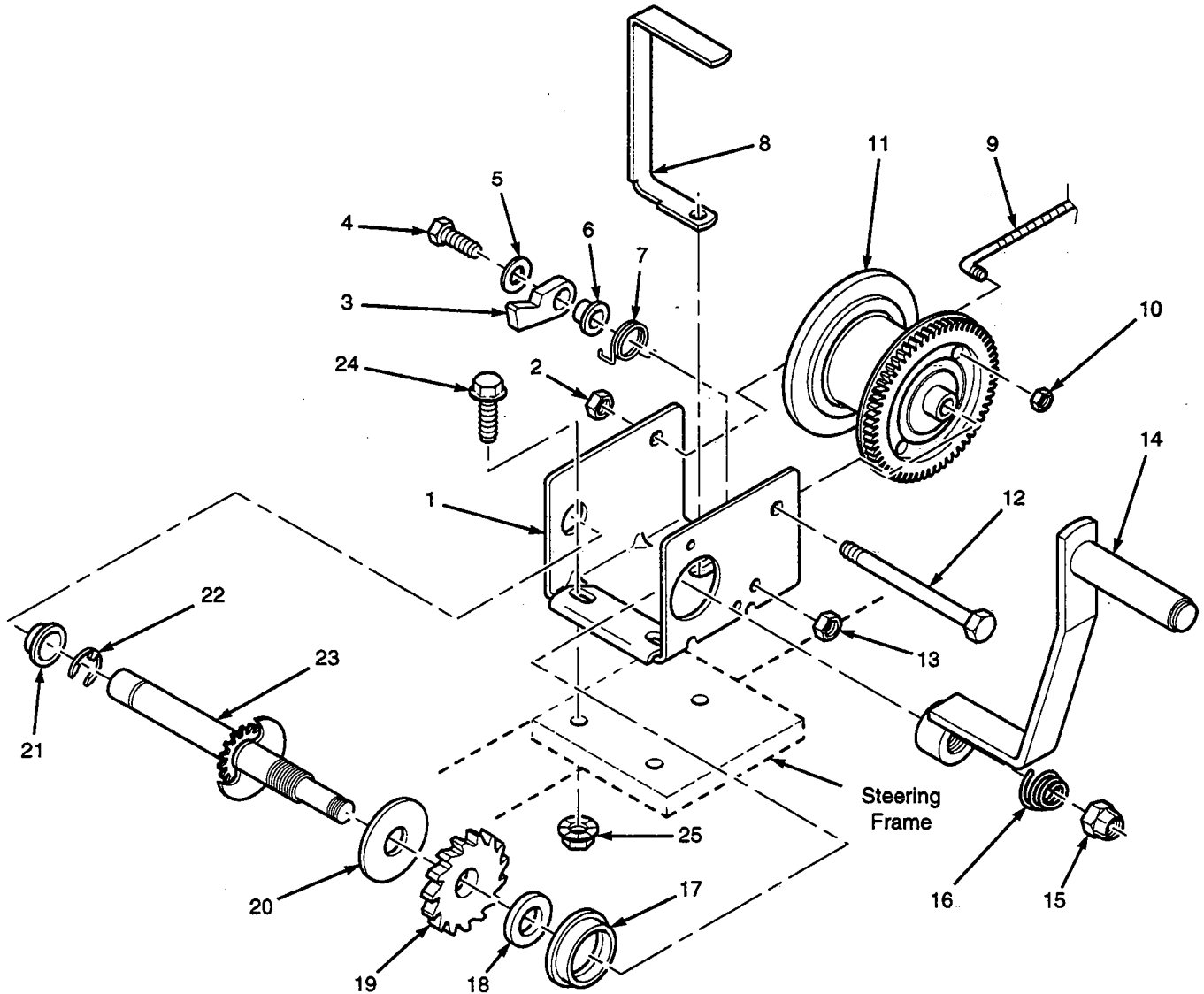

Ref. Part No.	Part Number	Description	Ref. Part No.	Part Number	Description
1	48043	Winch Assembly (incl. 1-7, 11-23)	14	48044	Winch Handle
2	205155	Locknut, 7/16-14	15	205015	Handle Nut
3	404409	Ratchet Pawl	16	204364	Handle Spring
4	205167	Ratchet Bolt	17	204359	Shaft Bushing
5	205024	Flatwasher	18	404163	Pressure Washer
6	404166	Ratchet Spacer	19	404164	Ratchet Wheel
7	204363	Ratchet Spring	20	204362	Pressure Plate
8	42127	Cable Guide	21	204009	Shaft Bushing
9	48045	Winch Cable Assembly	22	205116	E-Ring
10	04021-03	Hex Locknut, 1/4-28	23	304228	Drive Shaft
11	304227	Winch Reel	24	*	Serr. FLG HH CPSCR, 3/8-16 x 1
12	205008	Reel Shaft	25	*	Serr. FLG HH Nut, 3/8-16
13	205011	Hex Locknut, 3/8-16			

* Common hardware which should be purchased locally. All bolts grade 5 plated, all other fasteners zinc plate.

REPLACEMENT DECALS & INFORMATION



1



2, 2a, 2b



3

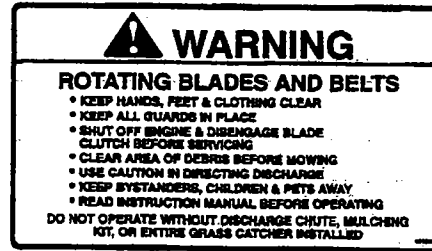

4

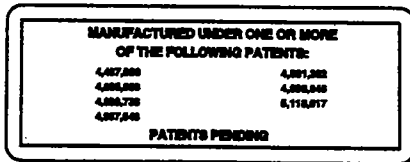

5



6



7

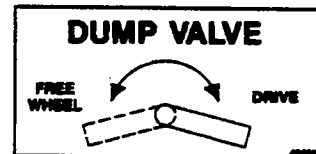

8



9



10, 11, 12

Ref. No.	Part Number	Description	Ref. No.	Part Number	Description
1	48072	Decal, Heavy Duty Commercial	6	48895	Decal, Instrument Panel
2	48314	Decal, Scag Logo (Cutter Deck)	7	481039	Decal, Warning-Belt Cover
2a	48968	Decal, Scag Logo (Battery Box Front)	8	48993	Decal, Dump Valve
2b	48825	Decal, Scag Logo Seatback	9	48404	Decal, Metalcraft-Made In USA
3	48071	Decal, Danger-Spinning Blades	10	48319	Decal, 52
4	481040	Decal, Warning-Rotating Blades	11	48320	Decal, 61
5	48656	Decal, Patent	12	48327	Decal, 72

PLEASE BE CAREFUL !

- * Keep all shields in place, especially the grass discharge chute.
- * Before performing any maintenance or service, stop the machine and remove the spark plug wire.
- * If a mechanism becomes clogged, stop the engine before cleaning.
- * Keep hands, feet and clothing away from power-driven parts.
- * Do not operate the mower without a seat.
- * Keep others off the tractor (only one person at a time).

REMEMBER - YOUR MOWER IS ONLY AS SAFE AS THE OPERATOR!

**FAILURE TO FOLLOW SAFE OPERATING PRACTICES
MAY RESULT IN SERIOUS INJURY.**

This manual covers the operating instructions
and illustrated parts list for:

**All STHM model machines
with a serial number of 50001-59999**

The serial number is the last 5 digits listed on the
serial number tag mounted to the engine deck

© 1994
SCAG POWER EQUIPMENT
DIVISION OF METALCRAFT OF MAYVILLE

PART NO. 03007
PRINTED 8/94
PRINTED IN USA

Free Manuals Download Website

<http://myh66.com>

<http://usermanuals.us>

<http://www.somanuals.com>

<http://www.4manuals.cc>

<http://www.manual-lib.com>

<http://www.404manual.com>

<http://www.luxmanual.com>

<http://aubethermostatmanual.com>

Golf course search by state

<http://golfingnear.com>

Email search by domain

<http://emailbydomain.com>

Auto manuals search

<http://auto.somanuals.com>

TV manuals search

<http://tv.somanuals.com>