

# SCAG<sup>®</sup>

## POWER EQUIPMENT

### MODEL STT

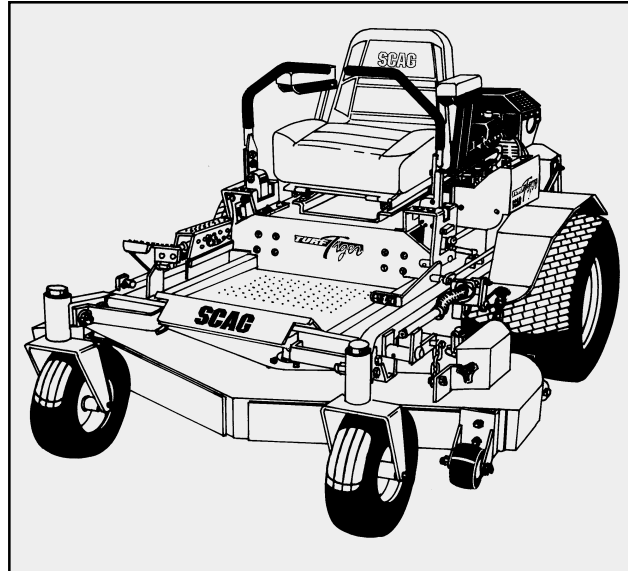

THIS MANUAL CONTAINS THE OPERATING INSTRUCTIONS AND SAFETY INFORMATION FOR YOUR SCAG MOWER. READING THIS MANUAL CAN PROVIDE YOU WITH ASSISTANCE IN MAINTENANCE AND ADJUSTMENT PROCEDURES TO KEEP YOUR MOWER PERFORMING TO MAXIMUM EFFICIENCY. THE SPECIFIC MODELS THAT THIS BOOK COVERS ARE CONTAINED ON THE INSIDE COVER. BEFORE OPERATING YOUR MACHINE, PLEASE READ ALL THE INFORMATION ENCLOSED.

OPERATOR'S MANUAL

PART NUMBER 03059



# WARNING:

## **FAILURE TO FOLLOW SAFE OPERATING PRACTICES MAY RESULT IN SERIOUS INJURY.**

- \* Keep all shields in place, especially the grass discharge chute.
- \* Before performing any maintenance or service, stop the machine and remove the spark plug wire and ignition key.
- \* If a mechanism becomes clogged, stop the engine before cleaning.
- \* Keep hands, feet and clothing away from power-driven parts.
- \* Read this manual completely as well as other manuals that came with your mower.
- \* Keep others off the tractor (only one person at a time)

## **REMEMBER - YOUR MOWER IS ONLY AS SAFE AS THE OPERATOR!**

**Hazard control and accident prevention are dependent upon the awareness, concern, prudence, and proper training of the personnel involved in the operation, transport, maintenance, and storage of the equipment.**

This manual covers the operating instructions  
and illustrated parts list for:

**STT52-22CH with a serial number of 4260001- 4269999**  
**STT52B-22CH with a serial number of 4280001- 4289999**  
**STT61-22CH with a serial number of 4270001- 4279999**  
**STT61B-22CH with a serial number of 4290001- 4299999**  
**STT52-25CH with a serial number of 4300001- 4309999**  
**STT61-25CH with a serial number of 4310001- 4319999**  
**STT52B-25CH with a serial number of 4320001- 4329999**  
**STT61B-25CH with a serial number of 4330001- 4339999**  
**STT52-22KA with a serial number of 4340001- 4349999**  
**STT61-22KA with a serial number of 4350001- 4359999**  
**STT52B-22KA with a serial number of 4360001- 4369999**  
**STT61B-22KA with a serial number of 4370001- 4379999**

Always use the entire serial number listed on the serial number tag when referring to this product.

## GENERAL INFORMATION

### 1.1 INTRODUCTION

Your mower was built to the highest standards in the industry. However, the prolonged life and maximum efficiency of your mower depends on you following the operating, maintenance and adjustment instructions in this manual.

If additional information or service is needed, contact your Scag Power Equipment Dealer.

We encourage you to contact your dealer for repairs. All Scag dealers are informed of the latest methods to service this equipment and provide prompt and efficient service in the field or at their service shop. They carry a full line of Scag service parts.

#### USE OF OTHER THAN ORIGINAL SCAG REPLACEMENT PARTS WILL VOID THE WARRANTY.

When ordering parts, always give the model and serial number of your tractor. The serial number plate is located where shown in Figures 1-1.

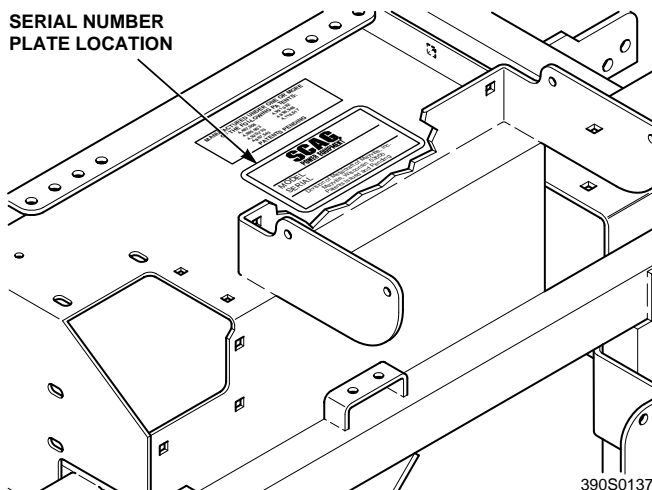

Figure 1-1 Tractor Serial Number Plate Location

For pictorial clarity, some illustrations and figures in this manual may show shields, guards or plates open or removed. Under no circumstances should your mower be operated without these devices in place.

**All information is based upon product information available at the time of approval for printing. Scag Power Equipment reserves the right to make changes at any time without notice and without incurring any obligation.**

### 1.2 DIRECTION REFERENCE

The “Right” and “Left”, “Front” and “Rear” of the machine are referenced from the operator’s right and left when seated in the normal operating position and facing the forward travel direction.

### 1.3 SERVICING THE ENGINE AND DRIVE TRAIN COMPONENTS

The detail servicing and repair of the engine, hydraulic pumps and gearboxes are not covered in this manual; only routine maintenance and general service instructions are provided. For service of these components during the limited warranty period, it is important to contact your Scag dealer or find a local authorized servicing agent of the component manufacturer. Any unauthorized work done on these components during the warranty period may void your warranty.

### SAFETY INFORMATION

#### 2.1 INTRODUCTION

Your mower is only as safe as the operator. Carelessness or operator error may result in serious bodily injury or death. Hazard control and accident prevention are dependent upon the awareness, concern, prudence, and proper training of the personnel involved in the operation, transport, maintenance and storage of the equipment. Make sure every operator is properly trained and thoroughly familiar with all of the controls before operating the mower.

#### READ THIS OPERATOR'S MANUAL BEFORE ATTEMPTING TO START YOUR MOWER.

A replacement manual is available from your authorized Scag Service Dealer or by contacting Scag Power Equipment, Service Department at P.O. Box 152, Mayville, WI 53050. Please indicate the complete model and serial number of your Scag product when requesting replacement manuals.

#### 2.2 SIGNAL WORDS



This symbol means "**Attention! Become Alert! Your Safety is Involved!**" The symbol is used with the following signal words to attract your attention to safety messages found on the decals on the machine and throughout this manual. The message that follows the symbol contains important information about safety. To avoid injury and possible death, carefully read the message! Be sure to fully understand the causes of possible injury or death.

#### Signal Word:

It is a distinctive word found on the safety decals on the machine and throughout this manual that alerts the viewer to the existence and relative degree of the hazard.

#### **DANGER:**

The signal word "DANGER" denotes that an extremely hazardous situation exists on or near the machine that could result in high probability of death or irreparable injury if proper precautions are not taken.

#### **WARNING:**

The signal word "WARNING" denotes that a hazard exists on or near the machine that can result in injury or death if proper precautions are not taken.

#### **CAUTION:**

The signal word "CAUTION" is a reminder of safety practices on or near the machine that could result in personal injury if proper precautions are not taken.

Your safety and the safety of others depends significantly upon your knowledge and understanding of all correct operating practices and procedures of this machine.

#### 2.3 BEFORE OPERATION CONSIDERATIONS

1. **NEVER** allow children to operate this riding mower. Do not allow adults to operate this machine without proper instructions.
2. **DO NOT** mow when children and/or others are present.
3. Clear the area to be mowed of objects that could be picked up and thrown by the cutter blades.
4. **DO NOT** carry passengers.

## Section 2

### 2.3 BEFORE OPERATION CONSIDERATIONS (CONT'D)

5. **DO NOT** wear loose fitting clothing that could get tangled in moving parts. Do not operate the machine wearing shorts; always wear adequate protective clothing including long pants. Wearing safety glasses, safety shoes and a helmet is advisable and is required by some local ordinances and insurance regulations.
6. Operator hearing protection is recommended, particularly for continuous operation of the mower. Wear suitable hearing protection. Prolonged exposure to loud noise can cause hearing impairment or loss.
7. Keep the machine and attachments in good operating condition. Keep all shields and safety devices in place. If a shield, safety device or decal is defective or damaged, repair or replace it before operating the machine.



#### **WARNING:**

**This machine is equipped with an interlock system intended to protect the operator and others from injury. This is accomplished by preventing the engine from starting unless the deck drive is disengaged, the parking brake is on, the steering control levers are in the neutral position and the operator is in the seat. The system shuts off the engine if the operator leaves the seat with the deck drive engaged and/or the steering control levers are not in the neutral position and the parking brake is not engaged. Never operate equipment with the interlock system disconnected or malfunctioning.**

8. Be sure the interlock switches are functioning correctly.
9. Fuel is flammable; handle it with care. Fill the fuel tank outdoors. Never fill it indoors. Use a funnel or spout to prevent spillage. Clean up any spillage before starting the engine.

10. **DO NOT** add fuel to a running or hot engine. Allow the engine to cool for several minutes before adding fuel.
11. Keep flammable objects (cigarettes, matches, etc.), open flames and sparks away from the fuel tank and fuel container.
12. Equipment must comply with the latest requirements per SAE J137 and/or ANSI/ASAE S279 when driven on public roads.

#### **-NOTE-**

*If the mower is driven on public roads, it must comply with state and local ordinances as well as SAE J137 and/or ANSI / ASAE S279 requirements. Contact your local authorities for regulations and equipment requirements.*

13. **DO NOT** operate without the side discharge chute installed and in the down position.
14. Check the blade mounting bolts at frequent intervals for proper tightness.
15. Make sure all hydraulic fluid connections are tight and all hydraulic hoses and lines are in good condition before starting the machine.

### 2.4 OPERATION CONSIDERATIONS

1. Know the function of all controls and how to stop quickly.
2. Reduce speed and exercise extreme caution on slopes and in sharp turns to prevent tipping or loss of control. Be especially cautious when changing directions on slopes.



#### **WARNING:**

**DO NOT operate on steep slopes. To check a slope, attempt to back up it (with the cutter deck down). If the machine can back up the slope without the wheels slipping, reduce speed and use extreme caution. ALWAYS FOLLOW OSHA APPROVED OPERATION.**

### 2.4 OPERATION CONSIDERATIONS (CONT'D)

3. To prevent tipping or loss of control, do not start or stop suddenly, avoid unnecessary turns and travel at reduced speed.
4. When using any attachment, never direct the discharge of material toward bystanders or allow anyone near the machine while in operation.
5. Before attempting to start the engine, with the operator in the seat, disengage power to the cutter deck, place the steering control levers in the neutral position and engage the parking brake.
6. If the mower discharge ever plugs, shut off the engine, remove the ignition key, and wait for all movement to stop before removing the obstruction. Do not use your hand to dislodge the clogged discharge chute. Use a stick or other device to remove clogged material.
7. Be alert for holes, rocks, roots and other hidden hazards in the terrain. Keep away from any dropoff. Beware of overhead obstructions (low limbs, etc.), underground obstacles (sprinklers, pipes, tree roots, etc.). Cautiously enter a new area. Be alert for hidden hazards.
8. Disengage power to cutter deck before backing up. Do not mow in reverse unless absolutely necessary and then only after observation of the entire area behind the mower.
9. **DO NOT** turn sharply. Use care when backing up.
10. Disengage power to cutter deck before crossing roads, walks or gravel drives.
11. Mow only in daylight or good artificial light.
12. Take all possible precautions when leaving the machine unattended, such as disengaging the mower, lowering the attachments, setting the parking brake, stopping the engine, and removing the key.
13. Disengage power to the attachments when transporting or when not in use.
14. The machine and attachments should be stopped and inspected for damage after striking a foreign object, and damage should be repaired before restarting and operating the machine.
15. **DO NOT** touch the engine or the muffler while the engine is running or immediately after stopping. These areas may be hot enough to cause a burn.
16. **DO NOT** run the engine inside a building or a confined area without proper ventilation. Exhaust fumes are hazardous and could cause death.

### 2.5 MAINTENANCE CONSIDERATIONS

1. Never make adjustments to the machine with the engine running unless specifically instructed to do so. If the engine is running, keep hands, feet, and clothing away from moving parts.
2. Remove the key from the ignition switch to prevent accidental starting of the engine when servicing or adjusting the machine.
3. Keep all nuts, bolts and screws tight, to ensure the machine is in safe working condition. Check blade mounting bolts frequently to be sure they are tight.
4. Do not change the engine governor settings or overspeed the engine. See the engine operator's manual for information on engine settings.
5. To reduce fire hazard, keep the engine free of grass, leaves, excessive grease, oil and dirt.
6. **Hydraulic fluid is under high pressure.** Keep body and hands away from pinholes or nozzles that eject hydraulic fluid under high pressure. If you need service on your hydraulic system, please see your authorized Scag dealer.
7. Hydraulic fluid under high pressure may have sufficient force to penetrate skin and cause serious injury. If hydraulic fluid is injected into the skin, it must be surgically removed within a few hours by a doctor or gangrene may result.

## Section 2

### 2.6 SAFETY AND INSTRUCTIONAL DECALS

**DANGER**

**SPINNING BLADE**

KEEP CLEAR

CONTACT CAN INJURE

48071

**WARNING**

**INSTALL BELT COVER BEFORE OPERATING MACHINE**

READ OPERATOR'S MANUAL

481039

**FORWARD**

**F**

**R**

**REVERSE**

481568

**WARNING**

**ROTATING BLADES AND BELTS**

- KEEP HANDS, FEET & CLOTHING CLEAR
- KEEP ALL GUARDS IN PLACE
- SHUT OFF ENGINE & DISENGAGE BLADE CLUTCH BEFORE SERVICING
- CLEAR AREA OF DEBRIS BEFORE MOWING
- USE CAUTION IN DIRECTING DISCHARGE
- KEEP BYSTANDERS, CHILDREN & PETS AWAY
- READ INSTRUCTION MANUAL BEFORE OPERATING

DO NOT OPERATE WITHOUT DISCHARGE CHUTE, MULCHING KIT, OR ENTIRE GRASS CATCHER INSTALLED

481040

**CAUTION**

**AVOID INJURY FROM BURNS. SHUT OFF ENGINE BEFORE REMOVING FUEL TANK CAP.**

481272

**IMPORTANT ADJUSTMENT PROCEDURES**

READ OPERATOR'S MANUAL FOR MORE DETAILS

Check tire pressure-  
(Drive tires - 12 psi,  
Caster tires - 25 psi)

NEUTRAL ADJUSTMENT

Loosen jam nuts

Rotate turnbuckle

With an operator in the seat, engine running, control levers in neutral and the parking brake disengaged - adjust control linkage. Loosen jam nuts. If wheel rotates forward, adjust turnbuckle CCW. If wheel rotates rearward, adjust turnbuckle CW. Adjust until drive wheel stops turning. Tighten jam nuts. Repeat for opposite side.

TRACKING ADJUSTMENT

If the machine pulls to the right, adjust LH control linkage CCW to slow left wheel. If the machine pulls to the left, adjust RH control linkage CCW to slow right wheel. Readjust neutral if necessary.

Gearbox lubricant:  
SAE 80W90 gear oil

**FREE WHEEL OPERATION**

To move machine without running the engine, rotate both dump valve levers located at the LH side of the pumps CCW 1/2 turn to "freewheel" positions. Return levers to original position to operate the mower.

**HYDRAULIC TANK FLUID LEVEL**

Check hydraulic fluid level daily while fluid is cool. Fluid level should be 3-1/4" below top of filler neck. Fill with SAE 20W50 motor oil only.

**IMPORTANT!**  
Do not overfill. Room for hot fluid expansion must be allowed or resulting expansion may cause leaks in the system.

481588

**START / DRIVE PROCEDURE**

- ENGAGE PARKING BRAKE
- DISENGAGE MOWER DECK DRIVE
- MOVE CONTROL HANDLES TO NEUTRAL LOCK POSITION
- START ENGINE
- RELEASE PARKING BRAKE
- SELECT FORWARD OR REVERSE SPEED WITH HYDRO CONTROL HANDLES

**CAUTION**

KEEP BYSTANDERS AWAY

**CAUTION**

**BEFORE OPERATING READ OPERATOR'S MANUAL AND SAFETY INSTRUCTIONS**

481567

### SPECIFICATIONS

#### 3.1 ENGINE

General Type .....	Heavy Duty Industrial/Commercial Gasoline
Brand .....	Kohler, 22HP (Spec. #PS-76510) 25HP (Spec. #PS-68579) Kawasaki, 22HP (Spec. # FD661D-AS0201)
Model .....	Kohler Command, Kawasaki FD661D
Horsepower .....	22 HP at 3600 RPM (Model STT52&52b-22CH, STT61&61B-22CH) 25 HP at 3600 RPM (Model STT52&52B-25CH, STT61&61B-25CH) 22 HP at 3600 RPM (Model STT52&52B-22KA, STT61&61B-22KA)
Type .....	4 Cycle Gasoline, Twin Cylinder, Horizontal Shaft
Displacement .....	22HP Kohler 674 cc., 25HP Kohler 725cc., 22HP Kawasaki 617cc
Cylinders .....	2 with Cast Iron Sleeves
Governor .....	Mechanical Type with Variable Speed Control Set At 3600 RPM
Idle Speed .....	1400 RPM
Kohler Fuel Pump Group .....	Mechanical Type Fuel Pump with In-Line Fuel Filter, Fixed Jet Carburetor with Smart-Choke™ and Fuel Shutdown Solenoid
Kawasaki Fuel Pump Group .....	Electric Fuel Pump with In-Line Fuel Filter, Fixed Jet Downdraft Carburetor.
Fuel .....	Non-Leaded Gasoline with a Minimum Octane Rating of 87
Oil Pump Group .....	Positive Displacement Gerotor™ Oil Pump with Remote Oil Filter
Starter .....	Electric Starting with Solenoid Shift Starter
Belts: .....	Kevlar cord. Self-adjusting, Self-tightening
Deck Drive Belt .....	Scag Part Number - 481460
Pump Drive Belt .....	Scag Part Number - 481461
Kawasaki Fan Belt .....	Part Number - Mitsubishi 59011-2056 (N/A Through Scag)

#### 3.2 ELECTRICAL

Battery .....	12 Volt
Charging System .....	Alternator
Charging Output .....	12 Volt, 15 Amp
System Polarity .....	Negative Ground
Starter .....	12 Volt Electric Ring Gear Type, Key and Solenoid Operated
Interlock Switches .....	Seat, Neutral Control, Mower Engagement (BBC), Parking Brake
Instrument Panel .....	Ammeter, Hourmeter, Key Switch, Throttle Lever, Manual Choke, BBC Switch, Fuses and Safety Start module, Temp. gauge (KA)
Fuses .....	Two (2) 20 Amp

#### 3.3 TRACTOR

Drive System .....	Hydraulic Drive with Two Variable Displacement Pumps and Two Cast-iron High Torque Motors
Hydrostatic Pumps .....	Two Hydro-Gear™ BDP 10L Pumps with Dump Valves for movement without running the engine
Drive Wheel Motors .....	Two Ross Model MB 15 cu. inch Cast-iron High Torque Motors
Steering/Travel Control .....	Twin Lever Fingertip Steering Control with Individual Control to Each Wheel with Gas Spring Dampers
Parking Brake .....	Lever Actuated Linkage to Brakes on Both Drive Wheel Axles
Wheels:	
(2) Front Caster .....	13 X 5.00 Four-Ply
(2) Drive .....	23 X 10.5 X 12 Four-Ply Pneumatic Tubeless, Radius Edge, 52" 24X12.0X12.0 Four-Ply Pneumatic Tubeless, Radius Edge, 61"
Fuel Tank .....	10-Gallon Seamless Polyethylene Tank with Fuel Gauge Fill Cap
Tire Pressure:	
Front Caster .....	25 PSI
Drive .....	12 PSI
Seat .....	Padded, Thick Cushion with Extra Spring Support



## Section 3

### 3.3 TRACTOR (CONT'D)

**-NOTE-**

Travel Speed:	
Forward .....	0-10 MPH
Reverse .....	0-5 MPH

*The machine will travel at 10mph for transport purposes. For best cutting performance the forward travel speed should be adjusted depending upon the cutting conditions.*

### 3.4 CUTTER DECK

Type: .....	Floating, Adjustable, Anti-scalping, Hybrid Design Combines Out-front and Belly-mount Designs
Construction: .....	10-gauge steel reinforced with 7-gauge (3/16") Support Plate. 7-gauge (3/16") deck skirt with 3/8" front plate.
True Cutting Width: .....	52" (132.0 cm), 61: (155.0 cm)
Cutting Height Adjustment: .....	Foot Operated Lever Adjustment from Operator's Seat, 1.00" to 6.00" in 1/2"increments
Cutter Blades: .....	204 Thick, Milled Edge, 5150 Alloy Steel SMT 52: Three (3) 18" blades SMT 61: Three (3) 21" blades
Blade Engagement: .....	Electric Blade Engagement Clutch with Control Panel Switch Connected to the Cutter Deck Gearbox through a Drive Shaft.
Discharge Opening: .....	Extra Wide 11.5" Discharge Opening with Spring Loaded Discharge Chute
Caster Wheels: .....	13x 5.00 Four-Ply
Spindles: .....	Heavy-duty 1-1/8" Top Dimension Spindle Shaft, Cast Housing, Taper Roller Bearing, Low Maintenance with Top Access Grease Fitting and Grease Overfill Relief Poppet
Spindle Pulleys: .....	Cast-iron with Easily Removed Taper Hubs
Cutter Deck Belts: .....	B-section with Kevlar Cord. Self-adjusting, Self-tightening
SMT52 .....	Scag Part Number - 481557
SMT61 .....	Scag Part Number - 481558
Electric Clutch Type .....	Warner "Mag Stop" Electric Clutch
Drive Shaft .....	Quick-disconnect Shaft With Two High Speed U-Joints

### 3.6 HYDRAULIC SYSTEM

Hydraulic Oil Filter .....	10 Micron Spin-on Element Type
Hydraulic Reservoir .....	Nylon; 6 Quart Capacity

### 3.7 WEIGHTS AND DIMENSIONS

	<b>52" MODEL</b>	<b>61" MODEL</b>
Length .....	76"	79"
Tracking Width .....	51"	51"
Overall Width .....	62"	72"
Overall Height .....	30"	30"
Operating Weight .....	1160#	1200#

### 3.8 PRODUCTIVITY

The following chart will aid you in determining how many acres your Scag mower will cut per day.

The chart is an estimate based on 8 hours per day cutting time at 4 MPH with an allowance for overlap and turns.

<b>Cutting Width:</b>	36"	48"	52"	61"	72"
<b>Acres Per Day:</b>	9.5	12.5	13.5	16	19



### OPERATING INSTRUCTIONS

#### **CAUTION:**

Do not attempt to operate this mower unless you have read this manual. Learn the location and purpose of all controls and instruments before you operate this mower.

#### 4.1 CONTROLS AND INSTRUMENT IDENTIFICATION

Before operating the mower, familiarize yourself with all mower and engine controls. Knowing the location, function and operation of these controls is important for safe and efficient operation of the mower.

- 1. Ignition Switch (Figure 4-1).** The ignition switch is used to start the engine and has three positions; OFF, ON, and START.
- 2. Mower Deck Switch (Figure 4-1).** Used to engage and disengage the mower drive system. Pulling up on the switch will engage the deck drive. Pushing down on the switch will disengage the deck drive.
- 3. Engine Choke Control (Figure 4-1).** Used to start a cold engine.
- 4. Engine Throttle Control (Figure 4-1).** Used to control the engine speed. Pushing the lever forward increases engine speed. Pulling the lever back decreases engine speed. Full back position is the IDLE position. Full forward is the cutting position.

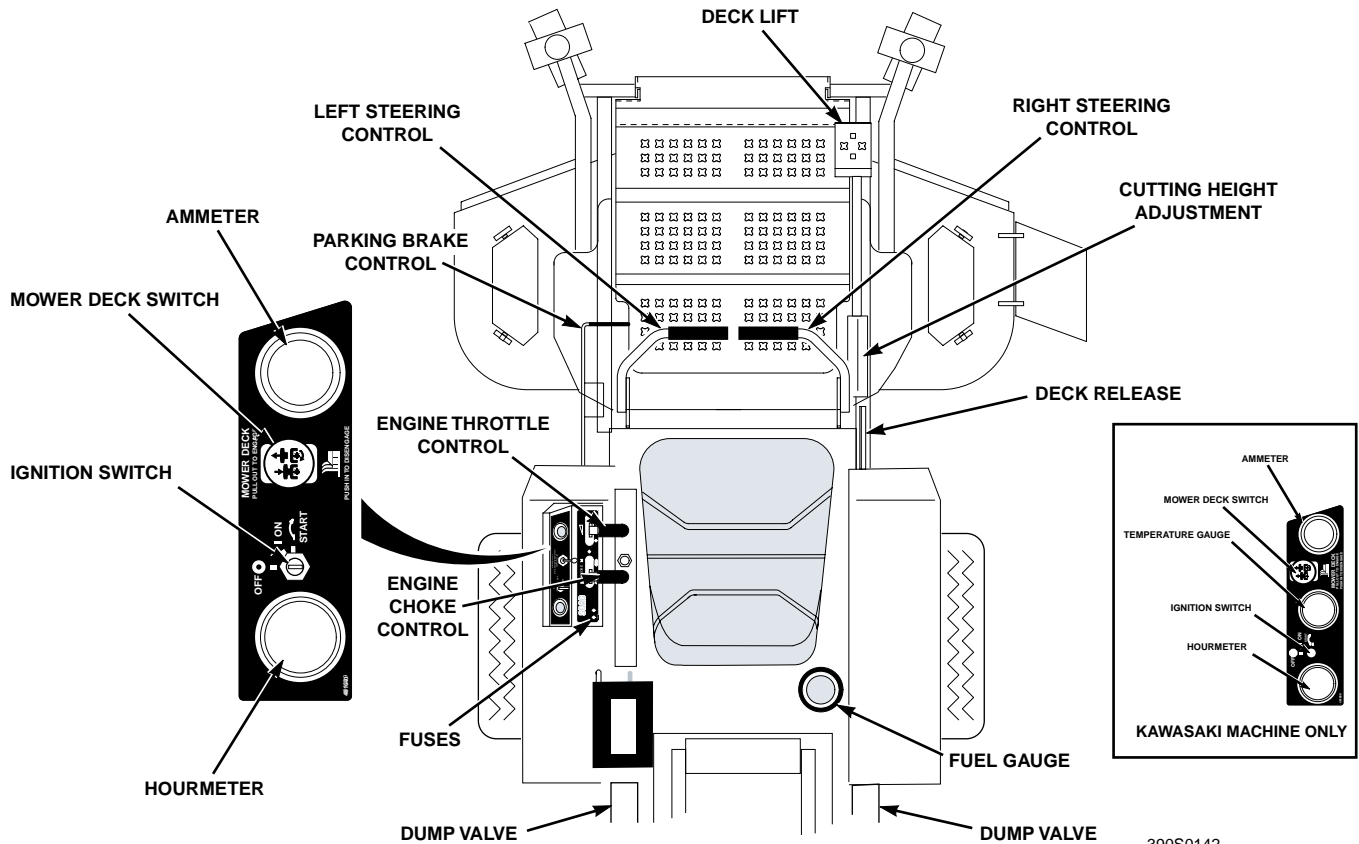
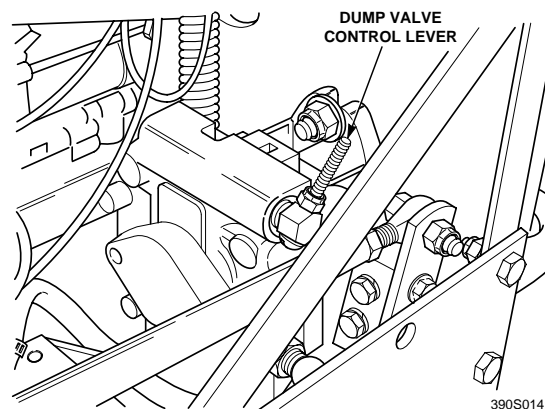

Figure 4-1 Controls and Instruments

## Section 4

5. **Ammeter (Figure 4-1).** Indicates the condition of the charging system. When the engine is running the needle should be toward the positive end of the meter. If the needle is toward the negative end of the meter, this indicates a discharge condition and the machine should be taken in for service.
6. **Hourmeter (Figure 4-1).** Indicates the number of hours the engine has been operated. It operates whenever the ignition key switch is in the ON position. It can be used to keep track of maintenance intervals and the amount of time required to perform various tasks.
7. **Fuse Holders (Figure 4-1).** Two 20-amp fuses protect the mower's electrical system. To replace fuses, pull fuse out of the socket and install a new fuse.
8. **Left Steering Control (Figure 4-1).** Used to control the mower's left wheel when traveling forward or reverse.
9. **Right Steering Control (Figure 4-1).** Used to control the mower's right wheel when traveling forward or reverse.
10. **Parking Brake Control (Figure 4-1).** Used to engage and disengage the parking brakes. Pull the lever back to engage the parking brakes. Push the lever forward to disengage the parking brakes.
11. **Fuel Tank Gauge (Figure 4-1).** Indicates the amount of fuel in the fuel tank.
12. **Dump Valve Control Levers (Figure 4-2).** Located on the hydraulic pumps, used to "free-wheel" the mower. Rotating the levers clockwise until they stop allows the unit to move under hydraulic power. The levers must be in this position during operation of the mower. Rotating the levers counter-clockwise allows the mower to be moved by hand (free-wheeling).
13. **Deck Lift Foot Lever (Figure 4-1).** Used to raise and lower the cutter deck.
14. **Cutting Height Adjustment (Figure 4-1).** Used to set the cutter deck at the desired cutting height.



**Figure 4-2 Dump Valve Control**

15. **Deck Release Lever (Figure 4-1).** Used to lock the cutter deck in the transport position. Push the foot pedal forward and lift up on the release lever to release the cutter deck for normal mowing.
16. **Temperature Gauge (Figure 4-1).** Indicates the operating temperature of the engine. *Used on the Kawasaki liquid cooled engine only.*

### 4.2 SAFETY INTERLOCK SYSTEM

The mower is equipped with a safety interlock system that prevents the engine from starting unless the deck drive is disengaged, the parking brake is engaged, the steering control levers are in the neutral position and the operator is in the seat. The interlock system shuts off the engine if the operator leaves the seat with the steering control levers not in the neutral position and/or the cutter blades engaged and the parking brake not engaged.

#### **WARNING:**

**Never operate the mower with the interlock system disconnected or malfunctioning. Do not disengage or bypass any switch; injury to yourself and others or property damage could result.**

### 4.3 INITIAL RUN-IN PROCEDURES (First Day of Use or Approximately 10 Hours)

1. Check all belts for proper alignment and wear at 2, 4 and 8 hours.

2. Change the engine oil and oil filter after the first 5 hours of operation. (See Section 7.4.)
3. Check hydraulic oil level in reservoir. (See Section 7.3.)
4. Check for loose hardware. Tighten as needed.
5. Check interlock system for proper operation. (See Section 4.2.)
6. Check tire pressure. Adjust pressure if necessary. (See Section 7.10)

### 4.4 STARTING THE ENGINE



## CAUTION:

**DO NOT USE STARTING FLUIDS.** Use of starting fluids in the air intake system may be potentially explosive or cause a "runaway" engine condition that could result in engine damage and/or personal injury.

1. Be sure the fuel shutoff valve, located behind the operator's seat, is completely open. (See section 7.5.)
2. Sit in the operator's seat and place the steering control levers in the neutral position.
3. Engage the parking brake.
4. If the engine is cold, choke the engine as needed.
5. Move the engine throttle control to about half engine speed.
6. Turn the ignition key to the START position and release the key as soon as the engine starts. Do not hold the key in the START position for more than 15 seconds at a time. Allow at least 60 seconds between each cranking attempt to prevent overheating of the starter motor. Prolonged cranking can damage the starter motor and shorten battery life.
7. Allow engine to warm before operating the mower.

### 4.5 GROUND TRAVEL AND STEERING

#### -IMPORTANT-

*If you are not familiar with the operation of a machine with lever steering and/or hydrostatic transmissions, the steering and ground speed operations should be learned and practiced in an open area, away from buildings, fences, or obstructions. Practice until you are comfortable with the handling of the machine before attempting to mow. Learn the operation on flat ground before operating on slopes.*

#### -IMPORTANT-

*Start practicing with a slow engine speed and slow forward travel.*

*Learn to feather the steering controls to obtain a smooth operating action.*

*Practice operating the mower until you are comfortable with the controls before proceeding to mow.*

#### Forward Travel

To travel forward with the mower, disengage the parking brake and slowly push the steering control levers forward an equal distance. The further the steering control levers are pushed forward the greater the forward speed will be. To increase the speed, push the steering control levers further forward and to decrease the speed, pull the steering control levers back.

To stop the forward travel, pull the steering control levers back to the neutral position.

To steer the mower left while traveling forward, pull the left steering lever back. The further the lever is pulled back, the quicker the mower will turn left.

To steer the mower right while traveling forward, pull the right steering control lever back. The further the lever is pulled back, the quicker the mower will turn right.

## Section 4

### -NOTE-

Smooth operation of the steering levers will produce smooth mower operation. While learning the operation of the steering controls, keep the travel speed low.

### -IMPORTANT-

Do not travel forward over a curb. The mower will hang up on the curb. Raise the deck and travel backwards over the curb at a 45 degree angle. (see section 4.13 for cutter deck raising instructions)

## Reverse Travel

### CAUTION:

Disengage power to the mower before backing up. Do not mow in reverse unless absolutely necessary and then only after observation of the entire area behind the mower.

### CAUTION:

Before backing up, observe the rear for persons and obstructions. Clear the area before backing up. Possible injury or property damage could occur.

To travel in reverse, pull both handles back. Keep the travel speed low while traveling in reverse.

### -NOTE-

The mower will not travel straight in reverse. Slight adjustments must be made using the steering controls.

To steer left while traveling in reverse, allow the left steering control lever to move forward. The further the control is allowed to move forward, the quicker the mower will turn left.

To steer right while traveling in reverse, allow the right steering control lever to move forward. The further the control is allowed to move forward, the quicker the mower will turn right.

To stop the reverse travel, allow the steering control levers to return to the neutral position. If the mower is to be parked, engage the parking brake.

## 4.6 ENGAGING THE DECK DRIVE (CUTTER BLADES)

1. Set the throttle at about 3/4 speed. Do not attempt to engage the deck drive at high speed as this shortens the electric clutch life — use only moderate engine speed when engaging the deck drive.
2. Engage the deck drive by pulling up on the yellow switch, located on the instrument panel, (Figure 4-3) to the engage position.

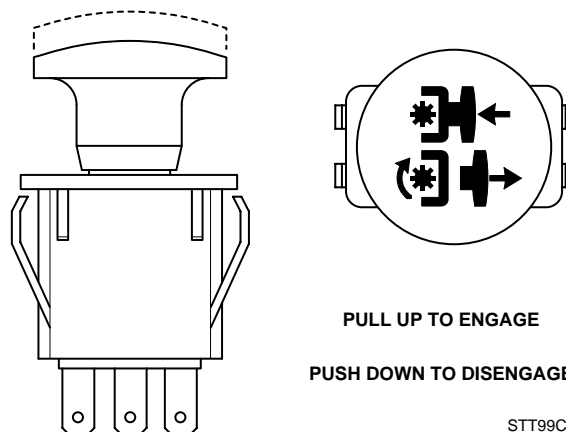

Figure 4-3 Cutter Engage Switch

### -NOTE-

A squealing noise may be heard when engaging or disengaging the deck drive. It is caused by the electric clutch plates meshing as the mower comes up to speed.

3. To disengage the deck drive, push the switch in to the disengage position.
4. Always operate the engine at full throttle to properly maintain cutting speed. If the engine starts to lug down, reduce the forward speed and allow the engine to operate at maximum RPM.

### 4.7 HILLSIDE OPERATION

#### **WARNING:**

**DO NOT operate on steep slopes. To check a slope, attempt to back up it (with the cutter deck down). If the machine can back up the slope without the wheels slipping, reduce speed and use extreme caution. ALWAYS FOLLOW OSHA APPROVED OPERATION.**

1. The mower has been designed for good traction and stability under normal mowing conditions. However, caution must be used when traveling on slopes, especially when the grass is wet. Wet grass reduces traction and steering control.
2. To prevent tipping or loss of control, do not start or stop suddenly, avoid unnecessary turns and travel at reduced speed.
3. Keep tires properly inflated.

### 4.8 PARKING THE MOWER

1. Place the steering control levers in the neutral position.
2. Disengage the cutter blades
3. Slow the engine to idle speed.
4. Engage the parking brake.
5. Turn the ignition key to the OFF position and remove the key.

### 4.9 AFTER OPERATION

1. Wash the entire mower after each use. Do not use high pressure spray or direct the spray onto electrical components.

#### **-IMPORTANT-**

*Do not wash a hot or running engine. Cold water will damage the engine. Use compressed air to clean the engine if it is hot.*

2. Keep the entire mower clean to inhibit serious heat damage to the engine or hydraulic oil circuit.
3. Check the drive belts for proper alignment and any signs of wear. Correct and adjust if necessary.

#### **DANGER:**

**To avoid injury from burns, allow the mower to cool before removing the fuel tank cap and refueling.**

4. After the mower has cooled down, fill the fuel tank with fresh, clean fuel at the end of every day of operation.
5. Check the tire pressure. Adjust pressure if necessary.

## Section 4

### 4.10 REMOVING CLOGGED MATERIAL

 **DANGER:**  
**ROTATING BLADES**

**NEVER PUT YOUR HANDS INTO THE DISCHARGE CHUTE FOR ANY REASON! Shut off the engine and remove the key and only then use a stick or similar object to remove material if clogging has occurred.**

1. If the discharge chute becomes clogged, shut off the engine and remove the ignition key. Using a stick or similar item, dislodge the clogged material. Then resume normal mowing.
5. When mowing wet or tall grass, mow the grass twice. Raise the mower to the highest setting for the first pass and then make a second pass to the desired height.
6. Use a slow travel speed for trimming purposes.
7. Operate the engine at full throttle for best cutting. Mowing with a lower RPM causes the mower to tear the grass. The engine is designed to be operated at full speed.
8. Use the alternate stripe pattern for best lawn appearance. Vary the direction of the stripe each time the grass is mowed to avoid wear patterns in the grass.

### 4.11 MOVING MOWER WITH ENGINE STOPPED

To “free-wheel” or move the mower around without the engine running, place the dump valve levers in the FREE-WHEEL position (Figure 4-2). Disengage the parking brake and move the mower by hand. The dump valve levers must be returned to the DRIVE position to drive the mower.

### 4.12 RECOMMENDATIONS FOR MOWING

1. Do not mow with dull blades. A dull blade will tear grass, resulting in poor lawn appearance and require extra power.
2. The discharge chute must not be removed and must be kept in the lowest position to deflect grass clippings and thrown objects downward. Direct the side discharge away from sidewalks or streets to minimize cleanup of clippings. When mowing close to obstacles, direct the discharge away from the obstacles to reduce the chance of property damage by thrown objects.
3. Cut grass when it is dry and not too tall. Do not cut grass too short (cut off 1/3 or less of existing grass for best appearance). Mow frequently.
4. Keep mower and discharge chute clean.



### 4.13 ADJUSTING CUTTING HEIGHT

The mower deck can be adjusted from a height of 1-inch to 6 inches at 1/2-inch intervals. To adjust the cutting height:

#### **WARNING:**

**Do not adjust the cutting height with the mower blades rotating. Disengage the power to the cutter blades and then adjust cutting height.**

1. Disengage the power to the cutter blades.
2. Push the cutting height adjustment foot pedal all the way forward using your right foot until it locks in place. (Figure 4-6).
3. Insert the lanyard pin into the cutting height index at the desired cutting height. Push forward on the deck lift foot lever, hold in place and lift up on the deck release lever, (Figure 4-7). Slowly release the foot pedal. A deck height decal is located on the cutting height index as an aid in adjusting the deck to the desired height. (Figure 4-6).

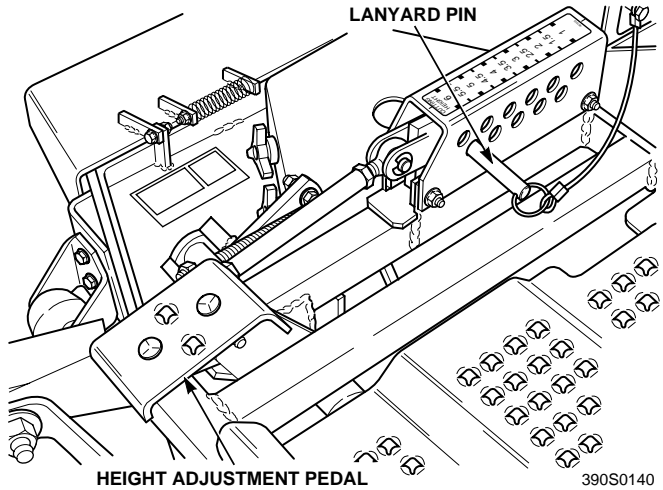

**Figure 4-6 Adjusting Cutting Height**

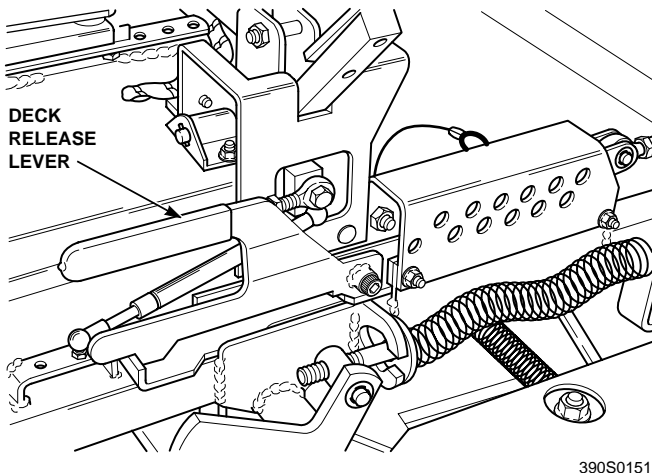
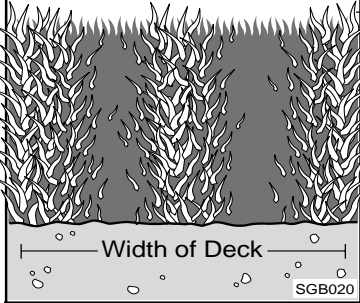
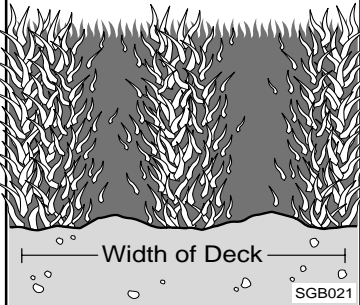
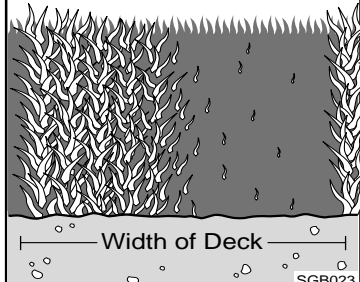

**Figure 4-7 Deck Release Lever**

## TROUBLESHOOTING CUTTING CONDITIONS

CONDITION	CAUSE	CURE
<p><b>Stringers - Occasional Blades of Uncut Grass</b></p> <p style="text-align: right; font-size: small;">SGB020</p>	Low engine RPM	Run engine at full RPM
	Ground speed too fast	Slow speed to adjust for conditions
	Wet grass	Cut grass after it has dried out
	Dull blades, incorrect sharpening	Sharpen blades
	Deck plugged, grass accumulation	Clean underside of deck
	Belts slipping	Adjust belt tension
<p><b>Streaking - Strips of Uncut Grass in Cutting Path</b></p> <p style="text-align: right; font-size: small;">SGB018</p>	Dull, worn blades	Sharpen blades
	Incorrect blade sharpening	Sharpen blades
	Low engine RPM	Run engine at full RPM
	Belt slipping	Adjust belt tension
	Deck plugged, grass accumulation	Clean underside of deck
	Ground speed too fast	Slow speed to adjust for conditions
	Wet grass	Cut grass after it has dried out
	Bent blades	Replace blades
<p><b>Streaking - Strips of Uncut Grass Between Cutting Paths</b></p> <p style="text-align: center; font-size: small;">SGB019</p>	Not enough overlapping between rows	Increase the overlap of each pass

### TROUBLESHOOTING (CONT'D)

CONDITION	CAUSE	CURE
<p><b>Uneven Cut on Flat Ground - Wavy High-Low Appearance, Scalloped Cut, or Rough Contour</b></p>  <p>Width of Deck SGB020</p>	Lift worn from blade	Replace blade
	Blade upside down	Mount with cutting edge toward ground
	Deck plugged, grass accumulation	Clean underside of deck
	Too much blade angle (deck pitch)	Adjust pitch and level
	Deck mounted improperly	See your authorized SCAG dealer
	Bent spindle area	See your authorized SCAG dealer
	Dull blade	Sharpen blade
<p><b>Uneven Cut on Uneven Ground - Wavy Appearance, High-Low Scalloped Cut, or Rough Contour</b></p>  <p>Width of Deck SGB021</p>	Uneven ground	May need to reduce ground speed, raise cutting height, and/or change direction of cut
<p><b>Sloping Ridge Across Width of Cutting Path</b></p>  <p>Width of Deck SGB023</p>	Tire pressures not equal	Check and adjust tire pressure
	Wheels uneven	Check and adjust tire pressure
	Deck mounted incorrectly	See your authorized SCAG dealer
	Deck not level side-to-side	Check for level and correct

**TROUBLESHOOTING (CONT'D)**

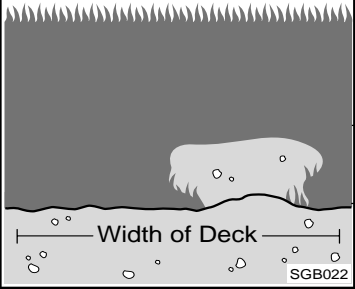
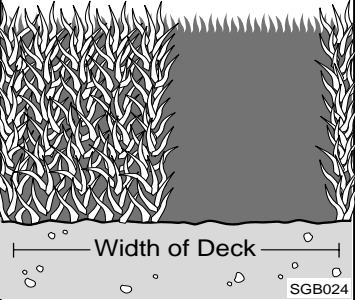
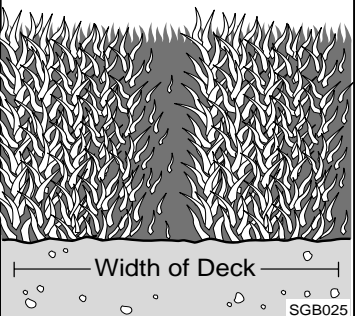
CONDITION	CAUSE	CURE
<p><b>Scalping - Blades Hitting Dirt or Cutting Very Close to the Ground</b></p>  <p>Width of Deck SGB022</p>	Low tire pressures	Check and adjust pressures
	Round speed too fast	Slow speed to adjust for conditions
	Cutting too low	May need to reduce ground speed, raise cutting height, change direction of cut, and/or change pitch and level
	Rough terrain	May need to reduce ground speed, raise cutting height, and/or change direction of cut
	Ground speed too fast	Slow speed to adjust for conditions
<p><b>Step Cut - Ridge in Center of Cutting path</b></p>  <p>Width of Deck SGB024</p>	Blades not mounted evenly	Adjust pitch and level
	Bent blade	Replace blade
	Internal spindle failure	See your authorized SCAG dealer
	Mounting of spindle incorrect	See your authorized SCAG dealer
<p><b>Slope Cut - Sloping Ridges Across Width of Cutting Path</b></p>  <p>Width of Deck SGB025</p>	Bent spindle mounting area	See your authorized SCAG dealer
	Internal spindle failure	See your authorized SCAG dealer
	Bent deck housing	See your authorized SCAG dealer

### ADJUSTMENTS

#### 6.1 PARKING BRAKE ADJUSTMENT

#### **! WARNING:**

Do not operate the mower if the parking brake is not operable. Possible severe injury could result.

The parking brake linkage should be adjusted whenever the parking brake lever is placed in the "ENGAGE" position and the parking brake will not prevent the mower from moving. If the following procedures do not allow you to engage the parking brake properly, contact your Scag dealer for further brake adjustments.

1. Position a floor jack under the rear of the machine. Raise the machine and support it to prevent it from falling. Block the caster wheels to prevent the machine from moving. Remove the drive wheels.
2. With the brake lever in the disengaged position, check the distance between the top of the frame tube and the bottom of the brake handle. The distance should be 2" to 2-1/4" (See Figure 6-1).
3. If the distance is not at the specified measurement, adjust by loosening the jam nuts at both ends of the brake control rod and turning the rod until the proper distance is achieved. (See Figure 6-1). Tighten the jam nuts.
4. With the brake in the engaged position, check the distance between the lower nut on the brake actuator rod and the brake actuator lever on the LH side of the machine. The distance should be 1/8" (See Figure 6-2).
5. If the distance is not at the specified measurement, loosen the jam nut at the clevis on the top of the brake actuator rod (See Figure 6-2).
6. Turn the bolt at the bottom of the brake actuator lever until the 1/8" measurement is achieved and tighten the jam nut at the clevis on the brake actuator rod. (See Figure 6-2).

7. Repeat steps 4-6 on the RH side of the machine.
8. Replace the drive wheels and test the brake.

**-NOTE-**

If this procedure does not achieve proper brake adjustment, please contact your authorized Scag dealer.

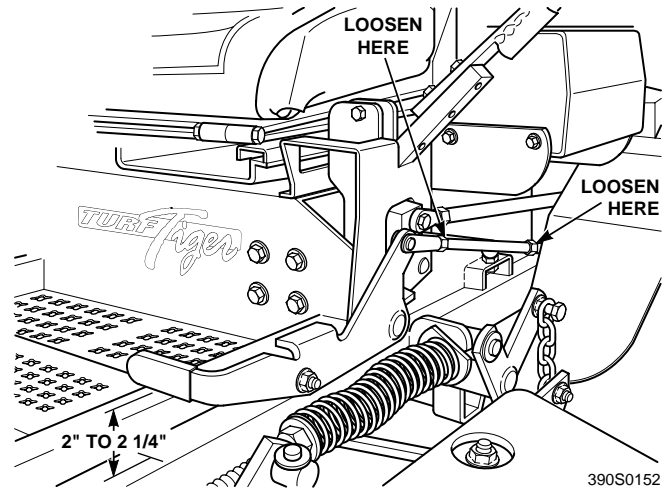

**Figure 6-1. Brake Adjustment**

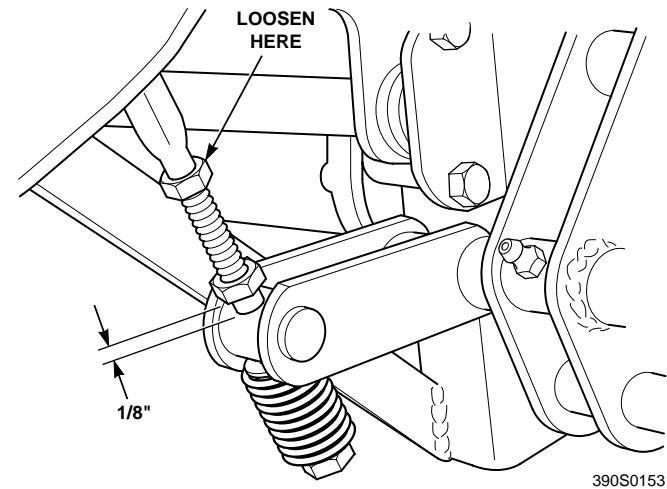

**Figure 6-2. Brake Rod Adjustment**

#### 6.2 TRAVEL ADJUSTMENTS

Neutral or tracking adjustments will need to be made if:

- A. The steering control levers are in the neutral position and the machine creeps forward or backward. (Neutral Adjustment, See Page 19).

## Section 6

- B. The steering control levers are in the full forward position and the mower pulls to one side or the other when traveling in a forward direction. (Tracking Adjustment, See Page 20).

### Neutral Adjustment

1. Be sure the dump valve levers are in the run position and the steering control levers are in the neutral lock position.
2. With an operator in the seat, start the engine and disengage the parking brake.
3. Run the engine at full operating speed and check if the machine creeps forward or backwards.
4. Adjust the RH wheel by loosening the jam nuts on the steering control rod and turning the rod until the drive wheel turns in the forward direction. Turn the rod back until the drive wheel stops moving. Turn the rod an additional 1/2 turn. (See Figure 6-3).
5. Tighten the jam nuts and repeat for the LH wheel. (See Figure 6-4).
6. Actuate the steering control levers forward and reverse several times and return them to the neutral position.
7. Check that the drive wheels remained in neutral and readjust if necessary.
8. Check that the steering control levers hit the stop before the pumps reach full stroke. Adjust as needed.

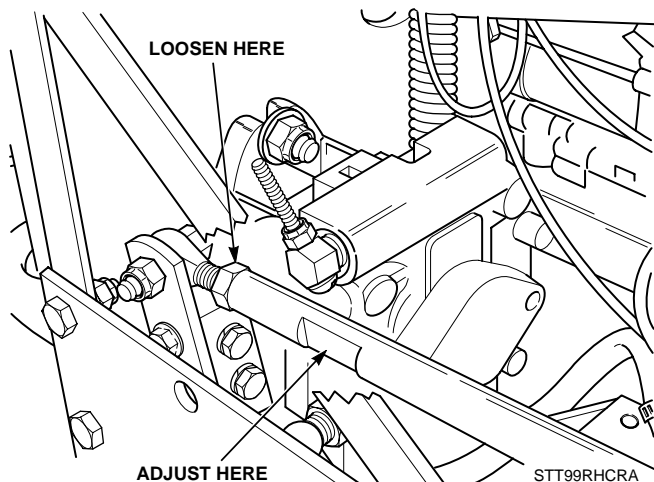
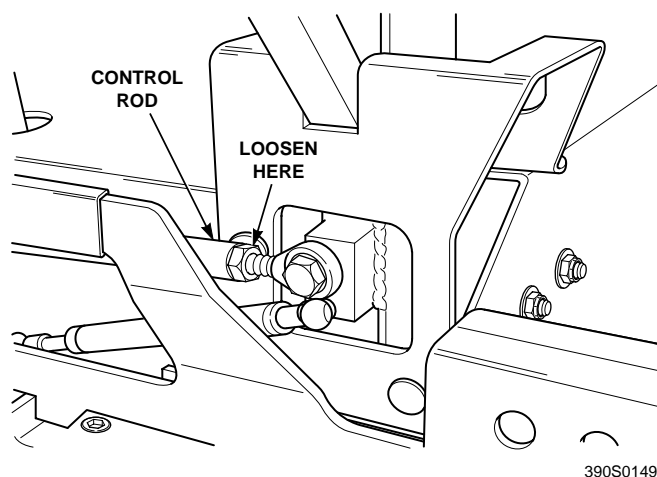

Figure 6-3. RH Steering Control Rod Adjustment

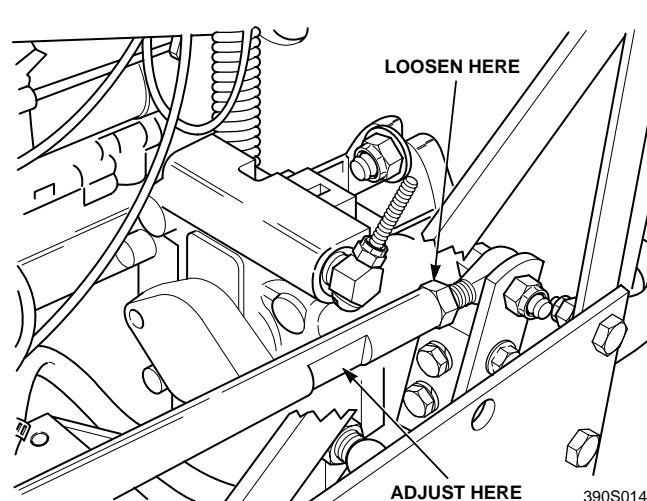
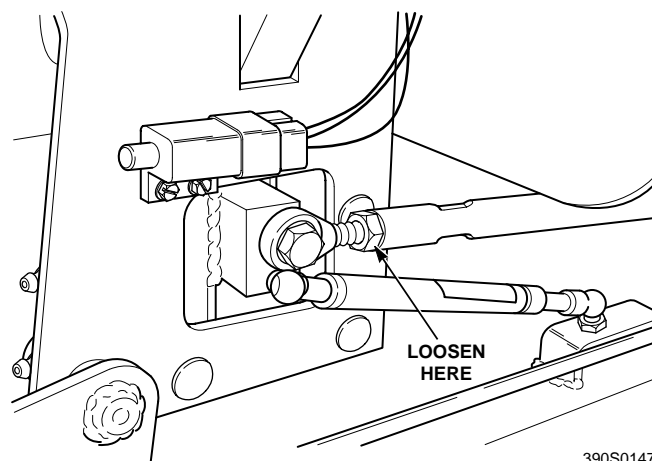

Figure 6-4. LH Steering Control Rod Adjustment

### Tracking Adjustment

#### CAUTION:

Stop the engine and remove the key from the ignition before making any adjustments. Wait for all moving parts to come to a complete stop before beginning work.

#### CAUTION:

The engine and drive unit can get hot during operation causing burn injuries. Allow engine and drive components to cool before making any adjustments.

#### -NOTE-

*Before proceeding with this adjustment, be sure that the caster wheels turn freely and that the tire pressure in the drive wheels is correct. If the tire pressure is not correct, the machine will pull to the side with the lower pressure.*

1. If at full speed the mower pulls right, it is an indication that the left wheel is turning faster than the right wheel. To adjust this condition, proceed as follows:
  - A. Stop the machine and place the steering control levers in the neutral position. Loosen the lock nuts securing the ball joints at each end of the LH steering control rod. Rotate the control rod to lengthen the rod and tighten the lock nuts. This will cause the control rod to stroke the LH pump less, slowing down the LH wheel. (See Figure 6-4)

#### -NOTE-

*If after making the adjustment as outlined in step 1A, the machine creeps forward or backward, the neutral adjustment must be made as described on page 19.*

2. If at full speed the mower pulls left, it is an indication that the right wheel is turning faster than the left wheel. To adjust this condition, proceed as follows:

- A. Stop the machine and place the steering control levers in the neutral position. Loosen the lock nuts securing the ball joints at each end of the RH steering control rod. Rotate the control rod to lengthen the rod and tighten the lock nuts. This will cause the control rod to stroke the RH pump less, slowing down the RH wheel. (See Figure 6-3)

#### -NOTE-

*If after making the adjustment as outlined in step 2A, the machine creeps forward or backward, the neutral adjustment must be made as described on page 19.*

### 6.3 THROTTLE CONTROL AND CHOKE ADJUSTMENTS

These adjustments must be performed by your Scag dealer to ensure proper and efficient running of the engine. Should either need adjustment, contact your authorized Scag service center.

### 6.4 BELT ADJUSTMENT

#### WARNING:

**Before removing any guards, shut the engine off and remove the ignition key.**

All drive belts and cutter deck belts are spring loaded and self-tensioning. The belts should be checked periodically for proper alignment and wear.

### 6.5 BELT ALIGNMENT

Belt alignment is important for proper performance of your Scag mower. If you experience frequent belt wear or breakage, see your authorized Scag service center for belt adjustment.

## Section 6

### 6.6 CUTTER DECK ADJUSTMENTS

Cutter deck level, pitch and height are set at the factory. However, if these adjustments should ever need to be made, the following procedures will aid in obtaining the proper cutter deck adjustment.

**-NOTE-**

*Before proceeding with the cutter deck adjustments, be sure that all tires are properly inflated.*

#### Cutter Deck Level

The cutter deck should be level from side-to-side for proper cutting performance. To check for level, be sure that the mower is on a flat, level surface, the tires are properly inflated and the cutter deck is set at the most common cutting height that you will use. On the RH side of the machine, check the distance from the bottom of the cutter deck to the floor. Next check the distance from the bottom of the cutter deck to the floor on the LH side of the machine. Both measurements should be the same. If the two measurements are different, the cutter deck level must be adjusted as follows:

1. On the front LH side of the cutter deck locate the cutter deck adjusting bolt. (See Figure 6.5)

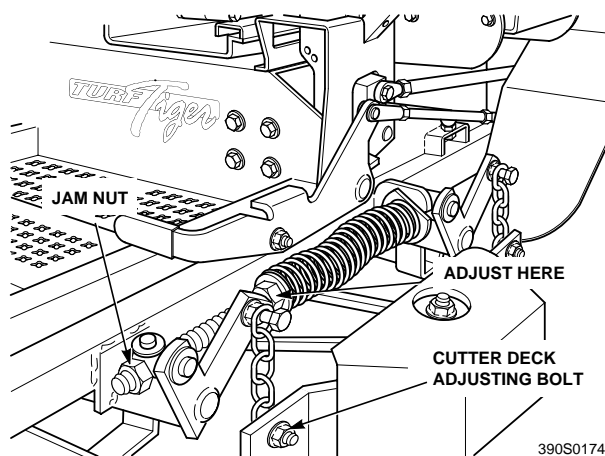

**Figure 6-5. Cutter Deck Adjustment**

2. Loosen the serrated flange hex nut and move the bolt up or down in the slot to adjust the cutter deck until the distance from the bottom of the cutter deck to the floor is the same as the measurement on the RH side of the machine.

3. Tighten the serrated hex nut to secure the cutter deck in the proper position.

#### Cutter Deck Pitch

The pitch of the cutter deck should be 1/4" down toward the front of the cutter deck for proper cutting performance. To check for proper deck pitch, be sure that the mower is on a flat, level surface and the tires are properly inflated.

Check the distance from the bottom of the cutter deck to the floor at the rear RH side of the cutter deck directly behind the cutter deck hanging chains. Next check the distance from the bottom of the cutter deck to the floor at the front RH side of the cutter deck directly in front of the cutter deck hanging chains. The measurement at the front of the cutter deck should be 1/4" lower than the measurement at the rear of the deck. Make these measurements at the LH side of the cutter deck also. If the measurement at the front of the deck is not 1/4" lower, the cutter deck pitch must be adjusted as follows:

1. Loosen the jam nuts on both adjusting rods. (See Figure 6.5)
2. Using a wrench on the spring compression nut (See Figure 6.5) turn the adjusting rods until the 1/4" forward pitch is obtained on both the RH and the LH side of the cutter deck. Tighten both jam nuts.

**-NOTE-**

*To prevent the cutter deck from teetering, all four cutter deck hanging chains must have tension on them. If all four chains do not have tension on them and the deck teeters, you must readjust the cutter deck as outlined in the procedures above.*



### Cutter Deck Height

The cutter deck height adjustment is made to ensure that the cutter deck is cutting at the height indicated on the cutting height index gauge. To check for proper deck height, be sure that the mower is on a flat, level surface and the tires are properly inflated.

1. Place the cutter deck in the transport position. Loosen the jam nuts on both ends of the deck height control rod. (See Figure 6.6)

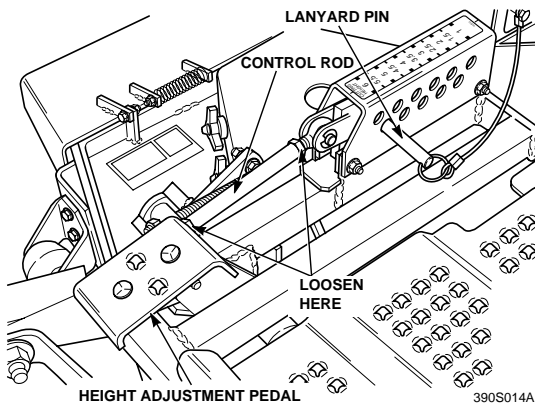

**Figure 6-6. Cutter Deck Height Adjustment**

2. Turn the control rod (See Figure 6.6) until there is a 1/4" space between the rear deck stop and the top of the cutter deck. (See Figure 6.7). Tighten the jam nuts on the control rod.

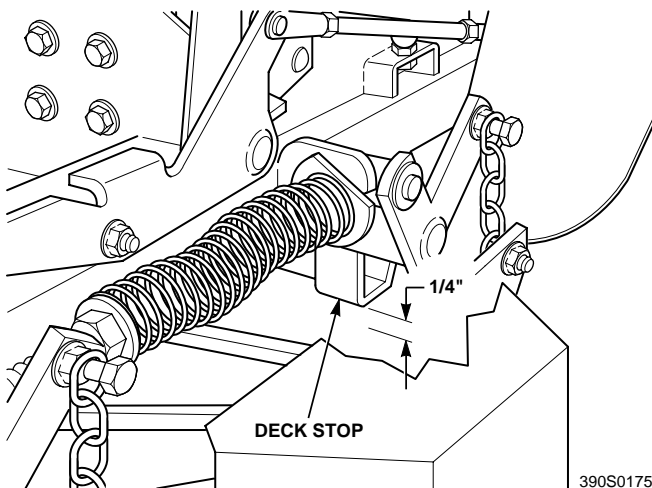

**Figure 6-7. Cutter Deck Stop**

3. Check the cutter deck cutting height by placing the lanyard pin in the 3" position on the cutting height index. Release the deck from the transport position and allow the deck to move to the 3" cutting height position.
4. Check the measurement from the floor to the cutter blade tip. If the measurement is not at 3", an adjustment can be made using the deck height control rod. (See Figure 6.6)

**-NOTE-**

*If an adjustment had to be made, be sure that the cutter deck can easily be locked into the transport position.*

## MAINTENANCE

### 7.1 MAINTENANCE CHART - RECOMMENDED SERVICE INTERVALS

Break-In (First 10)	HOURS					Procedure	Comments
	8	40	100	200	500		
X						Check all hardware for tightness	
X						Check hydraulic oil level	See paragraph 7.3
X						Check all belts for proper alignment	See paragraph 7.8
X (First 5)						Change engine oil and filter	See paragraph 7.4
X						Check hydraulic hoses for leaks	Use extreme caution when checking the hydraulic hoses See paragraph 2.5
X						Check Coolant Level (Kawasaki Only)	See paragraph 7.12
	X					Check engine oil level	See paragraph 7.4
	X					*Clean mower	See paragraph 7.14
	X					Check condition of blades	See paragraph 7.9
	X					Apply grease to fittings	See paragraph 7.2
	X					Check tire pressure	See paragraph 7.10
	X					Check Coolant Level (Kawasaki Only)	See paragraph 7.12
		X				Check battery electrolyte level, clean battery posts and cables	See paragraph 7.7
		X				Check belts for proper alignment	See paragraph 7.8
			X			Apply grease to fittings	See paragraph 7.2
			X			Change engine oil	See paragraph 7.4
			X			*Clean air cleaner element	See paragraph 7.6
			X			Check lubricant in cutter deck gearbox	See paragraph 7.11

\* Perform these maintenance procedures more frequently under extreme dusty or dirty conditions

### MAINTENANCE CHART - RECOMMENDED SERVICE INTERVALS (CONT'D)

Break-In (First 10)	HOURS					Procedure	Comments
	8	40	100	200	500		
				X		Apply grease to fittings	See paragraph 7.2
				X		Check hardware for tightness	
				X		Change engine oil filter	See paragraph 7.4
				X		Check hydraulic oil level	See paragraph 7.3
					X	Replace engine fuel filter	See paragraph 7.5
					X	Drain hydraulic system and replace hydraulic oil	See paragraph 7.3 Use SAE 20W50 Motor Oil
					X	Replace hydraulic oil filter	See paragraph 7.3
					X	Replace cutter deck gearbox lubricant	See paragraph 7.1
					X	Change Coolant (Kawasaki Only)	See paragraph 7.12

### 7.2 LUBRICATION

#### GREASE FITTING LUBRICATION CHART (SEE FIGURE 7-1)

LOCATION	LUBRICATION		NO. OF PLACES
	INTERVAL	LUBRICANT	
1 Caster Wheel Pivot	500 Hours/Yearly	Chassis Grease	2
2 Caster Wheel Bearings	100 Hours/Bi-Weekly	Chassis Grease	2
3 Brake Actuator	200 Hours/Monthly	Chassis Grease	2
4 Cutter Deck Bellcranks	100 Hours/Bi-Weekly	Chassis Grease	4
5 Cutter Deck Pusharms	100 Hours/Bi-Weekly	Chassis Grease	2
6 PTO Spindle	40 Hours/Weekly	+Lithium MP White Grease 2125	1
7 Cutter Deck Spindle	40 Hours/Weekly	+Lithium MP White Grease 2125	3
8 Brake Handle	200 Hours/Monthly	Chassis Grease	1
9 Cutter Deck Drive Shaft	100 Hours/Bi-Weekly	Chassis Grease	3

- + Compatible Greases: Mobilix #2 found at Mobil Service Stations  
 Ronex MP found at Exxon Service Stations  
 Super Lube MEP #2 & Super Stay-M #2 found at Conoco Stations  
 Shell Alvania #2 found at Shell Service Stations  
 Lidok EP #2 found at industrial shops

**GREASE FITTING LUBRICATION**

LUBRICANT / INTERVAL

- LITHIUM MP WHITE GREASE 2125  
( 40 HOURS / WEEKLY )
- CHASSIS GREASE  
( 100 HOURS / BI-MONTHLY )
- ⬡ CHASSIS GREASE  
( 200 HOURS / MONTHLY )
- △ CHASSIS GREASE  
( 500 HOURS / YEARLY )

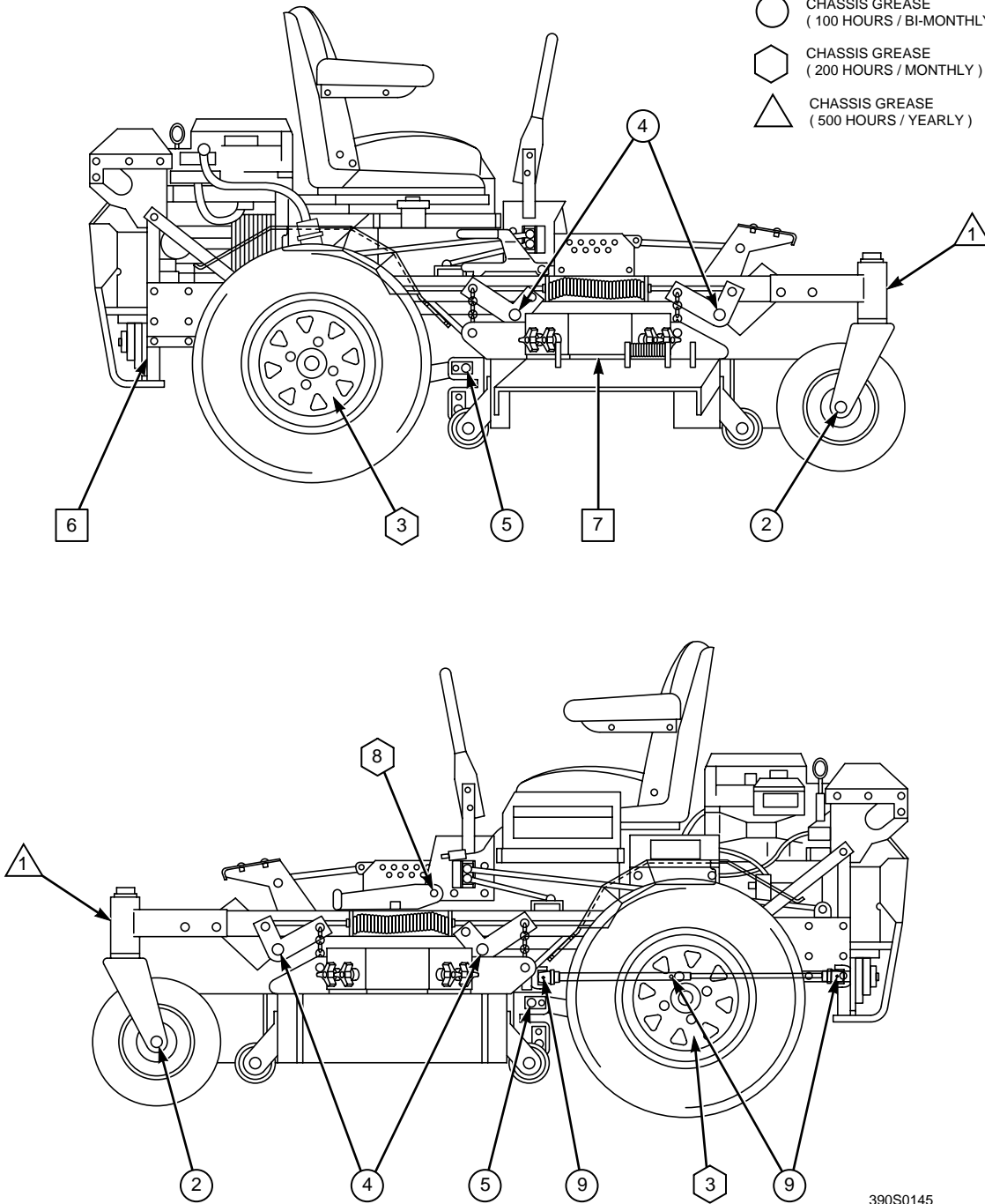

390S0145

**Figure 7.1 Lubrication Fitting Points**

### 7.3 HYDRAULIC SYSTEM

#### A. Checking Hydraulic Oil Level

The hydraulic oil level should be checked after the first 10 hours of operation. Thereafter, check the oil after every 200 hours of machine operation or monthly, whichever occurs first.

**- IMPORTANT -**

*If the oil level is consistently low, check for leaks and correct immediately.*

1. Wipe dirt and contaminants from around the reservoir cap. Remove the cap from the hydraulic oil reservoir.
2. Visually check the level of hydraulic oil. Hydraulic oil must be at least 3-1/4" inches from top of the filler neck. If the level cannot be determined visually, use a clean tape measure to check the level. If the fluid is low, add 20W50 motor oil. **DO NOT** overfill; (overfilling the oil reservoir may cause oil seepage).
3. Clean the fill cap and install it onto the reservoir.

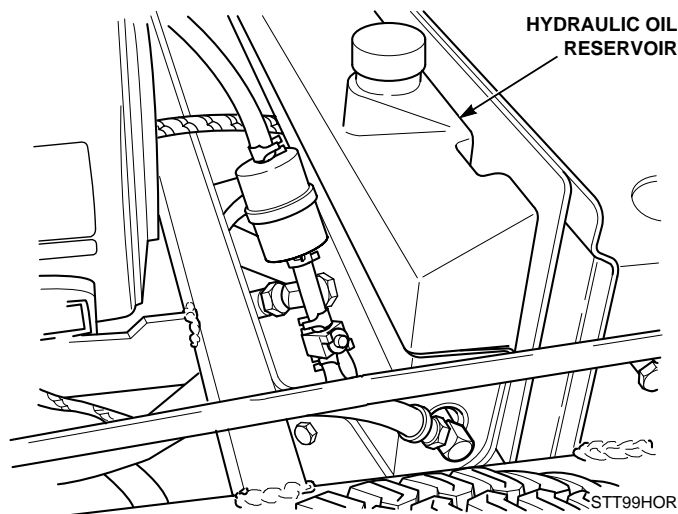

**Figure 7-2 Hydraulic Oil Reservoir**

#### B. Changing Hydraulic Oil

The hydraulic oil should be changed after every 500 hours or annually, whichever occurs first. The oil should also be changed if the color of the fluid has become black or milky. A black color and/or a rancid odor usually indicates possible overheating of the oil, and a milky color usually indicates water in the hydraulic oil.

**-NOTE-**

*The hydraulic oil should be changed if you notice the presence of water or a rancid odor to the hydraulic oil.*

1. Park the mower on a level surface and stop the engine.
2. Place a suitable container under the hydraulic oil reservoir. Remove the fill cap from the reservoir. Remove the drain plug from the bottom of the reservoir. (See Figure 7-2). Allow the fluid to drain into the container and properly discard it.
3. Re-install the drain plug into the reservoir and be sure it is tight.

**-NOTE-**

*Before refilling the hydraulic oil reservoir the hydraulic oil filter should be changed as outlined in section C on the next page.*

4. Fill the reservoir to 3-1/4" inches from the top of the filler neck with 20W50 motor oil.
5. Replace the reservoir fill cap. Start the engine and drive forward and backward for two minutes. Check the oil level in the reservoir. If necessary, add oil to the reservoir.

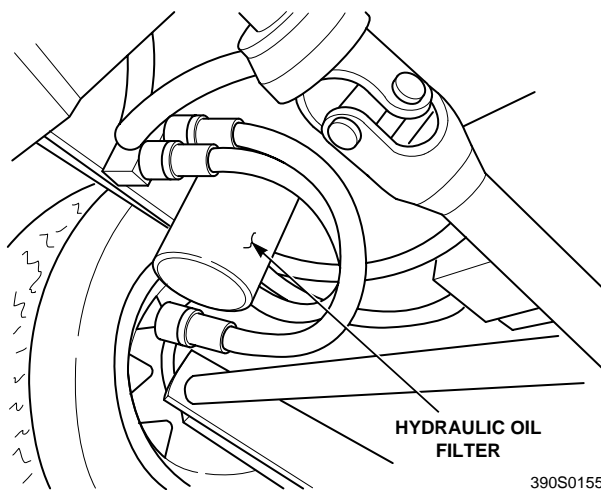

Figure 7-3 Hydraulic Oil Filter

### C. Changing Hydraulic Oil Filter Element

The hydraulic oil filter should be changed after every 500 hours of operation or annually, whichever occurs first.

1. Remove the oil filter element (Figure 7-3) and properly discard it. Fill the new filter with clean oil and install the filter. Hand tighten only.
2. Run the engine at idle speed with the speed control lever in neutral for five minutes.
3. Check the oil level in the hydraulic tank. It must be 3-1/4" inches from the top of the filler neck. If necessary, add SAE 20W50 motor oil.

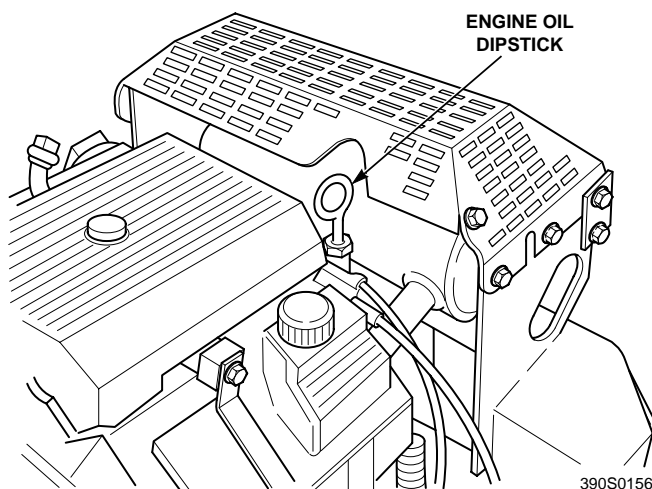

Figure 7-4 Engine Fill Stick

## 7.4 ENGINE OIL

### A. Checking Engine Crankcase Oil Level

The engine oil level should be checked after every 8 hours of operation or daily as instructed in the Engine Operator's Manual furnished with this mower.

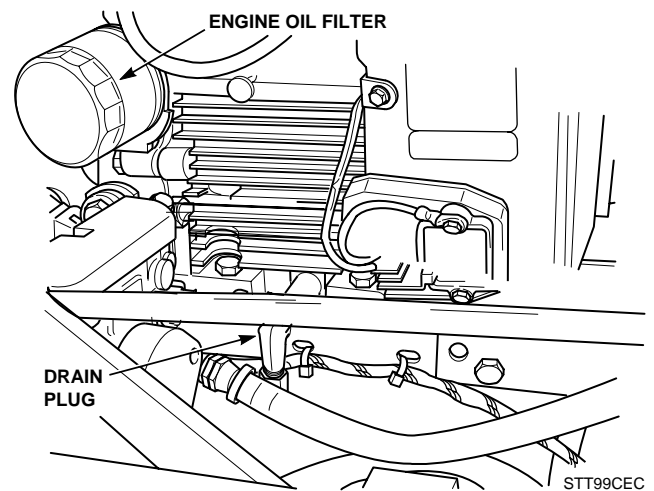

Figure 7-5 Drain Plug Location

### B. Changing Engine Crankcase Oil

After the first 5 hours of operation, change the engine crankcase oil and replace the oil filter. Thereafter, change the engine crankcase oil after every 100 hours of operation or bi-weekly, whichever occurs first. Refer to the Engine Operator's Manual furnished with this mower for instructions.

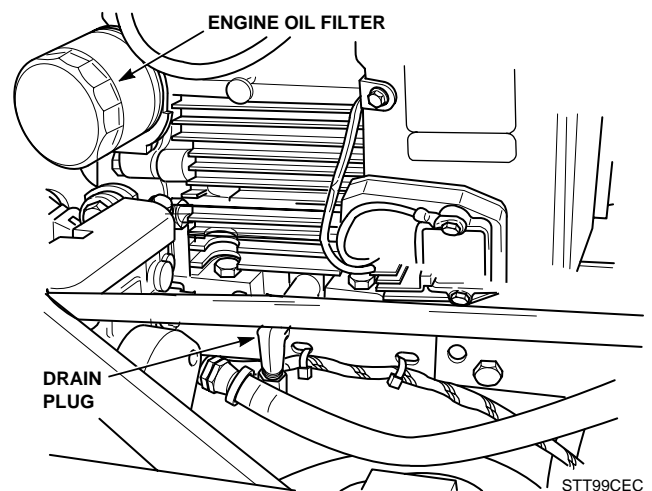

Figure 7-6 Engine Oil Filter Location

### C. Changing Engine Oil Filter

After the first 5 hours of operation, replace the engine oil filter. Thereafter, replace the oil filter after every 200 hours of operation or every month, whichever occurs first. Refer to Engine Operator's Manual for instructions.

### 7.5 ENGINE FUEL SYSTEM

#### **! DANGER:**

To avoid injury from burns, allow the mower to cool before removing the fuel tank cap and refueling.

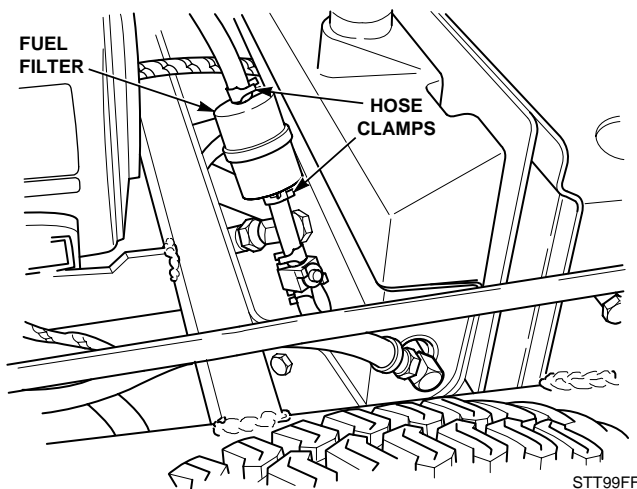

Figure 7-7 Fuel Filter

### A. Filling the Fuel Tank

Fill the fuel tank at the beginning of each operating day to within 1 inch below the filler neck. Do not overfill. Use clean, fresh unleaded gasoline with a minimum octane rating of 87.

### B. Replacing In-Line Fuel Filter Element

The in-line fuel filter (Figure 7-7) should be replaced after every 500 hours of operation or annually, whichever occurs first.

1. Close the shutoff valve. Remove the two clamps securing the fuel filter to the fuel hose. Remove the fuel filter.
2. Install a new fuel filter. Be sure it is installed in the proper direction. Secure to the fuel hose using the two clamps.

### 7.6 ENGINE AIR CLEANER

#### A. Cleaning and/or Replacing Air Cleaner Element

For any air cleaner, the operating environment dictates the air cleaner service periods. Inspect and clean the air cleaner element after every 100 hours of operation or bi-weekly, whichever occurs first and replace the element if required.

#### **-NOTE-**

*In extremely dusty conditions it may be necessary to check the element once or twice daily to prevent engine damage.*

1. Remove the wing nut securing the air cleaner cover to the engine. Remove the air cleaner cover and set aside.
2. Remove the air cleaner and inspect.
3. Clean or replace the air cleaner and foam pre-cleaner as recommended by the engine manufacturer.

## Section 7

### 7.7 BATTERY

#### A. Checking Electrolyte Level and Cleaning Battery

After every 40 hours of operation or weekly, whichever occurs first, check the electrolyte level in the battery and clean the battery and connections. Dirt and fluid on the top of the battery can cause the battery to discharge. Corrosion of the battery terminals or loose connections will cause poor battery performance.

#### **WARNING:**

Lead-acid batteries produce flammable and explosive gases. To avoid personal injury when checking, testing or charging batteries, **DO NOT** use smoking materials near batteries. Keep arcs, sparks and flames away from batteries. Provide proper ventilation and wear safety glasses.

1. Loosen the two plastic wing nuts and then remove the battery cover.
  2. Remove the battery cell caps. Visually inspect electrolyte level in the cells. If electrolyte is below the bottom of vent well, fill with clean distilled water to the bottom of vent wells (1/4 to 1/2 inch above the plates). Install the battery cell caps.
- IMPORTANT -**
- Do not overfill the battery. Electrolyte will overflow through the vent tube onto parts of the machine, resulting in severe corrosion.*
3. Clean the cable ends and battery posts with steel wool. Use a solution of baking soda and water to clean the battery. Do not allow the solution to enter the battery cells.
  4. Tighten the cable connections securely and apply a light coat of silicone dielectric grease to the terminal connections to prevent corrosion.
  5. Install the battery cover.

#### **WARNING:**

Electric storage battery fluid contains sulfuric acid which is **POISON** and can cause **SEVERE CHEMICAL BURNS**. Avoid contact of fluid with eyes, skin, or clothing. Use proper protective gear when handling batteries. **DO NOT** tip any battery beyond 45° angle in any direction. If fluid contact does occur, follow first aid suggestions below.

#### BATTERY ELECTROLYTE FIRST AID

**EXTERNAL CONTACT** — Flush with water.

**EYES** — Flush with water for at least 15 minutes and get medical attention immediately.

**INTERNAL** — Drink large quantities of water. Follow with Milk Of Magnesia, beaten egg, or vegetable oil. Get medical attention immediately. In case of internal contact, **DO NOT** give fluids that would induce vomiting.

#### B. Charging the Battery

Refer to the battery charger's manual for specific instructions.

Under normal conditions the engine's alternator will have no problem keeping a charge on the battery. If the battery has been completely discharged for a long period of time, the alternator may not be able to recharge the battery, and a battery charger will be required.

**DO NOT** charge a frozen battery. It may explode and cause injury. Let the battery warm before attaching a charger.

Whenever possible, remove the battery from the mower before charging and make sure the electrolyte covers the plates in all cells.



### **WARNING:**

**BATTERIES PRODUCE EXPLOSIVE GASES. Charge the battery in a well ventilated space so gases produced while charging can dissipate.**

Charging rates between 3 and 50 amperes are satisfactory if excessive gassing or spewing of electrolyte does not occur or the battery does not feel excessively hot (over 125°F). If spewing or gassing occurs or the temperature exceeds 125°F, the charging rate must be reduced or temporarily stopped to permit cooling.

### C. Jump Starting

1. The booster battery must be a 12 volt type. If a vehicle is used for jump starting, it must have a negative ground system.
2. When connecting the jumper cables, connect the positive cable to the positive battery post, then connect the negative cable to the negative battery post.

## 7.8 DRIVE BELTS

All drive belts are spring loaded and self-tensioning, however after the first 2, 4, 8 and 10 hours of operation, the belts should be checked for proper alignment and wear. Thereafter, check the belts after every 40 hours of operation or weekly, whichever occurs first.

**-NOTE-**

*If you experience frequent belt wear or breakage, see your authorized Scag service center for belt adjustment.*

## 7.9 CUTTER BLADES

### A. Blade Inspection

1. Remove the ignition key before servicing the blades.
2. Raise the mower deck to the highest position. Place the lanyard pin in the highest cutting height position to prevent the cutter deck from falling.

### **WARNING:**

**Always wear proper hand and eye protection when working with cutter blades.**

3. Check the cutter blades for straightness. If the cutter blades appear bent, they will need to be replaced.

### **WARNING:**

**Do not attempt to straighten a bent blade, and never weld a broken or cracked blade. Always replace it with a new blade to assure safety.**

4. If a blade cutting edge is dull or nicked, it should be sharpened. Remove the blades for sharpening. See "Blade Replacement."

**-NOTE-**

*Keep the blades sharp. Cutting with dull blades not only yields a poor mowing job, but slows the cutting speed of the mower and causes extra wear on the engine and the blade drive by pulling hard.*

### B. Blade Sharpening

**-NOTE-**

*If possible, use a file to sharpen the blade. Using a wheel grinder may burn the blade.*

**-NOTE-**

*DO NOT sharpen the blades beyond 1/3 of the width of the blade.*

1. Sharpen the cutting edge at the same bevel as the original. See Figure 7-9. Sharpen only the top of the cutting edge to maintain sharpness.

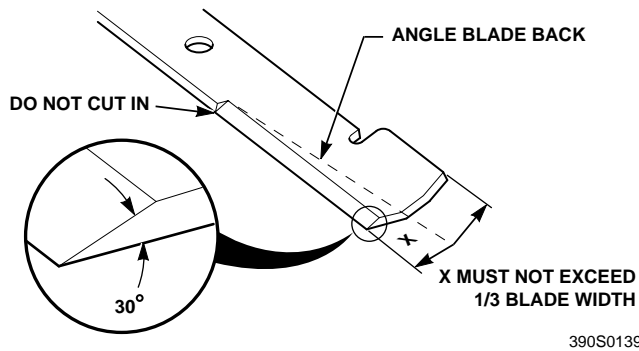

**Figure 7-9 Blade Sharpening**

2. Check the balance of the blade. If the blades are out of balance, vibration and premature wear can occur. See your authorized Scag dealer for blade balancing or special tools, if you choose to balance your own blades.

### C. Blade Replacement

#### **WARNING:**

Always wear proper hand and eye protection when working with cutter blades.

1. Remove the ignition key before replacing the blades.
2. Raise the mower deck to the highest position. Place the lanyard pin in the highest cutting height position to prevent the cutter deck from falling.
3. Secure the cutter blades to prevent them from rotating. (Use the optional Blade Buddy tool, P/N 9212, to assist in securing the cutter blades), remove the nut from the blade attaching bolt. Remove the cutter blade, bolt and spacer from the spindle shaft. (Figure 7-10).

**-NOTE-**

*The front of the machine will have to be raised slightly to remove the blade bolt from the cutter spindle.*

4. To install the new cutter blade, put the flat washer onto the blade bolt and slide the bolt into the hole in the cutter blade.

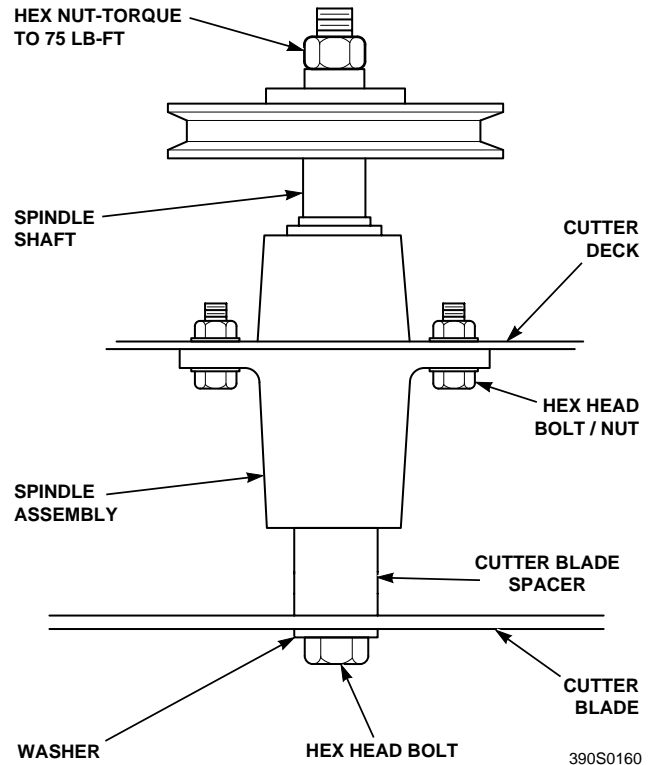

**Figure 7-10 Blade Replacement**

**-NOTE-**

*Be sure that the blade is installed with the lift wing toward the top.*

5. Install the spacer onto the blade bolt and insert the bolt into the cutter spindle shaft.
6. Install the hex nut to the blade bolt at the top of the cutter spindle. Secure the blades from rotating and torque to 75 ft-lbs. (See Figure 7-10)

### 7.10 TIRES

Check the tire pressures after every 8 hours of operation or daily.

Caster Wheels .....	25 PSI
Drive Wheels .....	12 PSI

### 7.11 CUTTER DECK GEARBOX

#### A. Checking Lubricant Level

#### **CAUTION:**

The cutter deck gearbox can reach high operating temperatures. Allow the cutter deck gearbox to cool before servicing.

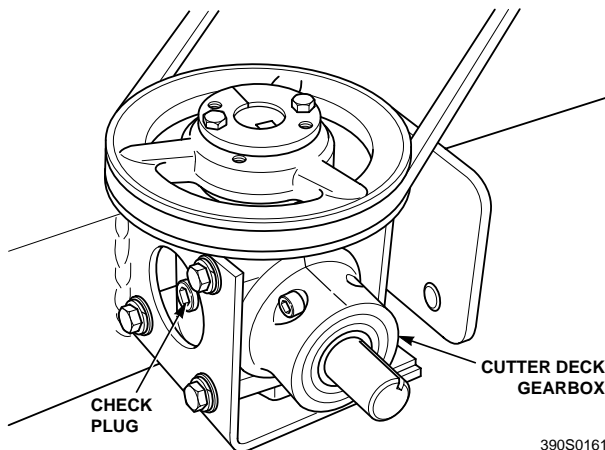

**Figure 7-12 Cutter Deck Gearbox**

The fluid level in the cutter deck gearbox (Figure 7-12) should be checked after every 100 hours of operation or bi-weekly, whichever occurs first.

1. Lower the cutter deck to its lowest position to gain access to the cutter deck gearbox.
2. Clean and remove the check plug from the side of the gearbox (See Figure 7-12). Visually check that the lubricant level is up to the bottom edge of the check plug hole. If lubricant is low, add SAE 80W90 lubricant through the check plug hole in the gearbox until it is level with the bottom of the check plug hole. Install the check plug and tighten securely.

#### B. Changing Lubricant

The lubricant in the cutter deck gearbox should be changed after every 500 hours of operation or yearly, whichever occurs first.

1. Place a suitable container beneath the cutter deck gearbox and locate the gearbox drain plug.

2. Remove the drain plug and drain the lubricant into the container and properly discard it.
3. Re-install the drain plug and add EP-80/90 lubricant through the check plug hole in the gearbox until it is level with the bottom of the check plug hole. Install the check plug and tighten securely.

### 7.12 KAWASAKI COOLING SYSTEM

#### **WARNING:**

To avoid burns, always allow the engine to cool before removing the radiator cap.

#### A. Checking Coolant Level

The coolant level should be checked before each day of operation.

1. Remove the radiator cap by turning it slowly counterclockwise to the first stop and allow any pressure to be released. Push down on the cap and turn counterclockwise to remove.
2. Visually check the coolant level. The coolant level should be up to the bottom of the filler neck as shown in figure 7-13. Add a mixture of coolant and soft water as needed.

**-NOTE-**

Refer to the coolant manufacture's instructions for the proper coolant mixture ratio.

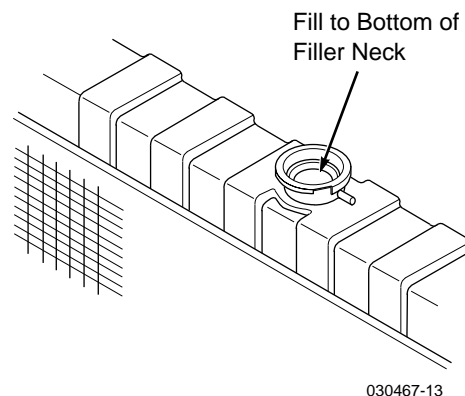

**Figure 7-13 Cutter Deck Gearbox**

## Section 7

3. Replace the radiator cap. Push down on the cap and turn clockwise until it stops.

**-NOTE-**

*The cooling system should be flushed and the coolant replaced every 500 hours of operation or annually. See your Scag dealer for proper coolant replacement.*

### B. Cleaning the Radiator Debris Screen

After each day of operation, remove and clean the radiator debris screen.



**CAUTION:**

**To avoid personal injury, always wear safety glasses when using compressed air.**

1. Pull the debris screen up to remove.
2. Clean the debris screen with compressed air or a water hose.

**-NOTE-**

*Check the radiator for excessive debris and clean with compressed air. Never spray a hot engine with water, use only compressed air to remove debris.*

3. Re-install the debris screen to the radiator.

### C. Checking The Fan Belt Tension

Periodically check the fan belt tension. The belt should deflect 1/2" with 10 pounds of pressure. See your Scag dealer if the belt is in need of adjustment or replacement.

## 7.13 BODY, DECK, AND UPHOLSTERY



**CAUTION:**

**Do not wash any portion of the equipment while it is hot. Do not wash the engine; use compressed air.**

1. After each use, wash the mower and cutter deck. Use cold water and automotive cleaners. Do not use pressure cleaners.
2. Do not spray electrical components.
3. Use a mild soap solution or a vinyl/rubber cleaner to clean the seat.
4. Repair damaged metal surfaces using Scag touch-up paint available from your authorized Scag dealer. Wax the mower for maximum paint protection.



### 52" & 61" CUTTER DECKS

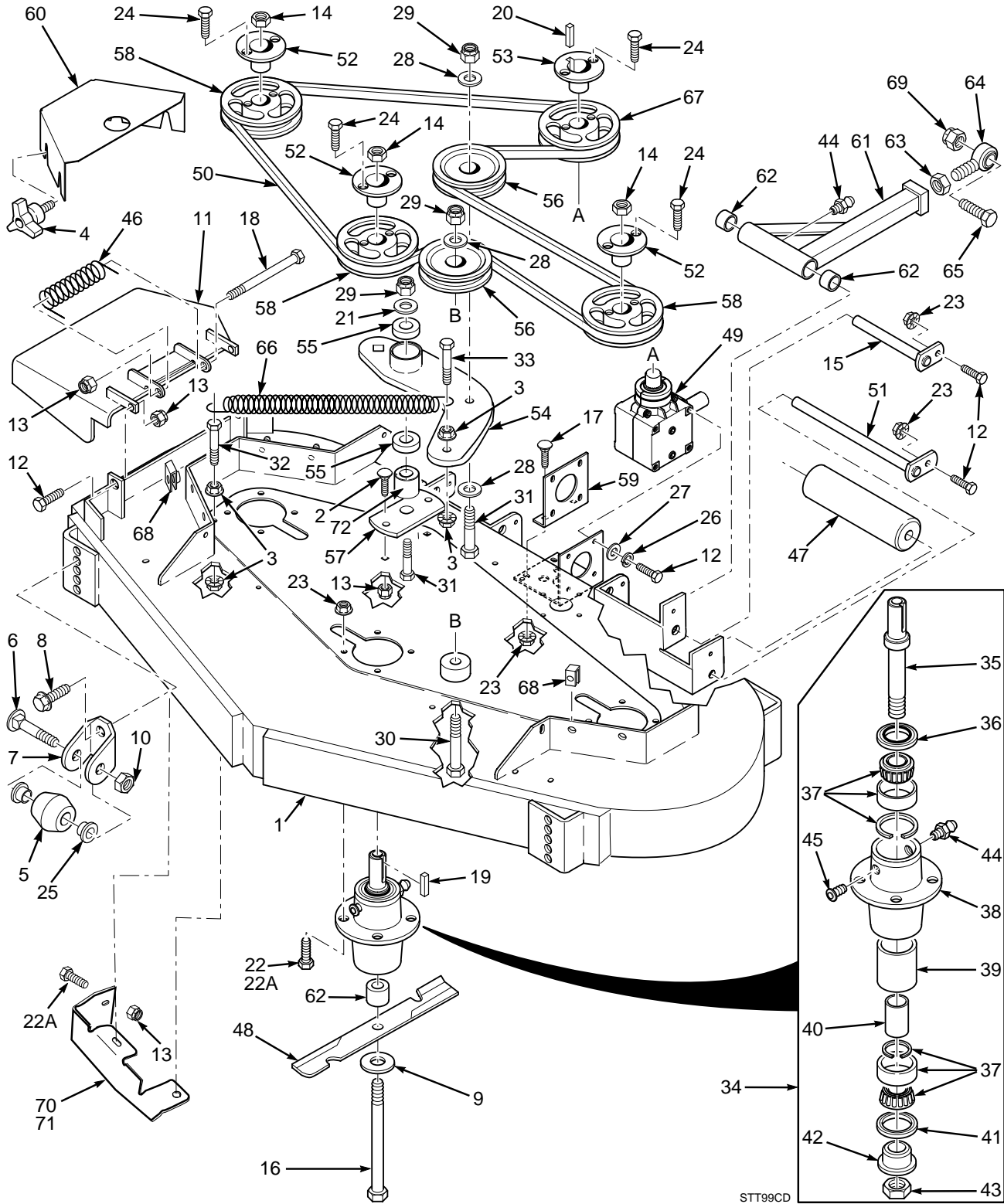

STT99CD

# Section 8



## 52" & 61" CUTTER DECKS

Ref. Part No. No.	Description	52	61	Ref. Part No. No.	Description	52	61
1	461137	Cutter Deck (Includes decals)	x	35	43298	Spindle Shaft	x x
	461141	Cutter Deck (Includes decals)		36	481024	Seal, Top	x x
	461145	Cutter Deck Bahia (Not Shown)	x				
	461147	Cutter Deck Bahia (Not Shown)		37	481022	Bearing Assembly	x x
2	04003-04	Bolt, Carriage 5/16-18 x 1"	x	38	43294	Spindle Housing	x x
3	04019-04	Nut, Hex Serrated Flange 3/8-16	x	39	43312	Spacer, Outside	x x
4	481625-01	Wing nut, 3/8-16	x	40	43296	Spacer, Inside	x x
5	481632	Anti-Scalp Wheel	x	41	481025	Seal, Bottom	x x
6	04003-26	Bolt, Carriage 3/8-16 x 4"	x	42	43297	Spindle Bushing, Bottom	x x
7	422478	Anti-Scalp Wheel Bracket	x	43	481035	Nut, Special 1 - 1/16-18	x x
8	04017-27	Bolt, Hex Serrated Flange 3/8-16 x 1"	x	44	48114-04	Grease Fitting	x x
9	04040-10	Flatwasher, 5/8" (.688 x 1.75 x .134)	x	45	48677	Relief Fitting, Tapered Spindle	x x
10	04021-05	Locknut, 3/8-16 Center Lock	x	46	481050	Spring, Discharge Chute	x x
11	461054	Discharge Chute	x	47	48038	Guide, Roller	x x
	461055	Discharge Chute		48	48108	Cutter Blade, 18"	x
	461058	Discharge Chute Bahia (Not Shown)	x		48111	Cutter Blade, 21"	x
	461059	Discharge Chute Bahia (Not Shown)	x	49	481516	Gearbox Assembly, Deck Drive	x x
12	04001-09	Bolt, Hex Head 5/16-18 x 1"	x	50	481557	Belt, Cutter Deck Drive	x
13	04021-10	Nut, Hex Elastic Stop 5/16-18	x		481558	Belt, Cutter Deck Drive	x
14	04020-09	Nut, 5/8-11 UNC	x	51	45944	Roller Shaft	x x
15	45332	Push Arm Shaft	x	52	48926	Tapered Hub, 1-1/8" Bore	x x
16	04001-41	Bolt, Hex Head 5/8-11 x 9-1/2"	x	53	48141	Tapered Hub, 1" Bore	x x
17	04003-12	Bolt, Carriage 5/16-18 x 3/4"	x	54	461075	Idler Arm, Cutter Deck	x x
18	04001-108	Bolt, Hex Head 5/16-18 x 4-1/2"	x	55	48224	Bearings, Ball	x x
19	04063-08	Key, 1/4 x 1/4 x 2"	x	56	48269	Pulley, Idler	x x
20	04063-01	Key, 1/4 x 1/4 x 1-1/4"	x	57	422713	Pivot Weldment, Idler	x x
21	04043-04	Flatwasher, 3/8-.39 x .938 x .105 HD	x	58	48753	Pulley, 6.35 O.D.	x x
22	04001-10	Bolt, Hex Head 5/16-18 x 1-1/4"	x	59	422426	Mounting Plate, Gearbox	x x
22A	04001-11	Bolt, Hex Head 5/16-18 x 1-1/2"	x	60	422412	Belt, Cover	x
23	04019-03	Nut, Hex Serrated Flange 5/16-18	x		422413	Belt, Cover	x
24	04001-01	Bolt, Hex Head 1/2-20 x 3/4"	x	61	461036	Pusharm (includes items 44, 62, 63 & 64)	x x
25	48100-15	Bushing, .376 I.D. Oilite	x	62	43309	Spacer, Spindle	x x
26	04030-03	Lockwasher, 5/16"	x	63	04020-16	Nut, Hex Head 5/8-18 UNF	x x
27	04040-15	Flatwasher, 5/16" (.375 x .875 x .083)	x	64	48763	Rod End, 5/8" Male RH Thread	x x
28	04041-07	Flatwasher, 3/8" (.391 x .938 x .105)	x	65	04001-79	Bolt, Hex Head 5/8-11 x 4-1/2"	x x
29	04021-09	Nut, Hex Elastic Stop 3/8-16	x	66	481597	Spring, Cutter Deck	x x
30	04001-62	Bolt, Hex Head 3/8-16 x 3-1/4"	x	67	48967	Pulley, 6.95 O.D.	x
31	04001-31	Bolt, Hex Head 3/8-16 x 2-1/2"	x		48753	Pulley, 6.35 O.D.	x
32	04001-20	Bolt, Hex Head 3/8-16 x 1-1/2"	x	68	04110-03	U-Nut, 3/8-16	x x
33	04001-136	Bolt, Hex Head 3/8-16 x 1-1/2" Grade 8	x	69	04021-13	Nut, Hex Elastic Stop 5/8-11	x x
34	46631	Spindle Assembly	x	70	422600	Discharge Baffle 52"	x
				71	422601	Discharge Baffle 61"	
				72	43503	Pivot, Idler - Short	x

\* Common hardware which should be purchased locally. All bolts Grade 5 plated, all other fasteners zinc plated.

### CUTTER DECK CONTROLS, 52" & 61" DECKS

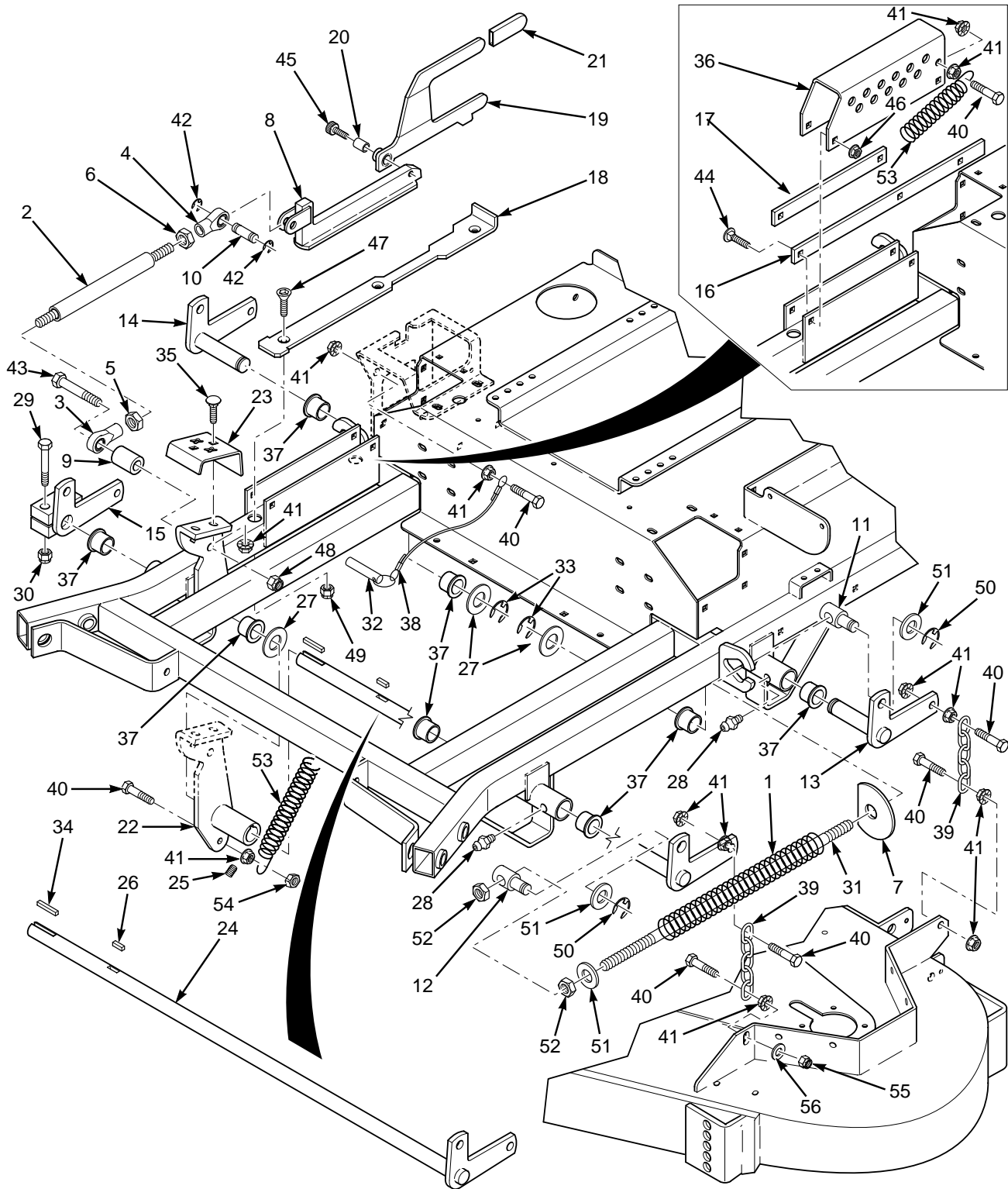

CUTTER DECK

STT99CDC



## CUTTER DECK CONTROLS, 52" & 61" DECKS

Ref. No.	Part No.	Description
1	481549	Spring, Deck Lift
2	481763	Link, Deck Lift
3	481765	Rod End, Female - 1/2-20 RH
4	481766	Rod End, Female - 1/2-20 LH
5	04020-27	Nut, Jam 1/2-20 RH
6	04020-28	Nut, Jam 1/2-20 LH
7	422439	Flatwasher, Spring Stop
8	481560	Slide Weldment, Height Adjustment
9	43391	Spacer, Decklift Pedal
10	43487	Pin, Decklift
11	43472	Swivel Joint, LH
12	43473	Swivel Joint, RH
13	45904	Bellcrank Weldment, LH Rear
14	45905	Bellcrank Weldment, RH Rear
15	45907	Bellcrank Weldment, RH Front
16	422381	Guide, Short
17	422380	Guide, Long
18	422346	Lockplate, Decklift
19	46975	Deck Latch (Includes items 20 & 21)
20	48100-14	Bushing, .502 ID.
21	481428	Grip, Deck Latch
22	45945	Footplate Weldment, Decklift
23	422451	Footplate, Height Adjustment
24	45906	Bellcrank Weldment, LH Front
25	04012-09	Set Screw, 5/16-18 x 1/2" Sq. Head
26	04063-23	Key, 1/4 x 1/4 x 3-1/4"
27	04041-14	Flatwasher, 1" (1.062 x 1.50 x .048)
28	48114-04	Grease Fitting
29	04001-91	Bolt, Hex Head 7/16-14 x 2-1/2"
30	04021-11	Nut, Hex Elastic Stop 7/16-14
31	04004-33	Stud, 5/8-11 x 22.0"
32	04067-05	Ring Pin, 1/2 x 3.30"
33	04050-08	Ring, Retaining 1" External "E"
34	04063-01	Key, 1/4 x 1/4 x 1-1/4"
35	04003-11	Bolt, Carriage 3/8-16 x 1-1/4"
36	422403	Bracket, Cutting Height Adjustment
37	48100-08	Bushing, 1.003 ID.
38	481547	Lanyard, Deck Height Pin
39	48540	Chain
40	04001-20	Bolt, Hex Head 3/8-16 x 1-1/2"
41	04019-04	Nut, Hex Serrated Flange 3/8-16
42	04050-10	Ring, Retaining 1/2" External "E"
43	04001-74	Bolt, Hex Head 1/2-13 x 3"
44	04003-04	Bolt, Carriage 5/16-18 x 1"
45	04009-02	Bolt, Shoulder 1/2 x 3/4"
46	04019-03	Nut, Hex Serrated Flange 5/16-18
47	04014-03	Screw, Cap 5/16-18 x 3" FHHS
48	04021-07	Nut, Hex Elastic Stop 1/2-13
49	04021-10	Nut, Hex Elastic Stop 5/16-18
50	04050-01	Ring, Retaining 5/8" External "E"
51	04040-09	Flatwasher, 5/8" (.656 x 1.312 x .095)
52	04020-09	Nut, Hex 5/8-11
53	481522	Spring, Helper (61" Cutter Deck Only)
54	04021-05	Locknut, 3/8-16 Center Lock
55	04021-09	Nut, 3/8-16 Elastic Stop
56	04041-07	Flatwasher, 3/8"

\* Common hardware which should be purchased locally. All bolts Grade 5 plated, all other fasteners zinc plated.

### SHEET METAL COMPONENTS

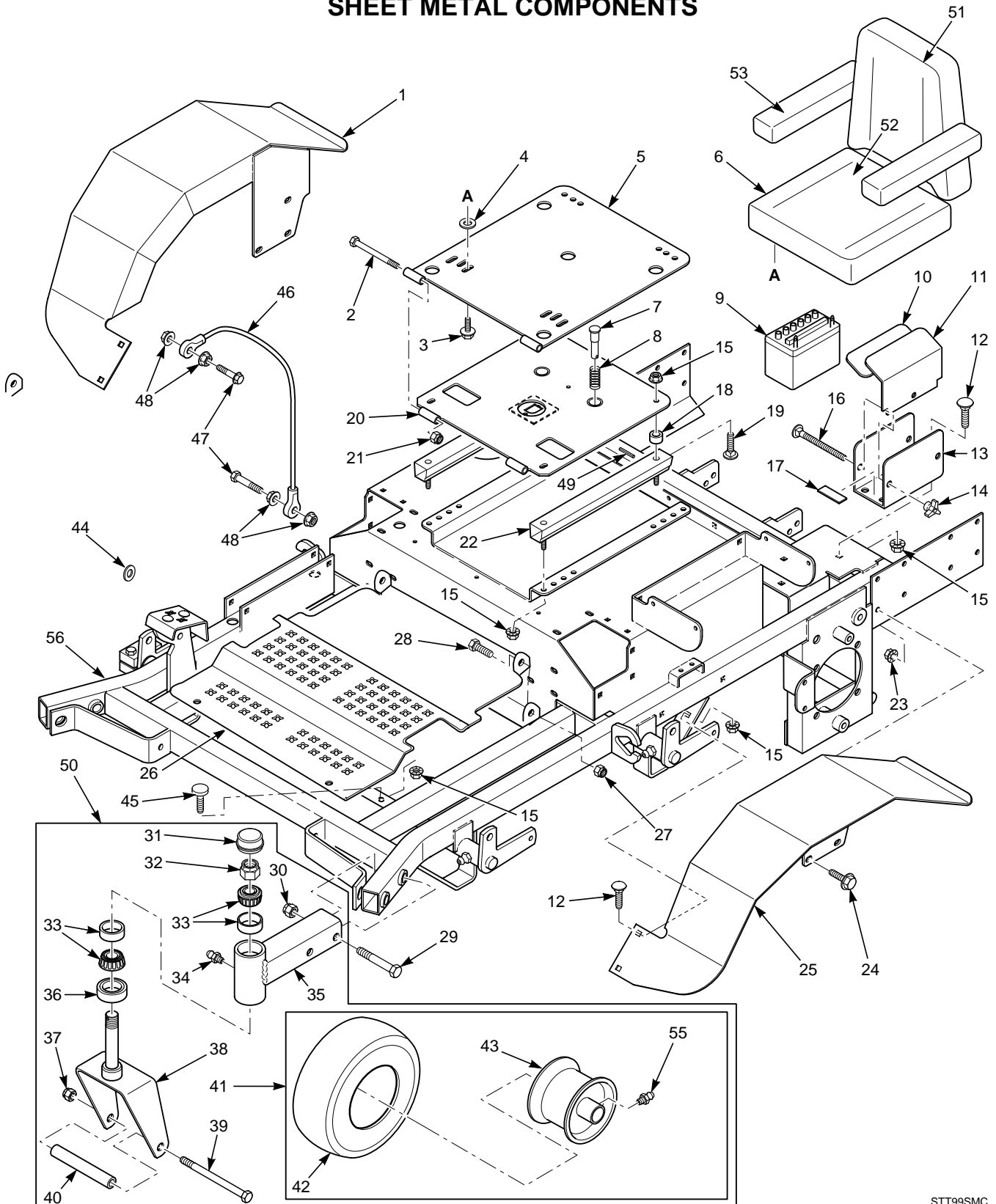

STT99SMC

## SHEET METAL COMPONENTS

Ref. No.	Part No.	Description
1	451079	Fender Weldment, RH
2	04001-63	Bolt, Hex Head 5/16-18 x 3-1/2"
3	04017-16	Screw, Hex Serrated Flange 5/16-18 x 3/4"
4	04041-11	Flatwasher, 3/8" (.406 x 1.50 x .179)
5	45926	Seat Plate Weldment, Upper
6	481532	Seat
7	43462	Pin Retainer, Spring
8	481389	Spring, Seat
9	48015	Battery
10	48903	Pad, Battery Cover
11	421274	Cover, Battery
12	04003-12	Bolt, Carriage 5/16-18 x 3/4"
13	421703	Plate, Battery Box
14	04029-01	Wing Nut, 1/4-20 x 3/4"
15	04019-03	Nut, Hex Serrated Flange 5/16-18
16	04003-01	Bolt, Carriage 1/4-20 x 6"
17	48657	Rubber Pad
18	43336	Spacer
19	04003-04	Bolt, Carriage 5/16-18 x 1"
20	45925	Seat Plate Weldment, Lower
21	04021-10	Nut, Hex Elastic Stop 5/16-18
22	481943	Seat Adjustment, Track Set
23	04019-04	Nut, Hex Serrated Flange 3/8-16
24	04017-27	Screw, Hex Serrated Flange 3/8-16 x 1"
25	451078	Fender Weldment, LH
26	422567	Foot Plate
27	04021-09	Nut, Hex Elastic Stop 3/8-16
28	04001-19	Bolt, Hex Head 3/8-16 x 1-1/4"
29	04001-125	Bolt, Hex Head 5/8-11 x 4"
30	04021-13	Nut, Hex Elastic Stop 5/8-11
31	481559	Cap, Grease
32	04021-20	Nut, Hex Elastic Stop 1.0-14
33	48668	Bearing W/Race
34	48114-04	Grease Fitting
35	45935	Extension Weldment, Caster 52" Deck (LH & RH)
	45936	Extension Weldment, Caster 52"B & 61" (LH)
	45937	Extension Weldment, Caster 52"B (RH) & 61"B (LH & RH)
	45989	Extension Weldment, Caster 61"(RH)
36	481025	Seal, 2.00 OD. x 1.625 Bore
37	04021-07	Nut, Hex Elastic Stop 1/2-13
38	45934	Yoke Weldment, Caster
39	04001-134	Bolt, Hex Head 1/2-13 x 7-1/2"
40	43430	Sleeve
41	481551	Wheel Assembly (Includes items 34 & 42 thru 47)
42	481613	Tire
43	481612	Rim Assembly (Includes item 55)
44	04041-07	Washer, 3/8"
45	481284	Bumper, Rubber
46	48566	Cable, Seat Stop
47	04001-59	Bolt, Hex Head 1/4-20 x 1-1/4"
48	04019-02	Nut, Hex Serrated Flange 1/4-20
49	04060-01	Roll Pin, Spring 5/32 x 3/4"
50	46986	Caster Wheel Assembly (Includes items 31 thru 47) - 52"B (RH) & 61"B (LH & RH)
	46984	Caster Wheel Assembly (Includes items 31 thru 47) - 52" Deck (LH & RH)
	46985	Caster Wheel Assembly (Includes items 31 thru 47) - 52"B & 61" (LH)
	461040	Caster Wheel Assembly (Includes items 31 thru 47) - 61"(RH)
51	481532-01	Back Cushion
52	481532-02	Cushion Assembly
53	481532-03	Arm Pad, RH
	481532-04	Arm Pad, LH
54	48831-01	Bracket, Armrest-LH
	48831-02	Bracket, Armrest-RH
55	48114-06	Grease Fitting,

### DECK DRIVE COMPONENTS

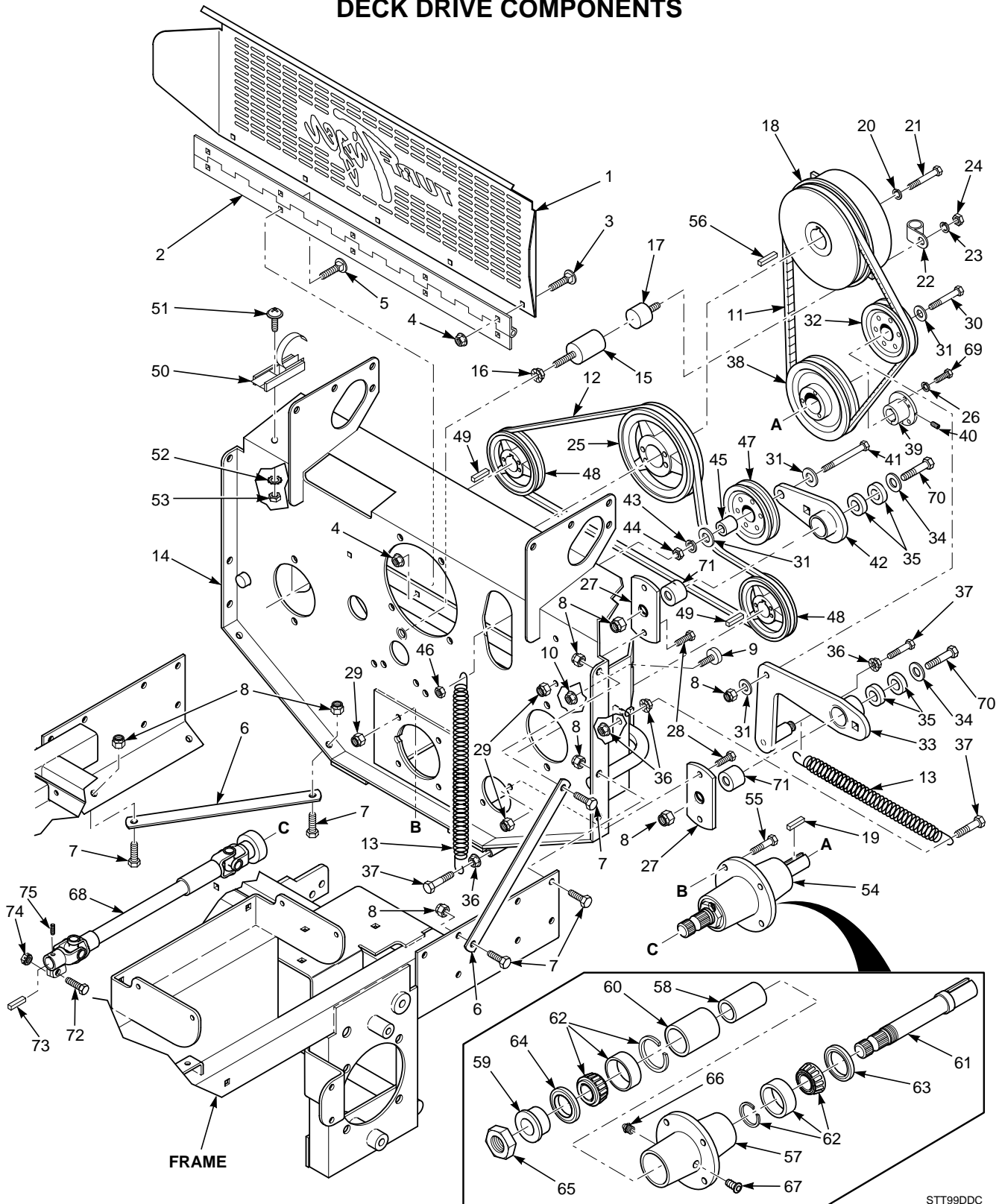

STT99DDC

## DECK DRIVE COMPONENTS

Ref. Part No. No.	Description	Ref. Part No. No.	Description
1	422594 Belt Guard	51	04010-01 Screw, Phillips Washer Head #10-32 x 1/2"
2	481531 Hinge, Belt Guard	52	04031-01 Lockwasher, #10-32 External Tooth
3	04003-07 Bolt, Carriage 1/4-20 x 1/2"	53	04020-01 Nut, Hex #10-32
4	04019-02 Nut, Hex Serrated Flange 1/4-20	54	46977 Spindle Assembly (Includes items 57 thru 67)
5	04003-02 Bolt, Carriage 1/4-20 x 3/4"	55	04001-10 Bolt, Hex Head 5/16-18 x 1-1/4"
6	422386 Brace, Engine Mounting	56	04063-20 Key, 1/4 x 1/4 x 1"
7	04001-19 Bolt, Hex Head 3/8-16 x 1"	57	43294 Spindle Housing
8	04021-09 Nut, Hex Elastic Stop 3/8-16	58	43296 Spacer, Inside
9	481284 Bumper, Rubber	59	43297 Spindle Bushing, Bottom
10	04019-03 Nut, Hex Serrated Flange 5/16-18	60	43312 Spacer, Outside
11	481460 Belt, Deck Drive	61	43321 Shaft, PTO Deck Drive
12	481461 Belt, Pump Drive	62	481022 Roller Bearing Assembly
13	481522 Spring, Main Drive	63	481024 Seal, 2.00 OD. x 1.50 Bore
14	451021 Pump Mounting Weldment	64	481025 Seal, 2.00 OD. x 1.625 Bore
15	43428 Base, Clutch Anti-Rotation	65	481035 Nut, 1.06-18
16	04019-05 Nut, Hex Serrated Flange 7/16-14	66	48114-04 Grease Fitting 1/4-28 Self Tap
17	481469 Isolator, Rubber	67	48677 Relief Fitting
18	481530 Electric Clutch	68	481528 Drive Shaft
19	04063-06 Key, 1/4 x 1/4 x 1-1/2"	69	04001-109 Bolt, Hex Head 1/4-20 x 1-3/8" Full Thread
20	04030-05 Lockwasher, 7/16"	70	04001-31 Bolt, Hex Head 3/8-16 x 2.50
21	04001-101 Bolt, Hex Head 7/16-20 x 2-1/2"	71	43503 Pivot, Idler - Short
22	48030-09 Clamp, Cable 1/2" ID.	72	04001-21 Bolt, Hex Head 3/8-16 x 1-3/4"
23	04030-03 Lockwasher, 5/16"	73	04063-20 Key,
24	04020-03 Nut, Hex 5/16-18	74	04021-05 Nut, Center Lock 3/8-16
25	481535 Pulley, 6.00 OD. 1.125 Bore	75	04012-08 Screw, Set 3/8-16 x 3/8
26	04030-02 Lockwasher, 1/4"		
27	422714 Base, Idler Arm		
28	04001-09 Bolt, Hex Head 5/16-18 x 1"		
29	04021-10 Nut, Hex Elastic Stop 5/16-18		
30	04001-46 Bolt, Hex Head 3/8-16 x 2-1/4"		
31	04041-07 Flatwasher, 3/8" (.391 x .938 x .105)		
32	48181 Pulley, Idler		
33	461079 Idler Arm W/Bearings (Includes Item 35)		
34	04043-04 Flatwasher, 3/8 GR 8 Special		
35	48224 Ball Bearings		
36	04019-04 Nut, Hex Serrated Flange 3/8-16		
37	04001-136 Bolt, Hex Head 3/8-16 x 1-1/2"		
38	481398 Pulley, 6.35 Dia. Taper Bore		
39	481536 Tapered Hub, 1.00 Bore		
40	04012-05 Setscrew, Hex Socket 1/4-20 x 1/2"		
41	04001-138 Bolt, Hex Head 3/8-16 x 3-3/4"		
42	461091 Idler Arm Assembly (Includes item 35)		
43	04030-04 Lockwasher, 3/8"		
44	04020-04 Nut, Hex 3/8-16		
45	43277 Spacer		
46	04021-05 Locknut, Hex Center Lock 3/8-16		
47	48198 Pulley, Idler 5.00 Dia.		
48	48586 Pulley		
49	04063-14 Key, 5 x 5 x 25 mm		
50	481309 Latch, Hood		

\* Common hardware which should be purchased locally. All bolts Grade 5 plated, all other fasteners zinc plated.

### ENGINE AND ATTACHING PARTS - KOHLER

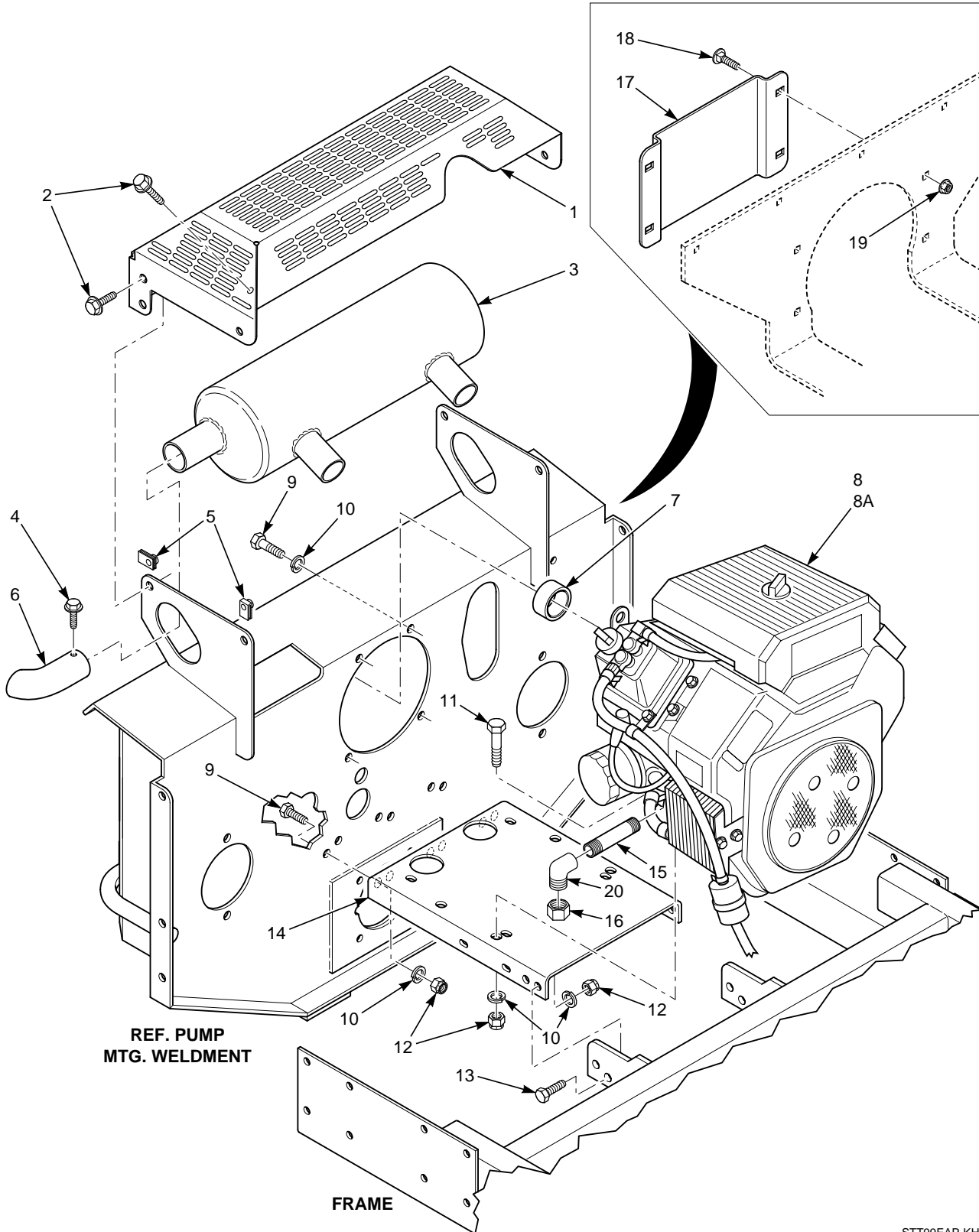

STT99EAP-KH

## ENGINE AND ATTACHING PARTS - KOHLER

Ref. No.	Part No.	Description
1	422593	Muffler Guard
2	04017-05	Screw, Hex Serrated Flange 1/4-20 x 3/4"
3	*	Muffler, Part Of Engine (Available only through Kohler)
4	04011-09	Screw, #10-16 x 1/2"
5	04110-01	U-Nut, 1/4-20
6	481584	Exhaust Elbow
7	43421	Spacer, Engine (Kohler)
8	481758	Engine, Kohler 22CH (Available only through Kohler, Eng. Spec. PS 76510)
	481759	Engine, Kohler 25 CH (Available only through Kohler, Eng. Spec. PS 68613)
9	04001-19	Bolt, Hex Head 3/8-16 x 1"
10	04030-04	Lockwasher, 3/8" Spring
11	04001-21	Bolt, Hex Head 3/8-16 x 1-3/4"
12	04021-09	Nut, Hex Elastic Stop 3/8-16
13	04001-32	Bolt, Hex Head 3/8-16 x 1-1/4"
14	422396	Plate, Engine Mounting
15	48402-01	Extension, Oil Drain 2"
16	48257	Pipe Cap, Hex 3/8"
17	422475	Rear Cover
18	04003-12	Bolt, Carriage 5/16-18 x 3/4"
19	04019-03	Nut, Hex Serrated Flange 5/16-18
20	48600-01	Street Elbow, 3/8" NPT

\* Common hardware which should be purchased locally. All bolts Grade 5 plated, all other fasteners zinc plated.

### ENGINE AND ATTACHING PARTS - KAWASAKI

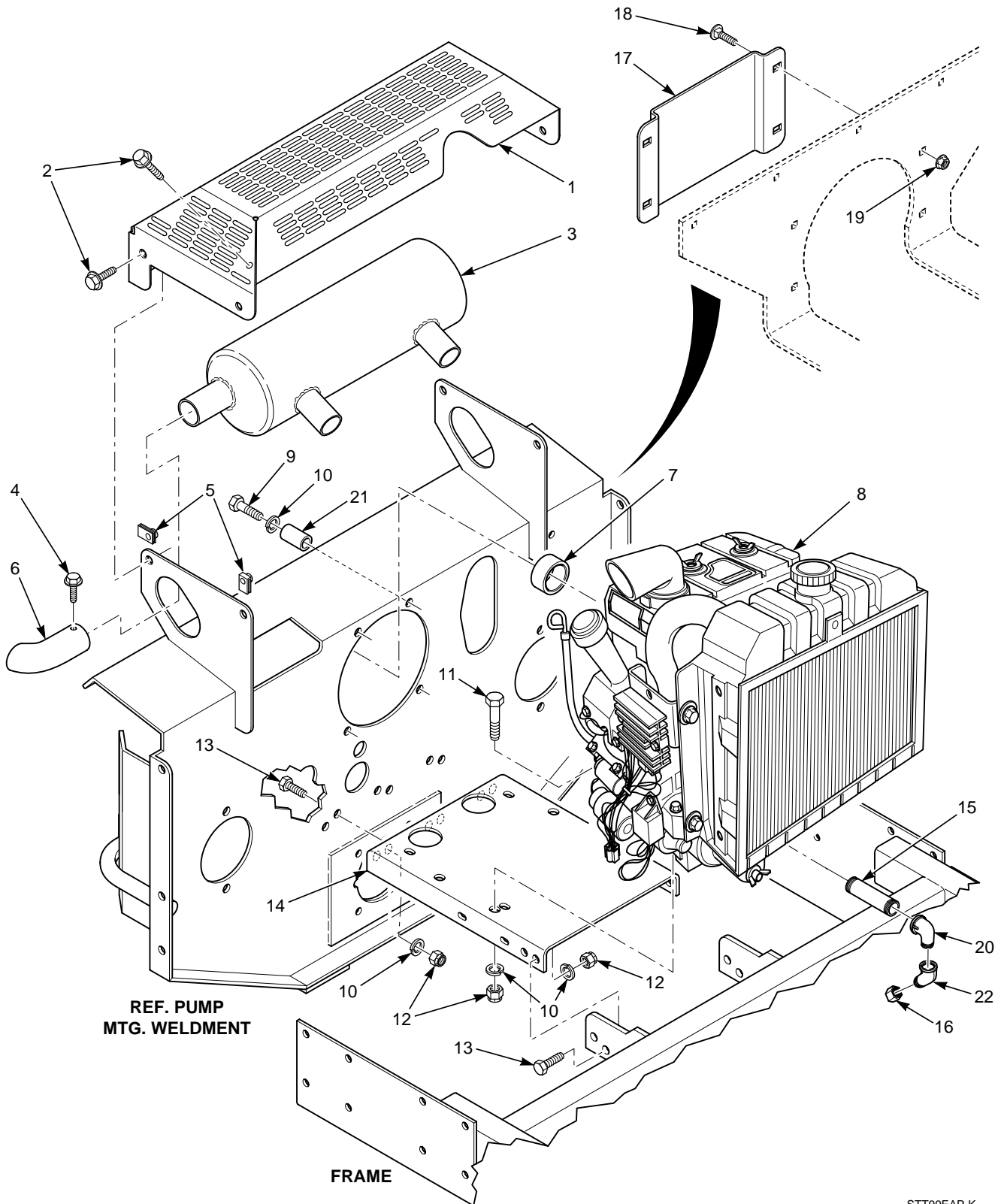



## ENGINE AND ATTACHING PARTS - KAWASAKI

Ref. No.	Part No.	Description
1	422593	Muffler Guard
2	04017-05	Screw, Hex Serrated Flange 1/4-20 x 3/4"
3	*	Muffler, Part Of Engine (Available only through Kawasaki)
4	04011-09	Screw, #10-16 x 1/2"
5	04110-01	U-Nut, 1/4-20
6	481584	Exhaust Elbow (Kawasaki)
7	43420	Spacer, Engine (Kawasaki)
8	481574	Engine, Kawasaki 22KA (Available only through Kawasaki)
9	04002-03	Bolt, M8-1.25 x 25 Grage 8.8
10	04030-04	Lockwasher, 3/8" Spring
11	04001-21	Bolt, Hex Head 3/8-16 x 1-3/4"
12	04021-09	Nut, Hex Elastic Stop 3/8-16
13	04001-32	Bolt, Hex Head 3/8-16 x 1-1/4"
14	422396	Plate, Engine Mounting
15	48402-05	Extension, Oil Drain 4"
16	48257	Pipe Cap, Hex 3/8"
17	422475	Rear Cover
18	04003-12	Bolt, Carriage 5/16-18 x 3/4"
19	04019-03	Nut, Hex Serrated Flange 5/16-18
20	48600-01	Street Elbow, 3/8" NPT
21	43498	Spacer, Engine Bolt
22	481730-01	Street Elbow, 45 Deg.-3/8" NPT

\* Common hardware which should be purchased locally. All bolts Grade 5 plated, all other fasteners zinc plated.

### BRAKE AND STEERING COMPONENTS

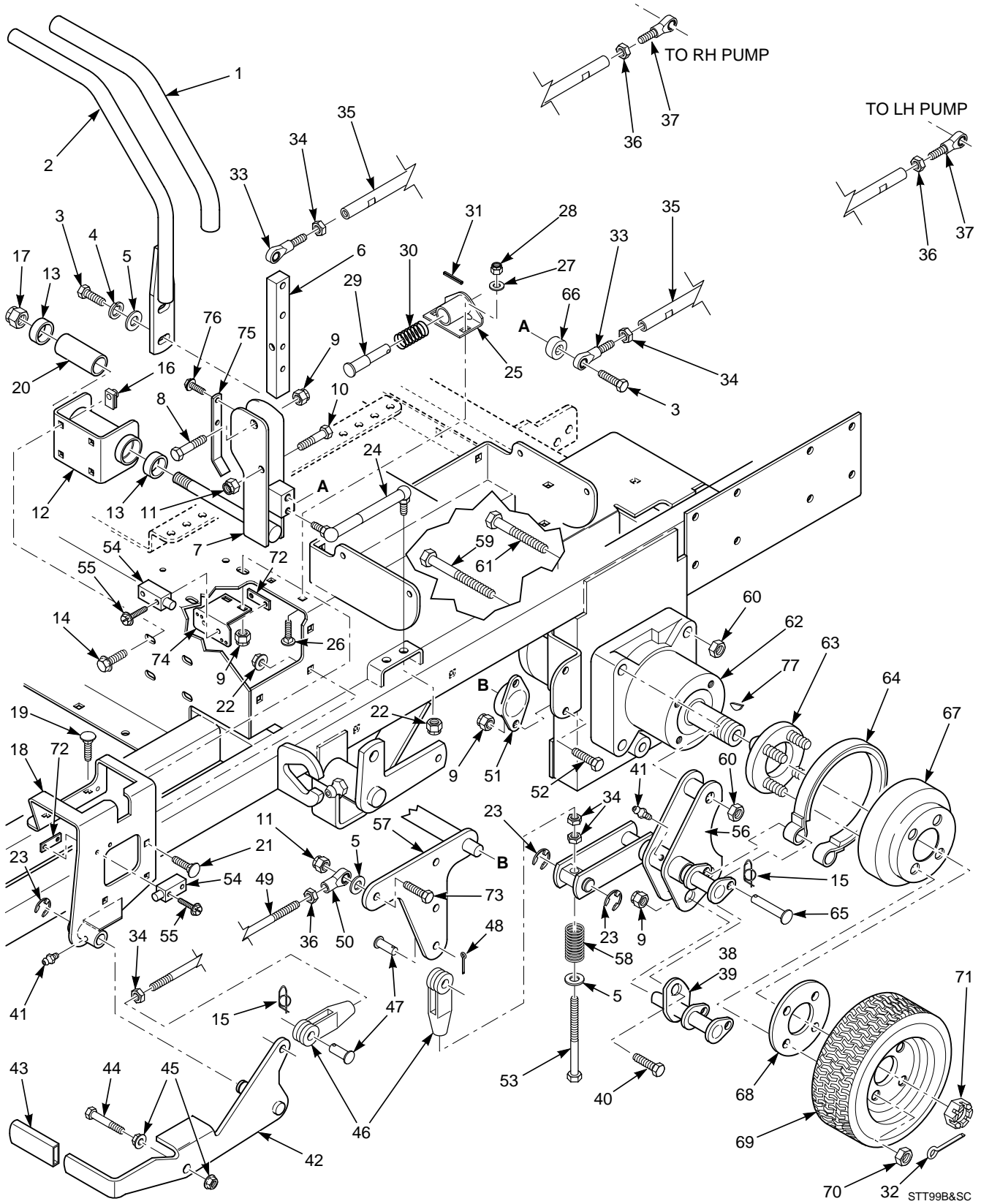

## BRAKE AND STEERING COMPONENTS

Ref. Part No. No.	Description	Ref. Part No. No.	Description		
1	481599	Grip, Handle Bar	51	48796	Bushing, Self Align
2	461037	Handle Bar (Includes item 1)	52	04001-08	Bolt, Hex Head 5/16-18 x 3/4"
3	04001-32	Bolt, Hex Head 3/8-16 x 1-1/4"	53	04001-147	Bolt, Hex Head 3/8-24 x 5-1/4", 2-3/4" Thread
4	04030-04	Lockwasher, 3/8"	54	481637	Switch
5	04041-07	Flatwasher, 3/8" (.391 x .938 x .105)	55	04010-12	Screw, Hex SLTD WSHR Head #10-32 x 3/4"
6	422372	Bar, Control Lever	56	45978	Brake Linkage, LH
7	45915	Control Lever		45979	Brake Linkage, RH
8	04001-17	Bolt, Hex Head 5/16-18 x 2"	57	45953	Bellcrank, Brake Actuator
9	04021-10	Nut, Hex Elastic Stop 5/16-18	58	48807	Spring
10	04001-45	Bolt, Hex Head 3/8-16 x 2"	59	04001-145	Bolt, Hex Head 1/2-13 x 3-1/2"
11	04021-09	Nut, Hex Elastic Stop	60	04021-19	Locknut, Hex 1/2-13 Center Lock
12	461080	Bracket, Control (Includes items 13 & 20)	61	04001-52	Bolt, Hex Head 1/2-13 x 2-1/2"
13	48224	Ball Bearings, Neutral Return	62	481529	Wheel Motor, Ross
14	04001-10	Bolt, Hex Head 5/16-18 x 1-1/4"	63	46929	Wheel Hub Assembly
15	04069-01	Pin, Rue Cotter 3/8 DIA	64	481601	Brake Band Assembly
16	04110-02	U-Nut, 5/16-18	65	04064-03	Pin, Clevis 3/8" Dia. x 2"
17	04021-13	Nut, Hex Elastic Stop 5/8-11	66	43063	Spacer
18	45973	Bracket, Control Lever LH	67	48513	Brake Drum
	422362	Bracket, Control Lever RH	68	422487	Spacer, Wheel
19	04003-04	Bolt, Carriage 5/16-18 x 1"	69	481850	Wheel Assembly 24 x 12-12 Turf Master
20	43465	Spacer, Bearing		481851	Rim W/Valve Stem
21	04003-12	Bolt, Carriage 5/16-18 x 3/4"		481852	Tire, 24 x 12-12 Turf Master
22	04019-03	Nut, Hex Serrated Flange 5/16-18	70	04028-01	Lug Nut, 1/2-20
23	04050-01	Ring, Retaining 5/8" External "E"	71	48680	Nut, Hex Castle
24	461090	Gas Damper (Includes Ball Stud & Spring Clip)	72	422373	Plate, Threaded
	481356	Ball Stud, Gas Spring (Not Shown)	73	04001-20	Bolt, Hex Head 3/8-16 x 1-1/2"
	481357	Spring Clip, Gas Spring (Not Shown)	74	422494	Bracket, Switch Mounting
25	45918	Bracket, Neutral Return	75	422493	Bracket, Switch Actuator
26	04003-02	Bolt, Carriage 1/4-20 x 3/4"	76	04017-16	Bolt, Hex Serrated Flange 5/16-18 x 3/4"
27	04040-14	Flatwasher, 1/4" (.312 x .750 x .065)	77	04063-25	Key, Woodruff 5/16 x 1"
28	04021-08	Nut, Hex Elastic Stop 1/4-20			
29	43477	Pin, Retaining Spring			
30	481389	Spring			
31	04060-01	Roll Pin, Spring 5/32 x 3/4"			
32	04061-06	Pin, Cotter 9/16 x 1-1/2"			
33	481539	Rod End, Male 3/8-24 RH THD.			
34	04020-25	Nut, 3/8-24 RH THD.			
35	43463	Tube, Control Link			
36	04020-26	Nut, Hex 3/8-24 LH THD.			
37	481538	Rod End, Male 3/8-24 LH THD.			
38	451073	Brake Linkage Weldment LH			
39	451074	Brake Linkage Weldment RH			
40	04001-09	Bolt, Hex Head 5/16-18 x 1"			
41	48114-04	Grease Fitting			
42	461082	Lever, Parking Brake (Includes item43)			
43	481548	Grip, Parking Brake			
44	04001-22	Bolt, Hex Head 3/8-16 x 2-3/4"			
45	04019-04	Nut, Hex Serrated Flange 3/8-16			
46	48343-02	Clevis, Traction Control			
47	04064-02	Pin, Clevis 3/8-16 x 1-1/16"			
48	04061-02	Pin, Cotter 3/32 x .75			
49	04004-34	Rod, Parking Brake			
50	48544	Rod End, LH THD.			

\* Common hardware which should be purchased locally. All bolts Grade 5 plated, all other fasteners zinc plated.

### FUEL AND HYDRAULIC SYSTEM

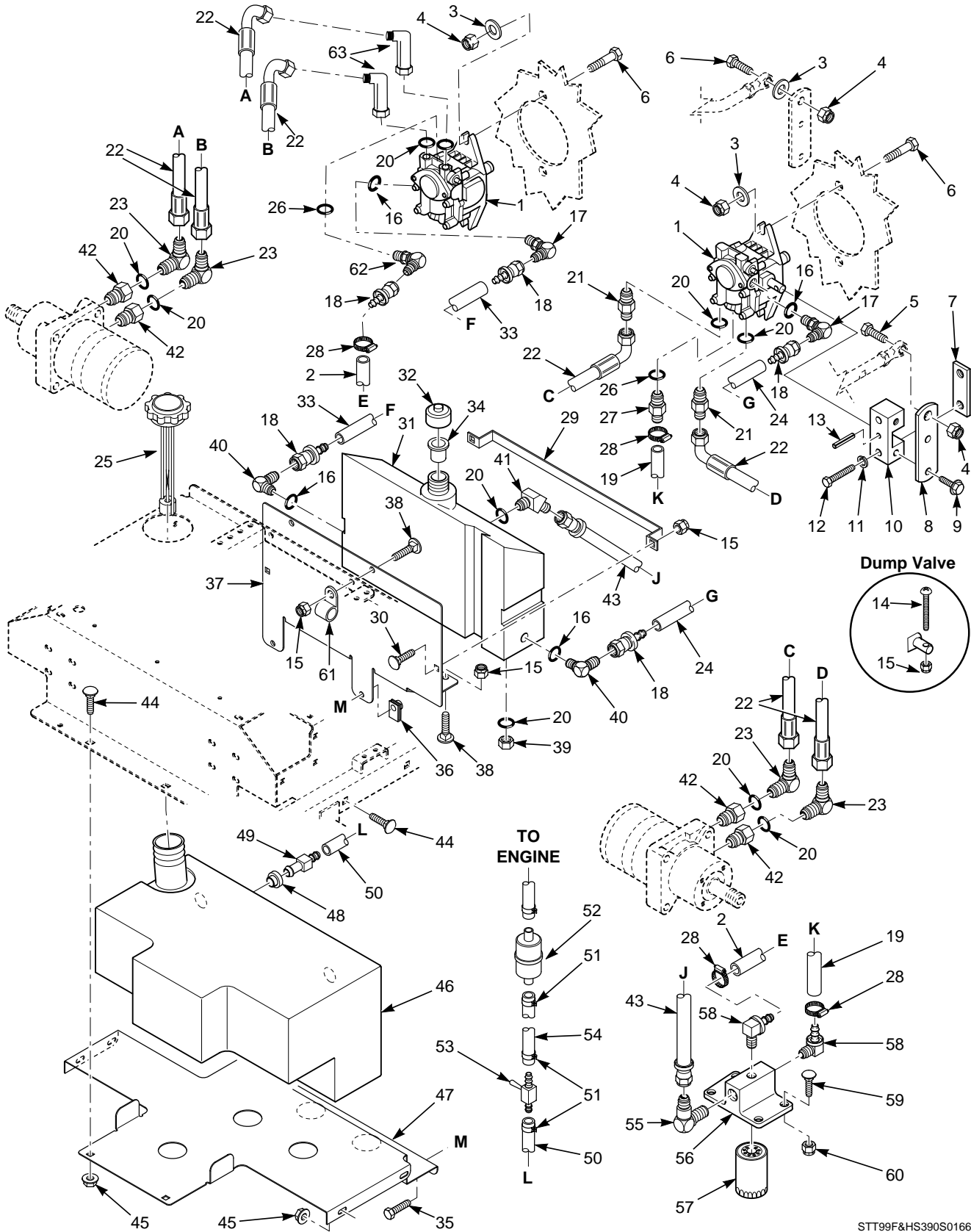

STT99F&HS390S0166

## FUEL AND HYDRAULIC SYSTEM

Ref. Part No. No.	Description	Ref. Part No. No.	Description		
1	48551	Pump, Sunstrand BDP-10L117	54	48058	Fuel Hose, 1/4" ID.-2" (order by the inch)
2	48811	Hose, 3/8" ID. Pushlock-38.0" (order by the inch)	55	48573-02	Elbow, 45 Degree-1/2 NPT x 3/4 JIC
3	04043-04	Flatwasher, 3/8" (.391 x .938 x .105) Grade 8	56	48471-02	Oil Filter Base
4	04021-09	Nut, Hex Elastic Stop 3/8-16	57	48758	Oil Filter
5	04001-32	Bolt, Hex Head 3/8-16 x 1-1/4"	58	481301-03	Elbow, 90 Degree-1/4 NPT x 3/8 Hose
6	04001-20	Bolt, Hex Head 3/8-16 x 1-1/2"	59	04003-04	Bolt, Carriage 5/16-18 x 1"
7	421203	Clamp Plate, Pump Control	60	04021-10	Nut, Hex Elastic Stop 5/16-18
8	422379	Lever, Control	61	48030-09	Hose Clamp
9	04017-05	Screw, Hex Serrated Flange 1/4-20 x 3/4"	62	48350-10	Elbow, 90 degree - 9/16x7/16 o-ring
10	48829	Block, Pump Control	63	481761-01	Elbow, 90 degree LG - 3/4-16 o-ring
11	04030-02	Lockwasher, 1/4" Spring			
12	04001-59	Bolt, Hex Head 1/4-20 x 1-1/4"			
13	04060-06	Roll Pin, Spring 3/16 x 3/4"			
14	04010-10	Screw, Phillips RD. Head 1/4-20 x 2"			
15	04021-08	Nut, Hex Elastic Stop 1/4-20			
16	48603-06	O-Ring			
17	48350-09	Elbow, 90 Degree			
18	48353-06	Coupling			
19	48811	Hose, 3/8" ID Push Lock			
20	48603-02	O-Ring			
21	48572-04	Union, 3/4-16 JIC x 3/4-16 O-Ring			
22	481611	Hose Assembly, Pump			
23	48350-02	Elbow, 90 Degree 3/4-16 JIC x 3/4-16 O-Ring			
24	48811	Hose, 3/8" ID. Pushlock-19.0" (order by the inch)			
25	481661	Cap, Fuel Tank W/Gauge			
26	48603-03	O-Ring			
27	481467-01	Connector, 7/16" O-Ring x Hose Barb			
28	48136-07	Clamp, Hose 1/2"			
29	421208	Strap, Hydraulic Tank			
30	04003-06	Bolt, Carriage 1/4-20 x 1"			
31	46978	Oil Reservoir Assembly			
32	481164	Cap, Hydraulic Tank			
33	48811	Hose, 3/8" ID. Pushlock-16.0" (order by the inch)			
34	481507	Insert, Filler Neck			
35	04001-01	Bolt, Hex Head 1/4-20 x 3/4"			
36	04110-01	U-Nut, 1/4-20			
37	422354	Support Bracket, Hydraulic Tank			
38	04003-02	Bolt, Carriage 1/4-20 x 3/4"			
39	48604-02	Plug, 3/4-16 "O" Ring			
40	48350-09	Elbow, 90 Degree 9/16-18 JIC x 9/16 O-Ring			
41	48573-02	Elbow, 45 Degree 3/4-16 JIC x 3/4-16 O-Ring			
42	48938-02	Bushing, 7/8-14 JIC x 3/4-16 O-Ring			
43	48872	Hose Assembly, 1/2" ID			
44	04003-12	Bolt, Carriage 5/16-18 x 3/4"			
45	04019-03	Nut, Hex Serrated Flange 5/16-18			
46	46974	Fuel Tank Assembly (Includes items 48 & 49)			
47	422353	Support Bracket, Fuel Tank			
48	48309	Bushing			
49	481602	Hose Fitting			
50	48058	Fuel Hose, 1/4" ID.-10" (order by the inch)			
51	48059-01	Clamp, Fuel Hose			
52	**	Fuel Filter			
53	48568	Valve, Shutoff			

\* Common hardware which should be purchased locally. All bolts Grade 5 plated, all other fasteners zinc plated.

\*\* Available through the individual engine manufacturer.

### ELECTRICAL SYSTEM (KOHLER)

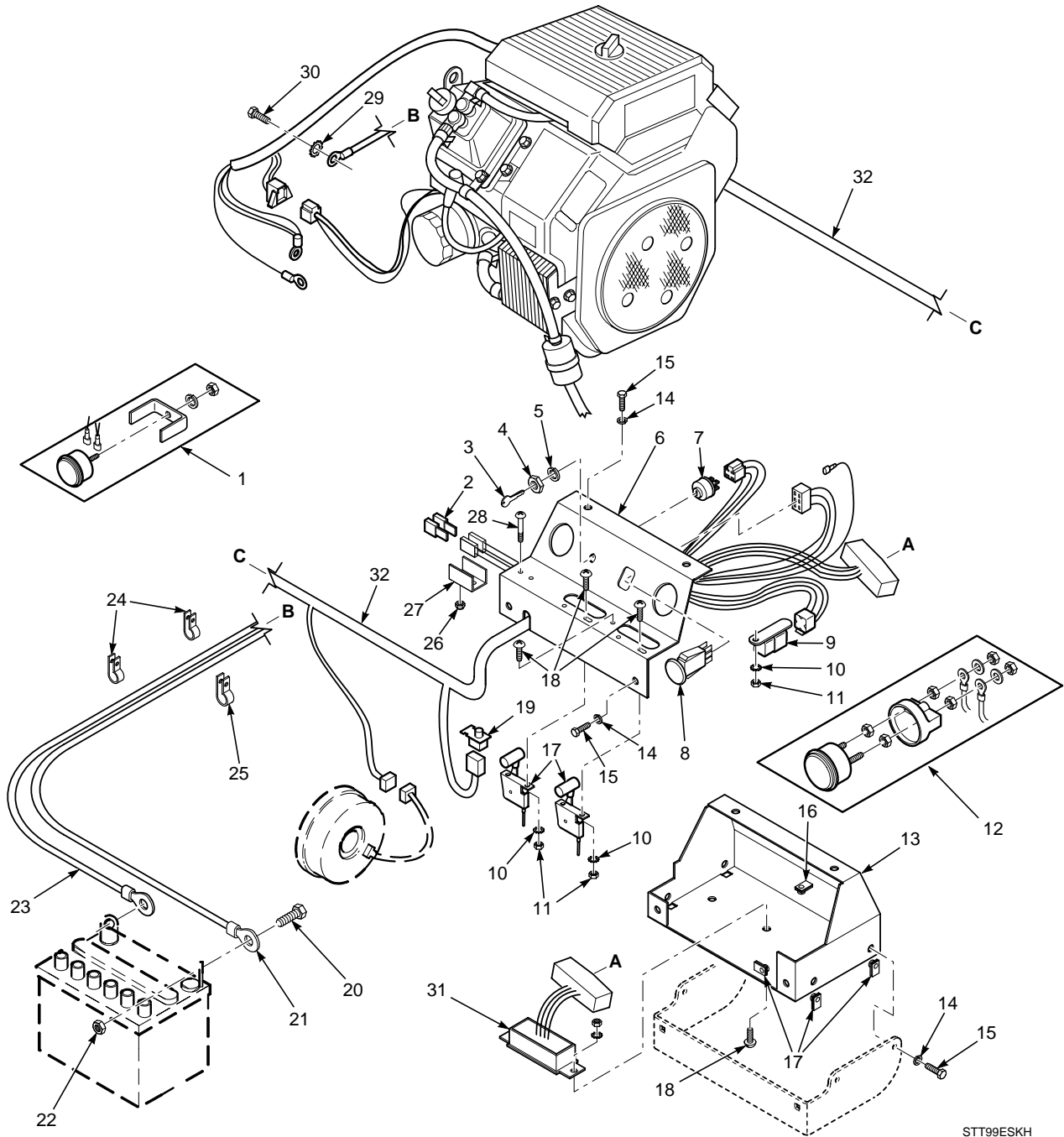

STT99ESKH

## ELECTRICAL SYSTEM (KOHLER)

Ref. No.	Part No.	Description
1	48023	Hour Meter
2	48298	Fuse, 20 AMP
3	48017-02	Key & Ring Assembly
4	48017-04	Nut, Hex 5/8-32
5	48017-03	Lockwasher, 5/8" Internal
6	422495	Instrument Panel, Top
7	48798	Key Switch
8	481687	Switch, PTO
9	48788	Relay
10	04031-01	Lockwasher, #10 External Tooth
11	04020-01	Nut, Hex #10-32
12	481755	Ammeter
13	451081	Base, Instrument Panel
14	04030-02	Lockwasher, 1/4"
15	04001-01	Bolt, Hex Head 1/4-20 x 3/4"
16	04110-01	U-Nut, 1/4-20
17	481544	Throttle And Choke Controls
18	04010-01	Screw, Phillips Washer Head #10-32 x 1/2"
19	481638	Switch, Interlock-Seat
20	04001-44	Bolt, Hex Head 1/4-20 x 1/2"
21	48029-18	Cable, Battery - Red 20"
22	04020-02	Nut, Hex 1/4-20
23	48029-07	Cable, Battery - Black
24	48030-09	Clamp, Cable 1/2" ID.
25	48030-10	Clamp, Cable 3/4" ID.
26	04021-01	Nut, Hex Elastic Stop #10-32
27	42413	Bracket, Fuse Holder
28	04010-11	Screw, Phillips Washer Head #10-32 x 1-1/2"
29	04031-03	Lockwasher, 5/16" External Tooth
30	04002-12	Bolt, Hex Head M8-1.25 x 20
31	481623	Electronic Module
32	481751	Wire Harness, STT

\* Common hardware which should be purchased locally. All bolts Grade 5 plated, all other fasteners zinc plated.

### ELECTRICAL SYSTEM (KAWASAKI)

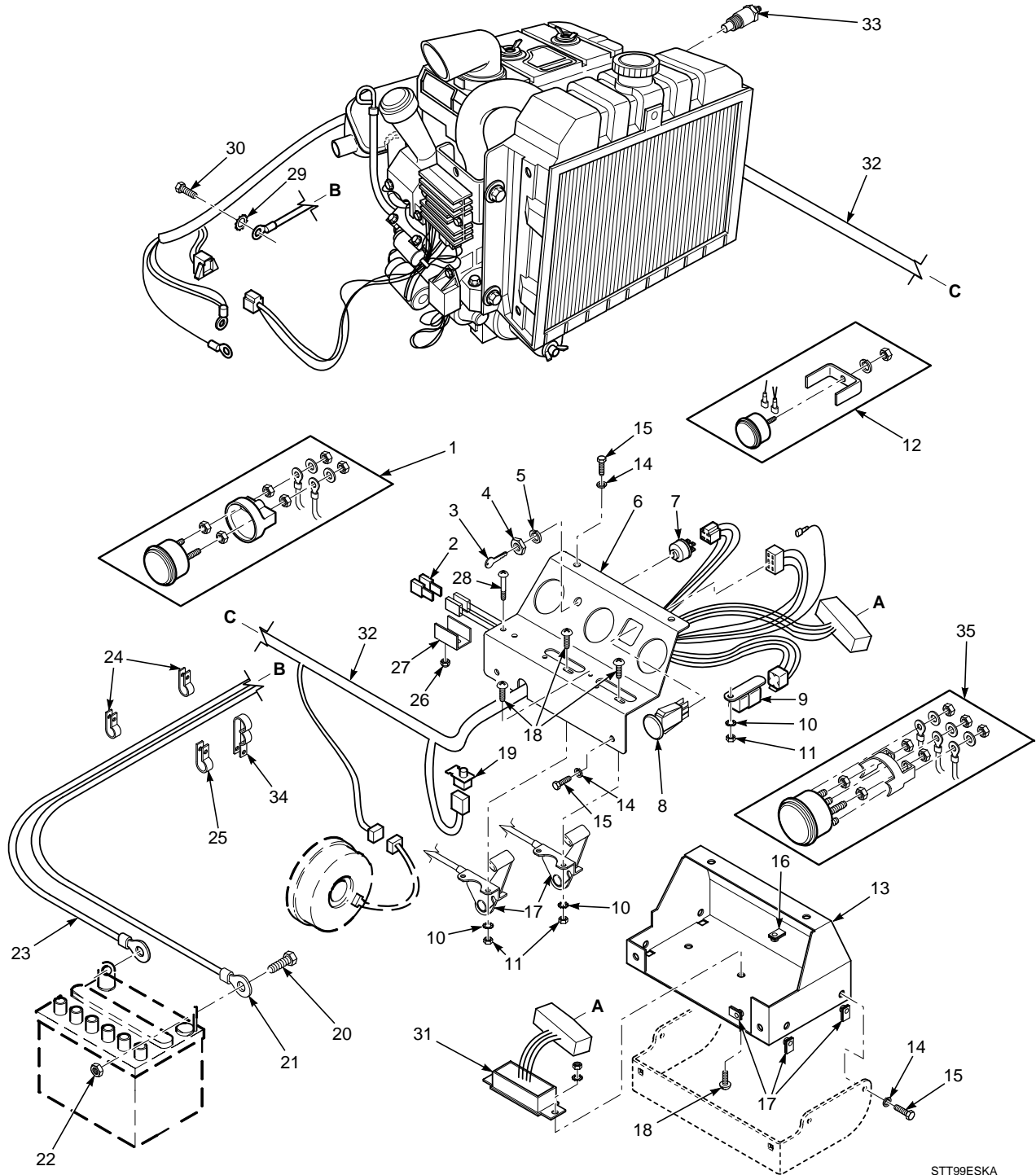

STT99ESKA



## ELECTRICAL SYSTEM (KAWASAKI)

Ref. No.	Part No.	Description
1	48023	Hour Meter
2	48298	Fuse, 20 AMP
3	48017-02	Key & Ring Assembly
4	48017-04	Nut, Hex 5/8-32
5	48017-03	Lockwasher, 5/8" Internal
6	422524	Instrument Panel, Top
7	48798	Key Switch
8	481687	Switch, PTO
9	48788	Relay
10	04031-01	Lockwasher, #10 External Tooth
11	04020-01	Nut, Hex #10-32
12	481755	Ammeter
13	45981	Base, Instrument Panel
14	04030-02	Lockwasher, 1/4"
15	04001-01	Bolt, Hex Head 1/4-20 x 3/4"
16	04110-01	U-Nut, 1/4-20
17	481662	Throttle And Choke Controls
18	04010-01	Screw, Phillips Washer Head #10-32 x 1/2"
19	481638	Switch, Interlock-Seat
20	04001-44	Bolt, Hex Head 1/4-20 x 1/2"
21	48029-12	Cable, Battery - Red 36"
22	04020-02	Nut, Hex 1/4-20
23	48029-07	Cable, Battery - Black
24	48030-09	Clamp, Cable 1/2" ID.
25	48030-10	Clamp, Cable 3/4" ID.
26	04021-01	Nut, Hex Elastic Stop #10-32
27	42413	Bracket, Fuse Holder
28	04010-11	Screw, Phillips Washer Head #10-32 x 1-1/2"
29	04031-03	Lockwasher, 5/16" External Tooth
30	04002-12	Bolt, Hex Head M8-1.25 x 20
31	481668	Electronic Module
32	481752	Wire Harness, STT-KA
33	481670	Sending Unit, Water Temp.
34	48030-11	Clamp, Cable
35	481183	Water Temp. Gauge (STT - KA Only)

\* Common hardware which should be purchased locally. All bolts Grade 5 plated, all other fasteners zinc plated.

### HYDRAULIC PUMP ASSEMBLY

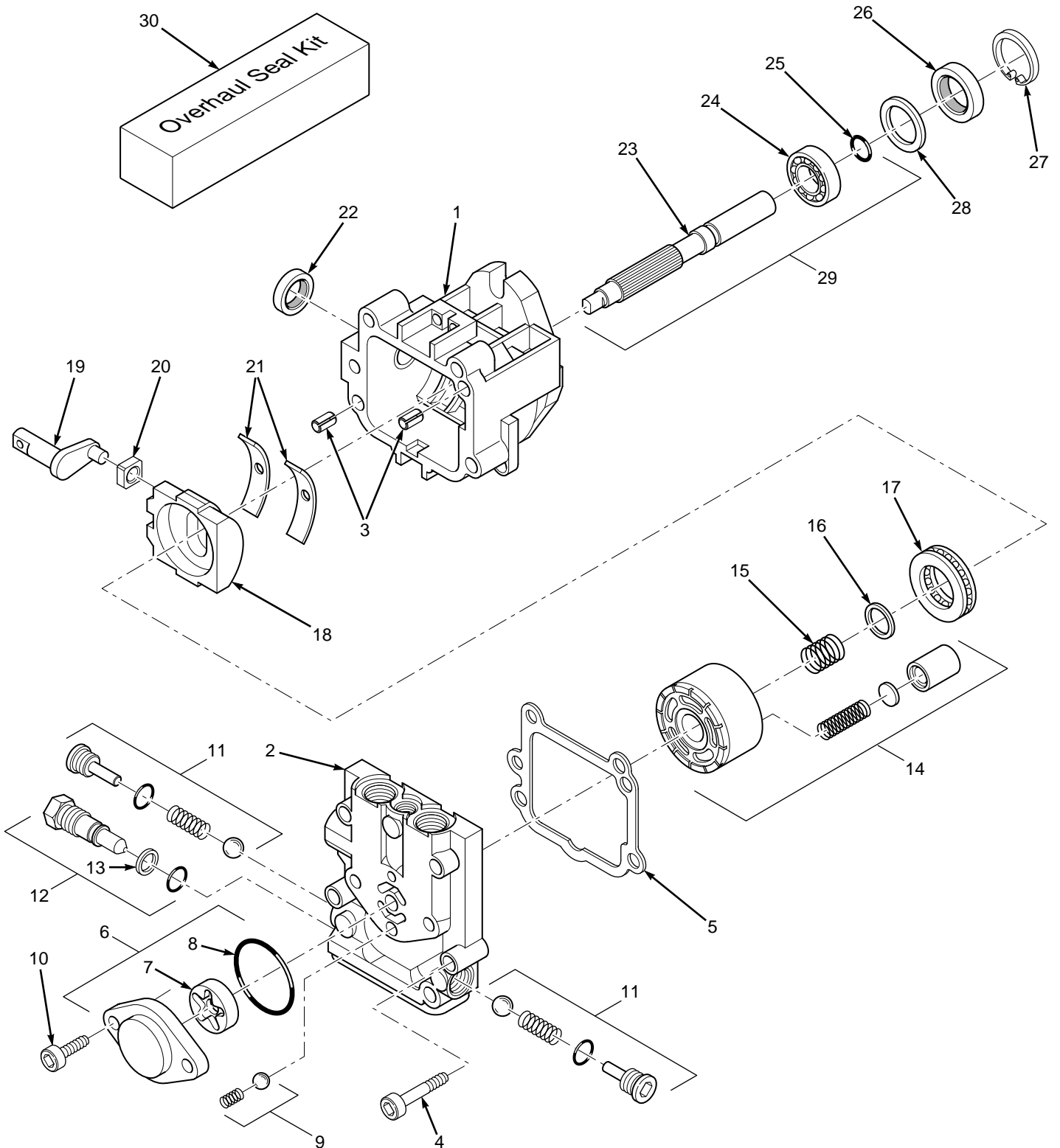

## HYDRAULIC PUMP ASSEMBLY

Ref. No.	Part No.	Description
1	HG 2513017	Housing Kit (Includes Housing, Journal Bearing)
2	HG 2513016	End Cap
3	HG 9004800-2506	Straight Headless Pin
4	HG 9007314-0810	Socket Head Screw
5	HG 2003067	End Cap Gasket
6	HG 2513027	Charge Pump Kit (Includes Charge Cover, Gerotor Assy., O-Ring)
7	HG 50273	Gerotor Assembly
8	HG 9004101-1340	O-Ring
9	HG 2510011	Charge Relief Valve Kit
10	HG 50095	Socket Head Screw
11	HG 2510027	Check Valve Kit (Includes Check Plug, Spring, O-Ring, Orifice Check Valve)
12	HG 2513030	Bypass Valve Kit (Includes Bypass Valve, O-Ring, Back-up Ring)
13	HG 9006110-0120	Backup Ring
14	HG 70079	Cylinder Block Kit
15	HG 2003014	Block Spring
16	HG 2003017	Block Thrust Washer
17	HG 2003044	Roller Thrust Bearing
18	HG 2003087	Swash Plate
19	HG 2003005	Trunnion Arm
20	HG 2000015	Guide Slot
21	HG 2003023	Cradle Bearing
22	HG 9008000-0126	Lip Seal
23	HG 2003020	Pump Shaft
24	HG 2003043	Ball Bearing
25	HG 2003016	Retaining Ring
26	HG 9008000-0128	Lip Seal
27	HG 2003052	Retaining Ring
28	HG 2003018	Spacer
29	HG 2513038	Shaft Kit (Includes Pump Shaft, Ball Bearing, Retaining Ring)
30	HG 2513018	Overhaul Seal Kit (Includes Gasket, Trunnion Seal, Input Shaft Seal, Charge Pump O-Ring)

\* Common hardware which should be purchased locally. All bolts Grade 5 plated, all other fasteners zinc plated.

### REPLACEMENT DECALS AND INFORMATION PLATES



1



2

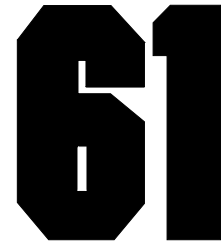

3

48320



4

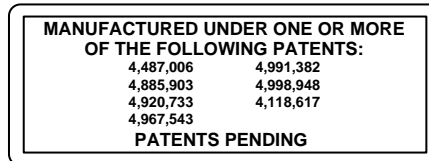

5



6



48072

7



8



9

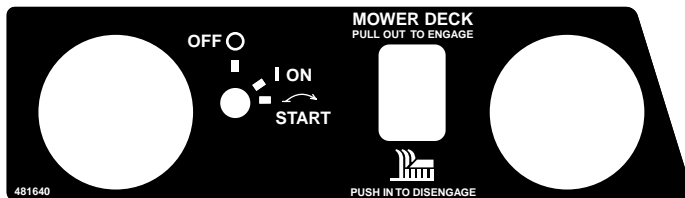

10

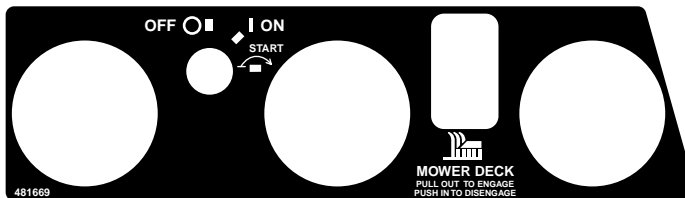

11



12

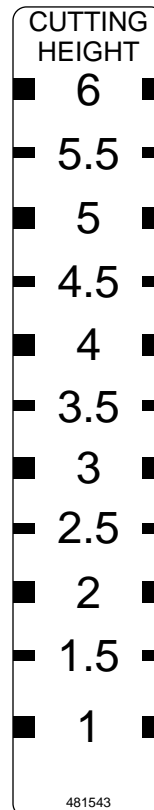

13

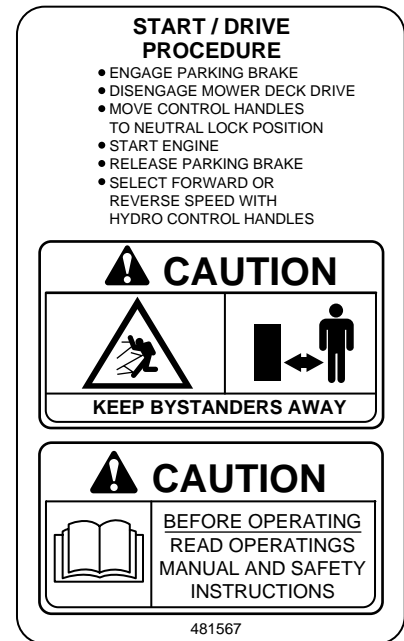

14

# Section 8



## REPLACEMENT DECALS AND INFORMATION PLATES

Ref. No.	Part No.	Description
1	48071	Decal, Danger-Spinning Blades
2	481040	Decal, Warning-Rotating Blades
3	48319	Decal, 52
	48320	Decal, 61
4	481272	Decal, Fuel Tank
5	48656	Decal, Patents
6	481568	Decal, Traction Control
7	48072	Decal, Heavy Duty Commercial
8	48404	Decal, MetalCraft-Made In USA
9	481039	Decal, Belt Cover
10	481640	Decal, Instrument Panel-Upper
11	481669	Decal, Instrument Panel-Upper (Kawasaki)
12	481348	Decal, Instrument Panel-Lower
13	481543	Decal, Cutting Height
14	481567	Decal, Start/Drive Procedure
15	481588	Decal, Seat Support
16	481569	Decal, Turf Tiger
17	481570	Decal, Turf Tiger
18	481664	Decal, Stripes-RH
19	481663	Decal, Stripes-LH
20	481694	Decal, Tiger

\* Common hardware which should be purchased locally. All bolts Grade 5 plated, all other fasteners zinc plated.

**IMPORTANT ADJUSTMENT PROCEDURES**  
**READ OPERATOR'S MANUAL FOR MORE DETAILS**  
 Check tire pressure-  
 (Drive tires - 12 psi,  
 Caster tires - 25 psi)

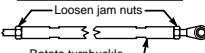
**NEUTRAL ADJUSTMENT**  
 Loosen jam nuts  
  
 Rotate turnbuckle  
 With an operator in the seat, engine running, control levers in neutral and the parking brake disengaged - adjust control linkage. Loosen jam nuts. If wheel rotates forward, adjust turnbuckle CCW. If wheel rotates rearward, adjust turnbuckle CW. Adjust until drive wheel stops turning. Tighten jam nuts. Repeat for opposite side.

**TRACKING ADJUSTMENT**  
 If the machine pulls to the right, adjust LH control linkage CCW to slow left wheel. If the machine pulls to the left, adjust RH control linkage CCW to slow right wheel. Readjust neutral if necessary.

Gearbox lubricant:  
 SAE 80W90 gear oil

**FREE WHEEL OPERATION**  
 To move machine without running the engine, rotate both dump valve levers located at the LH side of the pumps CCW 1/2 turn to "freewheel" positions. Return levers to original position to operate the mower.

**HYDRAULIC TANK FLUID LEVEL**  
 Check hydraulic fluid level daily while fluid is cool. Fluid level should be 3-1/4" below top of filler neck. Fill with SAE 20W50 motor oil only.

**IMPORTANT!**  
 Do not overfill. Room for hot fluid expansion must be allowed or resulting expansion may cause leaks in the system.

481588

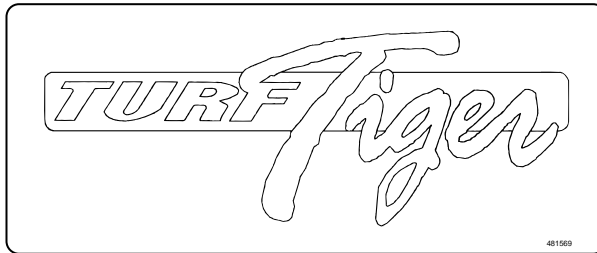

16



17



20

15

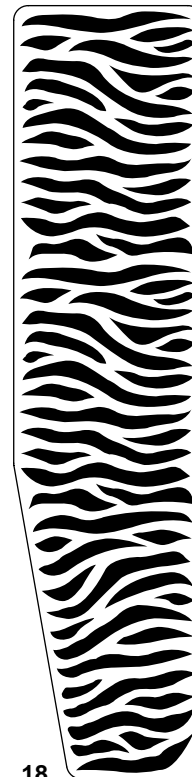

18

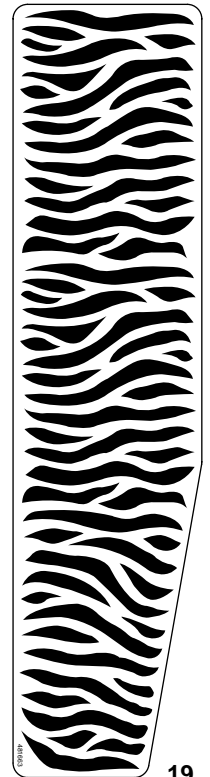

19

390S0173

### ELECTRICAL SCHEMATIC (KOHLER)

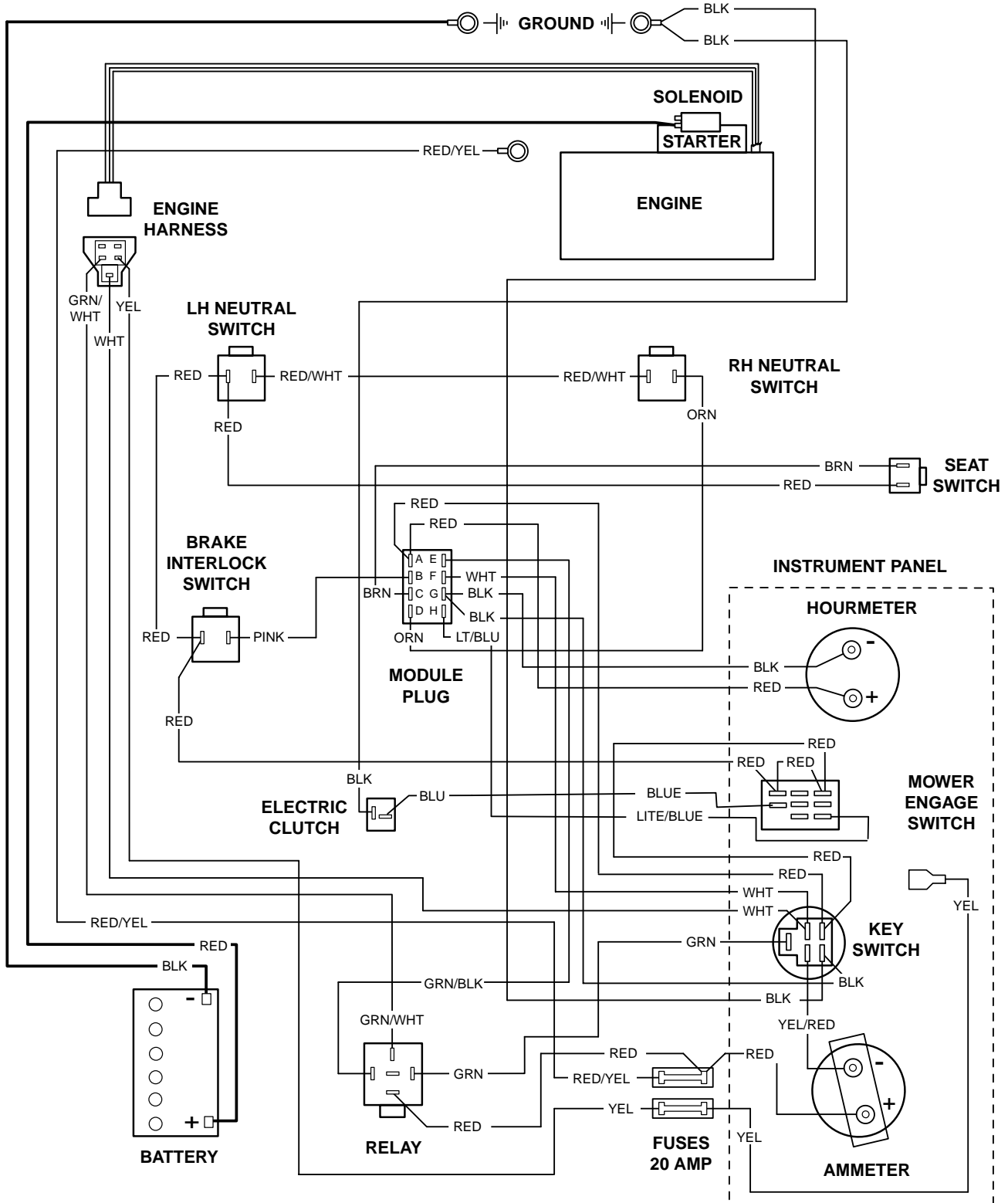

STT99SKH

**ELECTRICAL SCHEMATIC (KAWASAKI)**

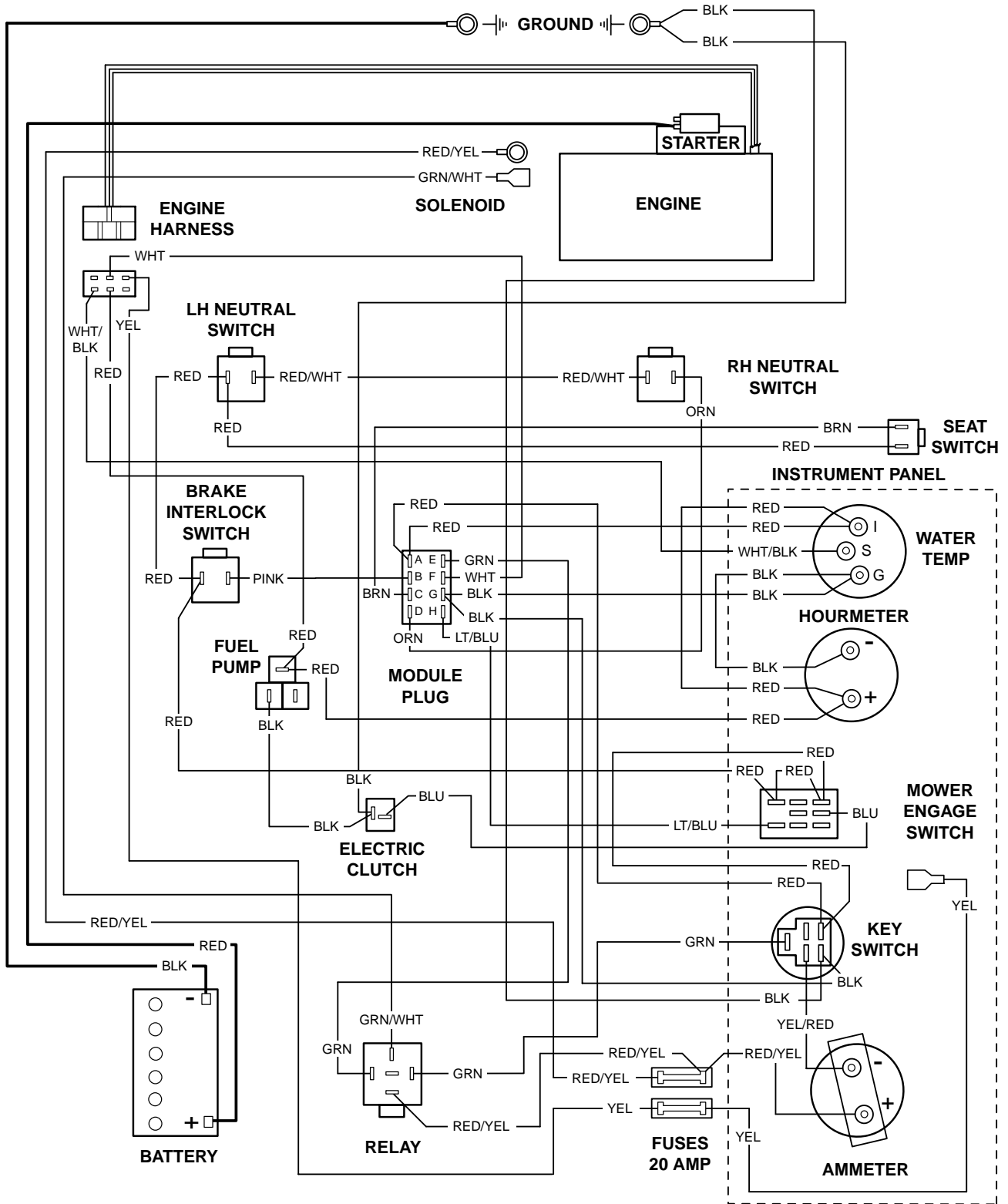

STT99SKA

# LIMITED WARRANTY-COMMERCIAL EQUIPMENT

---

Any part of the Scag commercial mower manufactured by Scag Power Equipment and found, in the reasonable judgment of Scag, to be defective in materials or workmanship, will be repaired or replaced by an Authorized Scag Service Dealer without charge for parts and labor. This warranty is limited to the original purchaser and is not transferable. Proof of purchase will be required by the dealer to substantiate any warranty claims. All warranty work must be performed by an Authorized Scag Service Dealer.

This warranty is limited to the following specified periods from the date of the original retail purchase for defects in materials or workmanship:

- \* Wear items including drive belts, blades, hoses and tires are warranted for 90 days.
- \* Batteries are covered for 90 days.
- \* Frame, deck, and structural components including oil reservoir, fittings, and oil cooler are warranted for 1 year.
- \* Engines and electric starters are covered by the manufacturer's warranty period.
- \* Drive system components are warranted for 1 year by the component manufacturer, in conjunction with Scag Power Equipment. (Excluding fittings, hoses, cooling system, oil reservoir, drive belts).
- \* Electric clutches have a Limited Warranty for 2 year (Parts and labor 1st year; Parts only 2nd year).
- \* Cutter Spindle Assemblies 46631 have a Limited Warranty for three years (Parts and labor 1st year; Parts only 2nd and 3rd year).

Any Scag product used for rental purposes is covered by a 90 day warranty.

The Scag mower, including any defective part must be returned to an Authorized Scag Service Dealer within the warranty period. The expense of delivering the mower to the dealer for warranty work and the expense of returning it to the owner after repair will be paid for by the owner. Scag's responsibility is limited to making the required repairs and no claim of breach of warranty shall be cause for cancellation or rescission of the contract of sale of any Scag mower.

This warranty does not cover any mower that has been subject to misuse, neglect, negligence, or accident, or that has been operated in any way contrary to the operating instructions as specified in the Operator's Manual. The warranty does not apply to any damage to the mower that is the result of improper maintenance, or to any mower or parts that have not been assembled or installed as specified in the Operator's Manual and Assembly Manual. The warranty does not cover any mower that has been altered or modified, changing performance or durability. In addition, the warranty does not extend to repairs made necessary by normal wear, or by the use of parts or accessories which, in the reasonable judgment of Scag, are either incompatible with the Scag mower or adversely affect its operation, performance or durability.

Scag Power Equipment reserves the right to change or improve the design of any mower without assuming any obligation to modify any mower previously manufactured.

All other implied warranties are limited in duration to the one (1) year warranty period or ninety (90) days for mowers used for rental purpose. Accordingly, any such implied warranties including merchantability, fitness for a particular purpose, or otherwise, are disclaimed in their entirety after the expiration of the appropriate one year or ninety day warranty period. Scag's obligation under this warranty is strictly and exclusively limited to the repair or replacement of defective parts and Scag does not assume or authorize anyone to assume for them any other obligation. Some states do not allow limitations on how long an implied warranty lasts, so the above limitation may not apply to you.

Scag assumes no responsibility for incidental, consequential or other damages including, but not limited to, expense for gasoline, expense of delivering the mower to an Authorized Scag Service Dealer and expense of returning it to the owner, mechanic's travel time, telephone or telegram charges, rental of a like product during the time warranty repairs are being performed, travel, loss or damage to personal property, loss of revenue, loss of use of the mower, loss of time or inconvenience. Some states do not allow the exclusion or limitation of incidental or consequential damages, so the above limitation or exclusion may not apply to you.

This warranty gives you specific legal rights, and you may also have other rights which vary from state to state.



**© 1998  
SCAG POWER EQUIPMENT  
DIVISION OF METALCRAFT OF MAYVILLE, INC.**

**PART NO. 03059  
PRINTED 8/98  
PRINTED IN USA**

## Free Manuals Download Website

<http://myh66.com>

<http://usermanuals.us>

<http://www.somanuals.com>

<http://www.4manuals.cc>

<http://www.manual-lib.com>

<http://www.404manual.com>

<http://www.luxmanual.com>

<http://aubethermostatmanual.com>

Golf course search by state

<http://golfingnear.com>

Email search by domain

<http://emailbydomain.com>

Auto manuals search

<http://auto.somanuals.com>

TV manuals search

<http://tv.somanuals.com>