

SCAG[®]

POWER EQUIPMENT

OPERATOR'S MANUAL

V-Ride

Model: SVR36A-20FX
SVR48V-24FX
SVR52V-26FX



Congratulations on owning a Scag mower! This manual contains the operating instructions and safety information for your Scag mower. Reading this manual can provide you with assistance in maintenance and adjustment procedures to keep your mower performing to maximum efficiency. The specific models that this book covers are listed on the inside cover. Before operating your machine, please read all the information enclosed.

© 2010
Scag Power Equipment
Division of Metalcraft of Mayville, Inc.

Part No. 03259
Printed 1/10
Printed in USA



WARNING

FAILURE TO FOLLOW SAFE OPERATING PRACTICES MAY RESULT IN SERIOUS INJURY OR DEATH.

- Read this manual completely as well as other manuals that came with your mower.
- ALWAYS FOLLOW OSHA APPROVED OPERATION.
- DO NOT operate on steep slopes.
- Under no circumstances should the machine be operated on slopes greater than 20 degrees. ALWAYS FOLLOW OSHA APPROVED OPERATION.
- Stay two cut widths away from slopes, drop offs, ditches and retaining walls.
- DO NOT back down a slope or ramp.
- DO NOT mow on wet grass. Wet grass reduces traction and steering control.
- Keep all shields in place, especially the grass discharge chute.
- Before performing any maintenance or service, stop the machine and remove the spark plug wire and ignition key.
- If a mechanism becomes clogged, stop the engine before cleaning.
- Keep hands, feet and clothing away from power-driven parts.
- Keep others off the mower (only one person at a time)

REMEMBER - YOUR MOWER IS ONLY AS SAFE AS THE OPERATOR!

HAZARD CONTROL AND ACCIDENT PREVENTION ARE DEPENDENT UPON THE AWARENESS, CONCERN, PRUDENCE, AND PROPER TRAINING OF THE PERSONNEL INVOLVED IN THE OPERATION, TRANSPORT, MAINTENANCE, AND STORAGE OF THE EQUIPMENT.

This manual covers the operating instructions and illustrated parts list for:

SVR36A-20FX	with a serial number of	E8200041 to E8299999
SVR48V-24FX	with a serial number of	E8300031 to E8399999
SVR52V-26FX	with a serial number of	E8400031 to E8499999

Always use the entire serial number listed on the serial number tag when referring to this product.

Table of Contents

SECTION 1 - GENERAL INFORMATION	1
1.1 INTRODUCTION.....	1
1.2 DIRECTION REFERENCE	1
1.3 SERVICING THE ENGINE AND DRIVE TRAIN COMPONENTS.....	1
1.4 SYMBOLS	2
SECTION 2 - SAFETY INFORMATION	3
2.1 INTRODUCTION.....	3
2.2 SIGNAL WORDS	3
2.3 BEFORE OPERATION CONSIDERATIONS.....	3
2.4 OPERATION CONSIDERATIONS.....	4
2.5 MAINTENANCE CONSIDERATIONS & STORAGE	6
2.6 USING A SPARK ARRESTOR.....	6
2.7 SAFETY AND INSTRUCTIONAL DECALS.....	7
SECTION 3 - SPECIFICATIONS	8
3.1 ENGINE	8
3.2 ELECTRICAL	8
3.3 ENGINE DECK	8
3.4 CUTTER DECK	8
3.5 WEIGHTS AND DIMENSIONS.....	9
3.6 PRODUCTIVITY	9
SECTION 4 - OPERATING INSTRUCTIONS	10
4.1 CONTROLS AND INSTRUMENT IDENTIFICATION	10
4.2 SAFETY INTERLOCK SYSTEM	11
4.3 INITIAL RUN-IN PROCEDURES.....	11
4.4 STARTING THE ENGINE	11
4.5 GROUND TRAVEL AND STEERING	12
4.6 ENGAGING THE DECK DRIVE (CUTTER BLADES).....	13
4.7 HILLSIDE OPERATION.....	14
4.8 PARKING THE MOWER	14
4.9 AFTER OPERATION	14
4.10 REMOVING CLOGGED MATERIAL	14
4.11 MOVING MOWER WITH ENGINE STOPPED.....	15
4.12 RECOMMENDATIONS FOR MOWING	15
4.13 ADJUSTING CUTTING HEIGHT.....	15
SECTION 5 - TROUBLESHOOTING CUTTING CONDITIONS	16

SECTION 6 - ADJUSTMENTS	19
6.1 PARKING BRAKE ADJUSTMENT	19
6.2 TRAVEL ADJUSTMENT.....	19
6.3 THROTTLE CONTROL AND CHOKE ADJUSTMENTS.....	21
6.4 BELT ADJUSTMENTS.....	21
6.5 BELT ALIGNMENT.....	21
6.6 CUTTER DECK ADJUSTMENTS	21
6.7 ELECTRIC CLUTCH ADJUSTMENT	26
6.8 FRONT WEIGHT ADJUSTMENT	26
6.9 OPERATOR CUSHION ADJUSTMENT	27
SECTION 7 - MAINTENANCE.....	29
7.1 MAINTENANCE CHART - RECOMMENDED SERVICE INTERVALS	29
7.2 LUBRICATION.....	30
7.3 HYDRAULIC SYSTEM	32
7.4 ENGINE OIL	33
7.5 ENGINE FUEL SYSTEM	34
7.6 ENGINE AIR CLEANER.....	34
7.7 BATTERY - ELECTRIC START MODELS.....	35
7.8 CUTTER BLADES.....	36
7.9 TIRES.....	37
7.10 BODY AND DECK.....	37
SECTION 8 - ILLUSTRATED PARTS LIST	38
8.1 SCAG APPROVED ATTACHMENTS AND ACCESSORIES.....	38
NOTES.....	39
36A CUTTER DECK.....	40
48V & 52V CUTTER DECKS	42
CUTTER DECK CONTROLS	44
SHEET METAL COMPONENTS	46
STEERING CONTROLS AND FUEL COMPONENTS.....	48
HYDRAULICS AND ENGINE COMPONENTS	50
ELECTRICAL SYSTEM	52
HYDRAULIC PUMP ASSEMBLY	54
REPLACEMENT DECALS AND INFORMATION PLATES	56
SVR ELECTRICAL SCHEMATIC.....	58
LIMITED WARRANTY - COMMERCIAL EQUIPMENT	Following Section 8

GENERAL INFORMATION

1.1 INTRODUCTION

Your mower was built to the highest standards in the industry. However, the prolonged life and maximum efficiency of your mower depends on you following the operating, maintenance and adjustment instructions in this manual.

If additional information or service is needed, contact your Scag Power Equipment Dealer.

We encourage you to contact your dealer for repairs. All Scag dealers are informed of the latest methods to service this equipment and provide prompt and efficient service in the field or at their service shop. They carry a full line of Scag service parts.

- IMPORTANT -

The replacement of any part on this product by other than the manufacturer's authorized replacement part may adversely affect the performance, durability or safety of this product.

Use of other than original Scag replacement parts will void the warranty.

When ordering parts, always give the model and serial number of your mower. The serial number plate is located on the frame of the machine between the engine and transmission where shown in Figure 1-1.

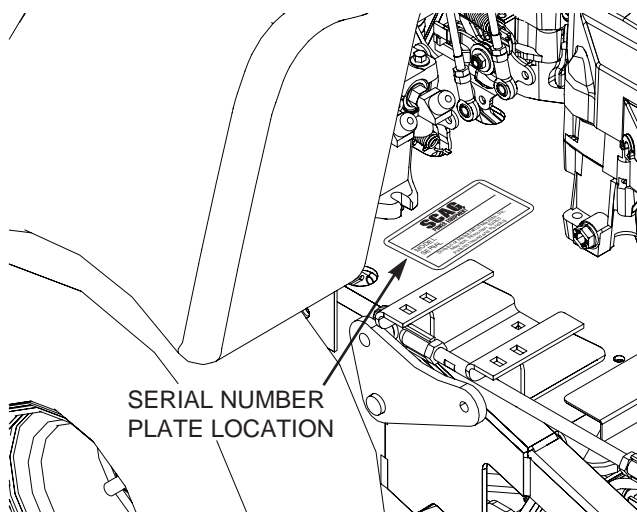

Figure 1-1. Mower Serial Number Plate Location

USE ONLY SCAG APPROVED ATTACHMENTS AND ACCESSORIES.

Attachments and accessories manufactured by companies other than Scag Power Equipment are not approved for use on this machine. See Section 8-1.

WARNING

For pictorial clarity, some illustrations and figures in this manual may show shields, guards or plates open or removed. Under no circumstances should your mower be operated without these devices in place.

All information is based upon product information available at the time of approval for printing. Scag Power Equipment reserves the right to make changes at any time without notice and without incurring any obligation.



















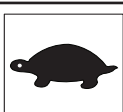

1.2 DIRECTION REFERENCE

The “Right” and “Left”, “Front” and “Rear” of the machine are referenced from the operator’s right and left when in the normal operating position and facing the forward travel direction.

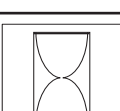
1.3 SERVICING THE ENGINE AND DRIVE TRAIN COMPONENTS

The detail servicing and repair of the engine and transmission are not covered in this manual; only routine maintenance and general service instructions are provided. For service of these components during the limited warranty period, it is important to contact your Scag dealer or find a local authorized servicing agent of the component manufacturer. Any unauthorized work done on these components during the warranty period may void your warranty.

1.4 SYMBOLS

SYMBOL	DESCRIPTION	SYMBOL	DESCRIPTION
	Choke		Transmission
	Parking Brake		Spinning Blade
	On/Start		Spring Tension on Idler
	Off/Stop		Oil
	Falling Hazard		Thrown Object Hazard
	Fast		Slow
	Continuously Variable - Linear		Cutting Element - Basic Symbol
	Pinch Point		Cutting Element - Engage
	Hour meter/Elapsed Operating Hours		Cutting Element - Disengage
	Crush Hazard.		CE Mark
	Thrown Object Hazard Keep Bystanders Away		Read Operator's Manual

SAFETY INFORMATION

2.1 INTRODUCTION

Your mower is only as safe as the operator. Carelessness or operator error may result in serious bodily injury or death. Hazard control and accident prevention are dependent upon the awareness, concern, prudence, and proper training of the personnel involved in the operation, transport, maintenance and storage of the equipment. Make sure every operator is properly trained and thoroughly familiar with all of the controls before operating the mower. The owner/user can prevent and is responsible for accidents or injuries occurring to themselves, other people or property.

READ THIS OPERATOR'S MANUAL BEFORE ATTEMPTING TO START YOUR MOWER.

A replacement manual is available from your authorized Scag Service Dealer or by contacting Scag Power Equipment, Service Department at P.O. Box 152, Mayville, WI 53050 or contact us via the Internet at www.scag.com. The manual for this machine can be downloaded by using the model and serial number or use the contact form to make your request. Please indicate the complete model and serial number of your Scag product when requesting replacement manuals.

2.2 SIGNAL WORDS



This symbol means **“Attention! Become Alert! Your Safety is Involved!”** The symbol is used with the following signal words to attract your attention to safety messages found on the decals on the machine and throughout this manual. The message that follows the symbol contains important information about safety. To avoid injury and possible death, carefully read the message! Be sure to fully understand the causes of possible injury or death.

SIGNAL WORD:

It is a distinctive word found on the safety decals on the machine and throughout this manual that alerts the viewer to the existence and relative degree of the hazard.

DANGER

The signal word “DANGER” denotes that an extremely hazardous situation exists on or near the machine that could result in high probability of death or irreparable injury if proper precautions are not taken.

WARNING

The signal word “WARNING” denotes that a hazard exists on or near the machine that can result in injury or death if proper precautions are not taken.

CAUTION

The signal word “CAUTION” is a reminder of safety practices on or near the machine that could result in personal injury if proper precautions are not taken.

Your safety and the safety of others depends significantly upon your knowledge and understanding of all correct operating practices and procedures of this machine.

2.3 BEFORE OPERATION CONSIDERATIONS

1. NEVER allow children to operate this mower. Do not allow adults to operate this machine without proper instructions.
2. Do not mow when children and/or others are present. Keep children out of the mowing area and in the watchful care of a responsible adult other than the operator. Be alert and turn machine off if a child enters the area.
3. DO NOT allow children to ride or play on the machine, it is not a toy.
4. Clear the area to be mowed of objects that could be picked up and thrown by the cutter blades.
5. DO NOT carry passengers.
6. DO NOT operate the machine under the influence of alcohol or drugs.

7. If the operator(s) or mechanic(s) cannot read English or Spanish, it is the owner's responsibility to explain this material to them.
8. DO NOT wear loose fitting clothing. Loose clothing, jewelry or long hair could get tangled in moving parts. Do not operate the machine wearing shorts; always wear adequate protective clothing including long pants. Wearing safety glasses, safety shoes and a helmet is advisable and is required by some local ordinances and insurance regulations.

WARNING

Always wear hearing protection. Operating this machine over prolonged periods of time can cause loss of hearing.

9. Keep the machine and attachments in good operating condition. Keep all shields and safety devices in place. If a shield, safety device or decal is defective or damaged, repair or replace it before operating the machine.

WARNING

This machine is equipped with an interlock system intended to protect the operator and others from injury. This is accomplished by preventing the engine from starting unless the deck drive is disengaged, the neutral lock lever is in the neutral lock position, and the operator is in the operating position. The system shuts off the engine if the operator steps off the operator platform with the deck drive engaged or if the neutral lock lever is placed in the drive position (D) and the parking brake is applied. Never operate equipment with the interlock system disconnected or malfunctioning.

10. Be sure the interlock switches are functioning correctly.
11. Fuel is flammable; handle it with care. Fill the fuel tank outdoors. Never fill it indoors. Use a funnel or spout to prevent spillage. Clean up any spillage before starting the engine.
12. DO NOT add fuel to a running or hot engine. Allow the engine to cool for several minutes before adding fuel. Never fuel indoors or inside enclosed trailers.

13. Keep flammable objects (cigarettes, matches, etc.), open flames and sparks away from the fuel tank and fuel container. Use only approved containers.
14. Equipment must comply with the latest requirements per SAE J137 and/or ANSI/SAE S279 when driven on public roads.
15. Do not operate without the side discharge chute installed and in the down position or with an optional grass catcher or mulch plate completely installed.
16. Check the blade mounting bolts at frequent intervals for proper tightness.
17. Make sure all hydraulic fluid connections are tight and all hydraulic hoses and lines are in good condition before starting the machine.

2.4 OPERATION CONSIDERATIONS

1. Know the function of all controls and how to stop quickly.

WARNING

DO NOT operate on steep slopes. Under no circumstances should the machine be operated on slopes greater than 20 degrees. ALWAYS FOLLOW OSHA APPROVED OPERATION.

2. Reduce speed and exercise extreme caution on slopes and in sharp turns to prevent tipping or loss of control. Be especially cautious when changing directions on slopes.
3. Stay two cut widths away from slopes, drop offs, ditches and retaining walls.
4. To prevent tipping or loss of control, start and stop smoothly, avoid unnecessary turns and travel at reduced speed.
5. When using any attachment, never direct the discharge of material toward bystanders or allow anyone near the machine while in operation.
6. Start the engine with the operator in the operating position, cutter blades are disengaged, parking brake is engaged, and the neutral lever is in neutral.
7. If the mower discharge ever plugs, shut off the engine, remove the ignition key, and wait for all movement to stop before removing the obstruction.

Section 2

WARNING

DO NOT use your hand to dislodge the clogged discharge chute. Use a stick or other device to remove clogged material after the engine has stopped running and the blades have stopped turning.

8. Be alert for holes, rocks, roots and other hidden hazards in the terrain. Keep away from any drop offs. Beware of overhead obstructions (low limbs, etc.), underground obstacles (sprinklers, pipes, tree roots, etc.). Cautiously enter a new area. Be alert for hidden hazards.
9. Disengage power to cutter deck before backing up. Do not mow in reverse unless absolutely necessary and then only after observation of the entire area behind the mower. If you must mow in reverse, maintain a constant lookout to the rear of the machine and mow slowly.
10. DO NOT turn sharply. Use care when backing up.
11. Disengage power to cutter deck before crossing roads, walks or gravel drives.
12. Mow only in daylight or good artificial light.
13. NEVER raise the deck with the blades engaged.
14. Take all possible precautions when leaving the machine unattended, such as disengaging the mower, stopping the engine, and removing the key.
15. Disengage power to the attachments when transporting or when not in use.
16. The machine and attachments should be stopped and inspected for damage after striking a foreign object, and damage should be repaired before restarting and operating the machine.

CAUTION

Do not touch the engine or the muffler while the engine is running or immediately after stopping. These areas may be hot enough to cause a burn.

DANGER

DO NOT run the engine inside a building or a confined area without proper ventilation. Exhaust fumes are hazardous and contain carbon monoxide which can cause brain injury and death.

17. Keep hands and feet away from cutter blades and moving parts. Contact can injure.
18. Transport the mower using a heavy duty trailer or truck. Insure the trailer or truck has all of the necessary lighting and markings as required by laws, codes, and ordinances. Secure a trailer with a safety chain.
19. Be cautious when loading and unloading onto trailers or trucks. Use only a full width ramp. Always back on and drive off a trailer.
20. When transporting the mower, make sure the neutral lock lever is in neutral lock, the engine is off with the key removed, the parking brake is engaged and the wheels have been blocked.
21. Tie the mower down securely using the tie down points located on the front and rear of the machine. See Figure 2-1 and 2-2. Secure using straps, chains, cable, or ropes. Both front and rear straps must be directed down and outward from machine.

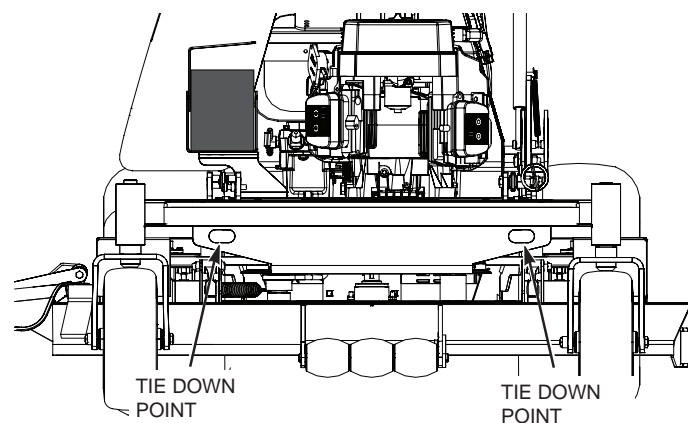

Figure 2-1. Front Tie Down Points

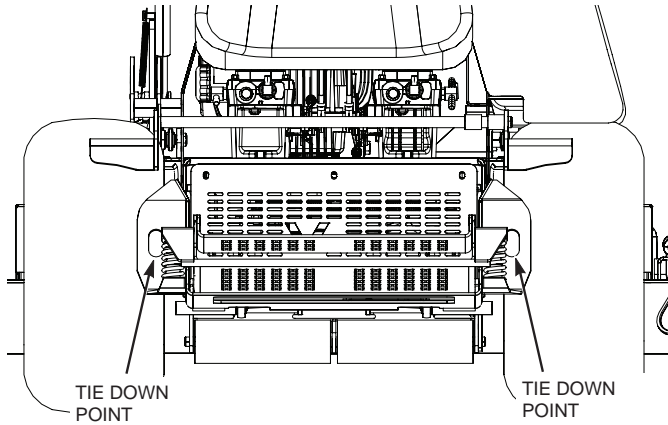

Figure 2-2. Rear Tie Down Points

22. Use care when approaching blind corners, shrubs, trees, or other objects that may obscure vision.
23. NEVER leave the machine running unattended.

2.5 MAINTENANCE CONSIDERATIONS & STORAGE

1. Never make adjustments to the machine with the engine running unless specifically instructed to do so. If the engine is running, keep hands, feet, and clothing away from moving parts.
2. Place the neutral lock lever in neutral lock, engage the parking brake, stop engine and remove key or disconnect spark plug wire to prevent accidental starting of the engine when servicing or adjusting the machine. Wait for all movement to stop before adjusting, cleaning or repairing.
3. Remove spark plug wire before making any repairs.
4. Keep all nuts, bolts and screws tight, to ensure the machine is in safe working condition. Check blade mounting bolts frequently to be sure they are tight.
5. Do not change the engine governor settings or overspeed the engine. See the engine operator's manual for information on engine settings.
6. To reduce fire hazard, keep the cutting units, drives, muffler and engine free of grass, leaves, excessive grease, oil and dirt.
7. Park the machine on level ground.
8. NEVER allow untrained personnel to service the machine.
9. Use care when checking blades. Use a Blade Buddy, wrap the blade(s) or wear gloves and USE CAUTION

when servicing blades. Only replace blades. NEVER straighten or weld blades.

10. Keep all parts in good working condition. Replace all worn or damaged decals.
11. Use jack stands to support components when required.
12. Carefully release pressure from components with stored energy.

WARNING

Hydraulic fluid is under high pressure. Keep body and hands away from pin holes or nozzles that eject hydraulic fluid under high pressure. If you need service on your hydraulic system, please see your authorized Scag dealer. If hydraulic fluid is injected into the skin, it must be surgically removed within a few hours by a doctor or gangrene may result.

13. Let the engine cool before storing.
14. DO NOT store the machine near an open flame.
15. Shut off fuel while storing or transporting.
16. DO NOT store fuel near flames or drain indoors.

2.6 USING A SPARK ARRESTOR

The engine in this machine is not equipped with a spark arrestor muffler. It is in violation of California Public Resource Code Section 4442 to use or operate this engine on or near any forest covered, brush covered or grass covered land unless the exhaust system is equipped with a spark arrestor meeting any applicable local or state laws. Other states or federal areas may have similar laws. Check with your state or local authorities for regulations pertaining to these requirements.

Section 2

2.7 SAFETY AND INSTRUCTIONAL DECALS

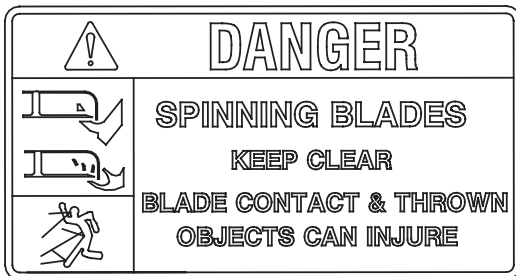

483407

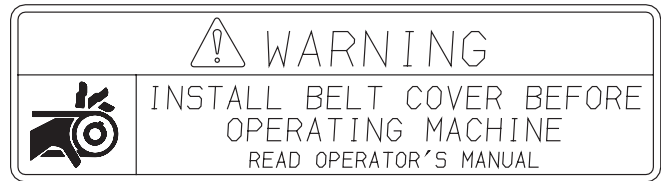

483402

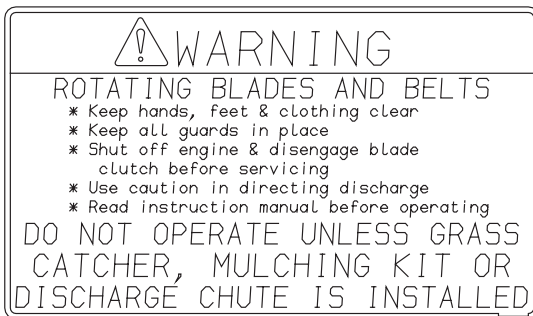

483406

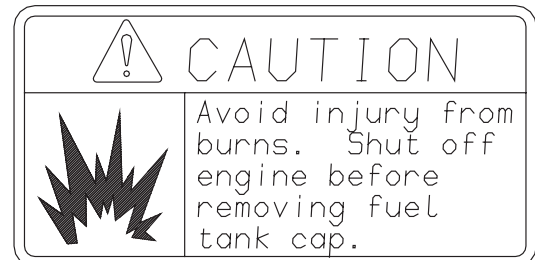

483397

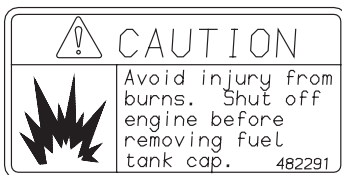

482291

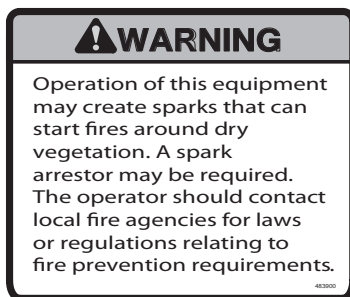

483900

(supplied with California models only)

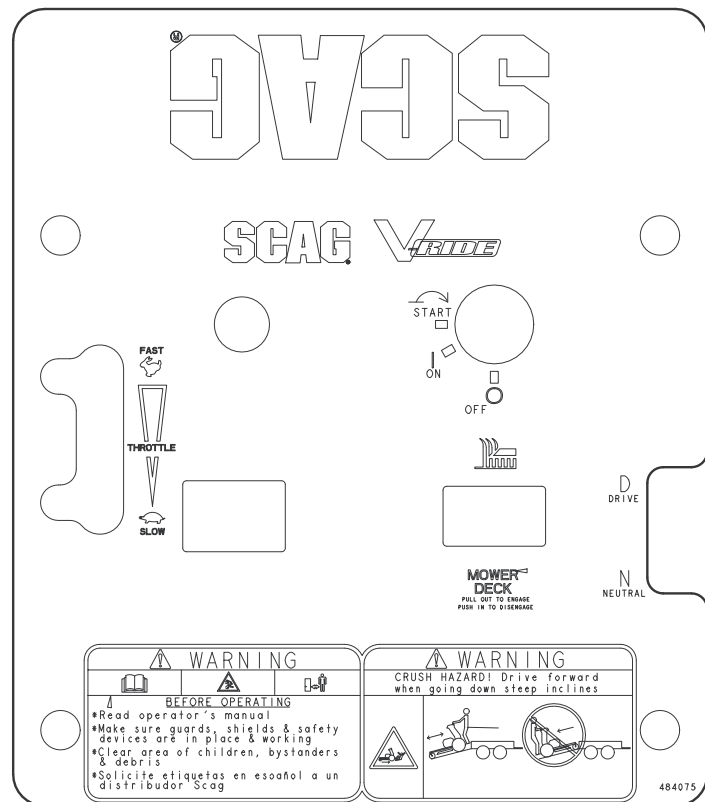

484075

484075



483405

Section 3

True Cutting Width:	
36	35.5" (90.2 cm)
48	48" (122.0 cm)
52	52" (132.0 cm)
Cutting Height Adjustment.....	Adjustment from, 1-1/2" to 4-1/2" in 1/4" increments
Cutter Blades.....	0.197 in. Thick, Milled Edge, Wear Resistant Marbain™
Blade Engagement.....	Electric Blade Engagement Clutch with Control Panel Switch Connected to the Cutter Deck through a Belt.
Discharge Opening.....	Extra Wide Discharge Opening with Spring-Loaded Discharge Chute
Discharge Chute.....	Black, Polypropylene (Plastic), Flexible
Spindles.....	Cast-Iron Housing, Tapered Roller Bearings with Top Access Grease Fitting and Grease Overfill Relief Poppet
Spindle Pulleys.....	Split Steel with Tapered Locking Hub
Cutter Deck Belts.....	B-section with Kevlar Cords
Electric Clutch Type.....	Ogura Heavy Duty PTO Clutch Brake

3.5 WEIGHTS AND DIMENSIONS

	SVR-36A	SVR-48V	SVR-52V
Length (with foot plate down).....	71"	69-1/2"	71-3/4"
Length (with foot plate in transport position).....	67"	65-1/2"	67-3/4"
Tracking Width.....	35-1/2"	41-3/4"	41-3/4"
Overall Width w/chute down.....	47-3/4"	61-1/4"	65-1/4"
Overall Width w/chute up.....	37-1/4"	49-3/4"	53-3/4"
Overall Height.....	46-1/2"	47-1/2"	47-1/2"
Operating Weight.....	775#	860#	860#

3.6 PRODUCTIVITY

	36	48	52
Cutting Width	36"	48"	52"
Acres Per Day	14	18.6	20.2

The preceding chart will aid you in determining how many acres your Scag mower will cut per day. The chart is an estimate based on 8 hours per day cutting time at 6 MPH with a 20% allowance for overlap and turns.

OPERATING INSTRUCTIONS

CAUTION

Do not attempt to operate this mower unless you have read this manual. Learn the location and purpose of all controls and instruments before you operate this mower.

4.1 CONTROLS AND INSTRUMENT IDENTIFICATION

Before operating the mower, familiarize yourself with all mower and engine controls. Knowing the location, function and operation of these controls is important for safe and efficient operation of the mower.

1. **Ignition Switch (Figure 4-1).** The ignition switch is used to start the engine and has three positions; OFF, ON, and START.

2. **Mower Deck Switch (Figure 4-1).** Used to engage and disengage the mower drive system. Pulling up on the switch will engage the deck drive. Pushing down on the switch will disengage the deck drive.
3. **Engine Choke Control (Figure 4-1).** Used to start a cold engine.
4. **Engine Throttle Control (Figure 4-1).** Used to control the engine speed. Pushing the lever forward increases engine speed. Pulling the lever back decreases engine speed. Full back position is the IDLE position. Full forward is the cutting position.
5. **Hourmeter (Figure 4-1).** Indicates the number of hours the engine has been operated. It operates whenever the engine is running. Has preset maintenance reminders for engine and hydraulic system oil changes. Will start flashing scheduled maintenance 2 hours before preset time and continue flashing until 2 hours after. Automatically resets.

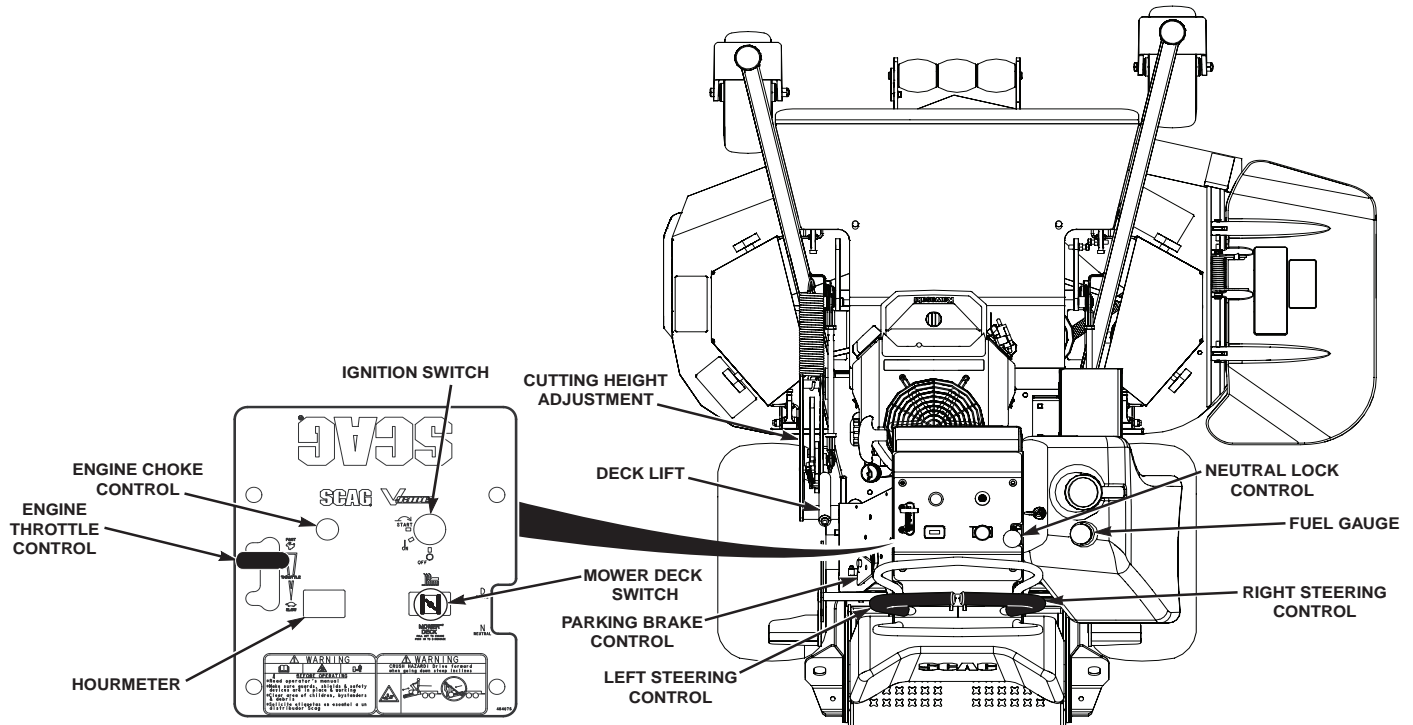

Figure 4-1. Controls and Instruments

Section 4

6. **Left Steering Control (Figure 4-1).** Used to control the mower's left wheel when traveling forward or reverse. See Section 4.5 for further details regarding the mower's travel controls.
7. **Right Steering Control (Figure 4-1).** Used to control the mower's right wheel when traveling forward or reverse. See Section 4.5 for further details regarding the mower's travel controls.
8. **Neutral Lock Lever (Figure 4-1).** Used to disengage the mower drive in the neutral lock position (N) or to engage to the mower's drive in the drive position (D). See Section 4.5 for further details regarding the mower's travel controls.
9. **Parking Brake Control (Figure 4-1).** Used to engage and disengage the parking brakes. Pull the lever back to engage the parking brakes. Push the lever forward to disengage the parking brakes.
10. **Deck Lift Lever (Figure 4-1).** Used to raise and lower the cutter deck.
11. **Cutting Height Adjustment (Figure 4-1).** Used to set the cutter deck at the desired cutting height.
12. **Fuel Tank Gauge (Figure 4-1).** Indicates the amount of fuel in the fuel tank.

4.2 SAFETY INTERLOCK SYSTEM

The mower is equipped with an interlock system intended to protect the operator and others from injury. This is accomplished by preventing the engine from starting unless the deck drive is disengaged, the neutral lock lever is in the neutral lock position, and the operator is in the operating position. The system shuts off the engine if the operator steps off the operator platform with the deck drive engaged or if the neutral lock lever is placed in the drive position (D) and the parking brake is applied. Never operate equipment with the interlock system disconnected or malfunctioning.

WARNING

Never operate the mower with the interlock system disconnected or malfunctioning. Do not disengage or bypass any switch; injury to yourself and others or property damage could result.

4.3 INITIAL RUN-IN PROCEDURES

FIRST DAY OF USE OR APPROXIMATELY 20 HOURS

1. Check all belts for proper alignment and wear at 2, 4 and 8 hours.
2. Change the engine oil and oil filter after the first 20 hours of operation. See Section 7.4.
3. Check oil level in the hydraulic system reservoir. See Section 7.3
4. Check for loose hardware. Tighten as needed.
5. Check interlock system for proper operation. See Section 4.2.
6. Check tire pressure. Adjust pressure if necessary. See Section 7.10.

4.4 STARTING THE ENGINE

CAUTION

DO NOT USE STARTING FLUIDS. Use of starting fluids in the air intake system may be potentially explosive or cause a "runaway" engine condition that could result in engine damage and/or personal injury.

1. Be sure the fuel shutoff valve, located by the fuel tank, is completely open. See Section 7.5.
2. Place the neutral lock lever in the neutral position and disengage the the cutter blades .
3. Engage the parking brake.
4. If the engine is cold, choke the engine as needed.
5. Move the engine throttle control to about half engine speed.
6. Turn the ignition key to the start position and start the engine.
7. Allow engine to warm before operating the mower.

4.5 GROUND TRAVEL AND STEERING

- IMPORTANT -

If you are not familiar with the operation of a machine with lever steering and/or hydrostatic transmissions, the steering and ground speed operations should be learned and practiced in an open area, away from buildings, fences, or obstructions. Practice until you are comfortable with the handling of the machine before attempting to mow. Learn the operation on flat ground before operating on slopes.

- IMPORTANT -

Start practicing with a slow engine speed and slow forward travel.

Learn to feather the steering controls to obtain a smooth operating action.

Practice operating the mower until you are comfortable with the controls before proceeding to mow.

FORWARD TRAVEL

To travel forward with the mower, disengage the parking brake, place the neutral lock lever in the drive (D) position and slowly push the steering control levers forward an equal distance. The further the steering control levers are pushed forward, the greater the forward speed will be. To increase the speed, push the steering control levers forward and to decrease speed, pull the steering control levers back. See Figure 4-2.

To stop the forward travel completely, pull the steering control levers back to the neutral position.

To steer the mower to the left while traveling forward, pull the left steering control lever back. The further the steering control is pulled back, the quicker the mower will turn left. See Figure 4-3.

To steer the mower to the right while traveling forward, pull the right steering control lever back. The further the steering control is pulled back, the quicker the mower will turn right. See Figure 4-3.

- NOTE -

Smooth operation of the steering control levers will produce smooth mower operation. While learning the operation of the steering controls, keep the travel speed low.

REVERSE TRAVEL

CAUTION

Disengage power to the mower before backing up. Do not mow in reverse unless absolutely necessary and then only after observation of the entire area behind the mower.

CAUTION

Before backing up, observe the rear for persons and obstructions. Clear the area before backing up. Possible injury or property damage could occur.

To travel in reverse, pull both steering control handles back. Keep the travel speed low while traveling in reverse.

- NOTE -

The mower may not travel straight in reverse. Slight adjustments may need to be made using the steering controls.

To steer left while traveling in reverse, allow the left steering control lever to move forward. The further the control is allowed to move forward, the quicker the mower will turn left.

To steer right while traveling in reverse, allow the right steering control lever to move forward. The further the control is allowed to move forward, the quicker the mower will turn right.

To stop the reverse travel, allow the steering control levers to return to the neutral position. If the mower is to be parked, engage the parking brake and place the neutral lock lever in the neutral (N) position.

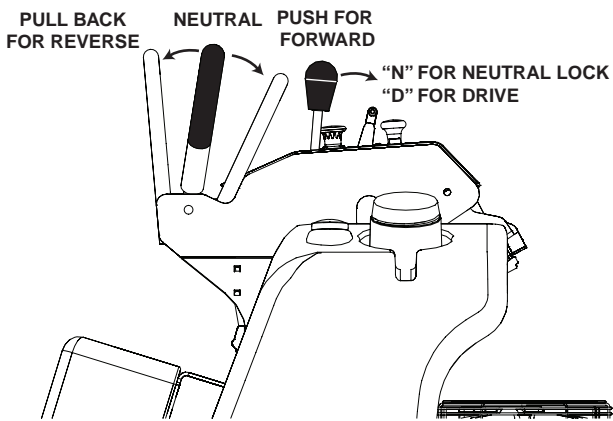
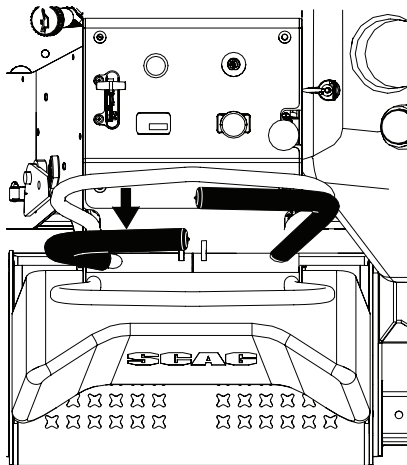

Figure 4-2. Forward / Reverse Controls

4.6 ENGAGING THE DECK DRIVE (CUTTER BLADES)

1. Set the throttle at about 3/4 speed. Do not attempt to engage the deck drive at high speed as this shortens the electric clutch life — use only moderate engine speed when engaging the deck drive.
2. Engage the deck drive by pulling up on the yellow switch, located on the instrument panel, to the engage position. See Figure 4-2.



WHILE TRAVELING FORWARD, PULL BACK ON LEFT STEERING CONTROL TO STEER LEFT

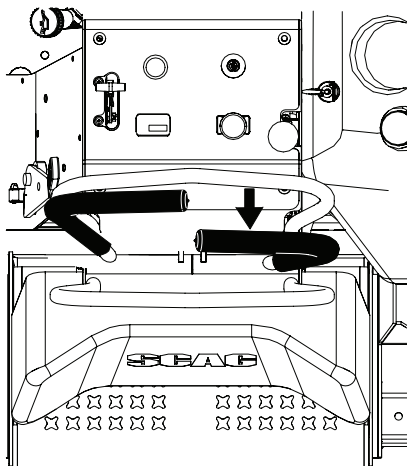

WHILE TRAVELING FORWARD, PULL BACK ON RIGHT STEERING CONTROL TO STEER RIGHT

Figure 4-3. Steering Controls

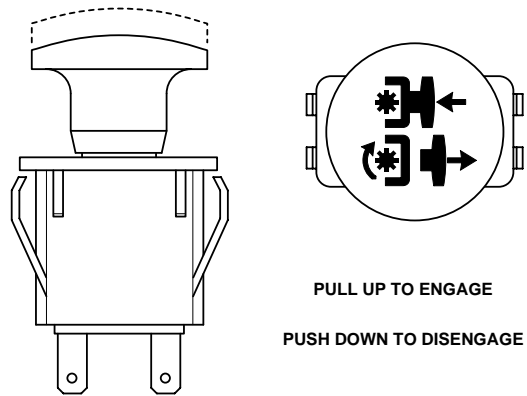

390S0138

Figure 4-4. Cutter Engage Switch

⚠ CAUTION

Disengage power to the mower before backing up. Do not mow in reverse unless absolutely necessary and then only after observation of the entire area behind the mower.

⚠ CAUTION

Before backing up, observe behind the mower for persons and obstructions. Clear the area before backing up. Possible injury or property damage could occur.

- NOTE -

A squealing noise may be heard when engaging or disengaging the deck drive. It is caused by the electric clutch plates meshing as the mower comes up to speed. This is normal.

3. To disengage the deck drive, push the switch in to the disengage position.
4. Always operate the engine at full throttle to properly maintain cutting speed. If the engine starts to lug down, reduce the forward speed and allow the engine to operate at maximum RPM.

4.7 HILLSIDE OPERATION

WARNING

DO NOT operate on steep slopes. Under no circumstances should the machine be operated on slopes greater than 20 degrees. ALWAYS FOLLOW OSHA APPROVED OPERATION.

1. This mower has been designed for good traction and stability under normal mowing conditions. However, caution must be used when traveling on slopes, especially when the grass is wet. Wet grass reduces traction and steering control.
2. Stay two cut widths away from slopes, drop offs, ditches and retaining walls.
3. To prevent tipping or loss of control, do not start or stop suddenly, avoid unnecessary turns and travel at reduced speed. If tires lose traction, disengage blades and proceed slowly off the slope.
4. Avoid sudden starts when mowing uphill. Sudden starts may cause the machine to tip backwards.
5. Loss of traction may occur when traveling down hill. Weight transfers to the front of the machine and may cause the drive wheels to slip causing loss of braking or steering.
6. Never back down hill.
7. Keep tires properly inflated.

4.8 PARKING THE MOWER

1. Park the machine on a flat, level surface only. Do not park the machine on an incline.
2. Disengage the cutter blades.
3. Shift the neutral lock lever into the neutral (N) position.
4. Engage the parking brake.
5. Slow the engine to idle speed.
6. Turn the ignition key to the OFF position and remove the key.

4.9 AFTER OPERATION

1. Wash the entire mower after each use. Do not use high pressure spray or direct the spray onto electrical components.

- IMPORTANT -

Do not wash a hot or running engine. Cold water will damage the engine. Use compressed air to clean the engine if it is hot.

2. Keep the entire mower clean to inhibit serious heat damage to the engine or hydraulic oil circuit.
3. Check the drive belts for proper alignment and any signs of wear. Correct and adjust if necessary.

DANGER

To avoid injury from burns, allow the mower to cool before removing the fuel tank cap and refueling.

4. After the mower has cooled down, fill the fuel tank with fresh, clean fuel at the end of every day of operation. See Engine Owner's Manual for proper octane requirements.
5. Check the tire pressure. Adjust pressure if necessary.

4.10 REMOVING CLOGGED MATERIAL

DANGER

ROTATING BLADES

NEVER PUT YOUR HANDS INTO THE DISCHARGE CHUTE FOR ANY REASON!

Shut off the engine and remove the key and only then use a stick or similar object to remove material if clogging has occurred.

1. If the discharge chute becomes clogged, shut off the engine and remove the ignition key. Using a stick or similar item, dislodge the clogged material. Then resume normal mowing.

Section 4

4.11 MOVING MOWER WITH ENGINE STOPPED

To “free-wheel” or move the mower around without the engine running, place the dump valve levers in the FREE-WHEEL position. Disengage the parking brake and move the mower by hand. The dump valve levers must be returned to the DRIVE position and torqued to 7-10 ft/lbs to drive the mower.

4.12 RECOMMENDATIONS FOR MOWING

1. Do not mow with dull blades. A dull blade will tear grass, resulting in poor lawn appearance and reduced mowing power.

! WARNING

DO NOT operate without Discharge Chute, Mulching Kit, or entire Grass Catcher properly installed.

2. The discharge chute must not be removed and must be kept in the lowest position to deflect grass clippings and thrown objects downward. Direct the side discharge away from sidewalks or streets to minimize cleanup of clippings. When mowing close to obstacles, direct the discharge away from the obstacles to reduce the chance of property damage by thrown objects.
3. Cut grass when it is dry and not too tall. Do not cut grass too short (cut off 1/3 or less of existing grass for best appearance). Mow frequently.
4. Keep mower and discharge chute clean.
5. When mowing wet or tall grass, mow the grass twice. Raise the mower to the highest setting for the first pass and then make a second pass to the desired height.
6. Use a slow travel speed for trimming purposes.
7. Operate the engine at full throttle for best cutting. Mowing with a lower RPM causes the mower to tear the grass. The engine is designed to be operated at full speed.
8. Use the alternate stripe pattern for best lawn appearance. Vary the direction of the stripe each time the grass is mowed to avoid wear patterns in the grass.

4.13 ADJUSTING CUTTING HEIGHT

The mower deck can be adjusted from a height of 1-1/2 inch to 4-1/2 inches at 1/4-inch intervals. To adjust the cutting height:

! WARNING

DO NOT adjust the cutting height with the mower blades rotating. Disengage the power to the cutter blades, put the neutral lock lever in the neutral position, apply the parking brake and then adjust cutting height.

1. Disengage the power to the cutter blades.
2. Pull on the cutter deck lift lever all the way backward until it locks in place. See Figure 4-5.
3. Insert the lanyard pin into the cutting height index at the desired cutting height. Pull backward on the cutter deck lift lever, push and hold the lock button See Figure 4-5. Slowly release the cutter deck lift lever. A deck height decal is located on the cutting height index as an aid in adjusting the deck to the desired height.

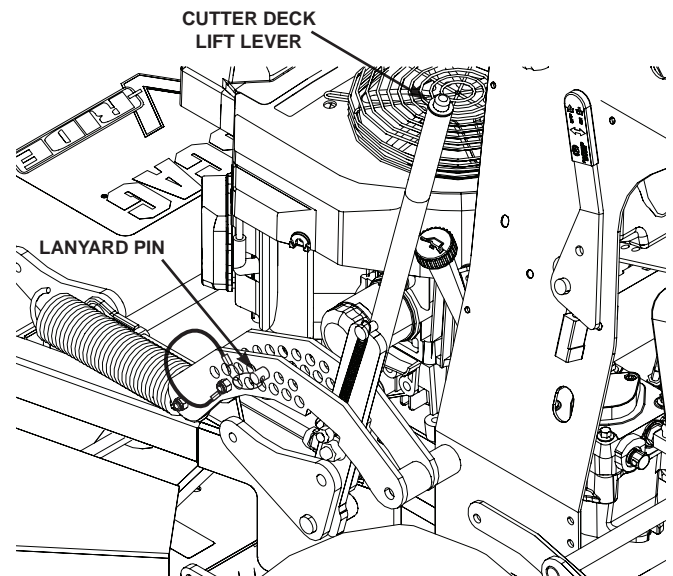
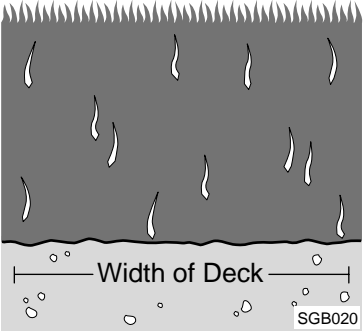
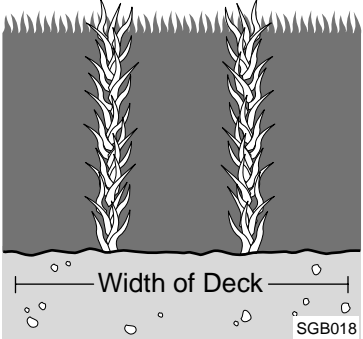
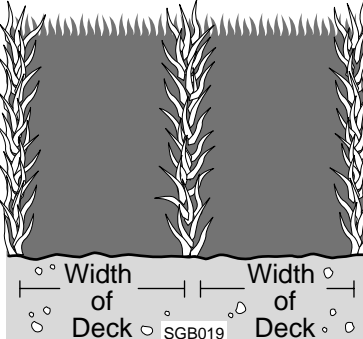
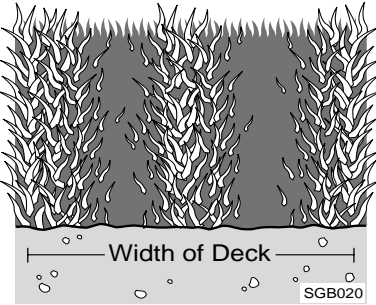
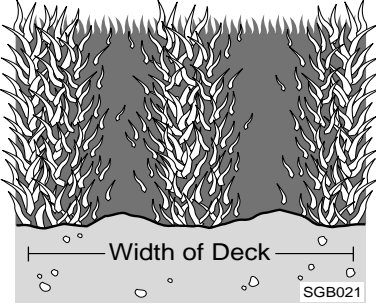
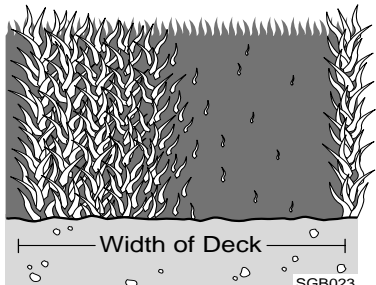

Figure 4-5. Adjusting Cutting Height

TROUBLESHOOTING CUTTING CONDITIONS

CONDITION	CAUSE	CURE
<p>STRINGERS - OCCASIONAL BLADES OF UNCUT GRASS</p> 	Low engine RPM	Run engine at full RPM
	Ground speed too fast	Slow speed to adjust for conditions
	Wet grass	Cut grass after it has dried out
	Dull blades, incorrect sharpening	Sharpen blades
	Deck plugged, grass accumulation	Clean underside of deck
	Belts slipping	Adjust belt tension
<p>STREAKING - STRIPS OF UNCUT GRASS IN CUTTING PATH</p> 	Dull, worn blades	Sharpen blades
	Incorrect blade sharpening	Sharpen blades
	Low engine RPM	Run engine at full RPM
	Belt slipping	Adjust belt tension
	Deck plugged, grass accumulation	Clean underside of deck
	Ground speed too fast	Slow speed to adjust for conditions
	Wet grass	Cut grass after it has dried out
	Bent blades	Replace blades
<p>STREAKING - STRIPS OF UNCUT GRASS BETWEEN CUTTING PATHS</p> 	Not enough overlapping between rows	Increase the overlap of each pass

TROUBLESHOOTING CUTTING CONDITIONS (CONT'D)

CONDITION	CAUSE	CURE
<p>UNEVEN CUT ON FLAT GROUND - WAVY HIGH-LOW APPEARANCE, SCALLOPED CUT, OR ROUGH CONTOUR</p>  <p style="text-align: right; font-size: small;">SGB020</p>	Lift worn from blade	Replace blade
	Blade upside down	Mount with cutting edge toward ground
	Deck plugged, grass accumulation	Clean underside of deck
	Too much blade angle (deck pitch)	Adjust pitch and level
	Deck mounted improperly	See your authorized SCAG dealer
	Bent spindle area	See your authorized SCAG dealer
	Dull blade	Sharpen blade
<p>UNEVEN CUT ON UNEVEN GROUND-WAVY APPEARANCE, HIGH-LOW SCALLOPED CUT, OR ROUGH CONTOUR</p>  <p style="text-align: right; font-size: small;">SGB021</p>	Uneven ground	May need to reduce ground speed, raise cutting height, and/or change direction of cut
<p>SLOPING RIDGE ACROSS WIDTH OF CUTTING PATH</p>  <p style="text-align: right; font-size: small;">SGB023</p>	Tire pressures not equal	Check and adjust tire pressure
	Wheels uneven	Check and adjust tire pressure
	Deck mounted incorrectly	See your authorized SCAG dealer
	Deck not level side-to-side	Check for level and correct

TROUBLESHOOTING CUTTING CONDITIONS (CONT'D)

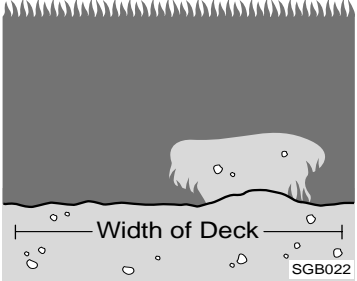
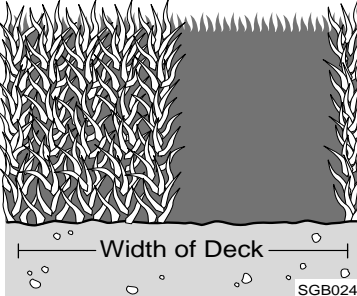
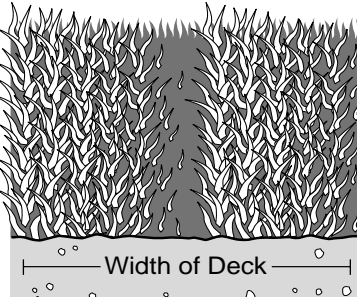
CONDITION	CAUSE	CURE
<p>SCALPING - BLADES HITTING DIRT OR CUTTING VERY CLOSE TO THE GROUND</p>  <p>Width of Deck SGB022</p>	Low tire pressures	Check and adjust pressures
	Ground speed too fast	Slow speed to adjust for conditions
	Cutting too low	May need to reduce ground speed, raise cutting height, change direction of cut, and/or change pitch and level
	Rough terrain	May need to reduce ground speed, raise cutting height, and/or change direction of cut
	Ground speed too fast	Slow speed to adjust for conditions
	Wet grass	Cut grass after it has dried out
<p>STEP CUT - RIDGE IN CENTER OF CUTTING PATH</p>  <p>Width of Deck SGB024</p>	Blades not mounted evenly	Adjust pitch and level
	Bent blade	Replace blade
	Internal spindle failure	See your authorized SCAG dealer
	Mounting of spindle incorrect	See your authorized SCAG dealer
<p>SLOPE CUT - SLOPING RIDGES ACROSS WIDTH OF CUTTING PATH</p>  <p>Width of Deck SGB025</p>	Bent spindle mounting area	See your authorized SCAG dealer
	Internal spindle failure	See your authorized SCAG dealer
	Bent deck housing	See your authorized SCAG dealer

ADJUSTMENTS

6.1 PARKING BRAKE ADJUSTMENT

⚠ WARNING

DO NOT operate the mower if the parking brake is not operable. Possible severe injury could result.

The parking brake linkage should be adjusted whenever the parking brake lever is placed in the "ENGAGE" position and the parking brake will allow the mower to move. If the following procedures do not allow you to engage the parking brake properly, contact your Scag dealer for further brake adjustments.

1. Park the machine on a flat, level surface. Block the wheels to prevent the machine from moving.

⚠ CAUTION

Adjust the brake only enough to hold the machine. Excessive force may cause damage to the machine or brake components.

2. Release the parking brake lever.
3. Look for a gap (approximately 1/4") between the right side drive tire and the brake bellcrank. See Figure 6-1. Loosen the jam nuts and adjust the brake linkage rod until there is a 1/4" gap between the tire and right hand brake bellcrank. The right hand side must be adjusted first before adjusting the brake weldment on the left side.
4. With the brake released, loosen the mounting bolt securing the left hand brake weldment to the brake bellcrank. Adjust the left hand brake weldment until there is a 1/4" gap between the tire and the brake weldment

- NOTE -

If this procedure does not achieve proper brake adjustment, please contact your authorized Scag dealer.

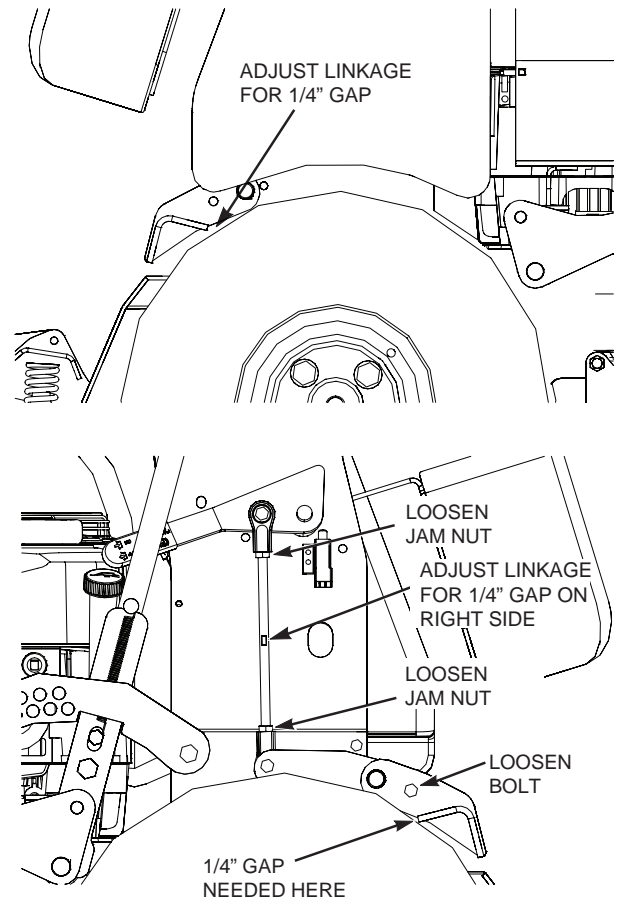

Figure 6-1. Brake Adjustment

6.2 TRAVEL ADJUSTMENT

Neutral or tracking adjustments will need to be made if:

1. The steering control is in the neutral position and the machine creeps forward or backward. (Neutral Adjustment)
2. The steering control is in the full forward position and the mower pulls to one side or the other when traveling in a forward position. (Tracking Adjustment).

NEUTRAL ADJUSTMENT

-NOTE-

Neutral has been set by your Scag dealer at the time of set up and normally does not need to be adjusted. If, however, you find that the neutral has come out of adjustment, follow the procedure below.

1. Be sure the dump valves are in the run position and the speed control lever is in the neutral lock position.
2. With an operator in the operating position, park the machine on a flat level surface, start the engine and disengage the parking brake.
3. Run the engine at full operating speed and check if the machine creeps forward or backwards.
4. Adjust the RH wheel by loosening the jam nuts on the steering control rod and turning the rod until the drive wheel turns in the forward direction. Turn the rod back until the drive wheel stops moving. Turn the rod an additional 1/2 turn. See Figure 6-2.

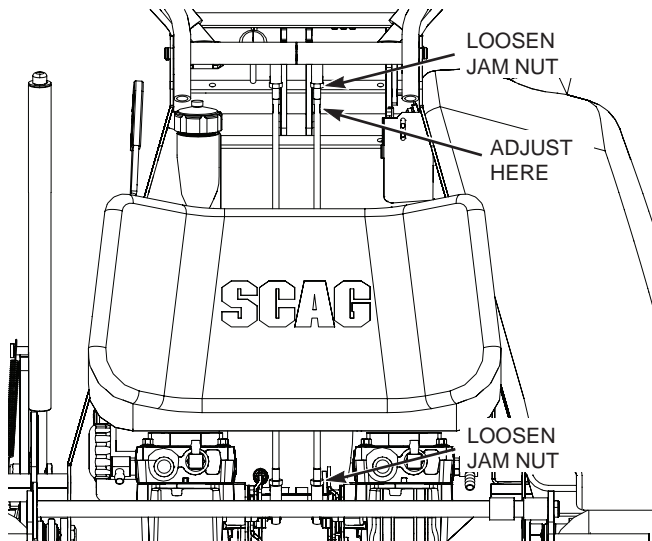

Figure 6-2. Tracking Adjustment Right Side

5. Repeat for the LH wheel. See Figure 6-3.

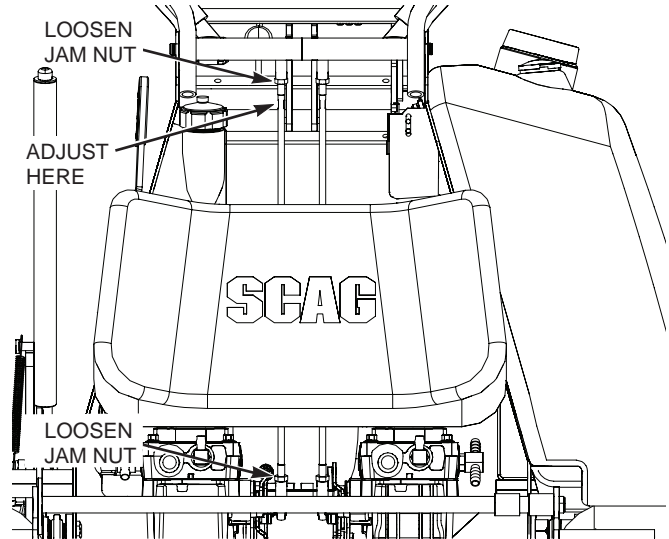

Figure 6-3.

6. Actuate the steering control levers forward and reverse several times and return them to the neutral position.
7. Check that the drive wheels remained in neutral and readjust if necessary.
8. Check that the steering control levers hit the stop before the pumps reach full stroke. Adjust as needed.

TRACKING ADJUSTMENT

⚠ CAUTION

Stop the engine and remove the key from the ignition before making any adjustments. Wait for all moving parts to come to a complete stop before beginning work.

⚠ CAUTION

The engine and drive unit can get hot during operation causing burn injuries. Allow the engine and drive components to cool before making any adjustments.

-NOTE-

Before proceeding with this adjustment, be sure that the caster wheels turn freely and that the tire pressure in the drive wheels is correct. If the tire pressure is not correct, the machine will pull to the side with the lower pressure.

1. If at full speed the mower pulls right, it is an indication that the left wheel is turning faster than the right wheel. To adjust this condition, proceed as follows:

A. Stop the machine and place the steering control levers in the neutral position. Loosen the lock nuts securing the ball joints at each end of the LH steering control rod. Rotate the control rod to lengthen the rod and tighten the lock nuts. This will cause the control rod to stroke the LH pump less, slowing down the LH wheel. See Figure 6-3.

- NOTE -

If after making the adjustment as outlined in step 1A, the machine creeps forward or backward, the neutral adjustment must be made as described on page 20.

2. If at full speed the mower pulls left, it is an indication that the right wheel is turning faster than the left wheel. To adjust this condition, proceed as follows:

A. Stop the machine and place the steering control levers in the neutral position. Loosen the lock nuts securing the ball joints at each end of the RH steering control rod. Rotate the control rod to lengthen the rod and tighten the lock nuts. This will cause the control rod to stroke the RH pump less, slowing down the RH wheel. See Figure 6-2.

- NOTE -

If after making the adjustment as outlined in step 2A, the machine creeps forward or backward, the neutral adjustment must be made as described on page 20.

6.3 THROTTLE CONTROL AND CHOKE ADJUSTMENTS

These adjustments must be performed by your Scag dealer to ensure proper and efficient running of the engine. Should either need adjustment, contact your authorized Scag service center.

6.4 BELT ADJUSTMENTS
 **WARNING**

Before removing any guards, shut the engine off and remove the ignition key. Wait for all moving parts to come to a complete stop before beginning work.

All drive belts and cutter deck belts are spring loaded and self-tensioning. The belts should be checked periodically for proper alignment and wear.

6.5 BELT ALIGNMENT

Belt alignment is important for proper performance of your Scag mower. If you experience frequent belt wear or breakage, see your authorized Scag service center for belt adjustment.

6.6 CUTTER DECK ADJUSTMENTS

Cutter deck level, pitch and height are set at the factory. However, if these adjustments should ever need to be made, the following procedures will aid in obtaining the proper cutter deck adjustment.

- NOTE -

Before proceeding with the cutter deck adjustments, be sure all tires are properly inflated.

CUTTER DECK LEVEL

The cutter deck should be level from side-to-side for proper cutting performance. To check for level, be sure that the mower is on a flat, level surface, the tires are properly inflated and the cutter deck is set at the most common cutting height that you will use. On the LH side of the machine, check the distance from the top of the cutter deck to the floor. Next check the distance from the top of the cutter deck to the floor on the RH side of the machine. Both measurements should be the same. If the two measurements are different, the cutter deck level must be adjusted as follows:

1. On the front RH side of the cutter deck locate the cutter deck adjustment levers. Loosen the elastic stop nuts securing the cutter deck adjustment levers on the front and rear of the cutter deck. See Figure 6-4.

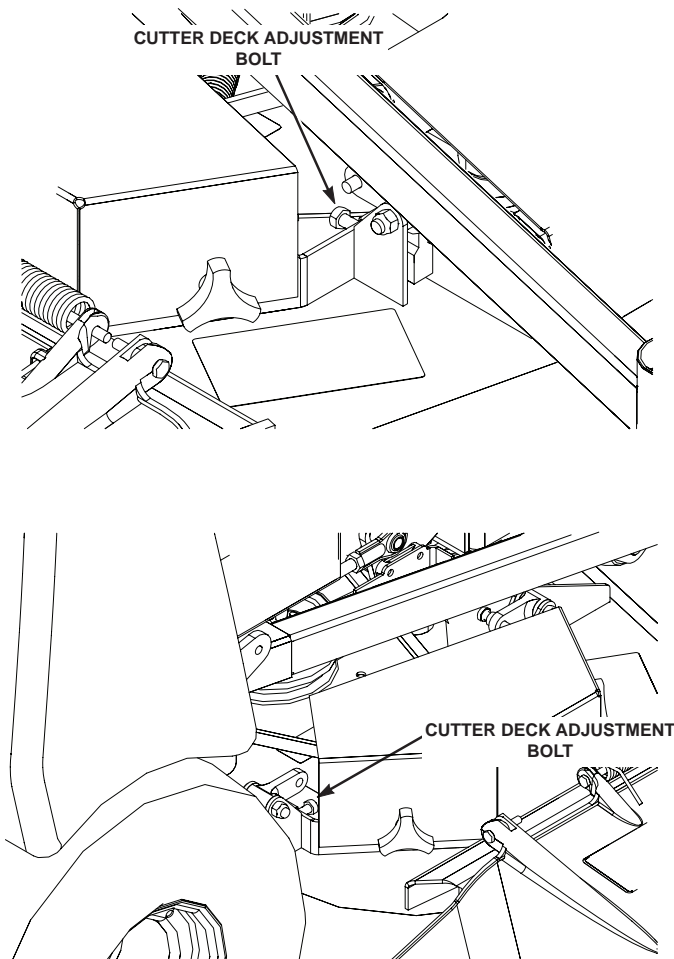

Figure 6-4. Cutter Deck Level Adjustment

2. Turn the adjustment bolts on the front and rear cutter deck adjustment levers clockwise to raise or counter-clockwise to lower the RH side until the distance from the top of the cutter deck to the floor is the same as the measurement on the LH side of the machine.
3. Tighten the two elastic stop nuts to secure the cutter deck in the proper position.

CUTTER DECK PITCH

The pitch of the cutter deck should be equal between the front and rear of the cutter deck for proper cutting performance. To check for proper deck pitch, be sure that the mower is on a flat, level surface and the tires are properly inflated.

Check the distance from the top of the cutter deck to the floor at the rear RH side of the cutter deck. Next check the distance from the top of the cutter deck to the floor at the front RH side of the cutter deck. The measurement at the front of the cutter deck should be the same as the rear of the deck. Make these measurements at the LH side of the cutter deck also. If the measurement at the front of the deck is not the same, the cutter deck pitch must be adjusted as follows:

1. Loosen the elastic stop nuts securing the deck level links on front of the cutter deck on both sides See Figure 6-5.
2. Turn the adjustment bolts on both side either clockwise to raise or counterclockwise to lower the front of the cutter deck until the measurements are equal. Tighten the elastic stop nuts.

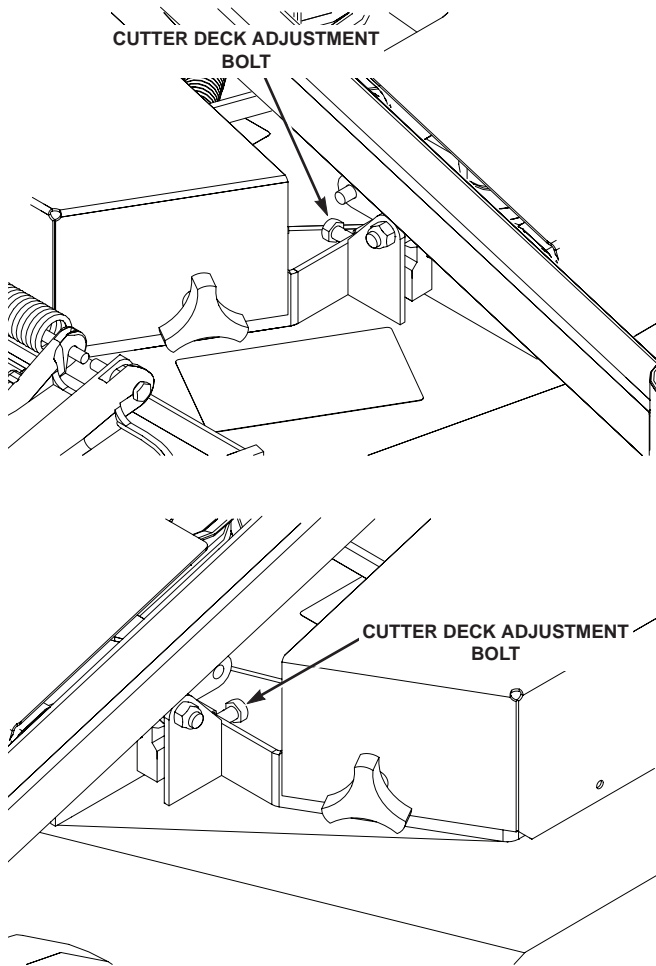

Figure 6-5. Cutter Deck Pitch Adjustment

CUTTER DECK HEIGHT

The cutter deck height adjustment is made to ensure that the cutter deck is cutting at the height indicated on the cutting height index gauge. To check for proper deck height, be sure that the mower is on a flat, level surface, shut off the engine and remove the ignition key. Make sure the tires are properly inflated.

1. Check the cutter deck cutting height by placing the lanyard pin in the 3" position on the cutting height index. Release the deck from the transport position and allow the deck to move to the 3" cutting height position.

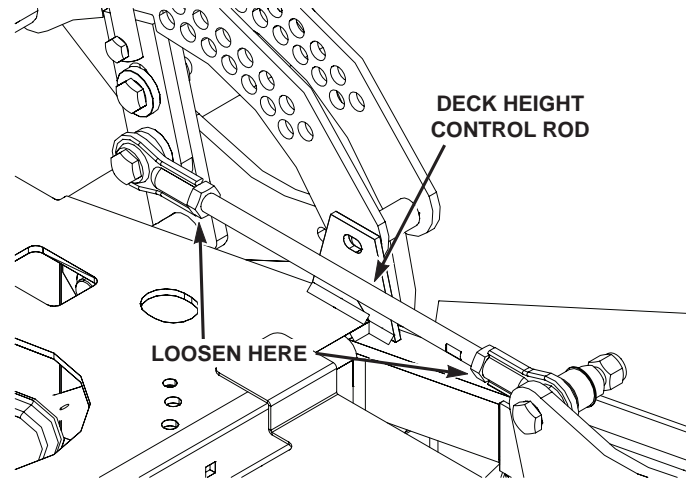

Figure 6-6. Cutter Deck Height Adjustment

2. Rotate the cutter blade on the left side of the cutter deck. Position the cutter blade so it is facing "front to back" on the machine.

! WARNING

Always wear proper hand and eye protection when working with cutter blades.

3. Check the measurement from the floor to the cutter blade tip at the rear of the left side blade. If the measurement is not at 3", an adjustment can be made using the deck height control rod.
4. Adjust by loosening the jam nuts on the deck height control rod. Turn the deck height control rod until the 3" setting is achieved. Hold the deck height control rod and tighten the jam nuts. See Figure 6-6.
5. Once the adjustment is made to the deck height control rod, Check the measurement from the floor to the cutter blade tip at the front of the left side blade. If the measurement is not at 3", an adjustment must be made using the cutter deck adjustment lever. Adjust as follows:

A. Loosen the elastic stop nuts securing the deck level links on front of the cutter deck on both sides (See Figure 6-4 and Figure 6-5 for Cutter Deck Adjustment Lever Location).

B. Turn the adjustment bolts on both side either clockwise to raise or counterclockwise to lower the front of the cutter deck until the measurements are equal. Tighten the elastic stop nuts.

6. Rotate the cutter blade on the right side of the cutter deck. Position the cutter blade so it is facing "front to back" on the machine.
7. Check the measurement from the floor to the cutter blade tip at the front and rear of the right side blade. If the measurement is not at 3", an adjustment must be made using the cutter deck adjustment lever. Adjust as follows:

A. Loosen the elastic stop nuts securing the deck level links on front of the cutter deck on both sides (See Figure 6-4 and Figure 6-5 for Cutter Deck Adjustment Lever Location).

B. Turn the adjustment bolts on both side either clockwise to raise or counterclockwise to lower the cutter deck until the measurements are equal. Tighten the elastic stop nuts.

CUSTOM-CUT BAFFLE ADJUSTMENT

The Custom-Cut Baffle is designed to deliver optimum airflow and superior cutting performance in any type of grass. The Custom-Cut Baffle can be raised or lowered to precisely tailor the deck's performance for the type of grass being cut. The baffle can be set in seven (7) different positions for optimum performance.

- A. 3-1/2" or 3-3/4" Position - See Figure 6-7. For very tall, wiry or tough-to-cut grass.
- B. 4" (factory setting), 4-1/4" or 4-1/2" Position - See Figure 6-7. For general purpose cutting. This gives the best mix of cutting performance in all types of grass.
- C. 4-3/4" or 5-1/4" Position - See Figure 6-7. Placing the baffle in either the 4-3/4" or 5-1/4" setting will enhance fall cutting (leaf pickup) and reduce cutter deck "blowout".

To adjust the Custom-Cut Baffle height:

1. Park the machine on a flat surface, apply the parking brake, shut off the engine and remove the key.
2. Place the cutter deck in the transport position.
3. Remove the hardware securing the Custom-Cut Baffle to the cutter deck.

- NOTE -

Hardware location used in the illustrations are for reference only. Location of hardware may vary depending on cutter deck size.

4. Move the Custom-Cut Baffle to desired position. See Figures 6-7.
5. Reinstall the mounting hardware. Torque hardware to 39 ft-lbs.

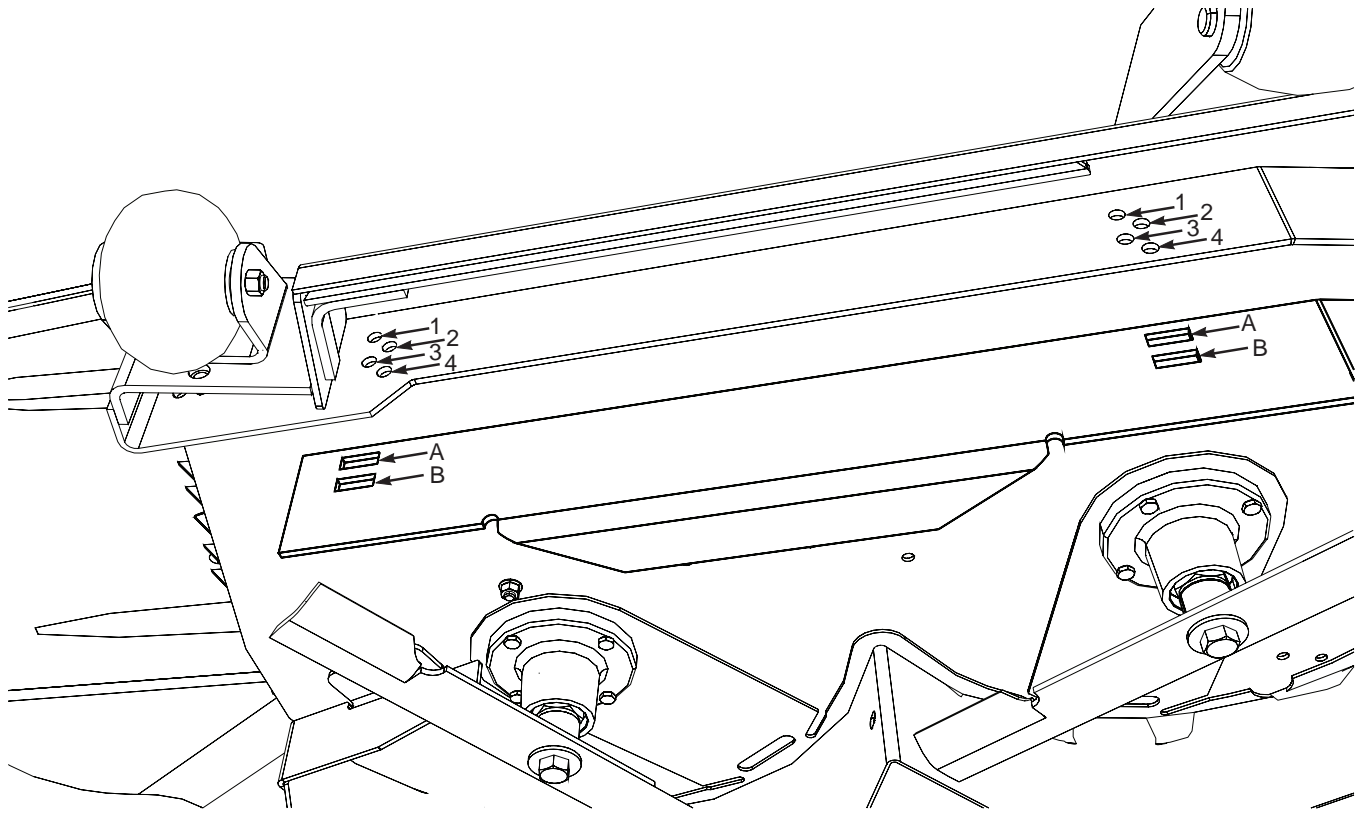

Custom-Cut Baffle Adjustment

Mounting Slot Selected	Mounting Hardware Location			
	Hole 1	Hole 2	Hole 3	Hole 4
Slot "A"				
Height (inches)	3-3/4"	4-1/4"	4-3/4"	5-1/4"
Slot "B"				
		Hole 2	Hole 3	Hole 4

Figure 6-7. Custom-Cut Baffle Adjustment

6.7 ELECTRIC CLUTCH ADJUSTMENT

The electric clutch serves two functions in the operation of the mower. In addition to starting and stopping the power flow to the cutter blades, the clutch also acts as a brake to assist in stopping blade rotation when the PTO is switched off or the operator presence circuit is interrupted.

When the clutch is disengaged, the air gap between the armature and rotor must be adjusted to fifteen thousandths of an inch, 0.015, for proper operation. The airgap adjustment is made at three bolts on the clutch. There are three inspection windows, one next to each adjusting bolt. See Figure 6-8.

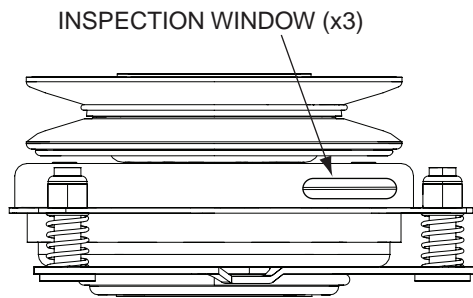

Figure 6-8. Clutch Air Gap Adjustment

1. Locate the inspection windows on the clutch.
2. Place a 0.015 feeler gauge in the slot between the rotor and the armature. See Figure 6-9.

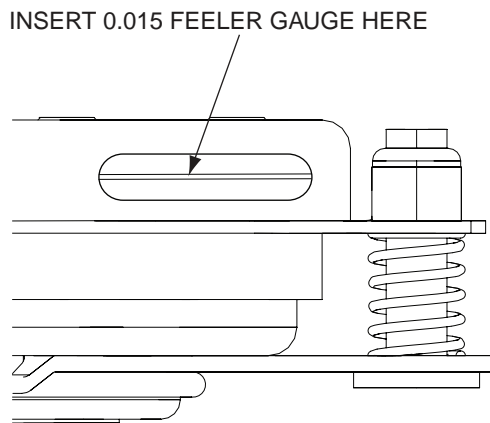

Figure 6-9. Clutch Air Gap Adjustment

3. Tighten or loosen the adjusting bolt as needed to achieve the 0.015 inch airgap. See Figure 6-10. Perform this operation at all three inspection windows.

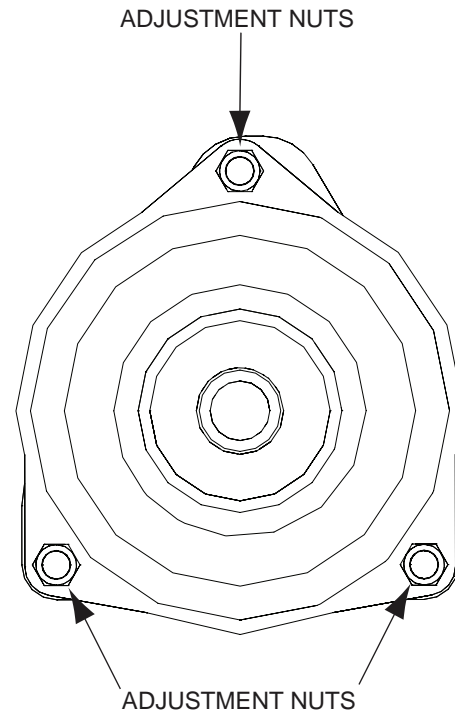

Figure 6-10. Clutch Air Gap Adjustment

This adjustment should be done every 500 hours of operation or annually, whichever comes first. In cases where the machine is heavily used, airgap settings should be checked more often.

If the air gap is too narrow, the clutch armature may drag when disengaged, resulting in premature failure.

If the air gap is too wide, the clutch may be slow to engage as the magnet must pull the armature in from a greater distance.

6.8 FRONT WEIGHT ADJUSTMENT

This mower has been designed for good traction and stability under normal mowing conditions. However, caution must be used when traveling on slopes, especially when the grass is wet. Wet grass reduces traction and steering control.

The 36" model comes standard with two (2) weights installed and the 48" and 52" models come standard with one (1) weight installed. All models must not be operated with less than the number of weights listed above.

Section 6

Additional weight can be added to the front of the machine if needed. See Figure 6-11.

1. Remove the front belt from the machine.
2. Remove the mounting hardware securing the weight(s) to the front of the machine.
3. Add the desired weight to the machine and secure using the recommended hardware. See Figure 6-11.
4. Reinstall the front belt cover.

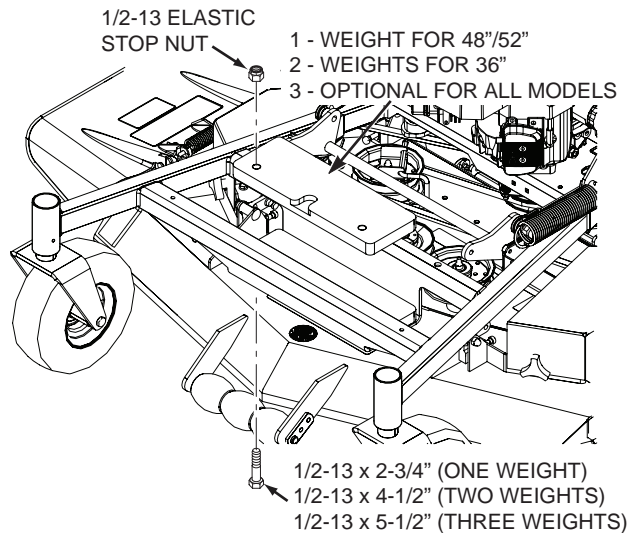

Figure 6-11. Front Weight Adjustment

6.9 OPERATOR CUSHION ADJUSTMENT

The operator cushion can be mounted in twelve (12) different positions to fit a wide range of operators. See Figure 6-12.

1. Remove the hardware securing the operator cushion to the mounting bracket and set the cushion aside.
2. Remove the hardware securing the mounting bracket.
3. Install and secure the mounting bracket in the desired operating location. Locations A, B or C for lower mounting positions or rotate the mounting bracket 180 degree and install in G for higher mounting positions. See Figure 6-12.
4. Install and secure the operator cushion in the desired location. Locations D, E or F for the lower mounting positions or H, I or J for the higher mounting positions. See Figure 6-12.

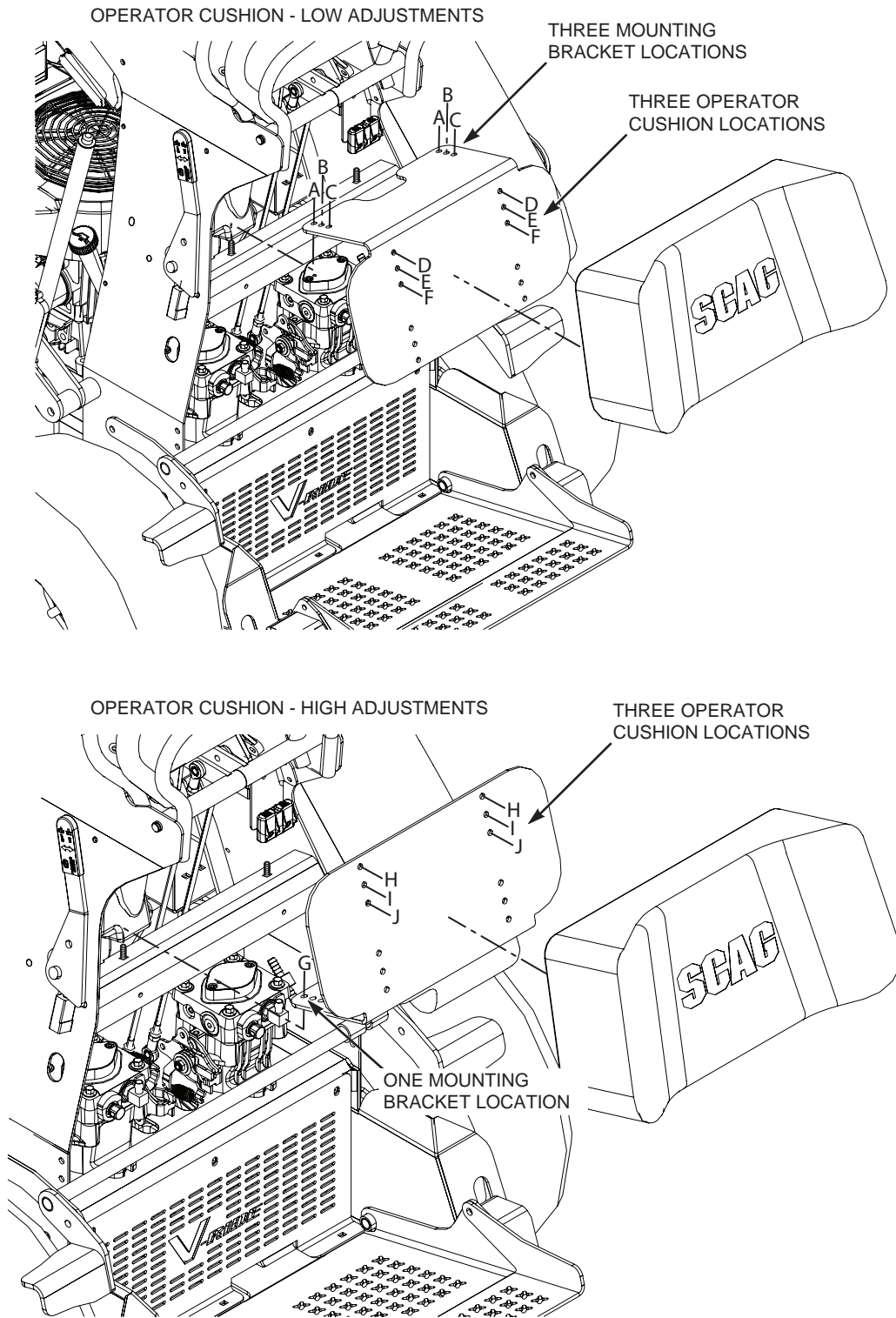

Figure 6-12. Operator Cushion Adjustment

MAINTENANCE

7.1 MAINTENANCE CHART - RECOMMENDED SERVICE INTERVALS

BREAK-IN (FIRST 10)	HOURS						PROCEDURE	COMMENTS
	8	20	40	100	200	500		
X							Check all hardware for tightness	
X							Check hydraulic oil level	See paragraph 7.3
X							Check belts for proper alignment	See paragraph 6.5
X							Check hydraulic hoses for leaks	Use extreme caution when checking the hydraulic hoses. See paragraph 2.5
	X						Check engine oil level	See paragraph 7.4
	X						*Clean mower	
	X						Check tire pressure	See paragraph 7.9
	X						*Clean air filter element	See paragraph 7.6
	X						Check condition of blades	See paragraph 7.8
	X						Apply grease to fittings	See paragraph 7.2
	X						Check safety interlock system	See paragraph 4.2
		X					Change engine oil and filter	See paragraph 7.4
			X				Check belts for proper alignment	See paragraph 6.5
				X			Check belts for proper alignment	See paragraph 6.5
				X			*Clean engine air filter	See engine operator's manual
				X			Apply grease to fittings	See paragraph 7.2
				X			Check all hardware for tightness	
				X			Change engine oil	See paragraph 7.4
				X			*Clean air cleaner element	See paragraph 7.6

* Perform these maintenance procedures more frequently under extreme dusty or dirty conditions

MAINTENANCE CHART - RECOMMENDED SERVICE INTERVALS (CONT'D)

BREAK-IN (FIRST 10)	HOURS					PROCEDURE	COMMENTS
	8	40	100	200	500		
				X		Check hardware for tightness	
				X		Apply grease to fittings	See paragraph 7.2
				X		Check hydraulic oil level	See paragraph 7.3
				X		Change engine oil	See paragraph 7.4
				X		Change engine oil filter	See paragraph 7.4
					X	Replace engine fuel filter	See paragraph 7.5
					X	Apply grease to fittings	See paragraph 7.2
					X	Drain hydraulic system and replace oil and filter	See paragraph 7.3
					X	Adjust electric PTO clutch	See paragraph 6.6

7.2 LUBRICATION

GREASE FITTING LUBRICATION CHART

LOCATION	LUBRICATION INTERVAL	LUBRICANT	NO. OF PLACES
1 - Caster Wheel Pivot	100 Hours / Bi-Weekly	Chassis Grease	2
2 - Caster Wheel Bearings	100 Hours / Monthly	Chassis Grease	2
3 - Brake Actuator Lever	200 Hours / Bi-Weekly	Chassis Grease	1
4 - Cutter Deck Spindles	40 Hours / Weekly	+ US Lithium MP White Grease	2 / 3
5 - Cutter Deck Pusharms	100 Hours / Monthly	Chassis Grease	2
6 - Cutter Deck Bellcranks	100 Hours / Monthly	Chassis Grease	2

GREASE FITTING LUBRICATION

Lubricant Interval

□ Lithium MP White Grease 2125
(40 Hours/Weekly)

○ Chassis Grease
(100 Hours/Bi-weekly)

⬡ Chassis Grease
(200 Hours/Monthly)

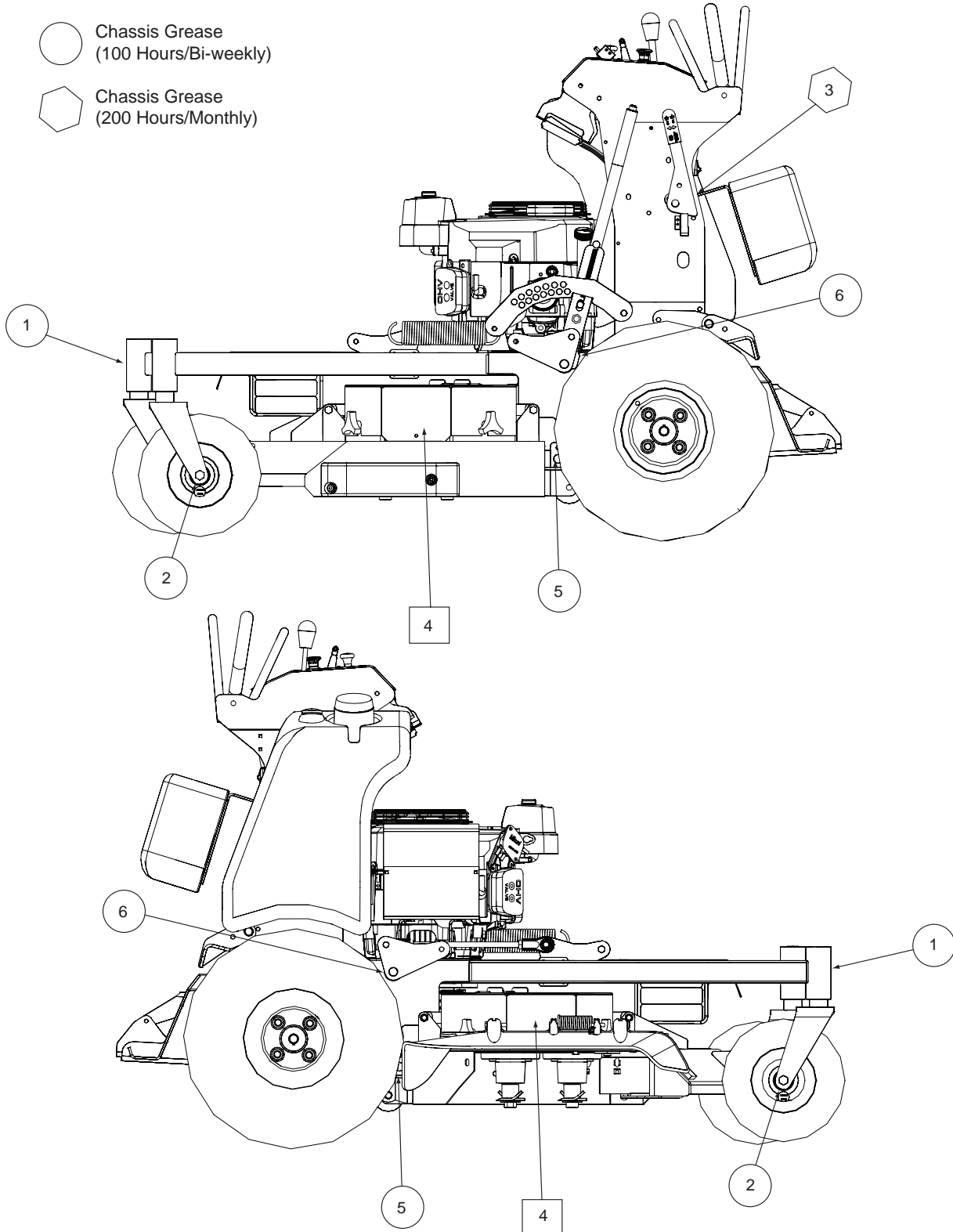

Figure 7-1. Lubrication Fitting Points

7.3 HYDRAULIC SYSTEM

A. CHECKING HYDRAULIC OIL LEVEL

The hydraulic oil level should be checked after the first 8 hours of operation. Thereafter, check the oil after every 200 hours of machine operation or monthly, whichever occurs first.

- IMPORTANT -

If the oil level is consistently low, check for leaks and correct immediately.

1. Wipe dirt and contaminants from around the reservoir cap. Remove the cap from the hydraulic oil reservoir.
2. Visually check the level of hydraulic oil. Hydraulic oil must be at least 2-1/4" inches from top of the filler neck. If the level cannot be determined visually, use a clean tape measure to check the level. If the fluid is low, add 20W50 motor oil. DO NOT overfill; (overfilling the oil reservoir may cause oil seepage around the cap area).
3. Clean the fill cap and install it onto the reservoir.

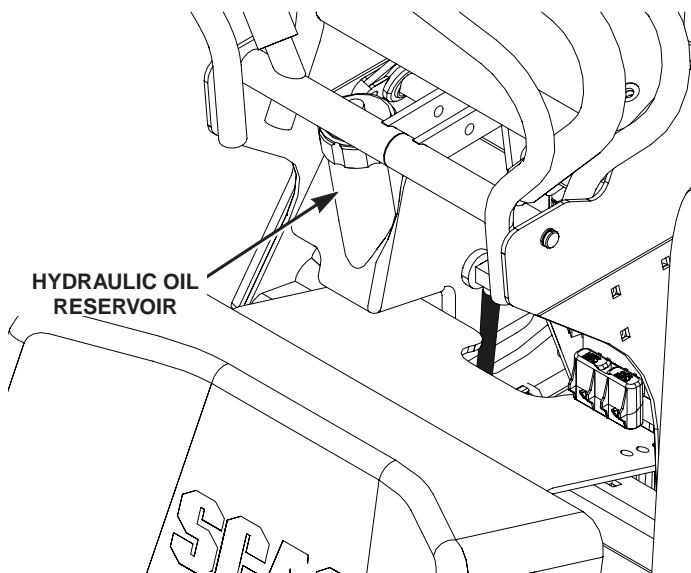

Figure 7-2. Hydraulic Oil Reservoir

B. CHANGING HYDRAULIC OIL

The hydraulic oil should be changed after every 500 hours or annually, whichever occurs first. The oil should also be changed if the color of the fluid has become black or milky. A black color and/or a rancid odor usually indicates possible overheating of the oil, and a milky color usually indicates water in the hydraulic oil.

- IMPORTANT -

The hydraulic oil should be changed if you notice the presence of water or a rancid odor to the hydraulic oil.

1. Park the mower on a level surface, stop the engine and remove the ignition key.
2. Place a suitable container under the hydraulic oil filter. Remove the fill cap from the reservoir. Remove the drain plug from the fitting on the filter base. See Figure 7-3. Allow the fluid to drain into the container and properly discard it.
3. Re-install the drain plug into the tee fitting and be sure it is tight.

- NOTE -

Before refilling the hydraulic oil reservoir the hydraulic oil filter should be changed as outlined in Procedure C "Changing Hydraulic Oil Filter Element".

4. Fill the reservoir to full 2-1/4" inches below the filler neck with 20W50 motor oil.
5. Replace the reservoir fill cap. Start the engine and drive forward and backward for two minutes. Check the oil level in the reservoir. If necessary, add oil to the reservoir.

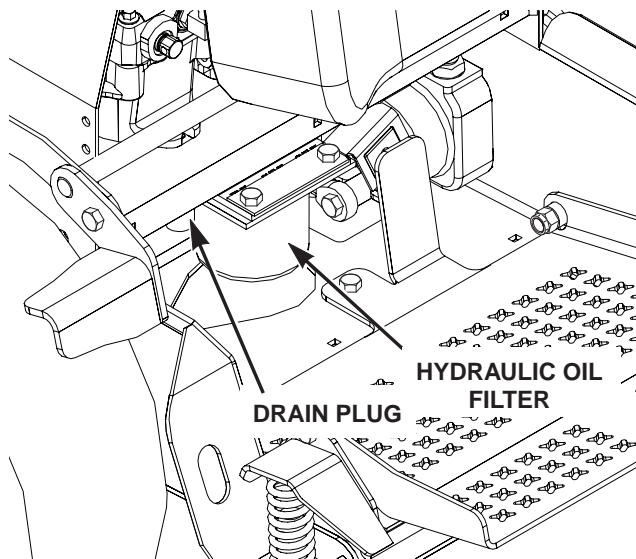

Figure 7-3. Hydraulic Oil Filter

C. CHANGING HYDRAULIC OIL FILTER ELEMENT

The hydraulic oil filter should be changed after every 500 hours of operation or annually, whichever occurs first.

1. Remove the oil filter element. See Figure 7-3. Properly discard the oil filter element. Fill the new filter with clean oil and install the filter. Hand tighten only.
2. Run the engine at idle speed with the speed control lever in neutral for five minutes.
3. Check the oil level in the hydraulic tank. Hydraulic oil must be at the full tab below the filler neck. If necessary, add SAE 20w50 motor oil.

7.4 ENGINE OIL

A. CHECKING ENGINE CRANKCASE OIL LEVEL

The engine oil level should be checked after every 8 hours of operation or daily as instructed in the Engine Operator's Manual furnished with this mower.

B. CHANGING ENGINE CRANKCASE OIL

After the first 20 hours of operation, change the engine crankcase oil and replace the oil filter. Thereafter, change the engine crankcase oil after every 100 hours of operation or monthly, whichever occurs first. Refer to the Engine Operator's Manual furnished with this mower for instructions.

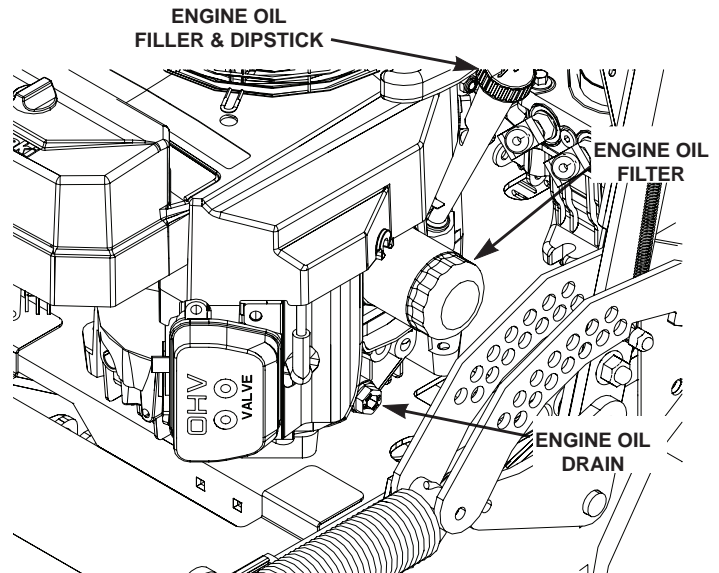

Figure 7-4. Drain Plug, Dipstick and Oil Filter Location

C. CHANGING ENGINE OIL FILTER

After the first 20 hours of operation, replace the engine oil filter. Thereafter, replace the oil filter after every 200 hours of operation or every month, whichever occurs first. Refer to Engine Operator's Manual for instructions.

! DANGER

To avoid injury from burns, allow the mower to cool before changing the oil and removing the filter.

7.5 ENGINE FUEL SYSTEM

DANGER

To avoid injury from burns, allow the mower to cool before removing the fuel tank cap and refueling.

A. FILLING THE FUEL TANK

Fill the fuel tank at the beginning of each operating day to within one (1) inch below the bottom of the filler neck. Do not overfill. Use clean, fresh unleaded gasoline with a minimum octane rating of 87 and a maximum of 10% Ethanol.

DO NOT use E85 Fuel. Using E85 Fuel will cause severe damage to the engine.

To avoid personal injury or property damage, use extreme care in handling gasoline. Gasoline is extremely flammable and the vapors are explosive.

1. Extinguish all cigarettes, cigars, pipes and other sources of ignition.
2. Use only an approved gasoline container.
3. Never remove the gas cap or add fuel with the engine running. Allow the engine to completely cool before fueling.
4. Never fuel the machine indoors or in an enclosed trailer.
5. Never store the machine or fuel container where there is an open flame, spark or pilot light such as on a water heater or other appliances.
6. Never fill containers inside a vehicle or on a truck or trailer bed with a plastic liner. Always place containers on the ground away from your vehicle before filling.
7. Remove the machine from the truck or trailer and fuel on the ground. If this is not possible, then refuel the machine with a portable container, rather than from a gasoline dispenser nozzle.
8. Keep the nozzle in contact with the rim of fuel tank or container opening at all times until fueling is complete. Do not use a nozzle lock-open device.

9. If fuel is spilled on clothing, change clothing immediately and wash affected skin.
10. Replace gas cap and tighten securely.

B. REPLACING IN-LINE FUEL FILTER ELEMENTS

The engine fuel filter should be replaced after every 500 hours of operation or annually, whichever occurs first. See Figure 7-5.

1. Close the shutoff valve. Remove the two clamps securing the fuel filter to the fuel hose. Remove the fuel filter.
2. Install a new fuel filter. Be sure it is installed in the proper direction. Secure to the fuel hose using the two clamps.

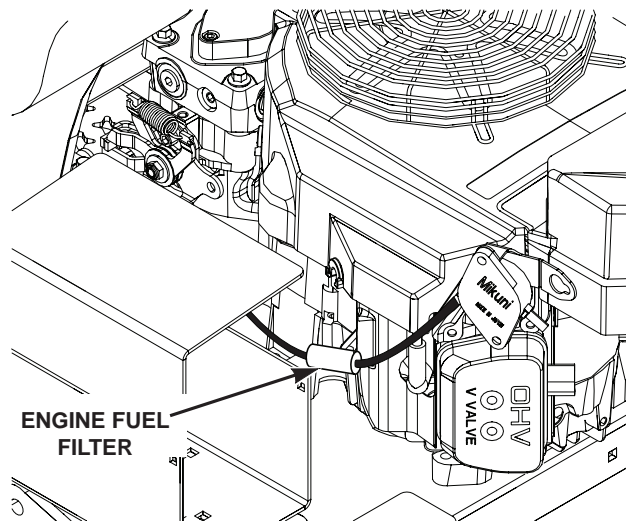

Figure 7-5. Fuel Filter

7.6 ENGINE AIR CLEANER

A. CLEANING AND/OR REPLACING AIR CLEANER ELEMENT

For any air cleaner, the operating environment dictates the air cleaner service periods. Inspect and clean the air cleaner element after every 100 hours of operation or monthly, whichever occurs first and replace the element if required. See Engine Owner's Manual for service information.

Section 7

- NOTE -

In extremely dusty conditions it may be necessary to check the element once or twice daily to prevent engine damage.

1. Snap open the two clips securing the air cleaner cover to the air cleaner box. Remove the air cleaner cover, clean the duck bill vent of any dust or debris and set the cover aside.
2. Remove the air cleaner and inspect.
3. Clean or replace the air cleaner as recommended by the engine manufacturer. Replace the air cleaner cover and secure.
4. Replace the air filter cover and be sure to snap the two clips closed.

7.7 BATTERY - ELECTRIC START MODELS

WARNING

Lead-acid batteries produce flammable and explosive gases. To avoid personal injury when checking, testing or charging batteries, **DO NOT** use smoking materials near batteries. Keep arcs, sparks and flames away from batteries. Provide proper ventilation and wear safety glasses.

WARNING

Battery posts, terminals, and related accessories contain lead and lead compounds, chemicals known to cause cancer and reproductive harm. Wash hands after handling.

WARNING

Electric storage battery fluid contains sulfuric acid which is **POISON** and can cause **SEVERE CHEMICAL BURNS**. Avoid contact of fluid with eyes, skin, or clothing. Use proper protective gear when handling batteries. **DO NOT** tip any battery beyond 45° angle in any direction. If fluid contact does occur, follow first aid suggestions below.

BATTERY ELECTROLYTE FIRST AID

External Contact — Flush with water.

Eyes — Flush with water for at least 15 minutes and get medical attention immediately.

Internal — Drink large quantities of water. Follow with Milk Of Magnesia, beaten egg, or vegetable oil. Get medical attention immediately. In case of internal contact, DO NOT give fluids that would induce vomiting.

A. CHARGING THE BATTERY

Refer to the battery charger's manual for specific instructions.

Under normal conditions the engine's alternator will have no problem keeping a charge on the battery. If the battery has been completely discharged for a long period of time, the alternator may not be able to recharge the battery, and a battery charger will be required.

DO NOT charge a frozen battery. It may explode and cause injury. Let the battery warm before attaching a charger.

Whenever possible, remove the battery from the mower before charging and make sure the electrolyte covers the plates in all cells.

WARNING

BATTERIES PRODUCE EXPLOSIVE GASES. Charge the battery in a well ventilated space so gases produced while charging can dissipate.

Charging rates between 3 and 50 amperes are satisfactory if excessive gassing or spewing of electrolyte does not occur or the battery does not feel excessively hot (over 125°F). If spewing or gassing occurs or the temperature exceeds 125°F, the charging rate must be reduced or temporarily stopped to permit cooling.

B. JUMP STARTING

1. The booster battery must be a 12 volt type. If a vehicle is used for jump starting, it must have a negative ground system.
2. When connecting the jumper cables, connect the positive cable to the positive battery post, then connect the negative cable to the negative battery post.

7.8 CUTTER BLADES

A. BLADE INSPECTION

1. Remove the ignition key before servicing the blades.
2. Raise the mower deck to the highest position. Place the lanyard pin in the highest cutting height position to prevent the cutter deck from falling.

WARNING

Always wear proper hand and eye protection when working with cutter blades.

3. Check the cutter blades for straightness. If the cutter blades appear bent, they will need to be replaced.

WARNING

Do not attempt to straighten a bent blade, and never weld a broken or cracked blade. Always replace it with a new blade to assure safety.

4. If a blade cutting edge is dull or nicked, it should be sharpened. Remove the blades for sharpening. See "Blade Replacement."

- NOTE -

Keep the blades sharp. Cutting with dull blades not only yields a poor mowing job, but slows the cutting speed of the mower and causes extra wear on the engine and the blade drive by pulling hard.

B. BLADE SHARPENING

- NOTE -

If possible, use a file to sharpen the blade. Using a wheel grinder may burn the blade.

- NOTE -

DO NOT sharpen the blades beyond 1/3 of the width of the blade. See Figure 7-6.

1. Sharpen the cutting edge at the same bevel as the original. See Figure 7-6. Sharpen only the top of the cutting edge to maintain sharpness.

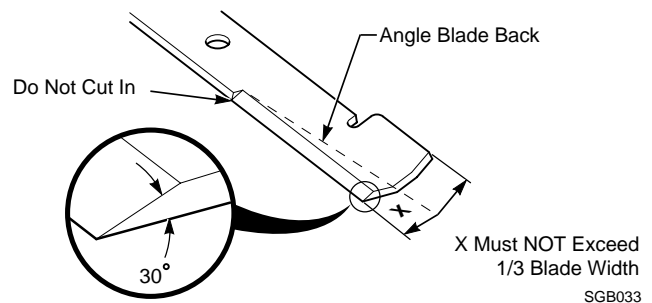

Figure 7-6. Blade Sharpening

2. Check the balance of the blade. If the blades are out of balance, vibration and premature wear can occur. See your authorized Scag dealer for blade balancing or special tools, if you choose to balance your own blades.

C. BLADE REPLACEMENT

WARNING

Always wear proper hand and eye protection when working with cutter blades.

1. Remove the ignition key before replacing the blades.

Section 7

2. Raise the mower deck to the highest position. Place the lanyard pin in the highest cutting height position to prevent the cutter deck from falling.
3. Secure the cutter blades to prevent them from rotating, (use the optional Blade Buddy tool, P/N 9212, to assist in securing the cutter blades), remove the nut from the blade attaching bolt. Remove the cutter blade, bolt and spacer from the spindle shaft. See Figure 7-7.

- NOTE -

The front of the machine will have to be raised slightly to remove the blade bolt from the cutter spindle.

4. To install the new cutter blade, put the flat washer onto the blade bolt and slide the bolt into the hole in the cutter blade.

- NOTE -

Be sure that the blade is installed with the lift wing pointing toward the top of the deck.

5. Install the spacer onto the blade bolt and insert the bolt into the cutter spindle shaft.
6. Install the hex nut to the blade bolt at the top of the cutter spindle. Secure the blades from rotating and torque to 75 ft/lbs. See Figure 7-7.

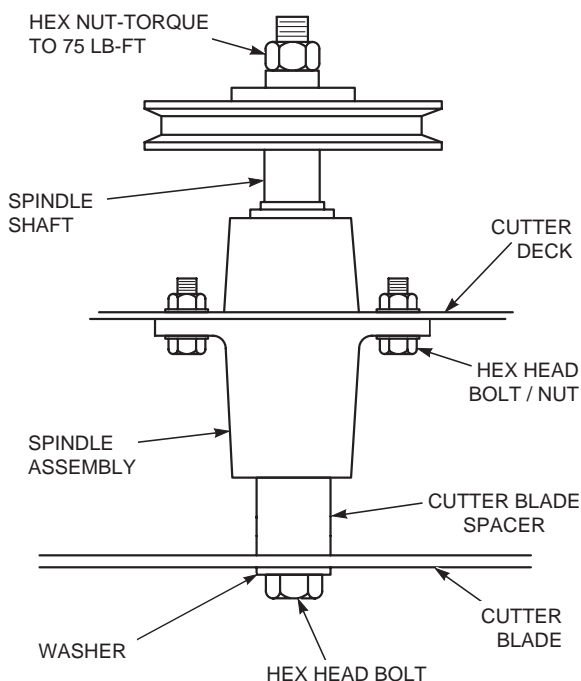

Figure 7-7. Blade Replacement

7.9 TIRES

Check the tire pressures after every 8 hours of operation or daily.

Caster Wheels	Flat-Free
Drive Wheels	12 PSI

7.10 BODY AND DECK

CAUTION

Do not wash any portion of the equipment while it is hot. Do not wash the engine; use compressed air.

1. After each use, wash the mower and cutter deck. Use cold water and automotive cleaners. Do not use pressure cleaners.
2. Do not spray electrical components.
3. Repair damaged metal surfaces using Scag touch-up paint (P/N 48521) available from your authorized Scag dealer. Wax the mower with an automotive paint wax for maximum paint protection.

ILLUSTRATED PARTS LIST

8.1 SCAG APPROVED ATTACHMENTS AND ACCESSORIES.

Attachments and accessories manufactured by companies other than Scag Power Equipment are not approved for use on this machine.

Scag approved attachments and accessories:

- Mulch Plate (p/n 9258, 9286, 9287)
- Hurricane Mulch (p/n 9263, 9283, 9284)
- GC-4D (p/n 9054)
- GC-F4 (p/n 9055)
- Blade Buddy (p/n 9212)
- Chrome Wheel Covers (p/n 920H) - Excludes SVR-36

NOTES

36A CUTTER DECK

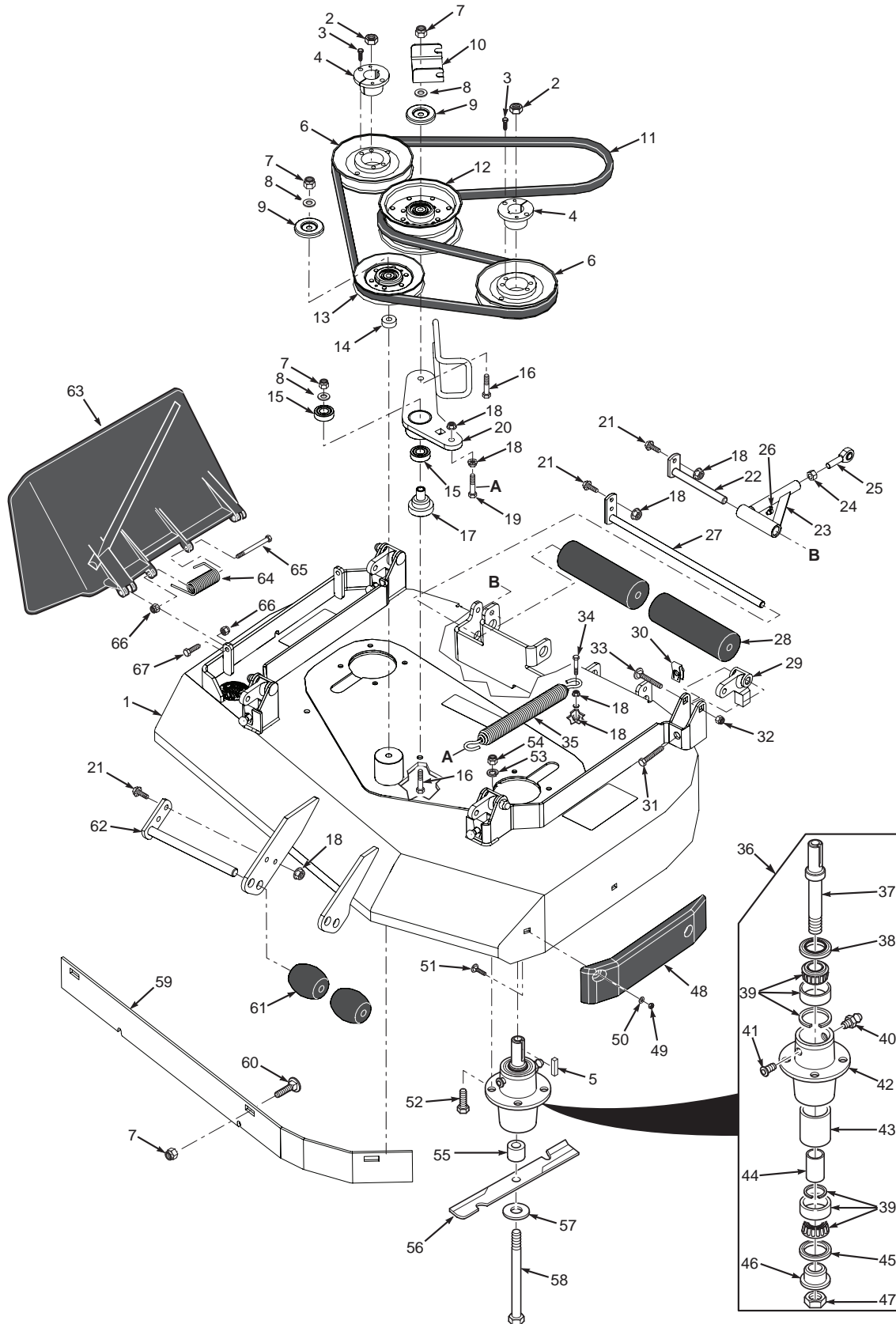

36A CUTTER DECK

Ref. No.	Part No.	Description
1	462236	Cutter Deck w/Decals
2	04020-09	Nut, 5/8-11 UNC
3	04001-172	Bolt, Hex Head 1/4-20 x 1"
4	48926	Tapered Hub, 1.125" Bore
5	04063-08	Key, 1/4 x 1/4 x 2"
6	483284	Pulley, 5.73 OD Tapered Bore
7	04021-09	Nut, Elastic Stop 3/8-16
8	04043-04	Flatwasher, 3/8-.391 x .938 x .105
9	424367	Dust Shield
10	424615	Bracket, Belt Guide
11	483969	Belt, Cutter Deck
12	483210	Pulley, 5" Idler
13	48181	Pulley, Idler
14	43077	Spacer
15	48224	Bearing
16	04001-62	Bolt, Hex Head 3/8-16 x 3-1/4"
17	43816	Pivot, Idler
18	04019-04	Nut, Serrated Flange 3/8-16
19	04001-136	Bolt, Hex Head 5/16-18 x 1-1/2" Gr.8
20	462233	Idler Arm Assy. (Incl. # 15)
21	04001-09	Bolt, Hex Head 5/16-18 x 1"
22	451724	Shaft Weldment, Pusharm Mount
23	461755	Pusharm Assy., LH
	461756	Pusharm Assy., RH
24	04020-08	Nut, 1/2-20 UNF
25	48542	Rod End, 1/2-20 RH
26	48114-08	Grease Fitting
27	452076	Shaft Weldment
28	483997	Guide Roller
29	483361	Lever, Deck Level
30	04110-03	U-Nut, 3/8-16
31	04107-04	Bolt, Hex Head 3/8-16 x 2" Special
32	04021-11	Nut, Elastic Stop 7/16-14
33	04003-42	Bolt, Carriage 7/16-14 x 2-1/4"
34	04001-136	Bolt, Hex Head 3/8-16 x 1-1/2" Gr.8
35	484020	Spring
36	461663	Spindle Assembly
37	43589	Shaft, Spindle
38	481024	Seal, Upper
39	481022	Bearing Assembly
40	48114-04	Grease Fitting
41	48677	Valve, Grease Relief
42	43644	Housing, Spindle
43	43312	Spacer, Outside
44	43296	Spacer, Inside

Ref. No.	Part No.	Description
45	481025	Seal, Lower
46	43297	Bushing, Lower
47	481035	Nut, Special 1-1/16" - 18
48	483174	Pad, Deck Wear
49	04021-04	Nut, Center Lock 5/16-18
50	04040-04	Flatwasher, 5/16-.344 x .688 x .065
51	04003-12	Bolt, Carriage 5/16-18 x 1-3/4"
52	04001-176	Bolt, Hex Head 5/16-18 x 1-3/4"
53	04030-03	Lockwasher, 5/16" Spring
54	04021-22	Nut, Elastic Stop 5/16-18
55	43590	Spacer, Spindle Bottom
56	482878	Cutter Blade, 18"
57	04043-06	Flatwasher, 5/8-.688 x 1.75 x .134 HD
58	04001-41	Bolt, Hex Head 5/8-11 x 9-1/2"
59	423783	Baffle, Flange 36A
60	04003-23	Bolt, Carriage 3/8-16 x 1"
61	482295	Wheel, Anti-Scalp
62	451926	Shaft Weldment
63	461356	Discharge Chute Assembly
64	482245	Spring, Discharge Chute
65	04001-154	Bolt, Hex Head 5/16-18 x 4-3/4"
66	04021-10	Nut, Elastic Stop 5/16-18
67	04001-12	Bolt, Hex Head 5/16-18 x 1-3/4"

48V & 52V CUTTER DECKS

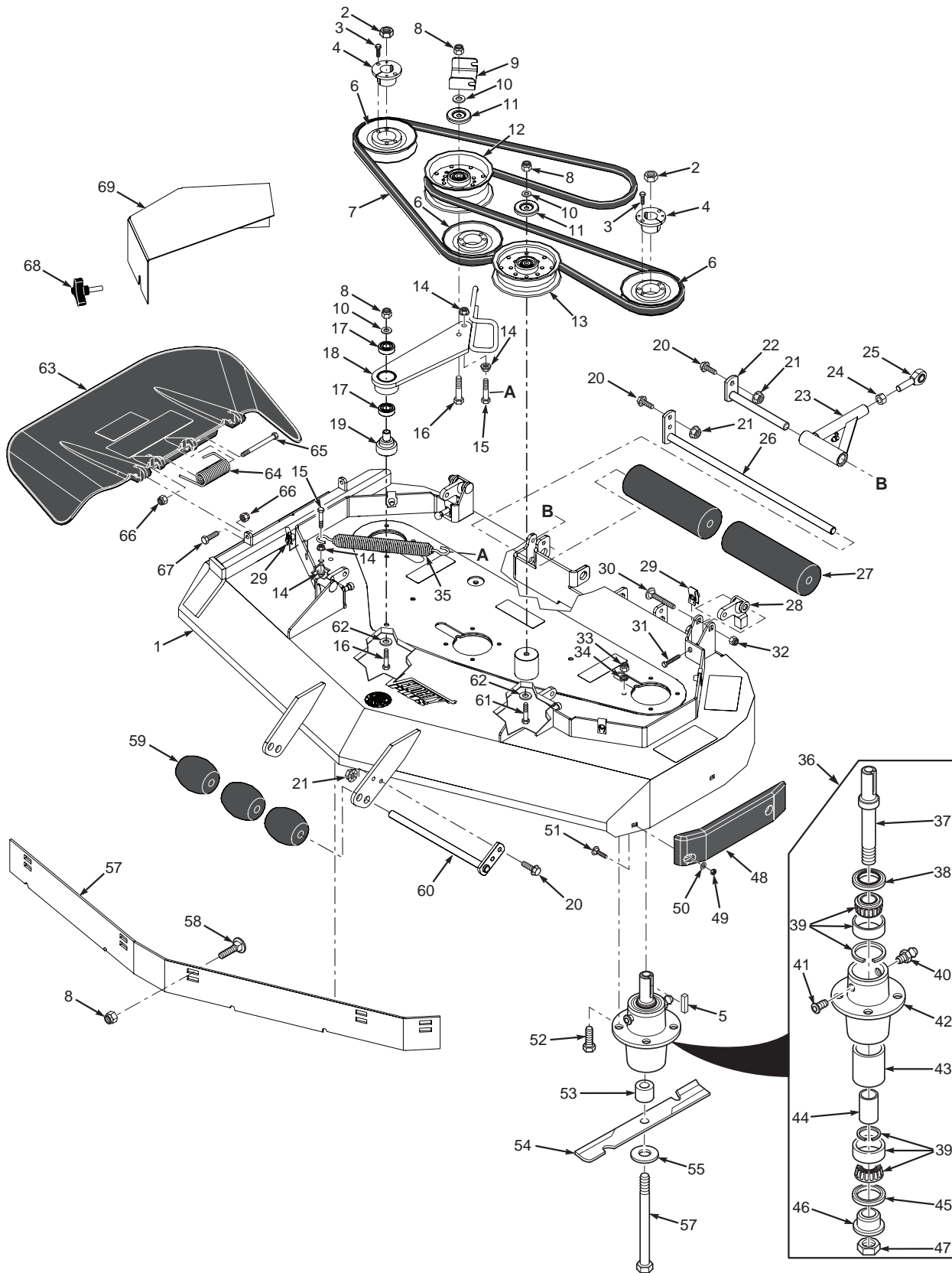

48V & 52V CUTTER DECKS

Ref. No.	Part No.	Description
1	462237	Cutter Deck w/Decals (48V)
	462238	Cutter Deck w/Decals (52V)
2	04020-09	Nut, 5/8-11 UNC
3	04001-172	Bolt, Hex Head 1/4-20 x 1"
4	48926	Tapered Hub
5	04063-08	Key, 1/4 x 1/4 x 1"
6	483282	Pulley, 5.13 OD (48V)
	483284	Pulley, 5.73 OD (52V)
7	483966	Belt, Cutter Deck (48V)
	484100	Belt, Cutter Deck (52V)
8	04021-09	Nut, Elastic Stop 3/8-16
9	424615	Bracket, Belt Guide
10	04043-04	Flatwasher, 3/8-.391 x .938 x .105 HD
11	424367	Dust Shield
12	483210	Pulley, 5" Idler
13	483215	Pulley, 5" Idler
14	04019-04	Nut, Serrated Flange 3/8-16
15	04001-136	Bolt, Hex Head 3/8-16 x 1-1/2" Gr.8
16	04001-62	Bolt, Hex Head 3/8-16 x 3-1/4"
17	48224	Bearing
18	462234	Idler Arm Assembly - 48V (Incl. # 17)
	462235	Idler Arm Assembly - 52V (Incl. #17)
19	43681	Pivot, Idler
20	04001-09	Bolt, Hex Head 5/16-18 x 1"
21	04019-03	Nut, Serrated Flange 5/16-18
22	451724	Shaft Weldment, Pusharm Mount
23	461755	Pusharm Assembly, LH
	461756	Pusharm Assembly, RH
24	04020-08	Nut, 1/2-20 UNF
25	48542	Rod End, 1/2-20 RH
26	452076	Shaft Weldment
27	483997	Guide Roller
28	483361	Lever, Deck Level
29	04110-03	U-Nut, 3/8-16
30	04003-42	Bolt, Carriage 7/16-14
31	04107-04	Bolt, Hex Head 3/8-16 x 2" Special
32	04021-11	Nut, Elastic Stop 7/16-14
33	04021-22	Nut, Elastic Stop 5/16-18
34	04030-03	Lockwasher, 5/16" Spring
35	484020	Spring, Cutter Deck
36	461663	Spindle Assembly
37	43589	Shaft, Spindle
38	481024	Seal, Upper
39	481022	Bearing Assembly
40	48114-04	Grease Fitting
41	48677	Valve Grease Relief
42	43644	Housing, Spindle
43	43312	Spacer, Outside
44	43296	Spacer, Inside

Ref. No.	Part No.	Description
45	481025	Seal, Lower
46	43297	Bushing, Lower
47	481035	Nut, Special 1-1/16" - 18
48	483176	Pad, Deck Wear
49	04021-04	Nut, Center Lock 5/16-18
50	04040-04	Flatwasher, 5/16-.344 x .688 x .065
51	04003-12	Bolt, Carriage 5/16-18 x 3/4"
52	04001-176	Bolt, Hex Head 5/16-18 x 1-3/4"
53	43590	Spacer, Spindle Bottom
54	482877	Cutter Blade, 16-1/2" (48V)
	482878	Cutter Blade, 18" (52V)
55	04043-06	Flatwasher, 5/8-.688 x 1.75 x .134 HD
56	04001-41	Bolt, Hex Head 5/8-11 x 9-1/2"
57	424839	Baffle, Flange 48V
	424840	Baffle, Flange 52V
58	04003-23	Bolt, Carriage 3/8-16 x 1"
59	482295	Wheel Anti-Scalp
60	45944	Shaft Weldment
61	04001-47	Bolt, Carriage 3/8-16 x 5"
62	04041-38	Flatwasher, 3/8-.406 x 2.25 x .1875
63	461844	Discharge Chute Assembly - 48V
	461845	Discharge Chute Assembly - 52V
64	482245	Spring, Discharge Chute
65	04001-154	Bolt, Hex Head 5/16-18 x 4-3/4"
66	04021-10	Nut, Elastic Stop 5/16-18
67	04001-12	Bolt, Hex Head 5/16-18 x 1-3/4"
68	481625-01	Knob w/Stud
69	425095	Belt Cover, RH (48V)
	425364	Belt Cover, RH (52V)
	425094	Belt Cover, LH (48V)
	425363	Belt Cover, LH (52V)

CUTTER DECK CONTROLS

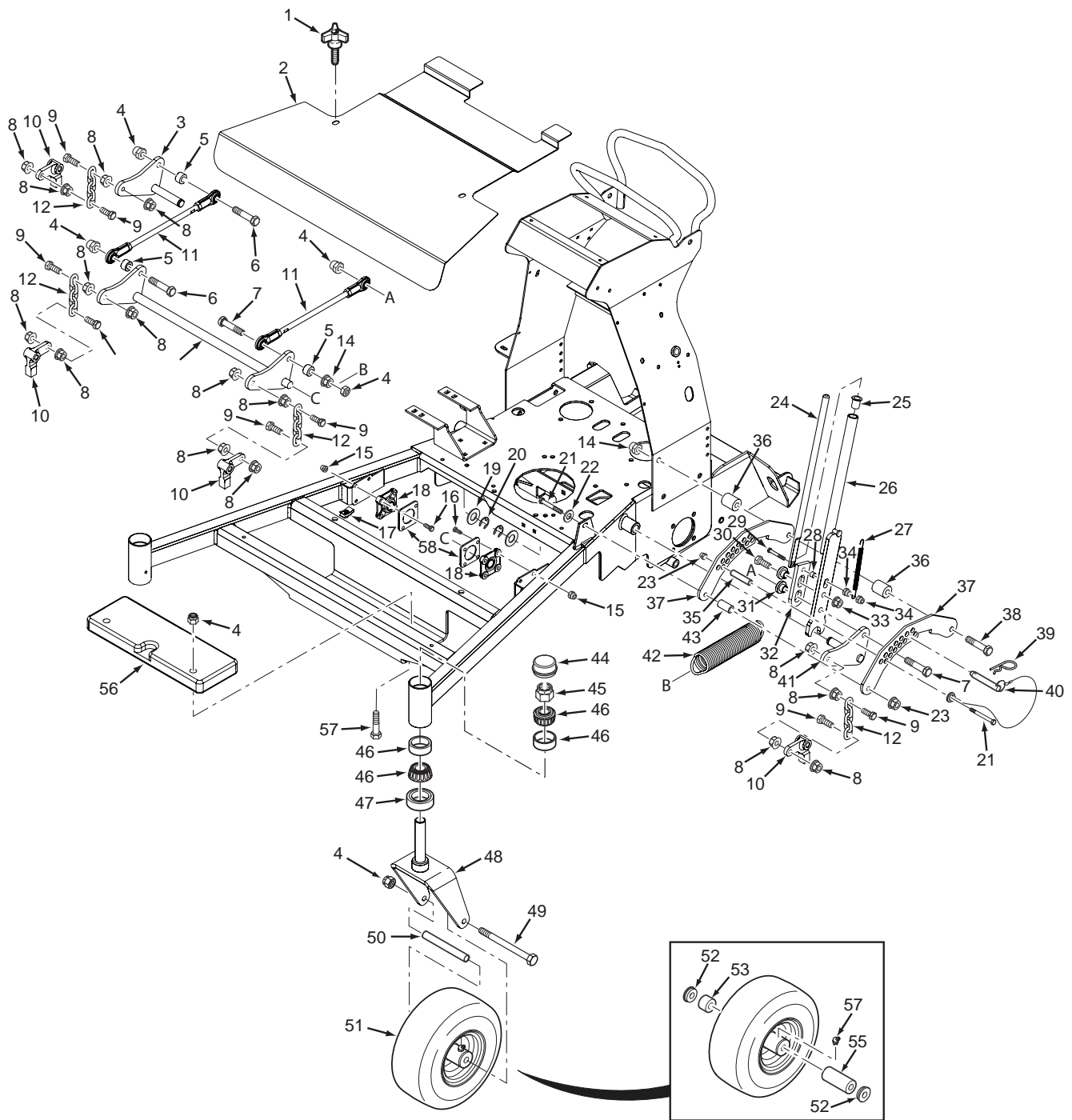

CUTTER DECK CONTROLS

Ref. No.	Part No.	Description
1	481625-01	Knob w/Stud
2	491536	Belt Cover w/Decals (36A)
	491537	Belt Cover w/Decals (48V & 52V)
3	452063	Arm Weldment, RH
4	04021-07	Nut, Elastic Stop 1/2-13
5	43806	Spacer
6	04001-52	Bolt, Hex Head 1/2-13 x 2-1/2"
7	04001-74	Bolt, Hex Head 1/2-13 x 3"
8	04019-04	Nut, Serrated Flange 3/8-16
9	04001-20	Bolt, Hex Head 3/8-16 x 1-1/2"
10	483361	Lever, Deck Level
11	483987	Linkage, Deck Lift (36A)
	483876	Linkage, Deck Lift (48V & 52V)
12	48540	Chain
13	452057	Deck Lift Weldment (36A)
	452053	Deck Lift Weldment (48V & 52V)
14	04019-06	Nut, Serrated Flange 1/2-13
15	04021-10	Nut, Elastic Stop 5/16-18
16	04001-09	Bolt, Hex Head 5/16-18 x 1"
17	04110-04	U-Nut, 3/8-16
18	483628	Bearing, Deck Lift - 36A
	483334	Bearing, Deck Lift - 48V & 52V
19	04041-08	Flatwasher, 3/4-.766 x 1.25 x .0598
20	04050-02	Retaining Ring, .750 "E"
21	04001-54	Bolt, Hex Head 3/8-16 x 3"
22	04041-07	Flatwasher, 3/8-.391 x .938 x .105
23	04021-09	Nut, Elastic Stop 3/8-16
24	43747	Actuator Rod
25	483453-14	Bearing
26	452061	Handle Weldment, Deck Latch
27	483600	Spring, Deck Latch
28	43212	Spacer
29	04001-31	Bolt, Hex Head 3/8-16 x 2-1/2"
30	04001-183	Bolt, Hex Head 1/2-13 x 1-3/4"
31	43748	Bushing, Deck Latch
32	424652	Deck Latch, Outer
33	04019-06	Nut, Serrated Flange 1/2-13
34	04021-09	Nut, Elastic Stop 3/8-16
35	43554	Spacer
36	43666	Spacer
37	425064	Bracket, Deck Height
38	04001-82	Bolt, Hex Head 1/2-13 x 4-1/2"
39	04062-04	Hair Pin Cotter
40	483345	Pin Assembly w/Lanyard
41	452062	Arm Weldment, LH
42	483763	Spring, Deck Lift
43	43805	Spacer
44	481559	Cap, Grease

Ref. No.	Part No.	Description
45	04021-20	Nut, Elastic Stop 1"-14
46	481657	Bearing w/Race
47	481025	Seal, 2" OD x 1.625 ID
48	452034	Caster Yoke Weldment
49	04001-80	Bolt, Hex Head 1/2-13 x 6-1/2"
50	43511	Sleeve, Caster Wheel
51	9276	Caster Wheel Assembly, 11 x 4.0-5
52	481770	Bearing, Oilite
53	481846	Roller Bearing, Short
54	48114-03	Grease Fitting, 45 Degree
55	481769	Roller Bearing, Long
56	41020	Weight
57	04001-190	Bolt, Hex Head 1/2-13 x 2-3/4" (48V & 52V - One Weight)
	04001-82	Bolt, Hex Head 1/2-13 x 4-1/2" (36A - Two Weights)
	04001-37	Bolt, Hex Head 1/2-13 x 5-1/2" (Three Weights Installed)
58	425099	Reinforcement, Bearing - 36A (not shown)
	425209	Reinforcement, Bearing - 48V & 52V

SHEET METAL COMPONENTS

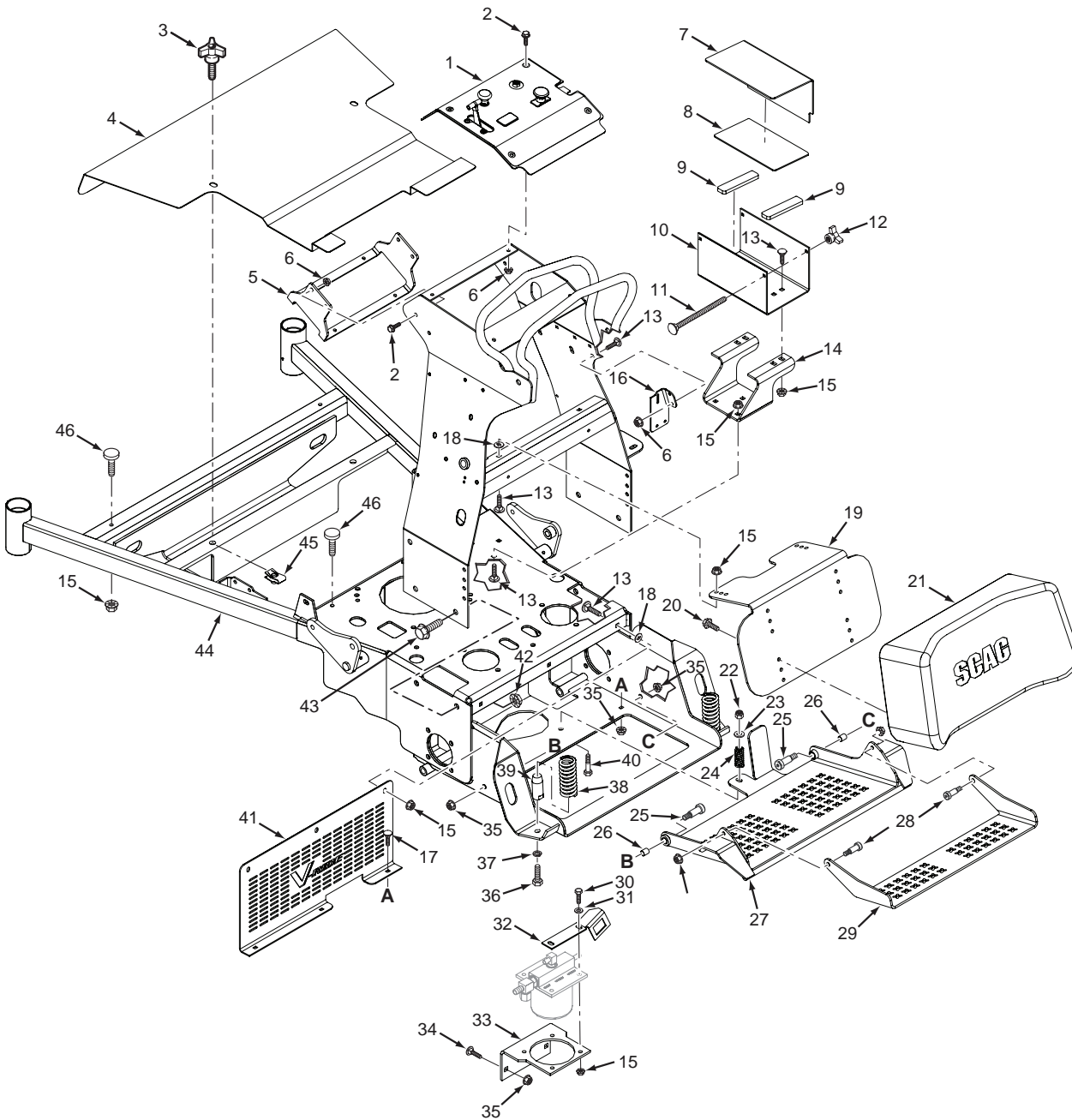

SHEET METAL COMPONENTS

Ref. No.	Part No.	Description
1	462240	Instrument Panel w/Decal
2	04001-06	Bolt, Hex Head 1/4-20 x .63
3	481625-01	Knob w/Stud
4	491536	Belt Cover w/Decals - 36A
	491537	Belt Cover w/Decals - 48V & 52V
5	425229	Bracket, Oil Cooler - 48V & 52V Only
6	04019-02	Nut, Serrated Flange 1/4-20
7	42392	Battery Cover
8	48099	Insulation, Battery Cover
9	48661	Pad, Rubber
10	423308	Battery Box
11	04003-01	Bolt, Carriage 1/4-20 x 6"
12	04029-01	Wing Nut, 1/4-20
13	04003-12	Bolt, Carriage 5/16-18 x 3/4"
14	425085	Bracket, Battery Support
15	04019-03	Nut, Serrated Flange 5/16-18
16	425307	Bracket, Neutral Switch
17	04003-02	Bolt, Carriage 1/4-20 x 3/4"
18	04024-03	Nut, Push On 5/16"
19	425148	Bracket, Knee Pad
20	04017-05	Bolt, Hex Head 1/4-20 x 3/4"
21	483963	Knee Pad
22	04021-09	Nut, Elastic Stop 3/8-16
23	04040-12	Flatwasher, 3/8-.438 x 1" x .083
24	48807	Spring
25	04009-09	Bolt, Shoulder 1/2 x 1"
26	483453-19	Bearing
27	462223	Footplate Assembly (Incl. # 26)
28	04009-15	Bolt, Shoulder 3/8 x 1/4"
29	425152	Footplate Extension

Ref. No.	Part No.	Description
30	04001-09	Bolt, Hex Head 5/16-18 x 1
31	04040-04	Flatwasher, 5/16-.344 x .688 x .065
32	425288	Switch Bracket, Operator Presence
33	425084	Bracket, Oil Filter Base
34	04001-19	Bolt, Hex Head 3/8-16 x 1"
35	04019-04	Nut, Serrated Flange 3/8-16
36	04001-18	Bolt, Hex Head 3/8-16 x 3/4"
37	04030-04	Lockwasher, 3/8"
38	484041	Spring, Foot Platform
39	43814	Pin, Spring Mount
40	04001-51	Bolt, Hex Head 3/8-16 x 3-3/4"
41	425036	Guard, Foot
42	04112-05	Locknut, 1/2-13 Spiral Lock
43	04017-36	Bolt, Serrated Flange 1/2-13 x 1"
44	462230	Mainframe Assembly w/Decals (36)
	462231	Mainframe Assembly w/Decals (48)
	462232	Mainframe Assembly w/Decals (52)
45	04110-04	U-Nut, 3/8-16
46	481284	Bumper, Rubber
47	452121	Handle Weldment

STEERING CONTROLS AND FUEL COMPONENTS

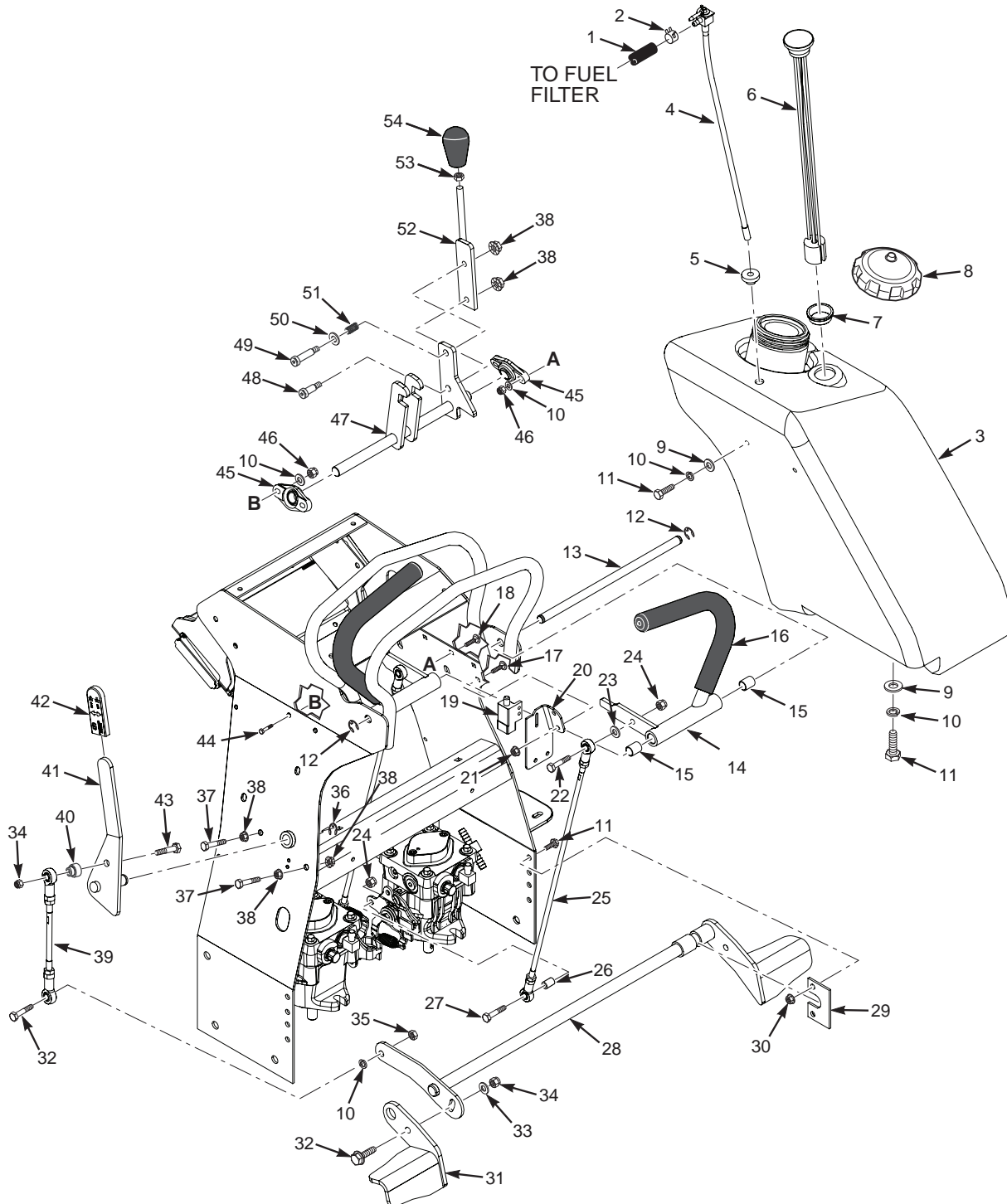

STEERING CONTROLS AND FUEL COMPONENTS

Ref. No.	Part No.	Description
1	483617	Fuel Hose 1/4" ID (Order by Inch)
2	48059-01	Clamp, Fuel Hose 1/4" ID
3	462177	Fuel Tank Assy. (Incl. #4, 5, 6, 7)
4	483896	Valve, Fuel Shut Off
5	482571	Bushing, .56 Viton
6	483897	Fuel Gauge Assembly
7	483536	Grommet, Fuel Gauge
8	483792	Cap, Fuel Tank
9	04040-15	Flatwasher, 5/16-.375 x .875 x .083
10	04030-03	Lockwasher, 5/16" Spring
11	04001-08	Bolt, Hex Head 5/16-18 x 3/4"
12	04050-10	Retaining Ring, .50 External
13	43820	Shaft, Steering Handles
14	462220	Handle Bar Assy., LH (Incl. # 15, 16)
	462221	Handle Bar Assy., RH (Incl. # 15, 16)
15	483453-19	Bearing
16	484092	Grip, Control Lever
17	04003-02	Bolt, Carriage 1/4-20 x 3/4"
18	04003-06	Bolt, Carriage 1/4-20 x 1"
19	481545	Switch, Interlock
20	425307	Bracket, Neutral Switch
21	04019-02	Nut, Serrated Flange 1/4-20
22	04001-10	Bolt, Hex Head 5/16-18 x 1-1/4"
23	04040-04	Flatwasher, 5/16-.344 x .688 x .065
24	04021-10	Nut, Elastic Stop 5/16-18
25	484072	Linkage Assembly
26	43749	Spacer, Pump
27	04001-12	Bolt, Hex Head 5/16-18 x 1-3/4"
28	452054	Bellcrank, Brake Weldment
29	425079	Brake Keeper Plate
30	04019-03	Nut, Serrated Flange 5/16-18

Ref. No.	Part No.	Description
31	452055	Brake Weldment, LH
32	04001-32	Bolt, Hex Head 3/8-16 x 1-1/4"
33	04040-12	Flatwasher, 3/8-.438 x 1.0 x .083
34	04021-09	Nut, Elastic Stop 3/8-16
35	04021-05	Nut, Center Lock 3/8-16
36	04050-01	Retaining Ring, .625 External "E"
37	04001-11	Bolt, Hex Head 5/16-18 x 1-1/2"
38	04019-03	Nut, Serrated Flange 5/16-18
39	484090	Linkage Assembly, Brake
40	43750	Spacer
41	462241	Brake Lever w/Grip
42	481548	Grip, Brake Lever
43	04001-45	Bolt, Hex Head 3/8-16 x 2"
44	04001-14	Bolt, Hex Head 1/4-20 x 1"
45	483504	Bearing
46	04021-08	Nut, Elastic Stop 1/4-20
47	452117	Lock Weldment, Neutral
48	04009-14	Bolt, Shoulder 3/8 x .375
49	04009-11	Bolt, Shoulder 3/8 x 1"
50	04050-05	Flatwasher, 3/8-.406 x .812 x .065
51	483601	Spring, Neutral Lever
52	452118	Handle Weldment
53	04020-12	Nut, Jam 3/8-16
54	484093	Knob, Soft Touch

HYDRAULICS AND ENGINE COMPONENTS

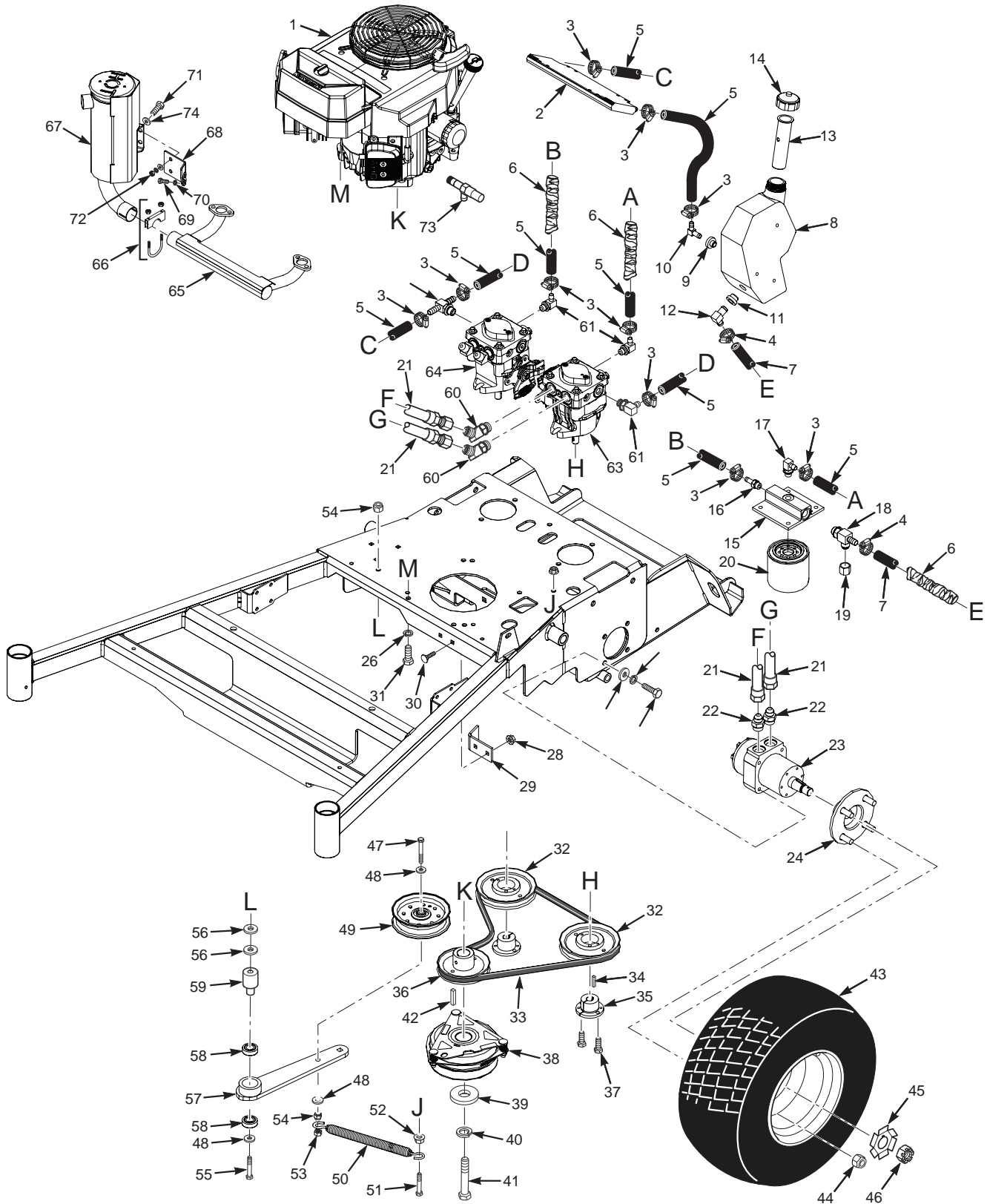

HYDRAULICS AND ENGINE COMPONENTS

Ref. No.	Part No.	Description	Ref. No.	Part No.	Description
1	484101	Engine, 20hp Kawasaki FX	42	04063-28	Key, 1/4 x 1/4 x 3-1/2"
	484102	Engine, 24hp Kawasaki FX	43	483657	Wheel Assy., 18 x 7-8 (36)
	483968	Engine, 26hp Kawasaki FX		483658	Rim w/Valve Stem (36)
2	482708	Cooler, Transmission (48 & 52 Only)		483659	Tire, 18 x 7-8 (36)
3	48136-13	Clamp, .69 Max Dia.		484056	Wheel Assy., 20 x 10.5-8 (48 & 52)
4	48136-05	Clamp, .87 Max Dia.		481868	Rim w/Valve Stem (48 & 52)
5	48811	Hose, 3/8 Pushlock (order by inch)		484057	Tire, 20 x 10.5-8, 4-Ply (48 & 52)
6	482839	Heatshield, Flexible	44	04028-02	Wheel Nut
7	48351	Hose, 1/2 Pushlock (order by inch)	45	422214	Lockwasher, Wheel Motor
8	462176	Hydraulic Tank Assy. (incl. # 9 through 13)	46	HG53625	Hex Castle Nut, Wheel Motor
9	482571	Bushing, .56 Dia, Viton	47	04001-161	Bolt, Hex Head 3/8-16 x 2-3/4"
10	482572	Fitting, 90 Degree - .38 Hose	48	04043-04	Flatwasher, 3/8-.391 x .938 x .105 HD
11	482573	Bushing, .78 Dia. Viton	49	483213	Pulley, 4-1/2" Idler
12	48254	Fitting, 90 Degree - .50 Hose	50	483526	Spring, Transmission
13	481507	Insert, Filler Neck	51	04001-54	Bolt, Hex Head 3/8-16 x 3"
14	481164	Cap, Hydraulic Tank	52	04019-04	Nut, Serrated Flange 3/8-16
15	482417	Filter Head	53	04021-05	Nut, Center Lock 3/8-16
16	482800-02	Fitting	54	04021-09	Nut, Elastic Stop 3/8-16
17	482266-01	Elbow, 90 Degree	55	04001-62	Bolt, Hex Head 3/8-16 x 3-1/4"
18	482481	Tee Fitting, 3/4 O-Ring	56	04041-12	Flatwasher, 3/8-.375 x 1-1/2 x .059
19	48571-02	Cap, 3/4" JIC	57	462229	Idler Arm Assy (incl. # 58)
20	48462-01	Oil Filter	58	48224	Bearing
21	483951	Hose Assembly	59	43734	Idler Pivot, Long
22	48572-02	Fitting, Union 1/2 x 5/8	60	48485-01	Elbow, 45 Degree
23	483807	Wheel Motor, Hydro-Gear	61	482266-01	Elbow, 90 Degree
24	46928	Wheel Hub Assembly	62	482277	Fitting, Tee
25	04001-19	Bolt, Hex Head 3/8-16 x 1"	63	483863	Pump, LH
26	04030-04	Lockwasher, 3/8" Spring	64	483862	Pump, RH
27	04040-05	Flatwasher, 3/8-.406 x .812 x .065	65	484067	Exhaust Manifold, SVR (48 & 52 Only)
28	04019-03	Nut, Serrated Flange 5/16-18	66	48633	Clamp, Muffler (48 & 52 Only)
29	425213	Bracket, Anti-Rotation (36")	67	484030	Muffler, Kawasaki (48 & 52 Only)
	425086	Bracket, Anti-Rotation (48" & 52")	68	425368	Bracket, Muffler (48 & 52 Only)
30	04003-04	Bolt, Carriage 5/16-18 x 1"	69	04002-06	Bolt, Hex Head M8 - 1.25 X 16
31	04001-32	Bolt, Hex Head 3/8-16 x 1-1/4"	70	04030-03	Lockwasher, 5/16" Spring
32	482649	Pulley, 5.45 OD Tapered Bore	71	04001-09	Bolt, Head Head 5/16-18 x 1"
33	483520	Belt, Pump Drive	72	04020-03	Nut, 5/16-18
34	04063-14	Key, 5 x 5 x 25mm	73	484089	Oil Drain
35	482085	Tapered Hub, 15mm Bore	74	04040-04	Flatwasher, 5/16-.344 x .688 x .065
36	483802	Pulley, 4.75 OD - 1.125 Bore			
37	04001-172	Bolt, Hex Head 1/4-20 x 1" Gr. 8			
38	462166	Clutch w/Tag			
39	04041-28	Flatwasher, 7/16-.469 x 1.75 x .25			
40	04030-05	Lockwasher, 7/16" Spring			
41	04102-03	Bolt, Hex Head 7/16-20 x 2-1/4" Patch			

ELECTRICAL SYSTEM

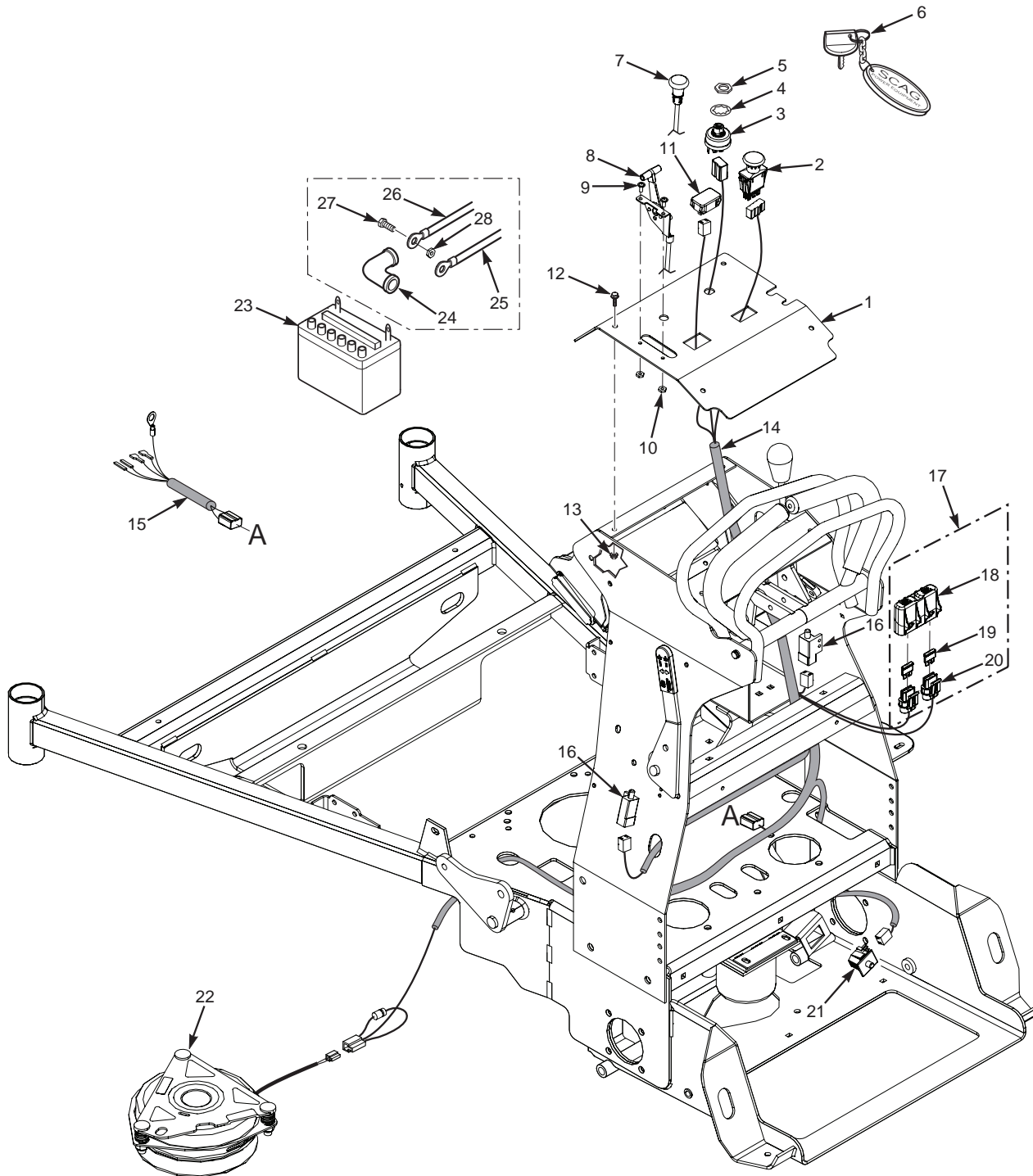

ELECTRICAL SYSTEM

Ref. No.	Part No.	Description
1	462240	Instrument Panel w/Decal
2	483957	Switch, PTO - 10 Amp
3	48798	Key Switch
4	48017-03	Lockwasher, 5/8" Internal Tooth
5	48017-04	Nut, 5/8-32 Special
6	462069	Key Chain w/ Keys
	483609	Key w/Shroud
7	483976	Choke Control, SVR
8	483975	Throttle Control, SVR
9	04003-43	Bolt, Carriage #10-24 x 1/2"
10	04021-26	Locknut, #10-24
11	483537	Hourmeter
12	04001-06	Bolt, Hex Head 1/4-20 x .63
13	04019-02	Nut, Serrated Flange 1/4-20
14	484157	Wire Harness, SVR
15	482543	Wire Harness Adapter, Kawasaki
16	481637	Switch, Interlock
17	483642	Double Fuse Assy. (incl. #18, 19, 20)
18	483571	Cover, Sealed Double
19	48298	Fuse, 20 Amp
20	483629	Fuse Holder
	482588	Clip (not shown)
21	483473	Switch, Double Pole - Plunger
22	462166	Clutch w/Tag
23		Battery (not avail. through Scag)
24	48126	Rubber Boot
25	48029-07	Cable, Battery Black 18"
26	48029-06	Cable, Battery Red 18"
27	04001-01	Bolt, Hex Head 1/4-20 x 3/4"
28	04020-02	Nut, 1/4-20

HYDRAULIC PUMP ASSEMBLY

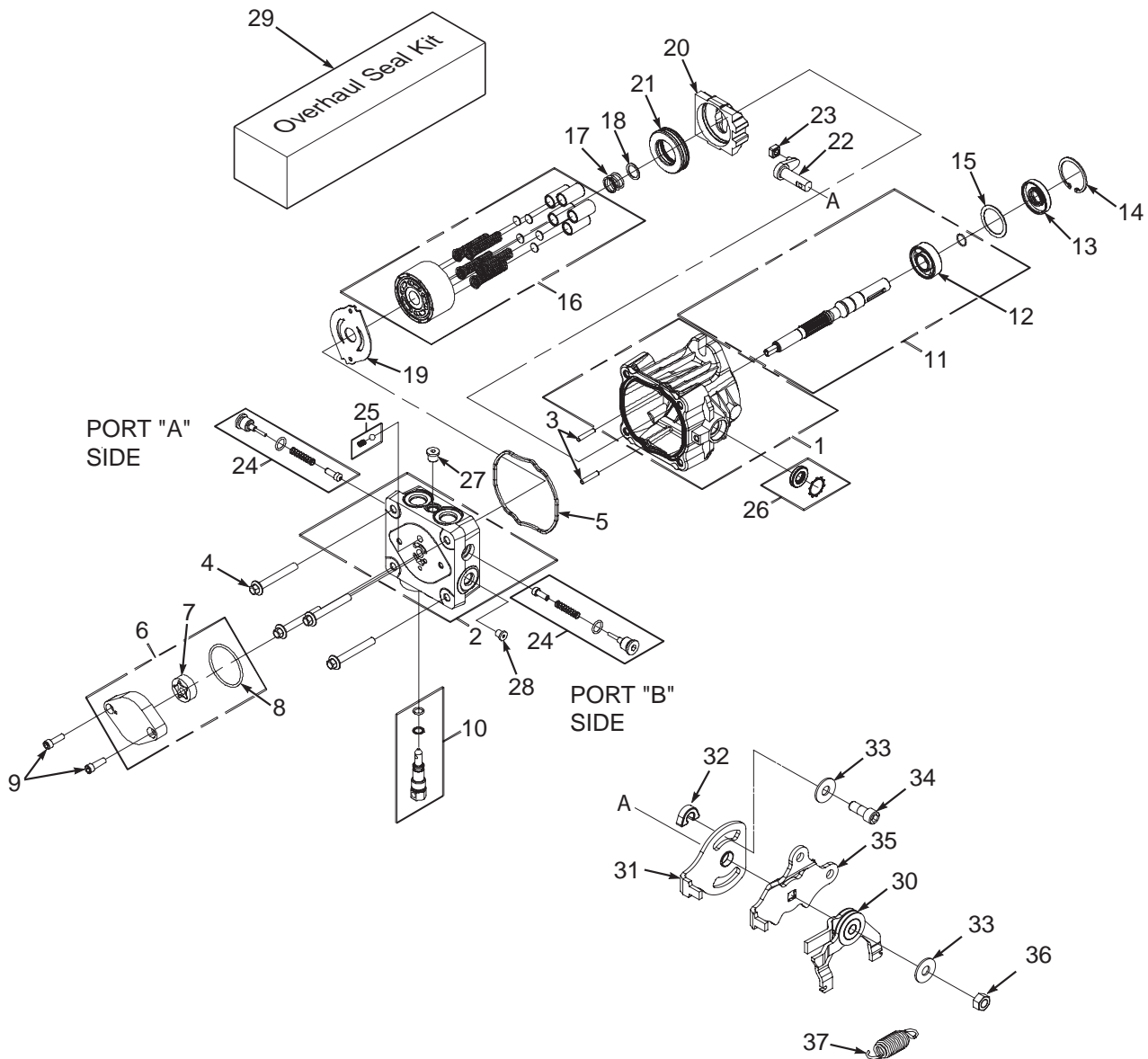

HYDRAULIC PUMP ASSEMBLY

Ref. No.	Part No.	Description
1	HG 70516	Housing Kit
2	HG 70573	End Cap Kit
3	HG 50641	Straight Headless Pin
4	HG 50969	Hex Flange Bolt, M8-1.25 x 60mm
5	HG 51232	Housing O-Ring
6	HG 2513027	Charge Pump Kit
7	HG 50273	Gerotor Assembly
8	HG 9004101-1340	O-Ring
9	HG 50095	Socket Head Screw, M6 x 1.0-20mm
10	HG 2513030	Bypass Valve Kit
11	HG 70521	Pumpshaft Kit
12	HG 50315	Ball Bearing, 17 x 40 x 12
13	HG 51161	Lip Seal
14	HG 50329	Retaining Ring
15	HG 50951	Spacer
16	HG 70331	Cylinder Block Kit
17	HG 2003014	Block Spring
18	HG 2003017	Block Thrust Washer
19	HG 51444	Valve Plate
20	HG 2003087	Swash Plate
21	HG 50551	Ball Thrust Bearing
22	HG 2003005	Trunnion Arm
23	HG 2000015	Slot Guide
24	HG 2510062	Check Valve Kit (.024" Orifice) port "A" on Left Hand Pump, port "B" on Right Hand Pump
25	HG 70403	Charge Relief Kit
26	HG 2513043	Trunnion Seal with Retainer
27	HG 9005110-4400	Straight Thread Plug
28	HG 50408	Straight Headless Pin
29	HG 70525	Overhaul Seal Kit
30	HG52413	Assembly, RTN
31	HG51391	Arm, Return
32	HG51561	Spacer
33	HG44130	Washer
34	HG51400	Screw, 5/16-24 x 3/4" Patch
35	HG51394	Control Arm
36	HG52506	Nut, Center Lock 5/16-24 UNF
37	HG52401	Spring, Extension

REPLACEMENT DECALS AND INFORMATION PLATES

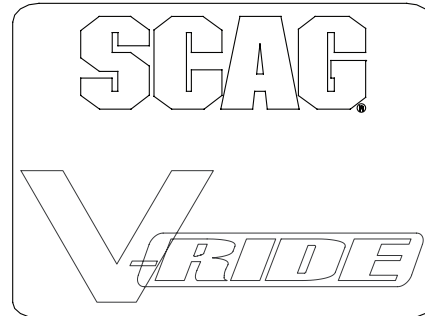
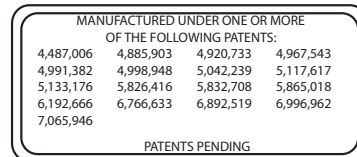
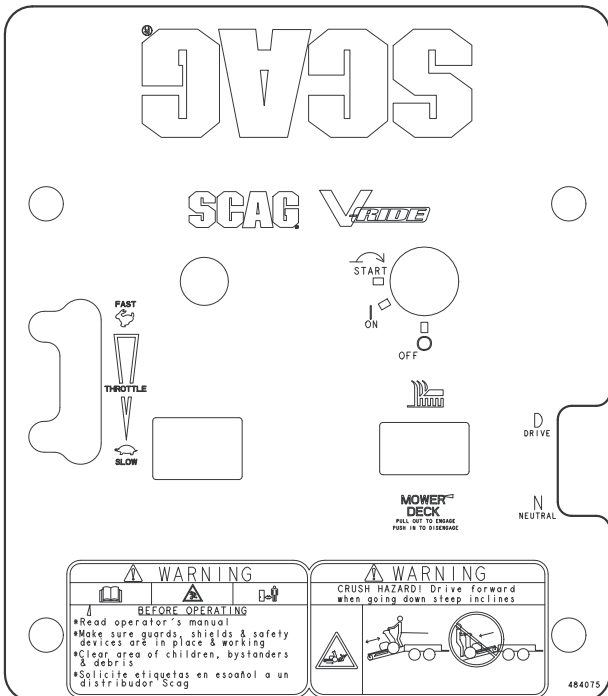
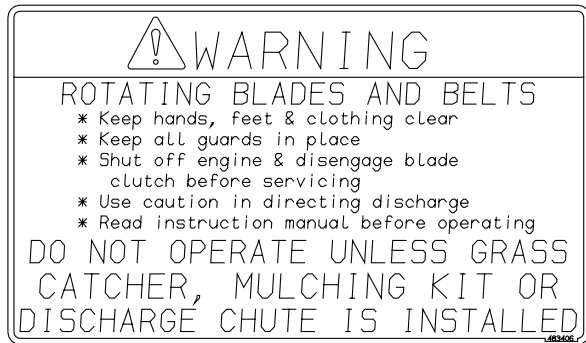
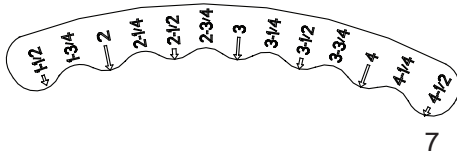
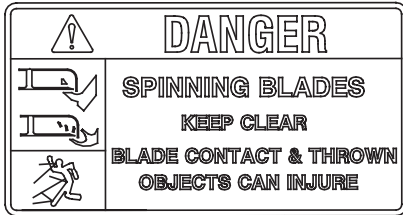

10

REPLACEMENT DECALS AND INFORMATION PLATES

Ref. No.	Part No.	Description
1	483402	Decal, Warning - Belt Cover
2	483405	Decal, Warning
3	483961	Decal, Belt Cover
4	483059	Decal, 36A
	483199	Decal, 48V
	483200	Decal, 52V
5	483407	Decal, Spinning Blades
6	48404	Decal, Metalcraft - Made in USA
7	483977	Decal, Height-of-Cut
8	483406	Decal, Warning - Knives
9	481971	Decal, Heavy Duty Commercial
10	484075	Decal, Instrument Panel
11	483044	Decal, Patents

SVR ELECTRICAL SCHEMATIC

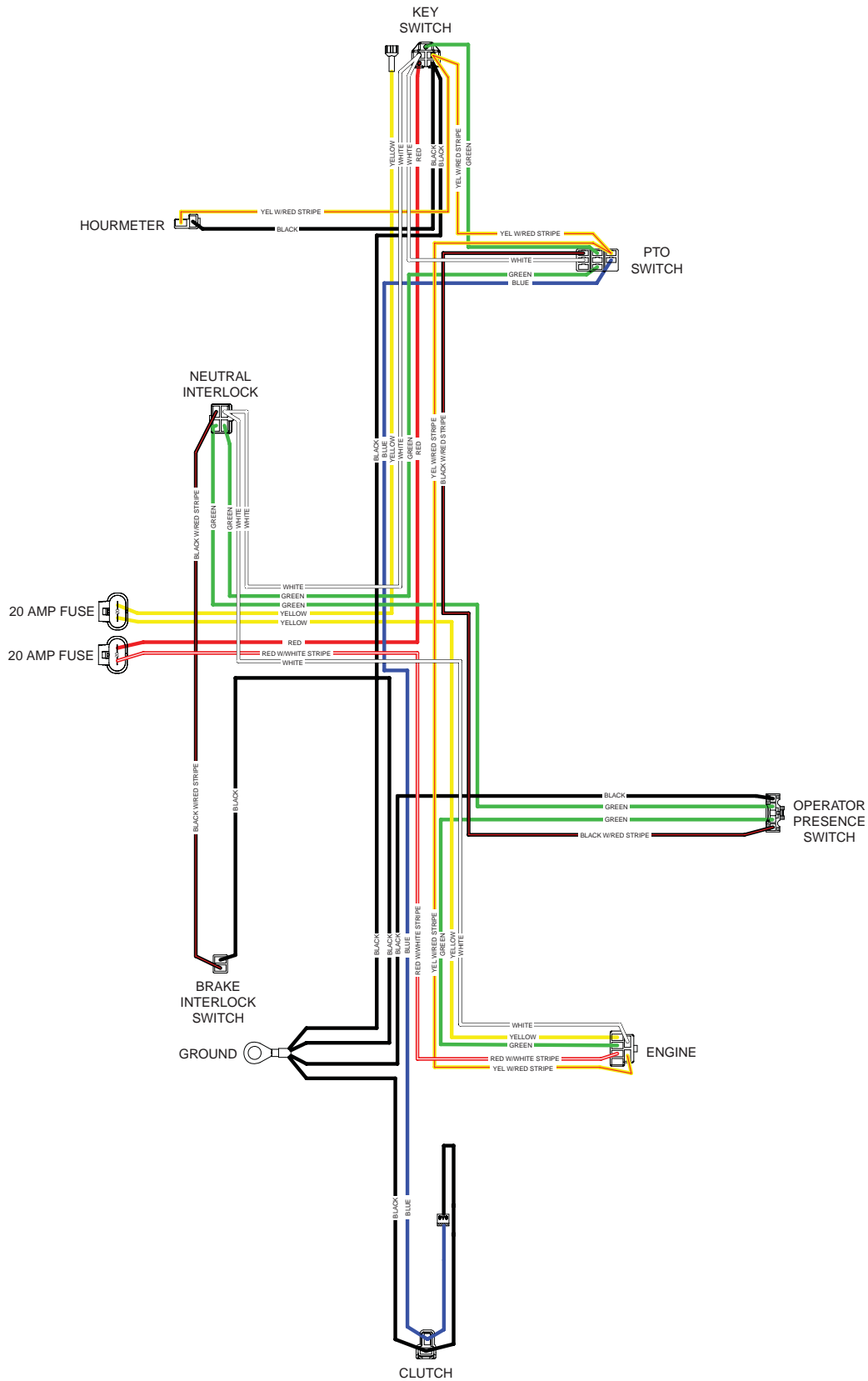

LIMITED WARRANTY - COMMERCIAL EQUIPMENT

Any part of the Scag commercial mower manufactured by Scag Power Equipment and found, in the reasonable judgment of Scag, to be defective in materials or workmanship, will be repaired or replaced by an Authorized Scag Service Dealer without charge for parts and labor during the periods specified below. This warranty is limited to the original purchaser and is not transferable. Proof of purchase will be required by the dealer to substantiate any warranty claims. All warranty work must be performed by an Authorized Scag Service Dealer.

This warranty is limited to the following specified periods from the date of the original retail purchase for defects in materials or workmanship:

- Wear items including drive belts, blades, hydraulic hoses and tires are warranted for ninety (90) days.
- Batteries are covered for ninety (90) days.
- Frame and structural components including oil reservoir and oil coolers are warranted for two (2) years (parts and labor) for commercial use or three (3) years / 500 hours (whichever comes first) (parts and labor) for non-commercial use.
- Cutter decks are warranted against cracking for a period of three (3) years. (parts and labor 1st and 2nd year; parts only 3rd year.) The repair or replacement of the cutter deck will be at the option of Scag Power Equipment. We reserve the right to request components for evaluation. This warranty does not cover any mower that has been subject to misuse, neglect, negligence, or accident, or that has been operated in any way contrary to the operating instructions as specified in the Operator's Manual.
- Engines and electric starters are covered by the engine manufacturer's warranty period.
- Major drive system components are warranted for two (2) years (parts and labor) for commercial use or three (3) year / 500 hour (whichever comes first) (parts and labor) for non-commercial use by Scag Power Equipment. (commercial and non-commercial warranty excludes fittings, hoses, drive belts). The repair or replacement of the hydraulic pump or hydraulic motor will be at the option of Scag Power Equipment. This warranty does not cover any mower that has been subject to misuse, neglect, negligence, or accident, or that has been operated in any way contrary to the operating instructions as specified in the Operator's Manual.
- Electric clutches have a Limited Warranty for two (2) years (parts and labor) for commercial use or three (3) year / 500 hours (whichever comes first) (parts and labor) for non-commercial use.
- Spindle assemblies have a Limited Warranty for three years (parts and labor 1st year and 2nd; parts only 3rd year).
- Any Scag product used for rental purposes is covered by a 90 day warranty.

The Scag mower, including any defective part must be returned to an Authorized Scag Service Dealer within the warranty period. The expense of delivering the mower to the dealer for warranty work and the expense of returning it to the owner after repair will be paid for by the owner. Scag's responsibility is limited to making the required repairs and no claim of breach of warranty shall be cause for cancellation or rescission of the contract of sale of any Scag mower. "Non-Commercial" use is defined as a single property owner, where the single property is the residence of the owner of the mower. If the mower is cutting more than the owners single property, it is deemed commercial use and the "non-commercial" warranty does not apply. Scag Power Equipment reserves the right to deny and / or void the non-commercial warranty if it believes it to be in commercial use.

This warranty does not cover any mower that has been subject to misuse, neglect, negligence, or accident, or that has been operated in any way contrary to the operating instructions as specified in the Operator's Manual. The warranty does not apply to any damage to the mower that is the result of improper maintenance, or to any mower or parts that have not been assembled or installed as specified in the Operator's Manual and Assembly Manual. The warranty does not cover any mower that has been altered or modified, changing performance or durability. In addition, the warranty does not extend to repairs made necessary by normal wear, or by the use of parts or accessories which, in the reasonable judgment of Scag, are either incompatible with the Scag mower or adversely affect its operation, performance or durability.

Scag Power Equipment reserves the right to change or improve the design of any mower without assuming any obligation to modify any mower previously manufactured. All other implied warranties are limited in duration to the two (2) year for commercial use, three (3) years for non-commercial use or ninety (90) days for mowers used for rental purpose. Accordingly, any such implied warranties including merchantability, fitness for a particular purpose, or otherwise, are disclaimed in their entirety after the expiration of the appropriate two year or ninety day warranty period. Scag's obligation under this warranty is strictly and exclusively limited to the repair or replacement of defective parts and Scag does not assume or authorize anyone to assume for them any other obligation. Some states do not allow limitations on how long an implied warranty lasts, so the above limitation may not apply to you.

Scag assumes no responsibility for incidental, consequential or other damages including, but not limited to, expense for gasoline, expense of delivering the mower to an Authorized Scag Service Dealer and expense of returning it to the owner, mechanic's travel time, telephone or telegram charges, rental of a like product during the time warranty repairs are being performed, travel, loss or damage to personal property, loss of revenue, loss of use of the mower, loss of time or inconvenience. Some states do not allow the exclusion or limitation of incidental or consequential damages, so the above limitation or exclusion may not apply to you. This warranty gives you specific legal rights, and you may also have other rights which vary from state to state.

Free Manuals Download Website

<http://myh66.com>

<http://usermanuals.us>

<http://www.somanuals.com>

<http://www.4manuals.cc>

<http://www.manual-lib.com>

<http://www.404manual.com>

<http://www.luxmanual.com>

<http://aubethermostatmanual.com>

Golf course search by state

<http://golfingnear.com>

Email search by domain

<http://emailbydomain.com>

Auto manuals search

<http://auto.somanuals.com>

TV manuals search

<http://tv.somanuals.com>