

SCAG®

ZERO TURN RADIUS COMMERCIAL MOWERS TECHNICAL MANUAL

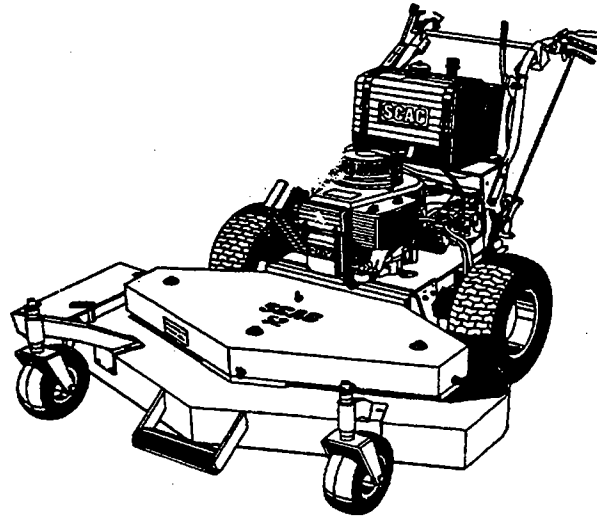

MODELS

SWZ-14KA
SWZ-14KH
SWZ-18KH
SWZ-20KHE

SWM-52
SWM-61
SWM-72

PATENT NO. 4,885,903

©1990
SCAG POWER EQUIPMENT, INC.
SUBSIDIARY OF METALCRAFT OF MAYVILLE

PART NO. 01060
PRINTED 1/90
PRINTED IN USA

TABLE OF CONTENTS

| SUBJECT | PAGE |
|-------------------------------|-------------|
| Safety Instructions | |
| Before Operating | 1 |
| While Operating | 1 |
| While Maintaining and Storing | 2 |
| Assembly Instructions | 2-4 |
| Adjustments | 5-6 |
| Initial Run-in | 7 |
| Operating Instructions | 7 |
| Maintenance | 8 |
| Lubrication/Maintenance Chart | 9 |
| 52", 61" & 72" Cutter Deck | 10-11 |
| Engine Deck | 12-14 |
| Replacement Decals | 15 |
| Handle Assembly | 16-18 |
| Wiring Diagram Electric Start | 19 |
| Wiring Diagram Manual Start | 20 |
| Warranty | 21 |

SAFETY INSTRUCTIONS

Your mower is only as safe as the operator! As with any type of power equipment, carelessness or error on the part of the operator may result in serious bodily injury. In addition, improper maintenance of the machine can also result in injury. To reduce the potential for injury, please read and follow these instructions on safe operation and be certain that anyone using this mower fully understands and complies with the following instructions.

BEFORE OPERATING

1. Read and understand the contents of this Technical Manual before operating the machine. Become familiar with all controls and know how to stop quickly. A free replacement manual is available by sending complete Model and Serial Number to:
Scag Power Equipment, Inc.
1000 Metalcraft Drive
Mayville, WI 53050
2. Do not allow children to operate the machine. Do not allow adults to operate the machine without proper instruction.
3. Before attempting to start engine, move speed adjustment lever to neutral position, move blade clutch lever into STOP position and move neutral latch to NEUTRAL LOCK.
4. Remove all debris or other objects that might be picked up and thrown by the cutter blades. Keep all bystanders away from the mowing area.
5. Keep all shields, safety devices, and decals in place. If a shield, safety device or decal is defective or damaged, repair or replace it before operation is commenced. Also, tighten all loose nuts, bolts and screws to assure machine is in safe operating condition.
6. Do not operate machine while wearing sandals, tennis shoes, sneakers or shorts. Also, do not wear loose fitting clothing which could get caught in moving parts. Always wear long pants and substantial shoes. Wearing safety glasses and safety shoes is advisable and required by some local ordinances and insurance regulations.
7. Fill fuel tank with gasoline before starting the engine. Avoid spilling gasoline. Since gasoline is flammable, handle it carefully.
 - A. Use an approved gasoline container.
 - B. Do not fill tank while engine is hot or running.
 - C. Do not smoke while handling gasoline.
 - D. Fill fuel tank outdoors and up to about one inch (25 mm) below the bottom of the filler neck.
 - E. Wipe up any spilled gasoline.
9. Do not run the engine in a confined area without adequate ventilation. Exhaust fumes are hazardous and could possibly be deadly.
10. Using the machine demands attention. To prevent loss of control:
 - A. Mow only in daylight or when there is good artificial light.
 - B. Watch for holes or other hidden hazards.
 - C. Do not drive close to a drop-off, ditch, creek or other hazard.
 - D. Reduce speed when making sharp turns and when turning on hillsides.
 - E. Always be sure of your footing. Keep a firm hold on the handle and walk--never run.
 - F. Do not operate where conditions are slippery.
11. The discharge chute must always be installed and in the down position on the side discharge cutting unit except when optional grass catcher is completely installed. If the cutting unit discharge should plug, shut engine off and wait for all movement to stop before removing obstruction.
12. Disengage the blades and wait for them to stop before crossing gravel drives, walks or roads.
13. Shut the engine off and wait until the blades come to a complete stop before removing the grass catcher container.
14. Never raise the cutting unit while the blades are rotating.
15. If the cutting blades should strike a solid object or the equipment should start to vibrate abnormally, stop the engine, disconnect the spark plug wire, and check immediately for the cause. Vibration is generally a warning of trouble. Check the cutting unit and traction unit for damaged or defective parts. Repair any damage before starting the engine and operating the cutter unit. Be sure blades are in good condition and blade bolts are tight.
16. Always park the mower and/or start the engine on a level surface. If this is not possible, block the wheels to prevent the mower from moving when you are not in the operator's position.
17. Cut grass slopes carefully. Do not start, stop or turn suddenly. Mow across the face of slopes; never up or down. Do not mow excessively steep slopes.
18. Do not touch engine or muffler while engine is running or soon after it is stopped. These areas could be hot enough to cause a burn.
19. Before leaving the operator's position or leaving mower unattended, move speed adjustment lever into NEUTRAL position, place neutral latches in NEUTRAL LOCK position, move cutter blade engagement lever to STOP and shut OFF engine.
20. Do not pass or stand on the grass discharge side of any mower with the engine running. Stop operation when another person approaches.

WHILE OPERATING

8. Start engine when neutral latches are in neutral lock position, cutter blades are disengaged, and speed adjustment lever is in neutral position.

ASSEMBLY INSTRUCTIONS

MAINTENANCE AND STORAGE

21. Disconnect high tension wire from spark plug to prevent accidental starting of the engine when servicing, adjusting or storing the machine.
22. If mower must be tipped to perform maintenance or adjustment, remove battery, drain gasoline from fuel tank and oil from crankcase.
23. To reduce potential fire hazard, keep the engine free of excessive grease, grass, leaves and accumulations of dirt.
24. Be sure machine is in safe operating condition by keeping nuts, bolts, and screws tight. Check the blade mounting bolts and nuts frequently to be sure they are tightened.
25. If the engine must be running to perform a maintenance adjustment, keep hands, feet, clothing and other parts of the body away from the cutting unit blades and other moving parts.
26. Do not overspeed the engine by changing governor settings. To be sure of safety and accuracy, have an authorized dealer check maximum engine speed with a tachometer.
27. Engine must be shut off before checking oil or adding oil to the crankcase.
28. Allow engine to cool before storing mower in any enclosure such as a garage or storage shed. Make sure the mower fuel tank is empty if machine is to be stored in excess of 30 days. Do not store mower near any open flame or where gasoline fumes may be ignited by a spark.
29. Always store gasoline in a safety-approved, red container.
30. Keep the mower and fuel container in locked storage to prevent children from playing and tampering with them.
31. Perform only those maintenance instructions described in this manual. If major repairs are ever needed or assistance is desired, contact an Authorized Scag Dealer. To ensure optimum performance and safety, always purchase genuine SCAG replacement parts and accessories. NEVER USE "WILL-FIT" replacement parts and accessories made by other manufacturers. Using unapproved replacement parts and accessories may void the warranty.
32. Be careful when servicing the battery as it contains acid, which is corrosive and could cause burns to skin and clothing.
33. Batteries release explosive gasses when being charged or discharged. KEEP away from any source of sparks and/or flame.

ELECTRIC START UNITS ONLY!

Before proceeding with assembly, prep the battery. Fill each cell with electrolyte until the top of the plates are covered, charge the battery at 3 to 4 amps for 4 hours (this insures a good initial charge), check and add electrolyte as needed to bring the fluid level to the bottom of the split ring, and then wash and dry off the battery.

NOTE: *Once the above fill and charge procedure has been completed only distilled water should be added to the battery cells.*

Set the battery into the support, connect the positive cable to the positive post, then connect the negative cable to the negative post, put the battery cover in place (at the back of the battery), and clamp the battery into place (finger tight) using the carriage bolts and wing nuts **DO NOT OVER TIGHTEN.**

⚠ WARNING: Severe chemical burns can result from improper handling of battery electrolyte. Use proper eye, skin and clothing protection to prevent contact with eyes, skin and clothing.

External contact: Flush with water.

Internal contact: Drink large quantities of water, followed with milk of magnesia, beaten egg or vegetable oil.

CALL A PHYSICIAN IMMEDIATELY!

IMPORTANT - In case of internal contact **DO NOT** give fluids that would induce vomiting.

Eye contact: Flush with water for at least 15 minutes and **GET MEDICAL ATTENTION IMMEDIATELY!**

⚠ WARNING: Explosive gases are vented from a battery when being charged or discharged which could explode if exposed to a flame or spark.

SET-UP ALL UNITS

1. Lay out hardware according to the "Where Used" list in the List of Hardware Package Contents.
2. Install handle assembly to handle mounting frame using four 3/8-16 x 1" bolts, flat washers, and elastic stop nuts. Three different handle heights can be obtained using one of the three slotted holes in the handle mounting frame.
3. Route the throttle control above the jackshaft and up the right side of handle. Secure to handle with 1/4-20 x 2" hex head bolt and elastic stop nut. Secure cable about half way down the handle using a cable tie.

NOTE: *Check that the throttle cable moves the carburetor controls through their full range including choke. If not, adjust as required.*

ASSEMBLY INSTRUCTIONS cont'd

4. Route the safety interlock wires up the left handle tube and attach the connector to the switch as shown. Be certain that the connector does not hit the safety lever stop tab, if it does, rotate the switch to the position shown (See fig. 1).

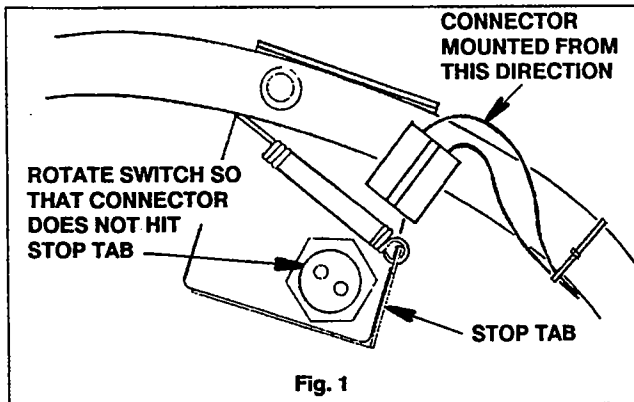

5. Installing steering control rods.
- With steering control lever located in neutral lock position, insert control rod through loop under control lever. Do not secure with hairpin at this time.
 - Thread swivel joint onto control rod until end of swivel joint is centered in slot on bellcrank. (See fig. 2)

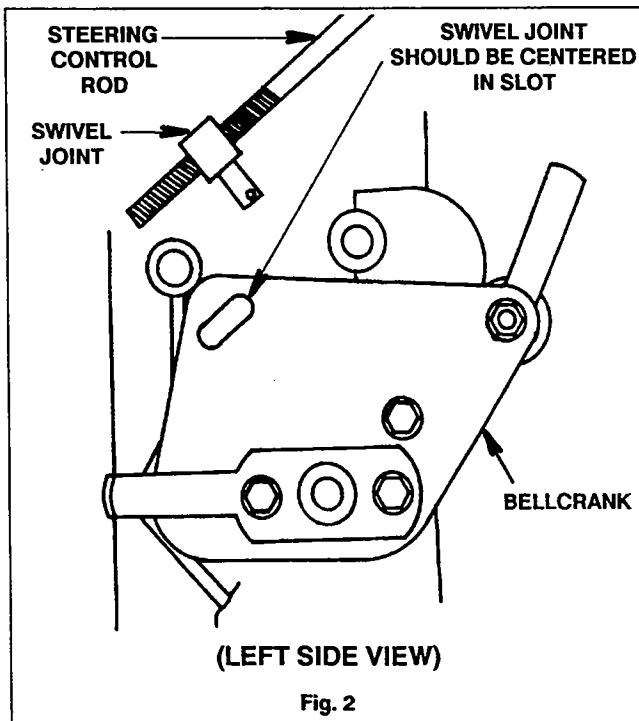

- Remove control rod without moving the swivel joint.
- Hook speed control spring on end of swivel joint. Add flat washer and insert through bellcrank. Add another flat washer and secure with hairpin.

- e) Release steering control lever from neutral lock position. Insert control rod through loop under control lever. Secure with hairpin. Neutral was adjusted at the factory, if the machine needs to be adjusted, go to the adjustment section of this manual.

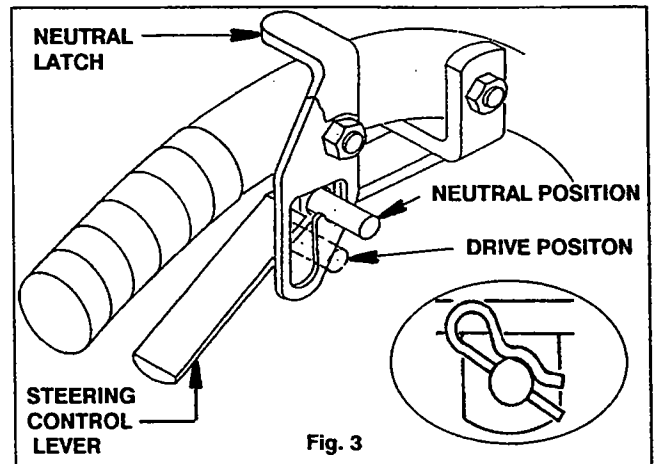

6. Installing speed control rod.
- Thread swivel joint onto speed control rod.
 - Push speed control bellcrank forward so that it is activating the neutral safety switch. Insert end of swivel joint through hole in bellcrank and secure with hairpin (See fig. 4).

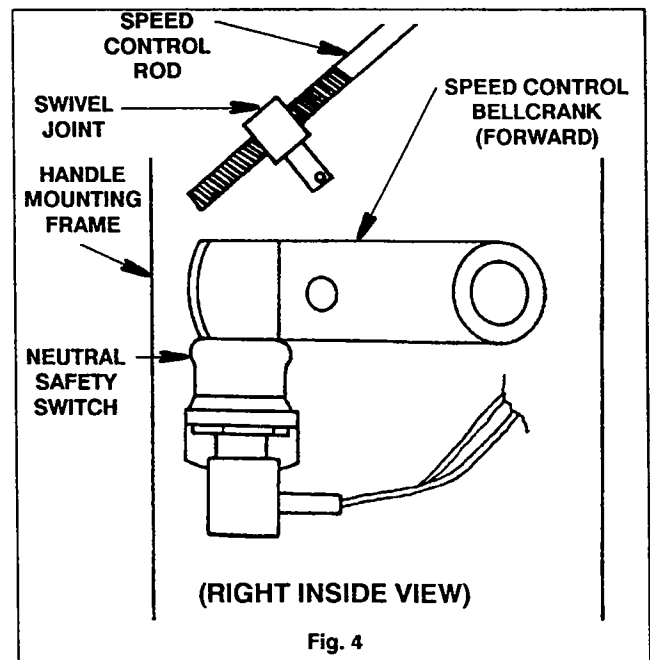

- With speed adjustment lever in neutral position, rotate control rod until end of rod is slightly behind hole in speed adjustment lever. Insert through hole and secure with hairpin.

ASSEMBLY cont'd

7. Attach fuel tank (See fig. 5) as follows:
 - a) Wrap the straps around the fuel tank to pre-form them, then set aside to be used later.
 - b) Fuel tank support pads were glued to the handle mounting frame at the factory. These must align with the tank strap grooves when the tank is sitting in the oval cutout of the handle mounting frame. If they are not aligned, then reposition them at this time.
 - c) Two pads are shipped separately with tank and must be positioned on top of the fuel tank in the strap grooves.
 - d) Position the tank so the SCAG logo is forward. Place the straps around the tank going under the handle mounting frame, secure the strap together in front using two 1/4-20 x 2" slotted machine screws and hex nuts. Tighten screws until the tank will not slide around. Over tightening will damage the tank or straps.
 - e) Attach the fuel line to the valve on the bottom of the tank.

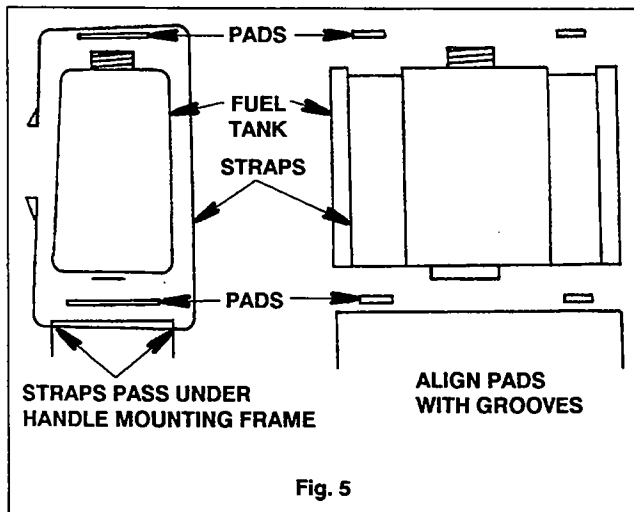

8. Check engine oil level, add as necessary (unit was filled with 30 weight detergent oil at factory).
9. Check hydrostatic oil reservoir. Oil level should be 3" from top of reservoir (not top of filler neck). **DO NOT OVERFILL !!!** Add 30 weight detergent oil if necessary.
10. Fill fuel tank with gasoline and then open shut-off valve under tank.

ATTACHING 52", 61", OR 72" CUTTER DECKS

1. Before beginning, determine which mounting holes are to be used to best suit the cutting height requirements of your customer. High/Medium/Low ranges (See fig. 6).
2. Remove belt cover by loosening the wing nuts securing it to the cutter deck.
3. Position the cutter deck so that the engine deck is between the mounting brackets of the cutter deck. Install two bolts through the mounting holes selected, secure loosely with a flat washer, lock washer and hex nut. Tilt the engine deck up or down to align the remaining four holes and secure with remaining hardware.

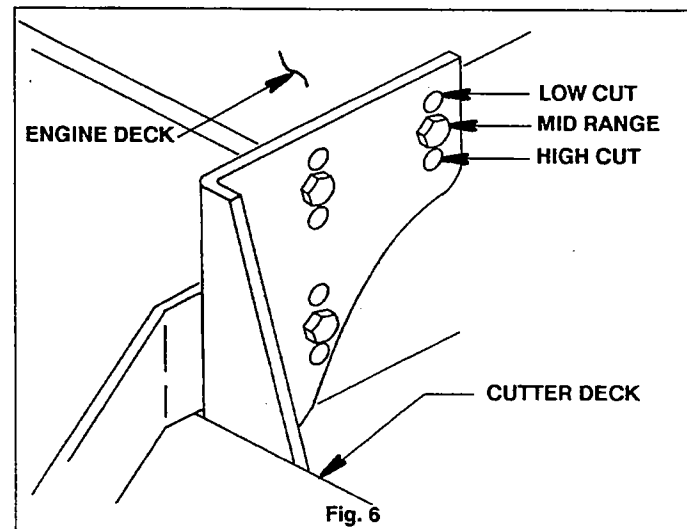

4. Torque cutter deck mounting bolts to 50 to 70 ft. lbs..
5. Route belt around engine pulley. Connect lower blade clutch control rod to eyebolt and over-center link with flat washer and hair pin.
6. Attach discharge chute to cutter deck using two 5/16-18 x 1" bolt and elastic stop nuts.
7. Attach caster wheels supports to cutter deck using four 5/16-18 x 3/4" bolts, lock washers and hex nuts.

NOTE: Check all hardware to be sure it is tightened properly, also check clearance and routing of drive belts.

ADJUSTMENTS

CUTTER DECK DRIVE ADJUSTMENTS

1. Engage blade clutch lever and check for proper over center clearance. There should be about 3/8" between rod and straight edge (see fig. 7). Bend the stop tab to adjust clearance.

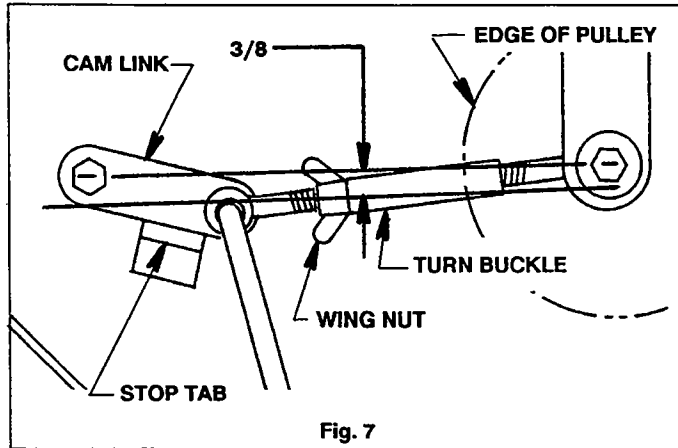

Fig. 7

2. Adjust belt tension so that the belt moves 1/2" with 10 lbs. of pressure applied between the center and left spindle pulleys (see fig. 8). Adjustment is made by loosening the wing nut and tightening/loosening the turn buckle (see fig. 7). Belt driving right spindle should be checked the same way. Adjust with J-rod on RH belt tension adjustment idler.

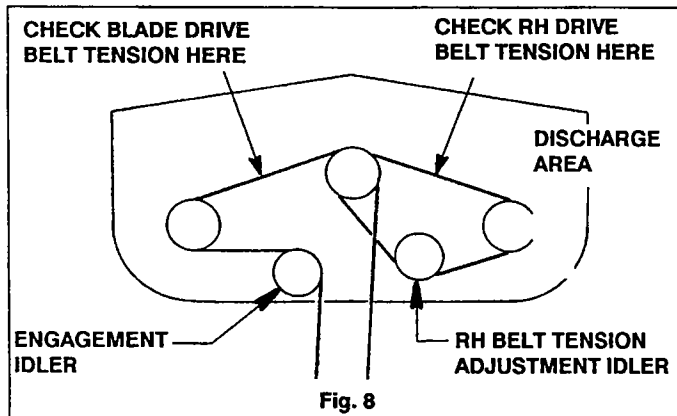

Fig. 8

CUTTER DECK ADJUSTMENTS

Due to the many conditions that exist it is difficult to suggest a setting that will work for every lawn. There are two adjustments that can be made on these decks, pitch and height.

PITCH is the angle of the blades (comparing front to rear). A *positive pitch* is when the front (leading) edge of the cutting plane is lower than the rear (trailing) edge, *level pitch* is when both front and rear are the same height, a *negative pitch* is when the leading edge is higher than the rear edge.

HEIGHT is the nominal distance the blade is off of the ground. This measurement is made with the blades pointed side to side and distance is measured between cutting tip and ground.

Adjusting the blade height can be done by moving any number of the five spacers on the blade mounting bolts to the top of the spindle shaft or below the spindle shaft (all blades should be positioned equally). Unit is shipped with one spacer on top and four underneath (see fig. 9). For best cut and discharge a minimum of three spacer should be between the blade and spindle.

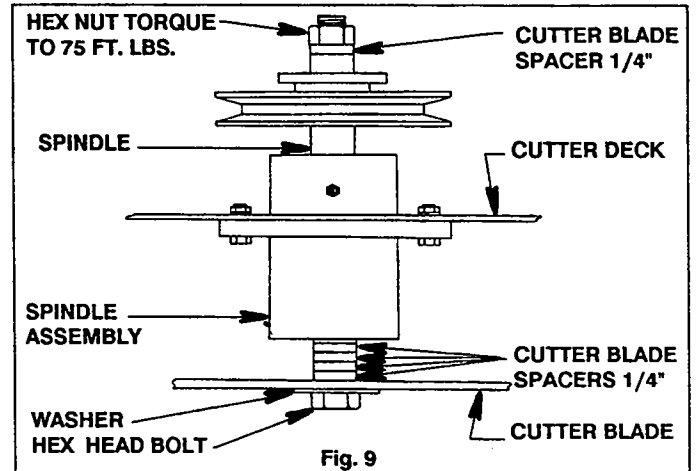

Fig. 9

Additional range to the cutting height can be achieved by repositioning the cutter deck in relationship to the engine deck (This adjustment can also effect the pitch of the deck). There are 3 positions (see fig. 6), suggested mounting is the middle holes. For cutting lower, mount the deck in the top holes. To cut higher, mount the deck in the bottom holes.

Remember to check the cutter deck belt alignment. Shim- ming or attaching the idler mounting bracket from under- neath may be necessary to maintain belt life.

Caster spacers also can be repositioned to change cutting heights and to change the pitch of the deck (see fig. 10).

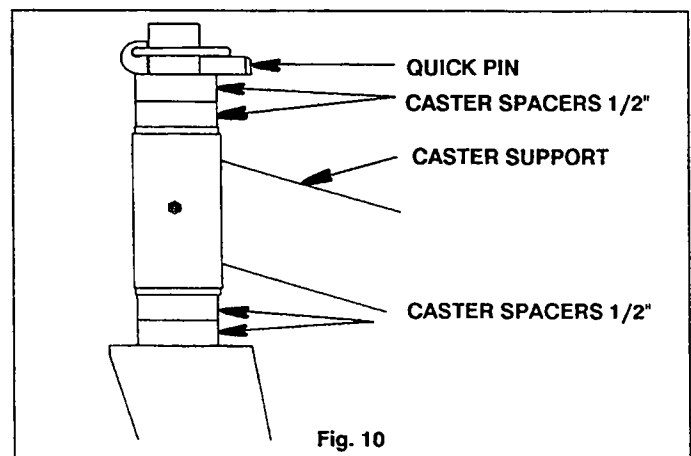

Fig. 10

ADJUSTMENTS Cont'd

STEERING CONTROL NEUTRAL ADJUSTMENT

NOTE: If hydraulic components (pumps, motors, hose, etc.) are replaced, all air must be bled from system prior to making neutral adjustment.

1. Locate machine in a secure area, away from bystanders, and preferably facing a wall. Raise drive wheels off ground. Block caster wheels.
2. Disconnect steering control rod from handle grip and also disconnect swivel joint and speed control spring from control bellcrank (see fig. 11).

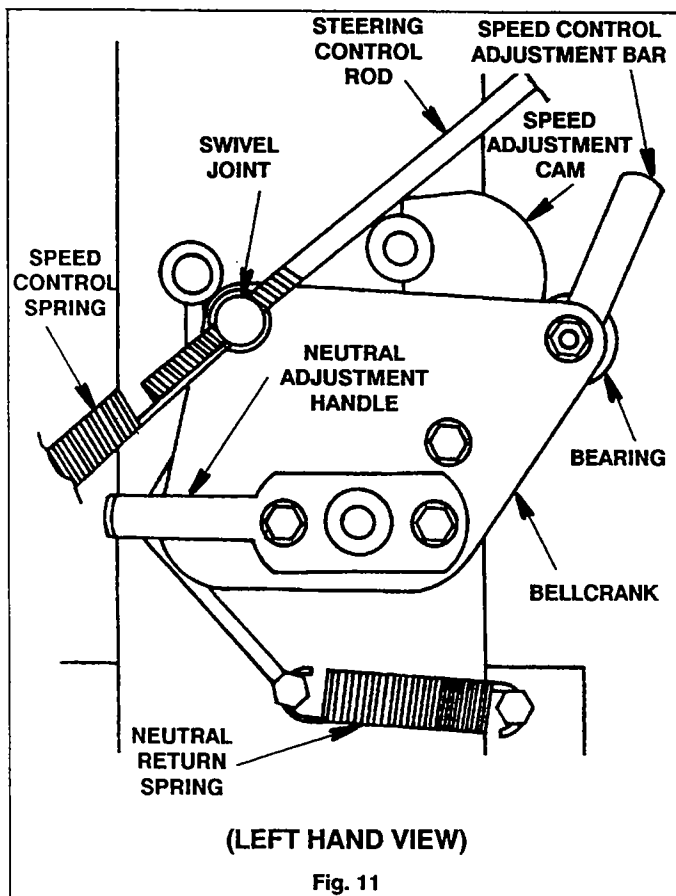

3. Loosen bolts on neutral adjustment handle and speed control adjustment bar.

4. Start engine. Disconnect operator presence switch or have someone hold control, so that machine will stay running while adjustments are made.
5. Move adjustment handle to position where wheels stop forward motion and then move to where wheels stop reverse motion. Locate handle in a position half way in between these two positions and tighten bolts.
6. Insert steering control rod in loop under steering lever. Adjust swivel joint so it is positioned in **middle** of slot in bellcrank (See fig. 2).
7. Remove control rod from steering lever and reconnect speed control spring and swivel joint to bellcrank. Reconnect steering control rod to steering lever.
8. Position speed control adjustment bar so that bearing is just touching the speed adjustment cam. Tighten bolts. **Also reconnect the operator presence safety switch.**

SPEED CONTROL NEUTRAL ADJUSTMENT

1. Shift speed adjustment lever to neutral (position closest to operator).
2. Loosen nut on speed control adjustment bar and position bar, so that the bearing is just touching the speed adjustment cam (see fig. 11). Tighten nut.

HYDRAULIC PUMP DRIVE BELT

The hydraulic pump drive belt is spring loaded and does not require tensioning.

TIRE PRESSURES

| | |
|-------------------|--------|
| Drive Wheel Tires | 15 PSI |
| Caster Wheels | 25 PSI |

INITIAL RUN-IN

⚠ WARNING: Use extreme caution during mower's initial run-in to assure caster wheels are adequately blocked and drive wheels do not inadvertently contact ground. Keep bystanders away from machine. Never allow mower to discharge towards someone. Never leave the machine unattended during the initial run-in.

1. Lubricate all fittings as specified in Lubrication chart.
2. Locate machine in a secure area, away from bystanders, and preferably facing a wall. Raise drive wheels off ground. Block caster wheels.
3. Start engine and shift speed adjustment lever to mid range. Engage cutter blades. Set throttle for 3/4 of full engine rpm.
4. Run the machine for a few minutes.
5. Declutch cutter blades, shift speed adjustment lever into NEUTRAL, Stop engine.
6. Check tension of blade drive belt(s) and transmission drive belt. Adjust if necessary.
7. If necessary, readjust steering control neutral and speed control adjustment neutral as indicated in the Adjustments Section.
8. Check function of all safety interlocks. Make sure that engine will not start unless transmission is in neutral and blade clutch is disengaged.
9. Check tire pressure and adjust to:

| | |
|---------------|---------|
| Caster Wheels | 25 psi. |
| Drive Wheels | 15 psi. |

OPERATING INSTRUCTIONS

1. Read and understand the instructions on safety before attempting to operate.
 2. Before starting engine:
 - * Fuel valve must be opened.
 - * Speed control lever must be in NEUTRAL.
 - * Blade clutch lever must be in STOP position.
 - * Neutral latches must be in NEUTRAL LOCK position.
 - * Key switch on.
 - * Choke as required.
 3. Start Engine. Adjust throttle.
 4. Engage cutter blades by pushing blade clutch lever forward until it snaps into the ON position. Pull lever back to disengage cutter blades.
 5. While squeezing steering control levers with both hands, release both neutral latches.
 6. When steering control levers are released, machine will travel straight. To make a right turn, squeeze RH lever to turn left squeeze LH lever.
 7. Shift speed control lever for desired mowing speed.
- NOTE:** *Top speed is suggested only for transport!*
8. TO STOP wheel drive, shift speed control lever into neutral, squeeze both steering levers, lock neutral latches.
 9. For reverse, pull up on the steering control levers.

MAINTENANCE

AIR BLEED PROCEDURE

Air must be bled from hydraulic system when any of the hydraulic drive components are removed and when hydrostatic oil is changed.

1. With oil in reservoir, disconnect hose line from each pump to oil filter (top port) at the pumps.
2. When oil starts to flow from disconnected hose line (about 20 seconds), plug hose lines.
3. Watch for oil to drip at a steady rate from open ports on pumps. When this happens, unplug hose lines and reconnect to ports.
4. Secure machine in a secure area, away from bystanders, and preferably facing a wall. Raise drive wheels off ground. Block caster wheels.
5. Run machine at full forward speed for approximately 30 seconds and then run in reverse for approximately 30 seconds.
6. If neutral needs to be adjusted, follow procedure in adjustments section of this manual.

FREEWHEEL POSITION

To move machine around without having the engine running, rotate dump valve levers located on the left hand side of the pump approximately 1/2 turn. Levers must be returned to original position in order to operate machine.

CUTTER BLADES

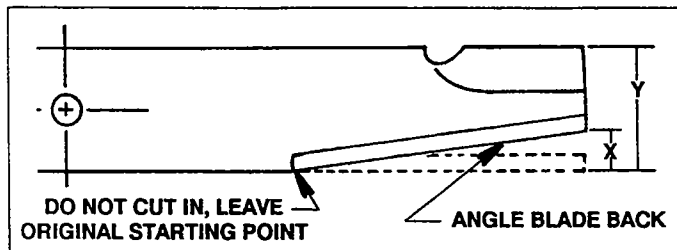

Do not sharpen (X) beyond 1/3 of the width (Y) of the blade.

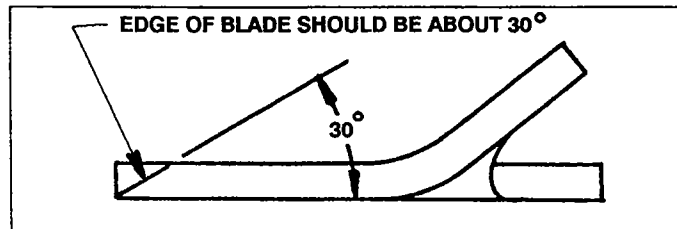

Suggestion: Dress the blade with a file. Using a wheel grinder may burn the blade.

LUBRICATION & MAINTENANCE

| BREAK-IN | | | PROCEDURE | COMMENTS |
|----------|---|---|---|--|
| X | X | X | Check all hardware for proper tightness Change engine oil and filter at 5 hours Change hydrostatic oil filter at 20 hours | Adjust oil level as needed - 30W detergent |
| X | X | X | Check engine oil Remove debris from under belt cover Sharpen cutter blades Clean air filter Clean blower screen Grease spindle bearings 2 pumps of hand gun | Do not over fill MORE OFTEN IF NEEDED " " " " " " " " " US Lithium MP White Grease 2125 |
| X | X | X | Check battery acid level Check tire pressure | Distilled water only Add or adjust as required |
| X | X | X | Replace air filter Change engine oil Grease caster wheel bearings Grease caster wheel pivots Grease idler arm pivots | MORE OFTEN IF NEEDED " " " Chassis grease Chassis grease Chassis grease |
| X | X | X | Drain Hydraulic System and replace fluid Change hydrostatic oil filter Check all hardware for proper tightness Change engine oil filter Check hydrostatic fluid reservoir level Clean and adjust spark plugs | Use 30W detergent motor oil Clean area before removing filter See engine mfg. information See engine mfg. information |

- * Depending on climate and environment, lubrication may be required every 8 to 40 hours.
- * Do not over grease as this may damage seal.

52, 61, & 72" CUTTER DECK

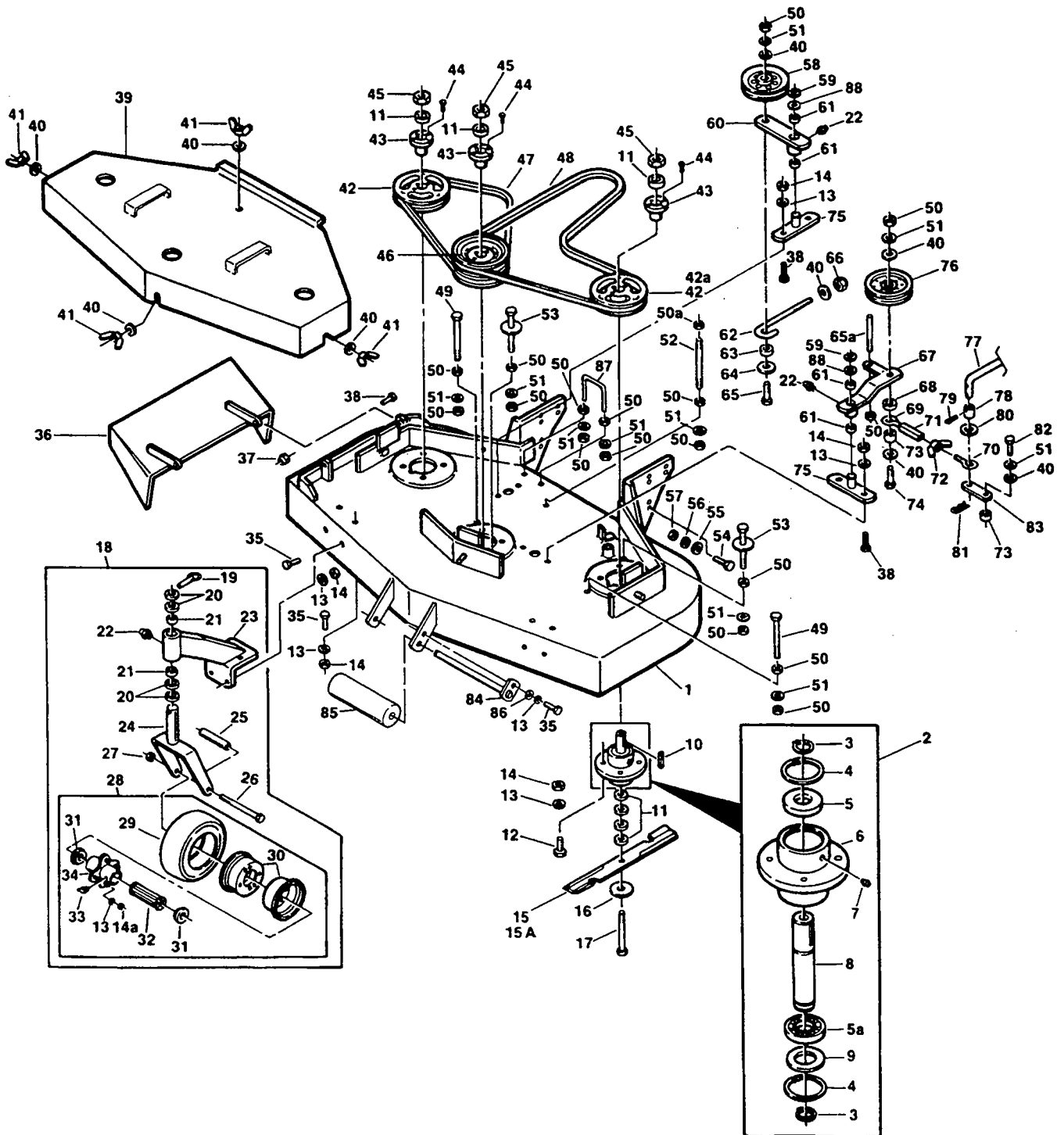

52, 61, & 72" CUTTER DECKS

| Ref. No. | Part No. | Description | SWM | | | Ref. No. | Part No. | Description | SWM | | |
|----------|----------|-----------------------------------|-----|----|----|----------|----------|-------------------------------------|-----|----|----|
| | | | 52 | 61 | 72 | | | | 52 | 61 | 72 |
| 1 | 46163 | Cutter Deck (incl. decal) | x | | | 43 | 48141 | Tapered Hub | x | x | x |
| 1 | 46119 | Cutter Deck (incl. decal) | | x | | 44 | * | Hex Hd. Bolt 1/4-20 x 3/4 | x | x | x |
| 1 | 46194 | Cutter Deck (incl. decal) | | | x | 45 | * | Hex Nut, 5/8-11 | x | x | x |
| 2 | 46020 | Cutter Spindle Assy. (incl. 3-9) | x | x | x | 46 | 48412 | Pulley, Double (incl. 43-44) | x | x | |
| 3 | 04050-04 | Retaining Ring, 1" Ext.-Inverted | x | x | x | 46 | 48302 | Pulley, Double (incl. 43-44) | | | x |
| 4 | 04050-07 | Retaining Ring, 2-7/16" Int.basic | x | x | x | 47 | 48285 | Belt, RH Blade Drive | x | | |
| 5 | 48101-01 | Bearing, Cutter Spindle upper | x | x | x | 47 | 48265 | Belt, RH Blade Drive | | x | |
| 5a | 48101-02 | Bearing, Cutter Spindle lower | x | x | x | 47 | 48295 | Belt, RH Blade Drive | | | x |
| 6 | 41001 | Spindle Housing | x | x | x | 48 | 48286 | Belt, Blade Drive | x | | |
| 7 | 48114-02 | Grease Fitting Str. 5/16 Serr. | x | x | x | 48 | 48264 | Belt, Blade Drive | | | x |
| 8 | 43001-02 | Spindle, Cutter Blade | x | x | x | 48 | 48296 | Belt, Blade Drive | | | x |
| 9 | 04041-02 | Washer, 1-5/16 x 2-7/16 x 16 ga. | x | x | x | 49 | * | Hex Hd. Bolt, 3/8-16 x 5" | x | x | x |
| 10 | 04063-08 | Key, 1/4 x 1/4 x 2 | x | x | x | 50 | * | Hex Nut, 3/8-16 | x | x | x |
| 11 | 43038 | Spacer, Cutter Blade | x | x | x | 50a | * | Hex Nut, 3/8-16, Centerlock | x | x | x |
| 12 | * | Hex Hd. Bolt, 5/16-18 x 1-1/4 | x | x | x | 51 | * | Lockwasher, Spring, 3/8 | x | x | x |
| 13 | * | Lockwasher, Spring, 5/16 | x | x | x | 52 | 04004-02 | Support, Belt Cover | x | x | x |
| 14 | * | Hex Nut, 5/16-18 | x | x | x | 53 | 45098 | Belt Guide | x | x | x |
| 14a | * | Hex Nut, 5/16-24 | x | x | x | 54 | * | Hex Hd. Bolt, 7/16-14 x 1-1/2 | x | x | x |
| 15 | 48108 | Cutter Blade 18" | x | | | 55 | * | Washer, 15/32 x 59/64 x 16 ga. | x | x | x |
| 15 | 48111 | Cutter Blade 21" | | x | | 56 | * | Lock Washer, Spring, 7/16 | x | x | x |
| 15 | 48112 | Cutter Blade 24" | | | x | 57 | * | Hex Nut, 7/16-14 | x | x | x |
| 15a | 48185 | Cutter Blade 18" Hi Lift | x | | | 58 | 48181 | Idler Pulley, "V" Groove | x | x | x |
| 16 | 04040-10 | Flat Washer, 5/8" W | x | x | x | 59 | 04050-02 | Retaining Ring, 3/4" Ext."E" | x | x | x |
| 17 | 04001-41 | Hex Hd. Bolt, 5/8-11 x 9-1/2" | x | x | x | 60 | 46081 | Idler Arm Assy. (incl. 22 & 61) | x | x | x |
| 18 | 46079 | Caster Assy, Comp. (incl. 19-28) | x | x | x | 61 | 48100-05 | Bronze Bearing | x | x | x |
| 19 | 04066-01 | Quick Pin | x | x | x | 62 | 43028 | J Rod, Idler Pull | x | x | x |
| 20 | 43037-01 | Spacer, Caster Yoke, 1/2" thick | x | x | x | 63 | 43077 | Spacer, J Pull Rod | x | x | x |
| 21 | 48100-01 | Bronze Bearing | x | x | x | 64 | 04041-12 | Washer, 3/8 x 1-1/2 x 16 ga. | x | x | x |
| 22 | 48114-01 | Grease Fitting, Str., 1/4-28 | x | x | x | 65 | * | Hex Hd Bolt, 3/8-16 x 2-1/4 | x | x | x |
| 23 | 46082 | Support Assy. (incl. 21-22) | x | x | x | 65a | 04004-04 | Stud | x | x | x |
| 24 | 45006 | Caster Yoke | x | x | x | 66 | * | Hex Nut, 3/8-16 Elastic Stop | x | x | x |
| 25 | 43022 | Sleeve, Caster Wheel Bearing | x | x | x | 67 | 46145 | Idler Arm (incl. 22 & 61) | x | x | x |
| 26 | 04001-37 | Hex Hd Bolt, 1/2-13 x 5-1/2" | x | x | x | 68 | 43063 | Spacer | x | x | x |
| 27 | * | Hex Locknut, 1/2-13 | x | x | x | 69 | 04070-02 | Eyebolt, LH | x | x | x |
| 28 | 48307-01 | Wheel Assy. (incl. 13-14, 29-34) | x | x | x | 70 | 04070-01 | Eyebolt, RH | x | x | x |
| 29 | 48307-02 | Tire only, Caster Wheel | x | x | x | 71 | 43025 | Turnbuckle | x | x | x |
| | 48006-03 | Inner Tube only, Caster Wheel | x | x | x | 72 | 04022-02 | Wing Nut, 5/16-18 | x | x | x |
| 30 | 48307-04 | Rim Pair, Caster Wheel | x | x | x | 73 | 43042 | Sleeve, Cam Clutch | x | x | x |
| 31 | 48006-07 | Retainer, Bearing, Caster Wheel | x | x | x | 74 | * | Hex Hd Bolt, 3/8-16 x 2-3/4 | x | x | x |
| 32 | 48006-06 | Roller Bearing, Caster Wheel | x | x | x | 75 | 45037 | Idler Pivot | x | x | x |
| 33 | 48114-03 | Grease Fitting 45' 1/4-28 | x | x | x | 76 | 48269 | Idler Pulley, Belt Clutch | x | x | x |
| 34 | 48006-05 | Hub Assy. (incl. bolts) | x | x | x | 77 | 44003 | Blade Clutch Rod, Lower | x | x | x |
| 35 | * | Hex Hd. Bolt, 5/16-18 x 3/4" | x | x | x | 78 | 43043 | Sleeve, Clutch Rod | x | x | x |
| 36 | 45029 | Discharge Chute | | x | x | 79 | * | Cotter Pin, 3/32 x 1 | x | x | x |
| 36 | 45100 | Discharge Chute | x | | | 80 | * | Washer, 33/64 x 1 x 16 ga. | x | x | x |
| 37 | * | Hex Nut, 5/16-18 Elastic Stop | x | x | x | 81 | 04062-01 | Hair Pin Large | x | x | x |
| 38 | * | Hex Hd. Bolt, 5/16-18 x 1 | x | x | x | 82 | * | Hex Hd Bolt, 3/8-16 x 1 | x | x | x |
| 39 | 46164 | Belt Cover (incl. decals) | x | | | 83 | 42057 | Cam Link | x | x | x |
| 39 | 46121 | Belt Cover (incl. decals) | | x | | 84 | 45046 | Roller Shaft | x | x | x |
| 39 | 46194 | Belt Cover (incl. decals) | | | x | 85 | 48038 | Guide Roller | x | x | x |
| 40 | * | Washer 25/64 x 15/16 x 12 ga. | x | x | x | 86 | * | Flat Washer, 11/32 x 11/16 x 16 ga. | x | x | x |
| 41 | 04022-04 | Wing Nut, 3/8-16 | x | x | x | 87 | 44008 | Belt Guide | x | x | x |
| 42 | 48127 | Pulley (incl. 43-44) | x | x | x | 88 | * | Flat washer, 3/4 x 1-1/4 x .035 | x | x | x |
| 42a | 48299 | Pulley (incl. 43-44) | | | x | | | | | | |

* Common hardware which should be purchased locally. All bolt Grade 5 plated, all other fasteners zinc plated.

ENGINE DECK

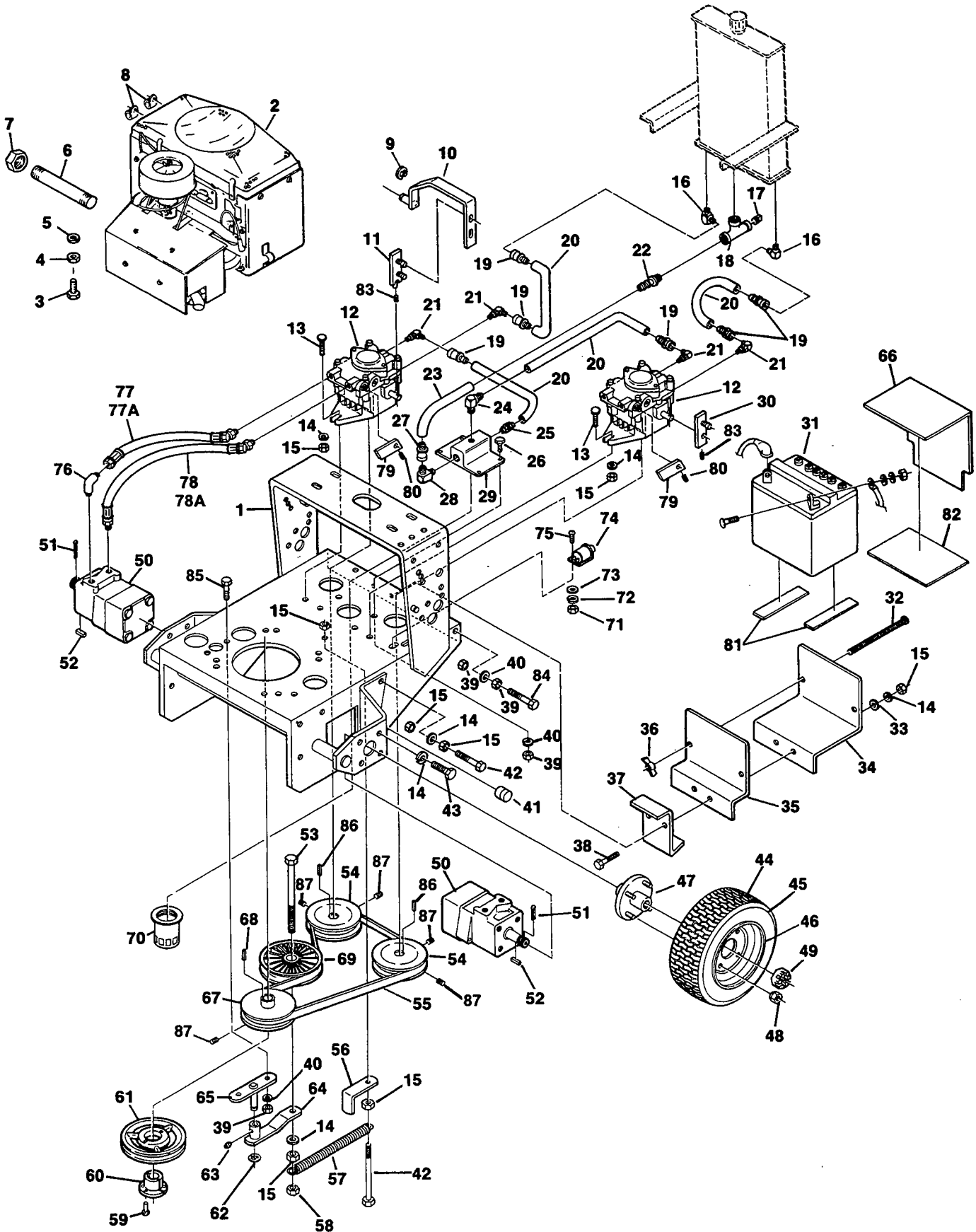

ENGINE DECK

| Ref. No. | Part No. | Description | 14KA | 14KH | 18KH | 20EKH |
|----------|----------|---|------|------|------|-------|
| 1 | 45270 | Engine Deck | X | X | X | X |
| 2a | 48528 | Engine 14H Kawasaki | X | | | |
| 2a | 48357 | Engine 14HP Kohler | | X | | |
| 2b | 48268 | Engine 18HP Kohler (MV18 PS-58511) | | | X | |
| 2b | 48358 | Engine 20HP Kohler El. St. (MV20 PS-57508) | | | | X |
| 3 | * | Bolt, Hex Hd. Metric 8 x 30 | X | X | | |
| 3 | * | Hex Hd. Bolt, 5/16-18 x 1-3/4 | | | X | X |
| 3 | * | Bolt, Hex Hd., 5/16-18 x 1-1/4 | | | X | X |
| 4 | * | Hex Nut, 5/16-18 Elastic Stop | | | X | X |
| 5 | * | Lockwasher, 5/16 Spring | X | X | X | X |
| 6 | 48431 | Pipe, 4.75" Nipple | | | X | X |
| 7 | 48257 | Pipe Cap | | | X | X |
| 8 | 48059-01 | Fuel Hose Clamp | X | X | X | X |
| 9 | 04050-10 | Retaining Ring, 1/2 "E" | X | X | X | X |
| 10 | 45283 | Shaft Widmt. - RH Pump Control | X | X | X | X |
| 11 | 46324 | Lever Assembly, Pump Control - RH | X | X | X | X |
| 12 | 48436 | Pump, Sunstrand BDP-10L100 | X | X | X | X |
| 13 | * | Bolt, Carriage, 3/8-16 x 1-1/4 | X | X | X | X |
| 14 | * | Lockwasher, 3/8 | X | X | X | X |
| 15 | * | Hex Nut, 3/8-16 | X | X | X | X |
| 16 | 48484-01 | Elbow, 90 deg. Female 1/4 NPT to 1/4 JIC Male | X | X | X | X |
| 17 | 48117 | Plug, 3/8 NPT | X | X | X | X |
| 18 | 48491 | Tee, Galvanized 3/8 NPT | X | X | X | X |
| 19 | 48353-02 | Coupling, 7/16-20 SAE Flare Swivel to 1/4" Hose Push On | X | X | X | X |
| 20 | 48482-03 | Hose, 1/4" ID, 8" Long | X | X | X | X |
| 21 | 48350-03 | Elbow, 90 deg. 7/16-20 JIC to 7/16-20 "O" Ring | X | X | X | X |
| 22 | 48352-03 | Coupling, 3/8 Straight Male NPT to 1/2" Hose Push On | X | X | X | X |
| 23 | 48351-05 | Hose, 1/2" ID, 9" Long | X | X | X | X |
| 24 | 48486-01 | Elbow, 90 deg. Male 1/4 NPT to 1/4" Hose Push On | X | X | X | X |
| 25 | 48352-02 | Coupling, 1/4 Straight Male NPT to 1/4" Hose Push On | X | X | X | X |
| 26 | * | Bolt, Hex Hd., 5/16-18 x 2-1/2 | X | X | X | X |
| 27 | 48353-01 | Coupling, 3/4-16 SAE Flare Swivel to 1/2" Hose Push On | X | X | X | X |
| 28 | 48489-02 | Elbow, 90 deg. Male 3/4-16 JIC to 1/2" Male NPT | X | X | X | X |
| 29 | 48471 | Oil Filter Assembly (Includes item 70) | X | X | X | X |
| 30 | 46323 | Lever Assembly, Pump Control - LH | X | X | X | X |
| 31 | 48015 | Battery | | | | X |
| 32 | * | Carriage Hd. Bolt, 1/4-20 x 6 | X | X | X | X |
| 33 | * | Flatwasher, 3/8 | X | X | X | X |
| 34 | 45302 | Battery Box | | | | X |
| 35 | 42745 | Battery Clamp | | | | X |
| 36 | 04022-01 | Wing Nut, 1/4-20 Elastic Stop | X | X | X | X |
| 37 | 45125 | Sulky Mounting Bracket (Included with Riding Sulky) | | | | X |
| 38 | * | Bolt, Hex Hd., 3/8-16 x 1-1/4 | X | X | X | X |
| 39 | * | Hex Nut, 5/16-18 | X | X | X | X |
| 40 | * | Lockwasher, 5/16 | X | X | X | X |
| 41 | 48534 | Cover, Sulky Mount | X | X | X | X |
| 42 | * | Bolt, Hex Hd., 3/8-16 x 2-3/4 | X | X | X | X |
| 43 | * | Bolt, Hex Hd., 3/8-16 x 1 | X | X | X | X |
| 44 | 48468 | Wheel Assembly (Incl. 45, 46, 47, 48) | X | X | X | X |
| 45 | 48004-02 | Tire, 16 x 6.50, 2 ply | X | X | X | X |
| 46 | 48004-04 | Rim Assembly | X | X | X | X |
| 47 | 48468-05 | Wheel Hub (Includes item 48) | X | X | X | X |
| 48 | 48004-06 | Bolt and Nut | X | X | X | X |
| 49 | 04027-02 | Hex Castle Nut, 3/4-28 UNEF | X | X | X | X |
| 50 | 48437 | Motor, White RS | X | X | X | X |
| 51 | * | Cotter Pin, 3/32 x 1-1/4 | X | X | X | X |
| 52 | 04063-15 | Key, 3/16 x 3/16 x .75 | X | X | X | X |
| 53 | * | Bolt, Hex Hd., 3/8-16 x 2-1/4 | X | X | X | X |
| 54 | 48470 | Pulley, Pump Shaft | X | X | X | X |

* Common hardware which should be purchased locally. All bolts Grade 5 plated, all other fasteners zinc plated.

ENGINE DECK CONTINUED ON FOLLOWING PAGE

ENGINE DECK CONT'D

See Page 12 For Illustration

| Ref. No. | Part No. | Description | 14KA | 14KH | 18KH | 20EKH |
|----------|----------|---|------|------|------|-------|
| 55 | 48472 | Belt, Pump Drive | X | X | X | X |
| 56 | 42692 | Belt Guide, Cutter - Rear | X | X | X | X |
| 57 | 48051 | Spring, Pump Belt Idler | X | X | X | X |
| 58 | * | Hex Nut, Elastic Stop Lock, 3/8-16 | X | X | X | X |
| 59 | * | Bolt, Hex Hd., 1/4-20 x 3/4 | X | X | X | X |
| 60 | 48141 | Taper Hub (for 48127) | X | X | X | |
| 60 | 48378-03 | Taper Hub (for 48378) | | | | X |
| 61 | 48127 | Pulley, Cutter Drive | X | X | X | |
| 61 | 48378 | Pulley, Cutter Drive | | | | X |
| 62 | 04050-02 | Retaining Ring, 3/4 Ext. - "E" | X | X | X | X |
| 63 | 48114-01 | Grease Fitting | X | X | X | X |
| 64 | 46340 | Idler Arm, Traction Belt (Includes bushings and grease fitting) | X | X | X | X |
| 65 | 45212 | Pivot, Idler Arm | X | X | X | X |
| 66 | 42761 | Battery Cover | | | | X |
| 67 | 48422 | Pulley, Pump Drive | X | X | X | |
| 67 | 48423 | Pulley, Pump Drive | | | | X |
| 68 | 04063-03 | Key, 1/4 x 1/4 x 2-1/2 | X | X | X | X |
| 69 | 48473 | Pulley, Idler - Pump Drive | X | X | X | X |
| 70 | 48471-01 | Oil Filter | X | X | X | X |
| 71 | * | Hex Nut, #10-32 | X | X | X | X |
| 72 | * | Lockwasher, #10 Ext. Tooth | X | X | X | X |
| 73 | * | Washer (.219 x .500 x .049) | X | X | X | X |
| 74 | 48305 | Switch, Clutch Safety (black) | X | X | X | X |
| 75 | * | Phillips Hd. Machine Screw, 10-32 x 1/2 | X | X | X | X |
| 76 | 48485-02 | Elbow, 45 deg. Male 7/8-14 JIC to Male 7/8-14 "O" Ring | X | X | X | X |
| 77 | 48475 | Hose, Pump to Motor, LH - Forward | X | X | X | X |
| 77A | 48477 | Hose, Pump to Motor, RH - Forward | X | X | X | X |
| 78 | 48476 | Hose, Pump to Motor, LH - Reverse | X | X | X | X |
| 78A | 48478 | Hose, Pump to Motor, RH - Reverse | X | X | X | X |
| 79 | 48526 | Lever, Dump Valve | X | X | X | X |
| 80 | * | Setscrew, #8-32 x 3/4 Socket Hd. | X | X | X | X |
| 81 | 48205 | Pad, Rubber | | | | X |
| 82 | 48099 | Pad, Battery Cover | | | | X |
| 83 | 04015-02 | Setscrew, #10-32 x 3/4 Socket Hd. | X | X | X | X |
| 84 | * | Bolt, Hex Hd., 5/16-18 x 1-1/2 | X | X | X | X |
| 85 | * | Bolt, Hex Hd., 5/16-18 x 1 | X | X | X | X |
| 86 | 04063-14 | Key, 5.0 x 5.0 x 25mm | X | X | X | X |
| 87 | 04012-03 | Setscrew, 5/16-18 x 1/4 Socket Hd. | X | X | X | X |
| NS | 43096 | Spacer, Oil Filter | X | X | X | X |

* Common hardware which should be purchased locally. All bolts Grade 5 plated, all other fasteners zinc plated.

REPLACEMENT DECALS



48314
Decal - Scag's Logo
(Located On Cutter Deck Cover - Top Surface)

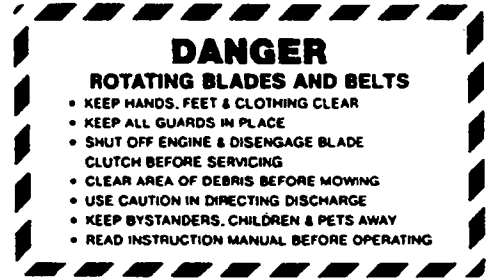

48073
Decal - Danger, Rotating Blades
(Located On Cutter Deck Cover - Near Discharge Chute)



48072
Decal - Heavy Duty Commercial
(Located On Cutter Deck Cover - Front Wall)

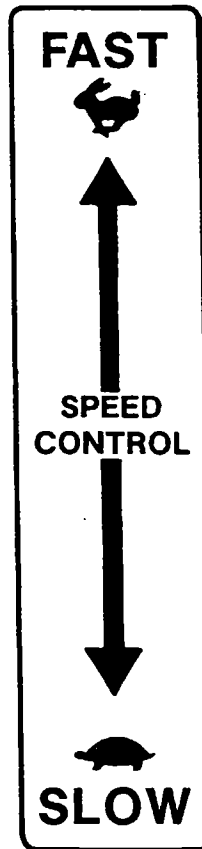

48524
Decal - Speed Control
(Located On Shift Quadrant)

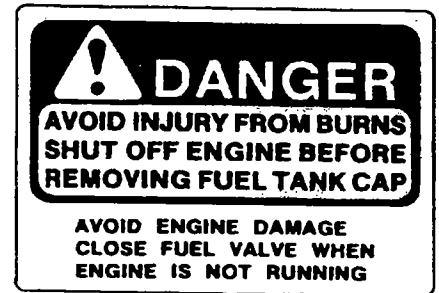

48281
Decal - Operator Warning Fuel Fill
(Located On Top of Fuel Tank)

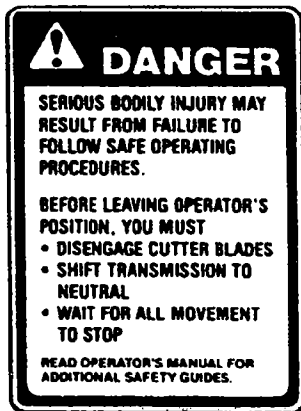

48222
Decal - Operator Warning
(Located On Back Of Fuel Tank)



48071
Decal - O.P.E.I. Safety
(Located On Cutter Deck Near Discharge Chute)



72 48327
61 48320
52 48319



48079
Decal - Key Switch
(Located Near Keyswitch)

NOT SHOWN

48514
Decal - SCAG Zero Turn Radius
(Located on Oil Reservoir)

HANDLE ASSEMBLY

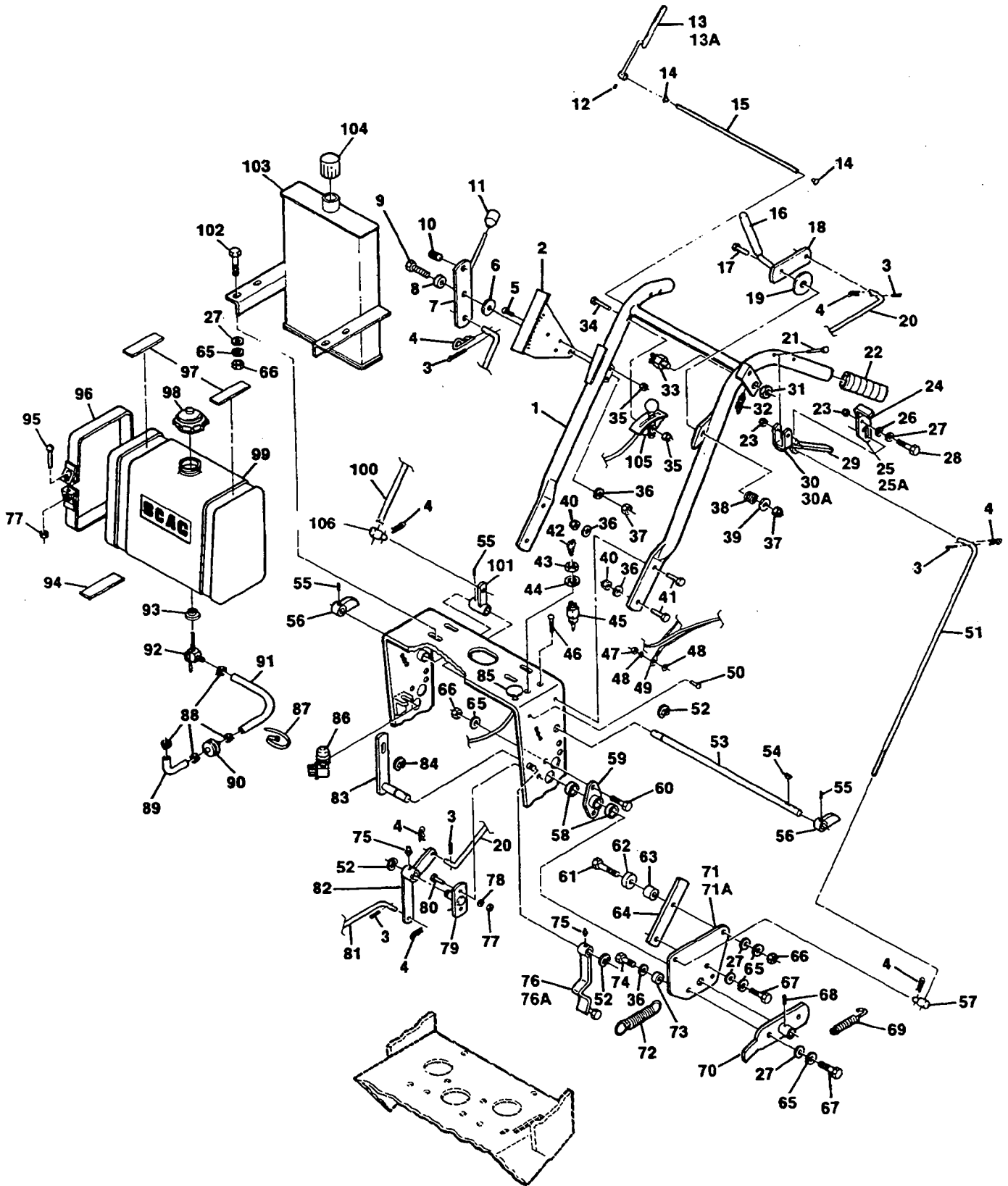

HANDLE ASSEMBLY

| Ref. No. | Part No. | Description | 14KA | 14KH | 18KH | 20EKH |
|----------|----------|---|------|------|------|-------|
| 1 | 45280 | Handle Assy. | X | X | X | X |
| 2 | 42675 | Quadrant, Speed Control | X | X | X | X |
| 3 | * | Cotter Pin, 3/32 x 3/4 | X | X | X | X |
| 4 | 04062-02 | Hair Pin, Small | X | X | X | X |
| 5 | 04014-01 | Capscrew, 1/4-20 x .75 Flat Hd. Hex Socket | X | X | X | X |
| 6 | 04040-09 | Flat Washer, .656 ID x 1.312 OD x .095 | X | X | X | X |
| 7 | 45282 | Speed Adjustment Lever | X | X | X | X |
| 8 | 43086 | Bushing, Speed Adjustment Lever | X | X | X | X |
| 9 | * | Bolt, Hex Hd., 3/8-16 X 1-1/4 | X | X | X | X |
| 10 | 48493-01 | Ball Plunger | X | X | X | X |
| 11 | 48092 | Knob, Speed Adjustment Lever | X | X | X | X |
| 12 | * | Set Screw, 1/4-28 x 1 Knurled Cup Point | X | X | X | X |
| 13 | 45142 | Safety Interlock, Hand Grip - LH | X | X | X | X |
| 13A | 45141 | Safety Interlock, Hand Grip - RH | X | X | X | X |
| 14 | 48312 | Bushing, Control Rod | X | X | X | X |
| 15 | 44014 | Rod, Control Pivot | X | X | X | X |
| 16 | 48326 | Grip, Cutter Deck Engage | X | X | X | X |
| 17 | * | Bolt, Hex Hd., 3/8-16 x 1-3/4 | X | X | X | X |
| 18 | 46090 | Blade Clutch Lever Assy. (Includes grip) | X | X | X | X |
| 19 | 04041-10 | Flat Washer, 3/8 x 2 x 16 ga. | X | X | X | X |
| 20 | 46076 | Rod, Belt Clutch - Cutter | X | X | X | X |
| 21 | * | Carriage Bolt, 5/16-18 x 2-1/2, Rd. Hd. Sq. Nk. | X | X | X | X |
| 22 | 48159 | Grip, Handle | X | X | X | X |
| 23 | * | Hex Nut, 5/16-18, Elastic Stop | X | X | X | X |
| 24 | 48324-01 | Grip, Neutral Latch - RH | X | X | X | X |
| 24 | 48324-02 | Grip, Neutral Latch - LH | X | X | X | X |
| 25 | 46083-01 | Neutral Latch - RH (Includes grip) | X | X | X | X |
| 25A | 46083-02 | Neutral Latch - LH (Includes grip) | X | X | X | X |
| 26 | 04032-01 | Curved Spring Washer | X | X | X | X |
| 27 | * | Flat Washer, 5/16 | X | X | X | X |
| 28 | * | Bolt, Hex Hd., 5/16-18 x 2 | X | X | X | X |
| 29 | 48492 | Grip, Steering Control | X | X | X | X |
| 30 | 46333 | Steering Control Lever - RH (Includes grip) | X | X | X | X |
| 30A | 46334 | Steering Control Lever - LH (Includes grip) | X | X | X | X |
| 31 | 04026-01 | Hex Nut, 9/16-18 Spring Steel | X | X | X | X |
| 32 | 48313 | Spring, Grip Return | X | X | X | X |
| 33 | 48021 | Switch, Interlock (gold colored) | X | X | X | X |
| 34 | * | Bolt, Hex Hd., 1/4-20 x 2 | X | X | X | X |
| 35 | * | Hex Nut, 1/4-20 Elastic Stop | X | X | X | X |
| 36 | * | Flat Washer, 3/8 | X | X | X | X |
| 37 | * | Hex Nut, 3/8-16 Elastic Stop | X | X | X | X |
| 38 | 48050 | Spring, Compression | X | X | X | X |
| 39 | * | Flat Washer, 25/64 x 15/16 x 12 ga. | X | X | X | X |
| 40 | * | Hex Nut, 3/8-16 Elastic Stop | X | X | X | X |
| 41 | * | Bolt, Hex Hd., 3/8-16 x 1 | X | X | X | X |
| 42 | 48017-02 | Key, Ignition | X | X | X | X |
| 43 | 48017-04 | Hex Nut, 5/8-32 | X | X | X | X |
| 44 | 48017-03 | Lockwasher, 5/8 Internal Tooth | X | X | X | X |
| 45 | 48171 | Switch, Ignition | X | X | X | X |
| 45 | 48017 | Switch, Ignition | | | | X |
| 46 | * | Bolt, Hex Hd., 1/4-20 x 1/2 | X | X | X | X |
| 47 | * | Hex Nut, #10-32 | X | X | X | X |
| 48 | * | Lockwasher, #10 External Tooth | X | X | X | X |
| 49 | 48495 | Wire Harness | X | X | X | X |
| 49 | 48496 | Wire Harness | | | | X |
| NS | 48527 | Wire Harness Adapter | X | | | |
| 50 | * | Machine Screw, #10-32 x 1/2 Phillips | X | X | X | X |
| 51 | 46294 | Control Rod, Steering | X | X | X | X |
| 52 | 04050-01 | Retaining Ring, 5/8 Ext. - "E" | X | X | X | X |
| 53 | 43155 | Jackshaft, Speed Control | X | X | X | X |

* Common hardware which should be purchased locally. All bolts grade 5 plated, all other fasteners zinc plate.

HANDLE ASSEMBLY CONTINUED ON NEXT PAGE

HANDLE ASSEMBLY CONT'D

See Page 16 For Illustration

| Ref. No. | Part No. | Description | 14KA | 14KH | 18KH | 20EKH |
|----------|----------|--|------|------|------|-------|
| 54 | 04063-13 | Key, 1/8 x 1/2 Woodruff #3 | x | x | x | x |
| 55 | * | Setscrew, Hex Socket Knurled Cup Pt., 1/4-28 x 1/4 | x | x | x | x |
| 56 | 46335 | Cam, Speed Control (Includes setscrew) | x | x | x | x |
| 57 | 43157 | Swivel Joint, Steering Rod | x | x | x | x |
| 58 | 48100-04 | Bushing | x | x | x | x |
| 59 | 46336 | Pivot, Pump Control Shaft (Includes bushings and grease fitting) | x | x | x | x |
| 60 | * | Bolt, Hex Hd., 5/16-18 x 1 | x | x | x | x |
| 61 | 04001-69 | Bolt, Hex Hd., 5/16-18 x 1-3/4 Full Thread | x | x | x | x |
| 62 | 48409 | Bearing, Speed Control | x | x | x | x |
| 63 | 43161 | Spacer, Speed Control Bearing | x | x | x | x |
| 64 | 42730 | Bar, Speed Control Adjustment | x | x | x | x |
| 65 | * | Lockwasher, 5/16 | x | x | x | x |
| 66 | * | Hex Nut, 5/16-18 | x | x | x | x |
| 67 | * | Bolt, Hex Hd., 5/16-18 x 3/4 | x | x | x | x |
| 68 | 04065-02 | Drive Pin, 5/32 x 7/8 | x | x | x | x |
| 69 | 48051 | Spring, Neutral Return | x | x | x | x |
| 70 | 45292 | Handle, Neutral Adjustment | x | x | x | x |
| 71 | 45271 | Bellcrank, LH Control | x | x | x | x |
| 71A | 45272 | Bellcrank, RH Control | x | x | x | x |
| 72 | 48494 | Spring, Speed Control | x | x | x | x |
| 73 | 48224 | Bearing, Neutral Return | x | x | x | x |
| 74 | * | Bolt, Hex Hd., 3/8-16 x 3/4 | x | x | x | x |
| 75 | 48114-01 | Grease Fitting, Straight 1/4-28 | x | x | x | x |
| 76 | 46337 | Neutral Cam, RH (Includes grease fitting) | x | x | x | x |
| 76A | 46338 | Neutral Cam, LH (Includes grease fitting) | x | x | x | x |
| 77 | * | Hex Nut, 1/4-20 | x | x | x | x |
| 78 | * | Lockwasher, 1/4 | x | x | x | x |
| 79 | 45094 | Bellcrank Pivot Weldment | x | x | x | x |
| 80 | * | Bolt, Hex Hd., 1/4-20 x 1 | x | x | x | x |
| 81 | 44003 | Rod, Blade Clutch - Lower | x | x | x | x |
| 82 | 46339 | Bellcrank, Cutter Engage (Includes grease fitting) | x | x | x | x |
| 83 | 45295 | Shaft, LH Pump Control | x | x | x | x |
| 84 | * | Retaining Ring, 1/2" Ext. - "E" | x | x | x | x |
| 85 | 48091 | Choke Control | x | x | x | x |
| 86 | 48026 | Switch, Neutral | x | x | x | x |
| 87 | 48028-01 | Cable Tie | x | x | x | x |
| 88 | 48059-01 | Clamp, Fuel Hose | x | x | x | x |
| 89 | 48179-01 | Fuel Hose, Short 7/32 ID x 3-1/2 (KA only) | x | | | |
| 90 | 48057-02 | Fuel Filter | x | | | |
| 91 | 48058-05 | Fuel Hose, 1/4 ID x 20 | x | | | |
| 91 | 48058-10 | Fuel Hose, 1/4" x 10" | | x | | |
| 91 | 48058-02 | Fuel Hose, 1/4 ID x 14-1/8 (KH only) | | | x | x |
| 92 | 48308 | Valve, Fuel Shut-off | x | x | x | x |
| 93 | 48309 | Bushing | x | x | x | x |
| 94 | 48205 | Pad, Rubber - Fuel Tank - Lower | x | x | x | x |
| 95 | * | Machine Screw, 1/4-20 x 2 Round Hd. Slotted | x | x | x | x |
| 96 | 42369 | Strap, Fuel Tank | x | x | x | x |
| 97 | 48292 | Pad, Rubber - Fuel Tank - Upper | x | x | x | x |
| 98 | 48311 | Fuel Tank Cap | x | x | x | x |
| 99 | 46174 | Fuel Tank Assembly (Includes items 92, 93, 98 and decals) | x | x | x | x |
| 100 | 46295 | Rod, Traction Control | x | x | x | x |
| 101 | 45279 | Bellcrank, Speed Control | x | x | x | x |
| 102 | * | Carriage Bolt, 5/16-18 x 1 Rd. Hd. Sq. Nk. | x | x | x | x |
| 103 | 45276 | Oil Reservoir | x | x | x | x |
| 104 | 48535 | Cap, Oil Reservoir | x | x | x | x |
| 105 | 48394 | Throttle Control | x | x | | |
| 105 | 48266 | Throttle Control | | | x | x |
| 106 | 43032 | Swivel Joint, Speed Control Rod | x | x | x | x |

* Common hardware which should be purchased locally. All bolts grade 5 plated, all other fasteners zinc plate.

ELECTRIC START ELECTRICAL SYSTEM

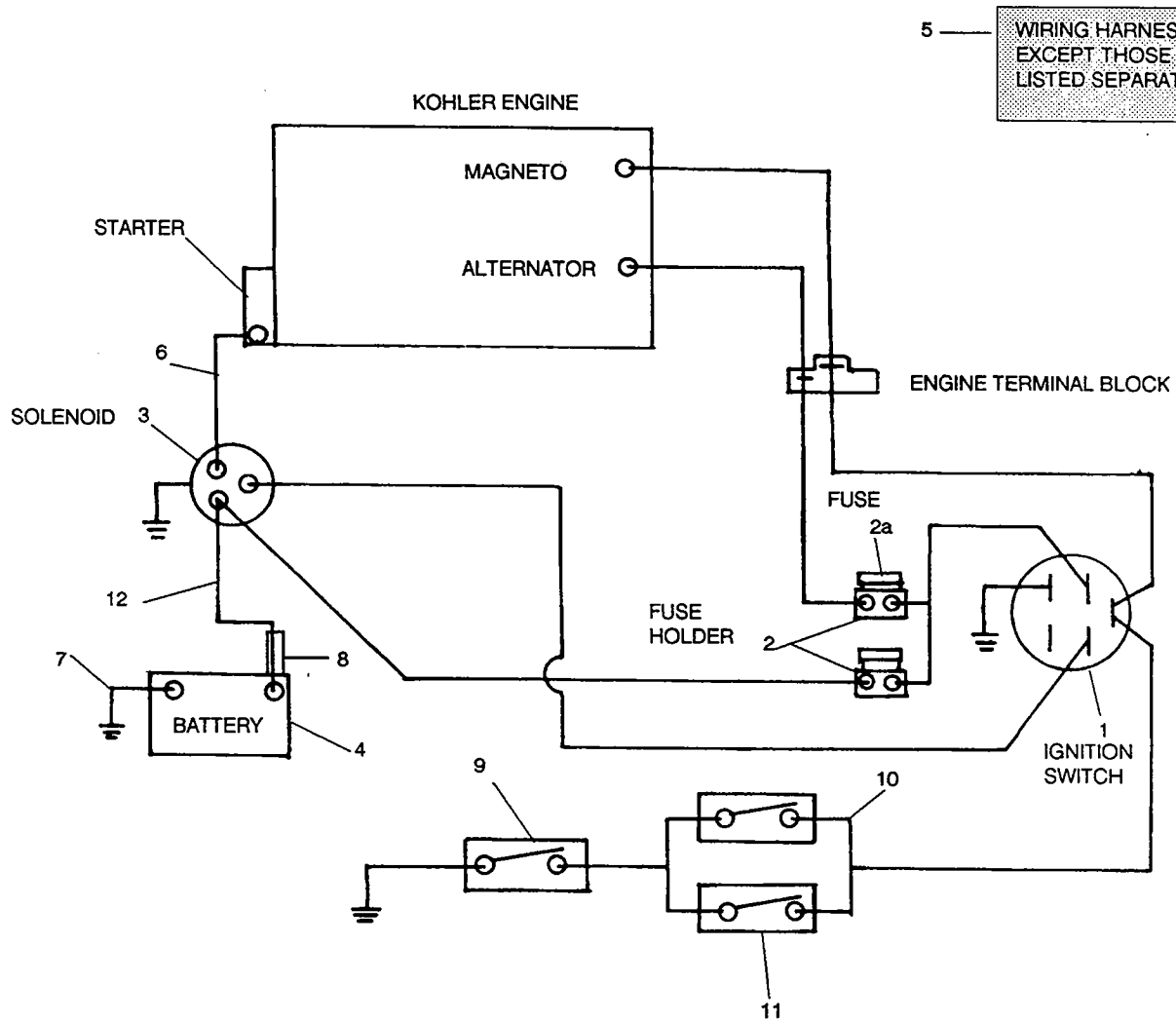

| Ref. No. | Part No. | Description | SWZ 20KHE |
|----------|----------|--|-----------|
| 1 | 48017 | Key Switch | x |
| 2 | 48297 | Fuse Holder | x |
| 2a | 48298 | Fuse 20 Amps | x |
| 3 | 48016 | Solenoid | x |
| 4 | 48015 | Battery may be purchased locally (U9-LM) | x |
| 5 | 48496 | Wiring Harness Complete | x |
| 6 | 48029-03 | Battery Cable - 13-3/4" Red | x |
| 7 | 48029-07 | Battery Cable - 18" Black | x |
| 8 | 48126 | Rubber Boot | x |
| 9 | 48021 | Switch, Handle Interlock N.C. | x |
| 10 | 48305 | Switch, Cutter Drive Interlock N.C. | x |
| 11 | 48026 | Switch, Neutral Interlock N.C. | x |
| 12 | 48029-06 | Battery Cable - 18" Red | x |

WIRING DIAGRAM FOR MANUAL START

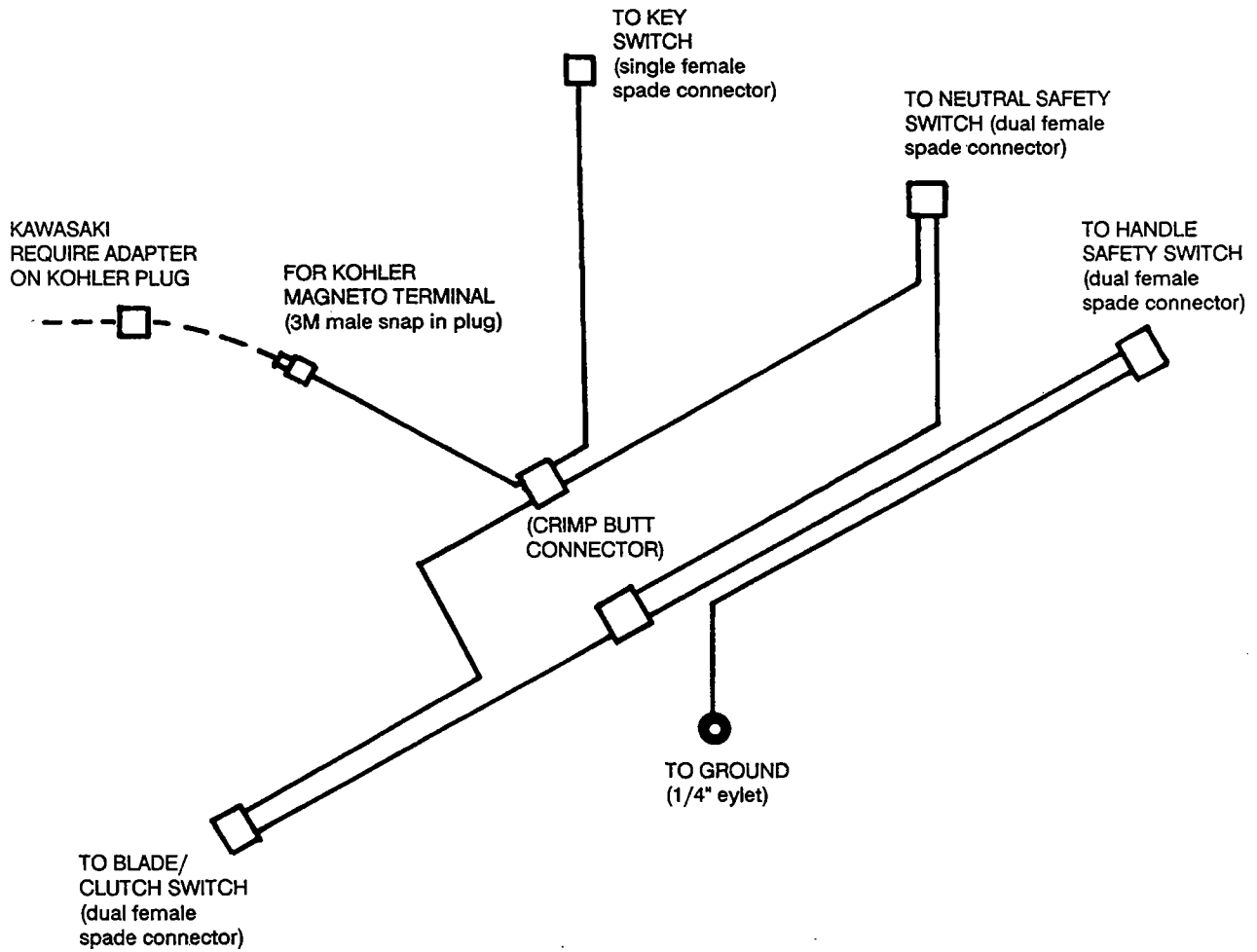

WARNING

If incorrectly used, this machine can cause severe injury. Those who use and maintain the machine should be trained in its proper use, warned of its dangers, and should read the entire manual before attempting to set up, operate, adjust or service the machine.

LIMITED WARRANTY-COMMERCIAL EQUIPMENT

Any part of the Scag commercial mower manufactured by Scag and found, in the reasonable judgment of Scag, to be defective in material or workmanship, will be repaired or replaced by an Authorized Scag Service Dealer without charge for parts and labor.

The Scag mower including any defective part must be returned to an Authorized Scag Service Dealer within the warranty period. The expense of delivering the mower to the dealer for warranty work and the expense of returning it back to the owner after repair or replacement will be paid for by the owner. Scag's responsibility in respect to claims is limited to making the required repairs or replacements, and no claim of breach of warranty shall be cause for cancellation or rescission of the contract of sale of any Scag mower. Proof of purchase will be required by the dealer to substantiate any warranty claim. All warranty work must be performed by an Authorized Scag Service Dealer.

This warranty is limited to one year from the date of original retail purchase for any Scag mower that is used for commercial purposes, or any other income-producing purpose (90 days for rental use). Traction drive system will be warranted for two full years from date of original retail purchase against defects in material or workmanship excluding hoses, lines and drive belts. Belts and tires are warranted for 90 days against defects in workmanship or materials.

This warranty does not cover any mower that has been subject to misuse, neglect, negligence, or accident, or that has been operated in any way contrary to the operating instructions as specified in the Technical Manual. The warranty does not apply to any damage to the mower that is the result of improper maintenance, or to any mower or parts that have not been assembled or installed as specified in the Technical Manual.

The warranty does not cover any mower that has been altered or modified. In addition, the warranty does not

extend to repairs made necessary by normal wear, or by the use of parts or accessories which, in the reasonable judgment of Scag, are either incompatible with the Scag mower or adversely affect its operation, performance or durability. This warranty does not cover engines and electric starters, which are warranted separately by their manufacturer.

Scag Power Equipment reserves the right to change or improve the design of any mower without assuming any obligation to modify any mower previously manufactured.

All other implied warranties are limited in duration to the one (1) year warranty period or ninety (90) days for mowers used for rental purpose. Accordingly, any such implied warranties including merchantability, fitness for a particular purpose, or otherwise, are disclaimed in their entirety after the expiration of the appropriate one-year or ninety day warranty period. Scag's obligation under this warranty is strictly and exclusively limited to the repair or replacement of defective parts and Scag does not assume or authorize anyone to assume for them any other obligation. Some states do not allow limitations on how long an implied warranty lasts, so the above limitation may not apply to you.

Scag assumes no responsibility for incidental, consequential or other damages including, but not limited to, expense for gasoline, expense of delivering the mower to an Authorized Scag Service Dealer and expense of returning it back to the owner, mechanic's travel time, telephone or telegram charges, rental of a like product during the time warranty repairs are being performed, travel, loss or damage to personal property, loss of revenue, loss of use of the mower, loss of time or inconvenience. Some states do not allow the exclusion or limitation of incidental or consequential damages. So the above limitation or exclusion may not apply to you.

This warranty gives you specific legal rights, and you may also have other rights which vary from state to state.

PLEASE BE CAREFUL

1. Keep all shields in place, especially grass discharge.
2. Stop machine and remove spark plug wire to adjust or service.
3. When mechanism becomes clogged, stop engine before cleaning.
4. Keep hands, feet and clothing away from power-drive parts.
5. Keep off implement unless seat or platform is provided.
6. Keep others off.

FAILURE TO FOLLOW CAUTIOUS OPERATING PRACTICES MAY RESULT IN SERIOUS BODILY INJURY. BESIDES, WE WOULD LIKE YOU TO CONTINUE TO ENJOY AND PROFIT BY USING OUR PRODUCTS.

OWNER REFERENCE

MODEL NUMBER _____

SERIAL NUMBER _____

ENGINE MODEL _____

SERIAL NUMBER _____

Free Manuals Download Website

<http://myh66.com>

<http://usermanuals.us>

<http://www.somanuals.com>

<http://www.4manuals.cc>

<http://www.manual-lib.com>

<http://www.404manual.com>

<http://www.luxmanual.com>

<http://aubethermostatmanual.com>

Golf course search by state

<http://golfingnear.com>

Email search by domain

<http://emailbydomain.com>

Auto manuals search

<http://auto.somanuals.com>

TV manuals search

<http://tv.somanuals.com>