

# **SCAG**

**POWER EQUIPMENT**

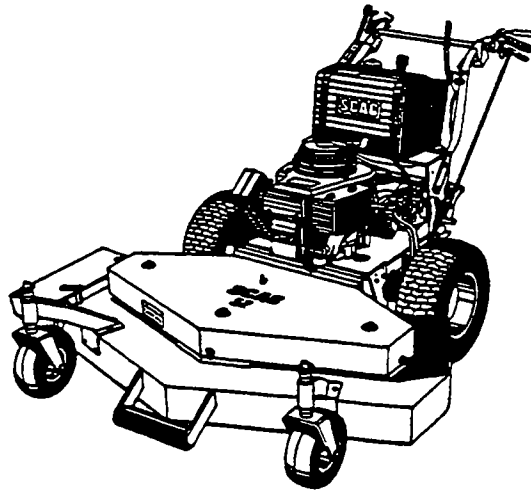

## **KEY IDENTIFYING FEATURES**

**ALL UNITS LISTED**

**PUMP AND MOTOR DRIVE SYSTEM**  
**HYDROSTATIC OIL RESERVOIR**  
**EYEBOLT TURNBUCKLE ENGAGEMENT SYSTEM**  
**SPEED ADJUSTMENT LEVER**

### **MODEL#**

**SWZ36-14KA**  
**SWZ36-14KH**  
**SWZ48-14KA**  
**SWZ48-14KH**

**SWZ-14KA**  
**SWZ-14KH**  
**SWZ-18KH**  
**SWZ-20KHE**

**SWM-52**  
**SWM-61**  
**SWM-72**

**SWF**

# 36" CUTTER DECK

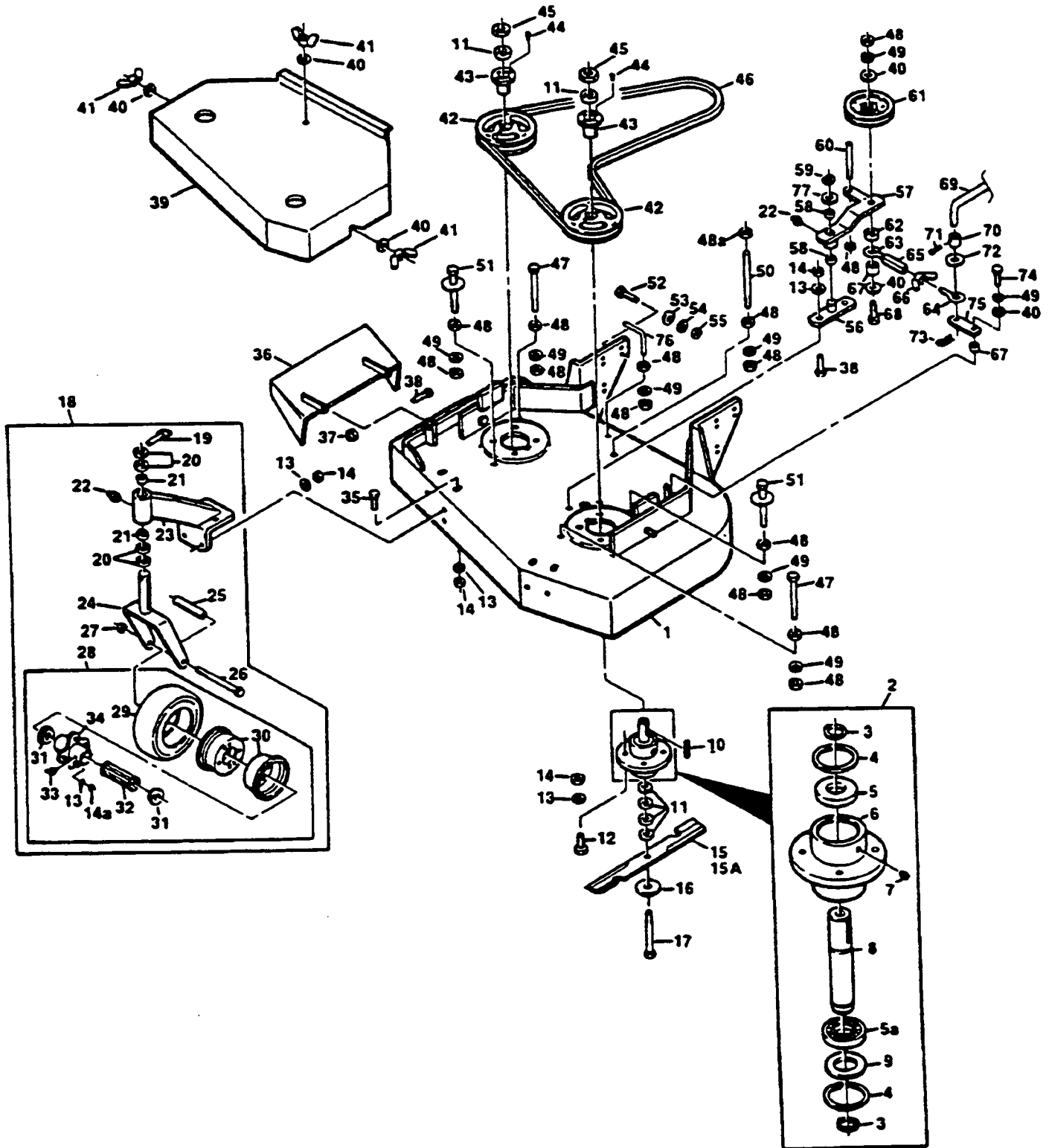

## 36" CUTTER DECK

Ref. Part No. Number	Description	Ref. Part No. Number	Description		
1	46087	Cutter Deck (Includes Decals)	39	46085	Belt Cover Assembly (Includes Decal)
2	46020	Cutter Spindle Assy. (Includes Items 3-9)	40	"	Washer, 25/64 x 15/16 x 12 ga..
3	04050-04	Retaining Ring, 1" Ext.-Inverted	40a	"	Washer, 13/32 x 13/16 x 16 ga.
4	04050-07	Retaining Ring, 2-7/16 Int.bsc	41	04022-04	Wing Nut, 3/8-16 Elastic Stop
5	48101-02	Bearing, Spindle	42	48127	Pulley (Includes Items 43-44)
6	41001	Spindle Housing	43	48141	Tapered Hub
7	48114-02	Grease Fitting, Str., 5/16 Serr	44	"	Hex Hd. Bolt, 1/4-20 x 3/4
8	43001-02	Spindle, Cutter Blade	45	"	Hex Nut, 5/8-11
9	04041-02	Washer, 1-5/16 x 2-7/16 x 16 ga.	46	48204	Belt, Blade Drive
10	04063-08	Key, 1/4 x 1/4 x 2	47	"	Hex Hd. Bolt, 3/8-16 x 5
11	43038	Spacer, Cutter Blade	48	"	Hex Nut, 3/8-16
12	"	Hex Hd. Bolt, 5/16-18 x 1-1/4	48a	"	Hex Nut, 3/8-16 Ctr Locknut
13	"	Lockwasher, Spring, 5/16	49	"	Lockwasher, Spring 3/8
14	"	Hex Nut, 5/16-18	50	04004-02	Support, Belt Cover
14a	"	Hex Nut, 5/16-24	51	45098	Belt Guide
15	48108	Cutter Blade 18"	52	"	Hex Hd. Bolt, 7/16-14 x 1-1/4
15a	48185	Cutter Blade 18" Hi Lift	53	"	Washer, 15/32 x 59/64 x 16 ga.
16	04040-10	Flat Washer, 5/8 W	54	"	Lockwasher, Spring, 7/16
17	04001-41	Hex Hd. Bolt, 5/8-11 x 9-1/2	55	"	Hex Nut, 7/16-14 Elastic Stop
18	46079	Caster Assembly (Includes Items 19-28)	56	45037	Idler Pivot
19	04066-01	Quick Pin	57	46145	Idler Arm Assy. (Includes Items 22 & 58)
20	43037-01	Spacer, Caster Yoke, 1/2" long	58	48100-05	Bronze Bearing
21	48100-01	Bronze Bearing	59	04050-02	Retaining Ring, 3/4 Ext.-"E"
22	48114-01	Grease Fitting, Str. 1/4-28	60	04004-04	Stud
23	46082	Support Assembly.	61	48269	Idler Pulley, Belt Clutch
24	45006	Caster Yoke	62	43063	Spacer, Idler
25	43022	Sleeve, Caster Wheel Brg	63	04070-02	Eyebolt, LH
26	04001-37	Hex Hd. Bolt, 1/2-13 x 5-1/2	64	04070-01	Eyebolt, RH
27	"	Hex Locknut, 1/2-13	65	43025	Turnbuckle
28	48307-01	Wheel Assy. (Includes 13-14a, 29-34)	66	04022-02	Wing Nut, 5/16-18
29	48307-02	Tire Only Caster Wheel	67	43042	Sleeve, Clutch Rod
	48006-03	Inner Tube only	68	"	Hex Hd. Bolt, 3/8-16 x 2-3/4
30	48307-04	Rim Pair, Caster Wheel	69	44064	Blade Clutch Rod, Lower
31	48006-07	Retainer, Bearing, Caster Wheel	70	43043	Sleeve, Clutch Rod
32	48006-06	Roller Bearing, Caster Wheel	71	"	Cotter Pin, 3/32 x 1
33	48114-03	Grease Fitting, 45° 1/4-28	72	"	Washer, 33/64 x 1 x 16 ga.
34	48006-05	Hub Assembly	73	04062-01	Hex Pin, Large
35	"	Hex Hd Bolt, 5/16-18 x 3/4	74	"	Hex Hd. Bolt, 3/8-16 x 1
36	45100	Discharge Chute	75	42057	Cam Link
37	"	Hex Nut, 5/16-18 Elastic Stop	76	44009	Belt Guide
38	"	Hex Hd Bolt, 5/16-18 x 1	77	04041-08	Washer, 3/4 x 1-1/4 x .035

\* Common hardware which should be purchased locally. All bolts are Grade 5 plated, all other fasteners are zinc plated.

# 48", 52", 61", & 72" CUTTER DECKS

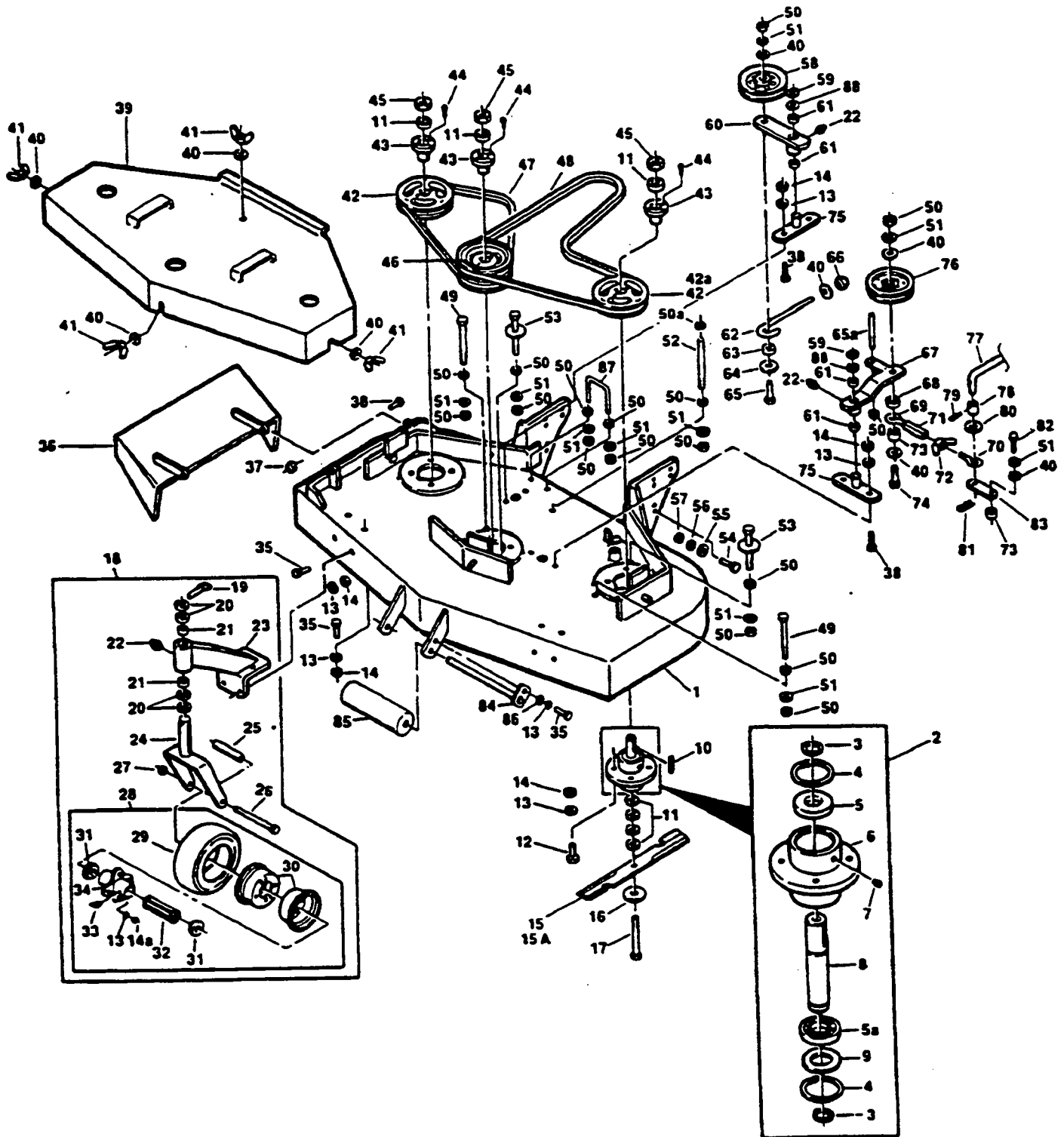

## 48", 52", 61", & 72" CUTTER DECKS

Ref. Part No. No.	Description	48	52	61	72	Ref. Part No. No.	Description	48	52	61	72
1 46088	Cutter Deck (Includes decals)	x				42a 48299	Pulley (Includes 43-44)				x
1 46163	Cutter Deck (Includes decals)		x			43 48141	Tapered Hub	x	x	x	x
1 46119	Cutter Deck (Includes decals)			x		44 "	Hex Hd. Bolt, 1/4-20 x 3/4	x	x	x	x
1 46194	Cutter Deck (Includes decals)				x	45 "	Hex Nut, 5/8-11	x	x	x	x
2 46020	Cutter Spindle Assy. (Includes 3-9)	x	x	x	x	46 48412	Pulley, Double (Includes 43-44)	x	x		
3 04050-04	Retaining Ring, 1" Ext. Inverted	x	x	x	x	46 48302	Pulley, Double (Includes 43-44)				x
4 04050-07	Retaining Ring, 2-7/16" Int. Basic	x	x	x	x	47 48087	Belt, RH Blade Drive	x			
5 48101-02	Bearing, Cutter Spindle	x	x	x	x	47 48285	Belt, RH Blade Drive		x		
6 43001	Spindle Housing	x	x	x	x	47 48265	Belt, RH Blade Drive			x	
7 48114-02	Grease Fitting Str., 5/16 Serr.	x	x	x	x	47 48295	Belt, RH Blade Drive				x
8 43001-02	Spindle, Cutter Blade	x	x	x	x	48 48089	Belt, Blade Drive	x			
9 04041-02	Washer, 1-5/16 x 2-7/16 x 16 ga.	x	x	x	x	48 48286	Belt, Blade Drive		x		
10 04063-08	Key, 1/4 x 1/4 x 2	x	x	x	x	48 48264	Belt, Blade Drive			x	
11 43038	Spacer, Cutter Blade	x	x	x	x	48 48296	Belt, Blade Drive				x
12 "	Hex Hd. Bolt, 5/16-18 x 1-1/4	x	x	x	x	49 "	Hex Hd. Bolt, 3/8-16 x 5"	x	x	x	x
13 "	Lockwasher, Spring, 5/16	x	x	x	x	50 "	Hex Nut, 3/8-16	x	x	x	x
14 "	Hex Nut, 5/16-18	x	x	x	x	50a "	Hex Nut, 3/8-16, Centerlock	x	x	x	x
14a "	Hex Nut, 5/16-24	x	x	x	x	51 "	Lockwasher, Spring, 3/8	x	x	x	x
15 48110	Cutter Blade 16-1/2"	x				52 04004-02	Support, Belt Cover	x	x	x	x
15 48108	Cutter Blade 18"	x				53 45098	Belt Guide	x	x	x	x
15 48111	Cutter Blade 21"		x			54 "	Hex Hd. Bolt, 7/16-14 x 1-1/2	x	x	x	x
15 48112	Cutter Blade 24"			x		55 "	Washer, 15/32 x 59/64 x 16 ga.	x	x	x	x
15a 48184	Cutter Blade 16-1/2" Hi Lift	x				56 "	Lock Washer, Spring, 7/16	x	x	x	x
15a 48185	Cutter Blade 18" Hi Lift		x			57 "	Hex Nut, 7/16-14	x	x	x	x
16 04040-10	Flat Washer, 5/8" W	x	x	x	x	58 48181	Idler Pulley, "V" Groove	x	x	x	x
17 04001-41	Hex Hd. Bolt, 5/8-11 x 9-1/2"	x	x	x	x	58 04050-02	Retaining Ring, 3/4" Ext. "E"	x	x	x	x
18 46078	Caster Assy. Comp. (incl. 19-28)	x	x	x	x	60 46081	Idler Arm Assy. (Includes 22 & 61)	x	x	x	x
19 04066-01	Quick Pin	x	x	x	x	61 48100-05	Bronze Bearing	x	x	x	x
20 43037-01	Spacer, Caster Yoke, 1/2" thick	x	x	x	x	62 43028	J Rod, Idler Post	x	x	x	x
21 48100-01	Bronze Bearing	x	x	x	x	63 43077	Spacer, J Pull Rod	x	x	x	x
22 48114-01	Grease Fitting, Str., 1/4-28	x	x	x	x	64 04041-12	Washer, 3/8 x 1-1/2 x 16 ga.	x	x	x	x
23 46082	Support Assy. (incl. 21-22)	x	x	x	x	65 "	Hex Hd. Bolt, 3/8-16 x 2-1/4	x	x	x	x
24 45006	Caster Yoke	x	x	x	x	65a 04004-04	Stud	x	x	x	x
25 43022	Sleeve, Caster Wheel Bearing	x	x	x	x	66 "	Hex Nut, 3/8-16 Elastic Stop	x	x	x	x
26 04001-37	Hex Hd Bolt, 1/2-13 x 5-1/2"	x	x	x	x	67 46145	Idler Arm (Includes 22 & 61)	x	x	x	x
27 "	Hex Locknut, 1/2-13	x	x	x	x	68 43063	Spacer	x	x	x	x
28 48307-01	Wheel Assy. (incl. 13-14, 29-34)	x	x	x	x	68 04070-02	Eyebolt, LH	x	x	x	x
29 48307-02	Tire only, Caster Wheel	x	x	x	x	70 04070-01	Eyebolt, RH	x	x	x	x
29 48006-03	Inner Tube only, Caster Wheel	x	x	x	x	71 43025	Turnbuckle	x	x	x	x
30 48307-04	Rim Pair, Caster Wheel	x	x	x	x	72 04022-02	Wing Nut, 5/16-18	x	x	x	x
31 48006-07	Retainer, Bearing, Caster Wheel	x	x	x	x	73 43042	Sleeve, Cam Clutch	x	x	x	x
32 48006-06	Roller Bearing, Caster Wheel	x	x	x	x	74 "	Hex Hd Bolt, 3/8-16 x 2-3/4	x	x	x	x
33 48114-03	Grease Fitting 45° 1/4-28	x	x	x	x	75 45037	Idler Pivot	x	x	x	x
34 48006-05	Hub Assy. (incl. bolts)	x	x	x	x	76 48269	Idler Pulley, Belt Clutch	x	x	x	x
35 "	Hex Hd. Bolt, 5/16-18 x 3/4"	x	x	x	x	77 44064	Blade Clutch Rod, Lower	x	x	x	x
36 45029	Discharge Chute	x	x	x		78 43043	Sleeve, Clutch Rod	x	x	x	x
36 45100	Discharge Chute	x				79 "	Caster Pin, 3/32 x 1	x	x	x	x
37 "	Hex Nut, 5/16-18 Elastic Stop	x	x	x	x	80 "	Washer, 33/64 x 1 x 15 ga.	x	x	x	x
38 "	Hex Hd. Bolt, 5/16-18 x 1	x	x	x	x	81 04062-01	Har Pin Large	x	x	x	x
39 46086	Belt Cover (Includes decals)	x				82 "	Hex Hd Bolt, 3/8-16 x 1	x	x	x	x
39 46164	Belt Cover (Includes decals)		x			83 42057	Cam Link	x	x	x	x
39 46121	Belt Cover (Includes decals)			x		84 45046	Roller Shaft	x	x	x	x
39 46312	Belt Cover (Includes decals)				x	85 48038	Guide Roller	x	x	x	x
40 "	Washer 25/64 x 15/16 x 12 ga.	x	x	x	x	86 "	Flat Washer, 11/32 x 11/16 x 16 ga.	x	x	x	x
41 04022-04	Wing Nut, 3/8-16	x	x	x	x	87 44008	Belt Guide	x	x	x	x
42 48127	Pulley (Includes 43-44)	x	x	x	x	88 "	Flat Washer, 3/4 x 1-1/4 x .035	x	x	x	x

\* Common hardware which should be purchased locally. All bolt Grade 5 plated, all other fasteners zinc plated.

# ENGINE DECK

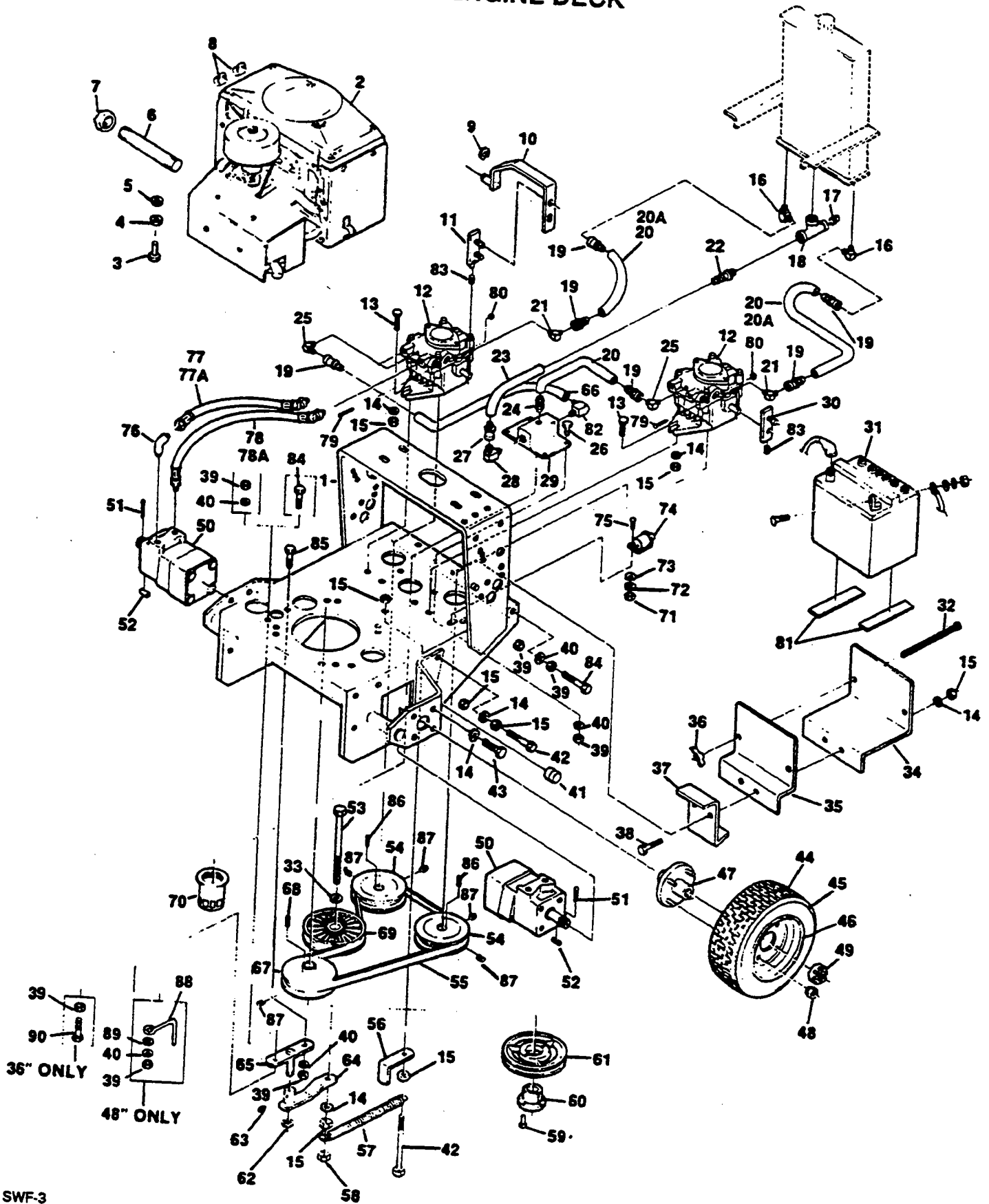

SWF-3

# ENGINE DECK

REF. PART NO.	NO.	DESCRIPTION	14KA	14KH	18KH	20KHE
1	45270	Engine Deck	x	x	x	x
2a	48528	Engine 14H Kawasaki	x			
2a	48357	Engine 14HP Kohler		x		
2b	48268	Engine 18HP Kohler (MV18 PS-58511)			x	
2b	48358	Engine 20HP Kohler El. St. (MV20 PS-57508)				x
3	*	Bolt, Hex Hd. Metric 8 x 30	x	x		
3	*	Hex Hd. Bolt, 5/16-18 x 1-1/2			x	x
4	*	Hex Nut, 5/16-18 Elastic Stop			x	x
5	*	Lockwasher, 5/16 Spring	x	x	x	x
6	48431	Pipe, 4.75" Nipple			x	x
7	48257	Pipe Cap			x	x
8	48059-01	Fuel Hose Clamp	x	x	x	x
9	04050-10	Retaining Ring, 1/2 "E"	x	x	x	x
10	45283	Shaft Widmt. - RH Pump Control	x	x	x	x
11	46324	Lever Assembly, Pump Control - RH	x	x	x	x
12	48436	Pump, Sunstrand BDP-10L100	x	x	x	x
13	*	Bolt, Carriage, 3/8-16 x 1-1/4	x	x	x	x
14	*	Lockwasher, 3/8	x	x	x	x
15	*	Hex Nut, 3/8-16	x	x	x	x
16	48484-01	Elbow, 90 deg. Female 1/4 NPT to 1/4 JIC Male	x	x	x	x
17	48117	Plug, 3/8 NPT	x	x	x	x
18	48491	Tee, Galvanized 3/8 NPT	x	x	x	x
19	48353-02	Coupling, 7/16-20 SAE Flare Swivel to 1/4" Hose Push On	x	x	x	x
20	48482-03	Hose, 1/4" ID, 8" Long	x	x	x	x
21	48350-03	Elbow, 90 deg. 7/16-20 JIC to 7/16-20 "O" Ring	x	x	x	x
22	48352-03	Coupling, 3/8 Straight Male NPT to 1/2" Hose Push On	x	x	x	x
23	48351-05	Hose, 1/2" ID, 12" Long	x	x	x	x
24	48486-01	Elbow, 90 deg. Male 1/4 NPT to 1/4" Hose Push On	x	x	x	x
25	48352-02	Coupling, 1/4 Straight Male NPT to 1/4" Hose Push On	x	x	x	x
26	*	Bolt, Hex Hd., 5/16-18 x 2-1/2	x	x	x	x
27	48353-01	Coupling, 3/4-16 SAE Flare Swivel to 1/2" Hose Push On	x	x	x	x
28	48489-02	Elbow, 90 deg. Male 3/4-16 JIC to 1/2" Male NPT	x	x	x	x
29	48471	Oil Filter Assembly (Includes item 70)	x	x	x	x
30	46323	Lever Assembly, Pump Control - LH	x	x	x	x
31	48015	Battery				x
32	*	Carriage Hd. Bolt, 1/4-20 x 6	x	x	x	x
33	*	Flatwasher, 3/8	x	x	x	x
34	45302	Battery Box				x
35	42745	Battery Clamp				x
36	04022-01	Wing Nut, 1/4-20 Elastic Stop	x	x	x	x
37	45125	Sulky Mounting Bracket (Included with Riding Sulky)				x
38	*	Bolt, Hex Hd., 3/8-16 x 1-1/4	x	x	x	x
39	*	Hex Nut, 5/16-18	x	x	x	x
40	*	Lockwasher, 5/16	x	x	x	x
41	48534	Cover, Sulky Mount	x	x	x	x
42	*	Bolt, Hex Hd., 3/8-16 x 2-3/4	x	x	x	x
43	*	Bolt, Hex Hd., 3/8-16 x 1	x	x	x	x
44	48468	Wheel Assembly (Incl. 45, 46, 47, 48)	x	x	x	x
45	48004-02	Tire, 16 x 6.50, 2 ply	x	x	x	x
46	48004-04	Rim Assembly	x	x	x	x
47	48468-05	Wheel Hub (Includes item 48)	x	x	x	x
48	48004-06	Bolt and Nut	x	x	x	x
49	04027-02	Hex Castle Nut, 3/4-28 UNEF	x	x	x	x
50	48437	Motor, White RS	x	x	x	x
51	*	Cotter Pin, 3/32 x 1-1/4	x	x	x	x
52	04063-15	Key, 3/16 x 3/16 x .75	x	x	x	x
53	*	Bolt, Hex Hd., 3/8-16 x 2-1/4	x	x	x	x
54	48470	Pulley, Pump Shaft	x	x	x	x
55	48472	Belt, Pump Drive	x	x	x	x

\* Common hardware which should be purchased locally. All bolts Grade 5 plated, all other fasteners zinc plated.

ENGINE DECK CONTINUED ON FOLLOWING PAGE

## ENGINE DECK CONT'D

See Page 3 For Illustration

REF. PART NO.	NO.	DESCRIPTION	14KA	14KH	18KH	20KHE
56	42692	Belt Guide, Cutter - Rear	x	x	x	x
57	48051	Spring, Pump Belt Idler	x	x	x	x
58	*	Hex Nut, Elastic Stop Lock, 3/8-16	x	x	x	x
59	*	Bolt, Hex Hd., 1/4-20 x 3/4	x	x	x	x
60	48141	Taper Hub (for 48127)	x	x	x	
60	48378-03	Taper Hub (for 48378)				x
61	48127	Pulley, Cutter Drive	x	x	x	
61	48378	Pulley, Cutter Drive				x
62	04050-02	Retaining Ring, 3/4 Ext. - "E"	x	x	x	x
63	48114-01	Grease Fitting	x	x	x	x
64	46340	Idler Arm, Traction Belt (Includes bushings and grease fitting)	x	x	x	x
65	45212	Pivot, Idler Arm	x	x	x	x
66	+	Part Removed From Illustration				
67	48422	Pulley, Pump Drive	x	x	x	
67	48423	Pulley, Pump Drive				x
68	04063-03	Key, 1/4 x 1/4 x 2-1/2	x	x	x	x
69	48473	Pulley, Idler - Pump Drive	x	x	x	x
70	48462-01	Oil Filter	x	x	x	x
71	*	Hex Nut, #10-32	x	x	x	x
72	*	Lockwasher, #10 Ext. Tooth	x	x	x	x
73	*	Washer (.219 x .500 x .049)	x	x	x	x
74	48305	Switch, Clutch Safety (black)	x	x	x	x
75	*	Phillips Hd. Machine Screw, 10-32 x 1/2	x	x	x	x
76	48485-02	Elbow, 45 deg. Male 7/8-14 JIC to Male 7/8-14 "O" Ring	x	x	x	x
77	48475	Hose, Pump to Motor, LH - Forward	x	x	x	x
77A	48477	Hose, Pump to Motor, RH - Forward	x	x	x	x
78	48476	Hose, Pump to Motor, LH - Reverse	x	x	x	x
78A	48478	Hose, Pump to Motor, RH - Reverse	x	x	x	x
79	48526	Lever, Dump Valve	x	x	x	x
80	*	Setscrew, #8-32 x 3/4 Socket Hd.	x	x	x	x
81	48205	Pad, Rubber				x
82	+	Part Removed From Illustration				
83	04015-02	Setscrew, #10-32 x 3/4 Socket Hd.	x	x	x	x
84	*	Bolt, Hex Hd., 5/16-18 x 1-1/2	x	x	x	x
85	*	Bolt, Hex Hd., 5/16-18 x 1	x	x	x	x
86	04063-14	Key, 5.0 x 5.0 x 25mm	x	x	x	x
87	04012-04	Setscrew, 5/16-18 x 3/8 Hex Socket Hd.	x	x	x	x
NS	43096	Spacer, Oil Filter	x	x	x	x

\* Common hardware which should be purchased locally. All bolts Grade 5 plated, all other fasteners zinc plated.



# REPLACEMENT DECALS

# SCAG

48314  
Decal - Scag's Logo  
(Located On Cutter Deck Cover - Top Surface)

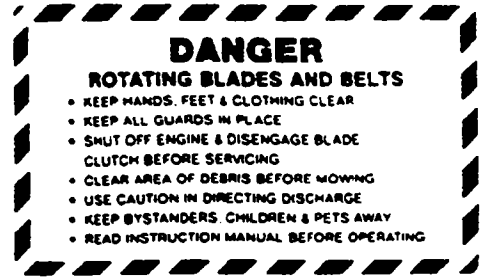

48073  
Decal - Danger, Rotating Blades  
(Located On Cutter Deck Cover - Near Discharge Chute)



48072  
Decal - Heavy Duty Commercial  
(Located On Cutter Deck Cover - Front Wall)



48524  
Decal - Speed Control  
(Located On Shift Quadrant)

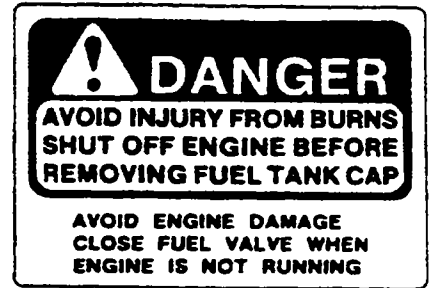

48281  
Decal - Operator Warning  
Fuel Fill  
(Located On Top of Fuel Tank)

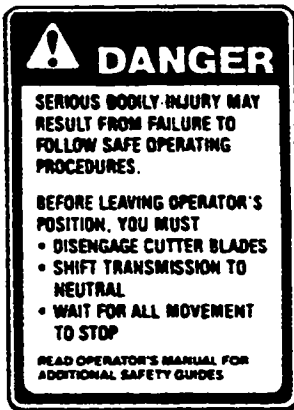

48222  
Decal - Operator Warning  
(Located On Back Of Fuel Tank)



48071  
Decal - O.P.E.I. Safety  
(Located On Cutter Deck Near Discharge Chute)

# 61

72 48327  
61 48320  
52 48319

NOT SHOWN  
48514  
Decal - SCAG Zero Turn Radius  
(Located on Oil Reservoir)



48079  
Decal - Key Switch  
(Located Near Keyswitch)

# HANDLE ASSEMBLY

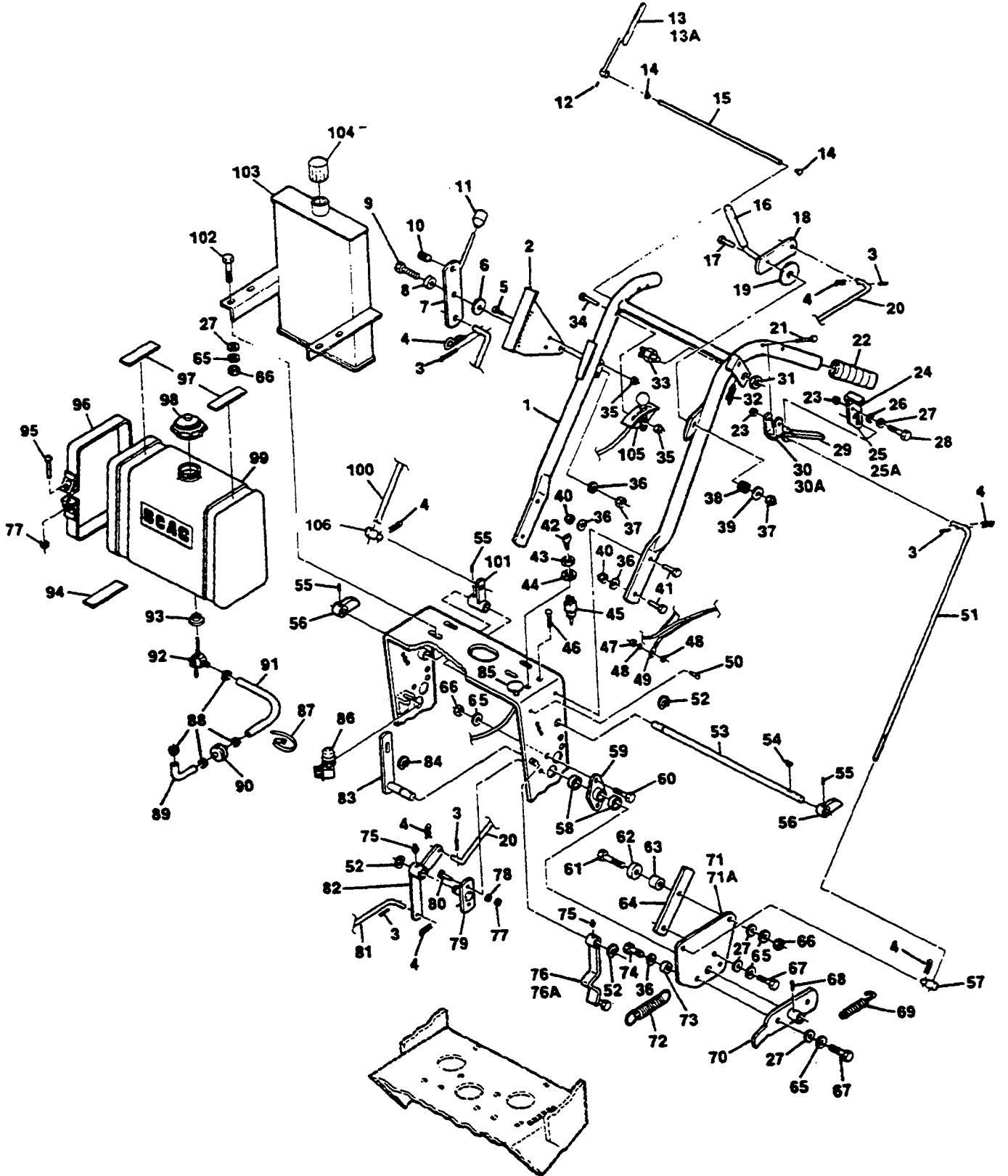

# HANDLE ASSEMBLY

REF. NO.	PART NO.	DESCRIPTION	14KA	14KH	18KH	20KHE
1	45280	Handle Assy.	x	x	x	x
2	42675	Quadrant, Speed Control	x	x	x	x
3	*	Cotter Pin, 3/32 x 3/4	x	x	x	x
4	04062-02	Hair Pin, Small	x	x	x	x
5	04014-01	Capscrew, 1/4-20 x .75 Flat Hd. Hex Socket	x	x	x	x
6	04040-09	Flat Washer, .656 ID x 1.312 OD x .095	x	x	x	x
7	45282	Speed Adjustment Lever	x	x	x	x
8	43086	Bushing, Speed Adjustment Lever	x	x	x	x
9	*	Bolt, Hex Hd., 3/8-16 X 1-1/4	x	x	x	x
10	48493-01	Ball Plunger	x	x	x	x
11	48092	Knob, Speed Adjustment Lever	x	x	x	x
12	*	Set Screw, 1/4-28 x 1 Knurled Cup Point	x	x	x	x
13	45142	Safety Interlock, Hand Grip - LH	x	x	x	x
13A	45141	Safety Interlock, Hand Grip - RH	x	x	x	x
14	48312	Bushing, Control Rod	x	x	x	x
15	44014	Rod, Control Pivot	x	x	x	x
16	48326	Grip, Cutter Deck Engage	x	x	x	x
17	*	Bolt, Hex Hd., 3/8-16 x 1-3/4	x	x	x	x
18	46090	Blade Clutch Lever Assy. (Includes grip)	x	x	x	x
19	04041-10	Flat Washer, 3/8 x 2 x 16 ga.	x	x	x	x
20	46076	Rod, Belt Clutch - Cutter	x	x	x	x
21	*	Carriage Bolt, 5/16-18 x 2-1/2, Rd. Hd. Sq. Nk.	x	x	x	x
22	48159	Grip, Handle	x	x	x	x
23	*	Hex Nut, 5/16-18, Elastic Stop	x	x	x	x
24	48324-01	Grip, Neutral Latch - RH	x	x	x	x
24	48324-02	Grip, Neutral Latch - LH	x	x	x	x
25	46083-01	Neutral Latch - RH (Includes grip)	x	x	x	x
25A	46083-02	Neutral Latch - LH (Includes grip)	x	x	x	x
26	04032-01	Curved Spring Washer	x	x	x	x
27	*	Flat Washer, 5/16	x	x	x	x
28	*	Bolt, Hex Hd., 5/16-18 x 2	x	x	x	x
29	48492	Grip, Steering Control	x	x	x	x
30	46333	Steering Control Lever - RH (Includes grip)	x	x	x	x
30A	46334	Steering Control Lever - LH (Includes grip)	x	x	x	x
31	04026-01	Hex Nut, 9/16-18 Spring Steel	x	x	x	x
32	48313	Spring, Grip Return	x	x	x	x
33	48021	Switch, Interlock (gold colored)	x	x	x	x
34	*	Bolt, Hex Hd., 1/4-20 x 2	x	x	x	x
35	*	Hex Nut, 1/4-20 Elastic Stop	x	x	x	x
36	*	Flat Washer, 3/8	x	x	x	x
37	*	Hex Nut, 3/8-16 Elastic Stop	x	x	x	x
38	48050	Spring, Compression	x	x	x	x
39	*	Flat Washer, 25/64 x 15/16 x 12 ga.	x	x	x	x
40	*	Hex Nut, 3/8-16 Elastic Stop	x	x	x	x
41	*	Bolt, Hex Hd., 3/8-16 x 1	x	x	x	x
42	48017-02	Key, Ignition	x	x	x	x
43	48017-04	Hex Nut, 5/8-32	x	x	x	x
44	48017-03	Lockwasher, 5/8 Internal Tooth	x	x	x	x
45	48171	Switch, Ignition	x	x	x	
45	48017	Switch, Ignition				x
46	*	Bolt, Hex Hd., 1/4-20 x 1/2	x	x	x	x
47	*	Hex Nut, #10-32	x	x	x	x
48	*	Lockwasher, #10 External Tooth	x	x	x	x
49	48495	Wire Harness	x	x	x	
49	48496	Wire Harness				x
NS	48527	Wire Harness Adapter	x			
50	*	Machine Screw, #10-32 x 1/2 Phillips	x	x	x	x
51	46294	Control Rod, Steering	x	x	x	x
52	04050-01	Retaining Ring, 5/8 Ext. - "E"	x	x	x	x
53	43155	Jackshaft, Speed Control	x	x	x	x

\* Common hardware which should be purchased locally. All bolts grade 5 plated, all other fasteners zinc plate.

HANDLE ASSEMBLY CONTINUED ON NEXT PAGE

# HANDLE ASSEMBLY CONT'D

See Page 7 For Illustration

REF. PART NO.	NO.	DESCRIPTION	14KA	14KH	18KH	20KHE
54	04063-13	Key, 1/8 x 1/2 Woodruff #3	x	x	x	x
55	*	Setscrew, Hex Socket Knurled Cup Pt., 1/4-28 x 1/4	x	x	x	x
56	46335	Cam, Speed Control (Includes setscrew)	x	x	x	x
57	43157	Swivel Joint, Steering Rod	x	x	x	x
58	48100-04	Bushing	x	x	x	x
59	46336	Pivot, Pump Control Shaft (Includes bushings and grease fitting)	x	x	x	x
60	*	Bolt, Hex Hd., 5/16-18 x 1	x	x	x	x
61	04001-69	Bolt, Hex Hd., 5/16-18 x 1-3/4 Full Thread	x	x	x	x
62	48409	Bearing, Speed Control	x	x	x	x
63	43161	Spacer, Speed Control Bearing	x	x	x	x
64	42730	Bar, Speed Control Adjustment	x	x	x	x
65	*	Lockwasher, 5/16	x	x	x	x
66	*	Hex Nut, 5/16-18	x	x	x	x
67	*	Bolt, Hex Hd., 5/16-18 x 3/4	x	x	x	x
68	04065-05	Drive Pin, 5/32 x 7/8 Type U	x	x	x	x
69	48051	Spring, Neutral Return	x	x	x	x
70	45292	Handle, Neutral Adjustment	x	x	x	x
71	45271	Bellcrank, LH Control	x	x	x	x
71A	45272	Bellcrank, RH Control	x	x	x	x
72	48494	Spring, Speed Control	x	x	x	x
73	48224	Bearing, Neutral Return	x	x	x	x
74	*	Bolt, Hex Hd., 3/8-16 x 3/4	x	x	x	x
75	48114-01	Grease Fitting, Straight 1/4-28	x	x	x	x
76	46337	Neutral Cam, RH (Includes grease fitting)	x	x	x	x
76A	46338	Neutral Cam, LH (Includes grease fitting)	x	x	x	x
77	*	Hex Nut, 1/4-20	x	x	x	x
78	*	Lockwasher, 1/4	x	x	x	x
79	45094	Bellcrank Pivot Weldment	x	x	x	x
80	*	Bolt, Hex Hd., 1/4-20 x 1	x	x	x	x
81	44003	Rod, Blade Clutch - Lower	x	x	x	x
82	46339	Bellcrank, Cutter Engage (Includes grease fitting)	x	x	x	x
83	45295	Shaft, LH Pump Control	x	x	x	x
84	*	Retaining Ring, 1/2" Ext. - "E"	x	x	x	x
85	48091	Choke Control			x	x
86	48026	Switch, Neutral	x	x	x	x
87	48028-01	Cable Tie	x	x	x	x
88	48059-01	Clamp, Fuel Hose	x	x	x	x
89	48179-01	Fuel Hose, Short 7/32 ID x 3-1/2 (KA only)	x			
90	48057-02	Fuel Filter	x			
91	48058-05	Fuel Hose, 1/4 ID x 20	x			
91	48058-10	Fuel Hose, 1/4" x 10"		x		
91	48058-02	Fuel Hose, 1/4 ID x 14-1/8 (KH only)			x	x
92	48308	Valve, Fuel Shut-off	x	x	x	x
93	48309	Bushing	x	x	x	x
94	48205	Pad, Rubber - Fuel Tank - Lower	x	x	x	x
95	*	Machine Screw, 1/4-20 x 2 Round Hd. Slotted	x	x	x	x
96	42369	Strap, Fuel Tank	x	x	x	x
97	48292	Pad, Rubber - Fuel Tank - Upper	x	x	x	x
98	48311	Fuel Tank Cap	x	x	x	x
99	46174	Fuel Tank Assembly (Includes items 92, 93, 98 and decals)	x	x	x	x
100	46295	Rod, Traction Control	x	x	x	x
101	45279	Bellcrank, Speed Control	x	x	x	x
102	*	Carriage Bolt, 5/16-18 x 1 Rd. Hd. Sq. Nk.	x	x	x	x
103	45276	Oil Reservoir	x	x	x	x
104	48535	Cap, Oil Reservoir	x	x	x	x
105	48394	Throttle Control	x	x		
105	48266	Throttle Control			x	x
106	43032	Swivel Joint, Speed Control Rod	x	x	x	x

\* Common hardware which should be purchased locally. All bolts grade 5 plated, all other fasteners zinc plate.

# ELECTRIC START ELECTRICAL SYSTEM

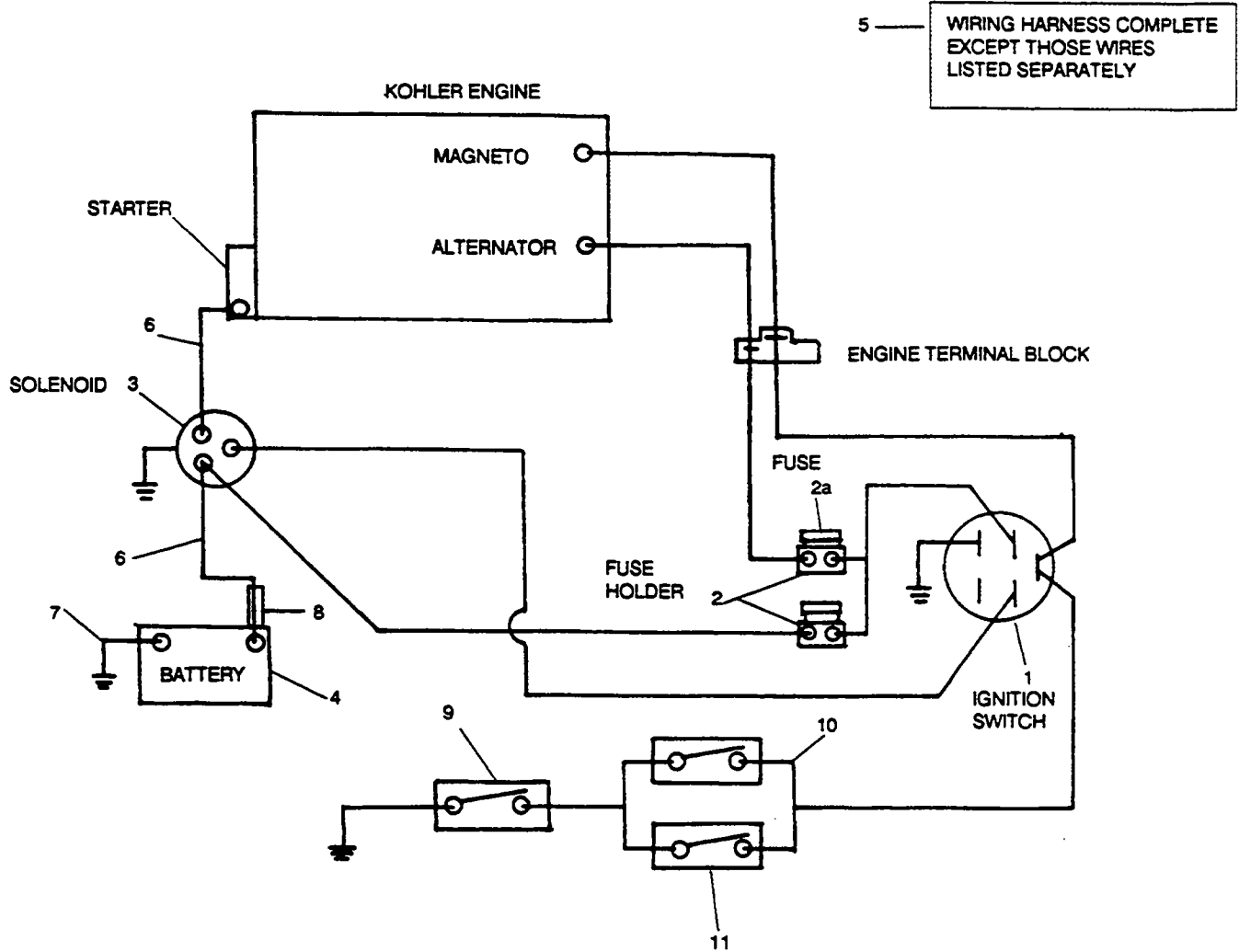

REF. NO.	PART NO.	DESCRIPTION	SWZ 20KHE
1	48017	Key Switch	x
2	48297	Fuse Holder	x
2a	48298	Fuse 20 Amps	x
3	48016	Solenoid	x
4	48015	Battery may be purchased locally (U9-LM)	x
5	48496	Wiring Harness Complete	x
6	48029-03	Battery Cable - 13-3/4" Red	x
7	48029-01	Battery Cable - 13-3/4" Black	x
8	48126	Rubber Boot	x
9	48021	Switch, Handle Interlock N.C.	x
10	48305	Switch, Cutter Drive Interlock N.C.	x
11	48026	Switch, Neutral Interlock N.C.	x

# WIRING DIAGRAM FOR MANUAL START

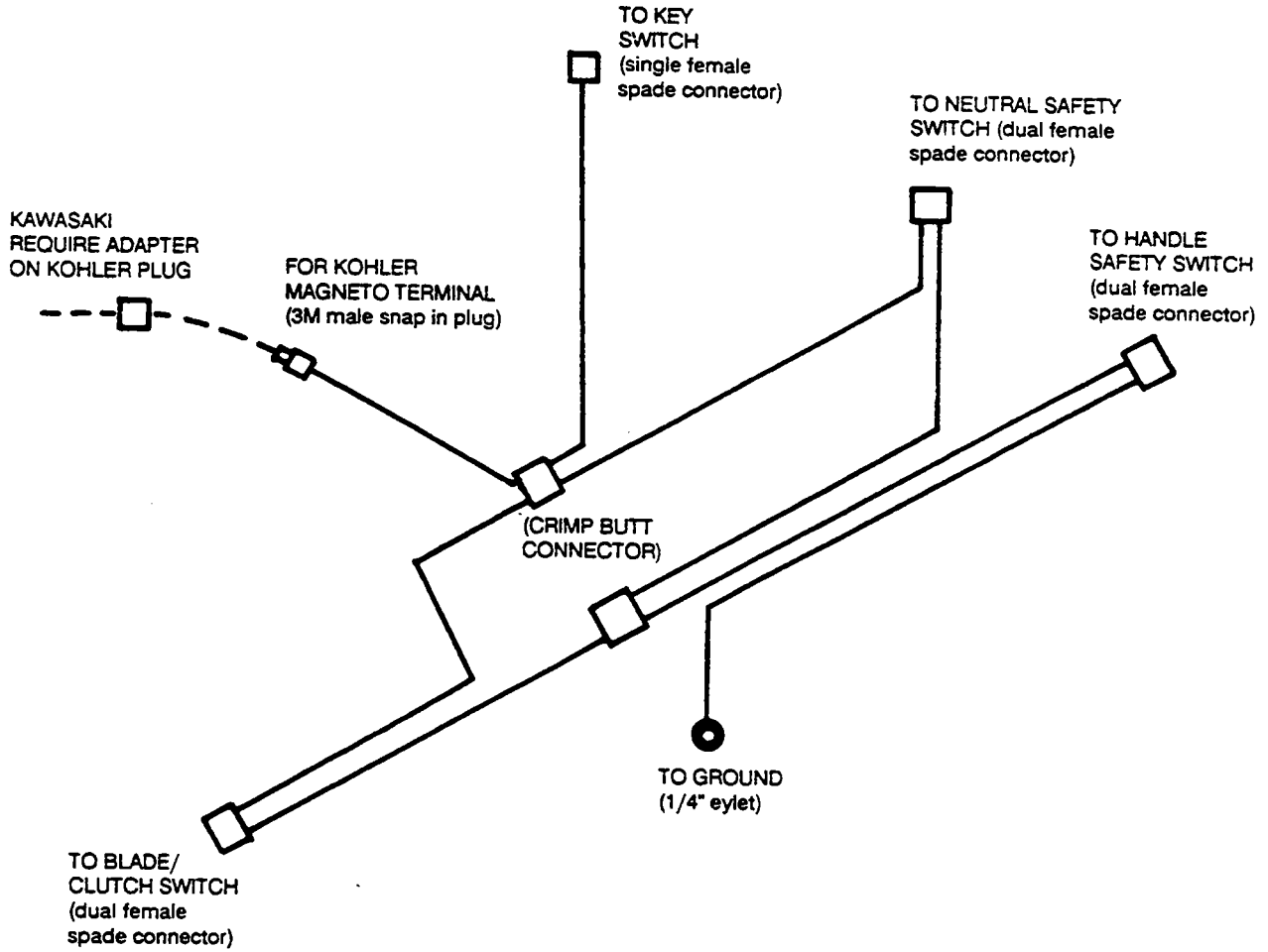

## Free Manuals Download Website

<http://myh66.com>

<http://usermanuals.us>

<http://www.somanuals.com>

<http://www.4manuals.cc>

<http://www.manual-lib.com>

<http://www.404manual.com>

<http://www.luxmanual.com>

<http://aubethermostatmanual.com>

Golf course search by state

<http://golfingnear.com>

Email search by domain

<http://emailbydomain.com>

Auto manuals search

<http://auto.somanuals.com>

TV manuals search

<http://tv.somanuals.com>