

# Advantys FTB CANopen IP67 monobloc input/output splitter box User guide

1606218 02 eng 3.0





---

# Table of Contents



---

	<b>Safety Information</b> .....	<b>7</b>
	<b>About the Book</b> .....	<b>9</b>
<b>Chapter 1</b>	<b>Introduction</b> .....	<b>11</b>
	Presentation .....	11
	Presentation of the CANopen Advantys FTB I/O Splitter Box Range .....	12
	Overview of the Accessories Range .....	13
<b>Chapter 2</b>	<b>Installation</b> .....	<b>15</b>
	Presentation .....	15
	Overview .....	16
	Installing the Unit .....	17
	Grounding of the Advantys FTB Splitter Box .....	21
	EMC Compatibility .....	23
<b>Chapter 3</b>	<b>Splitter Box Characteristics and Wiring</b> .....	<b>27</b>
	Presentation .....	27
	Advantys FTB Splitter Box Environment Properties .....	28
	Electrical Characteristics .....	29
	Connecting the Actuators and Sensors .....	30
	Power Supply Connection .....	32
<b>Chapter 4</b>	<b>CANopen Network Interface</b> .....	<b>35</b>
	Presentation .....	35
4.1	Wiring on the CANopen Bus .....	37
	Presentation .....	37
	Introduction to Wiring on the CANopen Bus .....	38
	Topology .....	39
	Choice of system cables .....	42
	Connecting the Field Bus .....	44
	Configuring the Address and Transmission Speed .....	46
4.2	General Principles .....	48
	Presentation .....	48
	About CANopen .....	49
	The Device Profile .....	52

	CANopen "Boot-Up" . . . . .	53
	Process Data Object (PDO) Transmission . . . . .	56
	Inhibit Time and Event Timer . . . . .	60
	Access to Data by Explicit Exchanges (SDO) . . . . .	61
	"Node-Guarding" and "Life-Guarding" Monitoring Protocols . . . . .	62
	The "Heartbeat" Error Monitoring Protocol . . . . .	65
4.3	Behavior of FTB CANopen Splitter boxes . . . . .	66
	Presentation . . . . .	66
	Behavior at Power-up . . . . .	67
	Behavior in the Case of Communication Error . . . . .	68
	Saving / Restoring Parameters . . . . .	69
	List of Saved Parameters . . . . .	70
<b>Chapter 5</b>	<b>Application-Specific Functions . . . . .</b>	<b>71</b>
	Presentation . . . . .	71
	List of Objects . . . . .	72
	Description of the Discrete Inputs . . . . .	74
	Description of Discrete Outputs . . . . .	75
	Description of Configurable Discrete I/Os . . . . .	76
	List of Advantys FTB 1CN08E08SP0 Splitter Box I/O Objects . . . . .	78
	List of Advantys FTB 1CN12E04SP0 Splitter Box I/O Objects . . . . .	81
	List of Advantys FTB 1CN16EP0 and FTB 1CN16EM0 Splitter Box I/O Objects . . . . .	85
	List of Advantys FTB 1CN16CP0 and FTB 1CN16CM0 Splitter Box I/O Objects . . . . .	87
	List of Advantys FTB 1CN08E08CM0 Splitter Box I/O Objects . . . . .	91
<b>Chapter 6</b>	<b>Software Tools . . . . .</b>	<b>97</b>
	Presentation . . . . .	97
6.1	Introduction to Software Tools . . . . .	99
	Introduction . . . . .	99
6.2	Product Configuration . . . . .	101
	At A Glance . . . . .	101
	Characteristics of an EDS File . . . . .	102
	Existing EDS File for CANopen Advantys FTB Splitter Box . . . . .	103
	Creating a New EDS and DCF Configuration File . . . . .	104
6.3	Network Configuration . . . . .	107
	Setting the Network Parameters . . . . .	107
6.4	PLC Programming . . . . .	114
	Presentation . . . . .	114
	Integration and Use under PL7 . . . . .	115
	Examples of SDO Requests . . . . .	120
<b>Chapter 7</b>	<b>Diagnostics . . . . .</b>	<b>123</b>
	Presentation . . . . .	123
	Power Supply Diagnostics . . . . .	124
	Field Bus Status Diagnostics LED . . . . .	125
	LED Status Diagnostics for I/O . . . . .	126

	CANopen Objects Diagnostics .....	127
	Behavior in the Event of Short-circuit / Overload / Under-voltage .....	130
<b>Chapter 8</b>	<b>The Object Dictionary .....</b>	<b>131</b>
	Presentation .....	131
8.1	The Object Dictionary .....	133
	The Object Dictionary .....	133
8.2	Objects of the Communication Profile 1000H to 1FFFH .....	134
	At a Glance .....	134
	Object 1000H: Device Type .....	135
	Object 1001H: Error Register .....	136
	Object 1002H: Manufacturer Status Register .....	137
	Object 1003H: Pre-defined Error Field .....	138
	Object 1005H: COB-ID SYNC Message .....	140
	Object 1006H: Communication Cycle Period .....	141
	Object 1008H: Manufacturer Device Name .....	142
	Object 100AH: Manufacturer Software Version (MSV) .....	143
	Object 100CH: Guard Time .....	144
	Object 100DH: Life Time Factor .....	145
	Object 1010H: Store Parameters .....	146
	Object 1011H: Restore Default Parameters .....	148
	Object 1014H: COB-ID Emergency Message (EMCY) .....	150
	Object 1016H: Consumer Heartbeat Time .....	151
	Object 1017H: Producer Heartbeat Time .....	152
	Object 1018H: Identity Object .....	153
	Object 1200H: Server SDO Parameter .....	154
	Object 1400H: 1st Receive PDO Communication Parameter .....	155
	Object 1405H: 2nd Receive PDO Communication Parameter .....	156
	Object 1600H: 1st Receive PDO Mapping Parameter .....	157
	Object 1605H: 2nd Receive PDO Mapping Parameter .....	159
	Object 1800H: 1st Transmit PDO Communication Parameter .....	161
	Object 1805H: 2nd Transmit PDO Communication Parameter .....	164
	Object 1A00H: 1st Transmit PDO Mapping Parameter .....	167
	Object 1A05H: 2nd Transmit PDO Mapping Parameter .....	169
8.3	Manufacturer-specific Zone Objects 2000H to 5FFFH .....	171
	At a Glance .....	171
	Object 2000H: Input / Diag Parameter .....	172
	Object 2001H: Input/Output Parameter .....	173
	Object 3000H: Manufacturer Specific Diagnostic .....	174
8.4	Hardware Profile Objects 6000H to 9FFFH .....	175
	At a Glance .....	175
	Object 6000H: Read Inputs 8 Bits .....	176
	Object 6100H: Read Input 16 Bits .....	177
	Object 6102H: Polarity Input .....	178
	Object 6103H: Filter Constant Input 16 Bits .....	179
	Object 6200H: Write Outputs 8 Bits .....	180

---

Object 6300H: Write Outputs 16 Bits . . . . .	181
Object 6302H: Polarity Outputs 16 Bits . . . . .	182
Object 6306H: Fallback Mode 16 Bits . . . . .	183
Object 6307H: Fallback Value 16 Bits . . . . .	184
Object 6308H: Filter Mask Output 16 Bits . . . . .	185
<b>Appendices . . . . .</b>	<b>187</b>
At a Glance . . . . .	187
<b>Appendix A IEC Symbols . . . . .</b>	<b>189</b>
Glossary of Symbols . . . . .	189
<b>Glossary . . . . .</b>	<b>191</b>
<b>Index . . . . .</b>	<b>197</b>

---

# Safety Information

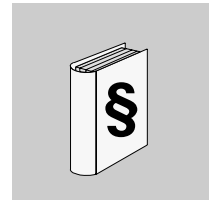

---

## Important Information

### NOTICE

Read these instructions carefully, and look at the equipment to become familiar with the device before trying to install, operate, or maintain it. The following special messages may appear throughout this documentation or on the equipment to warn of potential hazards or to call attention to information that clarifies or simplifies a procedure.



The addition of this symbol to a Danger or Warning safety label indicates that an electrical hazard exists, which will result in personal injury if the instructions are not followed.



This is the safety alert symbol. It is used to alert you to potential personal injury hazards. Obey all safety messages that follow this symbol to avoid possible injury or death.

## DANGER

DANGER indicates an imminently hazardous situation, which, if not avoided, **will result** in death or serious injury.

## WARNING

WARNING indicates a potentially hazardous situation, which, if not avoided, **can result** in death, serious injury, or equipment damage.

## CAUTION

CAUTION indicates a potentially hazardous situation, which, if not avoided, **can result** in injury or equipment damage.

**PLEASE NOTE**

Electrical equipment should be installed, operated, serviced, and maintained only by qualified personnel. No responsibility is assumed by Schneider Electric for any consequences arising out of the use of this material.

© 2006 Schneider Electric. All Rights Reserved.

---



---

## About the Book

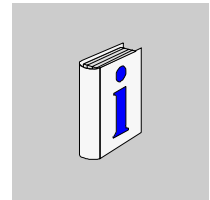

---

### At a Glance

**Document Scope** This user guide contains the information required to install an Advantys FTB CANopen monobloc IP67 splitter box.

It has been designed to facilitate rapid familiarization with the system, while optimizing the system's features for the most advanced technology available.

To install Advantys FTB CANopen splitter boxes, the relevant communication protocol pre-requisites are necessary, and it should only be installed by qualified personnel. Special points and warnings regarding safety are highlighted in the different chapters.

The early chapters provide information for designers and installers on installing the mechanical and electrical elements of the system.

The following chapters, from the section on "network interface", are specific to the communication protocol. They contain information on specific wiring for the network interface and all the necessary information for the software application programmer, and for the end user (diagnostics).

<b>Chapter</b>	<b>Subject covered</b>
Introduction	General presentation of system components
Installation	Dimensions Safe practice for installation
I/O splitter box characteristics and wiring	Physical and electrical characteristics Wiring information
CANopen network interface	Wiring the splitter box on the network Reminder on the communication protocol System behavior
Application functions	Description of application functions (Advantys FTB CANopen splitter box I/O functions)
Software implementation	Software installation help
Diagnostics	Performing diagnostics
Object dictionary	Description of the objects accessible for communication
Appendices	Presentation Appendix A: List of IEC symbols
Glossary	Acronyms Definitions

### Related Documents

<b>Title of Documentation</b>	<b>Reference Number</b>
Instruction sheet	1693627
CANopen hardware installation manual	35010859

### User Comments

We welcome your comments about this document. You can reach us by e-mail at [techpub@schneider-electric.com](mailto:techpub@schneider-electric.com)

---

---

# Introduction



---

## Presentation

### Introduction

This chapter provides a general overview of Advantys IP 67 FTB CANopen IP67 I/O splitter boxes.

Advantys FTB CANopen splitter boxes comply with the following specifications:

- CiA DS301 V4.02 (CANopen application layer and communication profile)
- CiA DS401 V2.1 (CANopen device profile generic I/O modules) (see *CANopen Profiles*, p. 50)

**Note:** The information in this manual is primarily intended for people with some practical knowledge of the CANopen standard applied to the CANopen field bus. CANopen equipment installers and users are advised to read the standard documentation before any equipment installation or handling. All detailed CANopen specifications may be found at <http://www.can-cia.de>.

### What's in this Chapter?

This chapter contains the following topics:

Topic	Page
Presentation of the CANopen Advantys FTB I/O Splitter Box Range	12
Overview of the Accessories Range	13

## Presentation of the CANopen Advantys FTB I/O Splitter Box Range

### The CANopen Advantys FTB Product Range

The splitter boxes in the CANopen Advantys FTB ranges come in the following forms:

- CANopen plastic unit
- CANopen metal unit

### Configurable Connectors

Each CANopen Advantys FTB splitter box contains eight connectors used to link the sensors or actuators.

Each of these connectors supports two channels. Depending on the splitter box reference, and on its configuration, each channel is either:

- an input channel,
- an output channel,
- a DESINA standard diagnostics channel.

### Splitter Box Inputs and Outputs

The configuration of the I/O connector channels depends on the splitter box model. The table below shows the I/O connector channels available for each model:

Distribution of available inputs/outputs	Unit type	Product reference
8 input / diagnostics channels + 8 output channels	Plastic	FTB 1CN08E08SP0
4 input channels + 4 output channels + 8 input / diagnostics channels	Plastic	FTB 1CN12E04SP0
8 input channels + 8 input / diagnostics channels	<ul style="list-style-type: none"> <li>● Plastic</li> <li>● Metal</li> </ul>	FTB 1CN16EP0 FTB 1CN16EM0
8 input / output channels + 8 input / output / diagnostics channels	<ul style="list-style-type: none"> <li>● Plastic</li> <li>● Metal</li> </ul>	FTB 1CN16CP0 FTB 1CN16CM0
8 input / output channels + 8 input / diagnostics channels	Metal	FTB 1CN08E08CM0

## Overview of the Accessories Range

### Cables for Connecting the Bus to the Splitter Box

Different cables can be used to connect the splitter box to the field bus. These are available in different lengths.

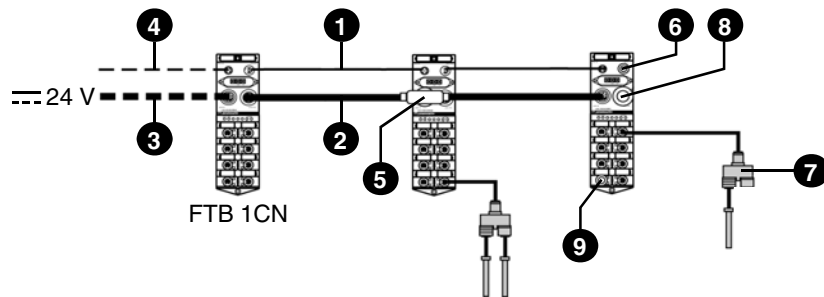

Element	Reference	Function
1	FTX CN3203 FTX CN3206 FTX CN3210 FTX CN3220 FTX CN3230 FTX CN3250	Cables fitted with 2 M12-type elbow connectors, 5 pins, at both ends for connecting the bus between two splitter boxes.
2	FTX DP2206 FTX DP2210 FTX DP2220 FTX DP2250	Cables fitted with 2 7/8-type connectors, 5 pins, at both ends for daisy-chaining 24 VDC supplies to two splitter boxes.
3	FTX DP2115 FTX DP2130 FTX DP2150	Cables fitted with 1 7/8-type connector, 5 pins, with one free end and the other for connecting 24 VDC supplies.
4	FTXCN12M5 FTXCN12F5	Male and female M12-type connectors, 5 pins, for CANopen bus cables (encoding A).
5	FTXCNCT1	Connection T fitted with 2 7/8-type connectors, 5 pins, for power supply cables.
6	FTX CNTL12	Line terminators fitted with 1 M12-type connector.
7	FTX CY1208 FTX CY1212	Distribution Y for connecting 2 M8-type connectors to the M12 connector of the splitter box. Distribution Y for connecting 2 M12-type connectors to the M12 connector of the splitter box.
8	FTX C78B	Sealing plug for 7/8 connector.
9	FTX CM12B	Sealing plugs for M12-type connectors.



---

# Installation



# 2

---

## Presentation

### Introduction

This chapter provides all required information for installing an FTB splitter box on a field bus.

**Note:** The graphic representations of the splitter boxes in this chapter may not correspond to those really used. However, the dimensions are exact whatever the case.

### What's in this Chapter?

This chapter contains the following topics:

Topic	Page
Overview	16
Installing the Unit	17
Grounding of the Advantys FTB Splitter Box	21
EMC Compatibility	23

## Overview

### Introduction

This section gives a detailed technical description of the Advantys FTB CANopen splitter box.

### Description

The illustrations below show the plastic units (left) and metal units (right) of the Advantys FTB CANopen splitter.

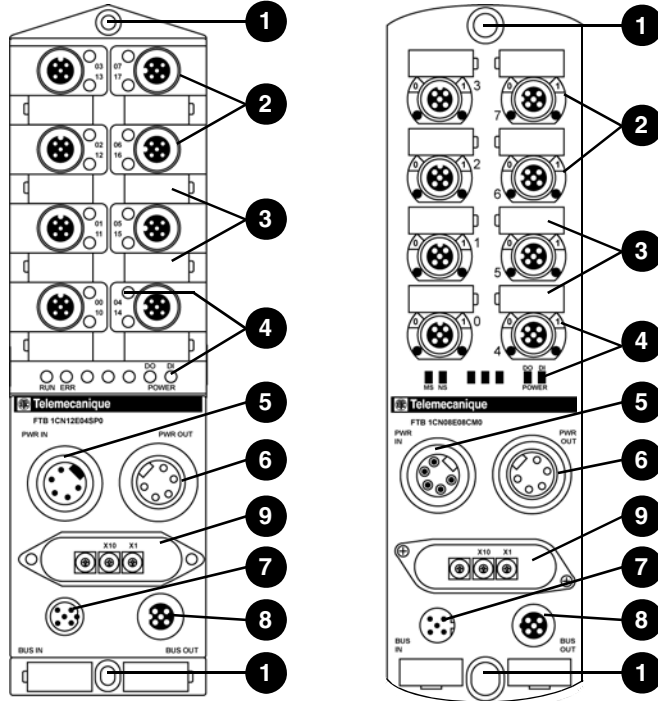

Element	Function
1	Mounting holes
2	M12 connector for the inputs and outputs
3	Label
4	Display elements (diagnostics and status LED)
5	Power supply connectors (PWR IN)
6	Power supply distribution connector (PWR OUT)
7	Bus connector (BUS IN)
8	Bus connector (BUS OUT)
9	Transmission speed and addressing rotary selector switch



---

## Installing the Unit

---

**Introduction** This section gives a detailed technical description of Advantys FTB splitter boxes.

---

**Description** The Advantys FTB splitter box can be mounted directly onto a wall or a machine. Two mounting holes have been provided for this purpose inside the splitter box.

**Note:** When mounting the unit, the support must be flat and smooth so as to prevent any undue stress on the unit, which may lead to a loss of sealing.

---

**Types of Screws  
and Tightening  
Torques**

***Plastic unit***

The plastic splitter box is mounted using two 4 mm (*0.16 in.*) diameter screws and two washers. The tightening torque is 1.5 Nm (*13.3 lb-in*).

***Metal unit***

The metal splitter box is mounted using two 6 mm (*0.24 in.*) diameter screws and two washers. The tightening torque is 9 Nm (*79.7 lb-in*).

**Note:** For metal units, wire the ground terminal before attaching the splitter box to its support. See *Grounding of the Advantys FTB Splitter Box*, p. 21.

---

**Plastic Unit Dimensions**

The dimensions of the plastic unit (front and side views) are given in the following illustrations:

mm  
inch

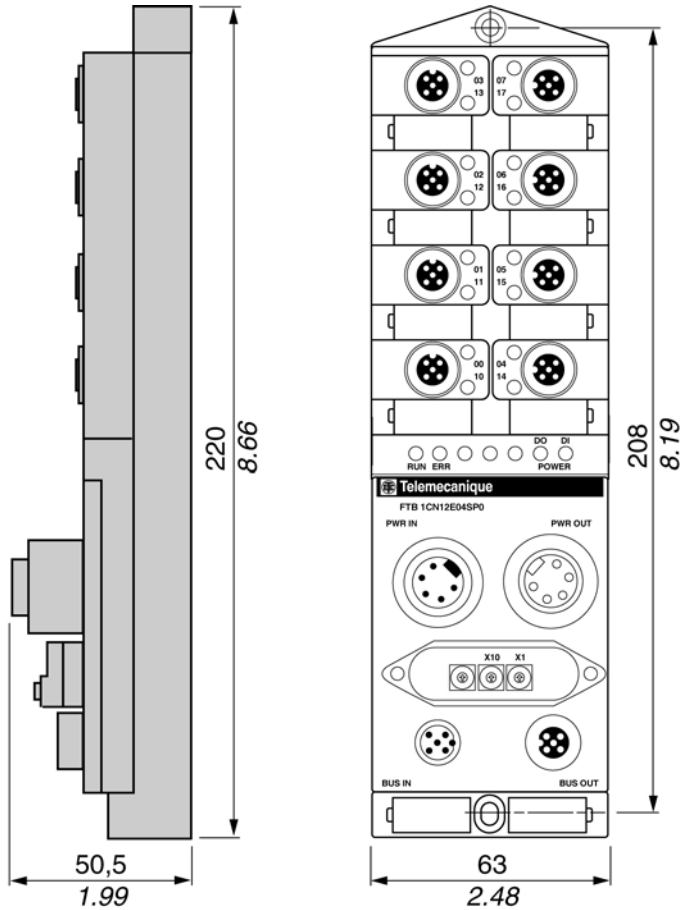

**Metal Unit  
Dimensions**

The dimensions of the metal unit (front and side views) are given in the following illustrations:

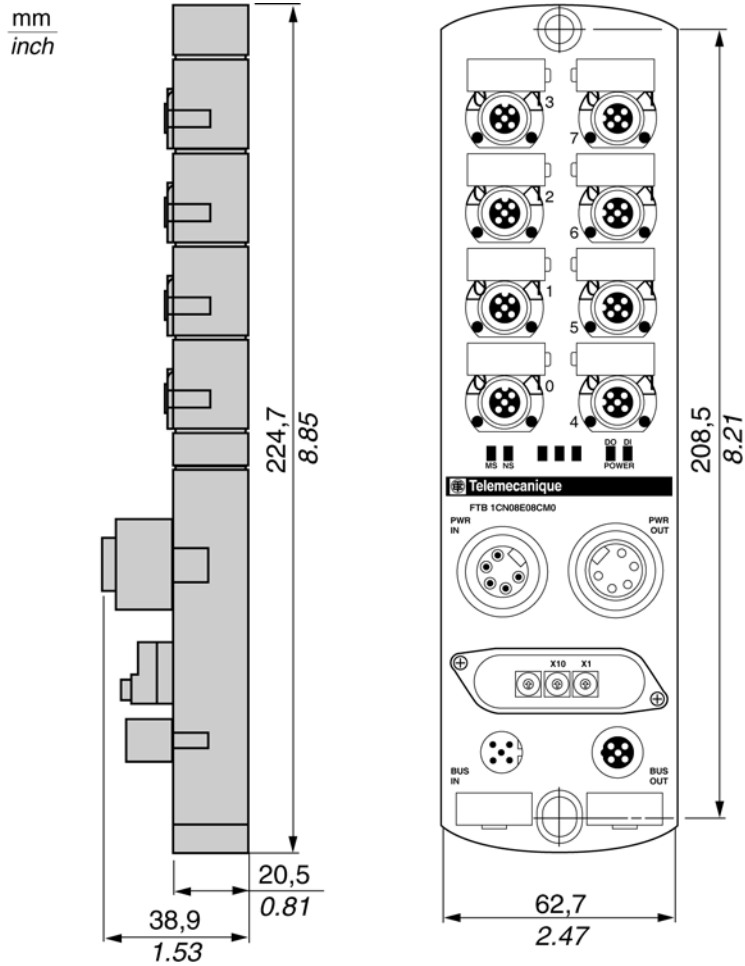

**Method**

Follow the steps below:

Step	Action
1	Position the splitter box on the support.
2	Mount the splitter box using the screws and washers.

** CAUTION****RISK OF EQUIPMENT DAMAGE AND NON-COMPLIANCE WITH IP67.**

Unused connectors must not be left unprotected. If a connector is not correctly connected to the end of another connector or to a standard cable, fit a sealing plug in order to ensure that the product is IP67 standard compliant. To ensure the IP67 protection index, check that the cover is screwed onto the base splitter box and that all connectors are fitted with cables or sealing plugs.

**Failure to follow this instruction can result in injury or equipment damage.**

---

## Grounding of the Advantys FTB Splitter Box

### Description

The ground connection is connected internally to pin 1 of the M12 connector of the field bus connector.

### **⚠ WARNING**

#### **RISK OF UNINTENDED EQUIPMENT OPERATION**

Check that the splitter box is correctly connected to the earth in compliance with the instructions provided in this section. If the splitter box is not grounded, or if the ground connection is made with an unsuitable cable, the product will be sensitive to electromagnetic disturbances. See *EMC Compatibility, p. 23*.

**Failure to follow this instruction can result in death, serious injury, or equipment damage.**

### Position of the Ground Electrode on the Plastic Unit

The following figure shows the position of the ground electrode on the plastic boxes.

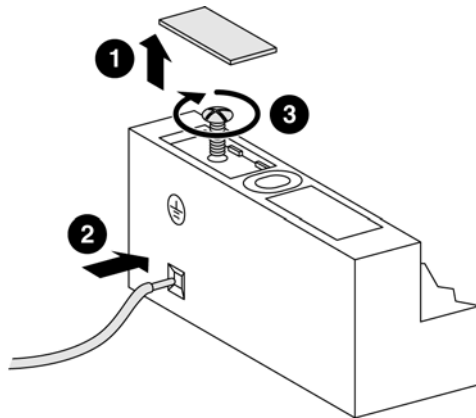

**Note:** Use a grounding strip or a conductor with a cross-section of 1 to 1.5 mm<sup>2</sup> (AWG18, AWG16) and a length of ≤ 3 m (9.84 ft) long. The maximum recommended length for the grounding strip is 3 m (9.84 ft).

**Method for Plastic Units**

Follow the steps below to connect the ground to the unit:

Step	Action
1	Remove the label located above the symbol representing the ground.
2	Insert the end of the grounding strip into the grounding terminal of the splitter box.
3	Screw in the ground connection screw.

**Position of the Ground Electrode on the Metal Unit**

The following figure shows the position of the ground electrode on the metal boxes.

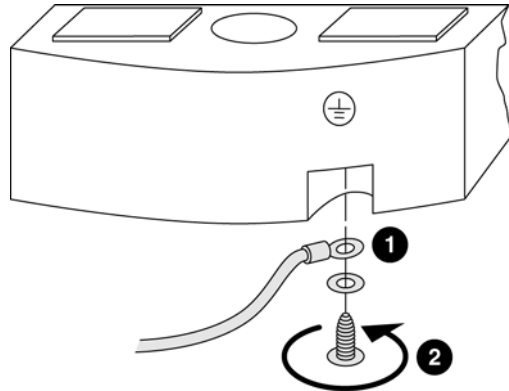

**Note:** Use a grounding strip or a conductor with a cross-section of 1 to 1.5 mm<sup>2</sup> (AWG18, AWG16) and a length of ≤ 3 m (9.84 ft) long. The maximum recommended length for the grounding strip is 3 m (9.84 ft).

**Method for Metal Units**

Follow the steps below to connect the unit to the ground electrode:

Step	Action
1	Crimp the lug on the ground cable.
2	Screw in the lug with the ground conductor connection screw (supplied with the product).

**Mounting the Metal Unit**

Once these steps have all been completed (see table above), the product can be mounted on its support.

## EMC Compatibility

### Product Compliance



This product complies with the European directive 89/336/CEE on "electromagnetic compatibility".

The products described in this manual meet all the conditions regarding electromagnetic compatibility and are compliant with the applicable standards. However, this does not mean that the electromagnetic compatibility of your installation is assured.

This is why it is strongly recommended to follow all indications concerning an EMC compliant installation. Only in these conditions and thanks to the exclusive use of CE approved components, will the devices used be deemed as compliant with the EMC directives.

When handling the products, ensure that all safety measures related to electromagnetic compatibility and all conditions for the use of the products are complied with by all persons concerned. This is especially important when handling products sensitive to electrostatic discharges.

### **WARNING**

#### **RISK OF ELECTROMAGNETIC INTERFERENCE AND UNINTENDED EQUIPMENT OPERATION**

The products described in this manual contain highly complex semiconductors that can be damaged or destroyed by electrostatic discharges (ESD). If, for example, they are used within the vicinity of devices rated as class A or B according to IEC 6100-4-4, the level of electromagnetic interference may be enough to cause the device to operate unexpectedly, and/or to damage it.

Damage may not necessarily cause a failure or malfunction that is immediately detectable. It may occur sporadically or in a delayed manner.

If there is a risk of electromagnetic interference, the system designer must implement the necessary protective measures.

**Failure to follow this instruction can result in death, serious injury, or equipment damage.**

## Grounding

A low impedance connection with a maximum length of 3 m (*9.84 ft*) must be installed between the splitter box's ground electrode and the reference ground in order to discharge the noise voltages. The inductance of standard grounding cables (PE) presents a risk of high impedance when high frequency noise voltages are present. It is therefore advisable to use grounding strips. If this solution is not possible, use a ground conductor with a large cable cross-section and a ground connection that is as short as possible.

### **WARNING**

#### **RISK OF UNINTENDED EQUIPMENT OPERATION**

If the box is not connected to the ground, or if the ground connection is made using an inappropriate cable, the product will be sensitive to electromagnetic disturbances. This may lead to unexpected equipment operation.

**Failure to follow this instruction can result in death, serious injury, or equipment damage.**

---

## Cable Routing

Make sure that the following basic wiring rules are followed:

- Keep the data wire and the power cables apart from one another, in so far as is possible.
- Make sure there is a space of at least 10 cm (*3.94 inches*) between the data wires and the power cables.
- The data wires and power cables must only cross at a right angle to one another.
- It is advisable to route the data wires and power cables through separate shielded ducts.
- When laying the cables, the noise voltage from other devices or wires must be considered. This particularly applies to frequency converters, motors and other devices or cables generating high frequency disturbances. High frequency sources and the cables described in this manual must be as far apart from each other as possible.

### **WARNING**

#### **RISK OF UNINTENDED EQUIPMENT OPERATION**

Please read and comply with the cabling rules listed above. Failure to comply with these wiring rules is a common cause of EMC problems! This may lead to unexpected equipment operation.

**Failure to follow this instruction can result in death, serious injury, or equipment damage.**

---



**Control of Inductive Loads**

The outputs of the devices described in this manual are equipped with an integrated protective system against the high noise voltages that may be generated by inductive loads.

Integrated protective system against the high noise voltages generated by inductive loads



The varistor rapidly discharges the energy accumulated in the magnetic field of the inductive load.

The high voltages arising from the disconnection of inductive loads create large fields in the wires that may cause disturbances in nearby circuits or devices. It is advisable to provide an anti-interference device at the load level. In this way, the voltage peak generated by the inductive load is short-circuited directly at the point at which it occurs.



---

# Splitter Box Characteristics and Wiring

# 3

---

## Presentation

### Introduction

This chapter provides an overall description of all Advantys FTB splitter boxes.

**Note:** The "-" in the tables corresponds to values that are not applicable.

### What's in this Chapter?

This chapter contains the following topics:

Topic	Page
Advantys FTB Splitter Box Environment Properties	28
Electrical Characteristics	29
Connecting the Actuators and Sensors	30
Power Supply Connection	32

## Advantys FTB Splitter Box Environment Properties

### Environment Properties

Characteristic	Description	Reference standard
Product certification	cULus	-
Operating temperature	-20°C...+60°C (-4°F...+140°F)	-
Storage temperature	-25°C...+70°C (-13°F...+158°F)	-
Degree of protection	IP67	According to IEC 60529
Altitude	0m 2,000 m (6,561 ft)	-
Vibration withstand capacity for plastic units	<ul style="list-style-type: none"> <li>● Constant amplitude: 0.35 mm (0.0138 in) 10 Hz ≤ f ≤ 57 Hz</li> <li>● Constant acceleration: 5.0 gn 57 Hz ≤ f ≤ 150 Hz</li> </ul>	According to IEC 68-2-6, Fc test
Vibration resistance capacity for metal units	<ul style="list-style-type: none"> <li>● Constant amplitude: 1.5 mm (0.06 in) 5 Hz ≤ f ≤ 70 Hz</li> <li>● Constant acceleration: 15 gn 70 Hz ≤ f ≤ 500 Hz</li> </ul>	According to IEC 68-2-6, Fc test
Shock resistance capacity for plastic units	30 gn, duration: 11 ms	According to IEC 68-2-27, Fc test
Shock withstand capacity for metal units	50 gn, duration: 11 ms	-
Resistance capacity for electrostatic discharges	<ul style="list-style-type: none"> <li>● Contact: +/- 4 kV</li> <li>● Air: +/- 8kV</li> </ul>	According to IEC 61000-4-2
Withstand capacity for radiated fields	10 V/m (3.05 V/ft)	According to IEC 61000-4-3
Withstand capacity for fast transients	<ul style="list-style-type: none"> <li>● Power supply: +/- 2 kV</li> <li>● Signal: +/- 2 kV</li> </ul>	According to IEC 61000-4-4
Withstand capacity for surge	<ul style="list-style-type: none"> <li>● Power supply:                             <ul style="list-style-type: none"> <li>● symmetrical: +/-500VDC</li> <li>● asymmetrical: +/-1,000 VDC</li> </ul> </li> <li>● Signals:                             <ul style="list-style-type: none"> <li>● symmetrical: +/-500VDC</li> <li>● asymmetrical: +/-1,000 VDC</li> </ul> </li> <li>● Ground : +/-500VDC</li> </ul>	According to IEC 61000-4-5
Withstand capacity for duct fields	10 Vrms	According to IEC 61000-4-6
Withstand capacity for 50 Hz magnetic fields	30 A/m (9.15 A/ft)	According to IEC 61000-4-8
Mounting	In all positions	-

## Electrical Characteristics

### Splitter Box Characteristics

Characteristic	Description
Splitter box's internal consumption	120 mA
Splitter power supply voltage	18...30VDC
Splitter and sensor supply current	≤ 8 A
Actuator supply current	≤ 8 A
Under-voltage detection	yes

### Input Characteristics

Characteristic	Description
Compliance with IEC 1131-2	Type 2
Compliance with 2-wire/3-wire sensor	Yes
Rated power voltage	24 VDC
Maximum current	200 mA (for 2 diagnostics input channels)
Logic	Positive PNP Sink
Filtering input	1 ms
Protection against reverse polarity and short-circuit in sensor power supply	Yes
Overload and over-voltage protection	Yes

### Output characteristics

Characteristic	Description
Output type	Transistors
Output voltage	24 VDC
Output current	1.6 A
Over-voltage protection	Yes (transient diode)
Maximum switching cycle	20 Hz
Maximum lamp load	10 W
Connection for outputs / cable lengths	<ul style="list-style-type: none"> <li>● 0.75mm<sup>2</sup>: 10 m maximum (AWG 19 / 32.8 ft)</li> <li>● 0.34 mm<sup>2</sup>: 5 m maximum (AWG 23 / 16.4 ft)</li> </ul>
Protection against short-circuits	yes

## Connecting the Actuators and Sensors

### Description

The actuators and sensors are connected to the FTB splitter box using M12-type connectors.

### Characteristics of the Connections

The maximum admissible load for the FTB splitter boxes is limited to:

- 1.6 A per output (actuator current),
- 200 mA for both inputs (sensor current).

**⚠ WARNING**

**RISK OF EQUIPMENT DAMAGE AND NON-COMPLIANCE WITH IP67**  
 Unused M12 connectors must not be left unprotected. If an M12 connector is not correctly connected to the end of another connector or standard cable, fit a sealing plug in order to ensure that the product is IP67 standard compliant. To ensure the IP67 protection index, check that the cover is screwed onto the base splitter box and that all connectors are fitted with cables or sealing plugs.  
**Failure to follow this instruction can result in death, serious injury, or equipment damage.**

### Assignment of M12 Connector Pins

The following diagram shows the front view of a 5-pin M12 connector and the convention for numbering the pins:



Pin	Assignment
1	+24 VDC
2	Channel 10 to 17: diagnostics input or functional input or output
3	0 VDC
4	Channel 00 to 07: functional input or output
5	Ground

**Allocation of the M12 Connectors to the I/Os**

The following table shows the assignment of the M12 connector pins to the marking of the splitter box's Inputs, Outputs and diagnostics:

<b>Connector number</b>	<b>Pin 4</b>	<b>Pin 2</b>
0	Channel 00	Channel 10
1	Channel 01	Channel 11
2	Channel 02	Channel 12
3	Channel 03	Channel 13
4	Channel 04	Channel 14
5	Channel 05	Channel 15
6	Channel 06	Channel 16
7	Channel 07	Channel 17

## Power Supply Connection

### Description

For the FTB splitter boxes, the power supply is linked using a Mini-Style 7/8" 5-pole connector.

The FTB splitter boxes require a 24 VDC power supply.

### Calculation of the Power Supply Cable Cross-Section

Calculations to find cable cross-sections are made according to the system's own configuration data and remain the full responsibility of the user.

## ⚠ CAUTION

### RISK OF EQUIPMENT DAMAGE

There are two kinds of risk of damage to equipment:

- The 7/8" connector is sized for a maximum current of 8 A per pin. The pins of the 7/8" connector must be provided with adequate protection to prevent an overload of more than 8 A.
- Reversed polarity connections in the power supply may damage the FTB splitter box.

**Failure to follow this instruction can result in injury or equipment damage.**

### Assembling the Power Supply Cable

The following diagram gives a view of the shape and size of the connection cable connector:

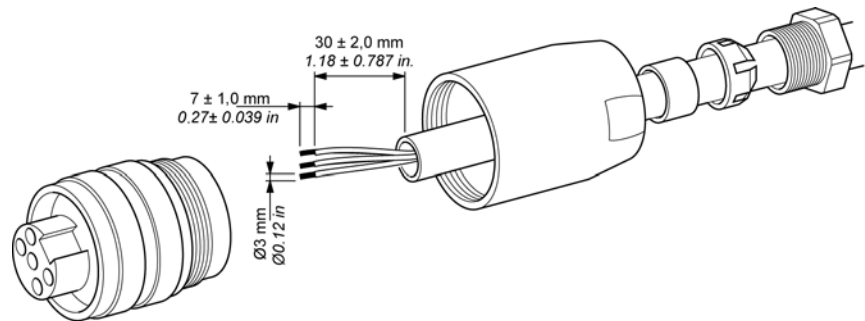



**Pin Assignment**

The following diagram shows a front view of the PWR IN and PWR OUT connectors:

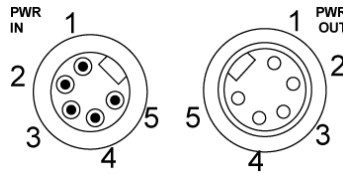

Pin	Assignment
1	0 VDC
2	0 VDC
3	Ground
4	Splitter box sensor and power supply
5	Actuator power supply

**Recommendations for the Power Supply to the Sensors, Actuators and Splitter Boxes**

We recommend the use of 2 independent power supplies so as to separate the power supply to the splitter boxes / sensors from the power supply to the actuators. This configuration provides maximum protection against any disturbance on the outputs (short circuits).

**Emergency Stop**

Separating the splitter box/sensor (pin 4) power supplies means that the emergency stop can be connected to the actuator power supply (pin 5 of the 7/8" connector).

⚠ WARNING
RISK OF UNINTENDED EQUIPMENT OPERATION
Do not connect pin 4 of the power supply connector to the emergency stop circuit of the system. Interrupting the power supply to this pin, will deactivate the I/O channels of the splitter box, which can result in an unintended equipment operation.
<b>Failure to follow this instruction can result in death, serious injury, or equipment damage.</b>

**Method**

Follow the steps below:

Step	Action
1	Disconnect all power to the system.
2	<b>On the PWR IN connector:</b> If the splitter box is the first in the chain, connect a cable with a female connector and free wires. If the splitter box is the last in the chain, connect a connection cable.
3	<b>On the PWR OUT connector:</b> If the splitter box is in the middle of the chain, connect a power supply connection cable. If the splitter box is at the end of the chain, fit a sealing plug.

**Phaseo Power Supply**

A switch mode power supply such as Phaseo (ABL 7●●●) is particularly well-suited to supply automation systems. It is therefore highly recommended for use with Advantys FTB splitter boxes.

---

---

# CANopen Network Interface

# 4

---

## Presentation

### Introduction

This section describes how to connect the Advantys FTB CANopen splitter box to the CANopen network.

### What's in this Chapter?

This chapter contains the following sections:

Section	Topic	Page
4.1	Wiring on the CANopen Bus	37
4.2	General Principles	48
4.3	Behavior of FTB CANopen Splitter boxes	66

---



---

## 4.1 Wiring on the CANopen Bus

---

### Presentation

---

**Introduction** The following section describes wiring on the CANopen bus.

---

**What's in this Section?** This section contains the following topics:

Topic	Page
Introduction to Wiring on the CANopen Bus	38
Topology	39
Choice of system cables	42
Connecting the Field Bus	44
Configuring the Address and Transmission Speed	46

---

## Introduction to Wiring on the CANopen Bus

### Introduction

The physical characteristics necessary for CANopen bus operation are given in the following illustration (plastic units on the left and metal units on the right):

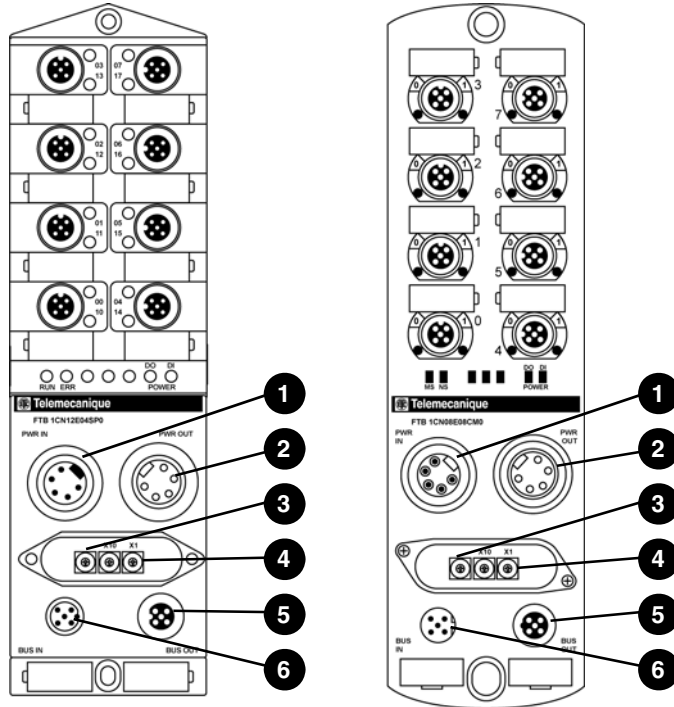

Description	Function	See	
1	7/8" connector	Power supply connection (PWR IN)	<i>Power Supply Connection, p. 32</i>
2	7/8" connector	Power supply connection (PWR OUT)	
3	Rotary switch	Selecting transmission speed	<i>Configuring the Address and Transmission Speed, p. 46</i>
4	Rotary switches	Selecting the splitter box address	
5	M12 Connector	CANopen bus connector (Bus OUT)	<i>Connecting the Field Bus, p. 44</i>
6	M12 Connector	CANopen bus connector (Bus IN)	

## Topology

### Architecture

The CANopen network architecture must comply with the following limitations:

- bus length / transmission speed (See *Transmission Speed*, p. 42),
- number of connected devices (See *Number of Connected Devices*, p. 41),
- length of the taps and the space between two taps (See *Tap Length*, p. 40),
- line terminator (See *Line Terminator Resistance*, p. 43).

The connections to the CANopen bus may be of the chaining or tap type.

The following is an illustration of a CANopen network architecture:

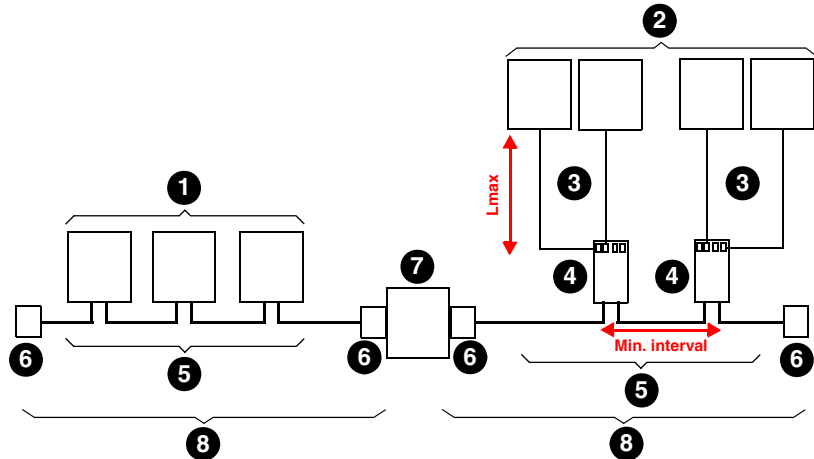

The table below describes the components of a CANopen network:

Number	Description
1	CANopen devices connected by chaining
2	CANopen devices connected by tap
3	Drop cables (tap junction box / device)
4	Tap junction boxes
5	Chaining cables
6	Line terminator
7	Repeater (identical arbitration on the different bus segments) or Bridge (different arbitration on the different bus segments)
8	CANopen bus segment

**Note:** A single line architecture is recommended to reduce signal reflection. Avoid using star-type architecture.

**Tap Length**

A tap creates a signal reflection and thus its length must be limited to the following parameters:

**L<sub>max</sub>** is the maximum length of a tap.

**ΣL<sub>lmax</sub>** is the maximum value of the sum of all taps on the same tap junction box.

**Min interval** is the minimum distance necessary between two taps.

**ΣL<sub>Gmax</sub>** is the maximum value of the sum of all taps on the segment.

The values to use are given in the following table:

Speed	L <sub>max</sub>	ΣL <sub>lmax</sub>	Min. interval 0.6xΣL local	ΣL <sub>Gmax</sub>
1 Mbits/s	0.3 m (0.98 ft)	0.6 m (1.96 ft)		1.5 m (4.9 ft)
800 Kbits/s	3 m (9.8 ft)	6 m (19.6 ft)	3.6 m (11.8 ft)(*)	15 m (49 ft)
500 Kbits/s	5 m (16.4 ft)	10 m (32.80 ft)	6 m (19.6 ft)(*)	30 m (98.4 ft)
250 Kbits/s	5 m (16.4 ft)	10 m (32.80 ft)	6 m (19.6 ft)(*)	60 m (196.8 ft)
125 Kbits/s	5 m (16.4 ft)	10 m (32.80 ft)	6 m (19.6 ft)(*)	120 m (393.6 ft)
50 Kbits/s	60 m (196.8 ft)	120 m (393.6 ft)	72 m (236 ft)(*)	300 m (984 ft)
20 Kbits/s	150 m (492 ft)	300 m (984 ft)	180 m (590.5 ft)(*)	750 m (2 460.6 ft)
10 Kbits/s	300 m (984 ft)	600 m (1 968.4 ft)	360 m (1 181 ft)(*)	1 500 m (4 921 ft)
<b>Legend:</b>				
(*) The minimum cable length between two consecutive tap junction boxes must be greater than 60% of the largest of the two sums of the lengths of taps on each of the two boxes.				



**Example**

The following illustration shows the calculation of the length of a cable located between two tap junction boxes.

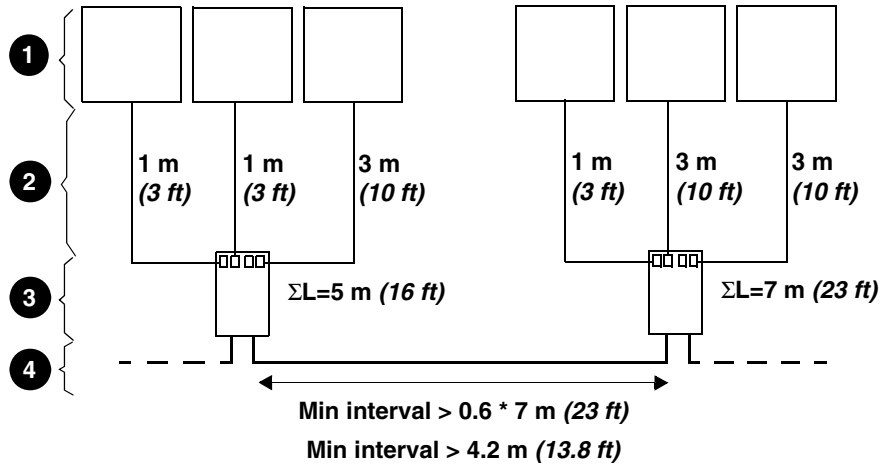

The table below describes the components of a CANopen network:

Number	Description
1	Connected CANopen devices
2	Drop cables (tap junction box / device)
3	Tap junction boxes
4	Connection cables (tap junction box / tap junction box)

In this example, we have two tap junction boxes and 6 devices. We start by calculating the sum of the lengths of cables for each tap junction box, and we obtain 5 m (16 ft) and 7 m (23 ft). We keep the longest length, i.e. 7 m (23 ft). The minimum length of the cable between the two tap junction boxes is equal to 60% of 7 m, i.e. 4.2 m (13.8 ft).

**Number of Connected Devices**

In addition to the length limitations over the whole of the CANopen bus, the following limitations apply:

- Whatever the case, no more than 64 devices may be connected on the same segment.

## Choice of system cables

### Transmission Speed

The maximum allowable transmission speeds are given in the following table:

Transmission speed (kBit/s)	Cable length
1000	30 m (98 ft)
800	50 m (164 ft)
500	100 m (328 ft)
250	250 m (820 ft)
125	350 m (1 148 ft)
100	500 m (1 640 ft)
50	1 000 m (3 280 ft)
20	2 500 m (8 202 ft)
10	5 000 m (16 404 ft)

### Specific Resistance

The specific resistances and AWG cable sections are shown in the following table:

Maximum speed Kbits/s	Cable length		Specific resistance of cables		Cable sections	
	m	ft	mΩ/m	mΩ/ft	mm <sup>2</sup>	AWG
1000 for 40 m (131 ft)	0 ... 40	0...131	70	21.34	0.25...0.34	AWG24, AWG22
500 for 100 m (328 ft)	40 ... 300	131...984	< 60	< 18.29	0.34...0.6	AWG22, AWG20
100 for 500 m (1640 ft)	300 ... 600	984...1968	< 40	< 12.19	0.5...0.6	AWG20
50 for 1000 m (3,280 ft)	600 ... 1000	1968...3280	< 26	< 7.92	0.75...0.8	AWG18

**Note:** The parameters shown in the above table must be considered for networks complying with the standard ISO11898-2.

**Line Terminator Resistance**

To minimize the voltage drop in the connection, it is advisable to use a higher line terminator resistance for high length cables than that specified by the standard ISO11898-2. When configuring the system, the connector resistances must also be taken into consideration. For each connector, 5 m $\Omega$  to 20 m $\Omega$  must be added to the terminator resistance.

** WARNING****RISK OF UNINTENDED EQUIPMENT OPERATION**

The potential difference at the CAN\_GND connections of all the CANopen bus items must not be greater than 2 VDC. The connectors have a standard DC of 5 m $\Omega$  to 20 m $\Omega$ . It is important to connect a 120  $\Omega$  line terminator between CAN\_H and CAN\_L at the line end (see *Physical Layer, p. 49*).

**Failure to follow this instruction can result in death, serious injury, or equipment damage.**

**What types of cables can be used?**

Pre-assembled cables make installing the system considerably easier. Cabling errors are avoided and implementation is achieved more rapidly. Schneider Electric offers a full range of products such as field bus links, power supply cables and cables for detectors, together with accessories such as line terminators. Connectors and cables for assembly are also available.

## Connecting the Field Bus

### Description

The splitter box can either be in the middle of the chain connection or at line end.  
The field bus is connected via a 5-pin M12 connector.

### Illustration of the Connection Cable Connector

The following diagram shows the characteristics of the connection cable connector:

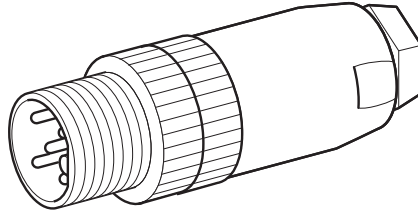

### Bus Connector Pin Assignment

The BUS IN connector is a 5-pin M12 male connector.

The BUS OUT connector is a 5-pin M12 female connector.

The following diagram shows a front view of the bus connectors:

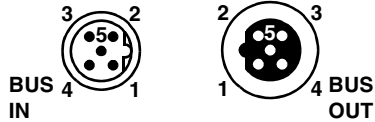

The following table gives the assignments of the bus connector pins:

Pin	Signal	Meaning
1	(CAN_SHLD)	Optional CAN shielding
2	(CAN_V+)	NC (not connected)
3	CAN_GND	0 V
4	CAN_H	CAN_H bus line
5	CAN_L	CAN_L bus line

**Note:** Pin 1 is connected to the ground connection terminal of the splitter box.

**⚠ CAUTION****RISK OF EQUIPMENT DAMAGE AND NON-COMPLIANCE WITH STANDARD IP67**

Unused M12 connectors must not be left unprotected.

If an M12 connector is not fitted with a line terminator or connected to a standard cable, fit a sealing plug so as to guarantee the product's IP67 protection.

**Failure to follow this instruction can result in injury or equipment damage.**

**Correspondence  
between 9-pin  
SUB-D  
Connectors and  
M12 5-pin  
Connectors**

The bus connector on IP20 products is a 9-pin SUB-D connector (e.g. Advantys OTB CANopen).

The following table shows the correspondence between pins on 9-pin SUB-D connectors and on 5-pin M12 connectors:

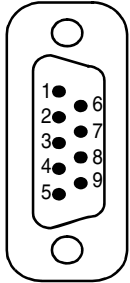
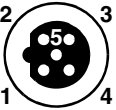
9-pin SUB-D connector	SUB-D pin	Signal	Meaning	M12 pin	5-pin M12 connector
	1	-	Reserved	-	
	2	CAN_L	CAN_L bus line	5	
	3	CAN_GND	0 V	3	
	4	-	Reserved	-	
	5	(CAN_SHLD)	Optional CAN shielding	1	
	6	(GND)	Optional CAN_V-	-	
	7	CAN_H	CAN_H bus line	4	
	8	-	Reserved	-	
	9	(CAN_V+)	Optional power supply	-	

**Method**

Follow the steps below:

Step	Action
1	Connect the connection cable for chaining to the BUS IN connector.
2	If the splitter box is at the end of the line, connect a line terminator resistor to the BUS OUT connector. Otherwise, connect a connection cable to the BUS OUT connector.

## Configuring the Address and Transmission Speed

### Method

Follow the steps below:

Step	Action
1	Switch off the power supply to the splitter box.
2	Unscrew both screws on the transparent cover.
3	Set the communication speed.
4	Set the splitter box address.
5	Screw the transparent cover back on.
6	Power up the splitter box.

### Illustration of the Rotary Switches

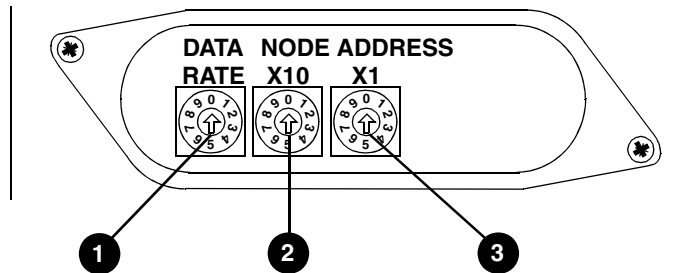

Element	Function
1	Sets the transmission speed
2	Node-ID x 10
3	Node-ID x 1

### Assignment of the Address on the Network

The CANopen address is configured using two specially designed rotary switches. Addresses can be configured from 1 to 99. Address zero (0) cannot be used.

**Note:** When assigning the addresses, ensure that each splitter box is assigned to a single address.  
A configured address is registered at power up. It cannot be changed if you do not remove the cover.

**Adjustment of  
the  
Transmission  
Speed**

The transmission speed is configured using a rotary switch.

The following transmission speeds are possible:

Switch position	Transmission speed
0	Automatic recognition
1	10 Kbits/s
2	20 Kbits/s
3	50 Kbits/s
4	100 Kbits/s
5	125 Kbits/s
6	250 Kbits/s
7	500 Kbits/s
8	800 Kbits/s
9	1 Mbits/s

**Note:** Two different operating modes are possible:

- With a set speed of (10 Kbit/s to 1 Mbits/s), the transmission speed of the splitter box must be the same as that of the other devices on the network.
- In automatic recognition mode, at least one of the slaves on the network must be configured to the speed of the Master.

For each case, if the required condition is not observed, the splitter box will not be recognized by the network ( it will remain in the "Init" state).

## 4.2 General Principles

---

### Presentation

---

**Introduction** This section addresses the general principles for operating and using the CANopen network.

---

**What's in this Section?** This section contains the following topics:

Topic	Page
About CANopen	49
The Device Profile	52
CANopen "Boot-Up"	53
Process Data Object (PDO) Transmission	56
Inhibit Time and Event Timer	60
Access to Data by Explicit Exchanges (SDO)	61
"Node-Guarding" and "Life-Guarding" Monitoring Protocols	62
The "Heartbeat" Error Monitoring Protocol	65

---



---

## About CANopen

---

### Introduction

CANopen is a standard fieldbus protocol for industrial control systems. It is particularly well suited to real-time PLCs, as it provides an effective, low-cost solution for industrial applications.

---

### The CANopen Protocol

The CANopen protocol was created as a subset of CAL (CAN Application Layer). By defining profiles, it is able to be even more specifically adapted to use with standard industrial components. CANopen is a CiA standard (CAN in Automation) that was very quickly adopted by users when it was put on the market. In Europe, CANopen is now recognized as the industry standard for industrial systems based on a CAN design.

---

### Physical Layer

CAN uses a differentially driven two-wire bus line (common return). A CAN signal is the difference between the voltage levels of the CAN\_H and CAN\_L wires. (See figure below.)

The following diagram shows the components of the physical layer of a two-wire CAN bus:

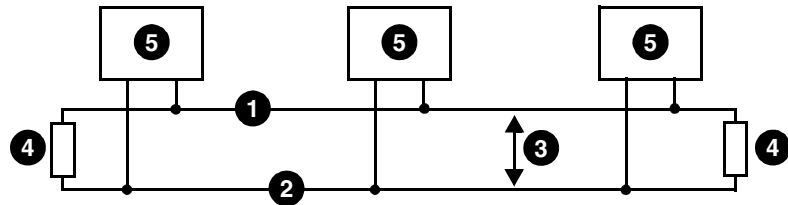

- 1 CAN\_H wire
- 2 CAN\_L wire
- 3 Potential difference between CAN-H/CAN-L signals
- 4 Line terminator 120  $\Omega$
- 5 Connected devices,

The bus wires can be routed in parallel, twisted or shielded form in accordance with electromagnetic compatibility requirements.

---

**CANopen Profiles**

***The communication profile***

The CANopen communication protocol is based on a "communication profile", which specifies the main communication mechanisms and their description (DS301).

***The device profile***

The most important types of devices used in industrial automation are described in the "Device profiles". They also define device functionalities.

Here are some examples of standard devices:

- Discrete and analog input/output splitter boxes (DS401)
  - Motors (DS402)
  - Control devices (DSP403)
  - Closed loop controllers (DSP404)
  - PLCs (DS405)
  - Encoders (DS406)
- 

**Device Configuration via the CAN Bus**

The possibility of configuring devices via the CANopen bus is one of the basic principles of the autonomy required by manufacturers (for each profile family).

---

**General Specifications for CANopen Profiles**

CANopen is a set of profiles for CAN systems with the following specifications:

- An open bus system
  - Real-time data exchange without protocol overload
  - A modular design with the possibility of resizing
  - Interoperability and interchangeability of devices
  - Support guaranteed by a large number of international manufacturers
  - A standardized network configuration
  - Access to all device parameters
  - Synchronization and circulation of cyclical process data and/or event-driven data (possibility of short system response times).
- 

**CANopen Product Certification**

All manufacturers offering CANopen-certified products on the market are members of the CiA (CAN in Automation) industrial consortium. As an active member of the CiA consortium, Schneider Electric develops its products in compliance with standard recommendations recognized internationally by the CiA consortium.

---

**CAN Standards**

CANopen specifications are defined by the CiA group and can be accessed (subject to some restrictions) on the group site at [www.can-cia.de](http://www.can-cia.de). The source codes for master and slave devices are available from the various suppliers.

**Note:** To find out more about CANopen standard specifications and mechanisms, please visit the CiA home page (<http://www.can-cia.de>).

---

**Communication on a CANopen Network**

The communication profile is based on CAL (CAN Application Layer) services and protocols.

It provides the user with access to two types of exchange: SDO and PDO.

On power up, the device enters an initialization phase then goes into "Pre-operational" state. At this stage, only SDO communication is authorized. After receiving a startup command, the device switches to the "Operational" state. PDO and SDO communications are both authorized when the device is in the "Operational" state.

---

## The Device Profile

---

**List of Functions** The list of functions supported and their coding are given in the following table:

Function	Function code (binary)	Resulting COB-ID (Hex)	Resulting COB-ID (Dec)
NMT	0000	0	0
SYNC	0001	80	128
EMERGENCY	0001	81 - FF	129 - 255
TPDO (tx)	0011	181- 1FF	385 - 511
RPDO (rx)	0100	201- 27F	513 - 639
TPDO (tx)	0101	281 - 2FF	641 - 767
RPDO (rx)	0110	301 - 37F	769 - 895
TPDO (tx)	0111	381 - 3FF	897 - 1023
RPDO (rx)	1000	401 - 47F	1025 - 1151
TPDO (tx)	1001	481 - 4FF	1153 - 1279
RPDO (rx)	1010	501 - 57F	1281 - 1407
SDO (tx)	1011	581 - 5FF	1409 - 1535
SDO (rx)	1100	601 - 67F	1537 - 1663
Node-Guarding	1110	701 - 77F	1793 - 1919

---

## CANopen "Boot-Up"

### Procedure for "Boot-Up"

The minimum configuration of the equipment specifies a shortened boot procedure. This procedure is illustrated in the following diagram:

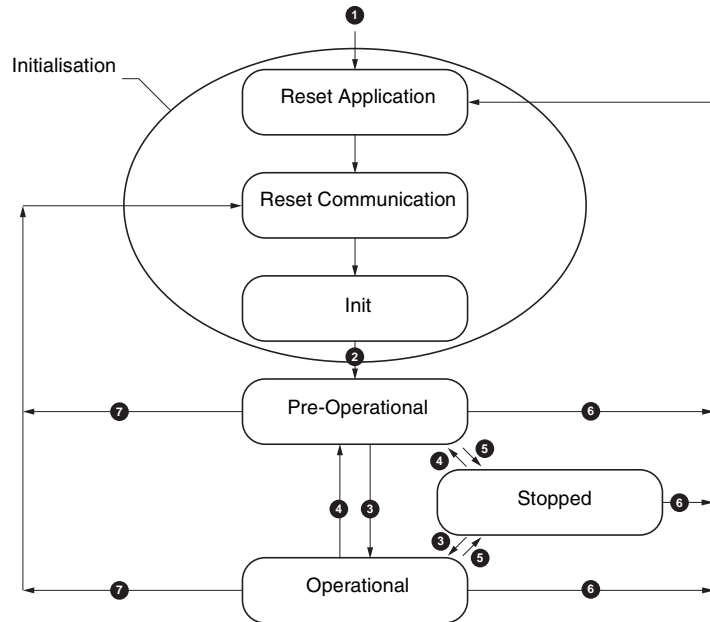

### Legend

Number	Description
1	Device power-up
2	After initialization, the device automatically goes into the PRE-OPERATIONAL state
3	NMT service indication: START REMOTE NODE
4	NMT service indication: ENTER PRE-OPERATIONAL
5	NMT service indication: STOP REMOTE NODE
6	NMT service indication: RESET NODE
7	NMT service indication: RESET COMMUNICATION

NMT : Network Management Telegram

**Active CANopen Objects depending on State Machine**

The crosses in the table below indicate which CANopen objects are active for which states of the state machine:

	Initialisation	Pre-Operational	Operational	Stopped
PDO object:			X	
SDO object:		X	X	
Emergency		X	X	
Boot-Up	X			
NMT		X	X	X

**"Reset Application"**

The device goes into the "Reset Application" state:

- after the device starts up or,
- by "RESET NODE" (NMT service, Network Management Telegram).

In this state, the device profile is initialized, and all the device profile information is reset to default values. When initialization is complete, the device automatically goes into the state "Reset Communication".

**"Reset Communication"**

The device goes into the "Reset Communication" state:

- after the "Reset Application" state,
- by "RESET COMMUNICATION" (NMT service).

In this state, all the parameters (standard value, depending on the device configuration) of the supported communication objects (1000H - 1FFFH) are saved in the object directory. The device then automatically goes into the "Init" state.

**"Init"**

The device goes into "Init" mode after being in the "Reset Communication" state.

This state enables you to:

- define the required communication objects (SDO, PDO, Sync, Emergency),
- install the corresponding CAL services
- configure the CAN-Controller.

Initialization of the device is complete and the device automatically goes into the "Pre-Operational" state and sends a "Boot-Up" message.

**"Pre-Operational"**

The device goes into the "Pre-Operational" state:

- after the "Init" state,
- on receiving the NMT "ENTER PRE-OPERATIONAL" indication if it was in the "Operational" or "Stopped" state.

When the device is in this state, its configuration can be modified. However, only SDOs can be used to read or write device-related data.

When configuration is complete, the device goes into one of the following states on receiving the corresponding indication:

- "Stopped" on receiving the NMT "STOP REMOTE NODE" indication.
- "Operational" on receiving the NMT "START REMOTE NODE" indication.

**"Stopped"**

The device goes into the "Stopped" state on receiving the "STOP REMOTE NODE" indication (NMT service) if it was in "Pre-Operational" or "Operational" state.

In this state, the device cannot be configured. No service is available to read and write device-related data (SDO). Only the slave monitoring function ("Node-Guarding" or "Heartbeat") remains active.

**"Operational"**

The device goes into the "Operational" state if it was in the "Pre-Operational" or "Stopped" state on receiving "START REMOTE NODE" indication.

When the CANopen network is started using the NMT "START REMOTE NODE" services, all device functionalities can be used. Communication can be carried out via PDOs or SDOs.

** WARNING****RISK OF UNINTENDED DEVICE OPERATION**

Do not change the device configuration when it is in "Operational" state. Changing the equipment configuration while it is in the "Operational" state may result in the device behaving in an unexpected manner and/or in equipment damage or injury to personnel. If the device needs to be reconfigured, put it in the "Pre-Operational" state and check that this has been done correctly before proceeding to modify the configuration.

**Failure to follow this instruction can result in death, serious injury, or equipment damage.**

## Process Data Object (PDO) Transmission

**Definition of PDO** PDOs are objects which provide the communication interface with process data and enable them to be exchanged in real time. A CANopen device's PDO set describes the implicit exchanges between this device and its communication partners on the network.

The exchange of PDOs is authorized when the device is in "Operational" mode.

**Types of PDO** There are two types of PDO:

- PDOs transmitted by the device ("Transmit PDO", "TPDO")
- PDOs received by the device ("Receive PDO", "RPDO")

**PDO Consumer/Producer** PDOs are based on the "Producer / consumer" model ("Producer" / "Consumer"). The device which sends out a PDO is called the producer, while the device receiving it is known as the consumer.

**PDO Transmission Modes** In addition to data to be transported, it is possible to configure the type of exchange for each PDO.

The PDO transmission mode can be configured as described in the table below.

Transfer code		Transmission mode					Notes	
Dec.	Hex.	Cyclic	Acyclic	Synchronous	Asynchronous	only RTR		
0	0		x	x			Send PDO on first SYNC message following an event	
1 to 240	1 to F0	x		x			Send PDO every x SYNC messages	
241 to 251	F1 to FB	Reserved						-
252	FC			x		x	Receive SYNC message and send PDO on Remote Request	
253	FD				x	x	Update data and send PDO on Remote Request	
254 to 255	FE to FF				x		Send PDO on event (Change of state mode)	



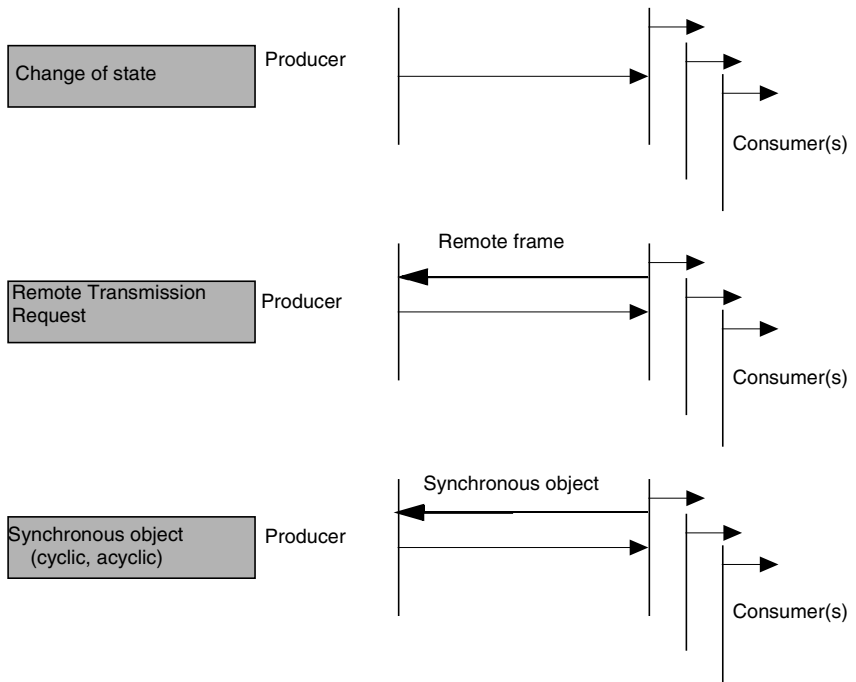

**Synchronous  
(mode 0 to 240)**

For certain applications, synchronization between scanning of the inputs and activation of the outputs may be necessary.

For this reason, CANopen provides the "SYNC" object, a high-priority CAN message without any working data, which, when it is received by the synchronized devices is used to trigger the reading of inputs or activation of outputs (Trigger).

The following diagram shows the time data for synchronized PDO transmission.

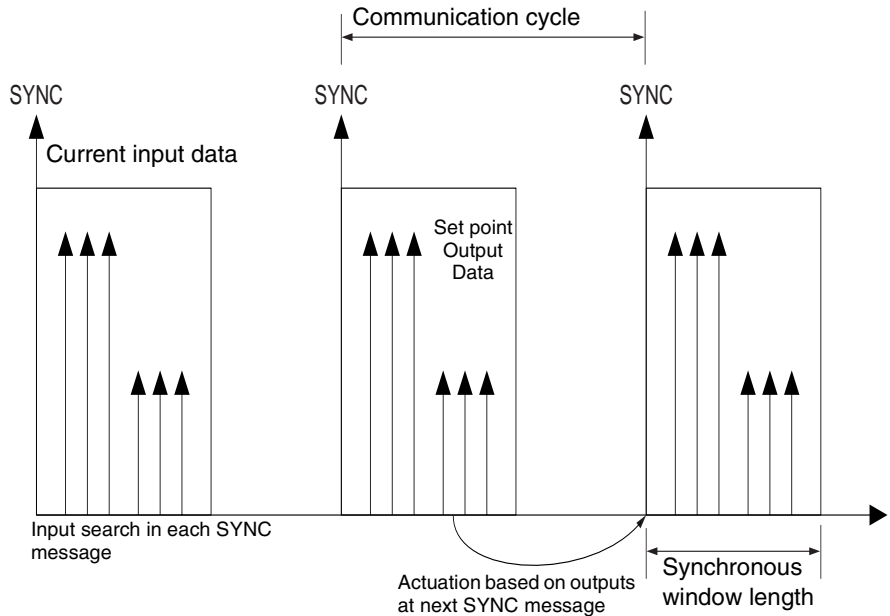
**Synchronous  
RTR (mode 252)**

Aside from polling by request ("timing-related polling"), the slaves can also be polled by the master by using data request messages ("Remote-Frames", known as RTR messages).

In mode 252, the device uses the synchronization message to trigger transmission of the PDO once it has received the RTR message.

**Asynchronous  
RTR (mode 253)**

In mode 253, the TPDOs are transmitted once the RTR message is received.

**"Change of state" (modes 254 and 255)**

The asynchronous exchange of PDO in "Change of state" mode enables the rapid modification of an input value, followed by immediate confirmation of the change of value. This avoids the need to wait for the master to send a request.

A high priority bus status is assigned to the "Change of state" mode and only the updated input value is returned, not the image of the full process, thus considerably reducing traffic on the bus.

"Change of state" corresponds to the modification of the input value (event control).

** WARNING****RISK OF UNINTENDED DEVICE OPERATION**

The "Change of State" mode must not be used for inputs/outputs whose state changes continuously (such as analog inputs). The continual modification of I/Os using the "Change of State" mode may block the transmission of other crucial commands, resulting in the unintended operation of the device.

**Failure to follow this instruction can result in death, serious injury, or equipment damage.**

## Inhibit Time and Event Timer

---

### Inhibit Time

In event transmission mode, the Inhibit Time utility is used to define a minimum time delay before transmission of a new PDO. This avoids overloading the bus where a significant number of events occur in rapid succession.

The Inhibit Time is expressed in multiple of 100  $\mu$ s.

Values (hex.)	Values (dec.)	Actual values (ms)
0000H	0	0000
000AH	10	1
0064H	100	10
03E8H	1000	100
2710H	10 000	1000
FFFFH	65 535	6553.5

### Event Timer

In event transmission mode, the Event Timer is used to define an expiry time delay where transmission of a PDO will be forced, even if there has been no change in status .

The Event Timer is expressed in milliseconds.

Values (hex.)	Values (dec.)	Actual values (ms)
0000H	0	0 (deactivated)
000AH	10	10
0064H	100	100
01F4H	500	500
03E8H	1000	1000
1388H	5000	5000
2710H	10 000	10 000

---

## Access to Data by Explicit Exchanges (SDO)

---

**What is an SDO?** An SDO allows a device's data to be accessed by using explicit requests. The SDO service is available when the device is in "Operational" or "Pre-Operational" state.

---

**Types of SDO** There are two types of SDO:

- Read SDOs (Download SDO)
- Write SDOs (Upload SDO)

---

**The Producer/Consumer Model** The SDO protocol is based on a 'Producer/Consumer' model.

***For a Download SDO***

The client sends a request indicating the object to be read.

The server returns the data contained within the object.

***For an Upload SDO***

The client sends a request indicating the object to be written to and the desired value.

After the object has been updated, the server returns a confirmation message.

***For an unprocessed SDO***

In both cases, if an SDO was not able to be processed, the server returns an error code (abort code).

---

## "Node-Guarding" and "Life-Guarding" Monitoring Protocols

---

### Introduction

Error monitoring protocols are used to detect communication errors on the network. The default monitoring method, "Node-Guarding", consists in the master controlling the slaves. It is possible to add "Life-Guarding" control of the master by the slaves.

**Note:** The simultaneous use of both monitoring methods, "Guarding" and "Heartbeat", is impossible. Should both methods be activated at once, the equipment will only use the "Heartbeat" monitoring method.

---

### Definition of "Life-Time"

The "Life-Time" parameter is calculated as follows:

"Life-Time" = "Guard-Time" x "Life-Time-Factor"

The object 100CH contains the "Guard-Time" parameter expressed in milliseconds. The object 100DH contains the "Life-Time-Factor" parameter.

---

### Activation of Monitoring

When one of the two parameters "Life-Time-Factor" or "Guard-Time" is set to "0" (default configuration), the device does not perform monitoring (no "Life-Guarding").

To activate monitoring over time, you must enter a value (minimum 1) in the object 100DH and specify a time in ms in the object 100CH.

Common typical values for the "Guard-Time" parameter lie between 250 ms and 2 s.

---

### Reliable Operation

To enable reliable and secure operation, the user must enter a "Life-Time-Factor" with a minimum value of 2.

When the value 1 is used, should a delay occur due to the processing of high priority messages or internal processing on the "Node-Guarding" master, the device switches back to the "Pre-Operational" default state without generating any errors.

## **WARNING**

### **RISK OF UNINTENDED DEVICE OPERATION**

Set the "Life-Time-Factor" (object 100DH) to a minimum value of 2 to prevent any inadvertent change of state to "Pre-Operational" state. Depending on the I/O configuration, an inadvertent change of state may result in unintended device operation.

**Failure to follow this instruction can result in death, serious injury, or equipment damage.**

---

**Importance of Monitoring**

These two monitoring mechanisms are especially important in the CANopen system. Devices connected to the bus do not regularly indicate their presence in operating mode, commanded by "Event".

**Slave Monitoring**

Monitoring is performed in the following way:

Phase	Description
1	The master sets "Remote-Frames" (or "Remote-Transmit-Request" request messages) on the "Guarding-CobID" of the slaves to be monitored.
2	The slaves concerned respond by sending the "Guarding" message. This message contains the "Status-Code" of the slave and the "Toggle-Bit", which changes after each message.
3	The NMT (Network Management Telegram) master compares the "Status" and "Toggle-Bit" information: If they are not in the expected state or if no response is received, the NMT master considers that an error has occurred on the slave.

**Master Monitoring**

If the master requests "Guarding" messages on a strictly cyclical basis, the slave can detect a master failure.

If the slave does not receive a request from the master within the defined "Life-Time" interval ("Guarding" error), it considers that a master failure has occurred ("Watchdog" function).

In this case, the corresponding outputs go into fallback mode and the slave switches back into "Pre-Operational" mode.

## **WARNING**

### **RISK OF UNINTENDED DEVICE OPERATION**

An unexpected change in state to "Pre-Operational" mode may occur when the slave does not successfully detect the master's request even though a slave-master communication monitoring protocol is used.

Depending on the configuration of the slave's inputs and outputs, this change in state may result in unintended device operation or in bodily injury or equipment damage. The person in charge of configuring the system is fully responsible for the configuration of the slave inputs/outputs and must ensure secure fallback operations in the event of a loss of master/slave communication. The person in charge of the configuration must also take all necessary steps to ensure equipment and personnel safety should it prove impossible to secure the fallback operations. **Failure to follow this instruction can result in death, serious injury, or equipment damage.**

**Note:** Even if the monitoring function over time is disabled ("Guard-Time" and "Life-Time-Factor" registers set to 0), the slave will respond to a remote request from the master.

**"Guarding" Protocol**

The initial value of the "Toggle-Bit" sent in the first "Guarding" message is "0".

Then, the "Toggle" bit changes in each subsequent "Guarding" message, which makes it possible to indicate if a message has been lost.

The network state of the device is indicated in the seven remaining bits:

Network state	Response in hex.
Stopped	04H or 84H
Pre-operational	7FH or FFH
Operational	05H or 85H



## The "Heartbeat" Error Monitoring Protocol

### Operation of "Heartbeat" Mechanism

The default monitoring method is "Node-Guarding". If a non-zero value is written in the object 1017H, the "Heartbeat" mechanism is used.

If the Heartbeat error monitoring protocol is selected, the producer transmits a "Heartbeat" message periodically, depending on the "Producer Heartbeat Time" parameter.

The devices responsible for monitoring this message ("Heartbeat Consumer") generate a "HeartBeat" event if the message is not received in the configured time ("Consumer Heartbeat Time").

**Note:** The simultaneous use of both monitoring methods, "Guarding" and "Heartbeat", is impossible. Should both methods be activated at once, the equipment will only use the "Heartbeat" monitoring method.

### Meaning of Possible Values

The "Heartbeat" message indicates that the device status is one byte long and is formatted as follows:

- The most significant bit is reserved and always has a value of 0
- The 7 least significant bits provide the status for the device producing the "Heartbeat" message.

The possible values are as follows:

Status of the "Heartbeat Producer"	Value (Decimal)
Boot-Up	0
Stopped	4
Operational	5
Pre-Operational	127

## 4.3 Behavior of FTB CANopen Splitter boxes

---

### Presentation

---

#### Introduction

This section addresses the different behavior patterns of the Advantys FTB CANopen IP67 splitter and the saving of different parameters.

---

#### What's in this Section?

This section contains the following topics:

Topic	Page
Behavior at Power-up	67
Behavior in the Case of Communication Error	68
Saving / Restoring Parameters	69
List of Saved Parameters	70

---

## Behavior at Power-up

---

### Description

The behavior of the Advantys FTB 1CN splitter box at power-up is in compliance with the "CANOPEN BOOT-UP (see *CANopen "Boot-Up", p. 53*)" Diagram.

***If a back-up configuration exists***

Where a save has been carried out, the saved parameters are applied prior to switching to "Pre-Operational" status.

***If a back-up configuration does not exist***

If there is no back-up configuration, the Advantys FTB splitter box initializes the CANopen data with the default parameters.

---

## Behavior in the Case of Communication Error

---

### **Description**

In the event of a communication error detected by one of the error monitoring protocols ("Node-Guarding" or "Heartbeat"), fallback values are applied physically on the outputs until the next write of the output command object and when the communication error has disappeared.

---

---

## Saving / Restoring Parameters

---

### Management of Saved Parameters

During initial power up, the Advantys splitter box is initialized with the default parameters. During subsequent power ups, it is initialized with the saved parameters.

**Note:** When the master detects the presence of the splitter box on the network, the parameters of the splitter box that are re-defined in the master's configuration tool are overwritten.

### Updating Default Parameters

Saved parameters are only applied once the speed on the Advantys splitter box has been detected.

### Saving and Resetting Parameters

The back-up of parameters is performed by writing a signature to the object 1010H (see *Object 1010H: Store Parameters, p. 146*) These parameters will be used during the next start-ups.

Saved parameters are reset with the default values by writing a signature in the object 1011H (see *Object 1011H: Restore Default Parameters, p. 148*).

### Recommendations to Avoid Data Losses

While writing or deleting saved parameters, the slave no longer processes communications received via the CANopen bus. During this operation, none of the messages transmitted to the slave are taken into account (this includes SDO or Node-Guarding messages).

In order to avoid equipment damage or injury to personnel as well as any losses of data, it is not advisable to initiate parameter saves or restitution when the equipment is in "Operational" mode.

## **WARNING**

### **RISK OF UNINTENDED EQUIPMENT OPERATION**

The splitter box must be switched to the "Pre-Operational" state to save its configuration. The saving process takes 1 to 2 seconds. If the save takes place in the "Operational" state, the outputs will not be updated during the saving process.

**Failure to follow this instruction can result in death, serious injury, or equipment damage.**

## List of Saved Parameters

---

### Communication Profile Objects

The objects that are saved or reused on start-up are as follows:

- 1005H : COB-ID SYNC Message
  - 1006H : Communication Cycle Period
  - 100CH : Guard Time
  - 100DH : Life Time Factor
  - 1014H : COB-ID Emergency Message (EMCY)
  - 1016H : Consumer Heartbeat Time
  - 1017H : Producer Heartbeat Time
  - 1400H...1405H : Receive PDO Communication Parameters
  - 1600H...1605H : Receive PDO Mapping Parameters
  - 1800H...1805H : Transmit PDO Communication Parameters
  - 1A00H...1A05H : Transmit PDO Mapping Parameters
- 

### Discrete I/O Configuration Objects

The discrete I/Os configuration objects are as follows:

- 2000H : Input / Diag Parameter
- 2001H : Input / Output Parameter
- 6102H : Polarity Inputs
- 6103H : Filter Constant Input 16 Bits
- 6200H : Write Outputs 8 Bits
- 6300H : Write Outputs 16 Bits
- 6302H : Polarity Outputs 16 Bits
- 6306H : Fallback Mode 16 Bits
- 6307H : Fallback Value 16 Bits
- 6308H : Filter Mask Outputs 16 Bits

## DANGER

### **RISK OF UNINTENDED EQUIPMENT OPERATION**

Check the contents of objects 6200H and 6300H before switching the product in "Operational" state. Output write objects 6200H and 6300H are saved. Following power up, the switch to "Operational" state will apply to the saved output values. **Failure to follow this instruction will result in death or serious injury.**

---

---

# Application-Specific Functions

# 5

---

## Presentation

### Introduction

The FTB splitter box offers discrete input, output and diagnostics channels and configurable input or output channels, depending on its version. This following chapter describes the operating modes for these different channels.

### What's in this Chapter?

This chapter contains the following topics:

Topic	Page
List of Objects	72
Description of the Discrete Inputs	74
Description of Discrete Outputs	75
Description of Configurable Discrete I/Os	76
List of Advantys FTB 1CN08E08SP0 Splitter Box I/O Objects	78
List of Advantys FTB 1CN12E04SP0 Splitter Box I/O Objects	81
List of Advantys FTB 1CN16EP0 and FTB 1CN16EM0 Splitter Box I/O Objects	85
List of Advantys FTB 1CN16CP0 and FTB 1CN16CM0 Splitter Box I/O Objects	87
List of Advantys FTB 1CN08E08CM0 Splitter Box I/O Objects	91

## List of Objects

### List of Communication Objects

The communication objects are listed in the following table:

Object
<i>Object 1000H: Device Type, p. 135</i>
<i>Object 1001H: Error Register, p. 136</i>
<i>Object 1002H: Manufacturer Status Register, p. 137</i>
<i>Object 1003H: Pre-defined Error Field, p. 138</i>
<i>Object 1005H: COB-ID SYNC Message, p. 140</i>
<i>Object 1006H: Communication Cycle Period, p. 141</i>
<i>Object 1008H: Manufacturer Device Name, p. 142</i>
<i>Object 100AH: Manufacturer Software Version (MSV), p. 143</i>
<i>Object 100CH: Guard Time, p. 144</i>
<i>Object 100DH: Life Time Factor, p. 145</i>
<i>Object 1010H: Store Parameters, p. 146</i>
<i>Object 1011H: Restore Default Parameters, p. 148</i>
<i>Object 1014H: COB-ID Emergency Message (EMCY), p. 150</i>
<i>Object 1016H: Consumer Heartbeat Time, p. 151</i>
<i>Object 1017H: Producer Heartbeat Time, p. 152</i>
<i>Object 1018H: Identity Object, p. 153</i>
<i>Object 1200H: Server SDO Parameter, p. 154</i>
<i>Object 1400H: 1st Receive PDO Communication Parameter, p. 155</i>
<i>Object 1405H: 2nd Receive PDO Communication Parameter, p. 156</i>
<i>Object 1600H: 1st Receive PDO Mapping Parameter, p. 157</i>
<i>Object 1605H: 2nd Receive PDO Mapping Parameter, p. 159</i>
<i>Object 1800H: 1st Transmit PDO Communication Parameter, p. 161</i>
<i>Object 1805H: 2nd Transmit PDO Communication Parameter, p. 164</i>
<i>Object 1A00H: 1st Transmit PDO Mapping Parameter, p. 167</i>
<i>Object 1A05H: 2nd Transmit PDO Mapping Parameter, p. 169</i>



**List of  
Manufacturer-  
specific Profile  
Objects**

The manufacturer-specific profile objects are listed in the following table:

Object
<i>Object 2000H: Input / Diag Parameter, p. 172</i>
<i>Object 2001H: Input/Output Parameter, p. 173</i>
<i>Object 3000H: Manufacturer Specific Diagnostic, p. 174</i>

**List of Device  
Profile Objects**

The device profile objects are listed in the following table:

Object
<i>Object 6000H: Read Inputs 8 Bits, p. 176</i>
<i>Object 6100H: Read Input 16 Bits, p. 177</i>
<i>Object 6102H: Polarity Input, p. 178</i>
<i>Object 6103H: Filter Constant Input 16 Bits, p. 179</i>
<i>Object 6200H: Write Outputs 8 Bits, p. 180</i>
<i>Object 6300H: Write Outputs 16 Bits, p. 181</i>
<i>Object 6302H: Polarity Outputs 16 Bits, p. 182</i>
<i>Object 6306H: Fallback Mode 16 Bits, p. 183</i>
<i>Object 6307H: Fallback Value 16 Bits, p. 184</i>
<i>Object 6308H: Filter Mask Output 16 Bits , p. 185</i>

## Description of the Discrete Inputs

**Discrete Inputs** Input reading made per byte. Each input byte is contained in the sub-index of object 6000H.

For each input, the following parameters may be modified:

- Polarity (object 6102H)
- Filtering constant (object 6103H)

The 2000H object is used to configure inputs 10 to 17 as a discrete input or a diagnostics input.

The state displayed on the inputs is determined by the configuration registers as described below:

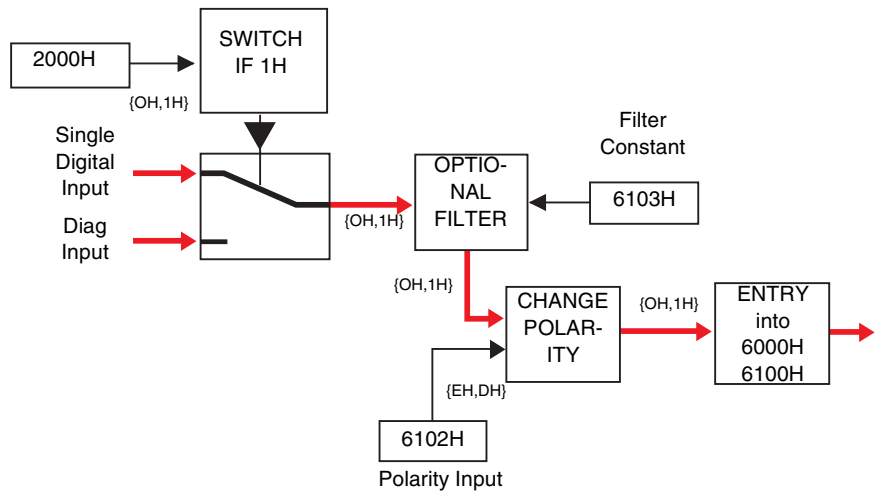

## Description of Discrete Outputs

**Discrete Outputs** The discrete outputs are controlled by a command in the sub-index of object 6200H.

For each output, the following parameters may be modified:

- Polarity (object 6302H)
- Filter mask (object 6308H)

In the event of an error (loss of communication with the master for example), the fallback mode is applied.

The state of the output is determined by the configuration registers as described below:

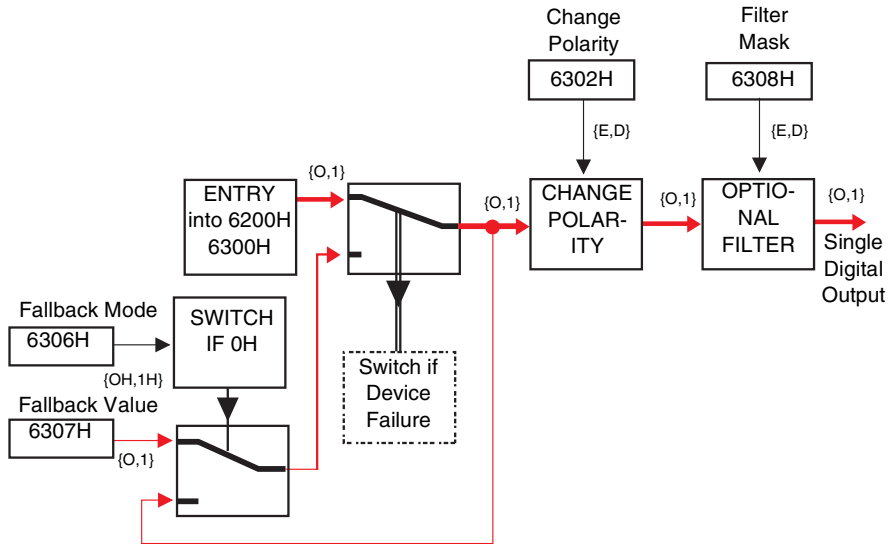

## Description of Configurable Discrete I/Os

### Configurable Splitters

The configurable splitter boxes are as follows:

- FTB 1CN16CP0
- FTB 1CN16CM0
- FTB 1CN08E08CM0

### Channel Configured for Discrete Output

Write outputs are per word. Each output word is contained in the sub-index of object 6200H.

For each output, the following parameters may be modified:

- Polarity (object 6302H)
- Filter mask (object 6308H)

In the event of an error (loss of communication with the master for example), the fallback mode is applied.

The state applied to the output is determined by the configuration registers as described below:

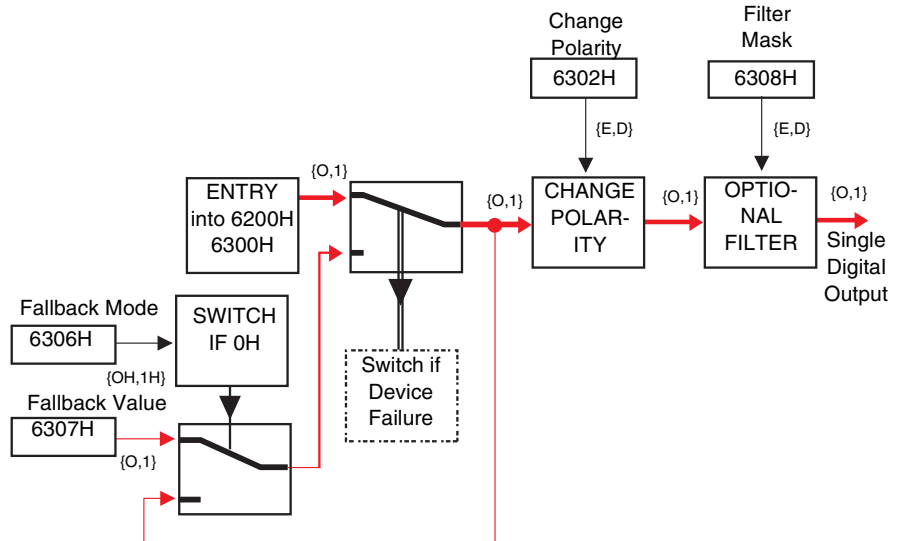

## Channel Configured for Discrete Input

Input reading made per byte. Each input byte is contained in the sub-index of object 6000H.

For each input, the following parameters may be modified:

- Polarity (object 6102H)
- Filtering constant (object 6103H)

The 2000H object is used to configure inputs 10 to 17 as a discrete input or a diagnostics input.

The state displayed on the inputs is defined by the configuration registers as described below:

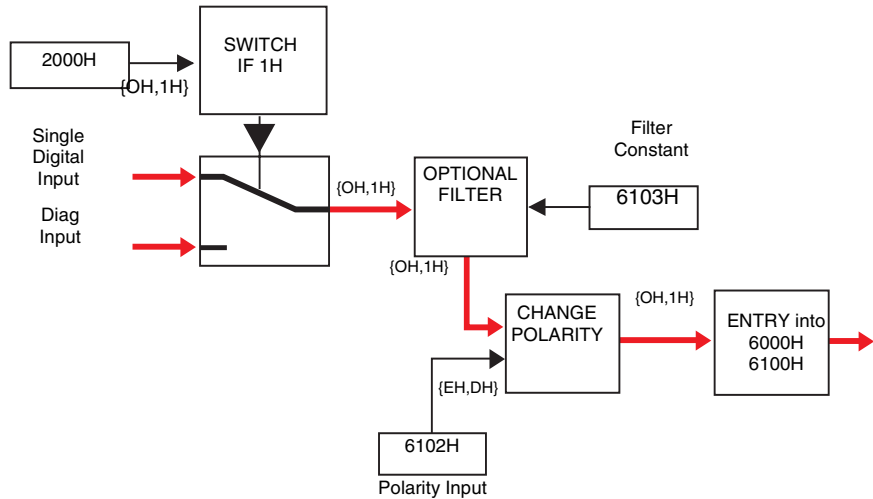

## List of Advantys FTB 1CN08E08SP0 Splitter Box I/O Objects

### List of FTB 1CN08E08SPO Input Objects

The list of input objects for the Advantys FTB 1CN08E08SP0 splitter box is given in the following table:

Object	Sub-index	Bit	Description
2000H	1	Bit 0	Choice between the "input" function and the "diagnostics input" function for channel 10
		...	...
		Bit 7	Choice between the "input" function and the "diagnostics input" function for channel 17
6000H	1	Bit 0	Not assigned
		...	...
		Bit 7	Not assigned
	2	Bit 0	Reading of channel 10 input
		...	...
		Bit 7	Reading of channel 17 input
6100H	1	Bit 0	Not assigned
		...	...
		Bit 7	Not assigned
		Bit 8	Reading of channel 10 input
		...	...
		Bit 15	Reading of channel 17 input
6102H	1	Bit 0	Not assigned
		...	...
		Bit 7	Not assigned
		Bit 8	Polarity of channel 10
		...	...
		Bit 15	Polarity of channel 17
6103H	1	Bit 0	Not assigned
		...	...
		Bit 7	Not assigned
		Bit 8	Channel 10 masking
		...	...
		Bit 15	Channel 17 masking

**Note:** All the objects are 16-bit word tables except for 2000H and 6000H.

- Sub-index 1 of object 6000H corresponds to the 6100H (pin 4) object's least significant byte
- Sub-index 2 of object 6000H corresponds to the 6300H (pin 2) object's most significant byte.
- Object 2000H, read by byte, concerns channels 10 to 17 only (pin 2).

### List of FTB 1CN08E08SP0 Output Objects

The list of output objects for the Advantys FTB 1CN08E08SP0 splitter box is given in the following table:

Object	Sub-index	Bit	Description
6200H	1	Bit 0	Writing of channel 0 output
		...	...
		Bit 7	Writing of channel 7 output
6300H	1	Bit 0	Writing of channel 0 output
		...	...
		Bit 7	Writing of channel 7 output
		Bit 8	Not assigned
		...	...
6302H	1	Bit 15	Not assigned
		...	...
		Bit 0	Polarity of channel 0 output
		...	...
		Bit 7	Polarity of channel 7 output
6306H	1	Bit 8	Not assigned
		...	...
		Bit 0	Fallback mode of channel 0 output
		...	...
		Bit 7	Fallback mode of channel 7 output
		Bit 8	Not assigned
		...	...
		Bit 15	Not assigned
		...	...
		Bit 7	Fallback mode of channel 7 output

Object	Sub-index	Bit	Description
6307H	1	Bit 0	Fallback value of channel 0 output
		...	...
		Bit 7	Fallback value of channel 7 output
		Bit 8	Not assigned
		...	...
		Bit 15	Not assigned
6308H	1	Bit 0	Masking of channel 0 output
		...	...
		Bit 7	Masking of channel 7 output
		Bit 8	Not assigned
		...	...
		Bit 15	Not assigned

**Note:** All the objects are 16-bit word tables except for 6200H. Sub-index 1 of object 6200H corresponds to the 6300H object's least significant byte.

---



## List of Advantys FTB 1CN12E04SP0 Splitter Box I/O Objects

### List of FTB 1CN12E04SP0 Input Objects

The list of input objects for the Advantys FTB 1CN12E04SP0 splitter box is given in the following table:

Object	Sub-index	Bit	Description
2000H	1	Bit 0	Choice between the "input" function and the "diagnostics input" function for channel 10
		...	...
		Bit 7	Choice between the "input" function and the "diagnostics input" function for channel 17
6000H	1	Bit 0	Reading of channel 0 input
		...	...
		Bit 3	Reading of channel 3 input
		Bit 4	Not assigned
		...	...
	Bit 7	Not assigned	
	2	Bit 8	Reading of channel 10 input
...		...	
Bit 15		Reading of channel 17 input	
6100H	1	Bit 0	Reading of channel 0 input
		...	...
		Bit 3	Reading of channel 3 input
		Bit 4	Not assigned
		...	...
		Bit 7	Not assigned
		Bit 8	Reading of channel 10 input
		...	...
Bit 15	Reading of channel 17 input		

Object	Sub-index	Bit	Description
6102H	1	Bit 0	Polarity of channel 0
		...	...
		Bit 3	Polarity of channel 3
		Bit 4	Not assigned
		...	...
		Bit 7	Not assigned
		Bit 8	Polarity of channel 10
		...	...
		Bit 15	Polarity of channel 17
6103H	1	Bit 0	Channel 0 masking
		...	...
		Bit 3	Channel 3 masking
		Bit 4	Not assigned
		...	...
		Bit 7	Not assigned
		Bit 8	Channel 10 masking
		...	...
		Bit 15	Channel 17 masking

**Note:** All the objects are 16-bit word tables except for 2000H and 6000H.

- Sub-index 1 of object 6000H corresponds to the 6100H (pin 4) object's least significant byte
- Sub-index 2 of object 6000H corresponds to the 6300H (pin 2) object's most significant byte.
- Object 2000H, read by byte, concerns channels 10 to 17 only (pin 2).

**List of FTB  
1CN12E04SP0  
Output Objects**

The list of output objects for the Advantys FTB 1CN12E04SP0 splitter box is given in the following table:

Object	Sub-index	Bit	Description
6200H	1	Bit 0	Not assigned
		...	...
		Bit 3	Not assigned
		Bit 4	Writing of channel 4 output
		...	...
	2	Bit 7	Writing of channel 7 output
		...	...
		Bit 0	Not assigned
		...	...
		Bit 7	Not assigned
6300H	1	Bit 0	Not assigned
		...	...
		Bit 3	Not assigned
		Bit 4	Writing of channel 4 output
		...	...
		Bit 7	Writing of channel 7 output
		Bit 8	Not assigned
		Bit 15	Not assigned
6302H	1	Bit 0	Not assigned
		...	...
		Bit 3	Not assigned
		Bit 4	Polarity of channel 4 output
		...	...
		Bit 7	Polarity of channel 7 output
		Bit 8	Not assigned
		Bit 15	Not assigned

Object	Sub-index	Bit	Description
6306H	1	Bit 0	Not assigned
		...	...
		Bit 3	Not assigned
		Bit 4	Fallback mode of channel 4 output
		...	...
		Bit 7	Fallback mode of channel 7 output
		Bit 8	Not assigned
		Bit 15	Not assigned
6307H	1	Bit 0	Not assigned
		...	...
		Bit 3	Not assigned
		Bit 4	Fallback value of channel 4 output
		...	...
		Bit 7	Fallback value of channel 7 output
		Bit 8	Not assigned
		Bit 15	Not assigned
6308H	1	Bit 0	Not assigned
		...	...
		Bit 3	Not assigned
		Bit 4	Masking of channel 4 output
		...	...
		Bit 7	Masking of channel 7 output
		Bit 8	Not assigned
		Bit 15	Not assigned

**Note:** All the objects are 16-bit word tables except for 6200H. Sub-index 1 of object 6200H corresponds to the 6300H object's least significant byte.

## List of Advantys FTB 1CN16EP0 and FTB 1CN16EM0 Splitter Box I/O Objects

### List of FTB 1CN16EP0 and FTB 1CN16EM0 Input Objects

The list of input objects for the Advantys FTB 1CN16EP0 and FTB 1CN16EM0 splitter boxes is given in the following table:

Object	Sub-index	Bit	Description
2000H	1	Bit 0	Choice between the "input" function and the "diagnostics input" function for channel 10
		...	...
		Bit 7	Choice between the "input" function and the "diagnostics input" function for channel 17
6000H	1	Bit 0	Reading of channel 0 input
		...	...
		Bit 7	Reading of channel 7 input
	2	Bit 0	Reading of channel 10 input
		...	...
		Bit 7	Reading of channel 17 input
6100H	1	Bit 0	Reading of channel 0 input
		...	...
		Bit 15	Reading of channel 17 input
6102H	1	Bit 0	Polarity of channel 0
		...	...
		Bit 15	Polarity of channel 17
6103H	1	Bit 0	Channel 0 masking
		...	...
		Bit 15	Channel 17 masking

**Note:** All the objects are 16-bit word tables except for 2000H and 6000H.

- Sub-index 1 of object 6000H corresponds to the 6100H (pin 4) object's least significant byte
- Sub-index 2 of object 6000H corresponds to the 6300H (pin 2) object's most significant byte.
- Object 2000H, read by byte, concerns channels 10 to 17 only (pin 2).

**List of  
FTB 1CN16EP0  
and  
FTB 1CN16EM0  
Output Objects**

The Advantys FTB 1CN16EP0 and FTB 1CN16EM0 splitter boxes have no outputs.

---

## List of Advantys FTB 1CN16CP0 and FTB 1CN16CM0 Splitter Box I/O Objects

### Configuration Object 2001H

Object 2001H is used to select the "input" and "output" functions for the 00 to 17 channels as an input or output. *Object 2001H: Input/Output Parameter, p. 173.*

The table below presents the mapping of object 2001H:

Object	Sub-index	Bit	Description
2001H	1	Bit 0	Choice between the "input" function and the "output" function for channel 0
		...	...
		Bit 7	Choice between the "input" function and the "output" function for channel 7
	2	Bit 8	Choice between the "input" function and the "output" function for channel 10
		...	...
		Bit 15	Choice between the "input" function and the "output" function for channel 17

**Note:** All objects are read by bytes.

**List of  
FTB 1CN16CP0  
and  
FTB 1CN16CM0  
Input Objects**

The list of input objects for the Advantys FTB 1CN16CP0 and FTB 1CN16CM0 splitter boxes is given in the following table:

Object	Sub-index	Bit	Description
2000H	1	Bit 0	Choice between the "input" function and the "diagnostics input" function for channel 10
		...	...
		Bit 7	Choice between the "input" function and the "diagnostics input" function for channel 17
6000H	1	Bit 0	<ul style="list-style-type: none"> <li>● Channel 0 input reading if channel 0 configured for input</li> <li>● Not assigned if channel 0 configured for output</li> </ul>
		...	...
		Bit 7	<ul style="list-style-type: none"> <li>● Channel 7 input reading if channel 7 configured for input</li> <li>● Not assigned if channel 7 configured for output</li> </ul>
	2	Bit 0	<ul style="list-style-type: none"> <li>● Channel 10 input reading if channel 10 configured for input</li> <li>● Channel 10 diagnostics input reading if channel 10 configured for diagnostics input</li> <li>● Not assigned if channel 10 configured for output</li> </ul>
		...	...
		Bit 7	<ul style="list-style-type: none"> <li>● Channel 17 input reading if channel 17 configured for input</li> <li>● Channel 17 diagnostics input reading if channel 17 configured for diagnostics input</li> <li>● Not assigned if channel 17 configured for output</li> </ul>
6100H	1	Bit 0	<ul style="list-style-type: none"> <li>● Channel 0 input reading if channel 0 configured for input</li> <li>● Not assigned if channel 0 configured for output</li> </ul>
		...	...
		Bit 7	<ul style="list-style-type: none"> <li>● Channel 7 input reading if channel 7 configured for input</li> <li>● Not assigned if channel 7 configured for output</li> </ul>
		Bit 8	<ul style="list-style-type: none"> <li>● Channel 10 input reading if channel 10 configured for input</li> <li>● Channel 10 diagnostics input reading if channel 10 configured for diagnostics input</li> <li>● Not assigned if channel 10 configured for output</li> </ul>
		...	...
		Bit 15	<ul style="list-style-type: none"> <li>● Channel 17 input reading if channel 17 configured for input</li> <li>● Channel 17 diagnostics input reading if channel 17 configured for diagnostics input</li> <li>● Not assigned if channel 17 configured for output</li> </ul>



Object	Sub-index	Bit	Description
6102H	1	Bit 0	<ul style="list-style-type: none"> <li>Channel 0 polarity if channel 0 configured for input</li> <li>Not assigned if channel 0 configured for output</li> </ul>
		...	...
		Bit 15	<ul style="list-style-type: none"> <li>Channel 17 polarity if channel 17 configured for input</li> <li>Not assigned if channel 17 configured for output</li> </ul>
6103H	1	Bit 0	<ul style="list-style-type: none"> <li>Channel 0 masking if channel 0 configured for input</li> <li>Not assigned if channel 0 configured for output</li> </ul>
		...	...
		Bit 15	<ul style="list-style-type: none"> <li>Channel 17 masking if channel 17 configured for input</li> <li>Not assigned if channel 17 configured for output</li> </ul>

**Note:** All the objects are 16-bit word tables except for 2000H and 6000H.

- Sub-index 1 of object 6000H corresponds to the 6100H (pin 4) object's least significant byte
- Object 2000H, read by byte, concerns channels 10 to 17 only (pin 2).

### List of FTB 1CN16CP0 and FTB 1CN16CM0 Output Objects

The list of output objects for the Advantys FTB 1CN16CP0 and FTB 1CN16CM0 splitter boxes is given in the following table:

Object	Sub-index	Bit	Description
6200H	1	Bit 0	<ul style="list-style-type: none"> <li>Channel 0 output writing if channel 0 configured for output</li> <li>Not assigned if channel 0 configured for input</li> </ul>
		...	...
		Bit 7	<ul style="list-style-type: none"> <li>Channel 7 output writing if channel 7 configured for output</li> <li>Not assigned if channel 7 configured for input</li> </ul>
	2	Bit 0	<ul style="list-style-type: none"> <li>Channel 10 output writing if channel 10 configured for output</li> <li>Not assigned if channel 10 configured for input</li> </ul>
		Bit 7	<ul style="list-style-type: none"> <li>Channel 17 output writing if channel 17 configured for output</li> <li>Not assigned if channel 17 configured for input</li> </ul>
6300H	1	Bit 0	<ul style="list-style-type: none"> <li>Channel 0 output writing if channel 0 configured for output</li> <li>Not assigned if channel 0 configured for input</li> </ul>
		...	...
		Bit 15	<ul style="list-style-type: none"> <li>Channel 17 output writing if channel 17 configured for output</li> <li>Not assigned if channel 17 configured for input</li> </ul>

Object	Sub-index	Bit	Description
6302H	1	Bit 0	<ul style="list-style-type: none"> <li>Channel 0 output polarity if channel 0 configured for output</li> <li>Not assigned if channel 0 configured for input</li> </ul>
		...	...
		Bit 15	<ul style="list-style-type: none"> <li>Channel 17 output polarity if channel 17 configured for output</li> <li>Not assigned if channel 17 configured for input</li> </ul>
6306H	1	Bit 0	<ul style="list-style-type: none"> <li>Channel 0 output fallback mode if channel 0 configured for output</li> <li>Not assigned if channel 0 configured for input</li> </ul>
		...	...
		Bit 15	<ul style="list-style-type: none"> <li>Channel 17 output fallback mode if channel 17 configured for output</li> <li>Not assigned if channel 17 configured for input</li> </ul>
6307H	1	Bit 0	<ul style="list-style-type: none"> <li>Channel 0 output fallback value if channel 0 configured for output</li> <li>Not assigned if channel 0 configured for input</li> </ul>
		...	...
		Bit 15	<ul style="list-style-type: none"> <li>Channel 17 output fallback value if channel 17 configured for output</li> <li>Not assigned if channel 17 configured for input</li> </ul>
6308H	1	Bit 0	<ul style="list-style-type: none"> <li>Channel 0 output masking if channel 0 configured for output</li> <li>Not assigned if channel 0 configured for input</li> </ul>
		...	...
		Bit 15	<ul style="list-style-type: none"> <li>Channel 17 output masking if channel 17 configured for output</li> <li>Not assigned if channel 17 configured for input</li> </ul>

**Note:** All the objects are 16-bit word tables except for 6200H.

For object 6200H:

- Sub-index 1 corresponds to the 6300H (pin 4) object's least significant byte
- Sub-index 2 corresponds to the 6300H (pin 2) object's most significant byte

## List of Advantys FTB 1CN08E08CM0 Splitter Box I/O Objects

### Configuration Object 2001H

Object 2001H is used to select the "input" and "output" functions for channels 00 to 17 as an input or output. *Object 2001H: Input/Output Parameter, p. 173.*

The table below presents the mapping of object 2001H:

Object	Sub-index	Bit	Description
2001H	1	Bit 0	Choice between the "input" function and the "output" function for channel 0
		...	...
		Bit 7	Choice between the "input" function and the "output" function for channel 7
	2	Bit 8	Not assigned
		...	...
		Bit 15	Not assigned

**Note:** All objects are read by bytes.

### List of FTB 1CN08E08CM0 Input Objects

The list of input objects for the Advantys FTB 1CN08E08CM0 splitter box is given in the following table:

Object	Sub-index	Bit	Description
2000H	1	Bit 0	Choice between the "input" function and the "diagnostics input" function for channel 10
		...	...
		Bit 7	Choice between the "input" function and the "diagnostics input" function for channel 17
6000H	1	Bit 0	<ul style="list-style-type: none"> <li>● Channel 0 input reading if channel 0 configured for input</li> <li>● Not assigned if channel 0 configured for output</li> </ul>
		...	...
		Bit 7	<ul style="list-style-type: none"> <li>● Channel 7 input reading if channel 7 configured for input</li> <li>● Not assigned if channel 7 configured for output</li> </ul>
	2	Bit 0	<ul style="list-style-type: none"> <li>● Channel 10 input reading if channel 10 configured for input</li> <li>● Channel 10 diagnostics input reading if channel 10 configured for diagnostics input</li> </ul>
		...	...
		Bit 7	<ul style="list-style-type: none"> <li>● Channel 17 input reading if channel 17 configured for input</li> <li>● Channel 17 diagnostics input reading if channel 17 configured for diagnostics input</li> </ul>
6100H	1	Bit 0	<ul style="list-style-type: none"> <li>● Channel 0 input reading if channel 0 configured for input</li> <li>● Not assigned if channel 0 configured for output</li> </ul>
		...	...
		Bit 7	<ul style="list-style-type: none"> <li>● Channel 7 input reading if channel 7 configured for input</li> <li>● Not assigned if channel 7 configured for output</li> </ul>
		Bit 8	<ul style="list-style-type: none"> <li>● Channel 10 input reading if channel 10 configured for input</li> <li>● Channel 10 diagnostics input reading if channel 10 configured for diagnostics input</li> </ul>
		...	...
		Bit 15	<ul style="list-style-type: none"> <li>● Channel 17 input reading if channel 17 configured for input</li> <li>● Channel 17 diagnostics input reading if channel 17 configured for diagnostics input</li> </ul>

Object	Sub-index	Bit	Description
6102H	1	Bit 0	<ul style="list-style-type: none"> <li>Channel 0 input polarity if channel 0 configured for input</li> <li>Not assigned if channel 0 configured for output</li> </ul>
		...	...
		Bit 7	<ul style="list-style-type: none"> <li>Channel 7 input polarity if channel 7 configured for input</li> <li>Not assigned if channel 7 configured for output</li> </ul>
		Bit 8	<ul style="list-style-type: none"> <li>Channel 10 input polarity if channel 10 configured for input</li> <li>Channel 10 diagnostics input polarity if channel 10 configured for diagnostics input</li> </ul>
		...	...
		Bit 15	<ul style="list-style-type: none"> <li>Channel 17 input polarity if channel 17 configured for input</li> <li>Channel 17 diagnostics input reading if channel 17 configured for diagnostics input</li> </ul>
6103H	1	Bit 0	<ul style="list-style-type: none"> <li>Channel 0 input masking if channel 0 configured for input</li> <li>Not assigned if channel 0 configured for output</li> </ul>
		...	...
		Bit 7	<ul style="list-style-type: none"> <li>Channel 7 input masking if channel 7 configured for input</li> <li>Not assigned if channel 7 configured for output</li> </ul>
		Bit 8	<ul style="list-style-type: none"> <li>Channel 10 input masking if channel 10 configured for input</li> <li>Channel 10 diagnostics input masking if channel 10 configured for diagnostics input</li> </ul>
		...	...
		Bit 15	<ul style="list-style-type: none"> <li>Channel 17 input masking if channel 17 configured for input</li> <li>Channel 17 diagnostics input masking if channel 17 configured for diagnostics input</li> </ul>

**Note:** All the objects are 16-bit word tables except for 2000H and 6000H.

- Sub-index 1 of object 6000H corresponds to the 6100H (pin 4) object's least significant byte
- Object 2000H, read by byte, concerns channels 10 to 17 only (pin 2).

### List of FTB 1CN08E08CM0 Output Objects

The list of output objects for the Advantys FTB 1CN08E08CM0 splitter box is given in the following table:

Object	Sub-index	Bit	Description
6200H	1	Bit 0	<ul style="list-style-type: none"> <li>Channel 0 output writing if channel 0 configured for output</li> <li>Not assigned if channel 0 configured for input</li> </ul>
		...	...
		Bit 7	<ul style="list-style-type: none"> <li>Channel 7 output writing if channel 7 configured for output</li> <li>Not assigned if channel 7 configured for input</li> </ul>
	2	Bit 8	Not assigned
		...	...
		Bit 15	Not assigned
6300H	1	Bit 0	<ul style="list-style-type: none"> <li>Channel 0 output writing if channel 0 configured for output</li> <li>Not assigned if channel 0 configured for input</li> </ul>
		...	...
		Bit 7	<ul style="list-style-type: none"> <li>Channel 7 output writing if channel 7 configured for output</li> <li>Not assigned if channel 7 configured for input</li> </ul>
		Bit 8	Not assigned
		...	...
		Bit 15	Not assigned
6302H	1	Bit 0	<ul style="list-style-type: none"> <li>Channel 0 output polarity if channel 0 configured for output</li> <li>Not assigned if channel 0 configured for input</li> </ul>
		...	...
		Bit 7	<ul style="list-style-type: none"> <li>Channel 7 output polarity if channel 7 configured for output</li> <li>Not assigned if channel 7 configured for input</li> </ul>
		Bit 8	Not assigned
		...	...
		Bit 15	Not assigned
6306H	1	Bit 0	<ul style="list-style-type: none"> <li>Channel 0 output fallback mode if channel 0 configured for output</li> <li>Not assigned if channel 0 configured for input</li> </ul>
		...	...
		Bit 7	<ul style="list-style-type: none"> <li>Channel 7 output fallback mode if channel 7 configured for output</li> <li>Not assigned if channel 7 configured for input</li> </ul>
		Bit 8	Not assigned
		...	...
		Bit 15	Not assigned

Object	Sub-index	Bit	Description
6307H	1	Bit 0	<ul style="list-style-type: none"> <li>Channel 0 output fallback value if channel 0 configured for output</li> <li>Not assigned if channel 0 configured for input</li> </ul>
		...	...
		Bit 7	<ul style="list-style-type: none"> <li>Channel 7 output fallback value if channel 7 configured for output</li> <li>Not assigned if channel 7 configured for input</li> </ul>
		Bit 8	Not assigned
		...	...
		Bit 15	Not assigned
6308H	1	Bit 0	<ul style="list-style-type: none"> <li>Channel 0 output masking if channel 0 configured for output</li> <li>Not assigned if channel 0 configured for input</li> </ul>
		...	...
		Bit 7	<ul style="list-style-type: none"> <li>Channel 7 output masking if channel 7 configured for output</li> <li>Not assigned if channel 7 configured for input</li> </ul>
		Bit 8	Not assigned
		...	...
		Bit 15	Not assigned

**Note:** All the objects are 16-bit word tables except for 6200H.

For object 6200H:

- Sub-index 1 corresponds to the 6300H (pin 4) object's least significant byte
- Sub-index 2 corresponds to the 6300H (pin 2) object's most significant byte





---

# Software Tools



# 6

---

## Presentation

### Introduction

This chapter deals with Advantys FTB CANopen splitter software installation.

### What's in this Chapter?

This chapter contains the following sections:

Section	Topic	Page
6.1	Introduction to Software Tools	99
6.2	Product Configuration	101
6.3	Network Configuration	107
6.4	PLC Programming	114

---



## 6.1 Introduction to Software Tools

### Introduction

#### General

The products in the Advantys range must be configured to be able to operate correctly on the network. There are three stages in the configuration process:

- Configuration of the Advantys devices and the desired parameters.
- Configuration of the network (master and slaves).
- PLC setup and programming: I/O, startup of the network and subsequent use.

**Note:** For more information, please consult the appropriate documentation for the other network devices that may be required, the Advantys Configuration Tool online help (FTX ES 0\*), the PLC manual etc.

#### Software Tools

The software to be used depends on the PLC software workshop. Certain PLC software workshops can configure the network. The following diagram shows the software to be used for three Telemecanique PLC software workshops:

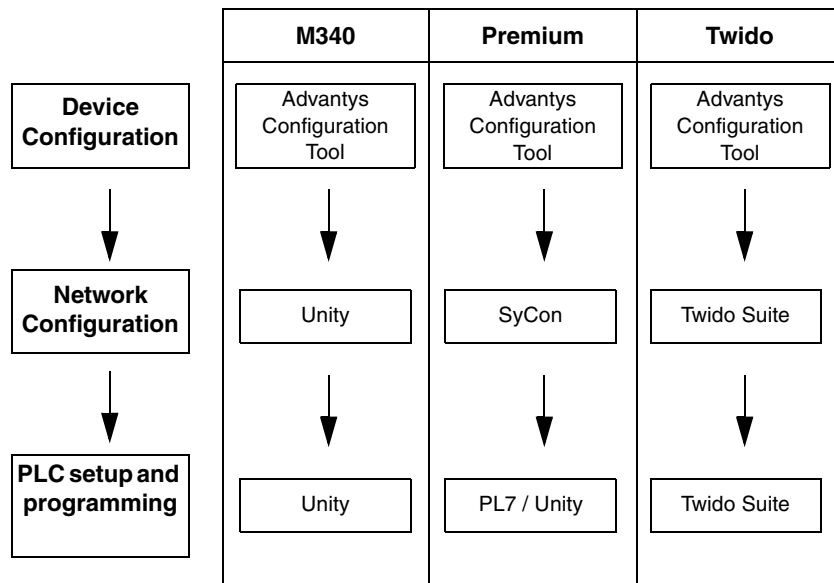

**Note:** With Twido Suite, Advantys Configuration Tool is run directly by Twido Suite to create or modify an island.

**Advantys Device Configuration**

The first phase is accomplished by using the Advantys Configuration Tool (FTX ES 0\*). This tool is used to define each Advantys device, to set the parameters and the functions of the inputs/outputs and to generate the configuration files required to integrate each device into the master.

---

**Configuration Files**

There are two types of configuration file:

- EDS (Electronic Data Sheet) files, which define the structure of the data available in a splitter box (see the object dictionary).
- DCF (Device Configuration File) files which, in addition to the information contained in an EDS file, also contain settings data (Cf. CiA CAN standard DS 306).

**Note:** For further information on EDS file creation, please refer to the user manual or to the Advantys Configuration Tool online help.

---

**Network Configuration**

This phase may be carried out by a specific software application (e.g. SyCon) or by certain PLC software workshops (e.g. Unity, Twido Suite...). This phase involves integrating all devices into the network, and defining the network (master configuration) so as to create a functional network.

---

**PLC Setup and Programming**

This phase is carried out by the operator, via the PLC software workshop.

---

**Software Installation**

Before installing the software, please refer to the relevant manuals.

---

---

## 6.2 Product Configuration

---

### At A Glance

---

#### Introduction

This section describes the tools and operating modes that generate the EDSs and DCFs of the Advantys range of devices using the Advantys Configuration Tool (FTX ES 0•).

The software generates one file per island. An island represents a node on the network with a separate network address. An island can correspond to:

- An OTB module (with or without expansion modules),
  - An FTB splitter box,
  - A modular FTM splitter (module with or without splitters).
- 

#### What's in this Section?

This section contains the following topics:

Topic	Page
Characteristics of an EDS File	102
Existing EDS File for CANopen Advantys FTB Splitter Box	103
Creating a New EDS and DCF Configuration File	104

---

## Characteristics of an EDS File

---

### Description

The EDS file describes all configurable objects for CANopen products. These configurable objects are used to identify the product and specify the appropriate behavior. The parameters of an EDS file contain all the important information relating to the product. For example:

- The product type
- The manufacturer
- The identification of the vendor
- The item number
- The software version
- The hardware version
- The details of all the configurable objects
- etc.

Each EDS file is specific to a product type and cannot be re-used on other products as this will result in the incorrect I/O configuration. It is up to the user to make sure that the correct EDS file is used.

An EDS file can be recognized by its ".eds" extension. Each EDS file is associated with one or more ".dib" image files.

---

## Existing EDS File for CANopen Advantys FTB Splitter Box

### EDS File

The configuration software tool suite allows you to make full use of your Advantys FTB splitter box and can be used to create a new EDS file (see *Creating a New EDS and DCF Configuration File*, p. 104).

If you do not use the Advantys Configuration Tool (ACT), you may use the EDS files supplied on the FTX ES 0• CD whose names are specified in the following table:

For each splitter box, an assigned EDS file to be used is supplied:

Type of splitter box	EDS file name	Image name
FTB 1CN08E08SP0	TEFTB01P01E.eds	<ul style="list-style-type: none"> <li>● TEFTB01P01E_r.dib (run)</li> <li>● TEFTB01P01E_s.dib (stop)</li> <li>● TEFTB01P01E_d.dib (diag)</li> </ul>
FTB 1CN12E04SP0	TEFTB02P01E.eds	<ul style="list-style-type: none"> <li>● TEFTB02P01E_r.dib (run)</li> <li>● TEFTB02P01E_s.dib (stop)</li> <li>● TEFTB02P01E_d.dib (diag)</li> </ul>
FTB 1CN16EP0	TEFTB03P01E.eds	<ul style="list-style-type: none"> <li>● TEFTB03P01E_r.dib (run)</li> <li>● TEFTB03P01E_s.dib (stop)</li> <li>● TEFTB03P01E_d.dib (diag)</li> </ul>
FTB 1CN16EM0	TEFTB03P01E.eds	<ul style="list-style-type: none"> <li>● TEFTB03M01E_r.dib (run)</li> <li>● TEFTB03M01E_s.dib (stop)</li> <li>● TEFTB03M01E_d.dib (diag)</li> </ul>
FTB 1CN16CP0	TEFTB04P01E.eds	<ul style="list-style-type: none"> <li>● TEFTB04P01E_r.dib (run)</li> <li>● TEFTB04P01E_s.dib (stop)</li> <li>● TEFTB04P01E_d.dib (diag)</li> </ul>
FTB 1CN16CM0	TEFTB04MP01E.eds	<ul style="list-style-type: none"> <li>● TEFTB04M01E_r.dib (run)</li> <li>● TEFTB04M01E_s.dib (stop)</li> <li>● TEFTB04M01E_d.dib (diag)</li> </ul>
FTB 1CN08E08CM0	TEFTB05M01E.eds	<ul style="list-style-type: none"> <li>● TEFTB05M01E_r.dib (run)</li> <li>● TEFTB05M01E_s.dib (stop)</li> <li>● TEFTB05M01E_d.dib (diag)</li> </ul>

### WARNING

#### RISK OF UNINTENDED EQUIPMENT OPERATION

Do not modify the EDS file manually, and do not use any configuration tools that have not been approved by Schneider Electric. All modifications must be made using the Advantys Configuration Tool, or be carried out by qualified Schneider Electric personnel.

**Failure to follow this instruction can result in death, serious injury, or equipment damage.**

## Creating a New EDS and DCF Configuration File

### Introduction

Once the Advantys Configuration Tool (ACT) software has been installed and registered, you can begin the process for creating island EDS and DCF configuration files.

### Creating a New EDS and DCF Configuration File

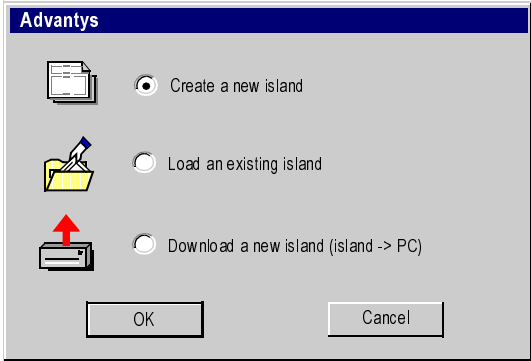
Step	Action
1	<p>Launch the Advantys Configuration Tool software. A window appears:</p>  <ul style="list-style-type: none"><li>● Select <b>Create new island</b></li><li>● Click on the <b>OK</b> button.</li></ul>

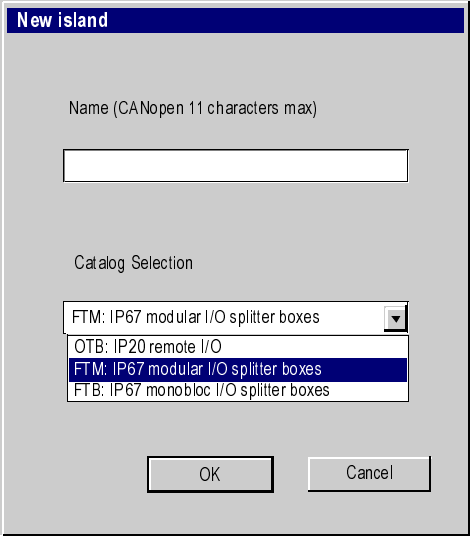

Step	Action
2	<p>The <b>New island</b> window appears:</p>  <p>The creation of an island must be in line with the physical configuration of your installation:</p> <ul style="list-style-type: none"> <li>● Enter the name of the island in the field <b>Name</b>. The name of the island must correspond to the name of the EDS configuration file.</li> <li>● Select the catalog in the <b>Catalog selection</b> drop-down menu.</li> <li>● Confirm your selection by clicking on the <b>OK</b> button</li> </ul>
3	<p><b>Building the Island</b></p> <p>A browser window appears. A representative model of the island can be built in this window. At this point, this is an image of an empty 35mm (1.37in) DIN rail. The catalog browser contains all the references of the catalog selected. Building the island is a "drag and drop" operation:</p> <ul style="list-style-type: none"> <li>● Click on the reference in the catalog browser window and, while holding down the left mouse button, drag the reference over to the DIN rail and drop it (release the mouse button).</li> </ul>

Step	Action
4	<p data-bbox="498 199 710 224"><b>Island Configuration</b></p> <p data-bbox="498 228 1237 280">Once the island has been built, you can set its parameters. The parameters you need to define will depend on the I/O functions you wish to use.</p> <p data-bbox="498 285 1023 310">The islands are configured in the configuration window:</p> <ul data-bbox="498 315 1188 427" style="list-style-type: none"><li data-bbox="498 315 1188 367">● Open the configuration window by double clicking on the island (or by selecting the island and then the <b>Island/Module Editor</b> menu.</li><li data-bbox="498 371 847 396">● Modify the required parameter(s).</li><li data-bbox="498 401 1156 427">● Click <b>OK</b> to save the changes and close the configuration window.</li></ul> <p data-bbox="498 440 568 464"><b>Notes:</b></p> <p data-bbox="498 469 1237 581">The values given in the configuration window define the behavior of the island. PDOs are configured in such a way as to transport the island process data. The list of data contained in the PDOs is visible in the <b>I/O Assignment</b> tab of the configuration window.</p>
5	<p data-bbox="498 597 1188 621"><b>Saving the Island and Generating an EDS or DCF Configuration File</b></p> <ul data-bbox="498 626 1098 766" style="list-style-type: none"><li data-bbox="498 626 1098 678">● Select the <b>Save</b> command from the <b>File</b> menu. The *.ISL island file is saved.</li><li data-bbox="498 683 1098 766">● A <b>Generation</b> window appears. Click on <b>YES</b> to generate the EDS or DCF configuration file. The EDS or DCF configuration file is saved.</li></ul>

---

## 6.3 Network Configuration

### Setting the Network Parameters

#### Description

The configuration tool is used to draw diagrams of networks using a graphic representation of the network nodes. It is then used to generate the complete configuration of the network that has been drawn.

It provides access to the various configuration parameters and communication parameters by PDO.

Below is an example of how to use the SyCon configuration tool:

#### Method

Within the PL7 programming software or Unity, launch the SyCon network tool and follow the steps below:

Steps	Actions
1	Open a CANopen type file.
2	Click on "File" and select "Copy EDS".

The screenshot shows the SyCon application window with the 'File' menu open. The 'Copy EDS' option is selected and highlighted in blue. The menu items are: New (Ctrl+N), Open... (Ctrl+O), Close, Save (Ctrl+S), Save As..., Export, Copy EDS, Print... (Ctrl+P), Print Preview, Print Setup..., a list of files (1 D:\document\...\ftm\_v0\_04.co, 2 D:\document\...\ana.co, 3 D:\document\...\ana4-20.co, 4 D:\document\...\500k.pb), and Exit.

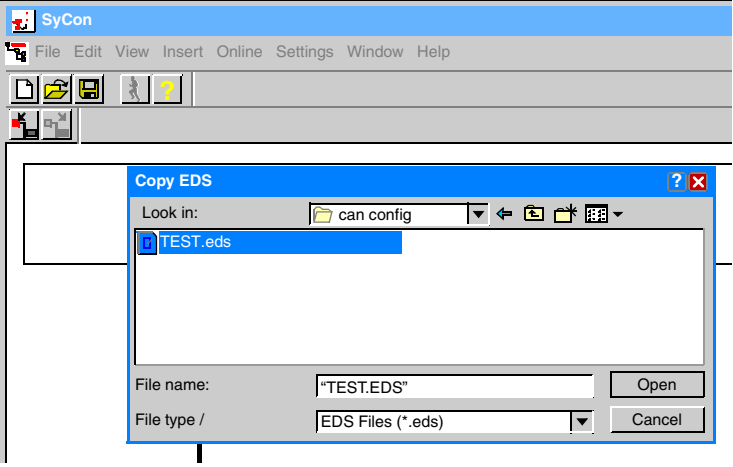
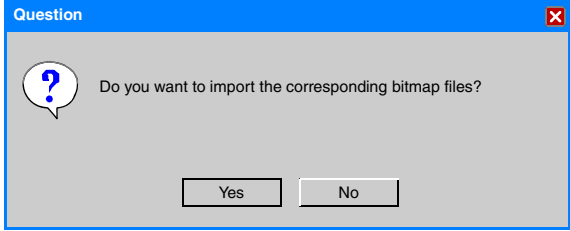
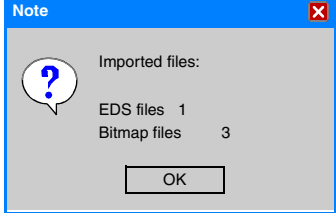
Steps	Actions
3	<p>Select the file to be imported and click on "Open":</p> 
4	<p>Click on "Yes" to import the 3 associated image files.</p> 
5	<p>If the image files are in the same directory as the EDS file, they are found automatically:</p>  <p>Click "OK".</p>

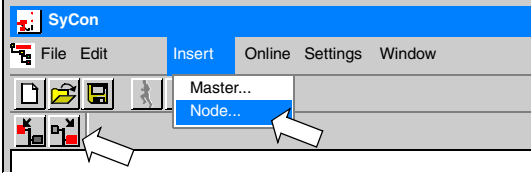
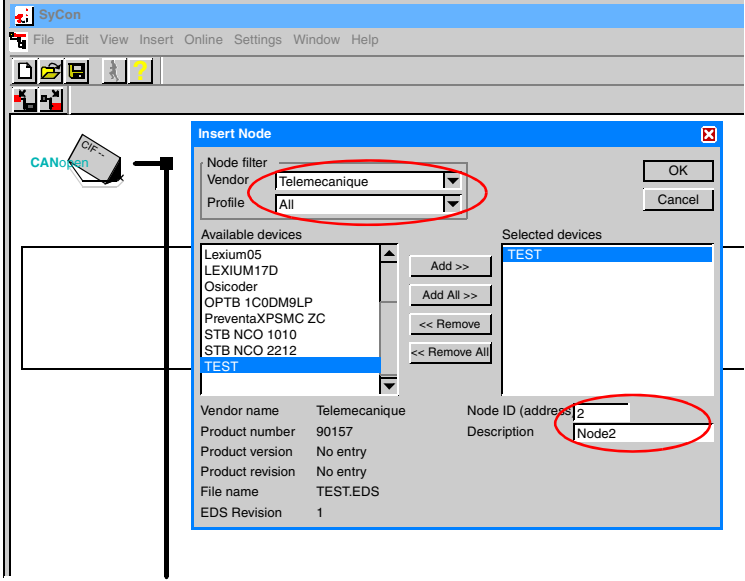
Steps	Actions
6	<p>Click on "Insert" and select "Node" or click on the associated button.</p> 
7	<p>Select the devices to be inserted in the network, enter the node address (given by the rotary switches) and the node description, and click OK:</p>  <p>Note: The name given in the list is the "comment associated with communication block" defined with CANConfig.</p>

**Configuring the PDOs**

Follow the steps below:

Step	Action
1	Double-click on the image of the island to be configured. The configuration window appears.
2	Select a configured PDO and click on "PDO characteristics":

The screenshot shows the 'Node configuration' dialog box in SyCon. The 'Node' field is set to 'TEST' and 'Node address' is '2'. 'Designation' is 'Node2' and 'File name' is 'TEST.EDS'. There are checkboxes for 'Activate node in current configuration' and 'Automatic COB-ID allocation in accordance with Profile 301'. 'Emergency COB-ID' is 129 and 'Nodeguard COB-ID' is 1793. The 'Device profile' is 401 and 'Device type' is 'Analog input, Digital output, Input'. Below these are two tables of PDOs. The 'Configured PDOs' table is as follows:

Obj.Idx.	PDO name	COB-ID	Type	I Addr.	I Len.	O Type	O Addr.	O Len.
1800	Transmit PDO Parameter (Digital)	385	IB	0	2			
1801	Transmit PDO Parameter (Unused)	641	IB	0	1			
1802	Transmit PDO Parameter (Unused)	897	IB	0	0			
1803	Transmit PDO Parameter (Unused)	1153	IB	0	0			
1804	Transmit PDO Parameter (Unused)	1664	IB	0	0			
1805	Transmit PDO Parameter (Unused)	1664	IB	0	0			

The 'PDO Contents Mapping' section on the right includes buttons for 'New receive PDO', 'New transmit PDO', 'Delete configured PDO', and 'Symbolic Names'. The 'Actual node' is set to '1 / Osicoder' and the 'PDO mapping method' is 'DS301 V4'.

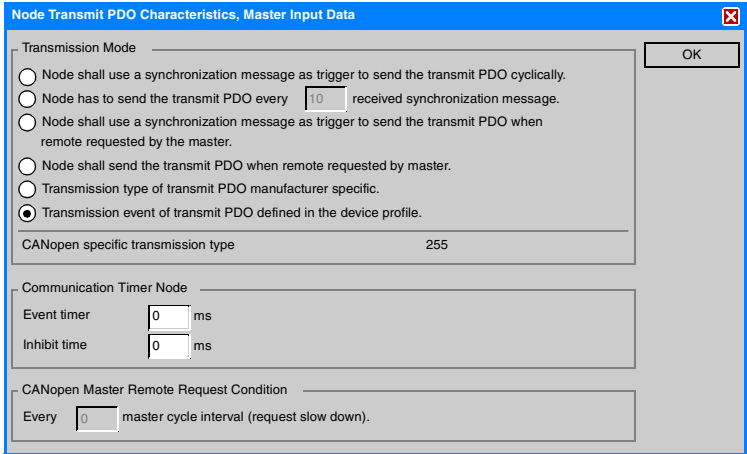
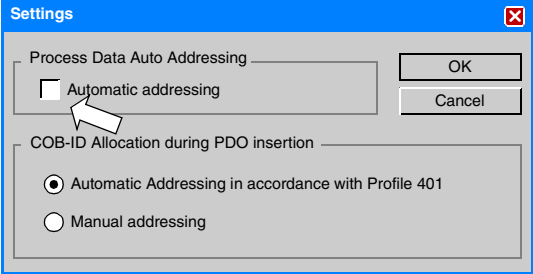
Step	Action
3	<p>Select the required transmission mode and click OK:</p> 
4	<p>If you want to define the addresses of the activated PDOs manually:</p> <ul style="list-style-type: none"> <li>● Select the master,</li> <li>● Click on "Settings" and select "Global settings",</li> <li>● Deselect "Enabled" in the "Process Data Auto Addressing" area,</li> <li>● Click OK.</li> </ul> <p>Illustration</p>  <p>Otherwise, go directly to step 6.</p>

Step	Action																																																																																				
5	<p data-bbox="477 201 1174 253">Enter the required values in the "I Addr" and "O Addr" boxes opposite the activated PDO.</p> <div data-bbox="628 277 1229 808" style="border: 1px solid blue; padding: 5px;"> <p><b>Node Configuration</b></p> <p>Node: TEST      Node address: 2</p> <p>Designation: Node2      Configuration Protocol: Control Error</p> <p>File name: TEST.EDS</p> <p><input checked="" type="checkbox"/> Activate node in current configuration      Emergency COB-ID: 129</p> <p><input type="checkbox"/> Automatic COB-ID allocation in accordance with      Nodeguard COB-ID: 1793</p> <p>Device profile: 401      Device type: Analog input, Digital output, Input</p> <hr/> <p>Predefined Process Data Objects (PDOs) from EDS file</p> <table border="1" data-bbox="642 509 1039 623"> <thead> <tr> <th>Obj.Idx.</th> <th>PDO name</th> <th>Enable</th> </tr> </thead> <tbody> <tr><td>1800</td><td>Transmit PDO Parameter (Digital)</td><td><input checked="" type="checkbox"/></td></tr> <tr><td>1801</td><td>Transmit PDO Parameter (Unused)</td><td><input checked="" type="checkbox"/></td></tr> <tr><td>1802</td><td>Transmit PDO Parameter (Unused)</td><td><input checked="" type="checkbox"/></td></tr> <tr><td>1803</td><td>Transmit PDO Parameter (Unused)</td><td><input checked="" type="checkbox"/></td></tr> <tr><td>1804</td><td>Transmit PDO Parameter (Unused)</td><td><input checked="" type="checkbox"/></td></tr> <tr><td>1805</td><td>Transmit PDO Parameter (Unused)</td><td><input checked="" type="checkbox"/></td></tr> </tbody> </table> <p>Actual node: 1 / Osicoder</p> <p>PDO Mapping method: DS301 V4</p> <p>Add to configured PDOs</p> <hr/> <p>Configured PDOs</p> <table border="1" data-bbox="642 651 1067 786"> <thead> <tr> <th>PDO name</th> <th>Symbolic Name</th> <th>COB-ID</th> <th>Type</th> <th>I Addr</th> <th>I len</th> <th>O Type</th> <th>O Addr</th> <th>O len</th> </tr> </thead> <tbody> <tr><td>Transmit PDO</td><td>PDO_1800</td><td>385</td><td>IB</td><td>0</td><td>2</td><td></td><td></td><td></td></tr> <tr><td>Transmit PDO</td><td>PDO_1801</td><td>641</td><td>IB</td><td>0</td><td>2</td><td></td><td></td><td></td></tr> <tr><td>Transmit PDO</td><td>PDO_1802</td><td>897</td><td>IB</td><td>0</td><td>2</td><td></td><td></td><td></td></tr> <tr><td>Transmit PDO</td><td>PDO_1803</td><td>1153</td><td>IB</td><td>0</td><td>0</td><td></td><td></td><td></td></tr> <tr><td>Transmit PDO</td><td>PDO_1804</td><td>1664</td><td>IB</td><td>0</td><td>0</td><td></td><td></td><td></td></tr> <tr><td>Transmit PDO</td><td>PDO_1805</td><td>1664</td><td>IB</td><td>0</td><td>0</td><td></td><td></td><td></td></tr> </tbody> </table> <p>PDO Contents Mapping</p> <p>PDO Characteristics</p> <p>New receive PDO</p> <p>New transmit PDO</p> <p>Delete configured PDO</p> <p>Symbolic Names</p> </div>	Obj.Idx.	PDO name	Enable	1800	Transmit PDO Parameter (Digital)	<input checked="" type="checkbox"/>	1801	Transmit PDO Parameter (Unused)	<input checked="" type="checkbox"/>	1802	Transmit PDO Parameter (Unused)	<input checked="" type="checkbox"/>	1803	Transmit PDO Parameter (Unused)	<input checked="" type="checkbox"/>	1804	Transmit PDO Parameter (Unused)	<input checked="" type="checkbox"/>	1805	Transmit PDO Parameter (Unused)	<input checked="" type="checkbox"/>	PDO name	Symbolic Name	COB-ID	Type	I Addr	I len	O Type	O Addr	O len	Transmit PDO	PDO_1800	385	IB	0	2				Transmit PDO	PDO_1801	641	IB	0	2				Transmit PDO	PDO_1802	897	IB	0	2				Transmit PDO	PDO_1803	1153	IB	0	0				Transmit PDO	PDO_1804	1664	IB	0	0				Transmit PDO	PDO_1805	1664	IB	0	0			
Obj.Idx.	PDO name	Enable																																																																																			
1800	Transmit PDO Parameter (Digital)	<input checked="" type="checkbox"/>																																																																																			
1801	Transmit PDO Parameter (Unused)	<input checked="" type="checkbox"/>																																																																																			
1802	Transmit PDO Parameter (Unused)	<input checked="" type="checkbox"/>																																																																																			
1803	Transmit PDO Parameter (Unused)	<input checked="" type="checkbox"/>																																																																																			
1804	Transmit PDO Parameter (Unused)	<input checked="" type="checkbox"/>																																																																																			
1805	Transmit PDO Parameter (Unused)	<input checked="" type="checkbox"/>																																																																																			
PDO name	Symbolic Name	COB-ID	Type	I Addr	I len	O Type	O Addr	O len																																																																													
Transmit PDO	PDO_1800	385	IB	0	2																																																																																
Transmit PDO	PDO_1801	641	IB	0	2																																																																																
Transmit PDO	PDO_1802	897	IB	0	2																																																																																
Transmit PDO	PDO_1803	1153	IB	0	0																																																																																
Transmit PDO	PDO_1804	1664	IB	0	0																																																																																
Transmit PDO	PDO_1805	1664	IB	0	0																																																																																

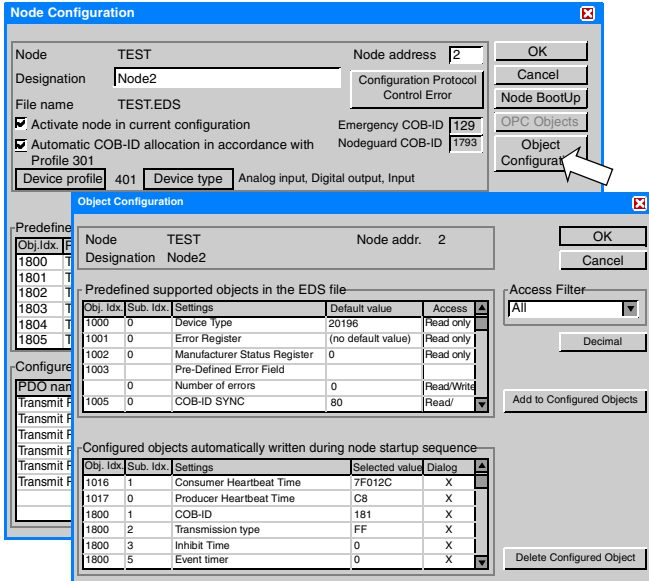

Step	Action
6	<p data-bbox="456 199 755 224">Click on "Object Configuration":</p>  <p data-bbox="456 824 1218 878">This window is used to configure the default values of the configured objects that will be sent to the device the next time the node is powered up.</p> <p data-bbox="456 883 1208 907">For further information on the various objects see <i>The Object Dictionary</i>, p. 131</p>
7	<p data-bbox="456 922 1208 971">Select the objects to be sent to the device, click on "Add to Configured Objects" then click OK.</p>
8	<p data-bbox="456 987 1218 1068">Select "File/Save": A *.CO configuration file is created, which contains the complete network architecture and the initial configuration of each node. This file is used by PLC programming software (e.g. PL7, Unity, etc.).</p>

## 6.4 PLC Programming

---

### Presentation

---

#### Introduction

This chapter describes how to integrate the CANopen network configuration file and configuring under PL7.

---

#### What's in this Section?

This section contains the following topics:

Topic	Page
Integration and Use under PL7	115
Examples of SDO Requests	120

---

## Integration and Use under PL7

### Configuration

Follow the steps below:

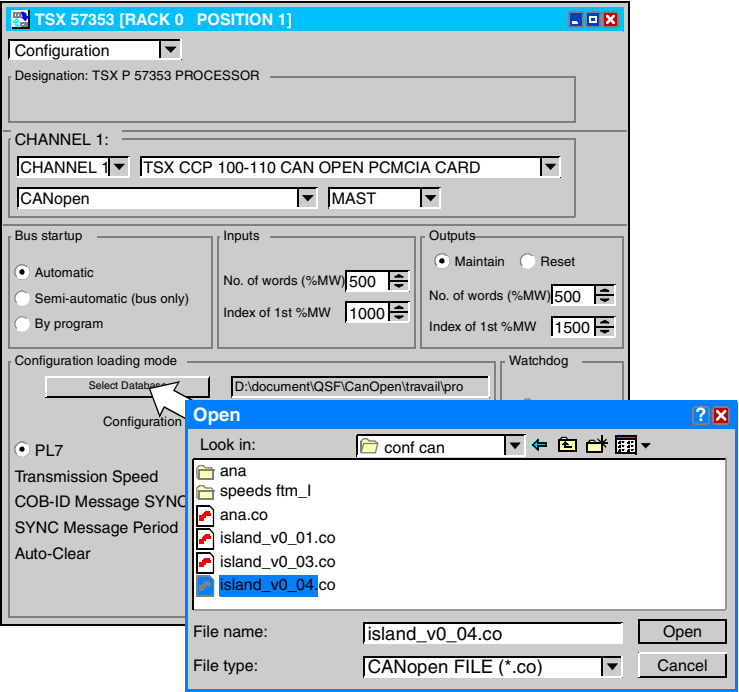
Steps	Actions
1	<p>In the master configuration window, select the network configuration file generated with SYCON:</p> 

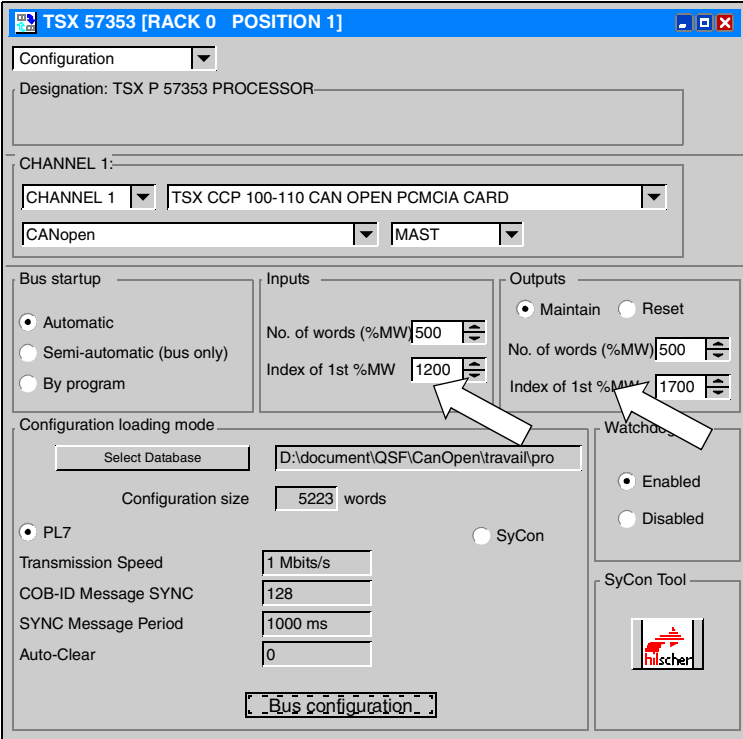
Steps	Actions
2	<p>Complete the fields of the "Input" boxes (input data exchange area) and "Output" boxes (output data exchange area):</p> 

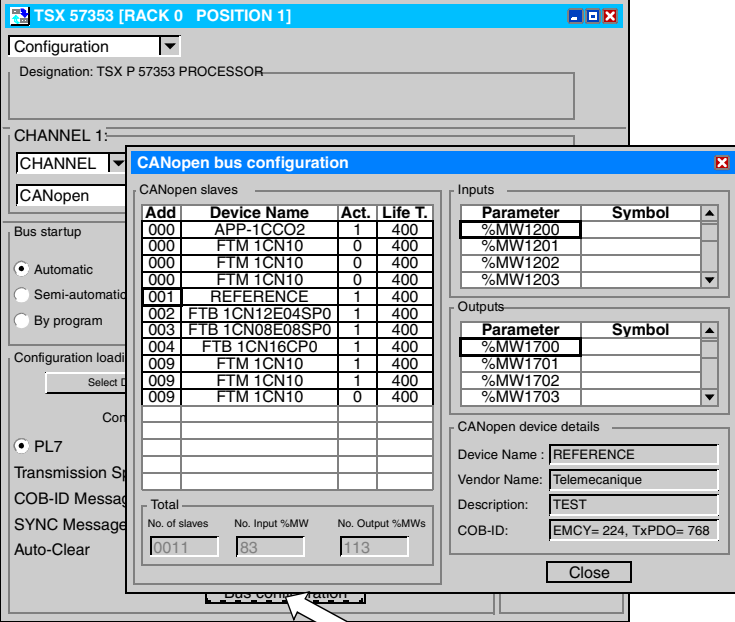
Steps	Actions
3	<p>Click on the "Bus Configuration" button:</p>  <p>The bus configuration window is used to display the exact address of the data associated with the devices.</p> <p>The start address of each PDO is defined by the start address of the exchange area configured using PL7, to which the PDO offset defined using SyCon is added.</p>
4	Execute the required SDO requests (either from the debug screen, or with a program).

**SDO Request from the Debug Screen**

Follow the steps below:

Step	Action																																																						
1	<p>Click on the "Enter request" button in the bottom-right of the debug screen:</p> <p>The screenshot shows the following data in the 'CANopen slave status' table:</p> <table border="1"> <thead> <tr> <th>Addr.</th> <th>Device Name</th> <th>Act.</th> <th>Life T.</th> </tr> </thead> <tbody> <tr><td>000</td><td>APP-1CCO2</td><td>1</td><td>400</td></tr> <tr><td>000</td><td>FTM 1CN10</td><td>0</td><td>400</td></tr> <tr><td>000</td><td>FTM 1CN10</td><td>0</td><td>400</td></tr> <tr><td>000</td><td>FTM 1CN10</td><td>0</td><td>400</td></tr> <tr><td>001</td><td>REFERENCE</td><td>1</td><td>400</td></tr> <tr><td>002</td><td>FTB 1CN12E04SP0</td><td>1</td><td>400</td></tr> <tr><td>003</td><td>FTB 1CN08E08SP0</td><td>1</td><td>400</td></tr> <tr><td>004</td><td>FTB 1CN16CP0</td><td>1</td><td>400</td></tr> <tr><td>009</td><td>FTM 1CN10</td><td>1</td><td>400</td></tr> <tr><td>009</td><td>FTM 1CN10</td><td>1</td><td>400</td></tr> <tr><td>009</td><td>FTM 1CN10</td><td>0</td><td>400</td></tr> </tbody> </table> <p>The 'Total' section shows:</p> <table border="1"> <thead> <tr> <th>No. of slaves</th> <th>No. Input %MW</th> <th>No. Output %MWs</th> </tr> </thead> <tbody> <tr> <td>0011</td> <td>83</td> <td>113</td> </tr> </tbody> </table>	Addr.	Device Name	Act.	Life T.	000	APP-1CCO2	1	400	000	FTM 1CN10	0	400	000	FTM 1CN10	0	400	000	FTM 1CN10	0	400	001	REFERENCE	1	400	002	FTB 1CN12E04SP0	1	400	003	FTB 1CN08E08SP0	1	400	004	FTB 1CN16CP0	1	400	009	FTM 1CN10	1	400	009	FTM 1CN10	1	400	009	FTM 1CN10	0	400	No. of slaves	No. Input %MW	No. Output %MWs	0011	83	113
Addr.	Device Name	Act.	Life T.																																																				
000	APP-1CCO2	1	400																																																				
000	FTM 1CN10	0	400																																																				
000	FTM 1CN10	0	400																																																				
000	FTM 1CN10	0	400																																																				
001	REFERENCE	1	400																																																				
002	FTB 1CN12E04SP0	1	400																																																				
003	FTB 1CN08E08SP0	1	400																																																				
004	FTB 1CN16CP0	1	400																																																				
009	FTM 1CN10	1	400																																																				
009	FTM 1CN10	1	400																																																				
009	FTM 1CN10	0	400																																																				
No. of slaves	No. Input %MW	No. Output %MWs																																																					
0011	83	113																																																					

Step	Action																								
2	<ul style="list-style-type: none"> <li>● Complete the fields:               <ul style="list-style-type: none"> <li>● Request: "Write SDO" or "Read SDO"</li> <li>● Node: address of the device on the CANopen network</li> <li>● Index: index of the object to read or write</li> <li>● Sub-index: sub-index of the object to read or write</li> <li>● Value: entry area for the data to be sent, for write only</li> </ul> </li> <li>● Click "Send".</li> </ul> <p>Here is an example of how to configure the Inhibit Time to 1000 ms:</p> <div data-bbox="581 444 1112 743" style="border: 1px solid blue; padding: 5px;"> <p style="text-align: center; background-color: #0070C0; color: white; margin: 0;"><b>Enter CANopen Request</b> <span style="float: right; color: white;">✖</span></p> <p>Request: <span style="border: 1px solid gray; padding: 2px;">Write SDO</span> ▼</p> <p>Node: <span style="border: 1px solid gray; padding: 2px;">1</span> ⇅</p> <p>Index: 16# <span style="border: 1px solid gray; padding: 2px;">1800</span></p> <p>Sub-index: 16# <span style="border: 1px solid gray; padding: 2px;">3</span></p> <p>Value: 16# <span style="border: 1px solid gray; padding: 2px;">10 27 00 00</span></p> <p style="font-size: small;">(120 bytes max.)</p> <p style="text-align: center; margin-top: 10px;"> <span style="border: 1px solid gray; padding: 5px 15px;">Send</span> <span style="margin-left: 50px; border: 1px solid gray; padding: 5px 15px;">Cancel</span> </p> </div> <p>The value "10 27 00 00" corresponds to the number 2710 in hexadecimal, which is 1000 ms (see <i>Inhibit Time and Event Timer</i>, p. 60).</p>																								
3	<p>After a "Read SDO", read the value given in the "Received response" area in the bottom-right of the debug screen:</p> <div data-bbox="477 878 1212 1036" style="border: 1px solid gray; padding: 5px;"> <table border="1" style="width: 100%; border-collapse: collapse;"> <tr> <td colspan="4" style="text-align: center;">Total</td> <td colspan="2" style="text-align: center;">Slave information</td> </tr> <tr> <td style="width: 15%;">No. of slaves</td> <td style="width: 15%;">No. Input %MW</td> <td style="width: 15%;">No. Output %MWs</td> <td style="width: 15%;"></td> <td colspan="2" style="font-size: small;">Node 10: Status=08h, AddInfo=0001h,</td> </tr> <tr> <td style="text-align: center;">0011</td> <td style="text-align: center;">83</td> <td style="text-align: center;">113</td> <td></td> <td style="text-align: center;">Request to be sent</td> <td style="text-align: center;">Received response</td> </tr> <tr> <td colspan="4"></td> <td style="text-align: center;">Enter request</td> <td style="text-align: center;"> <div style="border: 1px solid gray; padding: 2px; display: inline-block;"> <span style="font-size: 2em;">←</span> </div> </td> </tr> </table> </div>	Total				Slave information		No. of slaves	No. Input %MW	No. Output %MWs		Node 10: Status=08h, AddInfo=0001h,		0011	83	113		Request to be sent	Received response					Enter request	<div style="border: 1px solid gray; padding: 2px; display: inline-block;"> <span style="font-size: 2em;">←</span> </div>
Total				Slave information																					
No. of slaves	No. Input %MW	No. Output %MWs		Node 10: Status=08h, AddInfo=0001h,																					
0011	83	113		Request to be sent	Received response																				
				Enter request	<div style="border: 1px solid gray; padding: 2px; display: inline-block;"> <span style="font-size: 2em;">←</span> </div>																				

## Examples of SDO Requests

### Programmed SDO Request: Example 1

This example gives the program for reading object 1000H. After a request is made, the data obtained is read in the table Diag0:120 (defined below).

#### ***Variables used and parameters of the function***

Variable	Type	Description
Read_sdo	Boolean	Request launch bit.
Index	Word	Index of the object to poll (LSB of the double word "Index_dw").
Sub-index	Word	Sub-index of the object to poll (MSB of the double word "Index_dw").
Slave_add	Word	Address of the slave to poll.
Diag0:120	Word table	Data exchange area.
Status0:4	Word table	Control and exchange status words.
ADR#y.SYS	Immediate value	Master board address.
'SDO'	Character string	Type of SDO object (SDO always in upper case).
Index_dw	Double word	MSB = sub-index. LSB = index.
Node_Id	Word	Word or value identifying the destination device on the CANopen bus.

#### ***Program***

```
Slave_add:=2 (*node at address 2 on the CANopen network*)
```

```
Index:=16#1000; (*index 1000H*)
```

```
Sub_index:=0; (*sub-index 0*)
```

```
IF Read_sdo THEN
```

```
    (*clear control*)
```

```
    Read_sdo:=FALSE;
```

```
    (*Parameter update*)
```

```
    Node_Id:=Slave_add; (*Slave address*)
```

```
    Diag0:120:=16#FFFF; (*Clear diagnostics receive table*)
```

```
    Status2:=0; (*Clear exchange report*)
```

```
    Status3:=6; (*Time-out*)
```



```

(*request*)
READ_VAR(ADR#y.1.SYS, 'SDO', _
Index_dw,Node_Id,Diag0:120,Status1:4);
END_IF;

```

## Programmed SDO Request: Example 2

This example shows the program for saving parameters with object 1010H. The data to be sent is contained in the table Diag0:4 (defined below).

### ***Variables used and parameters of the function***

Variable	Type	Description
Write_sdo	Boolean	Request launch bit.
Index	Word	Index of the object to poll (LSB of the double word "Index_dw").
Sub-index	Word	Sub-index of the object to poll (MSB of the double word "Index_dw").
Slave_add	Word	Address of the slave to poll.
Diag0:120	Word table	Data exchange area.
Status0:4	Word table	Control and exchange status words.
ADR#y.SYS	Immediate value	Master board address.
'SDO'	Character string	Type of SDO object (SDO always in upper case).
Index_dw	Double word	MSB = sub-index. LSB = index.
Node_Id	Word	Word or value identifying the destination device on the CANopen bus.

### ***Program***

```

Slave_add:=2 (*node at address 2 on the CANopen network*)
Index:=16#1000; (*index 1000H*)
Sub_index:=0; (*sub-index 0*)
Diag0:=16#6173; (*'as'*)
Diag0[1]:=16#6576; (*'ev'*)

IF write_sdo THEN
  (*clear control*)
  write_sdo:=FALSE;
  (*Parameter update*)

```

```
Node_Id:=Slave_add; (*Slave address*)
Status2:=0; (*Clear exchange report*)
Status3:=6; (*Time-out*)
(*request*)
WRITE_VAR(ADR#y.1.SYS,'SDO', _
Index_dw,Node_Id,Diag0:4,Status1:4);
END_IF;
```

---

---

# Diagnostics

# 7

---

## Presentation

### Introduction

Diagnostics information simplifies installation and accelerates diagnostics operations.

This chapter provides the information required for analyzing errors and faults. This analysis is done either by:

- LED display or
- CANopen object analysis

### What's in this Chapter?

This chapter contains the following topics:

Topic	Page
Power Supply Diagnostics	124
Field Bus Status Diagnostics LED	125
LED Status Diagnostics for I/O	126
CANopen Objects Diagnostics	127
Behavior in the Event of Short-circuit / Overload / Under-voltage	130

## Power Supply Diagnostics

### Description

The power supply status for the splitter, actuators and sensors is displayed on the splitter box's front panel, by the DO and DI POWER LEDs as indicated in the following diagram (on the left: Plastic unit, on the right: Metal unit).

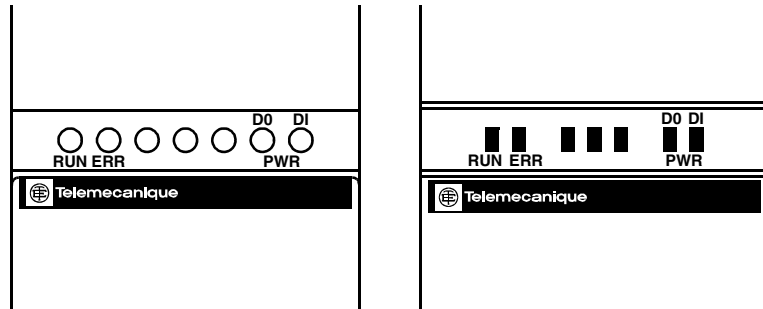

The color of the LED depends on the power supply status, as indicated in the following table:

LED	Description	LED status
DI PWR	Sensor and splitter power supply is unavailable	Off
	Power supply for sensor and splitter OK	Green
	Undervoltage in sensor and splitter power supply	Red
DO PWR	Actuator power supply unavailable	Off
	Actuator power supply is OK	Green
	Under-voltage in actuator power supply	Red

## Field Bus Status Diagnostics LED

### Description of the Display

The CANopen DR 303-3 standard defines the functions of the RUN and ERR LEDs (on the left: Plastic unit, on the right: Metal unit):

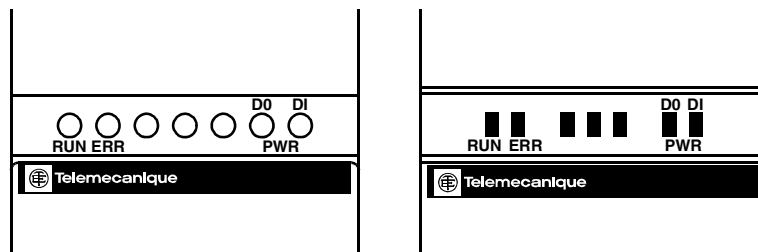

### ERR LED

BUS status	Description	LED status
Auto-Baud	Automatic search for transmission speed in progress	Rapid flashing
No error	Device is operating normally (OK)	Off
Warning limit reached	One of the internal error counters has reached the limit threshold (Error frame)	1 flash
Error control event	Guarding (slave or master) or Heartbeat (user) error	2 flashes
Synchronization error	SYNC signal not received in the SYNC period	3 flashes
Bus is de-activated	Splitter status: Bus off	Permanently switched on

### RUN LED

BUS status	Description	LED status
Auto-Baud	Automatic recognition of transmission speed	Rapid flashing
Stop	Device status: Stopped	1 flash
Pre-operational	Device status: Pre-Operational	Slow flashing
Operational	Device status: Operational	Permanently switched on

## LED Status Diagnostics for I/O

### Status LED for I/Os on the M12 Connectors

One LED is associated with each splitter channel. The LED status depends on the channel configuration and its level (0 or 24 VDC).

The following figure shows the DEL addressing which correspond to the I/Os for plastic units (on left) and metal units (on right):

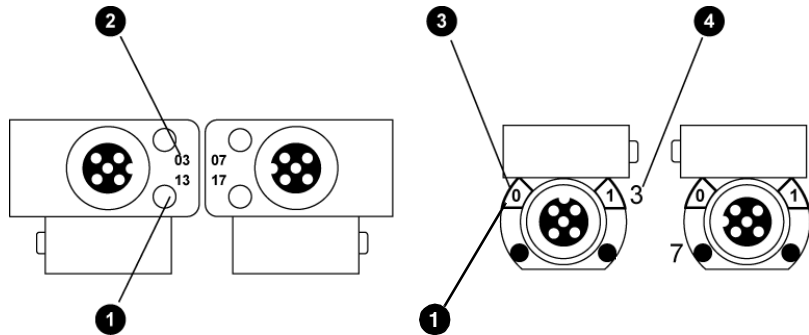

Element	Function
1	LED
2	LED number on the plastic unit
3	Pin number displayed on the metal unit
4	Connector number for the metal unit

### LED Behavior

LED Behavior according to Settings and Channel Status

Channel configuration	Input voltage	Logical value	LED status
Input closing function	0 VDC	0	Off
	24 VDC	1	Yellow
	Channel error	-	Red
Input opening function	0 VDC	1	Off
	24 VDC	0	Yellow
	Channel error	-	Red
Input diagnostics	0 VDC	1	Red
	24 VDC	0	Off
Output	0 VDC	0	Off
	24 VDC	1	Yellow
	Channel error	-	Red

## CANopen Objects Diagnostics

### Description

When an error is detected by the FTB splitter box, the following objects are updated. These objects are described in more detail in the "object dictionary" chapter:

- **The object 1001H, Error Register** displays the generic errors. See Objects dictionary (see *Object 1001H: Error Register, p. 136*)
- **The object 1002H Manufacturer Status Register** displays the errors specific to the FTB splitter box. Objects dictionary (see *Object 1002H: Manufacturer Status Register, p. 137*)
- **The object 1003H, Pre-defined Error Field** saves the latest error codes transmitted by the FTB splitter box. Objects dictionary (see *Object 1003H: Pre-defined Error Field, p. 138*)
- **The object 3000H, Manufacturer Specific Diagnostic** provides information about the status of the FTB splitter box. Objects dictionary (see *Object 3000H: Manufacturer Specific Diagnostic, p. 174*)

### EMCY Message Structure

For each error, the EMCY message is sent by the splitter box that detected the fault via the network (see table structure below).

Once the error has been cleared an EMCY message is sent again, incorporating an "Error code" = 0.

The EMCY message consists of 8 data bytes outlined in the following table:

Byte	0-1	2	3-4	5	6	7
Contents	Error code	Error register	Reserved	Channel 10 to 17 diagnostics	Channel 00 to 07 diagnostics	Manufacturer status register
Corresponding object	1003H	1001H	-	Depends on the type of error. See Channel diagnostics (see <i>Channel Diagnostics (EMCY Bytes 5-6-7), p. 129</i> )		

**Note:** For default configuration and where the user has activated it, the 1805H PDO includes the diagnostics information.

**Error Codes  
(EMCY bytes  
0&1)**

The table below lists the error codes and their meanings:

<b>Error code</b>	<b>Diagnostics</b>	<b>Description</b>
0000H	ERROR_RESET_OR_NO_ERROR	Clearing of one, or all, errors
1000H	GENERIC_ERROR	Internal communication error
2100H	CURRENT_DEVICE_INPUT_SIDE	Detector power supply short-circuit (M12 connector)
2320H	SHORT_CIRCUIT_AT_OUTPUTS	Output short-circuit
3100H	MAINS_VOLTAGE	Splitter power supply voltage < 18V
3120H	INPUT_VOLTAGE_TOO_LOW	Sensor power supply voltage < 18V
3310H	OUTPUT_VOLTAGE_TO_HIGH	Actuator power supply voltage > 30V
3320H	OUTPUT_VOLTAGE_TO_LOW	Actuator power supply voltage < 18V
6101H	SOFTWARE_RX_QUEUE_OVERRUN	The receive buffer has exceeded its internal memory capacity
6102H	SOFTWARE_TX_QUEUE_OVERRUN	The transmit buffer has exceeded its internal memory capacity
8100H	COMMUNICATION	Synchronization, transmit/receive error counter > 96
8120H	CAN_IN_ERROR_PASSIVE_MODE	CAN controller interrupted
8130H	LIFE_GUARD_ERROR	Node-Guarding error
8140H	BUS_OFF	The transmit error counter has exceeded its capacity
9000H	EXTERNAL_ERROR	Detection of wire cut on sensor
F000H	ADDITIONAL_FUNCTION	Actuator voltage < 12VDC



**Status Register  
(EMCY Byte 2)**

The object 1001H (Error Register) is a byte used by the device to display internal errors when an error is detected:

Bit	Description	Comments
0	Generic error	See Object 1003H
1	Current fault (overload or short-circuit)	See Object 1003H
2	Voltage fault	See Object 1003H
3	Temperature	Unchecked
4	Communication error	See Object 1003H
5	Reserved	Unchecked
6	Reserved	Unchecked
7	Specific to the manufacturer	Detection of wire cut on sensor

**Channel  
Diagnostics  
(EMCY Bytes 5-6-7)**

Data returned in bytes 5 and 6 is the image of channels with the error defined by EMCY byte 7 (manufacturer status register):

Byte	6 (channels 0 to 7)	5 (channels 10 to 17)	7
Contents	Faulty channels	Faulty channels	Types of faults

The following table indicates the assignment of all EMCY byte 7 bits:

Bit	Description	Comments
0	Sensor under voltage	< 18V
1	No voltage in sensor	< 12V
2	Actuator under voltage	< 18V
3	No voltage in actuator	< 12V
4	Sensor power supply short-circuit	< 12V
5	Actuator short-circuit	only where output is set-up
6	Actuator overload	only where output is set-up
7	Detection of wire cut on sensor	-

## Behavior in the Event of Short-circuit / Overload / Under-voltage

---

### Power Supply for Splitter Boxes and Sensors

#### ***Short-circuit / overload***

The following consequences on the FTB splitter box occur when the sensor power supply experiences a short-circuit or overload:

- The diagnostics LED on the corresponding M12 connector lights up red,
- corresponding diagnostics data is transmitted to the master via the bus,
- all other inputs and outputs will continue to operate correctly.

Disconnecting the M12 connector of the faulty channel results in LED and diagnostics data re-initialization.

#### ***Under-voltage / no voltage***

There are three under-voltage detection levels:

- $12 \text{ VDC} \leq U < 18 \text{ VDC}$ : in this case, the splitter box still operates, however:
  - the DI-POWER LED is red,
  - appropriate diagnostics data is sent to the master via the bus
- $7 \text{ VDC} \leq U < 12 \text{ VDC}$ : in this case, the I/Os no longer operate, however bus communication remains operational:
  - the DI-POWER LED is switched off,
  - the relevant diagnostics data is sent to the master via the bus.
- $U < 7 \text{ VDC}$  : in this case, the splitter no longer operates.

**Note:** Power supply to the sensor and the Advantys FTB splitter box is provided by the M12 connectors between pins 1 (+24 VDC) and 3 (0 VDC).

---

### Actuators

#### ***Short-circuit / overload***

The following consequences on the FTB splitter box occur when an output experiences a short-circuit or overload:

- The diagnostics LED on the corresponding M12 connector lights up red,
- the output status LED lights up red.
- the corresponding diagnostics data is transmitted to the master via the bus.

To be re-activated, a default output must be set to 0 after clearing the error.

#### ***Under-voltage / no voltage***

There are two under-voltage detection levels:

- $12 \text{ VDC} \leq U < 18 \text{ VDC}$ : in this case, the splitter box still operates, however:
  - the DO-POWER LED is red,
  - the relevant diagnostics data is sent to the master via the bus.
- $U < 12 \text{ VDC}$ :
  - the DO-POWER LED switches off,
  - the relevant diagnostics data is sent to the master via the bus.

---

# The Object Dictionary



---

## Presentation

### Introduction

This chapter provides a description of the object dictionary, the list of objects concerning the communication profile, the hardware profile and the specific manufacturer zone, with a detailed description of each.

### What's in this Chapter?

This chapter contains the following sections:

Section	Topic	Page
8.1	The Object Dictionary	133
8.2	Objects of the Communication Profile 1000H to 1FFFH	134
8.3	Manufacturer-specific Zone Objects 2000H to 5FFFH	171
8.4	Hardware Profile Objects 6000H to 9FFFH	175

---



## 8.1 The Object Dictionary

### The Object Dictionary

#### Index Ranges

There are three zones in the object dictionary:

Index (hexadecimal)	Zone	Function	Documentation
1000-1FFF	Communication profile zone	Communication capacities	<i>Objects of the Communication Profile 1000H to 1FFFH , p. 134</i>
2000-5FFF	Manufacturer-specific zone	Diagnostics information, some I/O data	<i>Manufacturer-specific Zone Objects 2000H to 5FFFH, p. 171</i>
6000-9FFF	Device-specific profile zone	I/O data	<i>Hardware Profile Objects 6000H to 9FFFH , p. 175</i>

It is possible to map manufacturer-specific and device-specific objects in the PDO objects, which are then sent via the product.

## 8.2 Objects of the Communication Profile 1000H to 1FFFH

### At a Glance

#### Introduction

This section lists the objects relating to the communication profile. Each object, with all its technical characteristics, is described according to the CANopen standard.

#### What's in this Section?

This section contains the following topics:

Topic	Page
Object 1000H: Device Type	135
Object 1001H: Error Register	136
Object 1002H: Manufacturer Status Register	137
Object 1003H: Pre-defined Error Field	138
Object 1005H: COB-ID SYNC Message	140
Object 1006H: Communication Cycle Period	141
Object 1008H: Manufacturer Device Name	142
Object 100AH: Manufacturer Software Version (MSV)	143
Object 100CH: Guard Time	144
Object 100DH: Life Time Factor	145
Object 1010H: Store Parameters	146
Object 1011H: Restore Default Parameters	148
Object 1014H: COB-ID Emergency Message (EMCY)	150
Object 1016H: Consumer Heartbeat Time	151
Object 1017H: Producer Heartbeat Time	152
Object 1018H: Identity Object	153
Object 1200H: Server SDO Parameter	154
Object 1400H: 1st Receive PDO Communication Parameter	155
Object 1405H: 2nd Receive PDO Communication Parameter	156
Object 1600H: 1st Receive PDO Mapping Parameter	157
Object 1605H: 2nd Receive PDO Mapping Parameter	159
Object 1800H: 1st Transmit PDO Communication Parameter	161
Object 1805H: 2nd Transmit PDO Communication Parameter	164
Object 1A00H: 1st Transmit PDO Mapping Parameter	167
Object 1A05H: 2nd Transmit PDO Mapping Parameter	169

## Object 1000H: Device Type

### Description

This object indicates the device type and its functionalities.

The least significant word indicates the profile number (401 or 191H, for CANopen standard inputs / outputs).

The most significant word is known as the "additional information" and provides details of the device's functionalities:

Bit	Valid if bit = 1
0	The device has discrete inputs
1	The device has discrete outputs
2	The device has analog inputs
3	The device has analog outputs

Splitter box	Hexadecimal code	Decimal code
FTB 1CN16EP0	010191H	65 937
FTB 1CN16EM0	010191H	65 937
FTB 1CN16CP0	030191H	197 009
FTB 1CN16CM0	030191H	197 009
FTB 1CN08E08SP0	030191H	197 009
FTB 1CN08E08CM0	030191H	197 009
FTB 1CN12E04SP0	030191H	197 009

### Characteristics

The characteristics of this object are outlined in the following table:

Sub-index	Description	Data type	Default value	Access	PDO Mapping	Backed up
-	-	UNSIGNED32	See list	ro	no	no

## Object 1001H: Error Register

---

### Description

This object is used by the device to display internal faults. When a fault is detected, the corresponding bit is therefore activated.

The following faults can be displayed:

Bit	Meaning	Comments
0	Generic error	-
1	Current fault (overload or short-circuit)	-
2	Voltage fault	-
3	Temperature	Unchecked
4	Communication error	-
5	Reserved	Unchecked
6	Reserved	Unchecked
7	Specific to the manufacturer	Detection of wire cut

---

### Characteristics

The characteristics of this object are given in the following FTB splitter box table:

Sub-index	Description	Data type	Default value	Access	PDO Mapping	Backed up
-	-	UNSIGNED8	-	ro	no	no

---



## Object 1002H: Manufacturer Status Register

**Description** The diagnostics data is saved in this 32-bit field.  
The least significant word (LSW) contains the error code.

**Characteristics** The characteristics of this object are outlined in the following table:

Sub-index	Description	Data type	Default value	Access	PDO Mapping	Backed up
0	-	UNSIGNED32	80H (see note)	ro	no	no

**Note:** At initial start-up, channels 10 to 17 are configured as "diagnostics inputs" by default.

### Assignment of Bits

**Note:** Bit Values:

- 0: no fault
- 1: fault

The following table indicates the assignment of the 32 bit set:

Bit	Meaning	Notes
0	Sensor under voltage < 18V	
1	No voltage in sensor < 12V	
2	Actuator under voltage < 18V	
3	No voltage in actuator < 12V	
4	Sensor power supply short-circuit in M12	
5	Actuator short-circuit	Only where output is set-up
6	Actuator warning	Only where output is set-up
7	Detection of wire cut	
8 to 31	Reserved	

## Object 1003H: Pre-defined Error Field

### Description

This object is a double word used to store the most recent faults, as well as their characteristics:

- The Error Code is stored to the least significant word.
- The sub-index 0 contains the number of stored errors.

### Characteristics

The characteristics of this object are outlined in the following table:

Sub-index	Description	Data type	Default value	Access	PDO Mapping	Backed up
0	Number of stored errors	UNSIGNED8	0	rw	no	no
1	Most recent error	UNSIGNED32	-	ro	no	no
2	Second to last error	UNSIGNED32	-	ro	no	no
...						
10						

### Appearance of a New Fault

When a new fault appears, the codes already present are moved into the upper level sub-indexes: the fault in sub-index 1 is moved to sub-index 2, the fault in sub-index 2 is moved to sub-index 3, the fault in sub-index 10 disappears.

### Clearing Faults

The fault code history can only be cleared by writing the value 0 in the sub-index 0 of object 1003H.

**Note:** Clearing a fault does not delete the error code from the Predefined Error Field (PEF).

### Indicating Faults

All faults are indicated by the sending of an "Emergency" message (EMCY message). Once the source of the fault has been cleared, an EMCY message with the No-error content is sent (Error-Code 0000H).

**Error Code Meanings**

The table below lists the error codes and their meanings:

Error code	Diagnostics	Meaning
0000H	ERROR_RESET_OR_NO_ERROR	Clearing of one, or all, errors
1000H	GENERIC_ERROR	Internal communication error
2100H	CURRENT_DEVICE_INPUT_SIDE	Sensor power supply short-circuit (M12 connector)
2320H	SHORT_CIRCUIT_AT_OUTPUTS	Output short-circuit
3100H	MAINS_VOLTAGE	Sensor/splitter box voltage is lower than approximately 12V
3120H	INPUT_VOLTAGE_TOO_LOW	Splitter box has detected under-voltage in the sensor
3310H	OUTPUT_VOLTAGE_TOO_HIGH	Splitter box has detected over-voltage in the actuator
3320H	OUTPUT_VOLTAGE_TOO_LOW	The splitter box has detected under-voltage in the actuator (see note)
6101H	SOFTWARE_RX_QUEUE_OVERRUN	The receive buffer has exceeded its internal memory capacity
6102H	SOFTWARE_TX_QUEUE_OVERRUN	The transmit buffer has exceeded its internal memory capacity
8100H	COMMUNICATION	Synchronization, transmit/receive error counter > 96
8120H	CAN_IN_ERROR_PASSIVE_MODE	CAN controller interrupted
8130H	LIFE_GUARD_ERROR	Node-Guarding error
8140H	BUS_OFF	The CAN frame error counter has exceeded its capacity
9000H	EXTERNAL_ERROR	Detection of wire cut
F000H	ADDITIONAL_FUNCTION	Actuator voltage is lower than approximately 12V

**Note:** When there are no set outputs, there are no associated messages. The state of the DO POWER LED is not significant. *CANopen Objects Diagnostics, p. 127*

## Object 1005H: COB-ID SYNC Message

---

**Description** This object contains the synchronization message identifier.

---

**Object Characteristics** The characteristics of this object are outlined in the following table:

Sub-index	Description	Data type	Default value	Access	PDO Mapping	Backed up
0	-	UNSIGNED32	80H	rw	no	yes

---

---

## Object 1006H: Communication Cycle Period

---

### Description

This object describes the time interval between two SYNC signals in microseconds. This interval must be at least 10 ms with a minimum increment of 1ms. The entry must be a double word.

If a value between 10,000 and 10,000,000 is entered, the splitter must receive a SYNC signal within this time interval. If not, it switches to "Pre-Operational" status. Maximum tolerance is 1% of the configured value. Monitoring of elapsed times starts when the first SYNC signal is received.

---

### Object Characteristics

The characteristics of this object are outlined in the following table:

Sub-index	Description	Data type	Default value	Access	PDO Mapping	Backed up
0	-	UNSIGNED32	0	ro	no	no

**Note:** It is not advisable to use this object as it can create communication errors in slow speed.

---

## Object 1008H: Manufacturer Device Name

---

**Description** This object contains the device name.

---

**Object Characteristics** The characteristics of this object are outlined in the following table:

Sub-index	Description	Data type	Default value	Access	PDO Mapping	Backed up
0	-	STRING	See the table below	ro	no	no

The default value depends on the splitter box reference:

Splitter box references	Default values
FTB 1CN08E08SP0	FTB1CN08E08SP0
FTB 1CN12E04SP0	FTB1CN12E04SP0
FTB 1CN16EP0	FTB1CN16EP0
FTB 1CN16EM0	FTB1CN16EM0
FTB 1CN16CP0	FTB1CN16CP0
FTB 1CN16CM0	FTB1CN16CM0
FTB 1CN08E08CM0	FTB1CN08E08CM0

(see *Splitter Box Inputs and Outputs*, p. 12)

---

---

## Object 100AH: Manufacturer Software Version (MSV)

---

**Description** This object contains details of the device software version, in the form 'SWxx.yy'.

---

**Object Characteristics** The characteristics of this object are outlined in the following table:

Sub-index	Description	Data type	Default value	Access	PDO Mapping	Backed up
0	-	STRING	Depending on the splitter box version	ro	no	no

---

## Object 100CH: Guard Time

---

**Description** The object 100CH contains the "Guard-Time" parameter expressed in milliseconds. See *"Node-Guarding" and "Life-Guarding" Monitoring Protocols, p. 62.*

---

**Object Characteristics** The characteristics of this object are outlined in the following table:

Sub-index	Description	Data type	Default value	Access	PDO Mapping	Backed up
0	-	UNSIGNED16	0	rw	no	yes

Common typical values for the "Guard-Time" parameter lie between 250 ms and 2s.

---



## Object 100DH: Life Time Factor

**Description** This object contains the "Life-Time-Factor" parameter. It is used to calculate the "Life-Time".

**Object Characteristics** The characteristics of this object are outlined in the table below: *"Node-Guarding" and "Life-Guarding" Monitoring Protocols, p. 62*

Sub-index	Description	Data type	Default value	Access	PDO Mapping	Backed up
0	-	UNSIGNED8	0	rw	no	yes

### Reliable Operation

To enable reliable and secure operation, the user must enter a "Life-Time-Factor" with a minimum value of 2.

When the value 1 is used, should a delay occur due to the processing of high priority messages or internal processing on the "Node-Guarding" master, the splitter switches back to the "Pre-Operational" default state without generating any errors.

### WARNING

#### RISK OF UNINTENDED DEVICE OPERATION

Set the "Life-Time-Factor" to a minimum value of 2 to prevent any inadvertent change of state to "Pre-Operational" state. Depending on the I/O configuration, an inadvertent change of state may result in unintended device operation.

**Failure to follow this instruction can result in death, serious injury, or equipment damage.**

## Object 1010H: Store Parameters

**Description** This object is used to store the parameters of the splitter box in backed up memory.

**Characteristics** The characteristics of this object are outlined in the following table:

Sub-index	Description	Data type	Default value	Access	PDO Mapping	Backed up
0	Sub-index number	UNSIGNED8	4	ro	no	no
1	Store all parameters	UNSIGNED32	-	rw	no	no
2	Store communication parameters (1000H–1FFFH)	UNSIGNED32	-	rw	no	no
3	Store standardized application parameters (6000H–9FFFH)	UNSIGNED32	-	rw	no	no
4	Store manufacturer-specific application parameters (2000H–5FFFH)	UNSIGNED32	-	rw	no	no

### Operation

To save the parameters, the "save" ASCII character string (6576 6173H) must be written to the corresponding sub-index:

	Most significant word		Least significant word	
Hex value	65H	76H	61H	73H
ISO 8859 (ASCII) signature	e	v	a	s

The read result of a sub-index is always 0000 0001H.

**Back-up  
Behavior*****Writing a valid value***

The device stores the parameters, and then confirms SDO transmission (downloading initialization response).

**Note:** When storage fails, the splitter box returns an Abort SDO Transfer (Abort Code:0606 0000H).

***Writing an invalid value***

The device refuses storage and replies with an "Abort SDO Transfer" (Abort Code:0800 002xH with x=0...F).

## **WARNING**

**RISK OF UNINTENDED EQUIPMENT OPERATION**

The splitter box must be switched to the "Pre-Operational" state to save its configuration. The saving process takes 1 to 2 seconds. If the save takes place in the "Operational" state, the outputs will not be updated during the saving process.

**Failure to follow this instruction can result in death, serious injury, or equipment damage.**

**Storage Function**

During read access to an appropriate sub-index, the splitter box transmits information on its storage function, in the following format:

Bit	32 to 2	1	0
Meaning if bit = 0	Reserved	The splitter box does not store parameters autonomously	The splitter box does not store parameters when it receives a command
Meaning if bit = 1	Reserved	The splitter box stores parameters autonomously	The splitter box stores parameters when it receives a command

## Object 1011H: Restore Default Parameters

**Description** This object is used to restore the FTB splitter box's "factory" settings.

**Characteristics** The characteristics of this object are outlined in the following table:

Sub-index	Description	Data type	Default value	Access	PDO Mapping	Backed up
0	Sub-index number	UNSIGNED8	4	ro	no	no
1	Restore all default parameters.	UNSIGNED32	-	rw	no	no
2	Restore default communication parameters (1000H–1FFFH).	UNSIGNED32	-	rw	no	no
3	Restore default standardized application parameters (6000H–9FFFH).	UNSIGNED32	-	rw	no	no
4	Restore default manufacturer-specific application parameters (2000H–5FFFH).	UNSIGNED32	-	rw	no	no

### Operation

To restore the parameters, the "load" ASCII character string (64616F6CH) must be written to the corresponding sub-index:

	Most significant word		Least significant word	
	ISO 8859 (ASCII) signature	d	a	o
Hex value	64H	61H	6FH	6CH

The read result of a sub-index is always 0000 0001H.

**Restoration  
Behavior*****Writing a valid value***

The device stores the default parameters, and then confirms SDO transmission (downloading initialization response).

***Writing an invalid value***

The device refuses storage and replies with an Abort SDO Transfer (abort code:0800 002xH in which x=0...F).

The default values are actually only used when:

- the splitter box has been reset
  - the reset node command has been launched (after initialization by sub-indexes 1, 3 or 4)
  - the reset communication command has been launched (after initialization by sub-index 2)
-

## Object 1014H: COB-ID Emergency Message (EMCY)

---

**Description** This object contains the EMCY emergency message identifier.

---

**Object Properties** The characteristics of this object are outlined in the following table:

Sub-index	Description	Data type	Default value	Access	PDO Mapping	Backed up
0	-	UNSIGNED32	80H + NODE-ID	rw	no	yes

---

## Object 1016H: Consumer Heartbeat Time

### Description

This object is used to monitor the communication of another product on the network. It is particularly used to monitor the master. The value of this object defines the time interval within which the monitored product must send a Heartbeat message.

The splitter box is designed in such a way that it can only monitor one product at a time.

The value of this object must be greater than the value of object 1017H of the monitored product.

The time must be a multiple of 1 ms.

### Object Characteristics

The characteristics of this object are outlined in the following table:

Sub-index	Description	Data type	Default value	Access	PDO Mapping	Backed up
0	Sub-index number	UNSIGNED8	1	ro	no	yes
1	Consumer heartbeat time	UNSIGNED32	0	rw	no	yes

### Content of Variable

The content of sub-index 1 is as follows:

Bit	31 to 24	23 to 16	15 to 0
Value	0H (Reserved)	Address of the monitored splitter box	Monitoring time in ms

If the value of the sub-index is 0, no splitter box is monitored.

*"Node-Guarding" and "Life-Guarding" Monitoring Protocols, p. 62*

## Object 1017H: Producer Heartbeat Time

---

**Description** This object is used to configure the time interval in ms within which the module must produce the Heartbeat message.

The default monitoring method of the splitter is "Node Guarding". If a non-zero value is written in this object the Heartbeat mechanism is used.

---

**Object Characteristics** The characteristics of this object are outlined in the following table:

Sub-index	Description	Data type	Default value	Access	PDO Mapping	Backed up
0	-	UNSIGNED16	0H	rw	no	yes

If the Heartbeat error monitoring protocol is selected, the splitter box sends a Heartbeat message periodically, depending on the "Producer Heartbeat Time" parameter. The products responsible for monitoring this message (Heartbeat Consumer) generate a Heartbeat event if the message is not received within the configured time (Consumer Heartbeat Time) in their object 1016H. *"Node-Guarding" and "Life-Guarding" Monitoring Protocols, p. 62*

---



## Object 1018H: Identity Object

### Description

This object contains information about the splitter box. It indicates the manufacturer's CiA identifier (vendor ID), the product code and the splitter box revision numbers (revision number).

The revision information is coded in two parts:

- the major revision part (most significant word) indicates an evolution in CANopen functionalities,
- the minor revision part (least significant word) indicates an evolution in splitter functionalities only.

### Characteristics

The characteristics of this object are outlined in the following table:

Sub-index	Description	Data type	Default value	Access	PDO Mapping	Backed up
0	Sub-index number	UNSIGNED8	3H	ro	no	no
1	Vendor ID	UNSIGNED32	0500 005AH	ro	no	no
2	Product code	UNSIGNED32	See the table below	ro	no	no
3	Revision number	UNSIGNED32	-	ro	no	no

### Default Value of Sub-index 2

The default values of sub-index 2 are given in the table below:

Reference	Object code
FTB 1CN16EP0	9D4FH
FTB 1CN16EM0	E174H
FTB 1CN08E08CM0	E175H
FTB 1CN08E08SP0	9D51H
FTB 1CN12E04SP0	9D50H
FTB 1CN16CP0	CA49H
FTB 1CN16CM0	E176H

## Object 1200H: Server SDO Parameter

---

**Description** This object contains the message identifiers for SDO communication.

---

**Object Characteristics** The characteristics of this object are outlined in the following table:

Sub-index	Description	Data type	Default value	Access	PDO Mapping	Backed up
0	Sub-index number	UNSIGNED8	2H	ro	no	no
1	Client to Server	UNSIGNED32	600H + Node ID	ro	no	no
2	Server to Client	UNSIGNED32	580H + Node ID	ro	no	no

---

## Object 1400H: 1st Receive PDO Communication Parameter

**Description** This object contains the receive PDO identifier.

**Object Characteristics** The characteristics of this object are outlined in the following table:

Sub-index	Description	Data type	Default value	Access	PDO Mapping	Backed up
0	Sub-index number	UNSIGNED8	2H	ro	no	yes
1	COB-ID	UNSIGNED32	0000 0200H + Node ID	rw	no	yes
2	Transmission mode	UNSIGNED8	FFH (255 Dec)	rw	no	yes

**Transmission Mode** The PDO transmission mode can be configured as described in the table below.

Transfer code		Transmission mode				Notes
Dec.	Hex.	Cyclic	Acyclic	Synchronous	Asynchronous	
0	0		x	x		Send PDO on first SYNC message following an event
1 to 240	1 to F0	x		x		Send PDO every x SYNC messages
241 to 251	F1 to FB	Reserved				-
252 to 253	FC to FE	Reserved				-
254 to 255	FE to FF				x	Send PDO on event

**Note:** For modes 254 and 255, the event triggering the send is defined by the message producer.

## Object 1405H: 2nd Receive PDO Communication Parameter

**Description** This object contains the receive PDO identifier.

**Characteristics** The characteristics of this object are outlined in the following table:

Sub-index	Description	Data type	Default value	Access	PDO Mapping	Backed up
0	Sub-index number	UNSIGNED8	2H	ro	no	yes
1	COB-ID	UNSIGNED32	0000 0300H + Node-ID	rw	no	yes
2	Transmission mode	UNSIGNED8	FFH (255 Dec)	rw	no	yes

**Transmission Mode** The PDO transmission mode can be configured as described in the table below.

Transfer code		Transmission mode				Notes
Dec.	Hex.	Cyclic	Acyclic	Synchronous	Asynchronous	
0	0		x	x		Send PDO on first SYNC message following an event
1 to 240	1 to F0	x		x		Send PDO every x SYNC messages
241 to 251	F1 to FB	Reserved				-
252 to 253	FC to FE	Reserved				-
254 to 255	FE to FF				x	Send PDO on event

**Note:** For modes 254 and 255, the event triggering the send is defined by the message producer.

## Object 1600H: 1st Receive PDO Mapping Parameter

**Description** This object is used to describe the objects that will be transported by the first PDO.

**Characteristics** The characteristics of this object are outlined in the following table:

Sub-index	Description	Data type	Default value	Access	PDO Mapping	Backed up
0	Sub-index number	UNSIGNED8	See table	rw	no	yes
1	1st object in the PDO	UNSIGNED32	See table	rw	no	yes
2	2nd object in the PDO	UNSIGNED32	See table	rw	no	yes
...						
8	Most recent object in PDO	UNSIGNED32	See table	rw	no	yes

### Sub-index Structure

Each data object to be transported is represented in the following manner:

Bits	31 to 16 (MSB)	15 to 8	7 to 0 (LSB)
Data	Index number of object to be transported	Sub-index number of object to be transported	Length of object to be transported
Example	6200H	01H	08H

**Note:**

- The maximum total length of data that can be transported (08H maximum) by the PDO is 8 bytes.
- By default, object 1600H is always configured on object 6200H. By default, the first PDO transports object 6200H.

**Default Values**

The following table gives the default value of object 1600H depending on the splitter reference:

<b>Product references</b>	<b>Sub-index</b>	<b>Default value</b>
FTB 1CN08E08SP0	0	1
FTB 1CN08E08CM0 FTB 1CN12E04SP0	1	6200 0108H
FTB 1CN16C•0	0	2
	1	6200 0108H
	2	6200 0208H
FTB 1CN16E•0	0	-

---

## Object 1605H: 2nd Receive PDO Mapping Parameter

**Description** This object is used to describe the objects that will be transported by the second PDO.

**Characteristics** The characteristics of this object are outlined in the following table:

Sub-index	Description	Data type	Default value	Access	PDO Mapping	Backed up
0	Sub-index number	UNSIGNED8	See table	rw	no	yes
1	1st object in the PDO	UNSIGNED32	See table	rw	no	yes
2	2nd object in the PDO	UNSIGNED32	See table	rw	no	yes
...						
8	Most recent object in PDO	UNSIGNED32	See table	rw	no	yes

### Sub-index Structure

Each data object to be transported is represented in the following manner:

Bits	31 to 16 (MSB)	15 to 8	7 to 0 (LSB)
Data	Index number of object to be transported	Sub-index number of object to be transported	Length of object to be transported
Example	2000H	01H	08H

**Note:**

- The maximum total length of data that can be transported by the PDO is 8 bytes.
- By default, the 2nd PDO transports objects 2000H and 2001H for the configurable splitters.

**Default Values**

The following table gives the default value of object 1605H depending on the splitter reference:

<b>Product references</b>	<b>Sub-index</b>	<b>Default value</b>
FTB 1CN08E08SP0 FTB 1CN12E04SP0 FTB 1CN16•0	0	1
	1	2000 0108H
FTB 1CN08E08CM0	0	2
	1	2000 0108H
	2	2001 0108H
FTB 1CN16CP0 FTB 1CN16CM0	0	3
	1	2000 0108H
	2	2001 0108H
	3	2001 0208H

---



---

## Object 1800H: 1st Transmit PDO Communication Parameter

---

**Description** This object contains the PDO transmit identifier.

---

**Characteristics** The characteristics of this object are outlined in the following table:

Sub-index	Description	Data type	Default value	Access	PDO Mapping	Backed up
0	Sub-index number	UNSIGNED8	5H	ro	no	yes
1	COB-ID	UNSIGNED32	0000 0180H + Node ID	rw	no	yes
2	Transmission mode	UNSIGNED8	FFH (255 dec.)	rw	no	yes
3	Inhibit Time	UNSIGNED16	0	rw	no	yes
4	Not available					
5	Event Timer	UNSIGNED16	0	rw	no	yes

---

**Transmission Mode** The PDO transmission mode can be configured as described in the table below.

Transfer code		Transmission mode					Notes
Dec.	Hex.	Cyclic	Acyclic	Synchronous	Asynchronous	RTR only	
0	0		x	x			Send PDO on first SYNC message following an event
1 to 240	1 to F0	x		x			Send PDO every x SYNC messages
241 to 251	F1 to FB	Reserved					-
252	FC			x		x	Receive SYNC message and send PDO on Remote Request
253	FD				x	x	Update data and send PDO on Remote Request
254 to 255	FE to FF				x		Send PDO on event (Change of state mode)

**Note:** For transmission modes corresponding to transfer codes 254 and 255, the events that trigger a TPDO transmission are:

- modification of transported data status,
- the Event Timer has elapsed.

### COB-ID Structure

The structure of a COB-ID for CAN2.0 is shown in the following table:

Bit No.	Value	Meaning
31 (MSb)	0	The PDO object exists
	1	The PDO object does not exist
30	0	RTR mechanism authorized
	1	RTR mechanism not authorized
29	0	11-Bit ID (CAN 2.0A)
28 - 11	0	if bit 29 = 0
10 - 0 (LSb)	X	Bit 10 - 0 of the identifier

### Inhibit Time (Sub-index 3)

In the case of PDO transmission (Transmit PDO), the Inhibit Time can be entered in this 16-bit field. After data has been changed, the PDO sender checks that an Inhibit Time has expired since the last transmission. A new PDO transmission can only take place if the Inhibit Time has expired. The Inhibit Time is useful for asynchronous transmission (transmission mode 255), to avoid overloads on the CANopen bus. The "Inhibit Time" is a multiple of 100  $\mu$ s of the value written in sub-index 3 of objects 1800H and 1805H.

The following table gives some examples of values.

Value		Inhibit Time in ms
Dec.	Hex.	
0000	0000	0
100	0064	10
1000	03E8	100
5000	1388	500
10000	2710	1000
65535	FFFF	6553.5

### Event Timer (Sub-index 5)

The Event Timer only works in asynchronous transmission mode (transmission mode 255). If data changes before the Event Timer expires, a TPDO is sent. If a value higher than 0 is written in the 16-bit field, the TPDO is sent after the Event Timer expires. The value written in sub-index 5 of objects 1800H and 1805H corresponds to the Event Timer in milliseconds. The data transfer takes place even if there is no change to data.

The following table gives some examples of values.

Value		Event Timer in ms
Dec.	Hex.	
0000	0000	0
100	0064	100
1000	03E8	1000
5000	1388	5000
10000	2710	10000
65535	FFFF	65535

---

**Object 1805H: 2nd Transmit PDO Communication Parameter**

---

**Description** This object contains the Transmit PDO identifier.

---

**Properties** The characteristics of this object are outlined in the following table:

Sub-index	Description	Data type	Default value	Access	PDO Mapping	Backed up
0	Sub-index number	UNSIGNED8	05H	ro	no	yes
1	COB-ID	UNSIGNED32	0000 0280H + Node ID	rw	no	yes
2	Transmission mode	UNSIGNED8	FFH (255 Dec	rw	no	yes
3	Inhibit Time	UNSIGNED16	0	rw	no	yes
4	Not available					
5	Event Timer	UNSIGNED16	0	rw	no	yes

---

**Transmission mode** The PDO transmission mode can be configured as described in the table below.

Transfer code		Transmission mode					Notes	
Dec.	Hex.	Cyclic	Acyclic	Synchronous	Asynchronous	RTR only		
0	0		x	x			Send PDO on first SYNC message following an event	
1 to 240	1 to F0	x		x			Send PDO every x SYNC messages	
241 to 251	F1 to FB	Reserved						-
252	FC			x		x	Receive SYNC message and send PDO on Remote Request	
253	FD				x	x	Update data and send PDO on Remote Request	
254 to 255	FE to FF				x		Send PDO on event (Change of state mode)	

**Note:** For transmission modes corresponding to transfer codes 254 and 255, the events that trigger a TPDO transmission are:

- modification of transported data status,
- the Event Timer has elapsed.

### COB-ID Structure

The structure of a COB-ID for CAN2.0 is shown in the following table:

Bit No.	Value	Meaning
31 (MSb)	0	The PDO object exists
	1	The PDO object does not exist
30	0	RTR mechanism authorized
	1	RTR mechanism not authorized
29	0	11-Bit ID (CAN 2.0A)
28 - 11	0	if bit 29 = 0
10 - 0 (LSb)	X	Bit 10 - 0 of the identifier

**Inhibit Time  
(Sub-index 3)**

In the case of PDO transmission (Transmit PDO), the Inhibit Time can be entered in this 16-bit field. After data has been changed, the PDO sender checks that an Inhibit Time has expired since the last transmission. A new PDO transmission can only take place if the Inhibit Time has expired. The Inhibit Time is useful for asynchronous transmission (transmission mode 255), to avoid overloads on the CAN bus. The Inhibit Time is a multiple of 100  $\mu$ s of the value written in sub-index 3 of objects 1800H and 1805H.

The following table gives some examples of values.

Value		Inhibit Time in ms
Dec.	Hex.	
0000	0000	0
100	0064	10
1000	03E8	100
5000	1388	500
10000	2710	1000
65535	FFFF	6553.5

**Event Timer  
(Sub-index 5)**

The Event Timer only works in asynchronous transmission mode (transmission mode 255). If data changes before the Event Timer expires, a TPDO is sent. If a value higher than 0 is written in this 16-bit field, the TPDO is sent after the Event Timer expires. The value written in sub-index 5 of objects 1800H and 1805H corresponds to the Event Timer in milliseconds. The data transfer takes place even if there is no change to data.

The following table gives some examples of values.

Value		Event Timer in ms
Dec.	Hex.	
0000	0000	0
100	0064	100
1000	03E8	1000
5000	1388	5000
10000	2710	10000
65535	FFFF	65535

## Object 1A00H: 1st Transmit PDO Mapping Parameter

**Description** This object describes the objects that will be transported by the PDO.

**Characteristics** The characteristics of this object are outlined in the following table:

Sub-index	Description	Data type	Default value	Access	PDO Mapping	Backed up
0	Sub-index number	UNSIGNED8	See table	rw	no	yes
1	1st object in the PDO	UNSIGNED32	See table	rw	no	yes
2	2nd object in the PDO	UNSIGNED32	See table	rw	no	yes
...						
8	Most recent object in PDO	UNSIGNED32	-	rw	no	yes

### Data Field Structure

Each data object to be transported is represented in the following manner:

Bits	31 to 16	15 to 8	7 to 0
Data	Index number of object to be transported	Sub-index number of object to be transported	Length of object to be transported
Example	6000H	01H	08H

**Note:**

- The maximum total length of data that can be transported by the PDO is 8 bytes.
- By default, the 1st Transmit PDO transports object 6000H.

**Default Values**

The following table gives the default value of object 1A00H depending on the splitter reference:

<b>Product references</b>	<b>Sub-index</b>	<b>Default value</b>
FTB 1CN08E08SP0	0	1
	1	6000 0108H
FTB 1CN08E08CM0 FTB 1CN12E04SP0 FTB 1CN16E•0 FTB 1CN16C•0	0	2
	1	6000 0108H
	2	6000 0208H

---



## Object 1A05H: 2nd Transmit PDO Mapping Parameter

**Description** This object describes the objects that will be transported by the PDO.

**Characteristics** The characteristics of this object are outlined in the following table:

Sub-index	Description	Data type	Default value	Access	PDO Mapping	Backed up
0	Sub-index number	UNSIGNED8	See table	rw	no	yes
1	1st object in the PDO	UNSIGNED32	See table	rw	no	yes
2	2nd object in the PDO	UNSIGNED32	See table	rw	no	yes
...						
8	Most recent object in PDO	UNSIGNED32	See table	rw	no	yes

### Data Field Structure

Each data object to be transported is represented in the following manner:

Bits	31 to 16 (MSB)	15 to 8	7 to 0 (LSB)
Data	Index number of object to be transported	Sub-index number of object to be transported	Length of object to be transported
Example	3000H	01H	08H

**Note:**

- The maximum total length of data that can be transported by the PDO is 8 bytes.
- By default, object 1A05H is configured on object 3000H (see the table below).

**Default Values**

The following table gives the default value of object 1A05H depending on the splitter reference:

<b>Product references</b>	<b>Sub-index</b>	<b>Default value</b>
FTB 1CN16E•0	0	2
	1	3000 0108H
	2	3000 0208H
FTB 1CN08E08CM0 FTB 1CN12E04SP0 FTB 1CN08E08SP0	0	4
	1	3000 0108H
	2	3000 0208H
	3	3000 0308H
	4	3000 0508H
FTB 1CN16C•0	0	6
	1	3000 0108H
	2	3000 0208H
	3	3000 0308H
	4	3000 0408H
	5	3000 0508H
	6	3000 0608H

---

---

## 8.3 Manufacturer-specific Zone Objects 2000H to 5FFFH

---

### At a Glance

---

**Introduction** This section lists the objects from the manufacturer-specific zone. Each object, with all its technical characteristics, is described according to the CANopen standard.

---

**What's in this Section?** This section contains the following topics:

Topic	Page
Object 2000H: Input / Diag Parameter	172
Object 2001H: Input/Output Parameter	173
Object 3000H: Manufacturer Specific Diagnostic	174

---

## Object 2000H: Input / Diag Parameter

---

### Description

For channels 10 to 17 (connector pin 2) this object is used to select the "input" or "diagnostics input" function.

Channels 10 to 17 are configured as "diagnostics input" by default.

The diagnostics inputs enable the use of sensors integrating a wire cut detection function.

**Note:** For configurable channels, this object's status is taken into account only if the input channel is configured by the 2001H object.

The following table shows the configuration of channels 10 to 17 according to their sub-index bit value:

Status	Description
0	Discrete input
1	Diagnostics input

### Characteristics

The characteristics of this object are outlined in the following table:

Sub-index	Description	Data type	Default value	Access	PDO Mapping	Backed up
0	Sub-index number	UNSIGNED8	1	ro	no	yes
1	Input parameter/ diagnostics input	UNSIGNED8	FFH	rw	no	yes

**Note:** Channels 10 to 17 are configured as "diagnostics inputs" by default.

---

## Object 2001H: Input/Output Parameter

**Description** This object may only be used for Advantys splitter boxes with configurable channels:

Status	Description
0	Input
1	Output

**Note:** This object takes priority over the 2000H object.

**Characteristics** The characteristics of this object are outlined in the following table:

Sub-index	Description	Data type	Default value	Access	PDO Mapping	Backed up
0	Sub-index number	UNSIGNED8	2	ro	no	yes
1	Parameter for input/output pin 4 (channels 00-07)	UNSIGNED8	0	rw	no	yes
2	Parameter for input/output pin 2 (channels 10-17)	UNSIGNED8	0	rw	no	yes

**Note:** All channels are configured as "diagnostics input" by default.

## Object 3000H: Manufacturer Specific Diagnostic

**Description** This object provides information on the status of the Advantys FTB CANopen splitter box.

**Characteristics** The characteristics of this object are outlined in the following table:

Sub-index	Description	Data type	Default value	Access	PDO Mapping	Backed up
0	Sub-index number	UNSIGNED8	7	ro	no	no
1	Common diagnostics (8 least significant MSR bits, object 1002H)	UNSIGNED8	-	ro	yes	no
2	Sensor short-circuit (0-7 connectors)	UNSIGNED8	-	ro	yes	no
3	Actuator stopped (channels 00 - 07)	UNSIGNED8	-	ro	yes	no
4	Actuator stopped (channels 10 - 17)	UNSIGNED8	-	ro	yes	no
5	Actuator overload (channels 00-07)	UNSIGNED8	-	ro	yes	no
6	Actuator overload (channels 10-17)	UNSIGNED8	-	ro	yes	no
7	Diagnostics inputs	UNSIGNED8	-	ro	yes	no

**Note:** The sub-indexes are only present in the 3000H object if the Advantys FTB splitter box offers the corresponding functions.

---

## 8.4 Hardware Profile Objects 6000H to 9FFFH

---

### At a Glance

---

#### Introduction

This section lists the objects relating to the hardware profile. Each object, with all its technical characteristics, is described according to the CANopen standard.

---

#### What's in this Section?

This section contains the following topics:

Topic	Page
Object 6000H: Read Inputs 8 Bits	176
Object 6100H: Read Input 16 Bits	177
Object 6102H: Polarity Input	178
Object 6103H: Filter Constant Input 16 Bits	179
Object 6200H: Write Outputs 8 Bits	180
Object 6300H: Write Outputs 16 Bits	181
Object 6302H: Polarity Outputs 16 Bits	182
Object 6306H: Fallback Mode 16 Bits	183
Object 6307H: Fallback Value 16 Bits	184
Object 6308H: Filter Mask Output 16 Bits	185

---

**Object 6000H: Read Inputs 8 Bits**

---

**Description** This object contains the status of discrete inputs in 8 bit format.

---

**Characteristics** The characteristics of this object are outlined in the following table:

Sub-index	Description	Data type	Default value	Access	PDO Mapping	Backed up
0	Sub-index number	UNSIGNED8	2	ro	no	no
1	Read input pin 4 (channels 00-07)	UNSIGNED8	-	ro	yes	no
2	Read input pin 2 (channels 10-17)	UNSIGNED8	-	ro	yes	no

The meaning of each bit is given in the following table:

Bit No.	Sub-index 1	Sub-index 2
0	Read input pin 4 channel 00	Read input pin 2 channel 10
1	Read input pin 4 channel 01	Read input pin 2 channel 11
2	Read input pin 4 channel 02	Read input pin 2 channel 12
3	Read input pin 4 channel 03	Read input pin 2 channel 13
4	Read input pin 4 channel 04	Read input pin 2 channel 14
5	Read input pin 4 channel 05	Read input pin 2 channel 15
6	Read input pin 4 channel 06	Read input pin 2 channel 16
7	Read input pin 4 channel 07	Read input pin 2 channel 17

---



## Object 6100H: Read Input 16 Bits

**Description** This object contains the status of discrete inputs in 16 bit format.

**Characteristics** The characteristics of this object are outlined in the following table:

Sub-index	Description	Data type	Default value	Access	PDO Mapping	Backed up
0	Sub-index number	UNSIGNED8	1	ro	no	no
1	Read input 16 bits	UNSIGNED16	-	ro	yes	no

The meaning of each bit is given in the following table:

Bit No.	Least significant meaning	Bit No.	Most significant meaning
0	Read channel 00	8	Read channel 10
1	Read channel 01	9	Read channel 11
2	Read channel 02	10	Read channel 12
3	Read channel 03	11	Read channel 13
4	Read channel 04	12	Read channel 14
5	Read channel 05	13	Read channel 15
6	Read channel 06	14	Read channel 16
7	Read channel 07	15	Read channel 17

## Object 6102H: Polarity Input

---

**Description** This object is used to define the polarity of inputs.

Value	Input type
0	not reversed
1	reversed

---

**Characteristics** The characteristics of this object are outlined in the following table:

Sub-index	Description	Data type	Default value	Access	PDO Mapping	Backed up
0	Sub-index number	UNSIGNED8	1	ro	no	yes
1	Polarity of inputs	UNSIGNED16	0	rw	no	yes

---

## Object 6103H: Filter Constant Input 16 Bits

**Description** This object is used to configure the mask for inputs.

Value	Input type
0	Input read
1	Ignored input

**Characteristics** The characteristics of this object are outlined in the following table:

Sub-index	Description	Data type	Default value	Access	PDO Mapping	Backed up
0	Sub-index number	UNSIGNED8	1	ro	no	yes
1	Filtering constant	UNSIGNED16	0	rw	no	yes

**Note:** Important notes

- By entering the value 1, no input update is implemented.
- Once the filter is enabled, the input no longer changes even if the polarity is changed.

## Object 6200H: Write Outputs 8 Bits

---

**Description** This object is used to command outputs per byte.

**Note:** The bits corresponding to a configured input channel are not used.

---

**Characteristics** The characteristics of this object are outlined in the following table:

Sub-index	Description	Data type	Default value	Access	PDO Mapping	Backed up
0	Sub-index number	UNSIGNED8	2	ro	no	yes
1	Write outputs 8 bits pin 4 (channels 00-07)	UNSIGNED8	0	rw	yes	yes
2	Write outputs 8 bits pin 2 (channels 10-17)	UNSIGNED8	0	rw	yes	yes

### **WARNING**

#### **RISK OF UNINTENDED EQUIPMENT OPERATION**

It is not advisable to use the 6200H and 6300H objects simultaneously.

Where both these objects are used, the Advantys FTB splitter box executes the most recent command received.

**Failure to follow this instruction can result in death, serious injury, or equipment damage.**

---

## Object 6300H: Write Outputs 16 Bits

**Description** This object is used to command the state of discrete outputs.

**Note:** The bits corresponding to a configured input channel are ignored.

**Characteristics** The characteristics of this object are outlined in the following table:

Sub-index	Description	Data type	Default value	Access	PDO Mapping	Backed up
0	Sub-index number	UNSIGNED8	1	ro	no	yes
1	Write outputs 16 bits	UNSIGNED16	0	rw	yes	yes

### WARNING

#### **RISK OF UNINTENDED EQUIPMENT OPERATION**

It is not advisable to use the 6200H and 6300H objects simultaneously. Where both these objects are used, the Advantys FTB splitter box executes the most recent command received.

**Failure to follow this instruction can result in death, serious injury, or equipment damage.**

**Object 6302H: Polarity Outputs 16 Bits**

---

**Description** This object is used to define the polarity of an output.

---

**Characteristics** The characteristics of this object are outlined in the following table:

Sub-index	Description	Data type	Default value	Access	PDO Mapping	Backed up
0	Sub-index number	UNSIGNED8	1	ro	no	yes
1	Output polarity	UNSIGNED16	0	rw	no	yes

---

**Polarity**

Value	Output type
0	Not reversed
1	Reversed

---

## Object 6306H:Fallback Mode 16 Bits

### Description

This object is used to define discrete output status value in the event of an error. This value is either that defined by the 6307H object, or the most recent value received before error occurrence (maintain mode).

Value	State of value
0	Maintain
1	Fallback (see object 6307H)

### Characteristics

The characteristics of this object are outlined in the following table:

Sub-index	Description	Data type	Default value	Access	PDO Mapping	Backed up
0	Sub-index number	UNSIGNED8	1	ro	no	yes
1	Fallback mode	UNSIGNED16	FFFFH	rw	no	yes

**Note:** When the value of object 6306H is FFFFH, all discrete outputs take the fallback value defined by object 6307H in the event of a fault.

**Object 6307H: Fallback Value 16 Bits**

---

**Description**

The value defined in this object is the value taken by the discrete output in the event of an error, where the bit corresponding to the 6306H object is at 1.

<b>Value</b>	<b>Output value in the event of a fault.</b>
0	Set to 0
1	Set to 1

---

**Characteristics**

The characteristics of this object are outlined in the following table:

<b>Sub-index</b>	<b>Description</b>	<b>Data type</b>	<b>Default value</b>	<b>Access</b>	<b>PDO Mapping</b>	<b>Backed up</b>
0	Sub-index number	UNSIGNED8	1	ro	no	yes
1	Fallback value	UNSIGNED16	0	rw	yes	yes

---



## Object 6308H: Filter Mask Output 16 Bits

**Description** This object is used to configure the mask for outputs.

Status	Description
0	Current output value is frozen
1	Authorizes writing output (see objects 6200H and 6300H)

**Characteristics** The characteristics of this object are outlined in the following table:

Sub-index	Description	Data type	Default value	Access	PDO Mapping	Backed up
0	Sub-index number	UNSIGNED8	1	ro	no	yes
1	Output mask filter	UNSIGNED16	FFFFH	rw	no	yes

**Note:** When the value of object 6308H is FFFFH, all discrete outputs have write authorization.



---

# Appendices



---

## At a Glance

### Introduction

This appendix provides information on common IEC symbols used in this manual.

### What's in this Appendix?

The appendix contains the following chapters:

Chapter	Chapter Name	Page
A	IEC Symbols	189



---

# IEC Symbols



---

## Glossary of Symbols







### Introduction

This section contains illustrations and definitions of common IEC symbols used in describing wiring schematics.

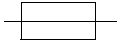
---

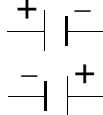
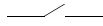
**Symbols**

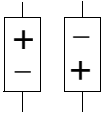
Common IEC symbols are illustrated and defined in the table below:

	Fuse
	Load
	AC power
	DC power
	Digital sensor/input, for example, contact, switch, initiator, light barrier, and so on.
	Earth ground
	2-wire sensor
	Thermocouple element

---

# Glossary

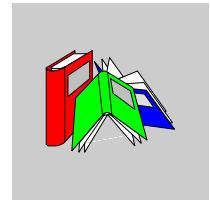

---

## C

<b>CAL</b>	CAN Application Layer. 'Application' Layer (ISO/OSI layer 7 for systems interconnection model) defined by CAN in Automation (CiA).
<b>CAN</b>	Controller Area Network.
<b>CE</b>	European Community
<b>CiA</b>	CAN in Automation (declared association); CAN bus manufacturers and users organization.
<b>CiA Draft Standard 102</b>	Description of the CAN physical communication (layer 2) for industrial applications.
<b>CiA Draft Standard 301</b>	Description of the CAN physical communication (layer 2) for industrial applications.
<b>CiA Draft Standard 302</b>	Description of the communication profile for industrial systems.
<b>CiA Draft Standard 401</b>	Description of the CAN physical communication (layer 2) for industrial applications.
<b>CMS</b>	CAN Message Specification. 'Application' layer service for object usage and management.
<b>COB</b>	Communication Object. Messages are sent in COBs in a network, and are considered as communication objects.

<b>COB-ID</b>	COB-Identifier. Each communication object is clearly identified by the COB-ID identifier, which determines the object's priority.
<b>CSMA/CA</b>	Carrier Sense Multiple Access / Collision Avoidance (Multiple access using carrier sensing with collision notification).

---

**D**

<b>DBT</b>	COB-ID Distributor. 'Application' layer service, used to assign COB-ID identifiers to communication objects in CMS services.
<b>DESINA</b>	Standard relating to the connector technology of sensors and actuators, established by a German association of machine manufacturers.
<b>DI</b>	Digital Input (discrete input)
<b>DIN</b>	German standards institute
<b>DO</b>	Digital Output (discrete output)

---

**E**

<b>EDS</b>	An Electronic Data Sheet is a file in standard ASCII format containing information on a communication functionality of a network device and the content of its object dictionary. The EDS also defines device-specific and manufacturer-specific objects.
<b>EN</b>	European standard

---

**F**

<b>FTB</b>	Advantys IP67 monobloc input/output splitter box.
------------	---

---



**I**

- IEC** International Electrotechnical Commission.
- Island** On the Advantys Configuration Tool interface, the Advantys IP67 monobloc input/output splitter box is referred to as "island".
- ISO** International Standard Organization
- 

**L**

- LED** Light Emitting Diode
- LMT** Layer Management. Parameter definition concerning different layers for a bus head.
- LSB** Least Significant Byte. The part of a number, address or field that is written as the value furthest to the right in conventional hexadecimal or binary notation.
- LSb** Least Significant Bit. The part of a number, address or field that is written as the value furthest to the right in conventional hexadecimal or binary notation.
- 

**M**

- MNS** Module-Network-Status
- MSB** Most Significant Byte. The part of a number, address or field that is written as the value furthest to the left in conventional hexadecimal or binary notation.
- MSb** Most Significant Bit. The part of a number, address or field that is written as the value furthest to the left in conventional hexadecimal or binary notation.
-

**N**

**NMT** Network Management Telegram. NMT protocols offer services for network initialization, error checking and checking device states.

---

**O**

**OSI** Open Systems Interconnection

---

**P**

**PDO** Process Data Object. On networks based on CAN technology, PDOs (Process Data Objects) are transmitted as broadcast messages without confirmation or sent from a producer device to a consumer device.

**PLC** Programmable Logic Controller

---

**R**

**ro** Read-only.

**rw** Read-write

---

**S**

**SDO** Service Data Object. On networks based on CAN technology, the field bus master uses SDO (Service Data Object) messages for access (read/write) to the network node object dictionaries.

**Splitter box** Advantys IP67 monobloc input/output splitter box.

---

<b>String</b>	ASCII character string
<b>SYNC</b>	Synchronization object

---



---

# Index

---

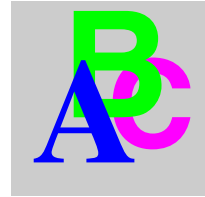

## B

Boot-Up, 53

## C

CAN bus line, 49

CAN-H, 49

CAN-L, 49

CANopen

    Description, 49

    The Protocol, 49

Characteristics

    Inputs, 29

    outputs, 29

    Splitter box, 29

## E

EDS

    EDS File, 102

    Existing EDS File, 103

EMC Compatibility, 23

Environment

    environment, 28

Error Codes, 128

## F

Field Bus Status Diagnostics, 125

FTB, 12

## G

Ground Electrode

    Connection, 21

    Position, 21, 22

Guard Time, 144

## H

Heartbeat Time, 65

## I

I/O Status Diagnostics, 126

IEC symbols, 189

Installation, 17

Introduction to Wiring, 38

## L

Life Guarding, 62

Life Time Factor, 145

Life-Time, 62

## M

M12 Connectors

    Assignment of Pins for a Field Bus, 44

    Pin Assignment for Actuators and

    Sensors, 30

Mini-Style 7/8" Connector, 32

**Mode**

- Operational, 55
- Pre-Operational, 55

**N**

- Node Guarding, 62
- Node-ID
  - Configuration, 46

**O**

- Object Dictionary, 133
  - index ranges, 133
- Overview, 16

**P**

- PDO Object
  - mapping, 133
- Physical layer, 49
  - CAN bus line, 49
- Properties, 28

**S**

- Software Diagnostics, 127
- SUB-D Connectors
  - Assignment of Pins, 45
- Symbols, 189

**T**

- Tap-off, 40
- The Device Profile, 52
- Transmission Speed
  - Configuration, 46

**U**

- Unit
  - Dimensions, 18, 19

## Free Manuals Download Website

<http://myh66.com>

<http://usermanuals.us>

<http://www.somanuals.com>

<http://www.4manuals.cc>

<http://www.manual-lib.com>

<http://www.404manual.com>

<http://www.luxmanual.com>

<http://aubethermostatmanual.com>

Golf course search by state

<http://golfingnear.com>

Email search by domain

<http://emailbydomain.com>

Auto manuals search

<http://auto.somanuals.com>

TV manuals search

<http://tv.somanuals.com>