

# WORKING WITH

evolution wireless G3



COMPREHENSIVE GUIDE  
TO SETTING UP, CONFIGURING AND USING  
EVOLUTION WIRELESS G3 SYSTEMS

 **SENNHEISER**

**APPLICABLE FOR USE IN THE U.S.  
CONSUMER ALERT**

Most users do not need a license to operate a wireless microphone system. Nevertheless, operating a microphone system without a license is subject to certain restrictions: the system may not cause harmful interference; it must operate at a low power level (not in excess of 50 milliwatts); and it has no protection from interference received from any other device. Purchasers should also be aware that the FCC is currently evaluating use of wireless microphone systems, and these rules are subject to change. For more information, call the FCC at 1-888-CALL-FCC (TTY: 1-888-TELL-FCC) or visit the FCC's wireless microphone website at: [www.fcc.gov/cgb/wirelessmicrophones](http://www.fcc.gov/cgb/wirelessmicrophones)

## Table of Contents

Introduction .....	4
The Building Blocks of a Wireless System .....	5
The Transmitter .....	6
The Receiver .....	7
Antennas .....	8
Wireless Monitoring Systems .....	9
Choosing a Wireless System.....	10
Selecting Systems and Components .....	11
Accessorizing a Wireless System .....	11
Operation: Frequency Considerations .....	12
Putting Together a System.....	13
Four Channel Wireless System.....	13
Eight Channel Wireless System .....	14
Single Channel Wireless Monitor System .....	15
Four Channel Wireless Monitor System.....	15
Antenna Distribution and Mounting Packages.....	16
Frequently Asked Questions .....	17
Conclusion.....	19
Appendix: Frequency Preset Charts.....	19

Visit Sennheiser's YouTube channel at:  
**[www.youtube.com/sennheiserUSA](http://www.youtube.com/sennheiserUSA)**  
to watch several video clips that will help  
you set up and operate the evolution  
wireless G3 systems

## Welcome to evolution wireless G3

Wireless microphone and monitoring systems have become standard equipment for musicians, broadcasters, theatre productions, television shows, and sound contractors alike. Sennheiser has been the industry leader in wireless systems for over 50 years, and is proud to bring its Emmy Award-winning advances in RF (radio frequency) to evolution wireless G3.

Sennheiser's evolution wireless G3 systems elegantly solve two classic challenges: avoiding interference and building complex, multi-channel systems. Sennheiser evolution wireless G3 offers 1,680 tunable UHF frequencies across 42 MHz and an easy-to-use "Easy Setup" function that scans for interference and recommends "free" frequencies that will yield the most reliable operation. For setting up multi-channel systems, evolution wireless G3 includes 20 banks of coordinated frequencies, each set calculated to work together without interference – an undesirable effect called intermodulation. With evolution wireless G3, building a reliable, interference-free multi-channel setup has never been easier!

From small clubs to boardrooms to Broadway stages or stadium-sized concert halls, Sennheiser evolution wireless G3 is used with confidence every day by professional users the world over.

### About UHF Wireless

Sennheiser wireless systems operate in the UHF (Ultra High Frequency) range. UHF is the most common, most reliable format for wireless systems today. Within the US, wireless systems are allowed to operate from 470 – 698 MHz. Within this available spectrum, Sennheiser evolution wireless G3 systems are available in three frequency ranges: A (516-558 MHz), G (566-608 MHz), B (626-668 MHz)

# The Building Blocks of a Wireless System

Every wireless system consists of three main components:

## 1) Transmitter

The transmitter accepts a (mic or line) input signal, converts it into an RF (radio frequency) signal, and then transmits it.



G3 SKM Handheld Transmitter



G3 SKP Plug-On Transmitter



G3 SK Bodypack Transmitter

## 2) Receiver

The receiver picks up the transmitted RF signal, converts it back into an audio signal, and then outputs it for mixing and amplification.



G3 EM Rack-Mount Receiver



G3 EK Camera-Mount Receiver

## 3) Antennas

Antennas handle the sending and receiving of the RF signal between the two components. Antennas may be either active or passive, depending on the system configuration.

A1031-U  
Passive Omnidirectional  
UHF Antenna



A2003-UHF  
Passive Directional  
UHF Antenna



## The Transmitter

The transmitter has a fairly straightforward job: take a microphone or line-level input signal, convert it into an RF signal, and transmit it. It sounds easy, but there are a number of variables involved in producing accurate and dependable transmissions.

Professional events demand reliability and extensive operating range, regardless of conditions. Sennheiser's evolution wireless G3 transmitters meet that challenge with 30 mW of output power, which can deliver approximately 300 feet of operating range (line of sight) in a good RF environment. With rugged metal housings, G3 series transmitters are built to endure wear-and-tear, for consistent results, night after night.

To preserve every nuance of your performance, evolution wireless G3 employs a proprietary noise-reduction system called HDX™, which maximizes audio quality and avoids the noise inherent in most RF systems. HDX™ converts the analog audio signal to RF and back to analog again, all with stunning accuracy and quality. With a wide frequency response of 25 Hz to 18 kHz (line), evolution wireless G3 sounds as good as our wired microphones.

There are three basic types of wireless transmitters:

### 1) Handheld transmitters

Handhelds are the most recognizable form of transmitter, most closely resembling traditional wired microphones. All evolution wireless G3 handheld transmitters (SKM 100 G3, SKM 300 G3, and SKM 500 G3) are designed to offer exceptional sound, with user-swappable dynamic and condenser capsules from our evolution 800 (e835, e845, e865) and 900 (e935, e945, e965) series wired microphones.



G3 Handheld Transmitter

### 2) Bodypack transmitters

Sennheiser evolution wireless G3 bodypack transmitters (SK 100 G3, SK 300 G3, and SK 500 G3) offer adjustable input sensitivity control to complement a wide range of lavalier microphones (ME2 omni, ME4 cardioid, MKE 2 Gold omni), headmics (ME3-ew, HSP4-ew, Ear Set 4-ew), or line-level signals such as electric guitars and basses. With compact, rugged designs, bodypack transmitters are commonly used in musicals, theatrical stages, film and television sets.



ME3 Headset Mic



ME2 and 4 Lavalier Mics



G3 Bodypack Transmitter

### 3) Plug-on transmitters

Plug-on transmitters are often used on location news-casts, reality TV, and movie sets to convert traditional wired microphones or line level signals into wireless devices. The SKP 100 G3 plug-on is ideal suited for dynamic mics, such as the MD 42 or MD 46. For condenser mics requiring 48v phantom power, such as the MKH 416 shotgun microphone, Sennheiser also offers the phantom power-equipped SKP 300 G3.



G3 Plug-On Transmitter

Sennheiser's G3 portable transmitters can operate for up to 8 hours on a pair of AA batteries. Audio and RF transmission quality is never compromised as batteries run down, thanks to dedicated circuitry that maintains a constant internal system voltage. G3 transmitters also relay battery strength to their receivers, allowing sound engineers to remotely monitor battery life at a glance. G3 handheld and bodypack transmitters also feature external charging contacts, for use with optional BA 2015 rechargeable battery packs and the L 2015 charging station.

## The Receiver

The heart of every wireless system, the receiver is designed to pick up an RF signal sent from the transmitter, convert it back into an audio signal, and output it for mixing, recording, and amplification.

There are two basic types of wireless receivers:

### 1) Fixed (rack-mount) receivers

The most common version, G3 series fixed receivers (EM 100 G3, EM 300 G3, and EM 500 G3) are compact, half-rack sized units which can be mounted in standard 19" equipment racks using the optional GA3 rack-mount adapter. Sennheiser employs True Diversity antenna technology in its G3 rack-mount receivers, to ensure the most stable, uninterrupted wireless reception. True Diversity receivers contain two independent tuning modules and a comparison circuit that continuously routes the stronger signal to the receiver's output. Put simply, True Diversity maximizes system reliability.



G3 Rack-mountable Receiver



G3 Portable Receiver

### 2) Portable (camera-mount) receivers

Portable receivers are used in film, television, and video applications to wirelessly feed audio into a video camera or other portable recording device. The EK 100 G3 portable camera-mount receiver is compact, lightweight, battery-powered, and can mount directly onto a wide variety of motion-picture or video cameras which have a standard shoe mount. Adaptive Diversity antenna technology is featured on evolution wireless G3 portable receivers to increase stability. In Adaptive Diversity, the receiver utilizes the output cable as a secondary antenna, enhancing reception and reducing dropouts.

## Antennas

For basic wireless applications, the supplied antenna rods provide excellent results. For more complicated systems, remote antennas can further enhance reliability and reception.

There are two common remote antennas used for multi-channel systems:

### 1) Omnidirectional Antennas

Omnidirectional antennas, such as the passive A1031-U, receive or radiate UHF signals in a circular, 'donut' shaped pattern. Omnidirectional antennas are an excellent choice for indoor applications and situations where the transmitter's range of movement is unpredictable.



A1031-U

### 2) Directional Antennas

Directional antennas, such as the passive A2003-UHF, provide superior passive forward gain and 'reach' by suppressing unwanted RF signals from behind. Directional antennas excel in outdoor applications and situations where the transmitter's range of movement is contained to a specific area, such as a stage.



A2003-UHF

Remote antennas often enhance system performance through better placement. Stand-mountable remote antennas can be located physically higher than antenna rods, which improves line of sight and reduces disruptive reflections. Wider antenna spacing is also possible, which enhances stability by maximizing diversity. In multi-channel setups, receivers are often rack-mounted, which can place numerous metal housings in the transmission path. By relocating the antennas out of the rack, signal quality can also be significantly enhanced.

In multi-channel applications, the signal from a master pair of remote antennas can be distributed to multiple receivers simultaneously by an antenna splitter.

### Active Antenna Distribution

The ASA 1 is an active, dual 1:4 splitter, capable of feeding up to four diversity receivers from a pair of master antennas. Two ASA 1s can be coupled together to feed up to eight receivers. The ASA 1 maintains unity gain by first boosting the incoming signal before passively splitting it to multiple outputs. In addition to antenna distribution, the ASA 1 also provides DC power distribution for all connected G3 series receivers, streamlining wiring by eliminating numerous individual power supplies.



ASA 1 Active Antenna Splitter



## Wireless Monitoring Systems

Wireless monitor systems are quietly revolutionizing live sound. In-ear monitor receivers allow musicians to hear themselves and other instruments while performing, without the need for loud monitor wedges. Monitor systems not only reduce stage volume and the risk of feedback, they also provide freedom of movement and excellent hearing protection due to reduced listening levels.

Similar to the wireless microphone systems discussed earlier, wireless monitoring systems utilize very similar building blocks:

### (Rack-mount) Transmitter:

The SR 300IEM G3 transmitter can send either a mono or stereo-multiplexed signal via a pair of balanced 1/4" / XLR combination jacks. With 1,680 available UHF frequencies and easy multi-channel operation, the system can provide wireless monitoring for every performer on stage. Robust output power (30 mW) provides extended range and signal stability.



SR 300IEM G3 Transmitter

### (Portable) Receiver:

The compact EK 300IEM G3 bodypack receiver provides the performer with clear, interference-resistant monitoring. A unique "Stereo / Focus" mode toggles between standard stereo monitoring and Focus (mono) mode. In Focus mode, users can freely adjust the balance of the system's two channels to create a custom monitor mix (for example, to create a balance between vocals with instrumentation). A large, easy-to-use knob allows users to control volume, while an adjustable Audio Limiter can be engaged to protect against hearing loss. Multiple receivers can receive and listen to the same signal, allowing performers to share a monitor mix.



EK 300 IEM + IE 4

The ew 300IEM G3 monitor system includes Sennheiser's high quality IE4 stereo earphones, which provide lightweight, comfortable listening. The receiver can also be used with custom ear molds (ordered separately) for the ultimate in wireless comfort, fit and performance. The EK 300IEM G3 receiver utilizes Adaptive Diversity, which uses the IE4's output cable as a secondary antenna, increasing system stability.

### Antennas / Antenna Combiners:

Monitor systems use a single transmit antenna to send their signal to the receiver. The A2003-UHF passive directional antenna is an excellent choice for a remote IEM transmit antenna, particularly in situations where the performers are in a set location, such as a stage.



AC3

For larger systems, Sennheiser offers the AC3 antenna combiner, which can combine up to four transmission signals onto a single transmit antenna, greatly reducing the possibility of intermodulation.

## Choosing a Wireless System

Sennheiser's evolution wireless G3 line is available in three performance grades – ew 100 G3, ew 300 G3, and ew 500 G3. All three lines are fully compatible, sharing identical RF technology with 1,680 tunable frequencies, 30 mW of output power and True Diversity reception on all rackmount receivers. Every component features Sennheiser's proprietary HDX™ compander circuitry for crystal-clear audio, and an innovative infrared sync that allows the receiver to quickly program the transmitter to a new frequency. With the press of the SYNC button, the receiver transfers the desired frequency into the transmitter, greatly simplifying the setup process.

Looking beyond the shared core RF platform, each series offers unique features that address increasingly complex multi-channel applications. The ew 100 G3 series offers streamlined, portable wireless solutions. The ew 300 G3 series enhances control with integrated mute functions and remote control over Ethernet. The ew 500 G3 series delivers with Sennheiser's top-of-the-line mic capsules and lavalier elements, for the best possible audio quality.

	EW 100 G3	EW 300 G3	EW 500 G3
Switching bandwidth	42 MHz		
Tunable frequencies	1,680		
Synchronization	Infrared		
Noise Reduction	HDX		
RF output power	30 mW	selectable 10 / 30 mW	
Frequency Banks	20 Preset (intermod free) 1 User Programmable	20 Preset (intermod free) 6 User Programmable	
Channels per Bank	12	24	32
Mic capsules (handheld)	e 800 series		e 900 series
Mic elements (lavalier)	ME 2 / ME 4		MKE 2 Gold
Audio Control (handheld)	-	Mute button on body	-
Audio Control (bodypack)	-	Optional RMS 1	-
Receiver Display	Small / 1 color	Large / 2-color	
Networkable (remote monitoring, media control)	-	Ethernet / RJ45	
Squelch	Adjustable in 3 levels (low/medium/high)	Adjustable in 2dB steps	

One of the most important considerations in selecting the right wireless series for an application is the number of channels required. G3 systems offer 20 "Banks" of coordinated frequency presets, known as "Channels." For reliable operation, all systems in a given frequency range should be set to the same Bank, each to a unique available Channel. The number of Channels per Bank increases with the series, up to 32 per bank in ew 500 G3. Larger multi-channel systems will be easier to set up and coordinate with the more advanced series, like ew 500 G3.

One of the more powerful features found in ew 300 and ew 500 G3 systems is an Ethernet RJ 45 port, which allows users to remotely program and monitor their systems using Sennheiser's Wireless Systems Manager software, on either a Mac or PC. When interconnected with an Ethernet switch, ew 300 and 500 series systems can also perform a networked Easy Setup, distributing the results of a common scan to all connected receivers - resulting in faster setup and coordination.

## Selecting Systems and Components

Sennheiser offers a wide range of evolution wireless G3 systems to cover almost any wireless application, from wireless instruments to personal monitoring to portable ENG systems. G3 systems are sold in sets, containing a matched transmitter and receiver, including:

	EW 100 G3	EW 300 G3	EW 500 G3
Handheld Systems	ew 135 G3 ew 145 G3 ew 165 G3	ew 335 G3 ew 345 G3 ew 365 G3	ew 500-935 G3 ew 500-945 G3 ew 500-965 G3
Lavalier Systems	ew 112 G3 ew 122 G3	ew 312 G3 ew 322 G3	ew 512 G3
Headmic Systems	ew 152 G3	ew 352 G3	-
Instrument Systems	ew 172 G3	-	ew 572 G3
Portable / Camera Systems	ew 112P G3 ew 122P G3 ew 135P G3 ew 100 ENG G3	-	-
Monitoring Systems	-	ew 300 IEM G3 ew 300 2-IEM G3	-

Additional components can be added to enhance any system, but it is important to identify and select the matching frequency range to ensure compatibility. To help simplify the matching process, Sennheiser clearly prints the tuning range (A, G or B) on the back of all components. Transmitters and receivers must also use the same compander circuitry to provide correct audio results. Sennheiser's proprietary HDX™ circuitry is featured in all three generations of evolution wireless (G1 / G2 / G3), as well as our 2000 Series. As long as the frequency range matches, evolution wireless and 2000 Series are fully forward and backwards compatible.

## Accessorizing a Wireless System

Sennheiser offers many useful accessories for evolution wireless G3 to help expand the functionality of the system. A few common accessories include:

### GA3 Rack Adapter

For convenient side-by-side mounting of up to two fixed EM receivers, SR transmitters, ASA1 splitters or AC3 combiners in a standard 19" rack. Included with ew 300 G3 and ew 500 G3 systems, available separately for ew 100 G3 systems.



GA3

### AM2 Front Mount Antenna Kit

For use with a rack-mounted G3 receiver, transmitter, splitter or combiner, the AM2 extends a pair of antenna rods to the half-rack front panel included in the GA3 rack-mounting kit. Front-mounting antenna rods can enhance system performance, when compared to antennas "buried" inside the rack.



AM2

### RMS 1 Remote Mute Switch

For use exclusively with the SK 300 G3, the RMS 1 is a programmable remote mute switch which performs specialty applications such as press-to-talk or press-to-mute.



RMS 1

## Operation: Frequency Considerations

The successful operation of an RF wireless system greatly depends on two things:

- 1) The frequencies used must avoid interference from competing signals, such as television broadcast.
- 2) The frequencies used must not interfere with each other. Selected frequencies need to be carefully calculated for sufficient spacing, and to avoid creating disruptive interference known as intermodulation.

Geographic location plays a major role in the performance of your wireless system. The primary source of competition is television broadcast transmission towers. It is likely that one or more television stations will be broadcasting within range of your wireless system, creating sources of interference. In planning your systems' frequency requirements, it is advisable to determine what frequencies are in use by local television stations. Sennheiser's website, [www.sennheiserUSA.com](http://www.sennheiserUSA.com), has an interactive Frequency Finder which can assist in identifying the local TV stations broadcasting in your area.

Local television stations are not the only source of interference, so having a complete knowledge of your RF environment is an important step in planning your wireless microphone system.

To provide users with additional flexibility to avoid interference, evolution wireless G3 systems are available in three distinct frequency ranges (A, G, B). Each range contains 1,680 user-selectable frequencies and 20 "Banks" of coordinated frequency presets, known as "Channels." For proper multi-channel setup, all units in a frequency range should be set to the same Bank, each to a different available Channel.

All G3 systems include an easy-to-use EASY SETUP process, which ensures your units are set to fully compatible frequencies that avoid local interference.

### Easy Setup / Scan New List:

1. On the receiver, press SET to enter menu. Press up/down buttons to select "Easy Setup". Press SET and choose "Scan New List." Press SET to start scan.
2. After the scan is complete, the receiver will recommend the "Bank" with the most "Channels" free. Press SET. Select a Channel using the up/down arrows and press SET to confirm. The receiver will say "STORED."
3. Tap the POWER button to exit the menu. The new selected frequency will be displayed. You should see little to no RF activity on the meter (meaning, you are on a free channel).
4. Power up the transmitter you wish to pair with the receiver. Locate the transmitter's infrared (IR) port. On a G3 handheld transmitter, the port is located on the LCD display. On a bodypack transmitter, it is located inside the battery compartment, to the right of the ON/OFF button.
5. For a rack-mount (EM) receiver, press the "SYNC" button on the front of the receiver. On a portable (EK) receiver, press SET and use the up/down button to find "Sync." Press SET. Hold the transmitter's IR port in front of the receiver's IR port, which is located on the left side of the display. Be sure to align the IR ports so they face each other, approximately 1" to 2" apart.
6. If the SYNC is successful, you will see a "✓" on the receiver screen. If you see an "X", SYNC failed and you should repeat step 5.
7. After a successful SYNC, you should see the same frequency displayed on both the receiver and transmitter.
8. If setting up another system in the same frequency range (A/B/G), you can repeat the process from Step 1. Make sure to choose the same BANK number as you did in step 2 to ensure compatible operation, and a different channel number.

## Putting Together a System

Following are diagrams of several typical wireless microphone and wireless monitor systems.

**NOTE:** For systems larger than 8 channels, we recommend using Sennheiser's 2000 Series wireless: [www.sennheiserUSA.com/2000Series](http://www.sennheiserUSA.com/2000Series)

### Four Channel Wireless System

(4 Handheld Systems)

Qty	Model	Description
4	ew 335 G3	Handheld Systems w/MMD 835-1 capsules
1	G3 Front Kit 4	Active splitter kit for four receiver system using front-mount antennas, includes ASA1/NT, GA3, AM2

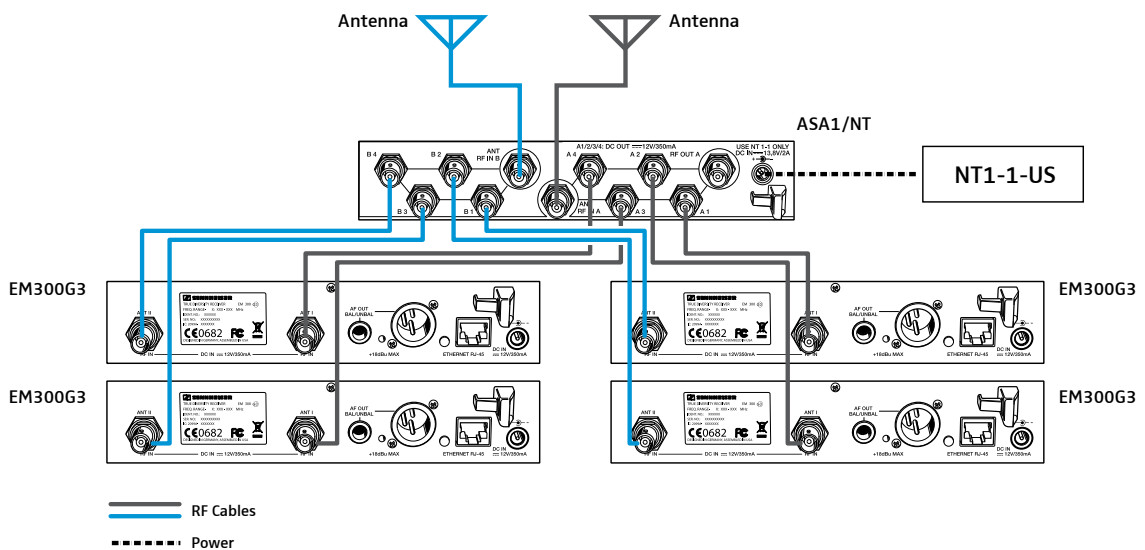
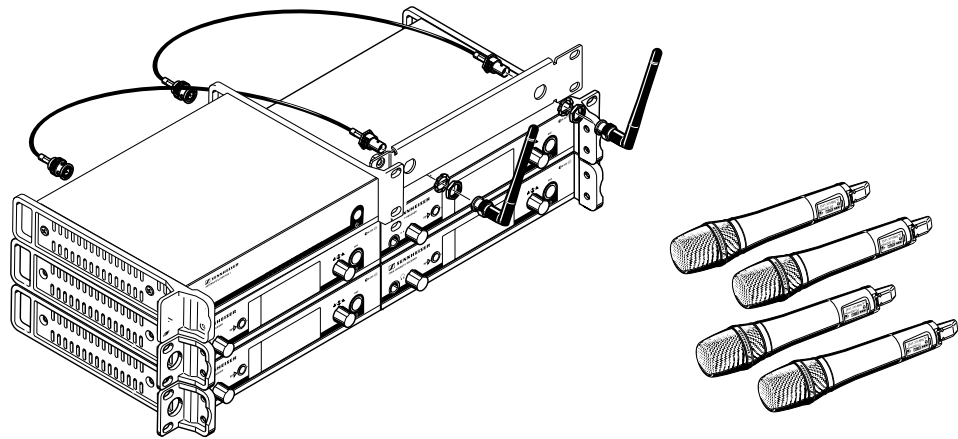

**PRO TIP:** DC Power for (EM) receivers is provided via the "A" Outputs

# Eight Channel Wireless System

(4 Handheld Systems and 4 Lavalier Systems)

Qty	Model	Description
4	ew 365 G3	Handheld Systems w/MME865-1 capsules
4	ew 312 G3	Lavalier Systems w/ME2 capsules
1	G3 Omni Kit 8	Active splitter kit for eight receiver system using omnidirectional remote paddle antennas, includes two (2) ASA1/NT, two (2) A1031-U, GA3, two (2) BB1

Note: Various Lengths of RF cable available for antenna run (sold separately)

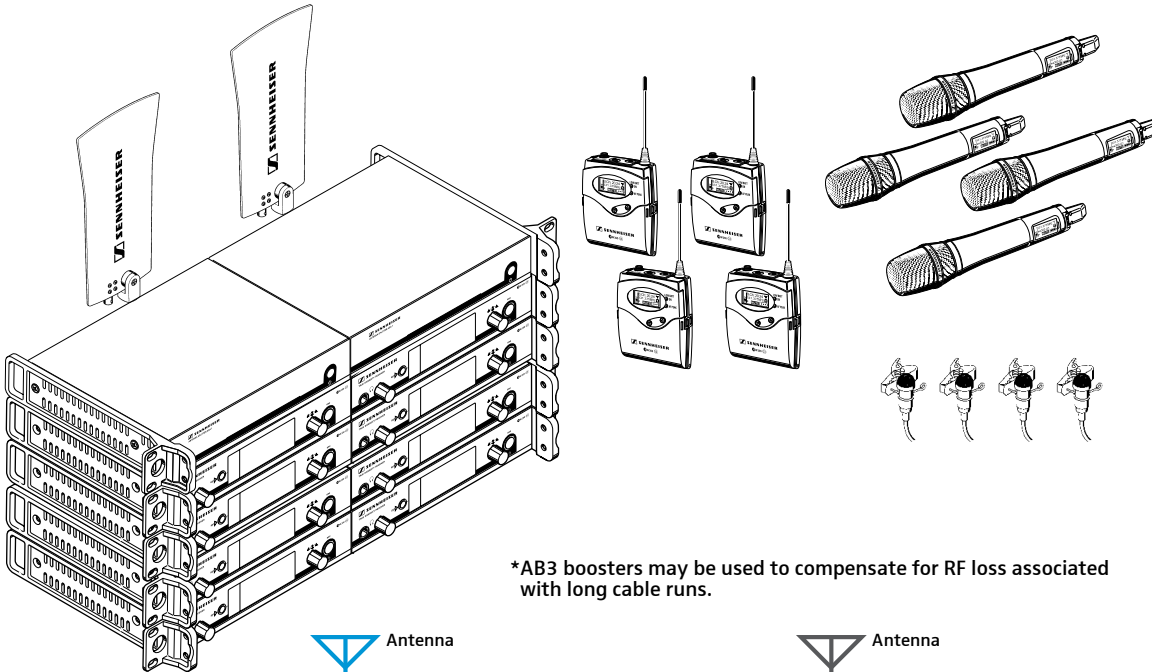

\*AB3 boosters may be used to compensate for RF loss associated with long cable runs.

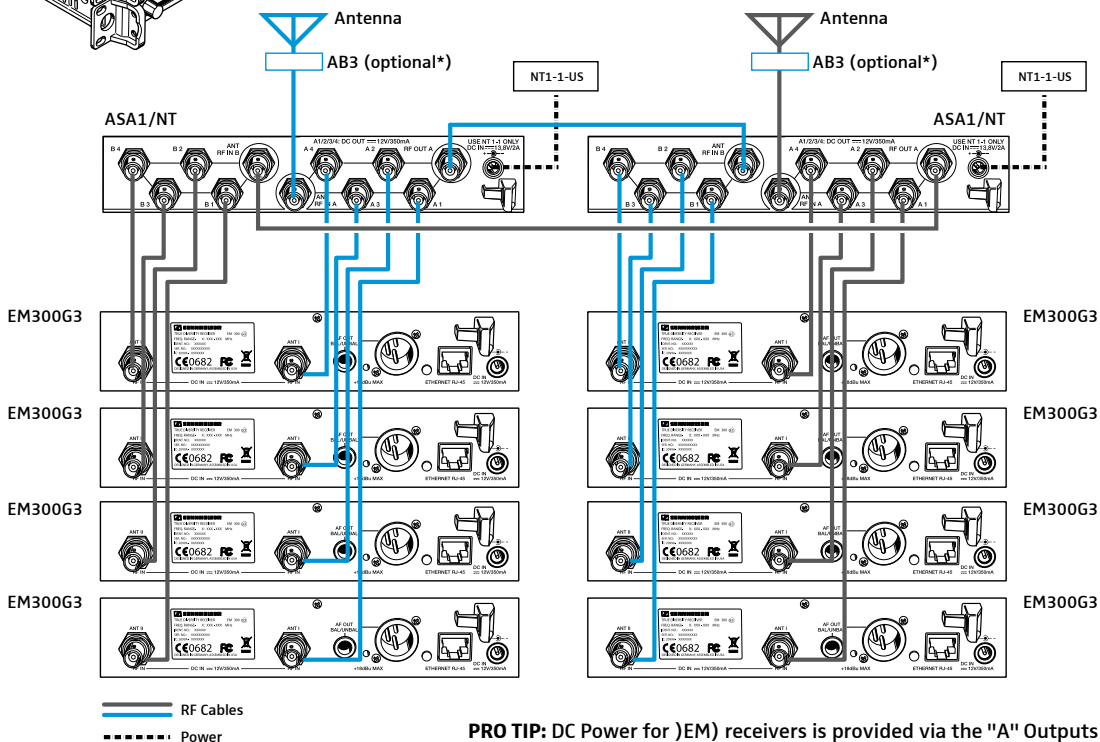

## Single Channel Wireless Monitor System

(1 ew 300IEM G3 system, for a single stage mix)

*NOTE: additional EK300 receivers may be added as needed to monitor the same mix*

Qty	Model	Description
1	ew 300IEM G3	Wireless monitor system with rack mountable transmitter, GA3 rack mount kit, bodypack receiver and IE4 earbuds

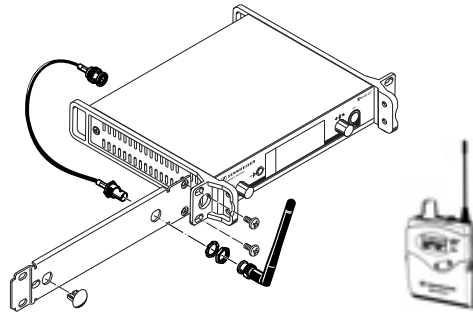

## Four Channel Wireless Monitor System

(4 ew300IEMG3 systems)

Qty	Model	Description
4	ew 300IEM G3	Wireless monitor system with rack mountable transmitter, GA3 rack mount kit, bodypack receiver and IE4 earbuds
1	G3 IEM Dir Kit 4	Active combiner kit for four IEM transmitters with DC power distribution, includes AC3/NT, GA3, A2003-UHF

**Note:** Various Lengths of RF cable available for antenna run (sold separately)

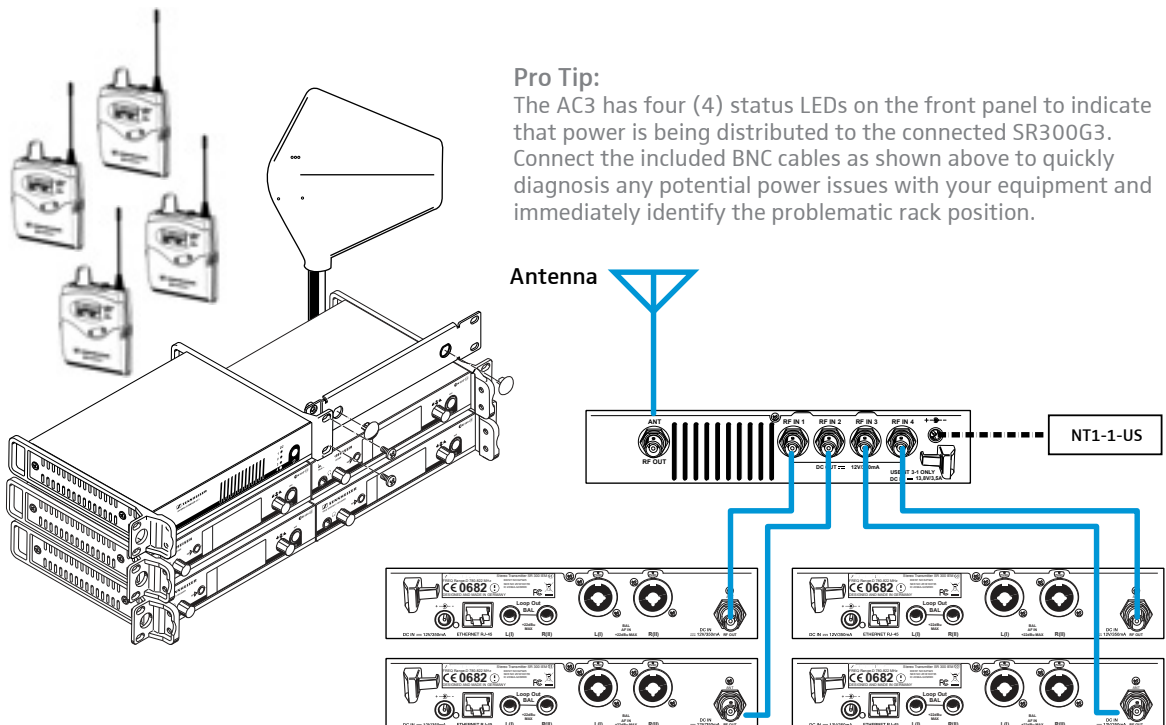

## Antenna Distribution and Mounting Packages

Sennheiser has put together several antennas distribution packages to address common wireless scenarios.

### **G3 OMNI KIT 4**

Active splitter kit for four receiver system using omnidirectional remote paddle antennas, includes:

- (1) ASA1/NT active splitter
- (2) A1031-U antennas
- (1) GA3 rack mount kit

### **G3 OMNI KIT 8**

Active splitter kit for eight receiver system using omnidirectional remote paddle antennas, includes:

- (2) ASA1/NT active splitters
- (2) A1031-U antennas
- (1) GA3 rack mount kit
- (2) BB1 interconnect BNC cables

### **G3 DIR KIT 4**

Active splitter kit for four receiver system using directional remote paddle antennas, includes:

- (1) ASA1/NT active splitter
- (2) A2003-UHF antennas
- (1) GA3 rack mount kit

### **G3 DIR KIT 8**

Active splitter kit for eight receiver system using directional remote paddle antennas, includes:

- (2) ASA1/NT active splitters
- (2) A2003-UHF antennas
- (1) GA3 rack mount kit
- (2) BB1 interconnect BNC cables

### **G3 IEM DIR KIT 4**

Active combiner kit for four IEM transmitters with DC power distribution, includes:

- (1) AC3/NT active combiner
- (1) A2003-UHF antennas
- (1) GA3 rack mount kit

### **G3 FRONT KIT 4**

Active splitter kit for four receiver system using front-mount antennas, includes:

- (1) ASA1/NT active splitter
- (1) AM2 front mount kit
- (1) GA3 rack mount kit

### **G3 FRONT KIT 8**

Active splitter kit for eight receiver system using front-mount antennas, includes:

- (2) ASA1/NT active splitters
- (1) AM2 front mount kit
- (1) GA3 rack mount kit
- (2) BB1 BNC interconnect cables

**NOTE:** The antennas supplied with all ew rack-mountable receivers are to be used only in chassis-mounted (rear jacks), or in conjunction with the AM2 front-mounting kit. These are ground plane devices and are never to be used as a remote antenna solution on the end of a cable.

The following items are not included with Sennheiser's antenna distribution kits.

You may require any of the following:

- Low loss antenna cable to connect remote antennas to the antenna distribution (cable length to suit the application)
- Mounting brackets for remote antennas
- Rack screws
- Additional GA3 rack-mount kits (not included with ew 100 G3 series systems)



## Frequently Asked Questions

### *Why does my receiver emit a horrible loud static noise when I power off my transmitter?*

This simply means your wireless system is operating on a frequency that is already in use, most likely by a television station. When the transmitter is on, everything may work fine because the transmitter's proximity overpowers the television signal. When the transmitter is powered off, the receiver still attempts to latch onto any signal it can find. If you see RF activity on the receiver's meters while the transmitter is powered off, that means that there is another signal interfering with your system (most likely TV). You can use the "Easy Setup" / "Scan New List" process to find a new free frequency. Once you identify and select a free frequency, this loud static noise will no longer come through your system when the transmitter is powered off. If you use your system in various locations, it is always a good idea to perform the "Easy Setup" process to identify a clean frequency as the RF environment will change with geographic location. If your receiver cannot find a free Channel on which to operate, a temporary solution is to raise "Squelch" from "Low" to the "Med" setting. Raising Squelch will block larger RF signals. This is a temporary solution, and should only be used as a last resort as raising Squelch also reduces operating range. It is always best to find a free frequency, whenever possible.

### *My wireless system is on and functioning, however I am experiencing feedback and poor sound quality through my PA system.*

From the factory, the output level on G3 rack-mount receivers is set to +18dB. This is a very strong signal and can result in feedback or poor sound quality with certain mixing consoles and amps. To remedy this, you can adjust the "AF OUT" menu on the receiver to a lower number. It is recommended to start at around "0 dB" and perhaps "+3 dB or +6 dB" depending on your application. These are guidelines, so feel free to experiment to get the best sound possible from your particular system.

### *Can I use rechargeable batteries?*

Yes. Sennheiser offers the BA2015 rechargeable battery pack and the L2015/NT charging station. Most G3 portable components feature external charging contacts to allow charging the BA2015 by simply placing the portable device into the L2015 charger. Standard "AA" rechargeable batteries can be used with G3 systems, however the external contacts will only serve to charge the BA2015. The battery meter may also indicate a low battery status more quickly, due to the lower voltage produced by NiMH rechargeable batteries. The BA2015 was designed to provide the correct battery reading, and is the recommended solution.

### *AF and RF Mute – what's the difference?*

With G3 bodypack transmitters, users can program the Mute switch to act as either an AF Mute (audio frequency) or an RF Mute (radio frequency). AF Mute performs a traditional audio mute. RF Mute will cut the transmitter's RF signal, which in turn mutes the receiver. This is particularly important for back-up transmitters and guitarists/bassists with multiple transmitters connected to multiple instruments and only one receiver. (Two transmitters cannot operate on the same frequency at the same time!). With RF Mute, multiple guitars can all be equipped with transmitters, all set to the same frequency, with only one active at a time. To switch instruments, simply engage the "Mute," switch instruments and "Unmute" the new instrument.

### *What are the advantages of Low Power mode on ew 300/500 G3 transmitters?*

In many instances, users think more power is better but, with respect to wireless systems, "just enough" power is best. The stronger your RF output power is, the greater chance your systems may interfere with each other. Higher RF output power also makes it more difficult to deploy large multi-channel systems. It will be possible to achieve higher channel counts in a 42 MHz switching bandwidth by decreasing your RF output power and utilizing properly designed antenna systems.

## Frequently Asked Questions (Continued)

### *What is cable emulation?*

Cable emulation allows a guitar player to add the effect of cable back into their instrument's tone. Longer cables add increasing amounts of capacitance, which can "load" the instrument's pickups. The result is a subtle but pleasing reduction of the instrument's high frequencies. When guitarists move from traditional cables to a wireless system, the sudden lack of capacitance can sound too bright or "clean". Cable emulation allows guitars to dial in three increasing levels (low / medium / high) of that familiar treble roll-off back into their sound.

### *Why can't I front-mount my antennas on the GA3 rack ears? The rack rails seem to get in the way of the two holes.*

To rack-mount the antennas on a full 19" rack unit, you will need the GA3030-AM accessory. This accessory includes two rack handle mounting pieces that will enable you to attach the female BNC bulkhead to the rack, right where there are already drilled and tapped threads. The antenna cable will pass through the rack mount, via the holes, to the back of the receiver where it will connect. More common is the use of the GA3 with the AM2. This allows one to rack mount a single system and place the antennas in the same rack space on the included blank panel.

### *How do I use the built-in guitar tuner on my ew 100 or 500 series G3 receiver?*

From the factory, the Tuner is inactive. To activate, access the receiver's menus by pressing the "SET" button. Use the up/down buttons (100 series) or jog dial (500 series) to find the "Advanced" menu and press "SET." Find "Guitar Tuner" and press "SET" again. Change the setting from "Inactive" to either "Active" or "Audio Mute." Press "SET" to store, and then tap the power button to exit to the main operating screen. With the tuner now active, use the up/down buttons or jog wheel to access the tuner screen. With the tuner set to "Active," the receiver will always pass audio as you tune. If you set the tuner to "Audio Mute," the receiver will automatically mute the audio when the tuner screen is active, allowing you to tune in silence.

### *Where's the mute switch on the handheld?*

SKM 100 / 500 G3 handheld transmitters do not have a "Mute" button. True professional microphones (wired and wireless) usually do not have a mute button, as Front of House wants to retain control over the audio. If a mute button is desired for a specific application, the SKM 300 G3 handheld transmitter does have a programmable button. You can program this model to have the mute latch on/off, or be momentary such as "push to talk" or "push to cough." In addition, you can disable it entirely.

## Conclusion

Wireless microphone and monitor systems have become standard fixtures in modern culture. Each time we turn on a television, see a performance, watch the news, go to the theatre, or enjoy a concert, we are surrounded by wireless technology. Wireless mic and monitoring systems allow you to express yourself to your audience without being constrained by cables.

Sennheiser is committed to making wireless systems powerful, yet simple to use. As such, evolution wireless G3 systems are ready to perform, right out of the box. With exceptional clarity, extended transmission range, and proven durability, evolution wireless G3 is the best choice for affordable, professional wireless performance.

## Appendix: Frequency Preset Charts

The following charts detail evolution wireless G3 ranges (A / G / B). Each range covers a 42 MHz with a total of 1,680 UHF frequencies. All evolution wireless G3 systems include 20 banks of frequency presets. All channels (frequency presets) within a bank are calculated to be intermodulation-free. Banks 1-20 are factory-preset and cannot be changed.

The "U" frequency banks (ew 100: bank "U", ew 300/ew 500: banks "U1"–"U6") allow the user to store custom frequencies, freely selectable in 25 kHz steps. These frequencies will not necessarily be intermodulation-free.

The following tables list the frequency presets in the frequency banks "1" through "20". ew 100 G3 systems include the first 12 channels in each frequency bank, ew 300 G3 series include the first 24 channels, and ew 500 G3 systems include the maximum 32 channels in each frequency bank.

For additional information about evolution wireless G3 or other Sennheiser products, please contact Sennheiser at (860) 434-9190, or visit our website: [www.sennheiserUSA.com](http://www.sennheiserUSA.com)

## Frequency Range A 516–558 MHz

US TV Channel      Ch. 21 (512–518 MHz)      Ch. 24 (530–536 MHz)      Ch. 27 (548–554 MHz)  
                                  Ch. 22 (518–524 MHz)      Ch. 25 (536–542 MHz)      Ch. 28 (554–560 MHz)  
                                  Ch. 23 (524–530 MHz)      Ch. 26 (542–548 MHz)

	Channel	Bank 1	Bank 2	Bank 3	Bank 4	Bank 5	Bank 6	Bank 7	Bank 8	Bank 9	Bank 10
ew100 ew300 ew500	1	518.200	524.250	530.100	536.350	542.900	548.850	554.100	518.125	516.000	516.000
	2	518.700	524.800	530.800	537.700	543.600	549.800	554.550	518.500	516.875	516.400
	3	519.650	525.550	531.650	538.650	544.450	550.250	555.200	519.000	517.500	517.000
	4	520.450	526.550	532.050	539.300	545.050	551.100	555.700	519.625	520.175	517.800
	5	520.900	527.700	533.050	540.100	545.450	551.500	556.450	520.375	522.625	519.000
	6	521.600	528.100	533.550	540.700	546.200	552.150	557.050	521.375	524.800	520.600
	7	522.000	529.050	534.850	541.100	546.750	552.950	557.450	523.375	529.625	522.800
	8	522.900	529.500	535.750	541.800	547.700	553.500	558.000	525.875	530.825	526.000
	9	528.800	516.950	517.300	518.900	516.900	524.050	516.300	534.125	540.525	528.400
	10	535.100	535.250	523.300	519.800	524.750	533.500	524.750	535.375	553.625	533.200
	11	552.350	536.750	547.200	550.100	551.250	537.700	533.550	537.500	516.375	537.200
	12	531.600	554.900	551.050	555.050	553.200	556.900	538.250	540.125	518.425	541.600
	13	539.900	519.200	520.150	516.150	518.100	518.950	517.200	541.750	520.975	549.000
	14	540.500	540.400	520.800	516.900	521.900	522.300	526.800	521.000	521.525	552.400
	15	542.900	541.850	521.250	524.600	522.800	523.450	529.550	522.125	523.350	519.475
	16	543.950	542.650	521.850	525.500	523.850	527.250	532.700	522.500	526.375	521.300
	17	546.050	545.150	523.900	526.550	528.450	528.400	538.950	524.125	531.400	523.850
	18	546.600	546.050	525.000	545.300	528.950	529.000	544.800	524.500	532.250	527.625
	19	550.850	547.250	553.150	546.500	531.900	532.600	547.200	525.125	533.975	530.150
	20	552.950	548.150	555.700	549.350	553.650	534.100	550.350	534.500	534.725	531.175
	21	553.700	550.400	556.900	556.250	555.000	538.300	530.250	535.000	536.200	539.950
	22	556.100	557.900	557.550	520.550	519.500	545.100	531.350	536.125	543.875	544.975
	23	524.750	527.000	528.900	523.100	521.300	521.350	534.900	536.750	545.050	547.675
	24	529.500	519.650	539.250	531.800	525.500	529.750	537.750	537.875	533.375	
	25	533.900	521.100	541.900	535.850	527.750	531.850	542.550	538.750		
	26	543.350	530.250	549.250	551.600	533.300	539.500	549.350	539.125		
	27	545.150	534.500	550.050	552.500	540.600	543.400		539.750		
	28	547.550	546.750	550.450	553.250	555.900	544.500		540.625		
	29	548.900	551.450	557.950			557.400		541.000		
	30		552.200								
	31										
	32										

**Frequency Range A 516–558 MHz (continued)**

**US TV Channel**      **Ch. 21 (512–518 MHz)**      **Ch. 24 (530–536 MHz)**      **Ch. 27 (548–554 MHz)**  
                                  **Ch. 22 (518–524 MHz)**      **Ch. 25 (536–542 MHz)**      **Ch. 28 (554–560 MHz)**  
                                  **Ch. 23 (524–530 MHz)**      **Ch. 26 (542–548 MHz)**

Channel	Bank 11	Bank 12	Bank 13	Bank 14	Bank 15	Bank 16	Bank 17	Bank 18	Bank 19	Bank 20	
ew100	1	516.100	516.200	516.000	516.150	516.275	516.375	516.100	516.000	518.100	517.500
ew300	2	516.500	516.600	516.400	516.550	516.675	516.775	516.975	516.400	518.475	517.875
ew500	3	517.100	517.200	516.900	517.050	517.175	517.275	517.600	517.000	518.975	518.375
	4	517.900	518.000	517.500	517.650	517.775	517.875	520.275	517.800	519.600	519.000
	5	519.100	519.200	517.950	518.100	518.225	518.325	522.725	519.000	520.350	519.750
	6	520.700	520.800	518.500	518.650	518.775	518.875	524.900	520.600	521.350	520.750
	7	522.900	523.000	519.150	519.300	519.425	519.525	529.725	522.800	522.975	522.375
	8	526.100	526.200	520.500	520.650	520.775	520.875	530.925	526.000	524.975	524.375
	9	528.500	528.600	521.200	521.350	521.475	521.575	540.625	528.400	527.100	526.500
	10	533.300	533.400	522.650	522.800	522.925	523.025	553.725	533.200	530.100	529.500
	11	537.300	537.400	523.400	523.550	523.675	523.775	516.475	537.200	531.350	530.750
	12	541.700	541.800	525.100	525.250	525.375	525.475	518.525	541.600	534.475	533.875
	13	549.100	549.200	526.500	526.650	526.775	526.875	521.075	549.000	537.975	537.375
	14	519.575	557.800	529.100	529.250	529.375	529.475	521.625	552.400	542.725	540.125
	15	521.400	519.675	530.900	531.050	531.175	531.275	523.450	519.475	548.350	548.125
	16	523.950	521.500	532.050	532.200	532.325	532.425	526.475	521.300	553.350	552.000
	17	527.725	524.050	533.950	534.100	534.225	534.325	531.500	523.850	521.850	521.875
	18	530.250	527.825	538.600	538.750	538.875	538.975	532.350	527.625	522.475	523.750
	19	531.275	530.350	543.150	543.300	543.425	543.525	534.075	530.150	523.850	525.500
	20	540.050	531.375	543.950	544.100	544.225	544.325	534.825	531.175	524.350	527.000
	21	545.075	540.150	547.900	548.050	548.175	548.275	536.300	539.950	527.725	527.375
	22	547.775	545.175					543.975	544.975	528.975	528.375
	23		547.875					545.150	547.675	529.475	528.750
	24							533.475	541.975	532.225	531.375
	25								543.725	532.725	531.875
	26								546.550	538.475	533.375
	27									539.100	538.125
	28									539.600	538.625
	29									540.975	540.500
	30									542.225	542.625
	31									543.850	
	32										

## Frequency Range G 566–608 MHz

US TV Channel      **Ch. 30 (566–572 MHz)**      **Ch. 33 (584–590 MHz)**      **Ch. 36 (602–608 MHz)**  
                                  **Ch. 31 (572–578 MHz)**      **Ch. 34 (590–596 MHz)**  
                                  **Ch. 32 (578–584 MHz)**      **Ch. 35 (596–602 MHz)**

	Channel	Bank 1	Bank 2	Bank 3	Bank 4	Bank 5	Bank 6	Bank 7	Bank 8	Bank 9	Bank 10
ew100 ew300 ew500	1	566.450	572.400	578.400	584.400	590.700	596.400	602.250	566.000	566.000	566.100
	2	566.950	573.100	579.300	584.900	591.550	596.800	602.800	566.875	566.400	566.500
	3	567.900	574.100	579.700	585.550	592.600	597.500	603.200	567.500	567.000	567.100
	4	568.350	574.950	580.750	586.000	593.400	598.000	604.300	570.175	567.800	567.900
	5	569.500	576.150	581.200	586.850	593.950	599.400	605.100	572.625	569.000	569.100
	6	570.050	576.550	582.400	587.400	594.700	600.050	605.550	574.800	570.600	570.700
	7	570.850	577.200	583.250	588.600	595.100	601.050	606.550	579.625	572.800	572.900
	8	571.250	577.650	583.800	589.500	595.700	601.600	607.700	580.825	576.000	576.100
	9	584.300	567.900	568.100	567.250	571.100	570.200	568.250	590.525	578.400	578.500
	10	591.550	581.850	568.700	574.450	578.450	575.900	574.850	601.700	583.200	583.300
	11	604.250	597.000	592.250	598.000	584.450	581.750	580.700	603.625	587.200	587.300
	12	606.450	607.750	603.500	601.150	605.600	585.050	587.900	608.000	591.600	591.700
	13	572.800	566.150	573.800	567.850	566.450	566.450	566.300	566.375	599.000	599.100
	14	577.900	566.950	575.150	568.900	567.650	567.800	567.350	567.900	602.400	602.500
	15	580.150	580.900	587.450	571.600	568.100	568.250	571.700	568.425	607.600	607.700
	16	586.550	586.700	597.200	572.200	569.900	569.600	572.450	569.125	568.175	568.275
	17	589.750	590.300	597.950	573.850	571.550	571.700	574.100	569.575	569.475	569.575
	18	593.550	593.100	600.200	580.750	572.750	573.500	575.900	570.975	571.300	571.400
	19	595.050	595.250	600.950	582.100	576.800	577.850	578.900	571.525	573.850	573.950
	20	596.700	601.300	602.750	595.750	583.550	578.600	582.800	573.350	577.625	577.725
	21	599.550	602.100	604.100	598.600	586.100	589.550	591.350	576.375	580.150	580.250
	22	601.050	602.650	605.900	601.750	600.050	594.650	593.450	581.400	581.175	581.275
	23	603.250	606.000	606.500	603.550	603.950	605.000	597.500	582.250	589.950	590.050
	24	607.750	606.950	607.850	606.100	605.150	606.050	598.550	583.975	594.975	595.075
	25	574.900	569.350	569.900	566.500	566.900	572.900	568.850	584.725	597.675	597.775
	26	582.650	570.250	571.550	570.400	573.500	574.250	570.500	586.200	600.975	601.075
	27	593.150	583.350	572.750	574.900	574.700	576.500	571.250	593.875	601.900	602.000
	28	594.200	583.900	575.750	590.800	577.700	580.400	576.800	595.050	604.625	604.725
	29	596.200	590.800	584.600	591.850	600.950	580.850	582.200	600.625	605.250	605.350
	30	597.550	594.500	594.650	593.200	602.150	590.300	583.850	601.275	604.125	604.225
	31	603.850	603.550	598.550	600.100	606.500	602.900	596.300	607.050	603.375	603.475
	32	607.200	604.600	607.400	607.900	607.700	607.250	601.100	583.375		

## Frequency Range G 566–608 MHz (continued)

US TV Channel	Ch. 30 (566–572 MHz) Ch. 31 (572–578 MHz) Ch. 32 (578–584 MHz)	Ch. 33 (584–590 MHz) Ch. 34 (590–596 MHz) Ch. 35 (596–602 MHz)	Ch. 36 (602–608 MHz)								
Channel	Bank 11	Bank 12	Bank 13	Bank 14	Bank 15	Bank 16	Bank 17	Bank 18	Bank 19	Bank 20	
ew100 ew300 ew500	1	566.200	566.000	566.125	566.275	566.375	566.150	607.850	566.100	568.100	567.500
	2	566.600	566.400	566.525	566.675	566.775	566.525	607.475	566.975	568.475	567.875
	3	567.200	566.900	567.025	567.175	567.275	566.975	607.025	567.600	568.975	568.375
	4	568.000	567.500	567.625	567.775	567.875	567.500	606.500	570.275	569.600	569.000
	5	569.200	567.950	568.075	568.225	568.325	568.100	605.900	572.725	570.350	569.750
	6	570.800	568.500	568.625	568.775	568.875	568.775	605.225	574.900	571.350	570.750
	7	573.000	569.150	569.275	569.425	569.525	569.525	604.475	579.725	572.975	572.375
	8	576.200	570.500	570.625	570.775	570.875	570.425	603.575	580.925	574.975	574.375
	9	578.600	571.200	571.325	571.475	571.575	571.625	602.375	590.625	577.100	576.500
	10	583.400	572.650	572.775	572.925	573.025	573.125	600.875	601.800	580.100	579.500
	11	587.400	573.400	573.525	573.675	573.775	574.850	599.150	603.725	581.350	580.750
	12	591.800	575.100	575.225	575.375	575.475	577.325	596.675	566.475	584.475	583.875
	13	599.200	576.500	576.625	576.775	576.875	580.400	593.600	568.000	587.975	587.375
	14	602.600	579.100	579.225	579.375	579.475	582.575	591.425	568.525	592.725	590.125
	15	607.800	580.900	581.025	581.175	581.275	585.350	588.650	569.225	598.350	598.125
	16	568.375	582.050	582.175	582.325	582.425	589.025	584.975	569.675	603.350	602.000
	17	569.675	583.950	584.075	584.225	584.325	592.175	581.825	571.075	606.100	607.000
	18	571.500	588.600	588.725	588.875	588.975	596.675	577.325	571.625	571.850	571.250
	19	574.050	593.150	593.275	593.425	593.525	598.550	575.450	573.450	572.475	571.875
	20	577.825	593.950	594.075	594.225	594.325	601.850	572.150	576.475	573.850	573.750
	21	580.350	597.900	598.025	598.175	598.275	605.675	568.325	581.500	574.350	575.500
	22	581.375	600.250	600.375	600.525	600.625	606.725	567.275	582.350	577.725	577.000
	23	590.150	601.200	601.325	601.475	601.575	607.900	566.100	584.075	578.975	577.375
	24	595.175	606.300	606.425	606.575	606.675	607.275	566.725	584.825	579.475	578.375
	25	597.875	607.550	607.675	607.825	607.925	603.300	570.700	586.300	582.225	578.750
	26	601.175					602.500	571.500	593.975	582.725	581.375
	27	602.100					595.725	578.275	595.150	588.475	581.875
	28	604.825					589.725	584.275	600.725	589.100	583.375
	29	605.450					584.575	589.425	601.375	589.600	588.125
	30	604.325					579.000	595.000	607.150	590.975	588.625
	31	603.575					575.275	598.725	583.475	592.225	590.500
	32						569.925	604.075		593.850	592.625

## Frequency Range B 626–668 MHz

US TV Channel      **Ch. 40 (626–632 MHz)**      **Ch. 43 (644–650 MHz)**      **Ch. 46 (662–668 MHz)**  
                                  **Ch. 41 (632–638 MHz)**      **Ch. 44 (650–656 MHz)**  
                                  **Ch. 42 (638–644 MHz)**      **Ch. 45 (656–662 MHz)**

	Channel	Bank 1	Bank 2	Bank 3	Bank 4	Bank 5	Bank 6	Bank 7	Bank 8	Bank 9	Bank 10
ew100	1	626.300	632.350	638.450	644.550	650.200	656.350	662.750	632.925	626.000	626.000
ew300	2	626.750	632.800	639.050	645.450	650.750	656.800	663.150	635.425	626.875	626.400
ew500	3	627.450	633.750	639.450	646.650	651.600	657.450	663.950	639.350	627.500	627.000
	4	628.450	634.350	640.200	647.200	652.800	657.850	664.500	640.050	630.175	627.800
	5	628.900	635.700	640.750	648.050	653.250	659.050	665.650	648.500	632.625	629.000
	6	629.700	636.200	641.550	648.500	654.300	659.900	666.100	653.950	634.800	630.600
	7	630.800	636.900	642.600	649.150	654.700	660.900	667.050	655.350	639.625	632.800
	8	631.750	637.300	643.450	649.650	655.600	661.600	667.550	656.250	640.825	636.000
	9	640.550	628.850	628.550	630.500	630.500	626.250	627.550	659.025	650.525	638.400
	10	646.100	641.600	649.700	636.050	641.750	637.000	629.750	665.175	661.700	643.200
	11	653.300	647.150	655.700	659.600	665.300	640.900	642.450	665.675	663.625	647.200
	12	659.150	665.300	663.050	666.800	665.900	652.150	649.700	667.275	668.000	651.600
	13	635.450	643.100	629.000	627.950	626.150	627.050	626.250	631.200	626.375	659.000
	14	636.500	643.850	630.200	632.300	627.500	628.000	630.750	633.750	627.900	662.400
	15	642.650	648.200	634.100	632.900	628.100	631.350	632.950	636.025	628.425	667.600
	16	651.200	652.250	648.050	635.450	629.900	631.900	634.450	638.500	629.125	628.175
	17	655.100	653.000	650.600	638.300	631.250	632.700	637.300	640.450	629.575	629.475
	18	658.100	656.450	657.350	651.950	633.050	638.750	638.950	643.650	630.975	631.300
	19	659.900	658.250	661.400	653.300	633.800	643.700	640.450	653.000	631.525	633.850
	20	661.550	661.250	662.600	660.200	636.050	647.300	644.250	655.875	633.350	637.625
	21	662.300	662.300	664.250	661.850	636.800	653.100	647.450	660.050	636.375	640.150
	22	665.750	663.050	666.050	662.450	646.550	666.100	653.850	661.200	641.400	641.175
	23	666.650	664.550	666.500	665.150	658.850	667.050	656.100	662.500	642.250	649.950
	24	667.700	666.950	667.700	666.200	660.200	667.850	661.200	667.700	643.975	654.975
	25	632.900	626.150	626.450	626.150	626.600	629.400	626.800	636.750	644.725	657.675
	26	638.150	626.900	627.650	633.950	635.450	630.450	630.150	641.425	646.200	660.975
	27	646.850	628.100	632.000	640.850	639.350	636.250	636.450	651.150	653.875	661.900
	28	650.150	641.150	633.200	642.200	649.400	639.500		637.800	655.050	664.625
	29	651.800	653.600	656.450	643.250	658.250	643.250		639.800	660.625	665.250
	30	656.150	655.700	659.450	659.150	661.250	650.650		640.850	661.275	664.125
	31	663.500	660.350	660.650	663.650	662.450	663.700		651.350	667.050	663.375
	32	664.550	665.900	667.250	667.550	664.100	664.500		659.100	643.375	



**Frequency Range B 626–668 MHz (continued)**

US TV Channel      **Ch. 40 (626–632 MHz)**      **Ch. 43 (644–650 MHz)**      **Ch. 46 (662–668 MHz)**  
                                  **Ch. 41 (632–638 MHz)**      **Ch. 44 (650–656 MHz)**  
                                  **Ch. 42 (638–644 MHz)**      **Ch. 45 (656–662 MHz)**

Channel	Bank 11	Bank 12	Bank 13	Bank 14	Bank 15	Bank 16	Bank 17	Bank 18	Bank 19	Bank 20
1	626.100	626.200	626.050	626.175	626.300	626.375	626.150	667.850	626.100	628.100
2	626.500	626.600	626.450	626.575	626.700	626.775	626.525	667.475	626.975	628.475
3	627.100	627.200	626.950	627.075	627.200	627.275	626.975	667.025	627.600	628.975
4	627.900	628.000	627.550	627.675	627.800	627.875	627.500	666.500	630.275	629.600
5	629.100	629.200	628.000	628.125	628.250	628.325	628.100	665.900	632.725	630.350
6	630.700	630.800	628.550	628.675	628.800	628.875	628.775	665.225	634.900	631.350
7	632.900	633.000	629.200	629.325	629.450	629.525	629.525	664.475	639.725	632.975
8	636.100	636.200	630.550	630.675	630.800	630.875	630.425	663.575	640.925	634.975
9	638.500	638.600	631.250	631.375	631.500	631.575	631.625	662.375	650.625	637.100
10	643.300	643.400	632.700	632.825	632.950	633.025	633.125	660.875	661.800	640.100
11	647.300	647.400	633.450	633.575	633.700	633.775	634.850	659.150	663.725	641.350
12	651.700	651.800	635.150	635.275	635.400	635.475	637.325	656.675	626.475	644.475
13	659.100	659.200	636.550	636.675	636.800	636.875	640.400	653.600	628.000	647.975
14	662.500	662.600	639.150	639.275	639.400	639.475	642.575	651.425	628.525	652.725
15	667.700	667.800	640.950	641.075	641.200	641.275	645.350	648.650	629.225	658.350
16	628.275	628.375	642.100	642.225	642.350	642.425	649.025	644.975	629.675	663.350
17	629.575	629.675	644.000	644.125	644.250	644.325	652.175	641.825	631.075	666.100
18	631.400	631.500	648.650	648.775	648.900	648.975	656.675	637.325	631.625	631.850
19	633.950	634.050	653.200	653.325	653.450	653.525	658.550	635.450	633.450	632.475
20	637.725	637.825	654.000	654.125	654.250	654.325	661.850	632.150	636.475	633.850
21	640.250	640.350	657.950	658.075	658.200	658.275	665.675	628.325	641.500	634.350
22	641.275	641.375	660.300	660.425	660.550	660.625	666.725	627.275	642.350	637.725
23	650.050	650.150	661.250	661.375	661.500	661.575	629.925	626.100	644.075	638.975
24	655.075	655.175	666.350	666.475	666.600	666.675	635.275	626.725	644.825	639.475
25	657.775	657.875	667.600	667.725	667.850	667.925	639.000	630.700	646.300	642.225
26	661.075	661.175					644.575	631.500	653.975	642.725
27	662.000	662.100					649.725	638.275	655.150	648.475
28	664.725	664.825					655.725	644.275	660.725	649.100
29	665.350	665.450					662.500	649.425	661.375	649.600
30	664.225	664.325					663.300	655.000	667.150	650.975
31	663.475	663.575					667.275	658.725	643.475	652.225
32							667.900	664.075		653.850

## Notes:





[www.sennheiserUSA.com](http://www.sennheiserUSA.com)

**Sennheiser Electronic Corporation**  
One Enterprise Drive, Old Lyme, CT 06371  
Tel: (860) 434-9190 • Fax: (860) 434-1759

Latin America: Tel: 52-55-5639-0956 • Fax: 52-55-5639-9482

Canada: Tel: (514) 426-3013 Fax: (514) 426-3953  
[www.sennheiser.ca](http://www.sennheiser.ca)

Revised: 04/2012

## Free Manuals Download Website

<http://myh66.com>

<http://usermanuals.us>

<http://www.somanuals.com>

<http://www.4manuals.cc>

<http://www.manual-lib.com>

<http://www.404manual.com>

<http://www.luxmanual.com>

<http://aubethermostatmanual.com>

Golf course search by state

<http://golfingnear.com>

Email search by domain

<http://emailbydomain.com>

Auto manuals search

<http://auto.somanuals.com>

TV manuals search

<http://tv.somanuals.com>