

# tourguide UHF

Instructions for use

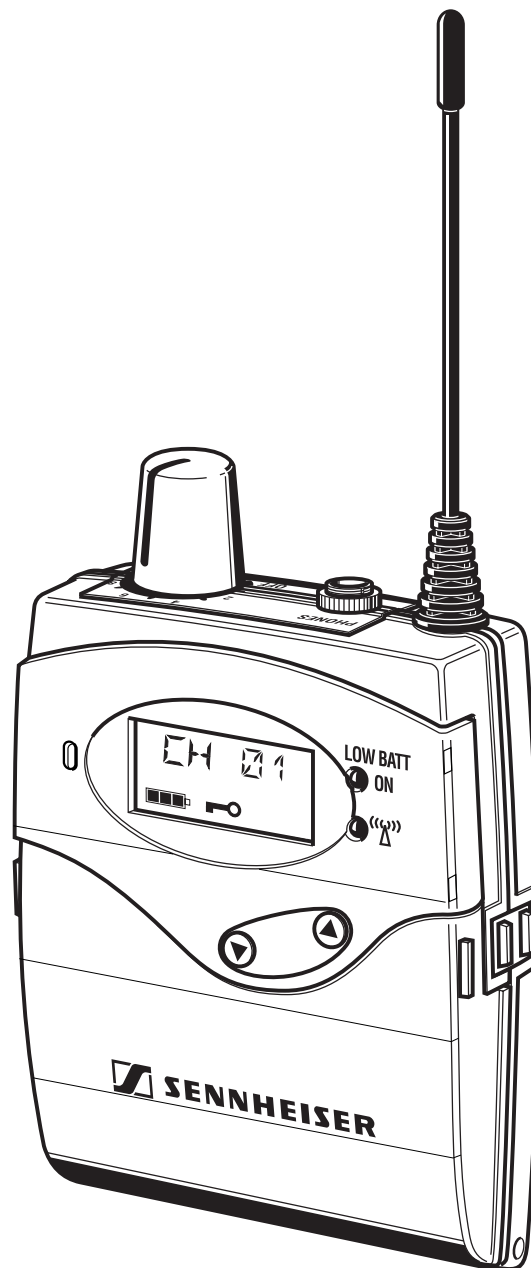



# Contents

<b>Important safety instructions</b> .....	5
<b>The tourguide UHF system</b> .....	8
<b>System components</b> .....	8
<b>EK 1038 receiver</b> .....	9
Special features .....	9
Operating controls .....	9
Indications .....	10
Preparing for use .....	11
<b>Using the receiver</b> .....	12
The operating menu of the receiver .....	13
Configure the receiver .....	13
Operating menu of the receiver .....	16
Adjustment tips for the setup menu .....	18
Locking channels for the user .....	18
Adjusting the squelch threshold .....	19
Limiting the volume at the headphone output .....	20
<b>L 2015 quick charger</b> .....	22
Special features .....	22
Operating controls .....	23
Preparing for use .....	24
Using the charger .....	25
Care and maintenance .....	25
The channel bank system .....	26
<b>SKM 100 G2 / SKM 300 G2 / SKM 500 G2 radiomicrophones</b> .....	28
Delivery includes .....	28
Operating Controls .....	28
Preparing for use .....	29
Using the radiomicrophone .....	30
Care and maintenance .....	31
<b>SK 100 G2 / SK 300 G2 / SK 500 G2 bodypack transmitters</b> .....	32
Delivery includes .....	32
Operating Controls .....	32
Preparing for use .....	32
Using the bodypack transmitter .....	35
<b>SKP 100 G2 / SKP 500 G2 plug-on transmitters</b> .....	36
Delivery includes .....	36
Operating Controls .....	36
Preparing for use .....	37
<b>LC display panel of the evolution wireless transmitters G 2</b> .....	39
<b>The operating menu of the transmitters evolution wireless series G 2</b> 41	
Overview of menus .....	41
The buttons .....	41
Working with the operating menu .....	42
Overview of the operating menu of the transmitters .....	43
<b>Adjustment tips for the operating menu</b> .....	45
Switching between channel banks .....	45

Switching between the channels in a channel bank .....	45
Selecting the frequencies to be stored in the channel bank "U" ....	45
Adjusting the sensitivity .....	45
Switching the phantom powering on/off (SKP 500 G2 only) .....	46
Selecting the standard display .....	47
Entering a name .....	47
Loading the factory-preset default settings .....	47
Activating/deactivating the pilot tone transmission (PILOT) .....	48
Activating/deactivating the lock mode .....	48
Exiting the operating menu .....	48
<b>Troubleshooting</b> .....	<b>49</b>
Error checklist .....	49
<b>Recommendations and tips</b> .....	<b>50</b>
<b>HDX noise reduction</b> .....	<b>51</b>
<b>Accessories and spare parts</b> .....	<b>52</b>
EK 1038 receiver .....	52
L 2015 quick charger .....	52
Transmitters of the evolution wireless series, G 2 .....	52
<b>Specifications</b> .....	<b>54</b>
EK 1038 receiver .....	54
L 2015 charger .....	54
Plug-in mains units .....	55
evolution wireless transmitters G 2 .....	55
Channel assignment .....	56
<b>Manufacturer declarations</b> .....	<b>57</b>

Thank you for choosing Sennheiser!

We have designed this product to give you reliable operation over many years. Over 60 years of accumulated expertise in the design and manufacture of high-quality electro-acoustic equipment have made Sennheiser a world-leading company in this field.

Please take a few moments to read these instructions carefully, as we want you to enjoy your new Sennheiser products quickly and to the fullest.

## Important safety instructions

1. Read these instructions.
2. Keep these instructions.
3. Heed all warnings.
4. Follow all instructions.
5. Do not use this apparatus near water.
6. Clean only with dry cloth.
7. Do not block any ventilation openings. Install in accordance with the manufacturer's instructions.
8. Do not install near any heat sources such as radiators, heat registers, stoves, or other apparatus (including amplifiers) that produce heat.
9. Do not defeat the safety purpose of the polarized or grounding-type plug. A polarized plug has two blades with one wider than the other. A grounding type plug has two blades and a third grounding prong. The wide blade or the third prong are provided for your safety. If the provided plug does not fit into your outlet, consult an electrician for replacement of the obsolete outlet.
10. Protect the power cord from being walked on or pinched, particularly at plugs, convenience receptacles, and the point where they exit from the apparatus.
11. Only use attachments/accessories specified by the manufacturer.
12. Use only with the cart, stand, tripod, bracket, or table specified by the manufacturer, or sold with the apparatus. When a cart is used, use caution when moving the cart/apparatus combination to avoid injury from tip-over. 
13. Unplug this apparatus during lightning storms or when unused for long periods of time.
14. Refer all servicing to qualified service personnel. Servicing is required when the apparatus has been damaged in any way, such as power supply cord or plug is damaged, liquid has been spilled or objects have fallen into the apparatus, when the apparatus has been exposed to rain or moisture, does not operate normally, or has been dropped.
15. To completely disconnect this apparatus from the AC mains, disconnect the power supply cord plug from the AC receptacle.
16. **WARNING:** To reduce the risk of fire or electric-shock, do not expose this apparatus to rain or moisture.
17. Do not expose this equipment to dripping or splashing and ensure that no objects filled with liquids, such as vases, are placed on the equipment.
18. The mains plug of the power supply cord shall remain readily operable.

### Power source

This device should be operated only from the type of power source indicated on the type plate. If you are not sure of the type of power supply to your building, consult your dealer or local power company.

### Overloading

Do not overload wall outlets and extension cords as this may result in fire and electric shock.

### Replacement parts

When replacement parts are required, be sure the service technician has used replacement parts specified by the manufacturer or those having the same characteristics as the original part. Unauthorized substitutions may result in fire, electric shock, or other hazards.

### Safety check

Upon completion of any service or repairs to this device, ask the service technician to perform safety checks to determine that the device is in safe operating order.

### Danger of hearing damage due to high volumes

This is a professional system. Commercial use is subject to the rules and regulations of the trade association responsible. Sennheiser, as the manufacturer, is therefore obliged to expressly point out possible health risks arising from use.

This system is capable of producing sound pressure exceeding 85 dB(A). 85 dB(A) is the sound pressure corresponding to the maximum permissible volume which is by law (in some countries) allowed to affect your hearing for the duration of a working day. It is used as a basis according to the specifications of industrial medicine. Higher volumes or longer durations can damage your hearing. At higher volumes, the duration must be shortened in order to prevent hearing damage. The following are sure signs that you have been subjected to excessive noise for too long a time:

- You can hear ringing or whistling sounds in your ears.
- You have the impression (even for a short time only) that you can no longer hear high notes.

### Intended use of the devices

Intended use of the devices includes:

- using the device for professional purposes,
- having read these instructions, especially the chapter see „Important safety instructions“ on page 5,
- using the device within the operating conditions and limitations described in this instruction manual.

“Improper use” means using the devices other than as described in these instructions, or under operating conditions which differ from those described herein.

## Safety instructions for Lithium-Ion rechargeable batteries

If abused or misused, rechargeable batteries may leak. In extreme cases, they may even



- heat hazard
- fire hazard
- explosion hazard
- smoke and gas hazard

Please understand that Sennheiser does not accept liability for damage arising from abuse or misuse.



Keep away from children.



Observe correct polarity.



Do not heat above 70°C/158°F, e.g. do not expose to sunlight or throw into a fire.



Switch rechargeable battery-powered devices off after use.



Do not expose to moisture.



Remove rechargeable batteries when the unit is not used for extended periods of time.



Do not short-circuit.



When not using rechargeable batteries for extended periods of time, charge them regularly (about every three months).



Do not mutilate or dismantle.



Only charge rechargeable batteries at ambient temperatures between 10°C and 40°C.



Do not get fully charged but unpacked rechargeable batteries mixed up.



Immediately remove rechargeable batteries from obviously defective devices.



Do not continue to use defective rechargeable batteries.



Dispose of rechargeable batteries at special collection points or return them to your specialist dealer.



Only use original Sennheiser rechargeable batteries.

## Additional safety instructions for the BA 2015 accupack and for batteries



Do not solder.



Immediately remove flat batteries/rechargeable batteries from the device.

## The tourguide UHF system

The tourguide UHF system consists of the EK 1038 receiver in combination with a transmitter of the evolution wireless series G2. The system offers optimum speech transmission for guided tours and interpretation applications with one or several speakers. The use of RF transmission allows freedom of movement for all members of the group. Due to the possibility of combining the EK 1038 receiver with different transmitters, the system can be optimally adapted to your individual needs.

The system has superb audio quality with an increased signal-to-noise ratio and dynamic range due to the inclusion of Sennheiser's **HDX** noise reduction system.

## System components

The components of the system are:

- EK 1038 receiver
- BA 2015 accupack
- L 2015 charger
- NT 1 or NT 3 plug-in mains unit
- GP 03 headphones with stereo jack plug
- transmitter (please specify when ordering)



# EK 1038 receiver

## Special features

The EK 1038 receiver is a small and reliable bodypack receiver that can easily be attached to the clothing by the means of a belt clip. 16 factory-preset UHF frequencies which are intermodulation-free and four freely selectable frequencies ensure a high level of flexibility and operational reliability. In combination with the HDX noise reduction it provides for a safe transmission.

The receiver is characterized by

- Easy use
- Channel-indication via display
- Channel adjustment via rocker button
- LED operation indication
- LED and display "LowBattery" indication
- LED receiving indication

## Operating controls

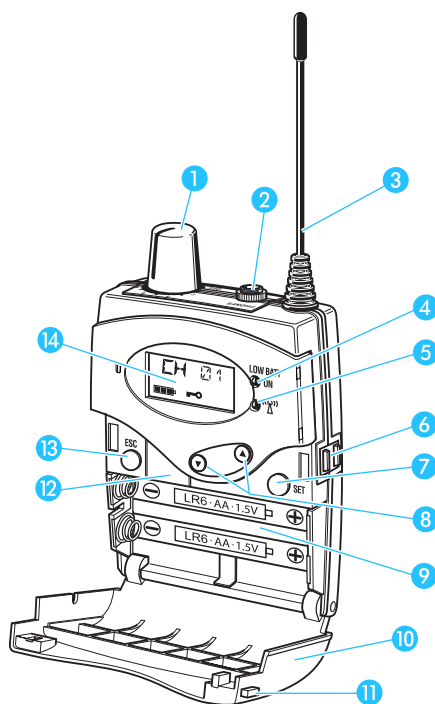

- 1 Volume control and On/Off button
- 2 3.5 mm jack socket for headphones
- 3 Receiving antenna
- 4 Red LED for operation and battery status indication (LOW BATT/ON)
- 5 Green LED for RF signal indication
- 6 Charging contacts
- 7 SET button
- 8 ▲/▼ rocker button (UP/DOWN)
- 9 Battery compartment cover
- 10 Battery compartment cover
- 11 Unlocking button
- 12 Infra-red interface
- 13 ESC button
- 14 Display

## Indications

- ① Alphanumeric display
- ② 4-step battery status display
- ③ Lock mode icon (lock mode is activated)

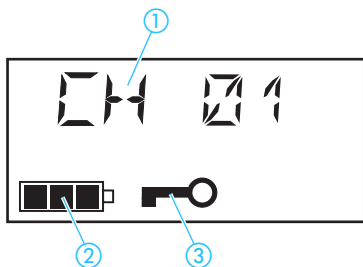

### Operation and battery status indication

The red LED (LOW BAT/ON) ④ provides information on the current operating state of the receiver:

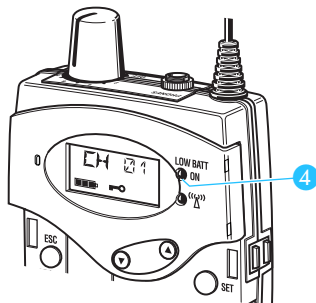

Red LED lit up: The receiver is switched on and the capacity of the batteries/rechargeable battery BA 2015 is sufficient.

Red LED flashing: The batteries are/the rechargeable battery BA 2015 is going flat (LOW BAT)!

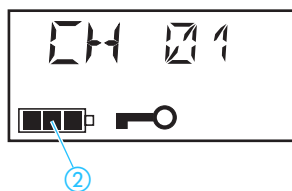

In addition, the 4-step battery status display ② on the display panel provides information on the remaining battery/rechargeable battery BA 2015 capacity:

- 3 segments: capacity approx. 100 %
- 2 segments: capacity approx. 70 %
- 1 segment: capacity approx. 30 %
- Battery icon flashing: LOW BAT

### RF signal indication

The green LED (RF) ⑤ at the front of the receiver lights up when an RF signal is being received.

However, the green LED (RF) does not light up when the audio output is muted because the RF signal of the received transmitter is too weak.

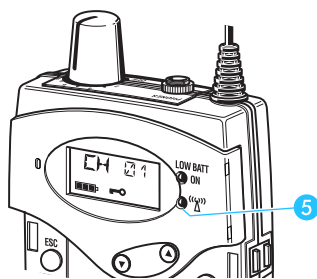

### Display backlighting

After pressing a button, the display remains backlit for approx. 15 seconds.

## Preparing for use

### Inserting and changing the battery pack/batteries

For powering the units, we recommend using the supplied BA 2015 battery pack. The battery pack can be recharged in the L 2015 charger while remaining in the receiver (see "Charging the rechargeable battery BA 2015" on page 27).

Accupacks ensure economical and environmentally friendly operation of the tourguide UHF system during daily use.

If no power supply is available for recharging the battery pack, you can alternatively use 1.5 V AA size batteries.

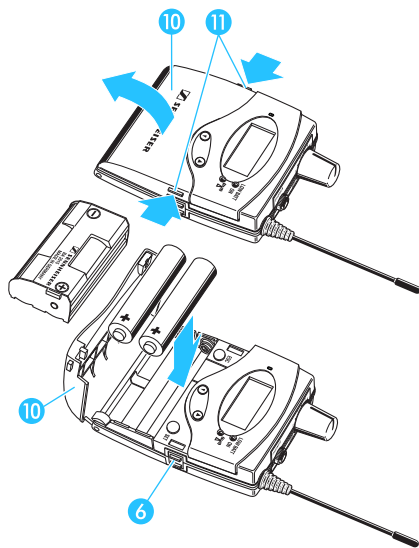

- ▶ Press the two unlocking buttons 11 and open the battery compartment cover 10.
- ▶ Insert the battery pack or the batteries as shown on the left. Please observe correct polarity when inserting the battery pack or the batteries.
- ▶ Close the battery compartment. The battery compartment cover 10 locks into place with an audible click.

### How to properly use the battery pack or the batteries

For battery pack operation, only use the BA 2015 battery pack in order to ensure optimum operational reliability. Batteries and rechargeable battery cells have different discharging curves. The receiver is able to identify the BA 2015 battery pack and to use it to full capacity. It also adapts the battery status display according to the type of power supply used (batteries or battery pack). Individual rechargeable battery cells will not be identified as battery packs.

- ▶ After use (e.g. during the night), charge the BA 2015 battery pack of the receiver in the L 2015 charger. The charging time is approx. 2.5 hours, at which time the unit then switches to trickle charging.
- ▶ If you do not use the receiver for extended periods of time (e.g. while you are on holiday), remove the battery pack or the batteries. After three months at the latest, the battery packs will need a refresh charge in the L 2015 charger. This prevents damage to the battery pack due to self-discharge.

### Connecting the headphones

You must only connect headphones with a stereo jack plug and a minimum impedance of 8  $\Omega$  to the receiver.

- ▶ Connect the headphones to the receiver's 3.5 mm jack socket (PHONES) 2.

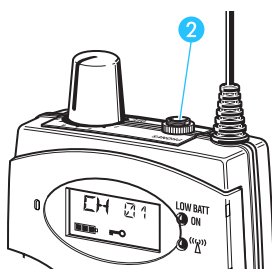

## Using the receiver

### Switching the receiver on/off

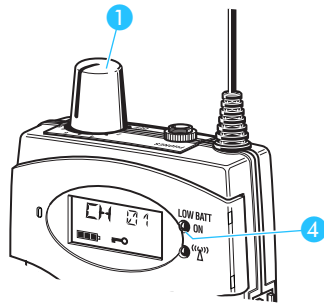

- ▶ To switch the receiver on, turn the volume control **1** clockwise until it clicks. The red LED **4** lights up and the current number is displayed.

#### Note:

- The receiver has a short switch-on delay.
- Remove the batteries or the rechargeable battery when the receiver will not be used for extended periods of time.

- ▶ To switch the receiver off, turn the volume control **1** counter-clockwise until it clicks. The red LED **4** and the standard display go off.

#### Note:

If you insert the active receiver into the L 2015 charger to recharge it, the receiver automatically gets off. It even remains inactivated when you take it out of the charger. Then you will have to primary switch it off and then on again as described above.

### Adjusting the volume

You can adjust the volume at the headphone output on the transmitter.

#### CAUTION! Danger of hearing damage!



Listening at high volume levels for long periods can lead to permanent hearing defects.

- ▶ Set the volume for the connected headphones to the minimum before putting the headphones on.

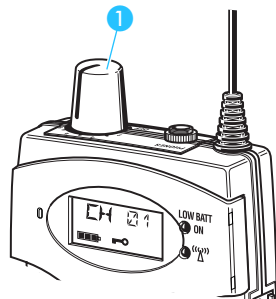

- ▶ Adjust the volume of the connected headphones via the volume control button **1** so that you can clearly and precisely understand the speaker.

### Switching the channel

If several guided tours take place within a building and several transmission links are operated at the same time, the user can switch the channel of the receiver to the channel that is stated by the guide.

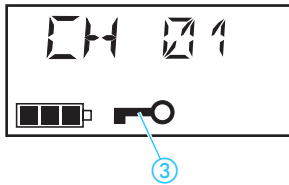

### Note:

It is only possible to switch the channel if the lock mode is deactivated. If it is deactivated, no lock mode icon ③ appears on the display (see "Activating/deactivating the lock mode" on page 20).

- ▶ Use the ▲/▼ rocker button (UP/DOWN) ⑧ to switch between the 20 channels maximum.

The number of selectable channels might be limited when the operator has locked several channels (see "Locking channels for the user" on page 20). Locked channels are not displayed.

The receiver immediately switches to the new channel. If a transmission signal is received on the new channel the green LED ⑤ lights up.

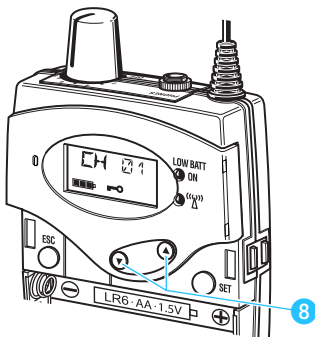

### Attaching the receiver to clothing

- ▶ The receiver is attached to clothing (e.g. belt, waistband) with the supplied belt clip.

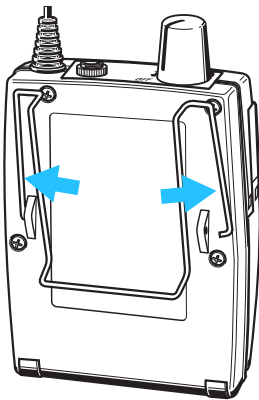

## The operating menu of the receiver

The operating menu of the receiver consists of the user menu and the setup menu.

Within the user menu, the user can switch between the channels via the ▲/▼ rocker button (see "Switching the channel" on page 13).

Within the setup menu, the operator can configure the receiver for daily use.

## SETUP

### Configure the receiver

This section describes how to use the setup menu. An overview over the menu is given within the chapter "The setup menu of the receiver" on page 19.

### Starting the setup menu

In order to get into the configuration menu, the receiver must be switched off.

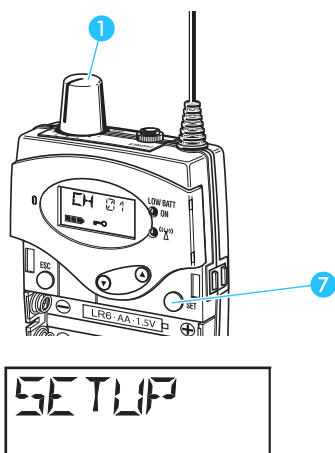

- ▶ Open the battery compartment.
- ▶ Press the SET button **7** and keep it pressed.
- ▶ At the same time, turn the volume control **1** clockwise until it clicks to switch the receiver on. The "SETUP" display appears on the display panel.

### Function of the buttons in the setup menu

Buttons	Mode	To ...
SET	Start display	get from the start display "SETUP" to the operating menu of the setup menu
	Operating menu	get into the setting mode of the selected menu
	Setting mode	store the settings and return to the top menu level
▲/▼	Start display	without function
	Operating menu	change to the previous menu (▲) or change to the next menu (▼)
	Setting mode	adjust the setting of the selected menu: option (▲/▼)
ESC	Start display	without function
	Operating menu	cancel the adjustment and return to the start display "SETUP"
	Setting mode	cancel the entry and return to the start display "SETUP"

## Getting into the operating menu of the setup menu

- ▶ Press the **SET** button **7** to get from the start display into the operating menu. The first menu "LOCK" flashes on the display.

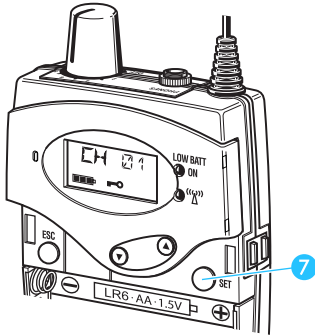

## Selecting a menu

- ▶ Press the **▲/▼** rocker button (UP/DOWN) to select the menu you would like to adjust the setting.  
The current setting that can be adjusted flashes on the display.

The setup menu comprises six menus that can be chosen in the following order:

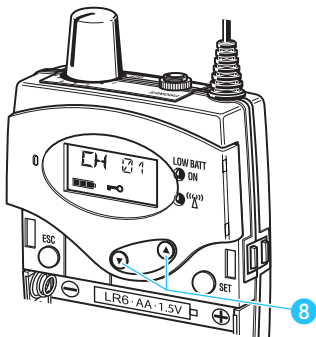

Display	Function of the menu
LOCK	Activating/deactivating the lock mode (see page 20)
TUNE	Setting a receiving frequency for the channels (see page 20) and locking channels for the user (see page 20)
SQELCH	Adjusting the squelch threshold (see page 21)
LTD	Activating/deactivating the limiter at the headphone output (see page 22)
SW-REV	Displaying the revision of the firmware* (see "SW-REV" on page 22) *software stored on a chip in the device
COPY	Setting several receivers to the same channel and receiver settings simultaneously (see "COPY" on page 22)

## Getting into the setting mode of a menu

- ▶ Press the **SET** **7** button to get into the setting mode of the selected menu.  
The current setting that can be adjusted flashes on the display.

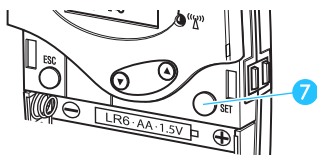

### Adjusting a setting

- ▶ Press the ▲/▼ (UP/DOWN) 8 rocker button to adjust the setting of the menu.  
The new setting flashes on the display.
- ▶ By briefly pressing the rocker button, the display jumps either forwards or backwards to the next setting. In the "TUNE" menu, the rocker button features a "fast search" function: If you hold down the ▲ or ▼ button, the display cycles continuously, allowing you to get fast and easily to your desired setting. The new setting flashes on the display until it is stored.

### Storing a setting



- ▶ Press the SET button 7 to store the setting. "STORED" appears on the display, indicating that the setting has been stored. You return to the operating menu of the setup menu. The last menu selected flashes on the display.

### Canceling the entry

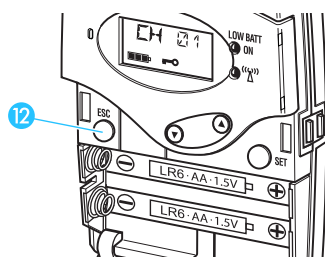

Press the ESC button 12 to cancel the entry. With the menus "LOCK", "SQUELCH", "LTD", "SW-REV" and "COPY" you return to the start display "SETUP". The last menu remains unchanged.

An exception is the "TUNE" menu. When canceling the entry with this menu, you will stay in the setting mode of the menu but you return to the display of the current channel (e.g. "CH 01"). It is then possible to restart your entry.

### Exiting the setup menu

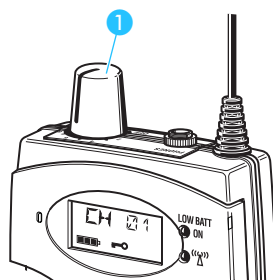

- ▶ Switch the receiver off to exit the setup menu. To do so, turn the volume control 1 counterclockwise until it clicks  
If you then restart the receiver you get into the user menu and the current channel is displayed.

## Operating menu of the receiver

### The user menu of the receiver

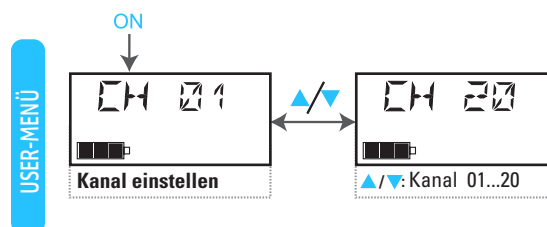



The setup menu of the receiver

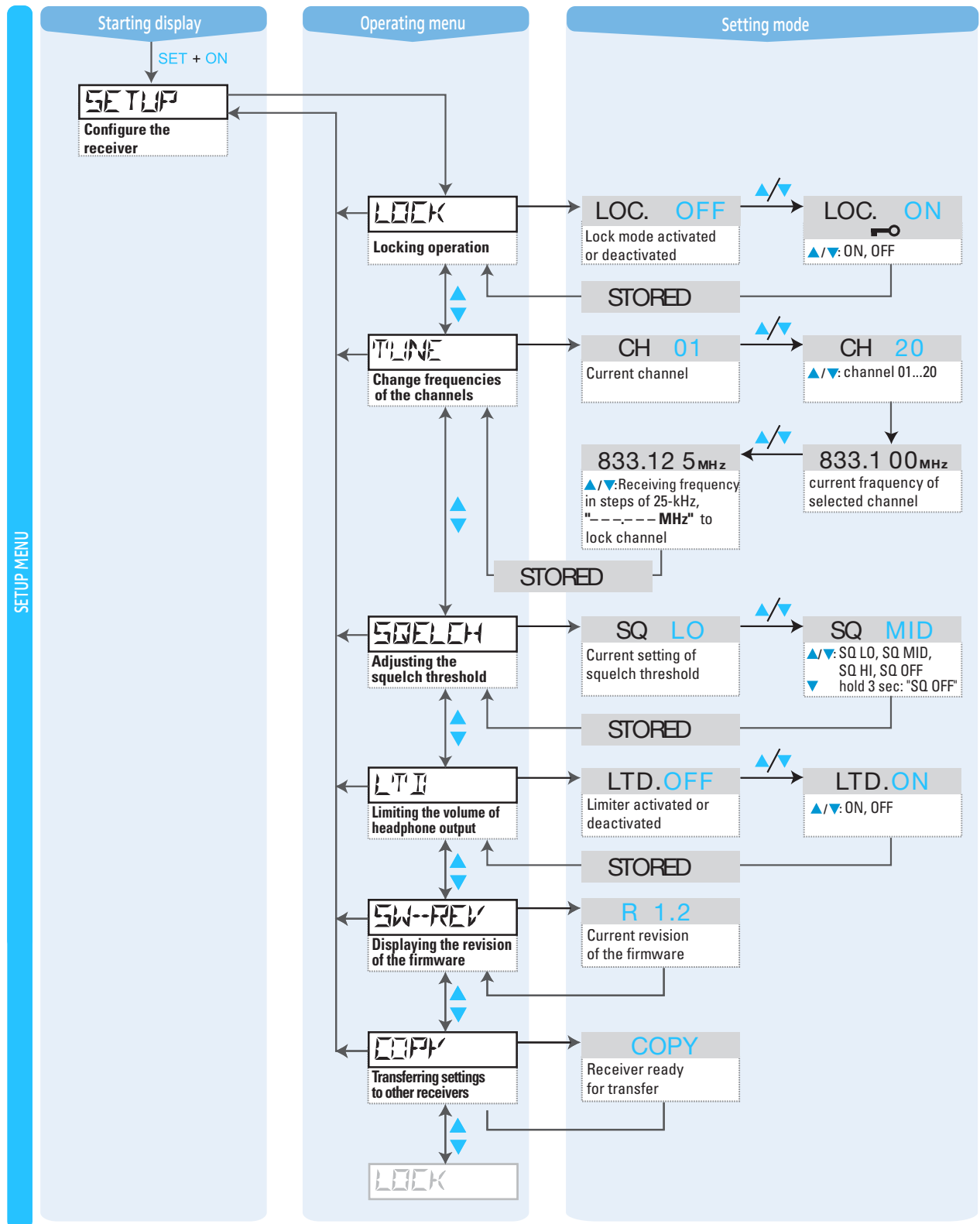

## Adjustment tips for the setup menu

### LOCK

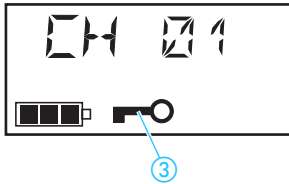

### TUNE

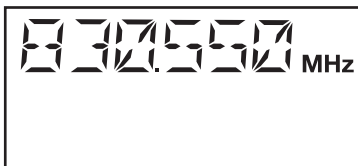
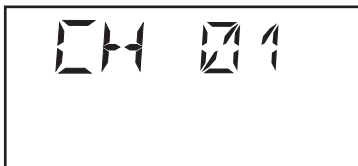

### TUNE

#### Activating/deactivating the lock mode

Via the "LOCK" menu, you can activate or deactivate the lock mode. This mode locks the ▲/▼ rocker button (UP/DOWN) so that the user cannot change the preset channel.

The lock mode icon on the display of the user interface (user menu) indicates that the lock mode is activated.

To deactivate the lock mode you have to select "LOC.OFF" within the menu "LOCK" of the setup menu.

#### Changing the receiving frequencies of the channels

Via the "TUNE" menu you can change the receiving frequency of a channel or you can lock certain channels (see "Locking channels for the user" on page 20).

16 of 20 channels do have factory-preset receiving frequencies. These frequencies do not cause any intermodulation interferences and they ensure a safe and trouble-free reception even if several transmission links are operated simultaneously.

##### Note:

The receiving frequency of the receiver must exactly correspond to the transmission frequency of the transmitter!

- ▶ Select the "TUNE" menu to change these frequencies or to enter the receiving frequencies for the channels 17 to 20. The current channel flashes on the display.
- ▶ Use the ▲/▼ rocker button (UP/DOWN) to select the channel whose frequency you would like to change. The selected channel flashes on the display.
- ▶ Press the SET button to confirm your selection. The current receiving frequency of the selected channel flashes on the display.
- ▶ Use the ▲/▼ rocker button to select the desired receiving frequency. Receiving frequencies are tunable in 25-kHz steps. The selected receiving frequency flashes on the display.
- ▶ Press the SET button to store the new receiving frequency.

#### Locking channels for the user

Via the "TUNE" menu you can lock certain channels so that the user cannot select them. This makes sense when several guided tours take place at the same time and several transmission links are oper-

ated simultaneously. As only the selectable channels are displayed, the user can quickly switch to the channel stated by the guide.

Select the channel you like to lock as described within the chapter “Changing the receiving frequencies of the channels” on page 20 and confirm your selection by pressing the **SET** button.

The current receiving frequency of the selected channel flashes on the display.

- ▶ Use the ▲/▼ rocker button (UP/DOWN) to select the character string “---.---”. This string follows the frequency 866.000 MHz and precedes 830.000 MHz.
- ▶ Press the **SET** button to store your setting.  
This channel is now locked is no longer displayed for the user.

### Releasing locked channels

Via the “TUNE” menu you can release locked channels.

- ▶ Select the channel that you would like to release.
- ▶ Use the ▲/▼ rocker button (UP/DOWN) to select the frequency that you would assign to the channel.
- ▶ Press the **SET** button to store the setting.
- ▶ The user can now select the channel again.

## SQELCH

### Adjusting the squelch threshold

The receiver is equipped with a squelch that can be adjusted via the “SQELCH” menu. The squelch eliminates annoying noise when the transmitter is switched off. It also suppresses sudden noise when there is no longer sufficient transmitter power received by the receiver.

#### Note:

Before adjusting the squelch threshold to a different setting, use the volume control ① to set the volume for the connected headphones to the minimum.

There are three possible squelch settings:

- SQ LO = low
- SQ MID = middle
- SQ HI = high

Selecting the setting “SQ LO” reduces the squelch threshold, selecting the setting “SQ HI” increases the squelch threshold.

- ▶ Adjust the squelch threshold – with the transmitter switched off – to the lowest possible setting that suppresses hissing noise.

**Note:**

- If the squelch threshold is adjusted too high, the transmission range will be reduced. Therefore, always adjust the squelch threshold to the lowest possible setting.
- When in the setting mode of the “**SQELCH**” menu, pressing the ▼ button for more than three seconds will switch the squelch off. “SQ.OFF” flashes on the display. If no RF signal is being received, hissing noise will occur. This setting is for test purposes only.

**LTD****Limiting the volume at the headphone output**

Via the “**LTD**” menu, you can switch the limiter on and off. With the limiter switched on, the maximum possible volume of the headphone output will be reduced about approx. 15 dB.

**Note:**

The receiver is preset so that the limiter is switched on. We recommend to keep the limiter switched on all the time.

**SW-REV****Displaying the revision of the firmware**

Via the “**SW-REV**” menu, you can display the revision of the firmware installed in the device.

The revision displayed is only relevant to the Sennheiser Service department.

**COPY****Copy function****Note:**

If the “**COPY**” menu is not available on your receiver, please contact the Sennheiser Service department.

Via the “**COPY**” menu, you can copy **all** configuration settings of one receiver (master) to an arbitrary number of other receivers (slaves), allowing you to quickly and easily transfer a receiver configuration to other receivers in the system.

To prepare a receiver with “master” function:

- ▶ Select **one** receiver.
- ▶ Set the desired channel and all other receiver settings.
- ▶ Change to the “**COPY**” menu.  
This receiver takes over the “master” function.

To prepare a receiver with “slave” function:

- ▶ Open the battery compartment cover of all receivers to which you want to transfer the settings (slaves).
- ▶ Switch on all receivers.

To copy the settings:

- ▶ Place the receiver with "master" function above the infra-red interface of the other receivers (slaves), one after the other. The distance between the infra-red interfaces 12 of both receivers (master and slave) must not exceed 10 cm.

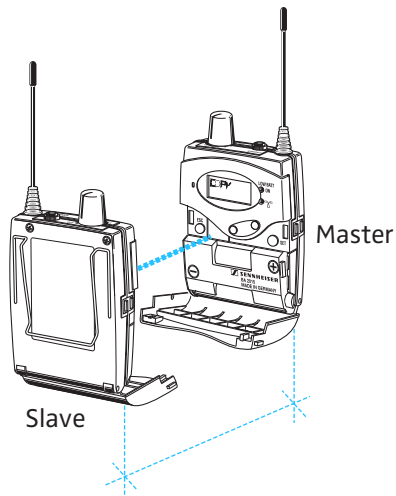

The settings are copied and the text "COPY" briefly appears on the display of the receiver (slave). If data transfer was successful, the receiver (slave) switches off automatically.

**Note:**

Strong extraneous light may interfere with the data transfer via the infra-red interface. Therefore, position the receivers so that any possible interference caused by extraneous light is avoided. The arrow in the diagram on the left indicates the direction from which the IR radiation must impinge upon the receiver.

## L 2015 quick charger

### Special features

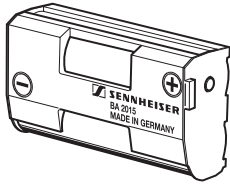

The L 2015 quick charger must only be used for automatically charging BA 2015 battery packs – individual rechargeable battery cells or primary cells **cannot** be charged! The BA 2015 battery pack is delivered as accessory with the EK 1038 receiver and fits to the Sennheiser bodypack receivers ew series G2 as well (see “SK 100 G2 / SK 300 G2 / SK 500 G2 bodypack transmitters” on page 34).

The EK 1038 receiver and the SK bodypack transmitters have charging contacts on their sides and can thus be charged with the accupack inserted in the L 2015 charger. When placed into the charger, the transmitters and receiver automatically switch off.

Features of the charger:

- Quick charge in approx. 2½ hours (with completely discharged accupacks and room temperature).
- Automatic detection of full charge and subsequent switching to trickle charge so the accupacks can remain in the charger even when they have been fully charged.
- Highest possible operational reliability, since correct insertion, temperature and voltage of the accupacks are monitored during charging.
- Up to two accupacks can be charged – optionally separately or inserted in the transmitter or receiver – separately.
- Several chargers can be cascaded together to form a larger charging station which can be powered by a common mains unit (see “Accessories and spare parts” on page 54).

## Operating controls

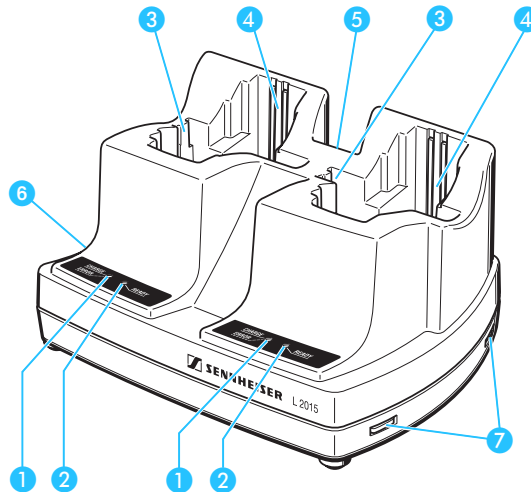

- ① Red LED CHARGE/ERROR (2 x)
- ② Green LED READY (2 x)
- ③ Charging compartment for BA 2015 rechargeable battery (2 x)
- ④ Charging compartment for EK 1038 or bodypack transmitters of the evolution wireless G2 series (2 x)
- ⑤ Air vent
- ⑥ Mains connection
- ⑦ Guiding slot with internal rail (2 x)

### LED indications

Each charging compartment has two LEDs which indicate the following operating states:

<b>No LED lit:</b>	The charging compartment is ready for operation (provided that the charger is connected to the mains), no rechargeable battery is identified.
<b>All LEDs briefly light up one after the other:</b>	The charger has been connected to the mains and is carrying out a self test.
<b>Red LED ① lit:</b>	The rechargeable battery is being charged.
<b>Red LED ① flashing:</b>	A problem has occurred (see "Troubleshooting" on page 51).
<b>Green LED ② lit:</b>	The rechargeable battery is fully charged and the charger has switched to trickle charging.

## Preparing for use

### Cascading several chargers

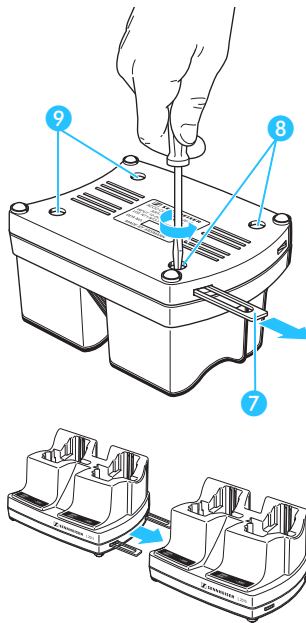

- ▶ Make sure that the charger is disconnected from the mains.
- ▶ Unscrew the two screws 8 at the right bottom side of the charger.
- ▶ Slide the two rails 7 out of the guiding slots and screw them tight using the two screws 8.
- ▶ Unscrew the two screws 9 at the left bottom side of the second charger.
- ▶ Slide the second charger onto the rails of the first charger and screw the rails tight using the two screws 9.
- ▶ Up to three chargers can be cascaded together with the rails and can be powered by a common mains unit..

#### Numbers of chargers Mains unit required

1	NT 1
up to 3	NT 3

### Setting up the charger

The charger has four plastic feet to ensure that it cannot slip on the surface on which it is placed.

#### CAUTION! Risk of staining of furniture surfaces!



Some furniture surfaces have been treated with varnish, polish or synthetics which might cause stains when they come into contact with other synthetics. Despite a thorough testing of the synthetics used by us, we cannot rule out the possibility of staining.

- ▶ Do not place the receiver on delicate surfaces.

### Switching the charger on or off

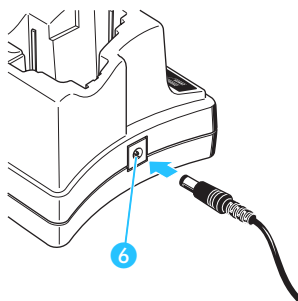

- ▶ To switch the charger on, insert the hollow jack plug on the cable of the mains unit (mains unit must be ordered separately) into socket 6.
- ▶ Connect the mains unit to the mains.  
All LEDs briefly light up one after the other.



## Using the charger

### Charging the rechargeable battery BA 2015

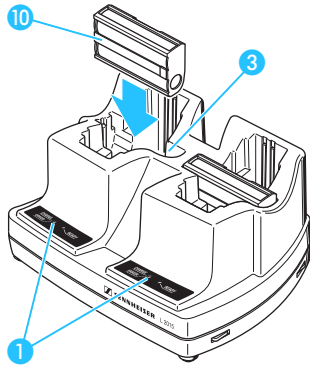

- ▶ Insert the rechargeable battery 10 into one of the two charging compartments 3 as shown.

The red LED 1 at the occupied charging compartment lights up.

Charging a completely discharged rechargeable battery takes approx. 2½ hours at room temperature. It is normal for the accupacks to get warm during charging.

However, the charging process may take longer if:

- the rechargeable battery is deep-discharged and first has to be reconditioned by a deep discharge recovery charge,
- the ambient temperature is close to or over 40 °C, since, in order to protect the accupack, the charging process will be interrupted until the rechargeable battery temperature has fallen to an admissible value.

For safety reasons, the charging process will be interrupted and the red LED 1 will start flashing if:

- excessively hot accupacks cannot cool down,
- an rechargeable battery cannot be fully charged within the max. charging time of 6 hours, e.g. due to overaged cells.

- ▶ After the rechargeable battery has been fully charged, the green LED 2 lights up.

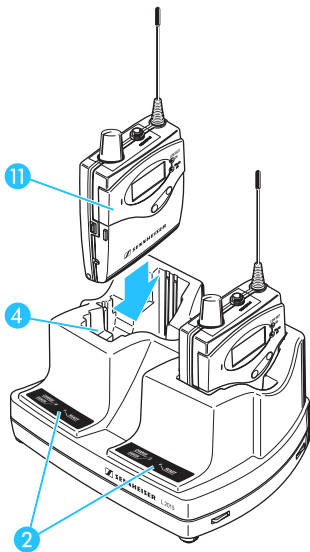

#### Note:

For charging, the accupacks can remain in the unit. Place the unit 11 with the rechargeable battery inserted into the charging compartment 4 as shown. The receiver or the transmitter automatically switch off.

## Care and maintenance

Use a slightly damp cloth to clean the switched-off charger from time to time. Use a brush or similar to remove dust from the charging compartments. Do not use any cleansing agents or solvents.

## Suitable transmitters of the evolution wireless series G 2



The EK 1038 bodypack receiver matches any of the transmitters (range E) of the Sennheiser evolution wireless series G 2:

- Radiomicrophones: SKM 100 G2 / SKM 300 G2 / SKM 500 G2
- Bodypack transmitters: SK 100 G2 / SK 300 G2 / SK 500 G2
- Plug-on transmitters: SKP 100 G2 / SKP 500 G2

The SK 2015 bodypack transmitter of the 2015 system from the domain of audiology also fits to the EK 1038 bodypack receiver.

### Note:

To put the system into operation, transmitter and receiver must be set to the same frequency!

## The channel bank system

The system is available in the UHF frequency range from 830 to 866 MHz with 1440 transmission frequencies. Transmitters that are to be combined with the EK 1038 bodypack receiver thus have to use the following transmission range:

Range E: 830 to 866 MHz

The transmitters have nine channel banks with up to 20 channels each.

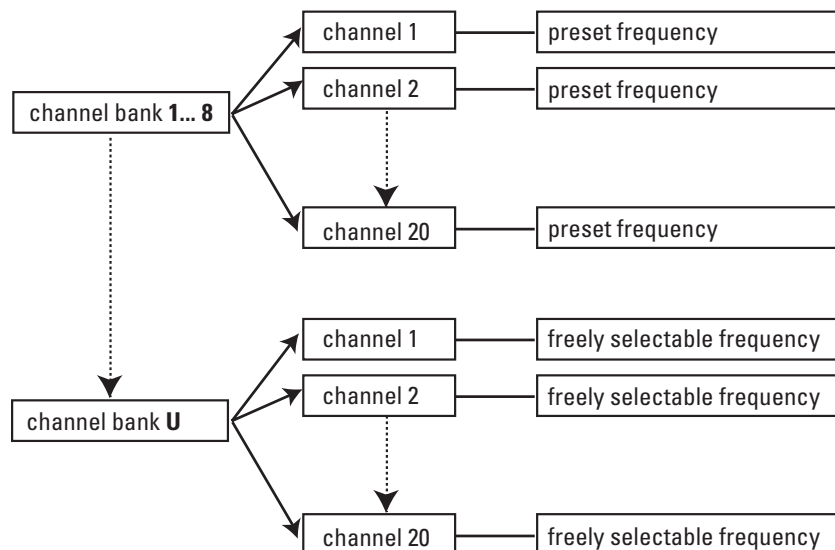

Each of the channels in the channel banks "1" to "8" has been factory-preset to a transmission frequency (see enclosed frequency table). These transmission frequencies cannot be changed but have

been preset so that e.g. country-specific regulations on frequency usage are taken into account.

The channel bank "U" (user bank) allows you to store your selection out of 1440 transmission frequencies that are freely selectable within the preset frequency range.

**Note:**

The tourguide frequencies are preset on the channel bank "8".

# SKM 100 G2 / SKM 300 G2 / SKM 500 G2 radiomicrophones

## Delivery includes

The packaging contains the following items:

- 1 radiomicrophone
- 2 batteries
- 1 microphone clamp
- 1 pouch

## Operating Controls

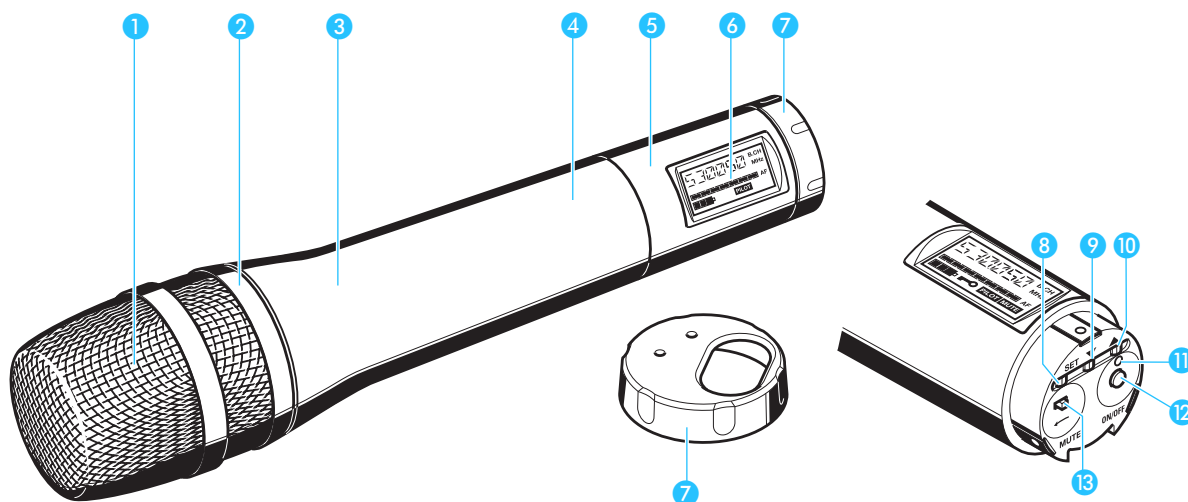

- ① Sound inlet basket
- ② Color-coded identification ring for microphone heads
  - green: MD 835 microphone head
  - blue: MD 845 microphone head
  - red: ME 865 microphone head
- ③ Body of radiomicrophone
- ④ Battery compartment (not visible from outside)
- ⑤ Display section
- ⑥ LC display
- ⑦ Turnable protective cap for operating controls (shown removed)  
The following operating controls become accessible in turn by turning the protective cap:
  - ⑧ SET button
  - ⑨ ▼ button (DOWN)
  - ⑩ ▲ button (UP)
  - ⑪ Red LED for operation and battery status indication (ON/LOW BAT)
  - ⑫ ON/OFF button
  - ⑬ MUTE switch

## Preparing for use

### Inserting and changing the battery

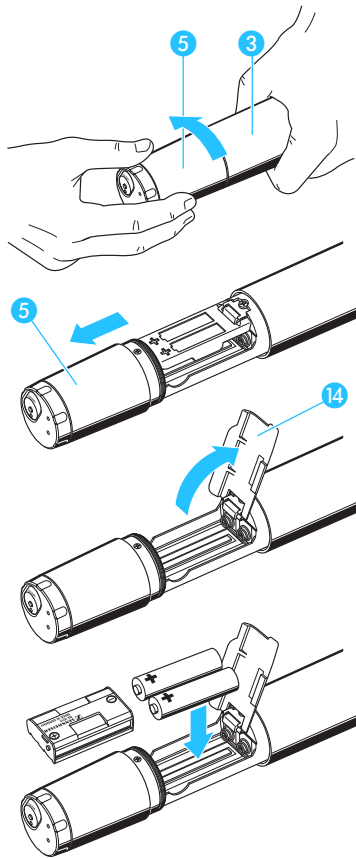

For powering the radiomicrophone, you can either use two 1.5 V AA size batteries or the rechargeable Sennheiser BA 2015 battery pack.

- ▶ Unscrew the display section 5 from the radiomicrophone's body 3 by turning it counter-clockwise.
- ▶ Slide back the display section 5 as far as it will go.
- ▶ Open the battery compartment 14.
- ▶ Insert the 9 V PP3 alkaline battery (IEC 6 LR 61) or the BA 2015 accupack. Please observe correct polarity when inserting the battery.
- ▶ Close the battery compartment cover 14.
- ▶ Push the battery compartment into the radiomicrophone's body.
- ▶ Screw the display section tight.

#### Note:

For rechargeable battery operation of the receiver, only use the BA 2015 rechargeable battery. In order to ensure optimum operational reliability. For charging the accupack, only use the L 2015 charger. Both the rechargeable battery and the charger are available as accessories. The rechargeable battery is fitted with an integrated sensor which is – via a third contact – monitored by the electronics of the receiver and the charger. The sensor is necessary for the following control purposes:

- The taking into account of the different voltage characteristics of primary cells (batteries) and accupacks. The battery status indications on the displays, the transmission of transmitter battery status information to the rack-mount receivers and the switch-off thresholds at the end of the operating time are corrected correspondingly. Due to the missing sensor, individual rechargeable battery cells will not be identified as accupacks.
- The monitoring of the rechargeable battery temperature during charging in the L 2015 charger.

### Changing the microphone module

- ▶ First remove the battery or the rechargeable battery and leave the radiomicrophone open.
- ▶ Unscrew the sound inlet basket.

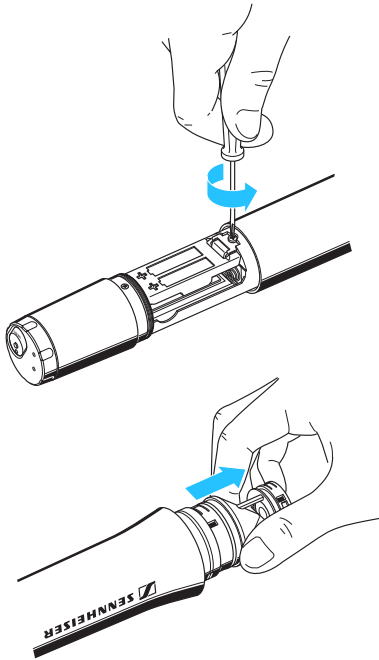

- ▶ Remove the screw and put it to one side.
- ▶ Remove the microphone module by pulling it out of the housing as shown. Do not touch the contacts!
- ▶ Insert the new module.
- ▶ Secure the capsule by tightening the screw.

**Note:**

The screw mechanically secures the microphone capsule. If the screw is missing, malfunctions may occur during tough use.

- ▶ Put on the sound inlet basket and identification ring supplied with the new microphone head and screw it tight.
- ▶ Insert the batteries/accupack.
- ▶ Close the radiomicrophone and put it into operation.

**Note:**

Microphone capsule, sound inlet basket and foam insert form an acoustic unit and must therefore always be exchanged all together. Each microphone head comes with a color-coded identification ring to distinguish different microphone heads from each other (green = MD 835, blue = MD 845, red = ME 865).

## Using the radiomicrophone

### Switching the radiomicrophone on/off

The radiomicrophone can only be switched off when the standard display is shown on the display panel. When in the operating menu, briefly pressing the **ON/OFF** button will cancel your entry (ESC function) and return you to the standard display with the last stored settings.

**Note:**

Remove the batteries or the rechargeable battery when the radiomicrophone will not be used for extended periods of time.

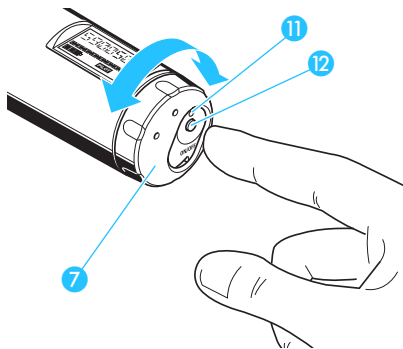

- ▶ Turn the protective cap **7** at the bottom of the radiomicrophone so that the **ON/OFF** button **12** becomes accessible.
- ▶ Press the **ON/OFF** button to switch the radiomicrophone on. The red LED **11** lights up.
- ▶ To switch the radiomicrophone off, press the **ON/OFF** button **12** until "OFF" appears on the display. The red LED **11** goes off.

## Muting the radiomicrophone

The radiomicrophone has a **MUTE** switch that noiselessly mutes the audio signal without switching the radiomicrophone off.

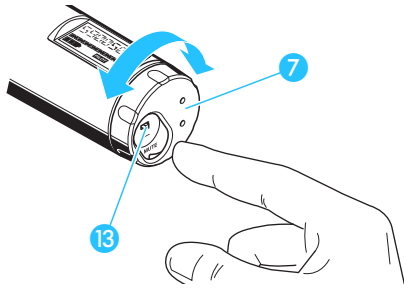

- ▶ Turn the protective cap **7** at the bottom of the radiomicrophone so that the **MUTE** switch **13** becomes accessible.
- ▶ Set the **MUTE** switch to the position 'MUTE'. The "MUTE" display appears on the radiomicrophone's display panel.
- ▶ Set the **MUTE** **13** switch back to the original position to retransmit the audio signal.

## Operation and battery status indication

The red LED (LOW BAT/ON) **11** provides information on the current operating state of the radiomicrophone:

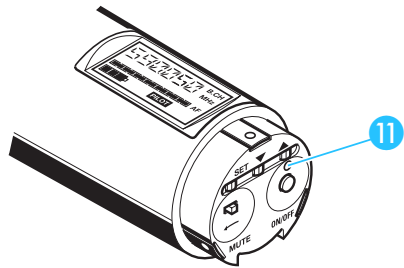

Red LED lit up: The radiomicrophone is switched on and the capacity of the batteries/BA 2015 rechargeable battery is sufficient.

Red LED flashing: The batteries are/the BA 2015 rechargeable battery is going flat (LOW BAT)!

## Care and maintenance

Use a slightly damp cloth to clean the radiomicrophone from time to time.

### Note:

Do not use any cleansing agents or solvents.

To clean the radiomicrophone's sound inlet basket, proceed as follows:

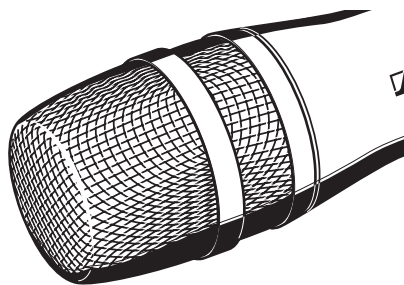

- ▶ Unscrew the sound inlet basket (turn counterclockwise) and remove it.
- ▶ Remove the foam insert.
- ▶ Use a slightly damp cloth to clean the sound inlet basket from the inside and outside.
- ▶ Reinsert the foam insert.
- ▶ Replace the sound inlet basket on the radiomicrophone and screw it tight.

# SK 100 G2 / SK 300 G2 / SK 500 G2 bodypack transmitters

## Delivery includes

The packaging contains the following items:

- 1 bodypack transmitter
- 2 batteries
- 1 BPP 1 bodypack pouch
- 1 clip-on microphone (please specify when ordering)

## Operating Controls

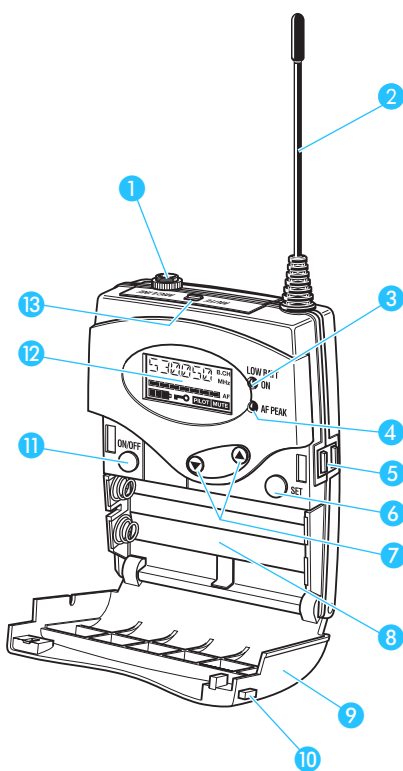

- 1 Microphone/line input (MIC/LINE), 3.5 mm jack socket
- 2 Antenna
- 3 Red LED for operation and battery status indication (ON/LOW BAT)
- 4 Yellow LED for audio peak (AF PEAK)
- 5 Charging contacts
- 6 SET button
- 7 ▼/▲ rocker button (UP/DOWN)
- 8 Battery compartment
- 9 Battery compartment cover
- 10 Unlocking button
- 11 ON/OFF button (serves as ESC (cancel) key in the operating menu)
- 12 LC display
- 13 MUTE switch

## Preparing for use

### Inserting and changing the battery

For powering the transmitter, two 1.5 V AA size batteries are required.



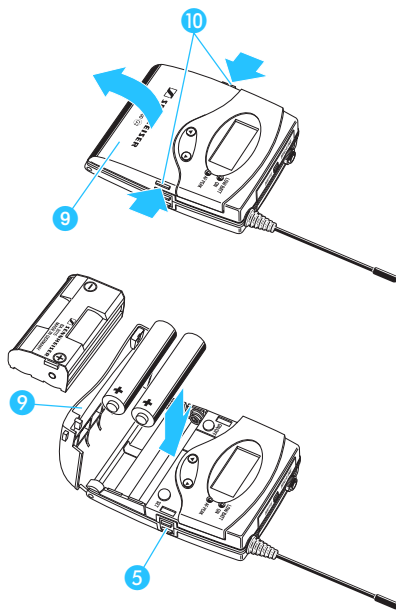

- ▶ Press the two unlocking buttons 10 and open the battery compartment cover 9.
- ▶ Insert the two batteries as shown above. Please observe correct polarity when inserting the batteries.
- ▶ Close the battery compartment. The battery compartment cover 9 locks into place with an audible click.

### Inserting and charging the accupack

The transmitter can also be powered via the rechargeable Sennheiser BA 2015 accupack. Insert the rechargeable battery into the battery compartment as described above.

The transmitter has two charging contacts 5 and a sensing contact on its short sides. The rechargeable battery can be recharged while remaining in the transmitter. Insert the transmitter into the L 2015 charger (see "Charging the rechargeable battery BA 2015" on page 27).

#### Note:

For rechargeable battery operation of the transmitter, only use the BA 2015 rechargeable battery in order to ensure optimum operational reliability. For charging the accupack, only use the L 2015 charger. Both the rechargeable battery and the charger are available as accessories.

The rechargeable battery is fitted with an integrated sensor which is – via a third contact – monitored by the electronics of the transmitter and the charger. The sensor is necessary for the following control purposes:

- The taking into account of the different voltage characteristics of primary cells (batteries) and accupacks. The battery status indications on the displays, the transmission of transmitter battery status information to the rack-mount receivers and the switch-off thresholds at the end of the operating time are corrected correspondingly. Due to the missing sensor, individual rechargeable battery cells will not be identified as accupacks.
- The monitoring of the rechargeable battery temperature during charging in the L 2015 charger.

- The prevention of improper charging of inserted primary cells (batteries). Due to the missing sensor, individual rechargeable battery cells will also not be charged in the L 2015 charger.

### Connecting the microphone/line cable

The microphone/line input is designed for the connection of both condenser microphones and instruments (e.g. guitars). DC powering of the condenser microphones is via the microphone/line input.

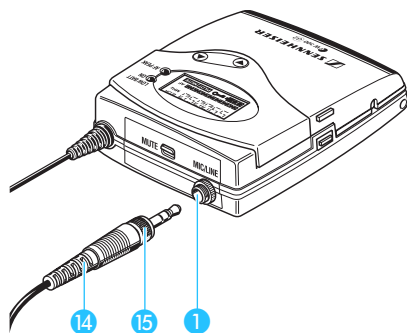

- ▶ Connect the 3.5 mm jack plug 14 from the microphone/line cable to the 3.5 mm jack socket (MIC/LINE) 1.
- ▶ Lock the 3.5 mm jack plug by screwing down the coupling ring 15.
- ▶ Via the operating menu, adjust the sensitivity of the microphone/line input (MIC/LINE).

### Attaching the microphones

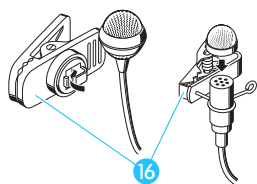

- ▶ Use the microphone clips 16 to attach the ME 2 or ME 4 clip-on microphones to clothing (e.g. tie, lapel).
- ▶ Adjust the ME 3 headmic so that a comfortable and secure fit is ensured.

### Positioning the microphones

The ME 3 and ME 4 microphones are directional microphones, i.e. their sound inlet should always be directed towards the sound source (e.g. mouth).

The ME 2 with omni-directional pick-up pattern picks up sound equally from all directions. It is the best choice if movements of the speaker's head have to be compensated for. However, it should be attached as close as possible to the sound source.

Adjust the sensitivity correctly for all microphones/usages (see "Adjusting the sensitivity" on page 47).

### Attaching the transmitter to clothing

The transmitter is attached to clothing (e.g. belt, waistband) with the supplied belt clip.

The clip is detachable so that you can also attach the transmitter with the antenna pointing downwards. To do so, withdraw the clip from its fixing points and attach it the other way round.

The supplied BPP 1 bodypack pouch helps to protect the transmitter against moisture.

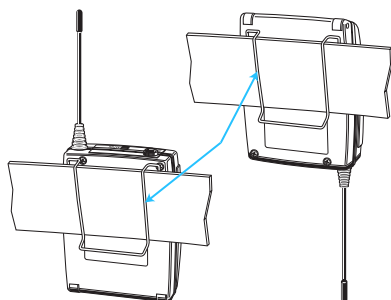
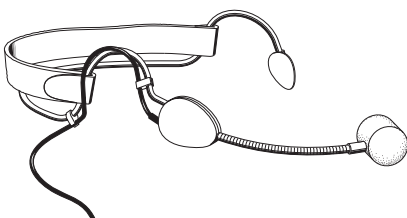

## Using the bodypack transmitter

### Switching the transmitter on/off

The transmitter can only be switched off when the standard display is shown on the display panel. When in the operating menu, briefly pressing the **ON/OFF** button will cancel your entry (ESC function) and return you to the standard display with the last stored settings.

#### Note:

Remove the batteries or the rechargeable battery when the transmitter will not be used for extended periods of time.

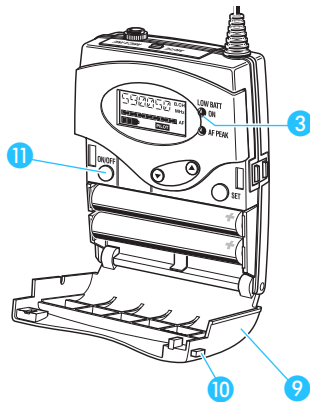

- ▶ Press the two unlocking buttons **10** and open the battery compartment cover **9**.
- ▶ Press the **ON/OFF** button **11** to switch the transmitter on. The red LED **3** lights up.
- ▶ To switch the transmitter off, press the **ON/OFF** button **11** until "OFF" appears on the display. The red LED **3** goes off.
- ▶ Close the battery compartment. The battery compartment cover **9** locks into place with an audible click.

### Muting the transmitter

The transmitter has a **MUTE** switch that noiselessly mutes the transmitter's audio signal without switching the transmitter off.

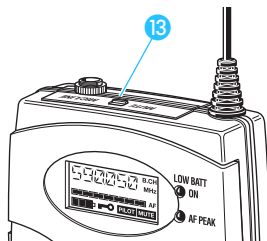

- ▶ Set the **MUTE** switch **12** to the position 'MUTE'. The "MUTE" display appears on the display panel.
- ▶ Set the **MUTE** switch **13** back to the original position to retransmit the audio signal.

### Operation and battery status indication

The red LED (LOW BAT/ON) **3** provides information on the current operating state of the transmitter:

Red LED lit up: The transmitter is switched on and the capacity of the batteries/BA 2015 rechargeable battery is sufficient.

Red LED flashing: The batteries are/the BA 2015 rechargeable battery is going flat (LOW BAT)!

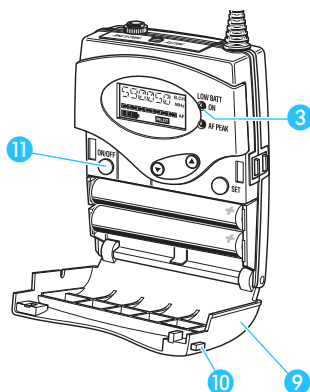

# SKP 100 G2 / SKP 500 G2 plug-on transmitters

## Delivery includes

The packaging contains the following items:

- 1 plug-on transmitter
- 2 batteries
- 1 POP 1 plug-on pouch

Suitable microphones (to be ordered separately) for the plug-on transmitter:

- Dynamic microphones
- Condenser microphones with internal power supply
- Condenser microphones with 48 V phantom powering

## Operating Controls

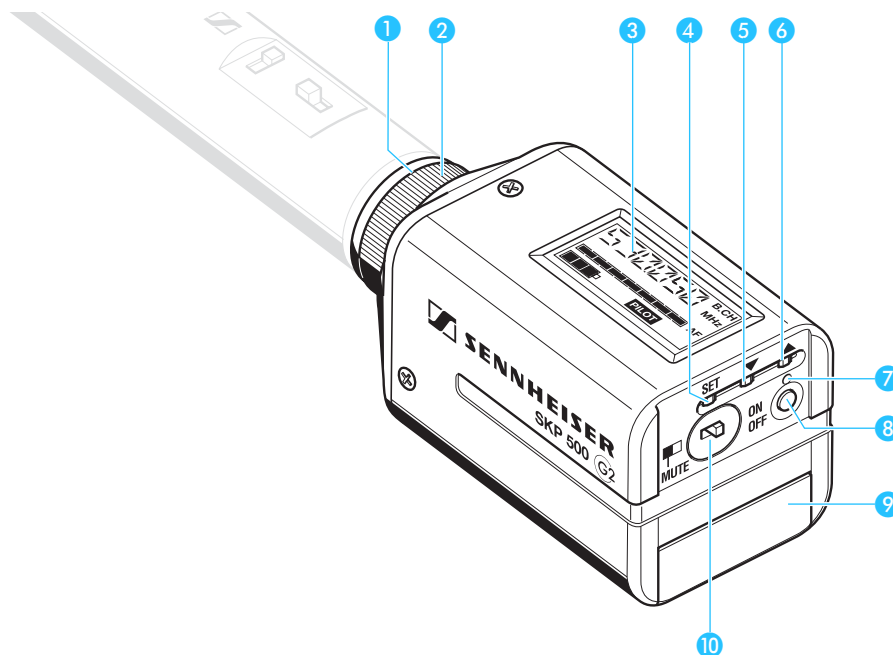

- |  |   |
|--|---|
| 1 Microphone input, XLR-3 socket, (unbalanced) | 6 ▲ button (UP)                                       |
| 2 Mechanical locking ring of XLR-3 socket      | 7 Red LED for operation and battery status indication |
| 3 LC display                                   | 8 ON/OFF button                                       |
| 4 SET button                                   | 9 Battery compartment cover                           |
| 5 ▼ button (DOWN)                              | 10 MUTE switch  |

## Preparing for use

### Inserting and changing the battery

For powering the plug-on transmitter, you can either use two 1.5 V AA size batteries or the rechargeable Sennheiser BA 2015 accupack.

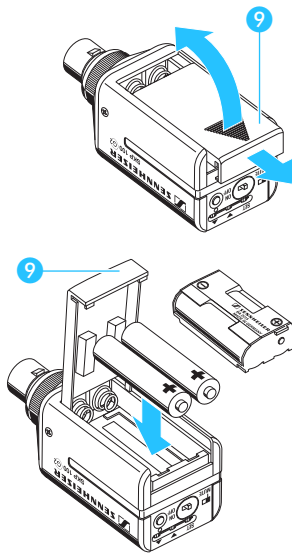

- ▶ Slide the battery compartment cover **9** in the direction of the embossed arrow until it clicks audibly and open the cover.

- ▶ Insert the two batteries or the BA 2015 rechargeable battery as shown below. Please observe correct polarity when inserting the batteries/accupack.

- ▶ Close the battery compartment. The battery compartment cover **9** locks into place with an audible click.

#### Note:

For rechargeable battery operation of the transmitter, only use the BA 2015 rechargeable battery in order to ensure optimum operational reliability. For charging the accupack, only use the L 2015 charger. Both the rechargeable battery and the charger are available as accessories.

The rechargeable battery is fitted with an integrated sensor which is – via a third contact – monitored by the electronics of the plug-on transmitter and the charger. The sensor is necessary for the following control purposes:

- The taking into account of the different voltage characteristics of primary cells (batteries) and accupacks. The battery status indications on the displays, the transmission of transmitter battery status information to the rack-mount receivers and the switch-off thresholds at the end of the operating time are corrected correspondingly. Due to the missing sensor, individual rechargeable battery cells will not be identified as accupacks.
- The monitoring of the rechargeable battery temperature during charging in the L 2015 charger.

### Plugging the transmitter onto the microphone

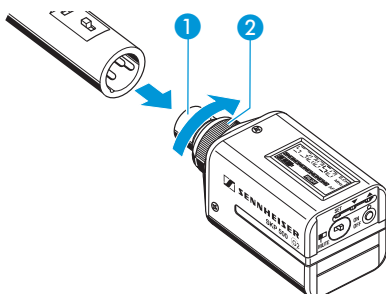

- ▶ Plug the transmitter's XLR-3 connector **1** onto the microphone's XLR-3 socket.
- ▶ Tighten the locking ring **2**.

#### Note:

The transmitter uses the microphone body as an antenna – therefore only microphones with a metal casing should be used for best signal transmission.

### Betriebs- und Batterieanzeige

The red LED (LOW BAT/ON) ⑦ provides information on the current operating state of the plug-on transmitter:

Red LED lit up: The plug-on transmitter is switched on and the capacity of the batteries/BA 2015 rechargeable battery is sufficient.

Red LED flashing: The batteries are/the BA 2015 rechargeable battery is going flat (LOW BAT)!

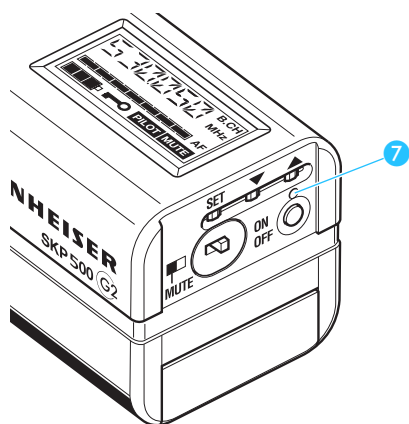

## LC display panel of the evolution wireless transmitters G 2

### LC display panel

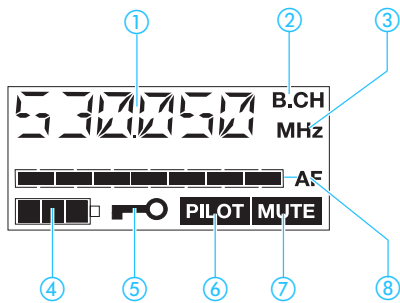

- ① Alphanumeric display
- ② "B.CH" – appears when the channel bank and the channel number are displayed
- ③ "MHz" – appears when the frequency is displayed
- ④ 4-step battery status display
- ⑤ Lock mode icon (lock mode is activated)
- ⑥ "PILOT" display (pilot tone transmission is activated)
- ⑦ "MUTE" display (audio input is muted)
- ⑧ 7-step level display for audio signal "AF"

### Battery status indication

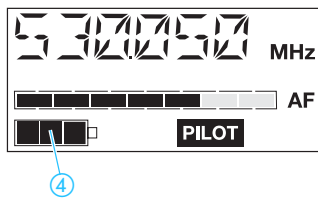

The 4-step battery status display ④ on the display panel provides information on the remaining battery/BA 2015 rechargeable battery capacity:

3 segments:	capacity approx. 100 %
2 segments:	capacity approx. 70 %
1 segment:	capacity approx. 30 %

Battery icon flashing: LOW BAT

### "MUTE" display

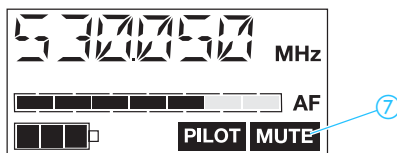

The "MUTE" display ⑦ appears on the display panel when the plug-on transmitter is muted.

### Modulation display

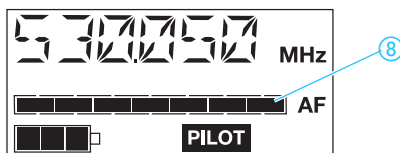

The level display for audio signal "AF" ⑧ shows the modulation of the plug-on transmitter.

When the audio input level is excessively high, the level display for audio signal "AF" ⑧ shows full deflection for the duration of the overmodulation.

### "PILOT" display

The "PILOT" display ⑥ appears on the display panel when the pilot tone transmission is activated.

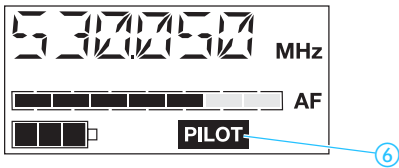

### Display backlighting

After pressing a button, the display remains backlit for approx. 15 seconds.



## The operating menu of the transmitters evolution wireless series G 2

With the exception of one transmitter, the operating menu of the transmitters of the evolution wireless G2 series is equal for all transmitters.

### Overview of menus

Display	Function of the menu
<b>BANK</b>	Switching between channel banks
<b>CHAN</b>	Switching between the channels in a channel bank
<b>TUNE</b>	Setting a transmission frequency for the channel bank "U" (user bank)
<b>SENSIT</b>	Adjusting the sensitivity (AF)
<b>DISPLY</b>	Selecting the standard display
<b>NAME</b>	Entering a name
<b>RESET</b>	Loading the factory-preset default settings
<b>PILOT</b>	Activating/deactivating the pilot tone transmission
<b>LOCK</b>	Activating/deactivating the lock mode
<b>EXIT</b>	Exiting the operating menu and returning to the standard display

### The buttons

Buttons	Mode	To...
<b>ON</b>	Standard display	switch the transmitter on and off
	Operating menu	cancel the entry and return to the standard display
	Setting mode	cancel the entry and return to the standard display
<b>SET</b>	Standard display	get into the operating menu
	Operating menu	get into the setting mode of the selected menu
	Setting mode	store the settings and return to the top menu level
<b>▲/▼</b>	Standard display	without function
	Operating menu	change to the previous menu (▲) or change to the next menu (▼)
	Setting mode	adjust the setting of the selected menu: option (▲/▼)

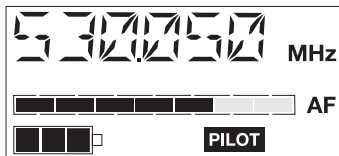

## Working with the operating menu

By way of example of the "TUNE" menu, this section describes how to use the operating menu.

After switching the transmitter on, the standard display is shown on the display panel.

### Getting into the operating menu

- ▶ Press the **SET** button to get from the standard display into the operating menu. The last selected menu flashes on the display.

### Selecting a menu

- ▶ Press the **▲/▼** buttons to select the menu you would like to adjust the setting.
- ▶ Press the **SET** button to get into the setting mode of the selected menu. The current setting that can be adjusted flashes on the display.

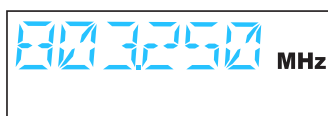

### Adjusting a setting

- ▶ Press the **▲/▼** buttons to adjust the setting.
- ▶ By briefly pressing the **▲/▼** buttons, the display jumps either forwards or backwards to the next setting. In the "CHAN", "TUNE" and "NAME" menu, the **▲/▼** buttons feature a "fast search" function. If you hold down a button, the display cycles continuously, allowing you to get fast and easily to your desired setting.

### Storing a setting

- ▶ Press the **SET** button to store the setting. "STORED" appears on the display, indicating that the setting has been stored. The display then returns to the top menu level.
- ▶ With most menus, new settings become effective immediately without having to be stored. An exception are the "BANK", "CHAN", "TUNE" and "RESET" menus. With these menus, new settings only become effective after they have been stored ("STORED" appears on the display, indicating that the setting has been stored).

### Exiting the operating menu

- ▶ Select the "EXIT" menu to exit the operating menu and to return to the standard display.
- ▶ When in the operating menu, briefly pressing the **ON/OFF** button will cancel your entry (ESC function) and return you to the standard display with the last stored settings.



### Overview of the operating menu of the transmitters

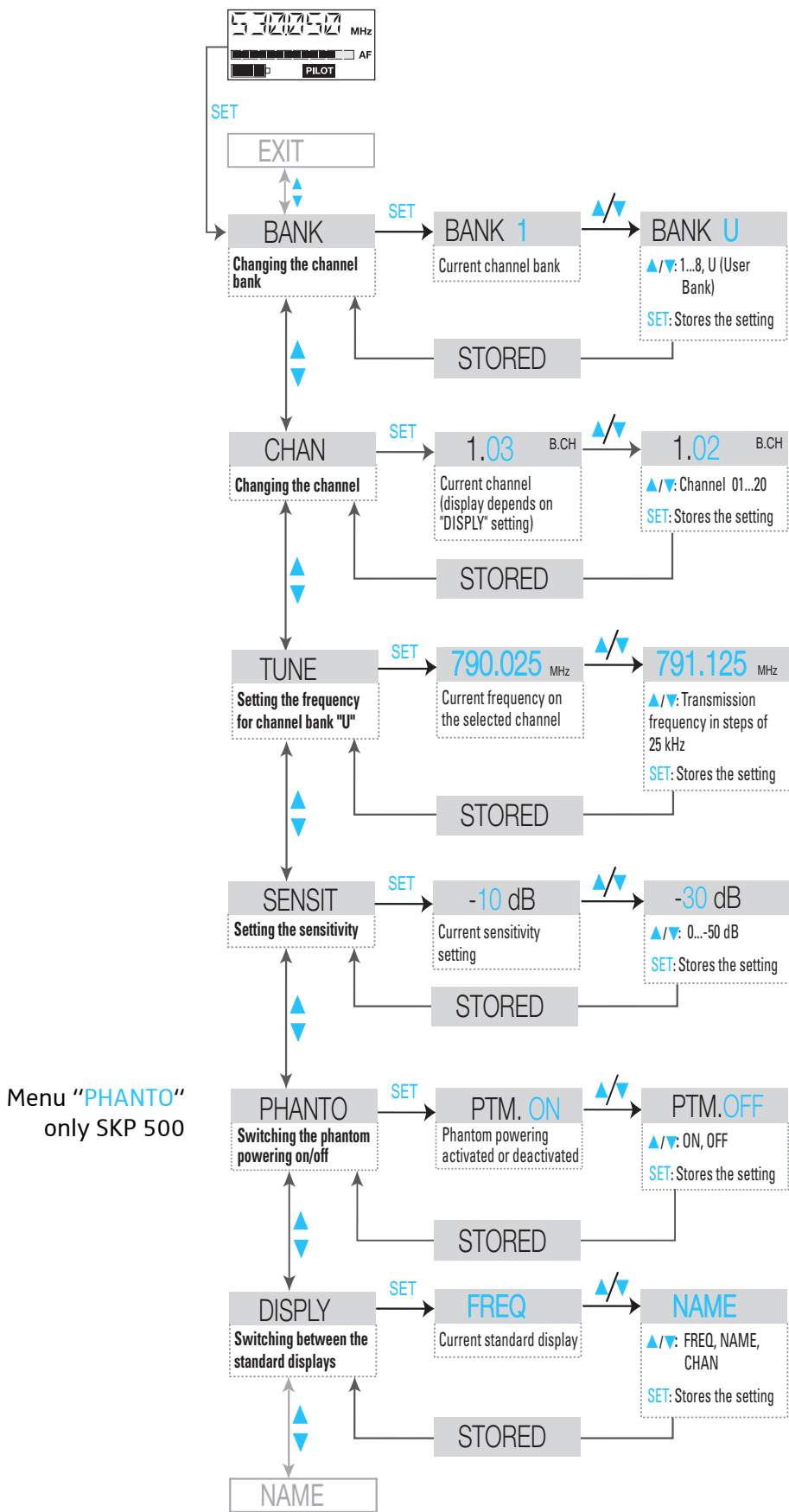

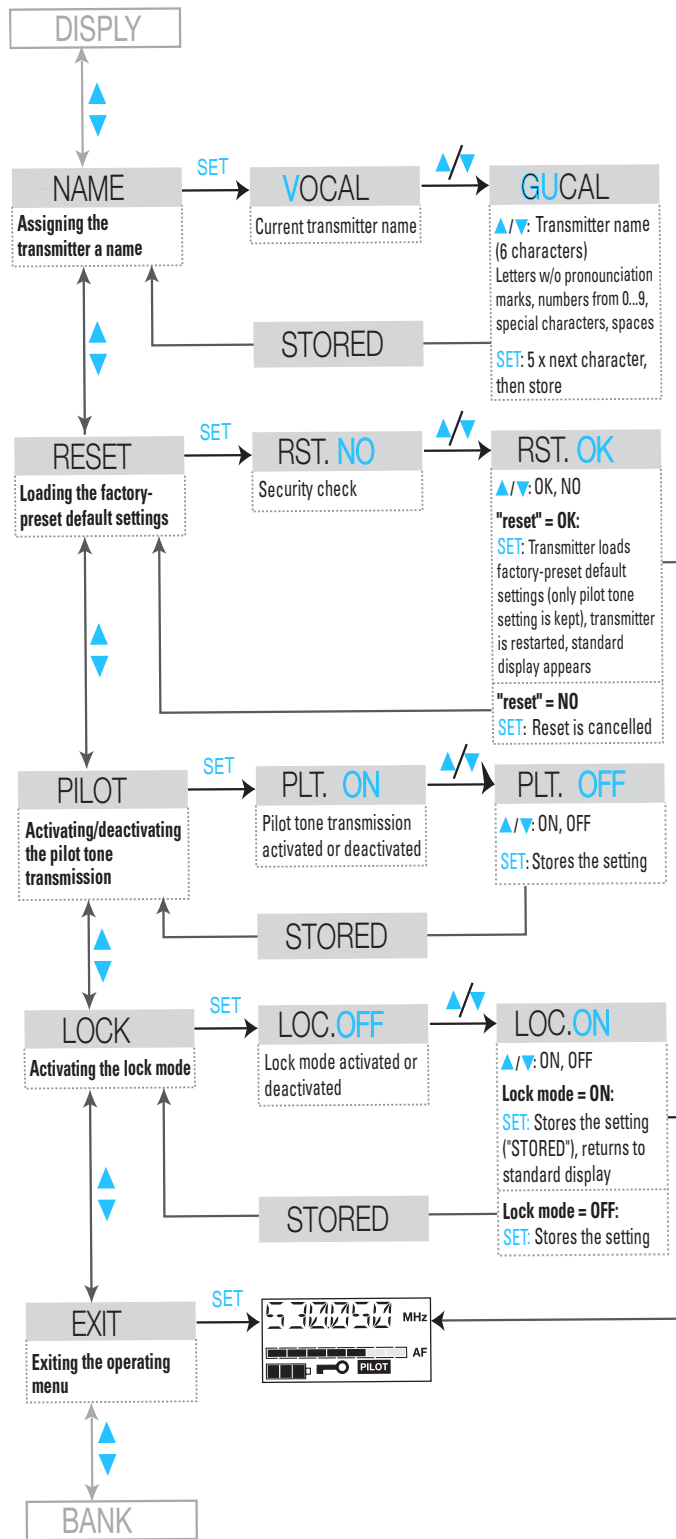

## Adjustment tips for the operating menu

### BANK

#### Switching between channel banks

Via the "BANK" menu, you can switch between the transmitter's nine channel banks. Each of the channel banks "1" to "8" has up to 20 switchable channels that are factory-preset to a transmission frequency. The channel bank "U" (user bank) has up to 20 switchable channels to store your selection out of 1440 transmission frequencies that are freely selectable within the preset frequency range.

When switching from one channel bank to another, the channel with the lowest channel number is automatically displayed.

#### Note:

When using the transmitter with the tourguide system, the channel bank "8" must be selected.

### CHAN

#### Switching between the channels in a channel bank

Via the "CHAN" menu, you can switch between the different channels in a channel bank.

### TUNE

#### Selecting the frequencies to be stored in the channel bank "U"

Via the "TUNE" menu, you can select the frequencies to be stored in the channel bank "U" (user bank).

When you have selected one of the channel banks "1" to "8" and then select the "TUNE" menu, the transmitter automatically switches to channel 01 of the channel bank "U".

In this case, "U.01" briefly appears on the display.

- ▶ Use the ▲/▼ buttons to select the desired transmission frequency. Transmission frequencies are tunable in 25-kHz steps within a switching bandwidth of 36 MHz max. For intermodulation-free frequencies, please refer to the enclosed frequency table.



### SENSIT

#### Adjusting the sensitivity

Via the "SENSIT" menu, you can adjust the transmitter's input sensitivity.

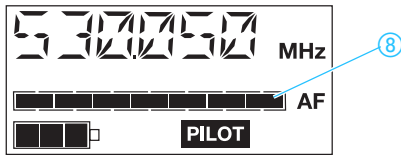

The input sensitivity is adjusted too high when close talking distances, speakers with loud voices or loud music passages cause overmodulation in the transmission link. When the audio input level is excessively high (AF peak), the level display for audio signal (AF) ⑧ shows full deflection.

If, on the other hand, the sensitivity is adjusted too low, the transmission link will be undermodulated, which would result in a signal with high background noise.

The sensitivity is correctly adjusted when the level display for audio signal "AF" ⑧ shows full deflection only during the loudest passages.

#### Note:

For monitoring the adjusted sensitivity, the transmitter's level display for audio signal "AF" always indicates the audio level – even if the transmitter is muted.

The following figures are a guide to the best settings:

- Loud music/vocals: –30 to –20 dB
- Presentations: –20 to –10 dB
- Interviews: –10 to 0 dB

In order to be able to use highly sensitive directional condenser microphones, the plug-on transmitter offers a sensitivity range extended by 20 dB.

With the transmitter plugged onto a directional condenser microphone, the following figures are a guide to the best settings:

- Loud music/vocals: –50 to –40 dB
- Presentations: –40 to –30 dB
- Interviews: –30 to –20 dB

## PHANTO

### Switching the phantom powering on/off (SKP 500 G2 only)

The plug-on transmitter can supply condenser microphones without internal power supply with 48 V phantom powering (P 48). The phantom powering can be switched on or off via the "PHANTO" menu. Please note: Dynamic microphones can be operated in phantom powering mode without harm. However, if no condenser microphone module is being used, you should switch off the phantom powering. With the phantom powering switched on, the operating time of the batteries or the BA 2015 rechargeable battery will be reduced.

**DISPLY****Selecting the standard display**

Via the “DISPLY” menu, you can select the standard display:

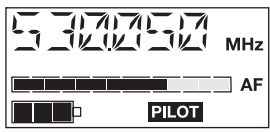
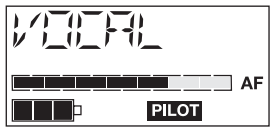
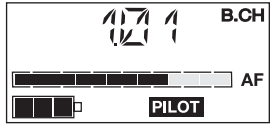
Selectable standard display	Contents of standard display
“FREQ”	
“NAME”	
“CHAN”	

**NAME****Entering a name**

Via the “NAME” menu, you can enter a freely selectable name for the transmitter. The name can be displayed on the standard display and can consist of up to six characters such as:

- letters (without pronunciation marks),
- numbers from 0 to 9,
- special characters e.g. () - . \_ and spaces.

To enter a name, proceed as follows:

After you have entered into the setting mode of the menu, the first segment starts flashing on the display.

- ▶ With the ▲/▼ buttons you can now select a character. By briefly pressing a button, the display jumps either forwards or backwards to the next character. If you hold down a button, the display starts cycling continuously.
- ▶ Press the **SET** button to change to the next segment and select the next character.
- ▶ Have you entered the name completely? Press the **SET** button to store your setting and to return to the top menu level.

**RESET****Loading the factory-preset default settings**

Via the “RESET” menu, you can load the factory-preset default settings. Only the selected setting for the pilot tone remains unchanged. After the reset, the transmitter is restarted and the standard display is shown on the display panel.

**PILOT****Activating/deactivating the pilot tone transmission (PILOT)**

Via the “**PILOT**” menu, you can activate or deactivate the pilot tone transmission.

- ▶ When using the transmitter with the tourguide system, the pilot tone transmission must be switched off.

**LOCK****Activating/deactivating the lock mode**

Via the “**LOCK**” menu, you can activate or deactivate the lock mode.

The lock mode prevents that the transmitters are accidentally programmed or switched off during operation. The lock mode icon ⑦ on the display indicates that the lock mode is activated.

To deactivate the lock mode, first press the **SET** button and then press the ▲/▼ buttons to select “**LOC.OFF**”. If you confirm your selection by pressing the **SET** button, the buttons can be operated as usual.

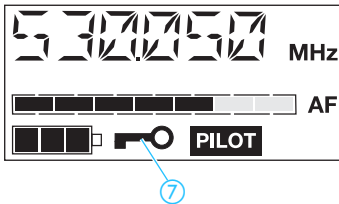
**EXIT****Exiting the operating menu**

Via the “**EXIT**” menu, you can exit the operating menu and return to the standard display.



# Troubleshooting

## Error checklist

Problem	Possible cause	Possible solution
No operation indication	Batteries are flat or rechargeable battery is flat	Replace the batteries or recharge the accupack
No audio signal	Transmitter and receiver are not on the same frequency.	Set transmitter and receiver to the same frequency .
	The transmitter is out of range.	Reduce the distance between transmitter and receiver.
RF signal available, but no audio signal	The transmitter's microphone is muted ("MUTE")	Deactivate the muting function
	Defective microphone	Replace microphone
	Defective headphones	Replace headphones
Audio signal has a high level of background noise	Transmitter sensitivity is adjusted too low	see "Adjusting the sensitivity" on page 47
Audio signal is distorted	Transmitter sensitivity is adjusted too high	see "Adjusting the sensitivity" on page 47
L 2015: red LED flashes besides a charging compartment	No contact with the rechargeable battery (contacts are dirty or rechargeable battery is not inserted correctly)	Clean the contacts or insert the rechargeable battery correctly
	rechargeable battery is defective (overaged or defective rechargeable battery cells)	Replace the accupack
	rechargeable battery temperature is too low or too high	Always charge the rechargeable battery at room temperature
	Batteries (primary cells) or individual rechargeable batteries have been inserted	Only charge the BA 2015 accupack!

If still operating problems with your transmission installation occur, please contact your local Sennheiser agent for assistance.

## Recommendations and tips

### ... for the receiver EK 1038

- Transmission range depends to a large extent on location. There should be a "free line of sight" between transmitting and receiving antennas.

### ... for the radiomicrophones

- Hold the radiomicrophone in the middle of the microphone body. Holding it close to the sound inlet basket will influence the microphone's pick-up pattern, holding it at the lower part of the body will reduce the transmitter's range.
- You can vary the bass reproduction by increasing/decreasing the talking distance to the microphone.
- For best results, make sure that the transmitter sensitivity is correctly adjusted.

### ...for the bodypack transmitters

- Make sure that the antenna and the microphone cable do not cross.
- The antenna should hang or stand freely and be at least 1 cm away from the body. The antenna must not be in direct contact with the skin.
- For best results, make sure that the transmitter sensitivity is correctly adjusted.

## HDX noise reduction

Progress you can hear.

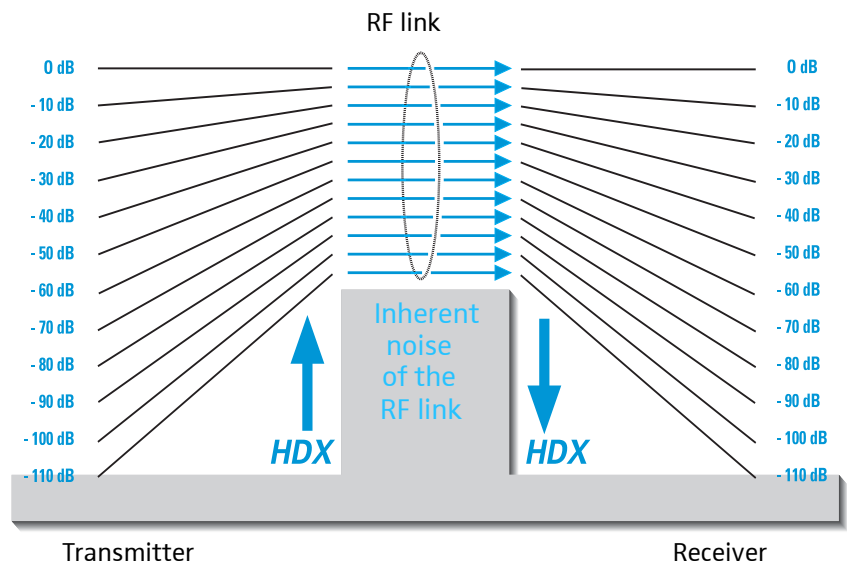

This product family is equipped with HDX, the Sennheiser noise reduction system that reduces RF interference. It increases the signal-to-noise ratio in wireless audio transmission to more than 110 dB.

HDX is a wideband compander system which compresses the audio signal in the transmitter in a 2:1 ratio (related to dB) to lift it above the inherent noise floor of the RF link. A 110 dB dynamic range signal is thus transmitted with an effective dynamic range of only 55 dB, which is above the 60 dB noise floor of the RF link. In the receiver the signal is expanded in an identical and opposite way in a 1:2 ratio to restore the original signal, at the same time reducing the RF noise to below the noise floor of the receiver.

HDX has been specially developed for high quality radiomicrophone systems.

### Note:

Only transmitters and receivers that are equipped with HDX can work correctly with each other. If non HDX equipment was mixed with HDX, the dynamic range would be drastically reduced and the transmission would sound blunt and flat or shrill.

## Accessories and spare parts

### CAUTION!



Components from other manufacturers (e.g. for power supply or accupack) may cause damage to the units and will invalidate the warranty!

- ▶ Only use original Sennheiser accessories and spare parts.

The following accessories are available from your authorized dealer:

### EK 1038 receiver

- BA 2015** Accupack
- L 2015** Charger for BA 2015 accupack
- GP 03** Headphones (stereo jack plug)
- EZT 1011** Induction loop

### L 2015 quick charger

- NT 1** Mains unit for powering a single L 2015 charger with EU mains connector, 230 V
- NT 1-UK** with UK mains connector, 230 V
- NT 1-120** with USA mains connector, 110 V
- NT 3** Mains unit for powering three L 2015 chargers with EU mains connector, 230 V
- NT 3-UK** with UK mains connector, 230 V
- NT 3-120** with USA mains connector, 110 V

### Transmitters of the evolution wireless series, G 2

#### SKM 100 G2 / SKM 300 G2 / SKM 500 G2 radiomicrophone

- MD 835** Microphone head (green identification ring) dynamic, cardioid
- MD 845** Microphone head (blue identification ring) dynamic, super-cardioid
- ME 865** Microphone head (red identification ring), condenser, super-cardioid
- MMD 935** Microphone head (silver identification ring) dynamic, cardioid
- MZW 1** Wind- and popshield
- MZQ 1** Microphone clamp
- BA 2015** Accupack
- L 2015** Charger for BA 2015 rechargeable battery
- KEN** 8 color-coded identification caps for radiomicrophone

**SK 100 G2 / SK 300 G2 / SK 500 G2 bodypack transmitter**

- ME 2** Clip-on microphone, condenser, omni-directional
- MKE 2-ew** Clip-on microphone , black or beige, condenser, omni-directional
- ME 4** Clip-on microphone, condenser, cardioid
- ME 3** Headmic, condenser, super-cardioid
- DC 2** DC power adapter, for external 12 V DC powering (instead of two AA size batteries)
- BA 2015** Accupack
- L 2015** Charger for BA 2015 accupack

**SKP 100 G2 / SKP 500 G2 plug-on transmitter**

- BA 2015** Accupack
- L 2015** Charger for BA 2015 accupack
- POP 1** Plug-on pouch

## Specifications

Temperature range -10°C to +55°C

### EK 1038 receiver

Receiving frequencies 20

Frequency range 830–866 MHz (range E)  
(channel assignment: see table below)

Switching bandwidth 36 MHz

Modulation wideband FM

Nominal/peak deviation ± 24 kHz / ± 48 kHz

RF squelch 4 steps: SQ OFF  
SQ LO: 5 dB $\mu$ V  
SQ MID: 15 dB $\mu$ V  
SQ HI: 25 dB $\mu$ V

Adjacent channel rejection > 70 dB

Noise reduction system Sennheiser [HDX](#)

AF frequency response 40 – 15.000 Hz

Signal-to-noise ratio > 91 dB(A)

THD at nominal deviation and 1 kHz < 1 %, typ. 0.5 %

AF output (headphones) 3.5 mm stereo jack socket

AF output power  
(peak deviation, 1 KHz<sub>NF</sub>) PHONES 2 x ≥ 100 mW at 32  $\Omega$

Min. terminating impedance of the  
headphones 2 x 8  $\Omega$

Power supply BA 2015 rechargeable battery with NiMH cells

Operating time with BA 2015 accupack approx. 6-10 hours depending on volume  
with batteries approx. 6-10 hours depending on volume

Dimensions 82 x 64 x 24 mm

Weight incl. accupack approx. 185 g

### L 2015charger

Input voltage: 10 - 20 V DC via hollow jack socket

Hollow jack: 

Input current: 400 - 750 mA

Charging voltage: 2 x 2.9 V

Charging current: 2 x 700 mA

Charging principle:	$\Delta U$ method Deep discharge recovery charge Trickle charge rechargeable battery temperature monitoring Over/undercharge detection Charging time limit (max. 6 h)
Charging time:	approx. 2.5 h with a totally discharged rechargeable battery and at room temperature, automatic security switch-off after 6 h at the latest
BA 2015 battery type:	2 x 1.2 V 1500 mAh, NiMH
Dimensions:	approx. 145 x 80 x 110 mm
Weight:	approx. 310 g

### Plug-in mains units

Plug-in mains unit for 1 charger	NT 1-EU (Cat. No. 09828), 230 V $\pm 10$ %, 1,8 A, 50 Hz NT 1-UK (Cat. No. 04787), 230 V $\pm 10$ %, 1,9 A, 50 Hz
Plug-in mains unit for up to three chargers	NT 3-EU (Cat. No. 04863), 230 V $\pm 10$ %, 1,8 A, 50 Hz NT 3-UK (Cat. No. 04864), 230 V $\pm 10$ %, 1,9 A, 50 Hz

### evolution wireless transmitters G 2

Modulation	wideband FM
Frequency ranges	518–554, 626–662, 740–776, 786–822, 830–866 MHz 8 channel banks with up to 20 factory-preset channels each
Transmission/receiving frequencies	1 channel bank with up to 20 freely selectable channels (1440 frequencies, tunable in steps of 25 kHz)
RF output power at 50 $\Omega$	typ. 30 mW
Power supply	2 AA size batteries, 1.5 V
power consumption at nominal voltage	$\leq 170$ mA
Operating time	> 8 h (SKP 500 G2 with P48 > 5 h)

### SKM 100 G2 / SKM 300 G2 / SKM 500 G2 radiomicrophone

Dimensions	$\varnothing 50$ x 225 mm
Weight	approx. 450 g

### SK 100 G2 / SK 300 G2 / SK 500 G2 bodypack transmitter

Max. input voltage (at peak deviation)	MICRO: 1.8 V <sub>rms</sub> (unbalanced) LINE: 2.4 V <sub>rms</sub>
Dimensions	82 x 64 x 24 mm

Weight approx. 158 g

### SKP 100 G2 / SKP 500 G2 plug-on transmitter

Max. input voltage (at peak deviation) MICRO: 1.2 V<sub>rms</sub> (unbalanced)

Dimensions 105 x 43 x 43 mm

Weight approx. 195 g

### Channel assignment

		evolution wireless G2, generation 2			
		EK 1038	SKM 100 G2 SK 100 G2 SKP 100 G2	SKM 300 G2 SK 300 G2	SKM 500 G2 SK 500 G2 SKP 500 G2
channel	range E frequency	channel bank 8 menu "TUNE"	channel bank 8 menu "CHAN"	channel bank 8 menu "CHAN"	channel bank 8 menu "CHAN"
1	863,100	1	1	1	1
2	863,500	2	2	2	2
3	864,300	3	3	3	3
4	864,900	4	4	4	4
5	854,100	5		5	5
6	854,600	6		6	6
7	855,300	7		7	7
8	856,200	8		8	8
9	857,300	9			9
10	859,700	10			10
11	861,150	11			11
12	861,600	12			12
13	838,100	13			13
14	839,400	14			14
15	841,100	15			15
16	849,100	16			16

You must check whether or not the product needs to be licensed by the national approval authorities.



# Manufacturer declarations

## Warranty

The original Sennheiser product you have purchased is covered by a warranty of 24 months. The warranty period begins on the date of purchase of brand new, unused products by the first end user. Please retain your sales receipt (or your warranty certificate) as proof of purchase. Unless you submit proof of purchase, which will be verified by your local Sennheiser service partner, you will be obliged to pay for any repairs that are carried out. Proof of purchase must state the date of purchase and name of the product. We shall satisfy our warranty obligations by remedying any material or manufacturing faults free of charge at our discretion either by repair or by exchanging individual parts or the entire appliance. Any defective parts removed from a product during the course of a warranty claim shall become the property of Sennheiser electronic GmbH & Co. KG.

The following cases are not covered by the above warranty:

- minor faults or deviations in the quality of a product which do not affect the product's value or fitness for its intended purpose
- any accessories supplied with the product
- rechargeable and disposable batteries (these products have a shorter service life, the length of which also depends on the frequency of use)
- faults resulting from improper use (e.g. operating errors, mechanical damage, incorrect operating voltage) Proper use for the purposes of this warranty is defined as use of the product under the conditions stated in the instructions for use.
- faults due to wear and tear
- any modification of Sennheiser products effected by you or a third party, unless Sennheiser has given its prior written consent to the nature and extent of the modification
- faults of which the purchaser was already aware at the time of purchase

All warranty claims become void if the product is tampered with by unauthorised persons or repair shops. Warranty claims can be enforced in any country throughout the world in which the statutory rights of the country concerned are not in conflict with our warranty regulations.

No other warranty claims or claims over and above the rights stated in these terms and conditions will be accepted. Consumers may be entitled to statutory rights in their own countries which are not restricted by these warranty terms and conditions, as the warranty is governed by the laws of the country in which the Sennheiser product was purchased by the consumer.

The provisions of the UN Convention on the International Sale of Goods do not apply to this service. If you wish to file a claim under the warranty, please send the product to your local service partner, together with accessories and proof of purchase.

The customer bears the risk of shipment. To avoid any damage in transit, please use the original packaging if possible.

An up-to-date list of all service partners of Sennheiser electronic GmbH & Co. KG worldwide are available on the internet at [www.sennheiser.com](http://www.sennheiser.com) .

### CE Declaration of Conformity

**CE 0682**

This equipment is in compliance with the essential requirements and other relevant provisions of Directives 1999/5/EC, 2004/108/EU or 2006/95/EC. The declaration is available on the internet site at [www.sennheiser.com](http://www.sennheiser.com). Before putting the device into operation, please observe the respective country-specific regulations!

### Batteries or rechargeable batteries



The supplied batteries or rechargeable batteries can be recycled. Please dispose of them as special waste or return them to your specialist dealer. In order to protect the environment, only dispose of exhausted batteries.

### WEEE Declaration



Your Sennheiser product was developed and manufactured with high-quality materials and components which can be recycled and/or reused. This symbol indicates that electrical and electronic equipment must be disposed of separately from normal waste at the end of its operational lifetime. Please dispose of this product by bringing it to your local collection point or recycling centre for such equipment. This will help to protect the environment in which we all live.

### Statements regarding FCC and industry Canada

This equipment has been tested and found to comply with the limits for a Class B digital device, pursuant to Part 15 of the FCC Rules. These limits are designed to provide reasonable protection against harmful interference in a residential installation. This equipment generates, uses and can radiate radio frequency energy and, if not installed and used in accordance with the instructions, may cause harmful interference to radio communications. However, there is no guarantee that interference will not occur in a particular installation. If this equipment does cause harmful interference to radio or television reception, which can be determined by turning the equipment off and on, the user is encouraged to try to correct the interference by one or more of the following measures:

1. Reorient or relocate the receiving antenna.
2. Increase the separation between the equipment and receiver.
3. Connect the equipment into an outlet on a circuit different from that to which the receiver is connected.
4. Consult the dealer or an experienced radio/TV technician for help.

This class B digital apparatus complies with the Canadian ICES-003.

Warning: Changes or modifications made to this equipment not expressly approved by Sennheiser electronic Corp. may void the FCC authorization to operate this equipment.





Sennheiser electronic GmbH & Co. KG  
Am Labor 1  
30900 Wedemark, Germany  
Phone +49 (5130) 600 0  
Fax +49 (5130) 600 300  
[www.sennheiser.com](http://www.sennheiser.com)

Printed in Germany  
Publ. 01/08  
512883/A02

## Free Manuals Download Website

<http://myh66.com>

<http://usermanuals.us>

<http://www.somanuals.com>

<http://www.4manuals.cc>

<http://www.manual-lib.com>

<http://www.404manual.com>

<http://www.luxmanual.com>

<http://aubethermostatmanual.com>

Golf course search by state

<http://golfingnear.com>

Email search by domain

<http://emailbydomain.com>

Auto manuals search

<http://auto.somanuals.com>

TV manuals search

<http://tv.somanuals.com>