



FS15

FLEX-WING
ROTARY CUTTER

Published 07-05

P/N 00773425MB

MASTER PARTS BOOK

S/N 00101 TO 10429

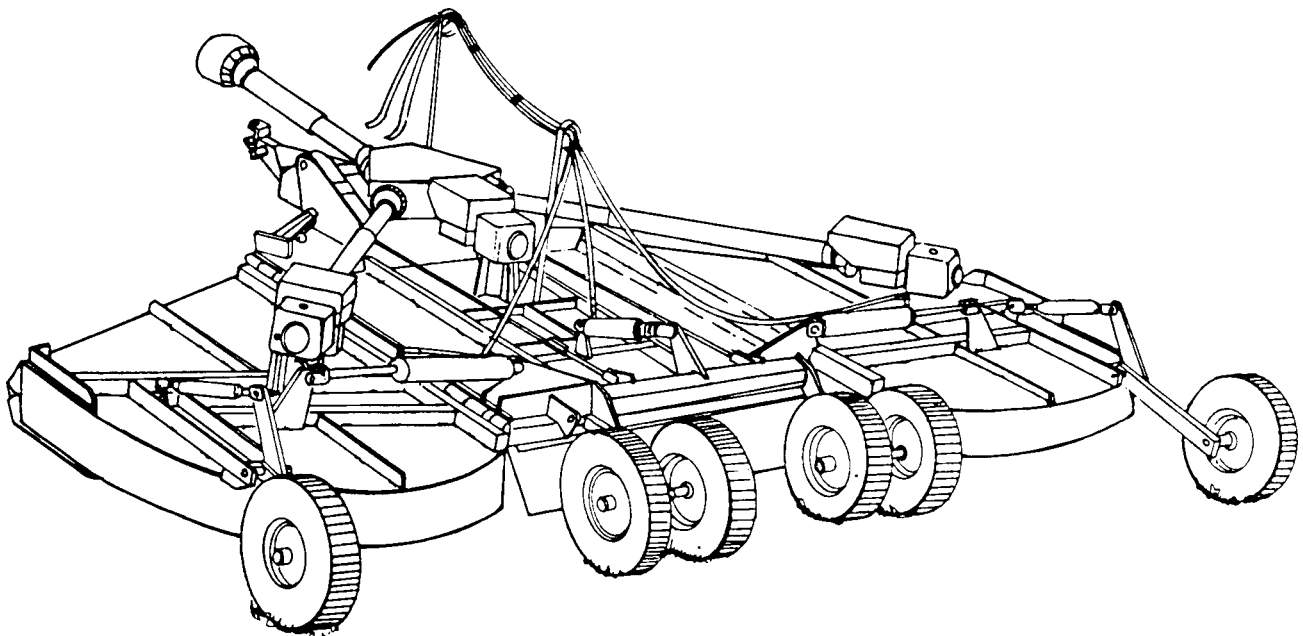

PARTS LISTING

Rhino®

An Alamo Group Company

1020 S. Sangamon Ave.

Gibson City, Il 60936

1-800-446-5158

Email: parts@servis-rhino.com



© 2005 Alamo Group Inc.

TO THE OWNER/OPERATOR/DEALER

All implements with moving parts are potentially hazardous. There is no substitute for a cautious, safe-minded operator who recognizes the potential hazards and follows reasonable safety practices. The manufacturer has designed this implement to be used with all its safety equipment properly attached to minimize the chance of accidents.

BEFORE YOU START!! Read the safety messages on the implement and shown in your manual.
Observe the rules of safety and common sense!

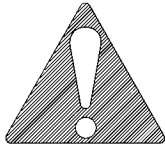

DANGER

FAILING TO FOLLOW SAFETY MESSAGES AND OPERATING INSTRUCTIONS CAN CAUSE SERIOUS BODILY INJURY OR EVEN DEATH TO OPERATOR AND OTHERS IN THE AREA.

1.

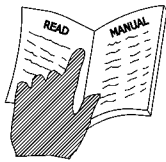

2. NO RIDERS, NO CHILDREN OPERATORS.



3. USE SAFETY SHOES, HARD HAT, SAFETY GLASSES, SEAT BELTS, & ROPS.



4. BLOCK UP SECURELY BEFORE WORKING UNDER.

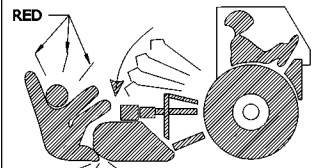

1. Study and understand Operator's Manuals, Safety Signs, and Instructional Decals for tractor & flail mower to prevent misuse, abuse, & accidents. Practice before operating mower in a confined area or near passersby.

● Learn how to stop engine suddenly in an emergency. Be alert for passersby and especially children.

2. Allow no children on or near implement of tractor. Allow no riders on tractor or implement. Falling off can cause serious injury or death from being runover by tractor or mower or contact with Flail Mower Blades.

3. Operate only with tractor having Roll-Over Protective Structure (ROPS) and with seatbelt fastened securely and snugly to prevent injury and possible death from falling off or tractor overturn. Personal Protective Equipment such as Hard Hat, Safety Glasses, Safety Shoes, and Ear Plugs are recommended.

4. Block up or support raised machine and all lifted components securely before putting hands or feet under or working underneath any lifted component to prevent crushing injury or death from sudden dropping or inadvertent operation of controls. Make certain that area is clear before lowering or folding.

5. Before transporting, put Lift Lever in detent or full-lift position. Install Transport Safety Devices securely on folding implements. Slowdown when turning and on hillsides.

● Install Restrictor in folding circuit to slow down lowering and unfolding if action is faster than is desirable.

6. Make certain that SMV sign, Warning Lights, and Reflectors are clearly visible. Follow local traffic codes.

7. Never operate with Flail Mower or Folding Section raised if passersby, bystanders or traffic are in the area to reduce possibility of injury or death from objects thrown by Blades under Shields or implement structure.

8. Before dismounting, secure flail mower in transport position or lower to ground.

● Put tractor in park or set brake, disengage PTO, stop engine, remove key, and wait until noise of rotation has ceased to prevent entanglement in rotating parts which may cause injury or death.

● Never mount or dismount a moving vehicle. Crushing from runover may cause injury or death.

5. TRANSPORT SAFELY, LOCK UP.

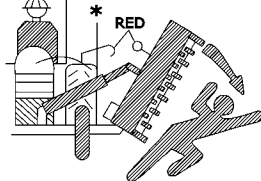

6. USE SMV, LIGHTS, & REFLECTORS.

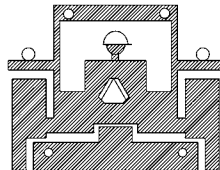

7. DO NOT OPERATE WITH MOWER OR WING RAISED.

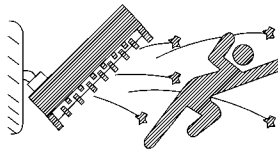

8. DO NOT MOUNT OR DISMOUNT WHILE MOVING.

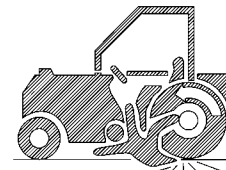

002369

WARRANTY INFORMATION:

Read and understand the complete Warranty Statement found in this Manual. Fill out the Warranty Registration Form in full and return it within 30 Days. Make certain the Serial Number of the Machine is recorded on the Warranty Card and on the Warranty Form that you retain. The use of "will-fit" parts will void your warranty and can cause catastrophic failure with possible injury or death.

PARTS SECTION

PARTS ORDERING GUIDE

The following instructions are offered to help eliminate needless delay and error in processing purchase orders for the equipment in this section.

1. The Parts Section is prepared in logical sequence and grouping of parts that belong to the basic machine featured in this manual. Part Numbers and Descriptions are given to help locate the parts and quantities required.
2. The Purchase Order must include the name and address of the person or organization ordering the parts, who should be charged, and if possible, the serial number of the machine for which the parts are ordered.
3. The Purchase Order must clearly list the quantity of each part, the complete and correct part number (be sure to include all periods), and the basic name of the part.
4. The Manufacturer reserves the right to substitute parts where applicable.
5. Some parts are unlisted items which are special production items not normally stocked and are subject to special handling. Request a quotation for such parts before sending a Purchase Order.
6. The Manufacturer reserves the right to change prices without prior notice.

NOTE: Please refer to The Safety Section in the front of this Manual for the proper Part Number when ordering Replacement Safety Decals.



For maximum safety and to guarantee optimum product reliability, always use genuine Servis-Rhino Parts. The use of inferior replacement parts may cause premature or catastrophic failure which could result in serious injury or death. Direct any questions regarding parts to:



RHINO®
1020 S. Sangamon Ave.
Gibson City, IL 60936
800-446-5158
Email: parts@servis-rhino.com

PART NAME INDEX

AXLE ASSEMBLY - CTR & WING S/N 00101 - 10147 OCT 1977 - JAN 1988.....	5
AXLE ASSEMBLY - CTR & WING S/N 10148 - 10429 JAN 1988 - MAY 1988.....	6
BLADE BAR ASSEMBLY - CTR HEAVY DUTY S/N 01162 - 10429 DEC 1980 - MAY 1988.....	7
BLADE BAR ASSEMBLY - CTR STANDARD S/N 00101 - 01162 OCT 1977 - DEC 1980.....	8
BLADE BAR ASSEMBLY - WING HEAVY DUTY S/N 01162 - 10429 DEC 1980 - MAY 1988.....	9
BLADE BAR ASSEMBLY - WING STANDARD S/N 01162 - 10429 OCT 1977 - DEC 1980.....	10
BLADE PAN ASSEMBLY - CTR HEAVY DUTY S/N 01162 - 10429 DEC 1980 - MAY 1988.....	11
BLADE PAN ASSEMBLY - CTR STANDARD S/N 00101 - 01162 OCT 1977 - DEC 1980.....	12
BLADE PAN ASSEMBLY - WING HEAVY DUTY S/N 01162 - 10429 DEC 1980 - MAY 1988.....	13
BLADE PAN ASSEMBLY - WING STANDARD S/N 00101 - 01162 OCT 1977 - DEC 1980.....	14
CHAIN GUARD - CENTER & WING SECTION S/N 01497 - 10429 JUN 1982 - MAY 1988.....	15
CHAIN GUARD - REAR CENTER SECTION S/N 01497 - 10429 JUN 1982 - MAY 1988.....	16
CHAIN GUARD - REAR WING SECTION S/N 01497 - 10429 JUN 1982 - MAY 1988.....	17
CYLINDER ASSEMBLY - CENTER AXLE S/N 00101 - 01377 OCT 1977 - JAN 1982.....	18
CYLINDER ASSEMBLY - CENTER AXLE S/N 00101 - 10429 OCT 1977 - MAY 1988.....	19
CYLINDER ASSEMBLY - CENTER AXLE S/N 01376 - 10429 JAN 1982 - MAY 1988.....	20
CYLINDER ASSEMBLY - LEVEL LIFT - 2-1/2 X 8 SLAVE CYL S/N 00101 - 10429 OCT 1977 - MAY 1988.....	21
CYLINDER ASSEMBLY - LEVEL LIFT - 2-3/4 X 8 SLAVE CYL S/N 00101 - 10429 OCT 1977 - MAY 1988.....	22
CYLINDER ASSEMBLY - LEVEL LIFT - 3 X 8 SLAVE CYL S/N 00101 - 10429 OCT 1977 - MAY 1988.....	23
CYLINDER ASSEMBLY - LEVEL LIFT REPLACEMENT ASSY (P/N 8719) S/N 00101 - 10429 OCT 1977 - MA.....	24
CYLINDER ASSEMBLY - LEVEL LIFT REPLACEMENT ASSY (P/N 8720) S/N 00101 - 10429 OCT 1977 - MA.....	25
CYLINDER ASSEMBLY - LEVEL LIFT REPLACEMENT ASSY (P/N 8721) S/N 00101 - 10429 OCT 1977 - MA.....	26
CYLINDER ASSEMBLY - WING-HYDRAULIC CYLINDER & HOSE GROUP S/N 00101 - 01376 OCT 1977 - JAN.....	27
CYLINDER ASSEMBLY - WING-LANTEX HYDRAULIC CYL & HOSE GRP S/N 01377 - 10429 JAN 1982 - MAY.....	28
CYLINDER ASSEMBLY - WING-REPLACEMENT S/N 00101 - 10429 OCT 1977 - MAY 1988.....	29
DECALS S/N 00101 - 10429 OCT 1977 - MAY 1988.....	30
DEFLECTOR - REAR WING S/N 01497 - 10429 JUN 1982 - MAY 1988.....	31
DEFLECTOR - RUBBER FRONT CENTER S/N 00101 - 10429 OCT 1977 - MAY 1988.....	32
DEFLECTOR - RUBBER FRONT WING LEFT & RIGHT S/N 00101 - 10429 OCT 1977 - MAY 1988.....	33
DEFLECTOR - RUBBER LEFT & RIGHT CENTER S/N 00101 - 10429 OCT 1977 - MAY 1988.....	34
DRIVELINE ASSEMBLY - CTR GEARBOX SQUARE SHAFT SLIP 35R S/N 00101 - 10429 OCT 1977 - MAY 19.....	35
DRIVELINE ASSEMBLY - OUTBOARD SQUARE SHAFT ASSEMBLY 35R S/N 00101 - 10429 OCT 1977 - MAY 1.....	36
DRIVELINE ASSEMBLY - PTO SQUARE SHAFT ASSEMBLY 44R S/N 00101 - 10429 OCT 1977 - MAY 1988.....	37
DRIVELINE ASSEMBLY - SHIELDING ASSEMBLY SQUARE SHAFTS S/N 00101 - 10429 OCT 1977 - MAY 198.....	38
GEARBOX ASSEMBLY - CENTER SECTION S/N 00101 - 10429 OCT 1977 - MAY 1988.....	40
GEARBOX ASSEMBLY - DIVIDER (COMER) S/N 01901 - 10429 FEB 1985 - MAY 1988.....	42
GEARBOX ASSEMBLY - DIVIDER S/N 00101 - 01900 OCT 1977 - FEB 1985.....	44
GEARBOX ASSEMBLY - LEFT WING S/N 00101 - 10429 OCT 1977 - MAY 1988.....	46
GEARBOX ASSEMBLY - RIGHT WING S/N 00101 - 10429 OCT 1977 - MAY 1988.....	48
GEARBOX ATTACHMENT - DIVIDER & CENTER GEARBOX S/N 00101 - 10429 OCT 1977 - MAY 1988.....	50
GEARBOX ATTACHMENT- RIGHT & LEFT WING GEARBOX S/N 00101 - 10429 OCT 1977 - MAY 1988.....	51
HOSE BRACKET COMPONENTS S/N 00101 - 10429 OCT 1977 - MAY 1988.....	52
HUB ASSEMBLY - CENTER & OUTBOARD S/N 10148 - 10428 JAN 1988 - MAY 1988.....	53
HUB ASSEMBLY - OUTBOARD AXLES S/N 00101 - 10147 OCT 1977 - JAN 1988.....	54
HUB ASSEMBLY - STANDARD CENTER AXLE S/N 00101 - 10147 OCT 1977 - JAN 1988.....	55
HYDRAULIC CONTROL VALVE MOUNTING KIT S/N 00101 - 10429 OCT 1977 - MAY 1988.....	56
HYDRAULIC HOSE ADAPTERS S/N 00101 - 10429 OCT 1977 - MAY 1988.....	57
HYDRAULIC VALVE ASSEMBLY - DETENT W/SPRING ASSEMBLY S/N 00101 - 10429 OCT 1977 - MAY 1988.....	58
HYDRAULIC VALVE ASSEMBLY - OPEN/CLOSED CENTER VALVE S/N 00101 - 10429 OCT 1977 - MAY 1988.....	59
JACK ASSEMBLY - TOP WING S/N 00101 - 10429 OCT 1977 - MAY 1988.....	60
LEFT SCREW S/N 00101 - 10429 OCT 1977 - MAY 1988.....	61
LEVEL LIFT KIT FIELD INSTALLATION S/N 00101 - 10429 OCT 1977 - MAY 1988.....	62
LEVEL LIFT ROD ASSEMBLY S/N 10148 - 10428 JAN 1988 - MAY 1988.....	63
MAINFRAME ASSEMBLY S/N 00101 - 01900 OCT 1977 - FEB 1985.....	64
MAINFRAME ASSEMBLY S/N 01901 - 10429 FEB 1985 - MAY 1988.....	65
NOTES.....	39
SIDE SHOE & SIDE SKIRT - OFFSET MODELS CTR SECTION S/N 00101 - 10429 OCT 1977 - MAY 1988.....	66
SIDE SHOE & SIDE SKIRT S/N 00101 - 10429 OCT 1977 - MAY 1988.....	67
SKID SHOE ASSEMBLY S/N 00101 - 00466 OCT 1977 - FEB 1979.....	68
SKID SHOE ASSEMBLY S/N 00101 - 10429 OCT 1977 - MAY 1988.....	69
SPRING ASSEMBLY - CENTER AXLE S/N 00101 - 10429 OCT 1977 - MAY 1988.....	70
SPRING ASSEMBLY - WING S/N 00101 - 10429 OCT 1977 - MAY 1988.....	71
TIRE/WHEEL ASSEMBLY S/N 00101 - 10429 OCT 1977 - MAY 1988.....	72

PART NAME INDEX

TONGUE ASSEMBLY S/N 00101 - 10429 OCT 1977 - MAY 1988	73
TORQUE LIMITER ASSEMBLY S/N 00101 - 10001 OCT 1977 - AUG 1987	74
TORQUE LIMITER ASSEMBLY S/N 10001 - 10429 AUG 1987 - MAY 1988	75
WEIGHT BOX S/N 00101 - 10429 OCT 1977 - MAY 1988	76
WINCH AND STAND ASSEMBLY S/N 00101 - 10429 OCT 1977 - MAY 1988	77

AXLE ASSEMBLY - CTR & WING S/N 00101 - 10147 OCT 1977 - JAN 1988

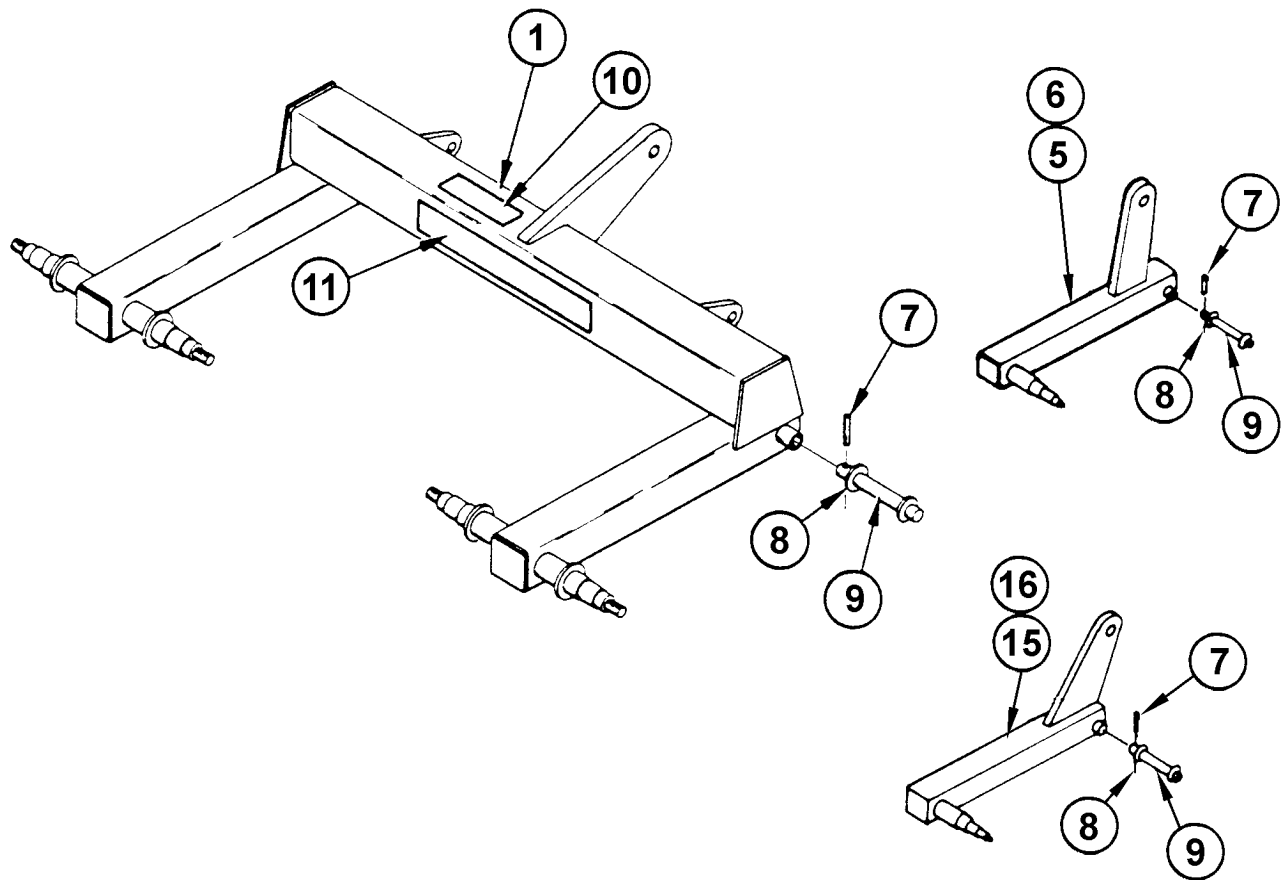

ITEM	PART NO.	QTY.	DESCRIPTION
1	0656060100	1	CENTER AXLE WELD NOT SHOWN
	0656280100	1	DOUBLE AXLE WELD SHOWN
5	0656070110	1	AXLE WLD R.H. ONLY
	0656070100	1	AXLE ASSY
6	0656070210	1	AXLE WLD L.H. ONLY
	0656070200	1	AXLE ASSY
7	20BH5012	4	PIN-SPIRAL 5/16 X 1 1/2 *
8	15B1600	4	WASHER 1 SAE P *
9	65106A4	4	WLDMT,AXLE PIVOT PIN *
10	D121	1	DECAL ADJ-NUTS
11	D301	1	DECAL,RHINO
15	0652140220	1	WLDMT, AXLE ARM - LEFT **
	0652140210	15	LEFT AXLE ASSY **
16	0652140260	1	WLDMT, AXLE ARM - RIGHT
	0652140250	1	RIGHT AXLE ASSY **

Note: This Axle uses hub #3741247 assembly on center and hub #271033 assembly on wing. Washers are welded to spindle on center axle but not on the wing.

FOR REPLACEMENT PARTS ONLY

*QTY SHOWN FOR 1 MACHINE, COMPLETE

**USED W/FACTORY LEVEL LIFT ONLY ITEM #15 AND #16

AXLE ASSEMBLY - CTR & WING S/N 10148 - 10429 JAN 1988 - MAY 1988

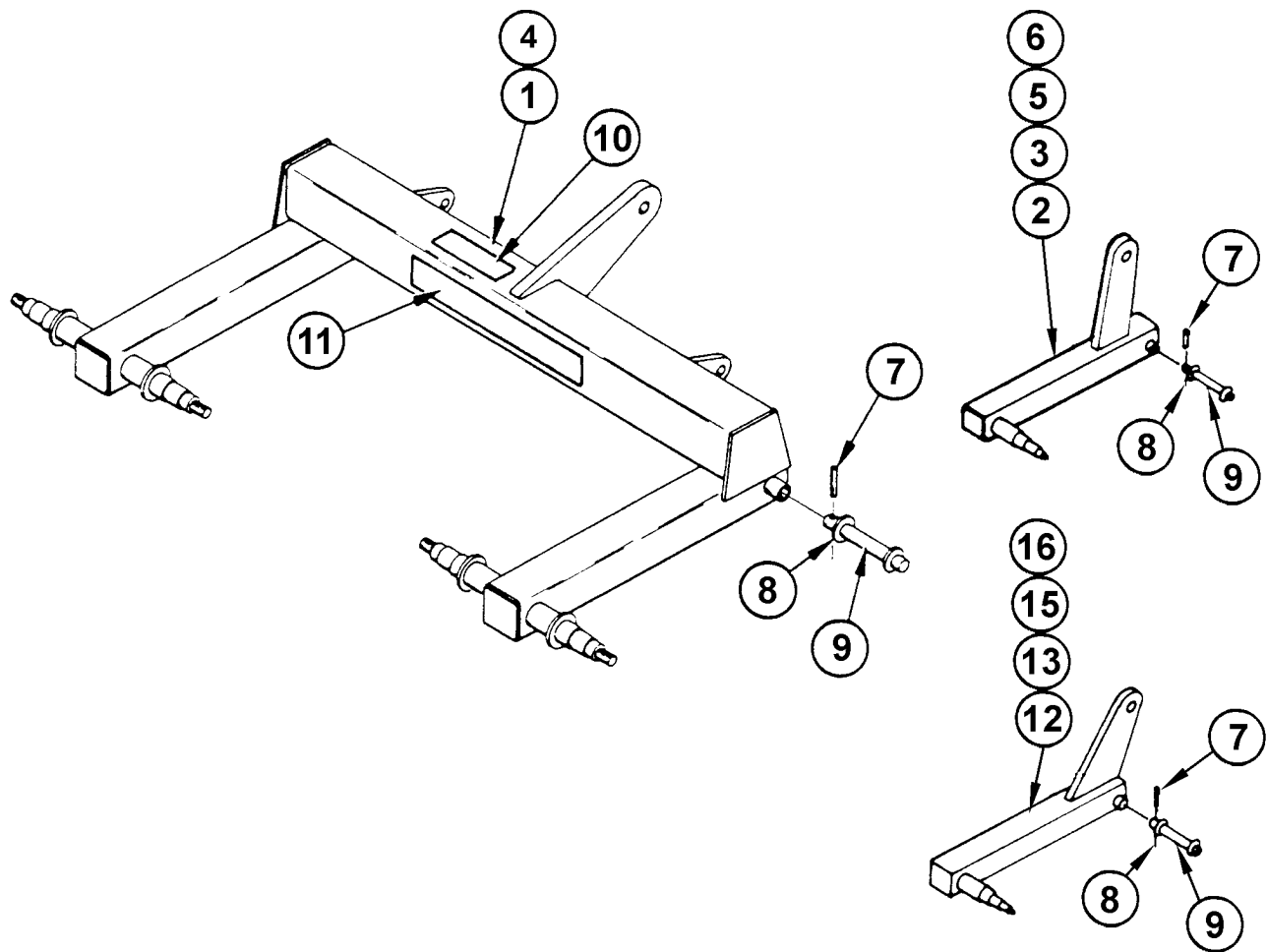

ITEM	PART NO.	QTY.	DESCRIPTION
1	00756458	1	AXLE CENTER ASSY NOT SHOWN
	00756456	1	AXLE DOUBLE CENTER SHOWN
2	00756461	1	AXLE ARM ASSY (R.H.), COMPLETE W/1 HUB
3	00756464	1	AXLE ARM ASSY(L.H.), COMPLETE W/1 HUB
4	00756455	1	DOUBLE AXLE ARM WELD SHOWN
	00756457	1	CENTER AXLE WELD NOT SHOWN
5	00756459	1	AXLE WELD (R.H.) ONLY
6	00756462	1	AXLE WELD (L.H.) ONLY
7	20BH5012	4	PIN-SPIRAL 5/16 X 1 1/2 *
8	15B1600	4	WASHER 1 SAE P *
9	65106A4	4	WLDMT,AXLE PIVOT PIN *
10	D121	1	DECAL ADJ-NUTS
11	D301	1	DECAL,RHINO
12	00756466	1	LEFT AXLE ARM ASSY
13	00756468	1	RIGHT AXLE ARM ASSY
15	00756465	1	LEFT AXLE ARM WELD N/S
16	00756467	1	RIGHT AXLE ARM WELD

Note: This axle center & win uses hub #00757241 assembly.

FOR REPLACEMENT PARTS ONLY.

*QTY SHOWN FOR 1 MACHINE, COMPLETE

**USED W/FACTORY HYDRAULIC LEVEL LIFT ONLY ITEM #12 THRU #16

BLADE BAR ASSEMBLY - CTR HEAVY DUTY S/N 01162 - 10429 DEC 1980 - MAY 1988

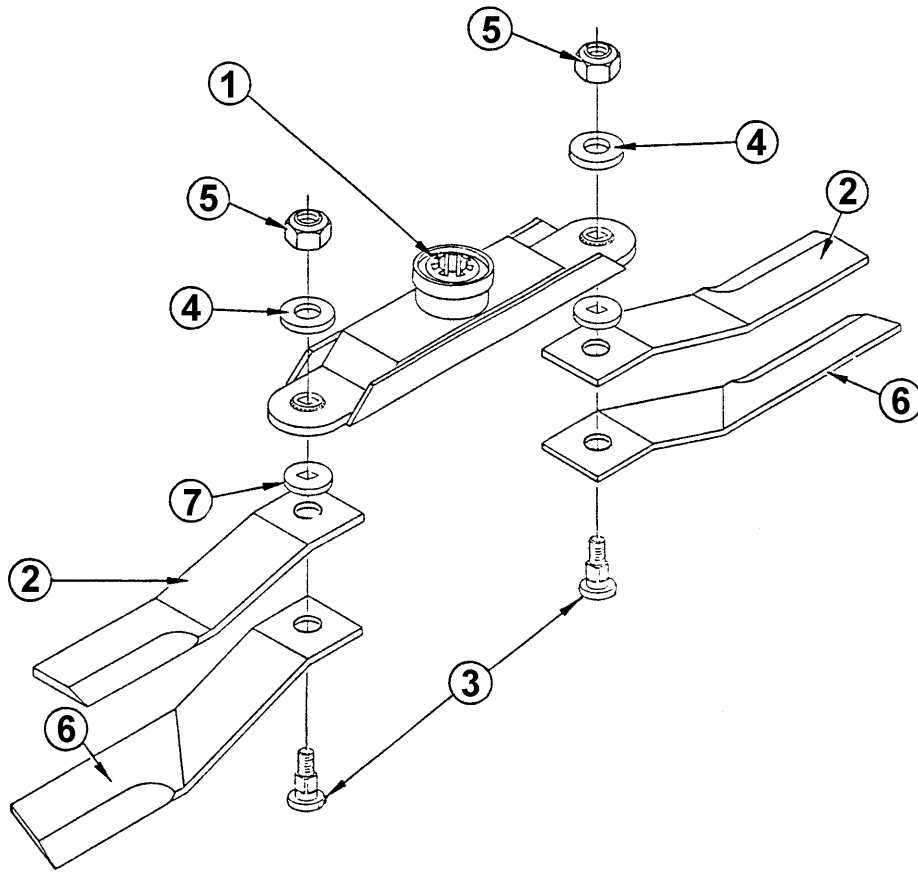

ITEM	PART NO.	QTY.	DESCRIPTION
1	0656160100	1	WLDMT, BLADE CARRIER
2	0652010030	2	BLADE, CCW/CW FLAT
3	571044	2	BOLT SHOULDER
4	571045	2	WASHER
5	5GL16140	2	LOCKNUT 1 -14 LH TLN PL
6	0622010330	2	BLADE, CCW FAN
7	0656150200	2	WASHER,SQ HOLE HT

Note: This carrier was optional until Dec. 1980 then, it became standard. These blade bolts have square shoulders. The blade bolt hole is 1-25/64 diameter. Check Before Ordering Parts

BLADE BAR ASSEMBLY - CTR STANDARD S/N 00101 - 01162 OCT 1977 - DEC 1980

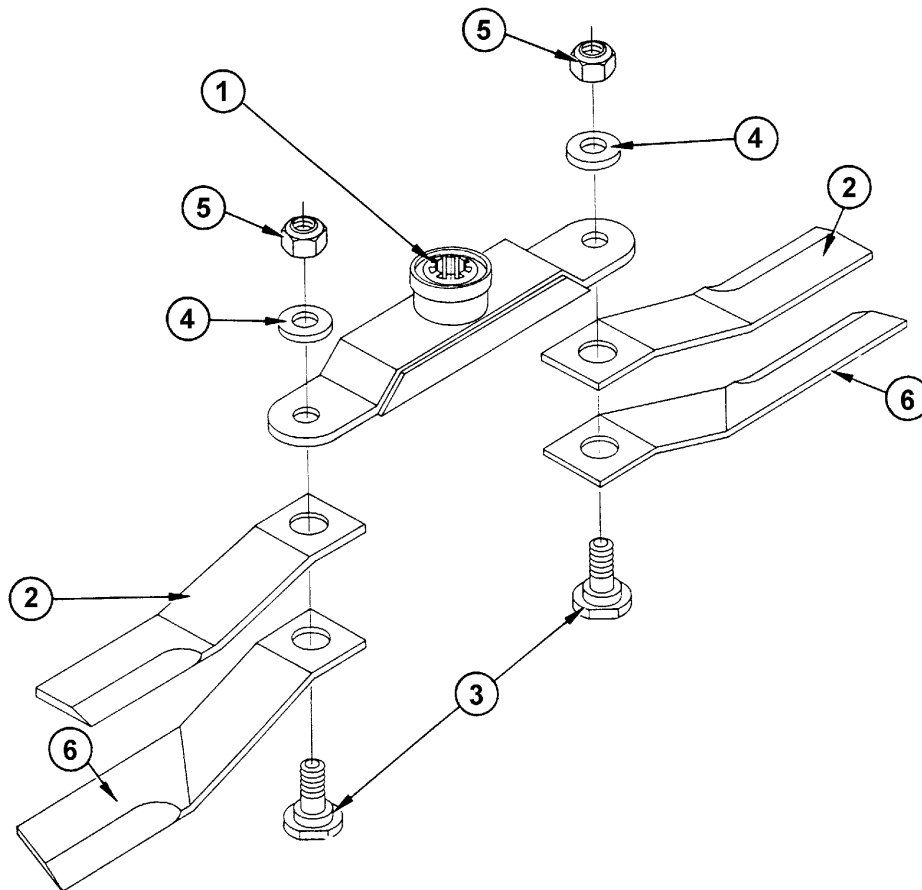

ITEM	PART NO.	QTY.	DESCRIPTION
1	701021R	1	CARRIER,BAR BLADE
2	701022R	2	BLADE
3	36107A2ALH	2	BOLT SHOULDER L.H THREAD
4	481043	2	SPCR 1-1/4 X 3/4 X 5/16
5	5GL12160	2	LOCKNUT TLM 3/4 NF PLB L.H. THREAD
6	71103	2	BLD,OFT/FAN,CCW

Note: This blade carrier was standard till Dec. 1980. These Blade bolts have round shoulder.
The blade bolt hole is 1-1/64 dia. Check Before Ordering Parts

BLADE BAR ASSEMBLY - WING HEAVY DUTY S/N 01162 - 10429 DEC 1980 - MAY 1988

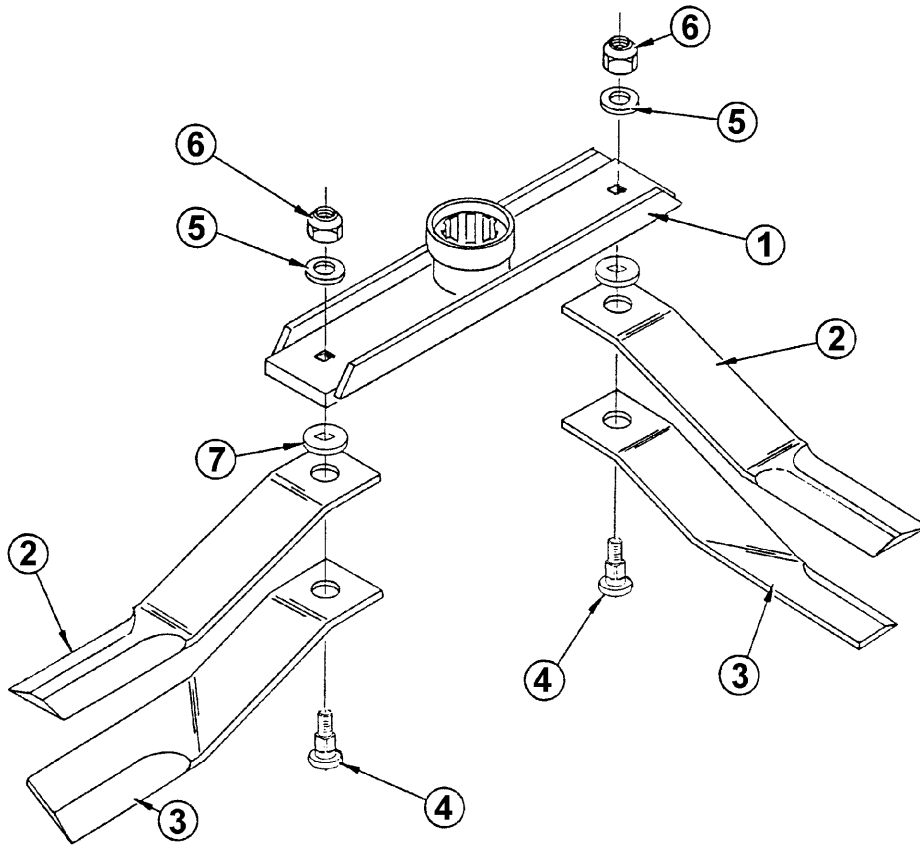

ITEM	PART NO.	QTY.	DESCRIPTION
1	0656180100	1	WLDMT, BLADE CARRIER, FS15
2	0652010030	2	BLADE, CCW/CW FLAT
3	0622010330	2	BLADE, CCW FAN
	0652010330	3	BLADE, CW FAN
4	571044	2	BOLT SHOULDER
5	571045	2	WASHER
6	5GL16140	2	LOCKNUT 1 -14 LH TLN PL
7	0656150200	2	WASHER,SQ HOLE HT

Note: This was optional till Dec. 1980. These blades bolts have square shoulders.

The blade bolt hole is 1-25/64 dia. Check Before Ordering Parts

BLADE BAR ASSEMBLY - WING STANDARD S/N 01162 - 10429 OCT 1977 - DEC 1980

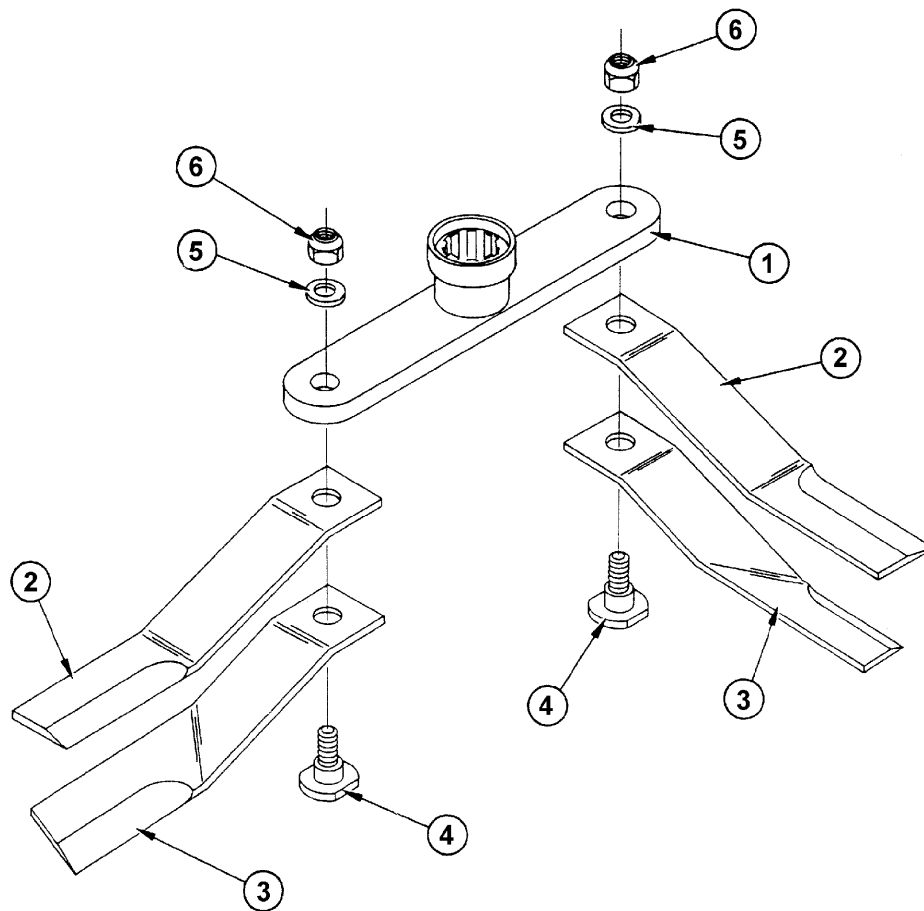

ITEM	PART NO.	QTY.	DESCRIPTION
1	711021	1	BLADE CARRIER
2	701022R	2	BLADE
	0656240000	2	BLADE STD FAN
3	71103	2	BLD,OFT/FAN,CCW
4	36107A2ALH	2	BOLT SHOULDER
5	5312316	2	WASHER (SPECIAL)
6	5GL12160	2	LOCKNUT TLM (LH) 3/4 NF PLB

Note: This blade carrier was optional till Dec. 1980.

The blade bolt hole is 1-1/64 dia. Check Before Ordering Parts

BLADE PAN ASSEMBLY - CTR HEAVY DUTY S/N 01162 - 10429 DEC 1980 - MAY 1988

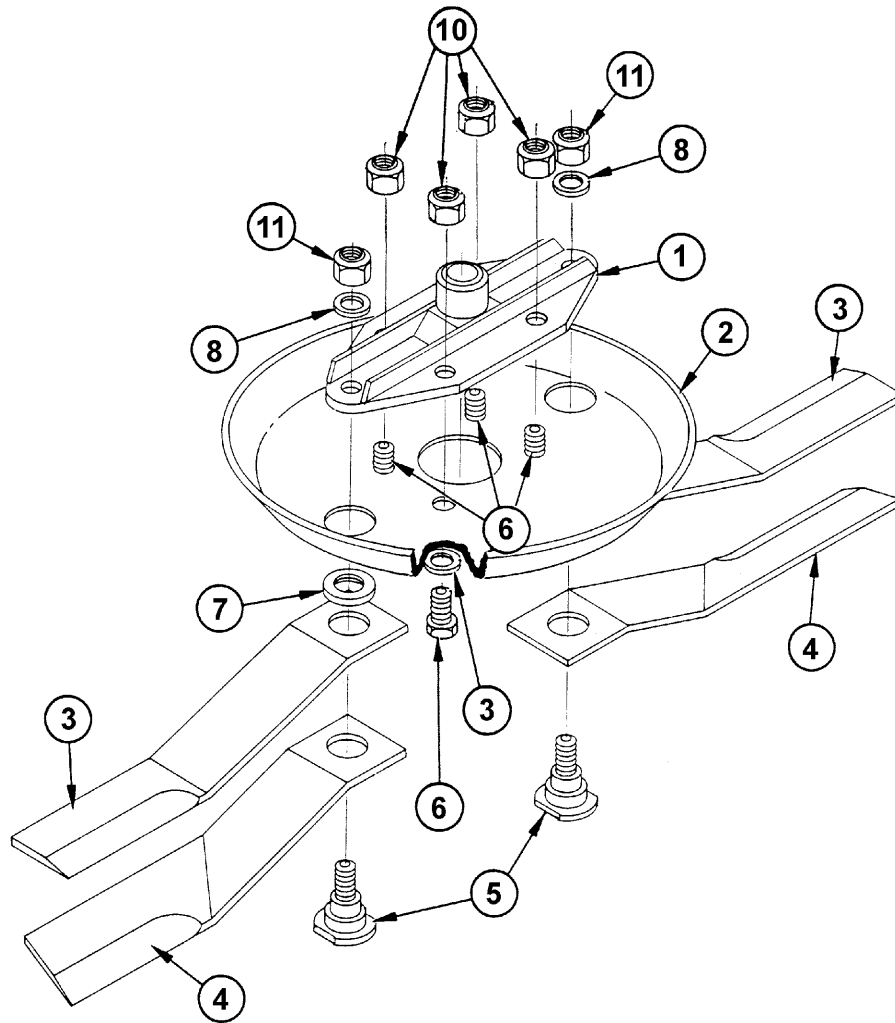

ITEM	PART NO.	QTY.	DESCRIPTION
1	0656150100	1	BALDE CARRIER WELDMENT
2	701332	1	DISHPAN
3	0652010030	2	OFFSET FLAT BLADE
	0652010030	3	HARD SURFACED OFFSET FLAT BLADE
4	0622010330	2	OFFSET FAN BLADE
5	571044	2	OFFSET HARD SURFACED FAN BLADE
6	7AH5101816	4	BOLT
7	0656150200	2	SPACER WASHER
8	571045	2	SHOULDER BOLT
9	W67	4	HARD WASHER
10	00749136	4	LOCKNUT
11	5GL1640	2	LOCKNUT L.H. THREAD

Note: This carrier was optional until Dec. 1980 then, it became standard. These blade bolts have square shoulders. The blade bolt hole is 1-25/64 diameter. Check Before Ordering Parts

BLADE PAN ASSEMBLY - CTR STANDARD S/N 00101 - 01162 OCT 1977 - DEC 1980

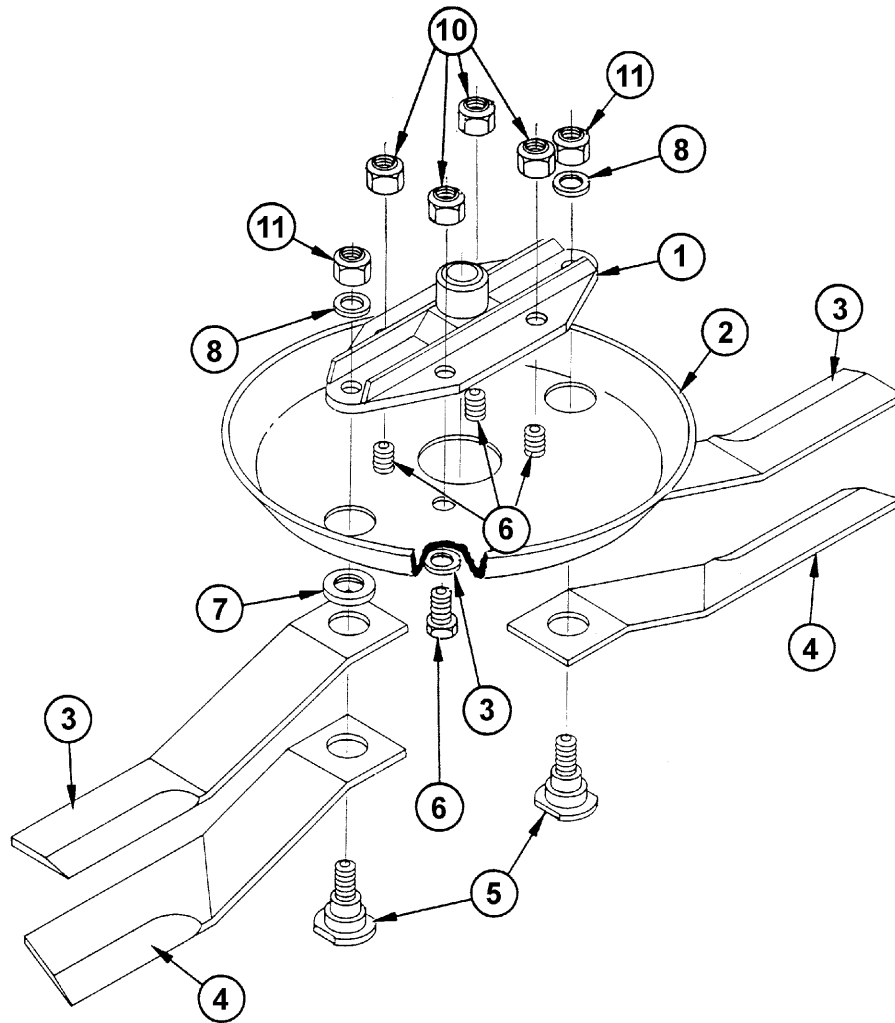

ITEM	PART NO.	QTY.	DESCRIPTION
1	701333	1	CARRIER BLADE WELDMENT
2	701332	1	DISHPAN
3	701022R	2	BLADE, OFFSET FLAT
4	71103	2	BLADE, OFFSET FAN
	HS71103	2	BLADE OFFSET FAN (HARD SURFACED)
5	36107A2ALH	2	SHOULDER BLADE BOLT
6	7AH5101816	4	BOLT
7	671044	2	SPACER WASHER
8	681064	2	WASHER (HARDENED)
9	W67	4	WASHER (HARDENED)
10	5GR10180	4	NUT-TOPLOCK
11	5GL12160	2	NUT-TOPLOCK LH THREAD

Note: This blade carrier was standard till Dec. 1980. These Blade bolts have round shoulder.
The blade bolt hole is 1-1/64 dia. Check Before Ordering Parts

BLADE PAN ASSEMBLY - WING HEAVY DUTY S/N 01162 - 10429 DEC 1980 - MAY 1988

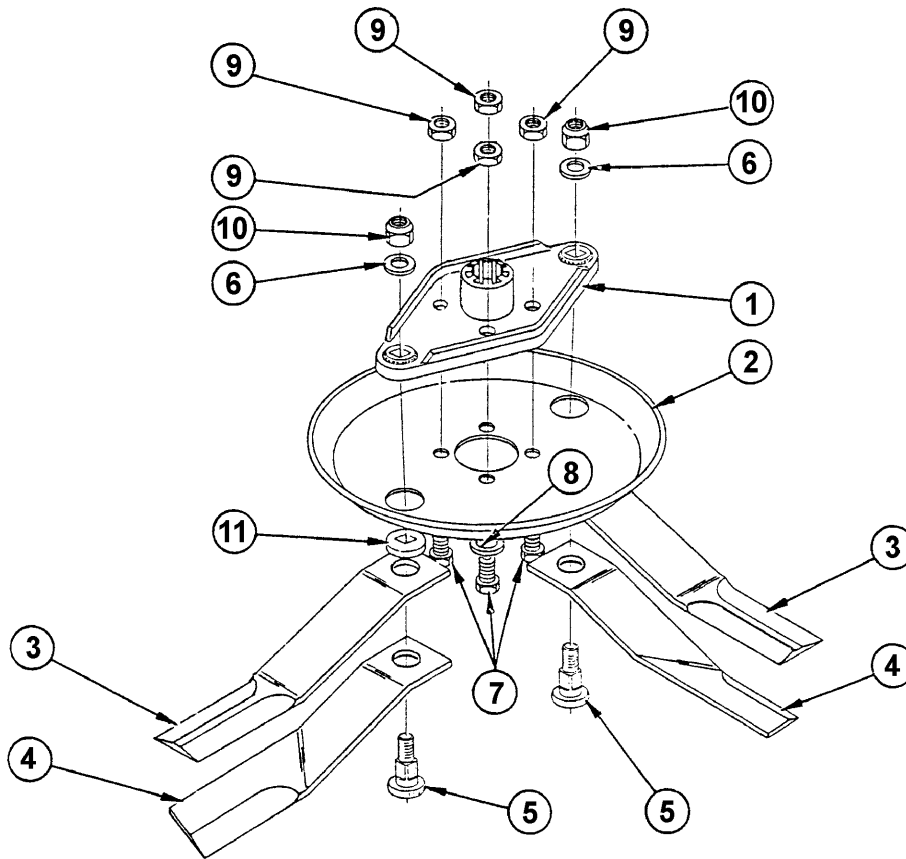

ITEM	PART NO.	QTY.	DESCRIPTION
1	0656170100	1	BLADE CARRIER, WELDMENT
2	671042	1	BLADE PAN
3	0652010030	2	OFFSET FLAT BLADE, CCW
	0652010030	3	OFFSET FLAT BLADE, HARD SURFACED, CCW
	0652010030	2	OFFSET FLAT BLADE, CW
	0652010030	3	OFFSET FLAT BLADE, HARD SURFACED, CW
4	0622010330	2	OFFSET FAN BLADE, CCW
	0622010330	4	OFFSET FAN BLADE, HARD SURFACED, CCW
	0652010330	2	OFFSET FAN BLADE, CW
	0652010330	2	FAN, BLADE HARD SURFACED, CW
5	571044	2	SHOULDER BOLT (L.H. THREADS)
6	571045	2	SHOULDER BOLT WASHER
7	7AH5101816	4	BOLT
8	W67	4	WASHER
9	00749136	4	LOCKNUT
10	5GL16140	2	LOCKNUT L.H. THREADS
11	0656150200	2	WASHER SPACER

Note: This was optional till Dec. 1980. These blades bolts have square shoulders.
The blade bolt hole is 1-25/64 dia. Check Before Ordering Parts

BLADE PAN ASSEMBLY - WING STANDARD S/N 00101 - 01162 OCT 1977 - DEC 1980

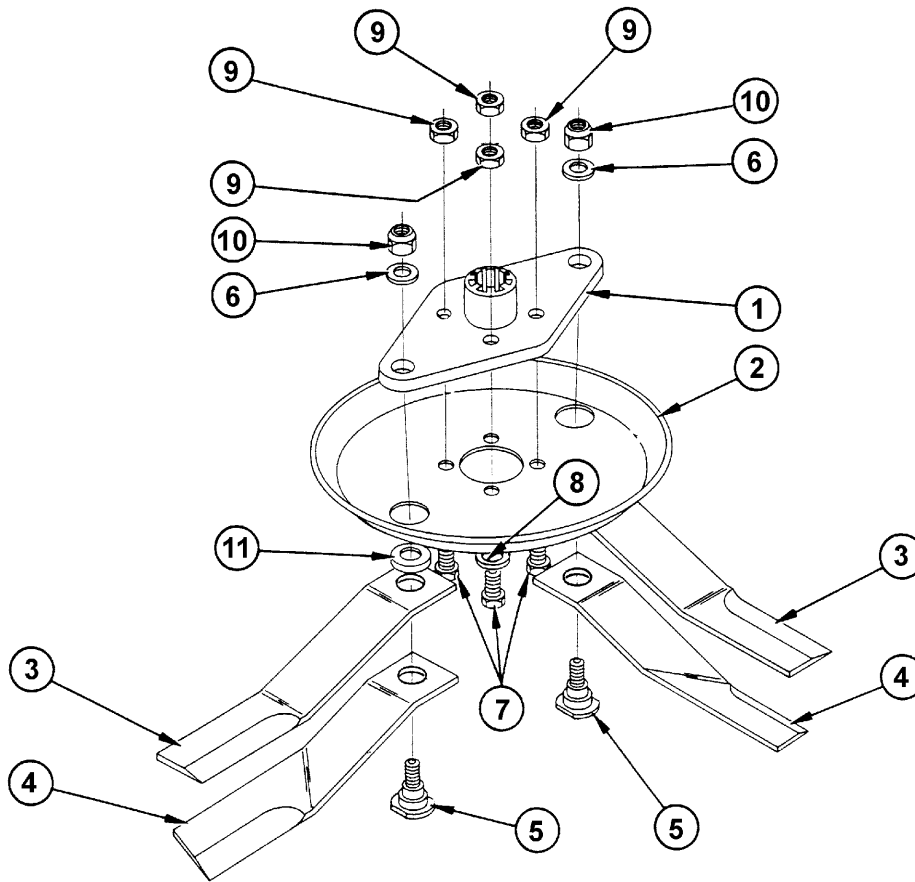

ITEM	PART NO.	QTY.	DESCRIPTION
1	671041	1	CARRIER, BLADE (WELDMENT)
2	671042	1	BLADE PAN
3	701022R	2	BLADE, OFFSET, CCW
	0656240000	2	BLADE, OFFSET, CW (HARD SURFACE)
	0656240000	2	BLADE, OFFSET, CW
4	71103	2	BLADE, SUCTION, CCW
	0656240000	2	BLADE, SUCTION, CW
	71103	2	BLADE, SUCTION, HARD SURFACED, CCW
	0656240000	2	BLADE, SUCTION, HARD SURFACED, CW
5	36107A2ALH	2	BOLT, SHOULDER L.H. THD.
6	5312316	2	WASHER, SPECIAL (HEAT TREATED)
7	7AH5101816	4	BOLT
8	W67	4	WASHER, HARD
9	00749136	4	NUT, LOCK HEX.
10	5G112160	2	NUT, LOCK HEX.
11	671044	2	WASHER, SPACER

Note: This blade carrier was optional till Dec. 1980.
The blade bolt hole is 1-1/64 dia. Check Before Ordering Parts

CHAIN GUARD - CENTER & WING SECTION S/N 01497 - 10429 JUN 1982 - MAY 1988

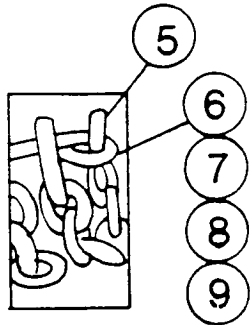
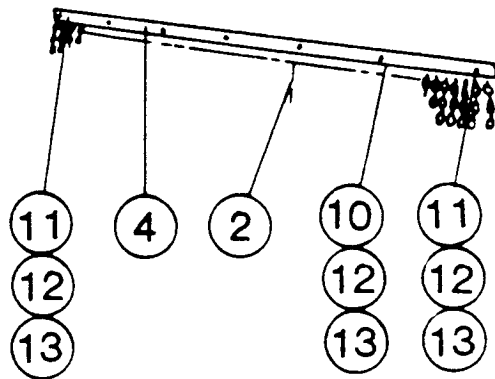
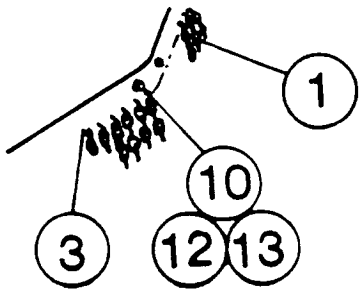

ITEM	PART NO.	QTY.	DESCRIPTION
	0652100000	-	CHAIN GUARDS, FRONT
1	0652100100	1	CTR SECT FRNT CHN GD ASSY
2	0652100200	1	FRNT CHN GD ASSY, WING *
3	0652100110	1	WLDMT, MOUNTING BRACKET
4	0652100201	1	GUARD MNTING BRKT *
5	0652100101	69	CHAIN 5/16 5-LINKS
	0652100203	63	CHAIN 5/16, 6 LINK *
6	0652100202	1	ROD CHAIN *
7	0652100104	2	ROD CHAIN
8	0652100102	1	ROD CHAIN
9	0652100105	2	ROD CHAIN
10	7A81312	7	C/S1/2 X 1 1/2 NC
		5	(WING) *
11	00013300	2	HEXB 1/2 NC 2 PL5 *
12	15B800	7	WASHER 1/2 SAE ZP
		7	(WING) *
13	5GR8130	7	NUT, LOCKNUT 1/2 NC
		7	(WING) *

Note: These replace assembly used prior to Serial #07497 June 1982. Chain Guards with chain links welded on longer available.

Leading edge of mower will be turned down 90° approximately.

CHAIN GUARD - REAR CENTER SECTION S/N 01497 - 10429 JUN 1982 - MAY 1988

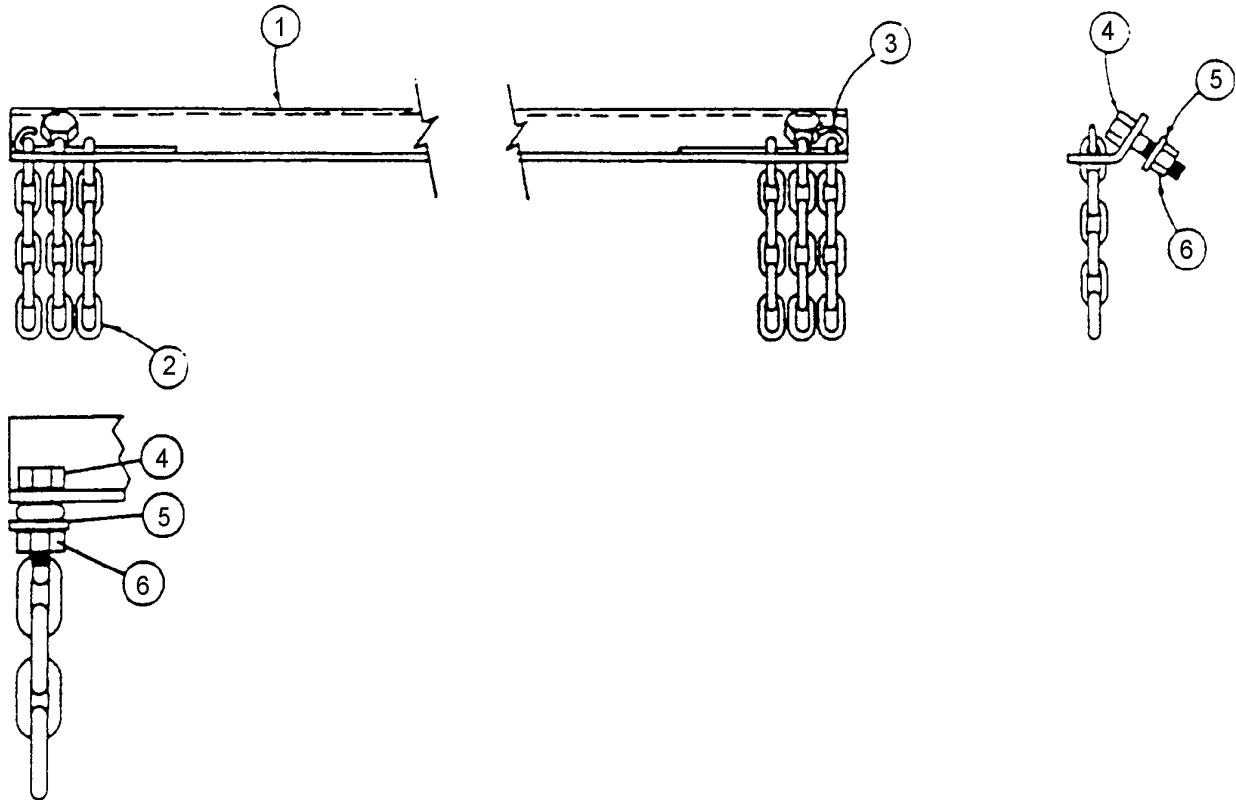

ITEM	PART NO.	QTY.	DESCRIPTION
	0652110000	-	CHAIN GUARDS, REAR *
	0652110100	1	REAR CHN GD ASSY, CTR SECT
1	0652110101	1	MOUNTING BRACKET
2	0652100203	57	CHAIN 5/16, 6 LINK
3	0652110102	1	ROD,CHAIN GUARD 52 1/2 LG
4	00748823	4	HHCS 1/2-13UNC 1-1/2 PL5
	00752680	2	HHCS 1/2-13UNC X 4LG PL5
5	15B800	6	WASHER 1/2 SAE ZP
6	00001800	6	LOCKNUT TLM 1/2 NC PLB
7	0652110103	2	ROD,CHAIN GUARD 11 1/2 LG
?8	652053	2	SPACER

Note: These chain guards as an assembly replace earlier chain guards prior to serial #01497 June 1982. Chain guards with chain links welded on bracket are no longer available.

CHAIN GUARD - REAR WING SECTION S/N 01497 - 10429 JUN 1982 - MAY 1988

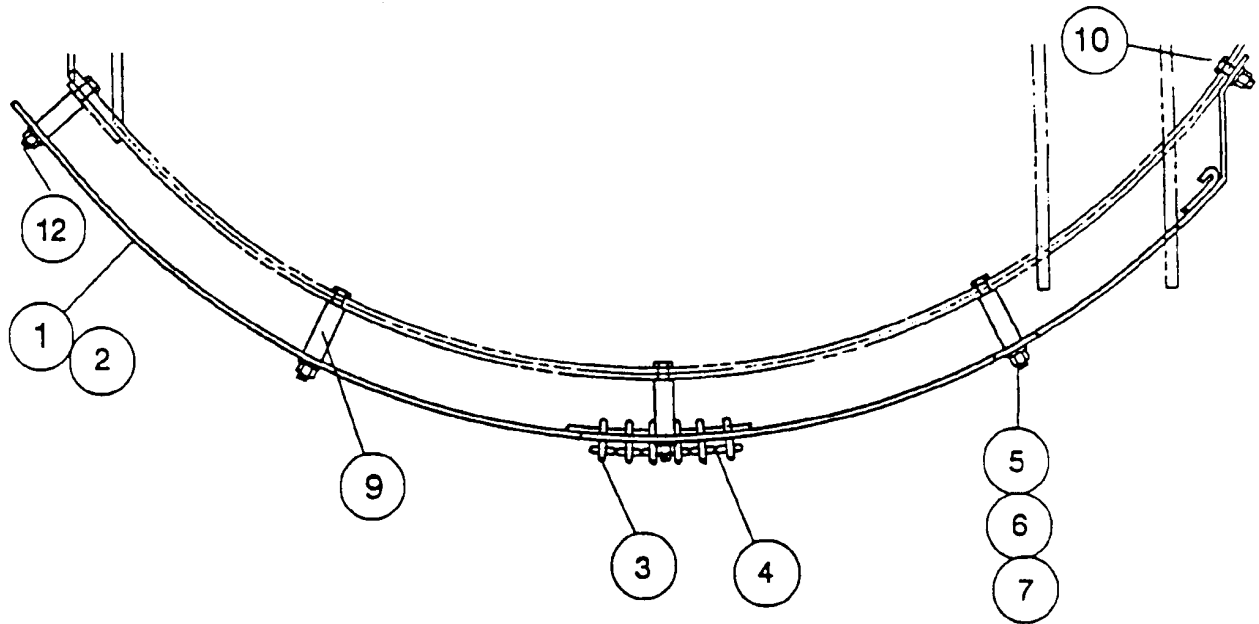

ITEM	PART NO.	QTY.	DESCRIPTION
1	0652110300	1	LEFT REAR WING CHN GD
	0652110200	1	RT REAR CHN GD ASSY
2	0652110210	1	MOUNTING BRKT, RIGHT
	0652110310	2	MOUNTING BRKT, LEFT
3	00751126	110	CHAIN 5/16 WLD 6 LINK
4	0652110201	2	ROD CHAIN
5	00013300	2	HEXB 1/2 NC 2 PL5
9	652053	8	SPACER
10	00752680	6	HHCS 1/2-13UNC X 4LG PL5
12	7A81336	2	C/S1/2 X 4-1/2 NC PL5

Complete Rear Chain Guard Assembly to include center, left and right wing. See Center Chain Guard Section. These are the same for all previous serial #'s listed without modification. Chain Guards with welded on links are no longer available.

CYLINDER ASSEMBLY - CENTER AXLE S/N 00101 - 01377 OCT 1977 - JAN 1982

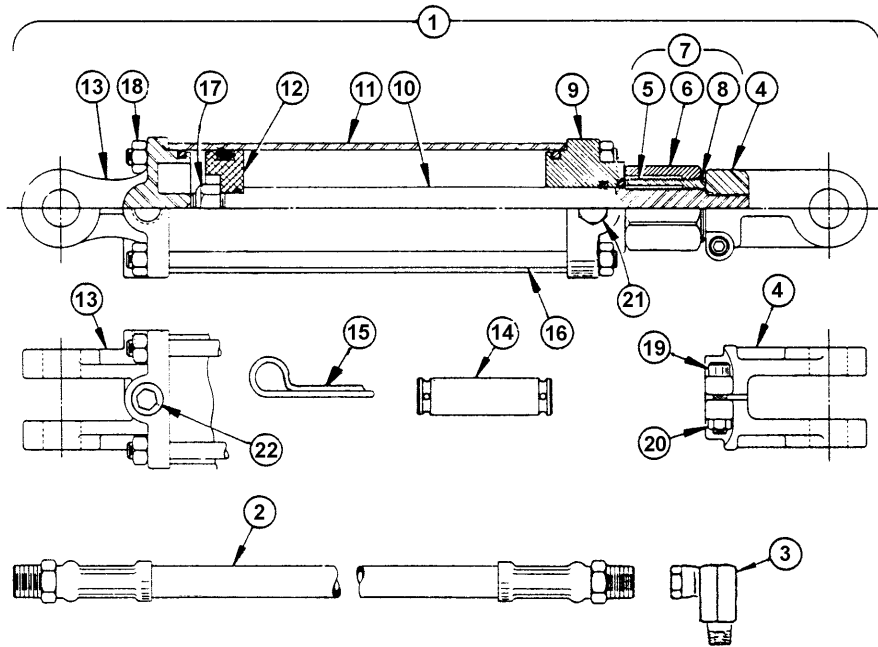

ITEM	PART NO.	QTY.	DESCRIPTION
1	65113B1	1	CYLINDER
	00759946	1	CYLINDER 3 X 8 W/1-1/4 ROD
	00755234	1	CONTROL SPACER KIT
2	651302	1	HOSE #6 - 8 MP - 8 MP 180 LG
3	94514	1	ADAPTER, HYD, ELBOW SWIVEL
4	691354	1	CLEVIS 1 1/4-12 NF THD
	65113A3	1	CLEVIS 1/16-12 NF THD
7	65113B6	1	COLLAR
	651136	1	COLLAR
9	65113B8	1	HEAD 1 1/4 ROD 3 BR
	65113A8	1	HEAD 1 1/16 ROD 3 BR
10	65113A9	1	ROD 1 1/4
	651139	1	ROD, 1-1/16 DIA., 3/4NF THDS.
11	6511310	1	TUBE CENTER CYL
12	691315	1	PISTON, 3, O RING SEAL
	6511311	1	PISTON, 3, UCUP SEAL
13	65113A12	1	CLEVIS BASE 1/2
	0651130001	1	CLEVIS BASE 7/16
14	8354	2	PIN-HYD. CYLINDER
15	37107B13	2	CLIP-X HAIR PIN
16	65113A16	4	TIE ROD 1/2 - 13
	0651130017	4	TIE ROD
17	6511320	1	NUT, PISTON (3/4-NF HEX)
18	00001200	1	NUT, HEX 1/2 NC PL
	00999316	4	NUT HEX 7/16 NC PL
19	6511322	1	BOLT
20	00013901	1	NUT HEX 3/8 NC PL
21	6511324	1	BREATHER, 1/2 SQ HD CORED
22	00749508	1	PLUG 1/2-14 NPT
	2717100	-	SEAL KIT 1 1/4
	6511325A	-	SEAL KIT, 3 CROSS CYLINDER 1 1/16

Note: This cylinder was used approx. through 1982. Always check length of barrel, type of stroke control, size and rod (Item #10), size of tie rods. (Item #16) before ordering parts. Replacement part # for complete assembly is 00759946 and the stroke control spacer kit is 00755234. This cylind

CYLINDER ASSEMBLY - CENTER AXLE S/N 00101 - 10429 OCT 1977 - MAY 1988

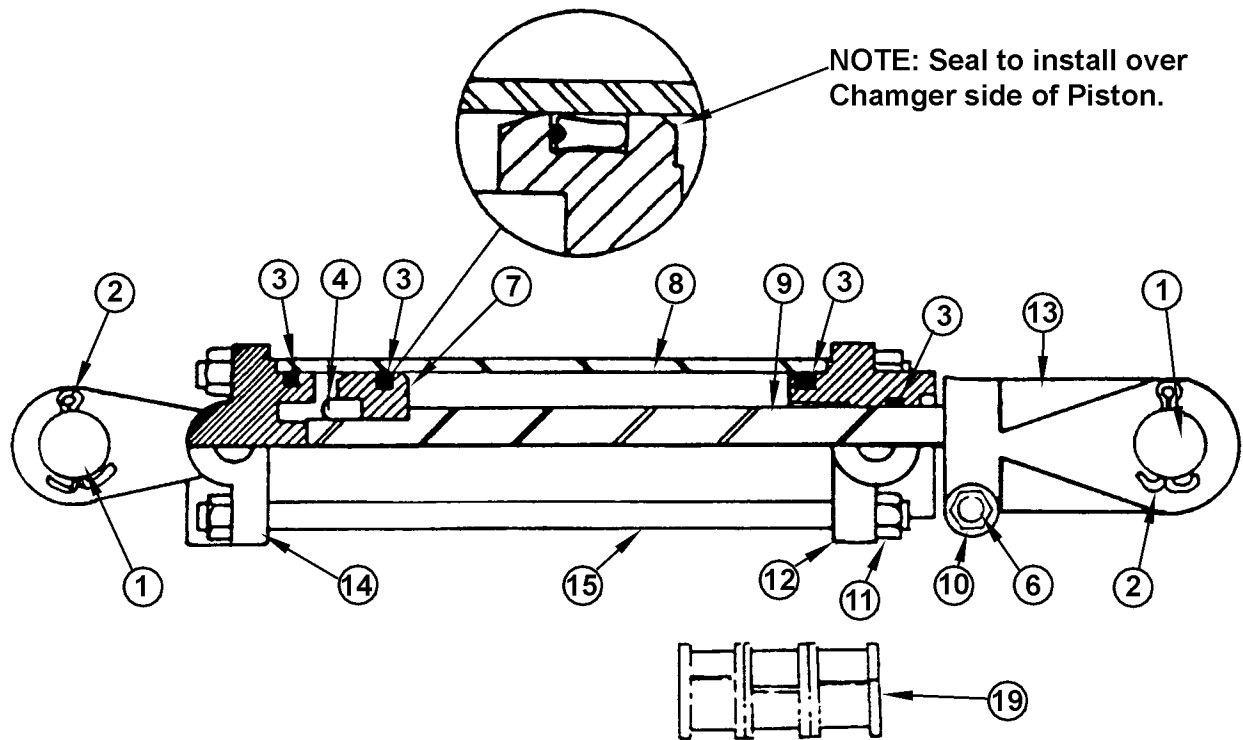

ITEM	PART NO.	QTY.	DESCRIPTION
	00759946		CYLINDER 3 X 8 W/1-1/4 ROD
1	8354	2	PIN-HYD. CYLINDER
2	163016	2	PIN, COTTER 3/16 X 2
3	00760199	1	SEAL KIT (3 DIA HYD CYL)
4	4675M	1	NUT PISTON
5	7339	1	BREATHER, CYLINDER
6	00023100	1	HHCS 3/8 -16UNC 1-1/2 PL5
7	00760661	1	PISTON FOR 3BORE CYL
8	00760194	1	TUBE, CYL 3X8
9	00760200	1	PISTON ROD
10	4376	1	NUT HEX 1/2-20 NF PL
11	4690W	8	INSTALL SHEET-BELT TENSIONER&S
12	00760197	1	HEAD, CYL 3
13	8754	1	CLEVIS, OUTER
14	00760196	1	BASE, CYL 3
15	00760202	4	ROD, CYL TIE (1/2NFX13)3X8 CYL
19	00755234	1	CONTROL SPACER KIT
	00760199		SEAL KIT (3 DIA HYD CYL)

REPLACEMENT PARTS ONLY

Replacement cylinder not used in production. Used as replacement assembly. Parts WILL NOT interchange with earlier cylinder.

Note: No screw on stroke control - use clip on spacers. (Item # 19)

Seal Kit # 00760199 contains both old and new style piston seals. New style seal can be installed in old style piston.

CYLINDER ASSEMBLY - CENTER AXLE S/N 01376 - 10429 JAN 1982 - MAY 1988

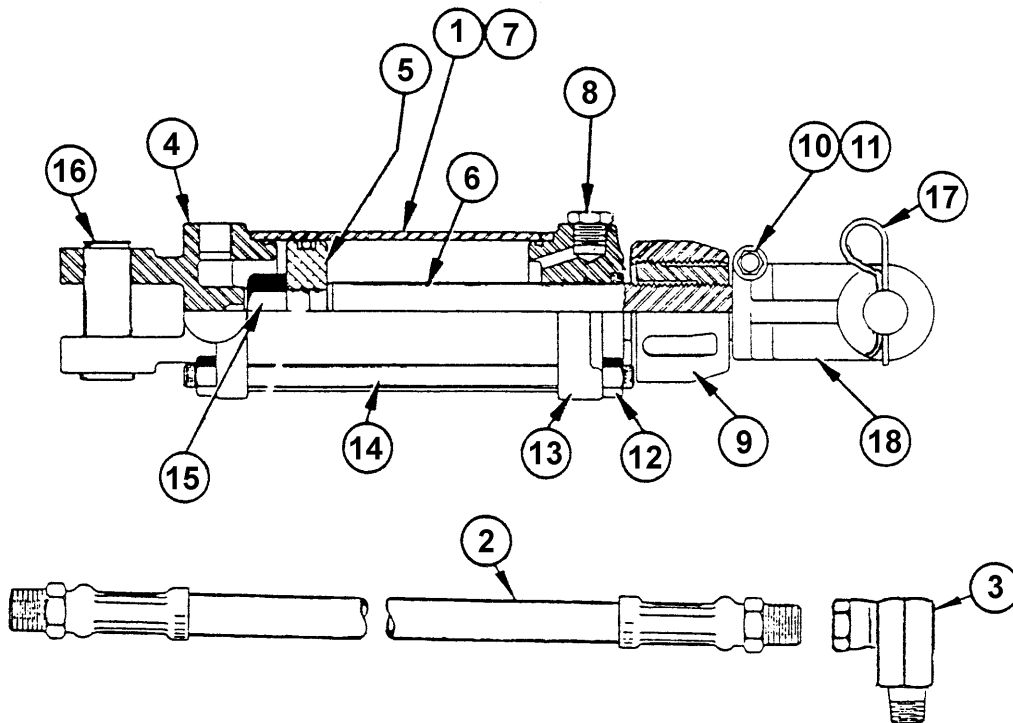

ITEM	PART NO.	QTY.	DESCRIPTION
1	65113B1	1	CYLINDER
2	651302	1	HOSE #6 - 8 MP - 8 MP 180 LG
3	94514	1	ADAPTER, HYD, ELBOW SWIVEL
4	0651130001	1	CLEVIS BASE
5	0651130005	1	PISTON
6	0651130006	1	ROD
7	0651130007	1	BARREL
8	00750208	1	PLUG,BREATHER 1/2 NPTM - 007
9	0651130012	1	STROKE CONTROL
10	5B6240	1	NUT,ROD CLEVIS
11	7E62414	1	SHCS 3/8 NF 1-3/4
12	02816800	8	NUT 1/2 NF HEX
13	0651130016	1	HEAD 3 HYD CYL 1-1/4 ROD
14	0651130017	4	TIE ROD
15	691351	1	NUT
16	8354	2	PIN-HYD. CYLINDER
17	00000400	4	PIN-COTTER 1/8 X 1-1/2 PLATED
18	0651130022	1	CLEVIS 1-14 NF THD
	0651130014	-	SEAL KIT,3 LANTEX CYLINDER

Note: This cylinder was used approx. after 1982. Always check length of barrel, and type of stroke control before ordering part. Replacement part # for complete cylinder assy is 00759946, and stroke control spacer kit is 00755234. Parts Will Not Interchange.

This is an lantex cylinder length of barrel (Item #7) is 10 1/8" long. Stroke control (Item #9) is round with notches cast into it.

CYLINDER ASSEMBLY - LEVEL LIFT - 2-1/2 X 8 SLAVE CYL S/N 00101 - 10429 OCT 1977 - MAY 1988

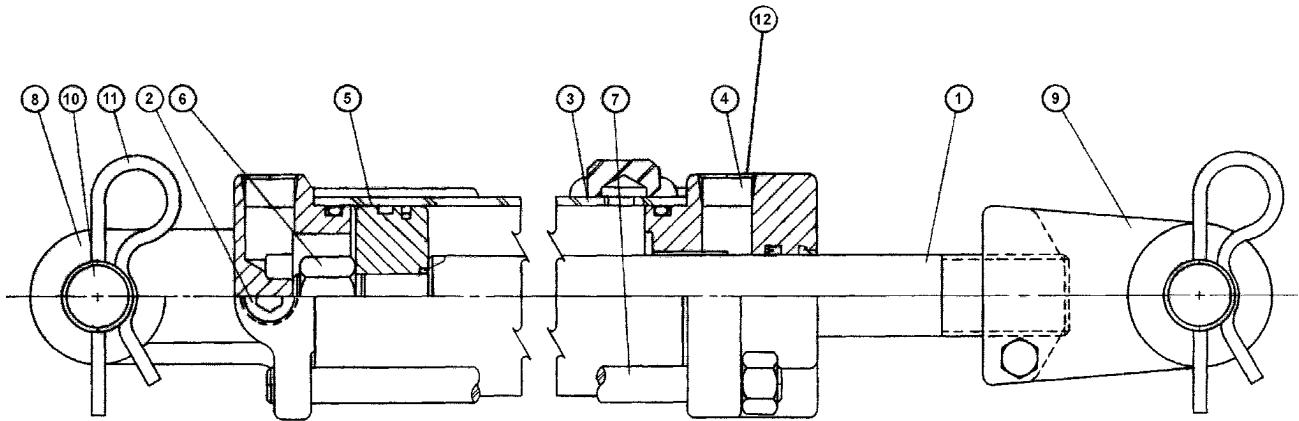

ITEM	PART NO.	QTY.	DESCRIPTION
	0652141500	-	CLY, LEVEL LIFT
1	0652141501	1	PISTON ROD
2	0652141312	1	PLUG, STRAIGHT ADAPTER
3	0652141502	1	TUBE
4	0652141503	1	HEAD
5	0652141504	1	PISTON
6	5JRC10180	1	NUT TOPLOCK 5/8 NF PLC
7	0652140305	4	TIEROD, HYD CYL W/NUT
8	0652141506	1	CLEVIS, BASE
9	0652140307	1	CLEVIS, ROD
10	691356	2	PIN
11	37107B13	4	CLIP-X HAIR PIN
12	0652141311	2	ADP HYD STGHT 8MB - 8FP
13	691302	1	HYD HOSE-3/8-8W/ 1/2 FITTING (NOT SHOWN)
14	B651302	1	HOSE #6 - 8MP - 8MP - 180LG (NOT SHOWN)
15	6513015	1	HOSE #6 - 8 MP - 8 MP 216 LG (NOT SHOWN)
16	B65113A2	1	HYD HOSE ONE (NOT SHOWN)
17	94514	6	ADAPTER, HYD, ELBOW SWIVEL (NOT SHOWN)

CYLINDER ASSEMBLY - LEVEL LIFT - 2-3/4 X 8 SLAVE CYL S/N 00101 - 10429 OCT 1977 - MAY 1988

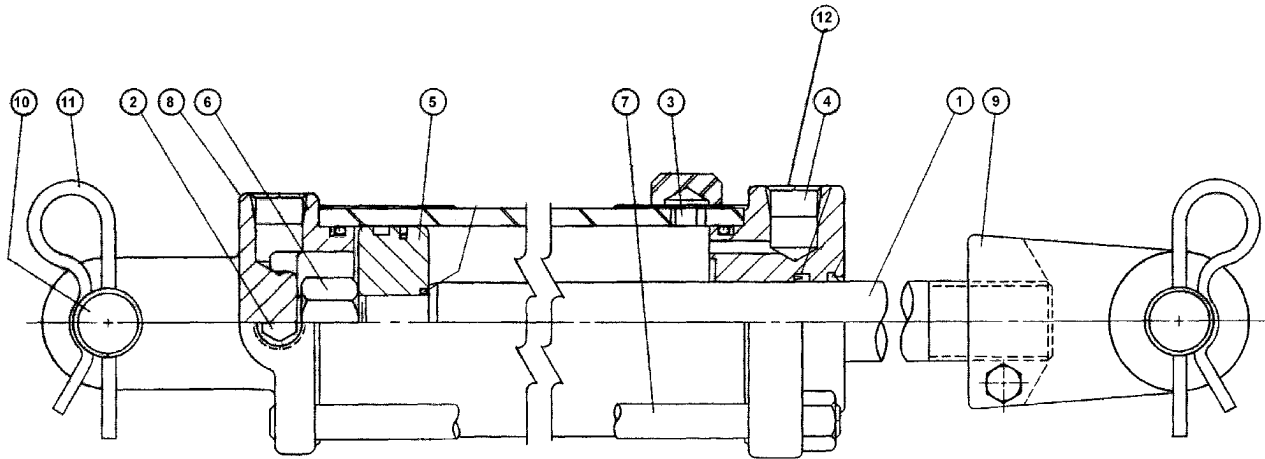

ITEM	PART NO.	QTY.	DESCRIPTION
	0652141400	-	HYD CYL KIT
1	0652141401	1	ROD,PISTON
2	0652141312	1	PLUG, STRAIGHT ADAPTER
3	0652141402	1	TUBE HYD CYL
4	0652141403	1	GLAND,ROD END
5	0652141404	1	PISTON
6	5JRC12100	1	NUT TOPLOCK 3/4
7	0652140305	4	TIEROD,HYD CYL W/NUT
8	0652141406	1	CLEVIS,BASE
9	0652140307	1	CLEVIS, ROD
10	691356	2	PIN
11	37107B13	4	CLIP-X HAIR PIN
12	0652141311	2	ADP HYD STGHT 8MB - 8FP
13	691302	1	HYD HOSE-3/8-8W/(1/2FITTING (NOT SHOWN)
14	B651302	1	HOSE #6 - 8MP - 8MP - 180LG (NOT SHOWN)
15	6513015	1	HOSE #6 - 8 MP - 8 MP 216 LG (NOT SHOWN)
16	B65113A2	1	HYD HOSE ONE (NOT SHOWN)
17	94514	6	ADAPTER, HYD, ELBOW SWIVEL (NOT SHOWN)

CYLINDER ASSEMBLY - LEVEL LIFT - 3 X 8 SLAVE CYL S/N 00101 - 10429 OCT 1977 - MAY 1988

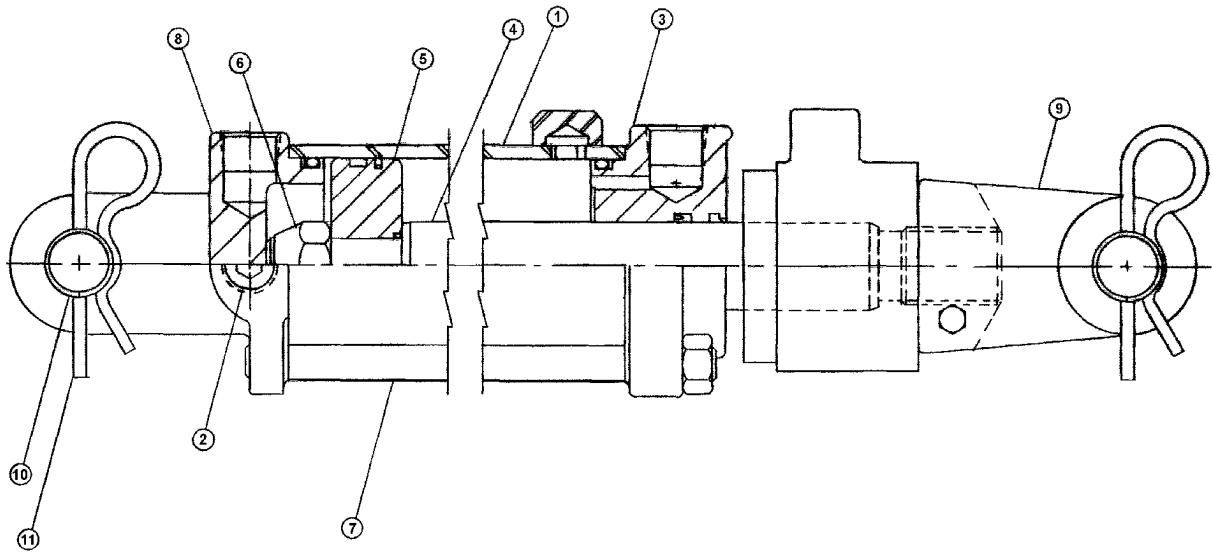

ITEM	PART NO.	QTY.	DESCRIPTION
	0652141300	-	HYD CYL KIT
1	0652141301	1	PISTON ROD
2	0652141312	1	PLUG, STRAIGHT ADAPTER
3	0652141302	1	TUBE
4	0652141303	1	HEAD
5	0652141304	1	PISTON
6	6511320	1	NUT, PISTON (3/4-NF HEX)
7	0652140305	4	TIEROD, HYD CYL W/NUT
8	0652141306	1	BASE CLEVIS
9	0652140307	1	CLEVIS, ROD
10	691356	2	PIN
11	37107B13	4	CLIP-X HAIR PIN
12	691302	1	HYD HOSE-3/8-8W/ 1/2FITTING (NOT SHOWN)
13	B651302	1	HOSE #6 - 8MP - 8MP - 180LG (NOT SHOWN)
14	6513015	1	HOSE #6 - 8 MP - 8 MP 216 LG (NOT SHOWN)
15	B65113A2	1	HYD HOSE ONE (NOT SHOWN)
16	94514	6	ADAPTER, HYD, ELBOW SWIVEL (NOT SHOWN)

Note; Center Cylinder has stroke control (Item 13) on shaft. The unit must already have hydraulic cylinders to fit arms and deck.

CYLINDER ASSEMBLY - LEVEL LIFT REPLACEMENT ASSY (P/N 8719) S/N 00101 - 10429 OCT 1977 - MA

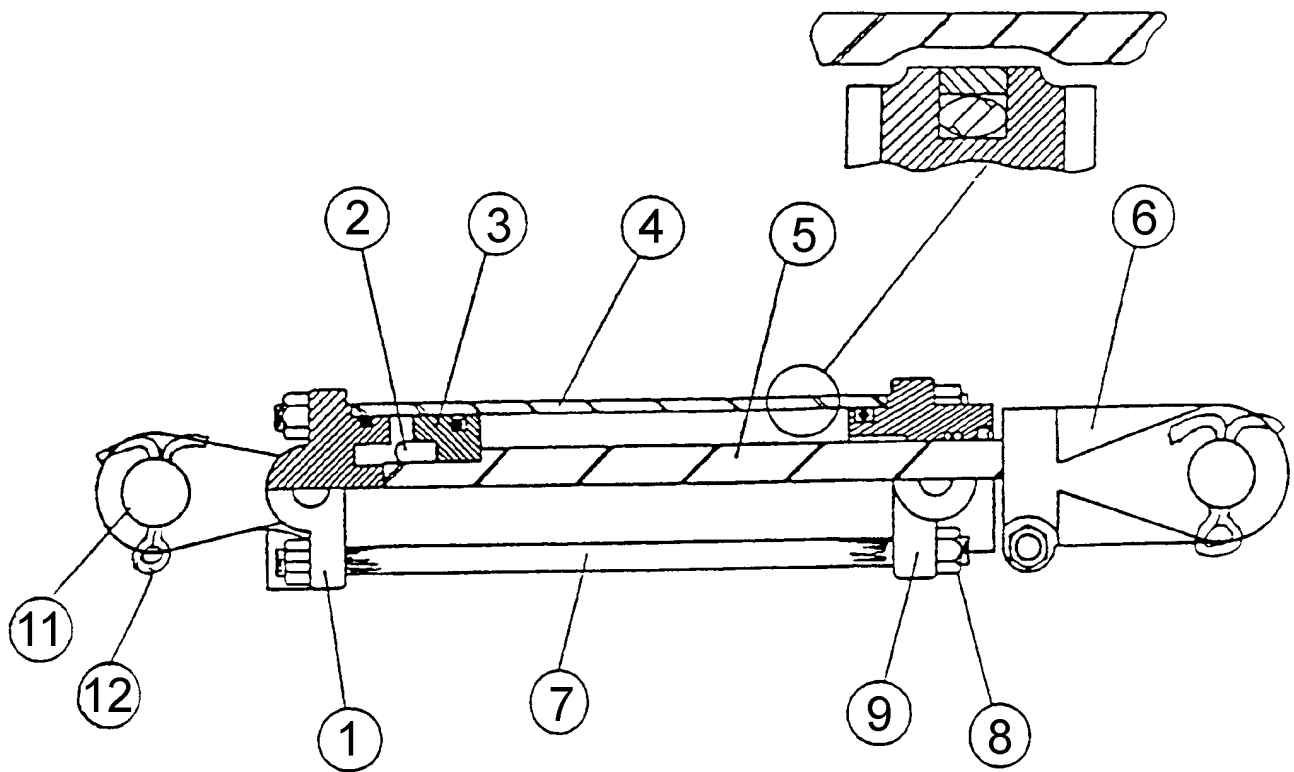

ITEM	PART NO.	QTY.	DESCRIPTION
	8719	1	HYDRAULIC CYLINDER
1	8772	1	CAP
2	4705M	1	PISTON NUT
3	8768	1	PISTON
4	8769	1	TUBE
5	4706	1	PISTON ROD
6	8754	1	CLEVIS, OUTER
7	8773	4	TIE ROD
8	4689	8	NUT HEX 9/16-18NF PL
9	8774	1	HEAD
10	8764	1	SEAL KIT
11	8354	2	PIN-HYD. CYLINDER
12	163016	4	PIN, COTTER 3/16 X 2
?13	00755234	1	CONTROL SPACER KIT (NOT SHOWN.)

Note: Center cylinder WILL NOT have screw on stroke control. The unit must already have hydraulic level left for these cylinders it mount to axle arms and deck.

REPLACE CYL'S ONLY NOT USED IN PRODUCTION UNIT, PARTS WILL NOT INTERCHANE WITH EARLIER CYLINDERS.

CYLINDER ASSEMBLY - LEVEL LIFT REPLACEMENT ASSY (P/N 8720) S/N 00101 - 10429 OCT 1977 - MA

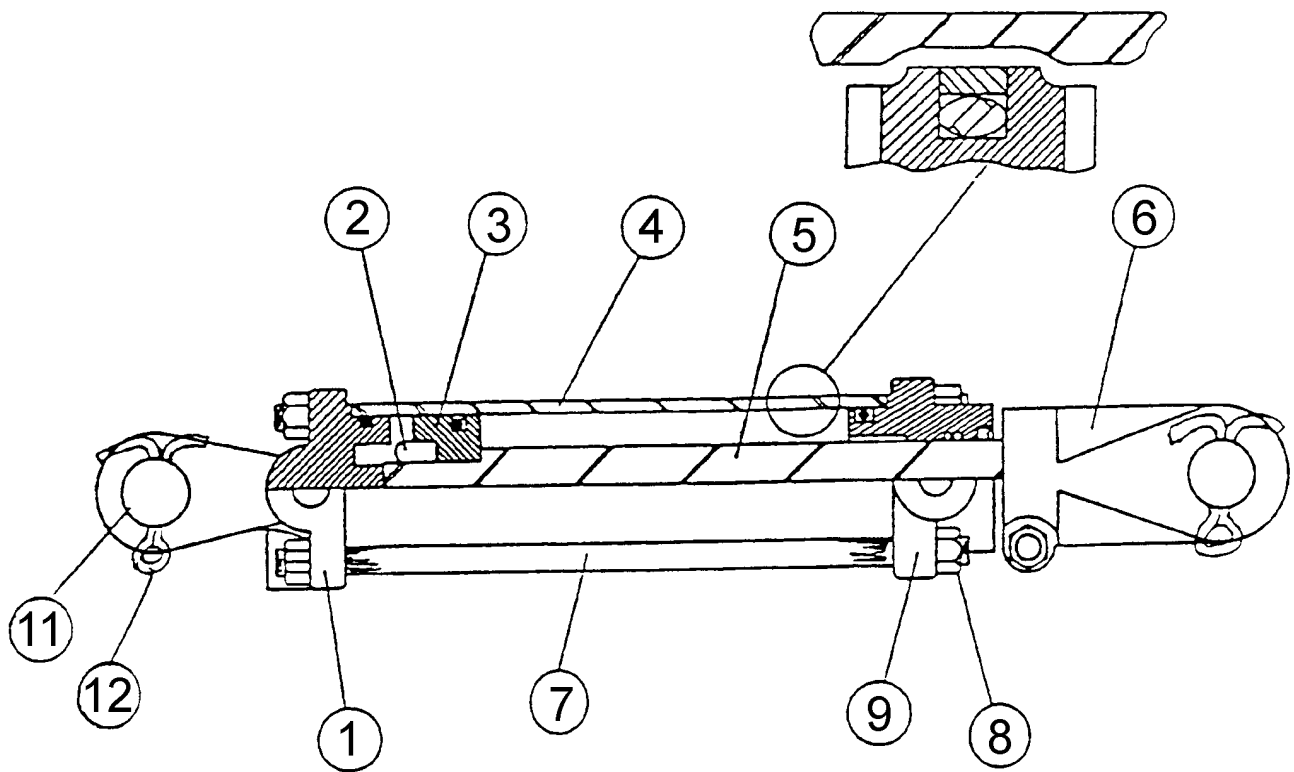

ITEM	PART NO.	QTY.	DESCRIPTION
	8720	-	WING AXLE 3 1/4 X 8 SLAVE CYLINDER
1	8778	1	BASE CLEVIS
2	4705	1	PISTON NUT
3	8775	1	PISTON
4	8776	1	TUBE
5	4706	1	PISTON ROD
6	8754	1	ROD CLEVIS
7	8773	4	TIE ROD
8	4689	8	NUT 9/16 - 18
9	8779	1	HEAD
10	8765	1	SEAL KIT
11	8354	2	PIN, CLEVIS
12	163016	4	COTTER PIN

Note: Center cylinder WILL NOT have screw on stroke control. The unit must already have hydraulic level left for these cylinders it mount to axle arms and deck.

REPLACE CYL'S ONLY NOT USED IN PRODUCTION UNIT, PARTS WILL NOT INTERCHANE WITH EARLIER CYLINDERS.

CYLINDER ASSEMBLY - LEVEL LIFT REPLACEMENT ASSY (P/N 8721) S/N 00101 - 10429 OCT 1977 - MA

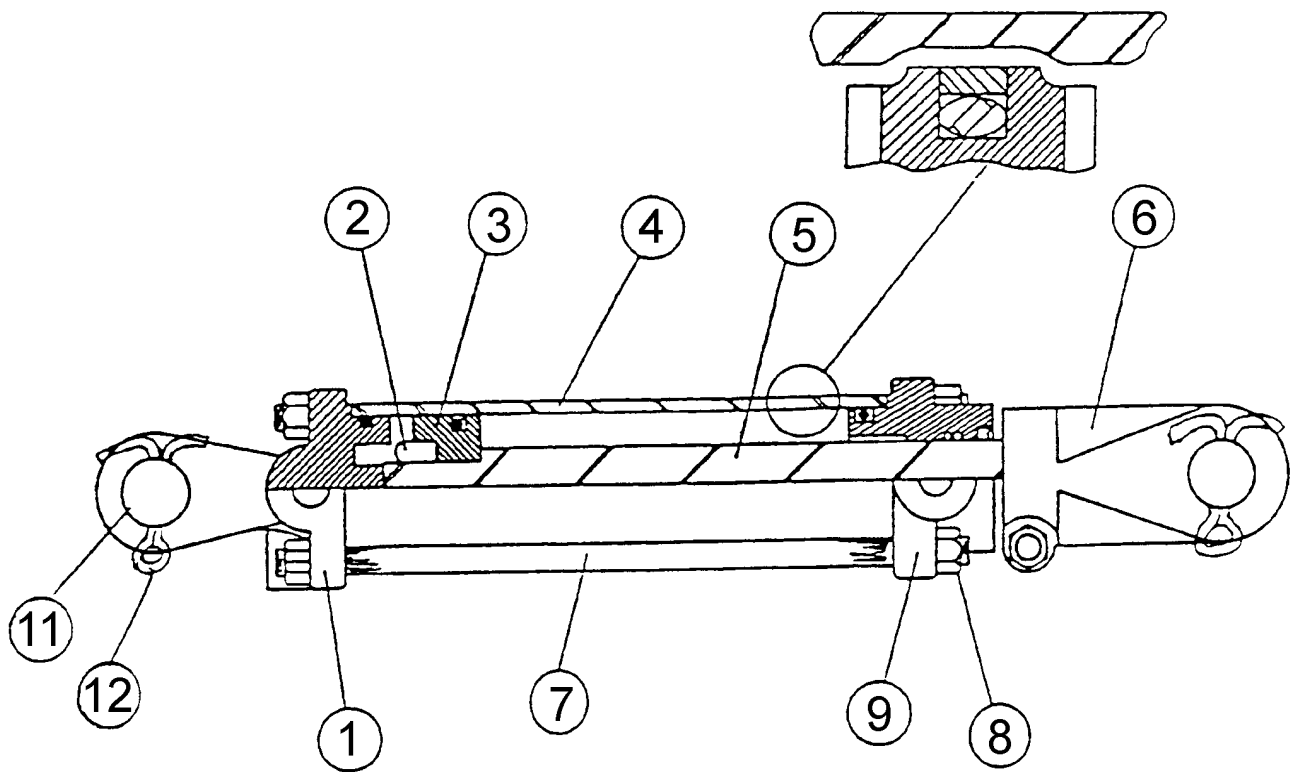

ITEM	PART NO.	QTY.	DESCRIPTION
	8721	1	CYL HYD LEVEL LIFT 3 DIA
1	8784	1	CAP (HYD. CYLINDER)
2	4675M	1	NUT PISTON
3	8780	1	PISTON
4	8781	1	TUBE
5	8753	1	PISTON ROD
6	8754	1	CLEVIS, OUTER
7	8785	4	TIE ROD
8	4376	8	NUT HEX 1/2-20 NF PL
9	8786	1	HEAD
10	8766	1	SEAL KIT
11	8354	2	PIN-HYD. CYLINDER
12	163016	4	PIN, COTTER 3/16 X 2

Note: Center cylinder WILL NOT have screw on stroke control. The unit must already have hydraulic level left for these cylinders it mount to axle arms and deck.

REPLACE CYL'S ONLY NOT USED IN PRODUCTION UNIT, PARTS WILL NOT INTERCHANE WITH EARLIER CYLINDERS.

CYLINDER ASSEMBLY - WING-HYDRAULIC CYLINDER & HOSE GROUP S/N 00101 - 01376 OCT 1977 - JAN

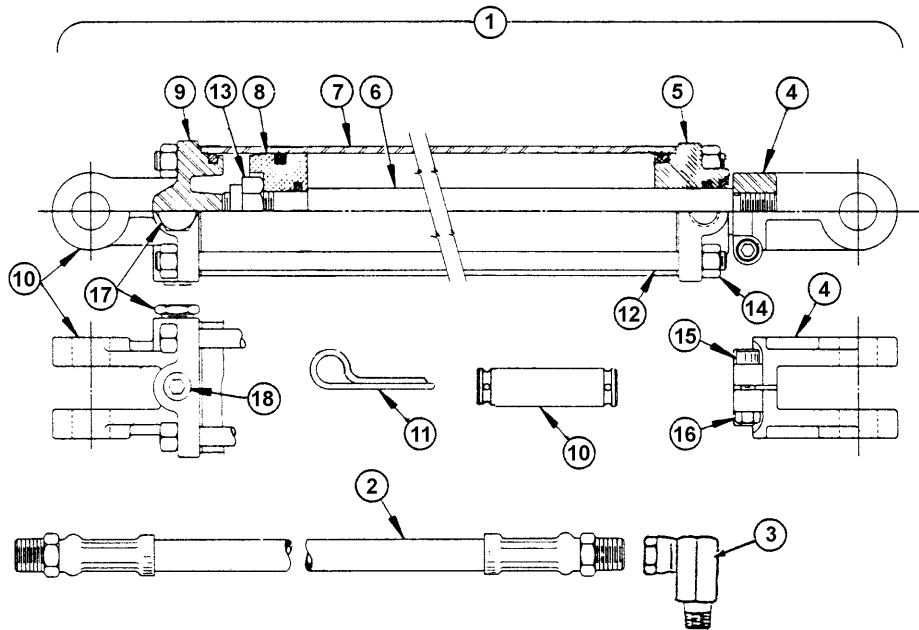

ITEM	PART NO.	QTY.	DESCRIPTION
1	00759947	1	CYLINDER 3 X 14 W/1-1/4 ROD
2	6513015	1	HOSE #6 - 8 MP - 8 MP 216 LG
3	94514	1	ADAPTER, HYD, ELBOW SWIVEL
4	691351	2	NUT
	65130A12	1	CLEVIS 1 1/8-12 NF THD
5	65113B8	1	HEAD 1 1/4 ROD 3 BR
	65130A4	1	HEAD 3 BORE X 1-1/8 ROD
	65130A4	1	HEAD 3 BORE X 1-1/8 ROD
6	65130B15	1	ROD,CYL 1-1/4 DIA,1-1/4-12 THD
	651306	1	ROD
7	651307	1	TUBE OUTBOARD
8	691315	1	PISTON, 3, O RING SEAL
	6511311	1	PISTON, 3, UCUP SEAL
9	65113A12	1	CLEVIS BASE 1/2
	0651130001	1	CLEVIS BASE 7/16
10	8354	2	PIN-HYD. CYLINDER
11	00000400	4	PIN-COTTER 1/8 X 1-1/2 PLATED
12	65130A8	4	TIE ROD 1/2 X 19
	0651300003	4	ROD
13	6511320	1	NUT, PISTON (3/4-NF HEX)
14	00001200	8	NUT,HEX 1/2 NC PL
	5B7140	8	NUT 7/16 NC HEX
15	6511322	1	BOLT
16	00013901	1	NUT HEX 3/8 NC PL
17	00750208	1	PLUG,BREATHER 1/2 NPTM - 007
18	00749508	1	PLUG 1/2-14 NPT
	65113A30	-	SEAL KIT 3 CR CYL, 1 1/4
	6513011A	-	SEAL KIT,3 CROSS CYLINDER 1 1/8

Note: This cylinder used throught approx 1982. Check length of barrel before ordering replacement pars. If the cylinder was used check size of tie rods (Item #12) and size of cylinder rod (Item #6).

REPLACEMENT PARTS FOR THIS COMPLETE CYLINDER ASSY IS 00759947.

PARTS WILL NOT INTERCHANGE.

CYLINDER ASSEMBLY - WING-LANTEX HYDRAULIC CYL & HOSE GRP S/N 01377 - 10429 JAN 1982 - MAY

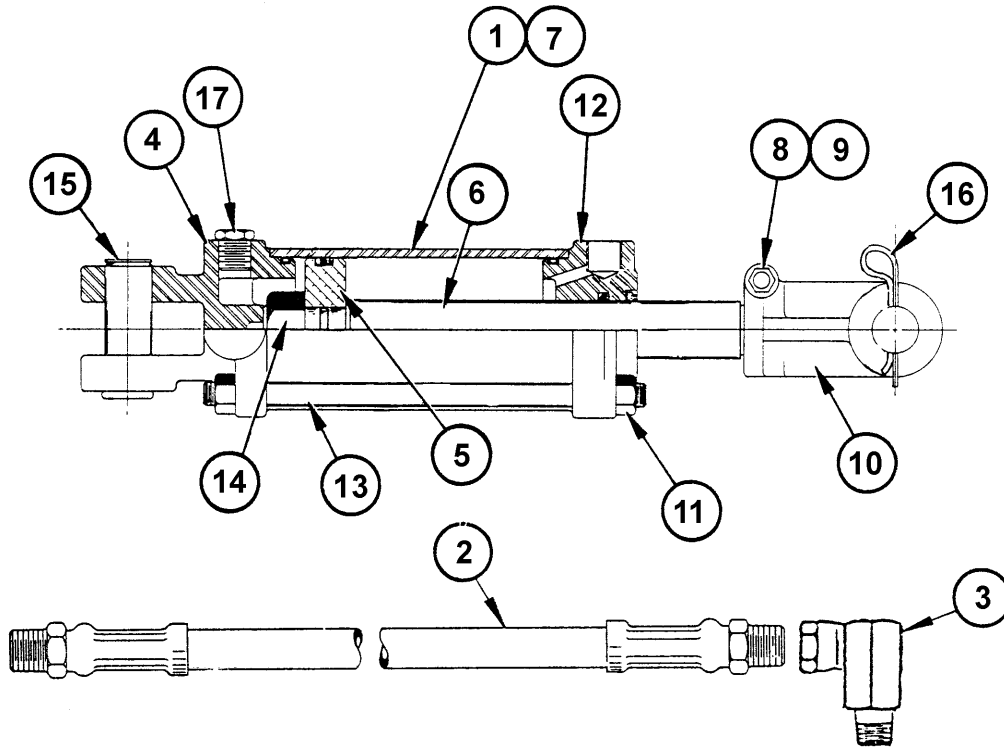

ITEM	PART NO.	QTY.	DESCRIPTION
1	65130B1	1	HYD. CYL. 3" BORE X 14" STROKE 1-1/4" DIA. ROD BASE END
2	6513015	1	HOSE #6 - 8 MP - 8 MP 216 LG
3	94514	1	ADAPTER, HYD, ELBOW SWIVEL
4	0651130001	1	CLEVIS BASE
5	0651130005	1	PISTON
6	0651300001	1	ROD
7	0651300002	1	TUBE
8	5B6240	1	NUT, ROD CLEVIS
9	7E62414	1	SHCS 3/8 NF 1-3/4
10	0651130022	1	CLEVIS 1-14 NF THD
11	02816800	8	NUT 1/2 NF HEX
12	0651130016	1	HEAD 3 HYD CYL 1-1/4 ROD
13	0651300003	4	ROD
14	691351	1	NUT
15	8354	2	PIN-HYD. CYLINDER
16	00000400	4	PIN-COTTER 1/8 X 1-1/2 PLATED
17	00750208	1	PLUG, BREATHER 1/2 NPTM - 007
	0651130014	-	SEAL KIT, 3 LANTEX CYLINDER

Note: This cylinder used approx. After 1982 always check barrel length (Item #7) before ordering replacement parts.
 REPLACE THIS CYLINDER ASSY WITH #00759947.
 PARTS WILL NOT INTERCHANGE.

CYLINDER ASSEMBLY - WING-REPLACEMENT S/N 00101 - 10429 OCT 1977 - MAY 1988

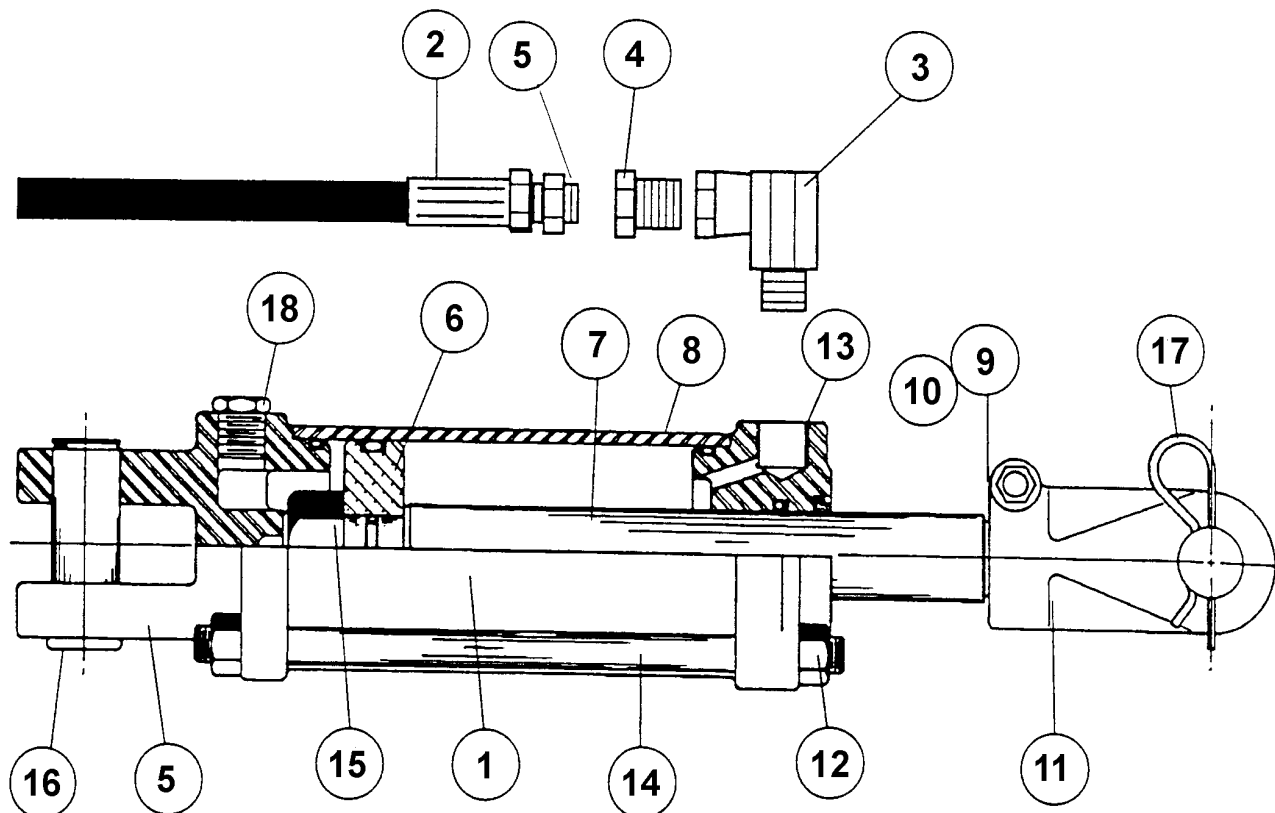

ITEM	PART NO.	QTY.	DESCRIPTION
1	00759947	1	CYLINDER 3 X 14 W/1-1/4 ROD
2	00756496	1	HOSE-#4-6MP-6MP-216LG
3	94517	1	ADAPTER, HYD, ELBOW SWIVEL
4	7329	1	ADAPTER, HYD, STGHT RESTRICTOR
5	94507	1	ADAPTER, HYD, REDUCER
5	00760196	1	BASE, CYL 3
6	00760198	1	PISTON
7	00760201	1	ROD, CYL 3X14
8	00760195	1	TUBE, CYL 3X14
9	00013901	1	NUT HEX 3/8 NC PL
10	00023100	1	HHCS 3/8 -16UNC 1-1/2 PL5
11	8754	1	CLEVIS, OUTER
12	4690W	8	INSTALL SHEET-BELT TENSIONER&S
13	00760197	1	HEAD, CYL 3
14	00760203	4	TIE ROD, CYL 3X14
15	4675M	1	NUT PISTON
16	8354	2	PIN-HYD. CYLINDER
17	162012	2	PIN, COTTER
18	6511324	1	BREATHER, 1/2 SQ HD CORED
?19	00760199		SEAL KIT (3 DIA HYD CYL)

Note: This is a replcaement cylinder and was not used in production.
PARTS WILL NOT INTERCHANGE WITH EARLIER CYLINDERS.

DECALS S/N 00101 - 10429 OCT 1977 - MAY 1988

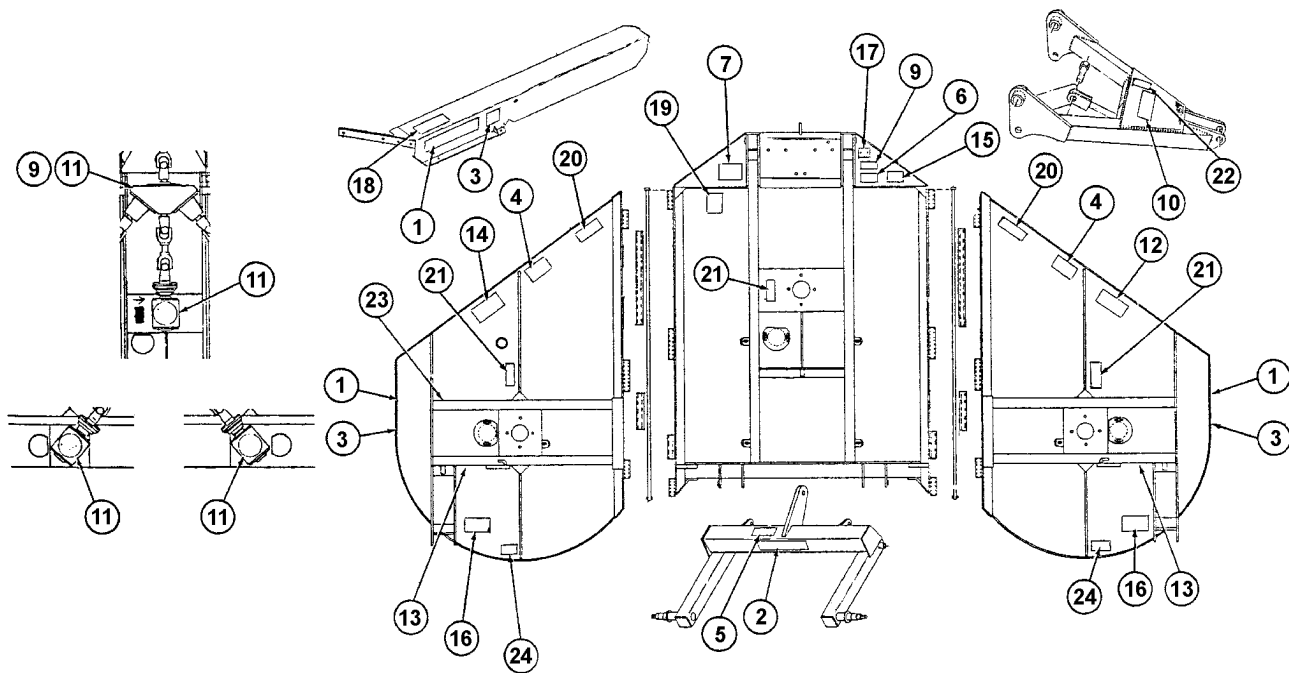

ITEM	PART NO.	QTY.	DESCRIPTION
1	D303	3	DECAL,RHINO
2	D301	1	DECAL,RHINO
3	D337	3	DECAL-FLX-S-15
5	D121	1	DECAL ADJ-NUTS
6	D122	1	DECAL(PREV. STREAKNG)
7	999200	1	DECAL GENERAL WARNING ALL UNIT
8	D112	1	DECAL USE SAE GER LUB
9	D103	1	DECAL,OPERATE AT 540 RPM
10	D102	1	DECAL PTO SFT TO HTCH
11	D101A	4	DECAL OIL LEVEL
12	D137	1	DECAL CCW BLADE ROTATION
13	99203	2	DECAL, RED REFLECTOR
14	D138	1	DECAL-CW BLADE ROTATION
15	D131	1	DECAL NOTICE
16	D304	2	DECAL (RHINO)
17	NFS	1	SERIAL NUMBER PLATE
18	999403	1	DECAL-DANGER, OFFSET WGT. BOX
21	00756494	3	DECAL-DANGER,DRIVELINE
23	99204	1	DECAL-YELLOW REFLECTOR
24	999401	2	DECAL, ROTATING BLADE
	26E127001	A/R	PAINT,1 QT,RH ORANGE
	26E127004	A/R	PAINT, 1 GAL,RH ORNG
	26E127000	A/R	PAINT,(SPRAY)RHINO ORANGE

DEFLECTOR - REAR WING S/N 01497 - 10429 JUN 1982 - MAY 1988

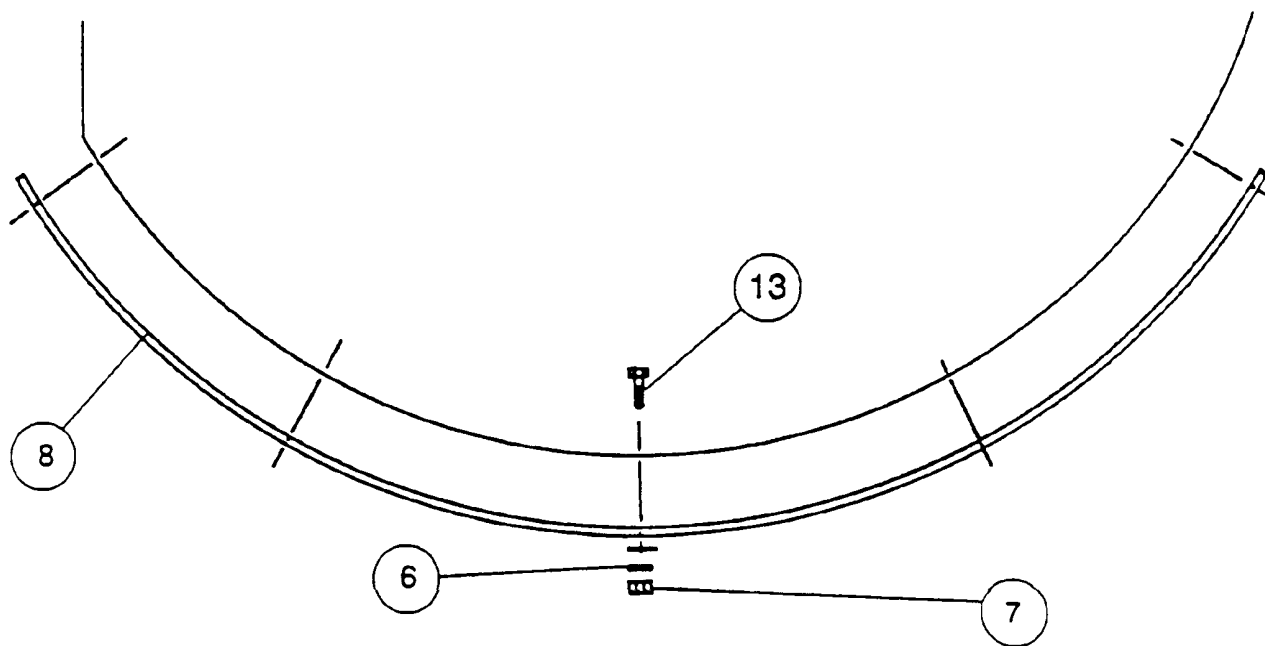

ITEM	PART NO.	QTY.	DESCRIPTION
6	00002700	10	FLATWASHER 1/2 PL STD
7	00001800	10	LOCKNUT TLM 1/2 NC PLB
8	00756876	2	WING REAR COVER
13	02030700	7	HHCS 1/2-13UNC 1-1/4 PL5

DEFLECTOR - RUBBER FRONT CENTER S/N 00101 - 10429 OCT 1977 - MAY 1988

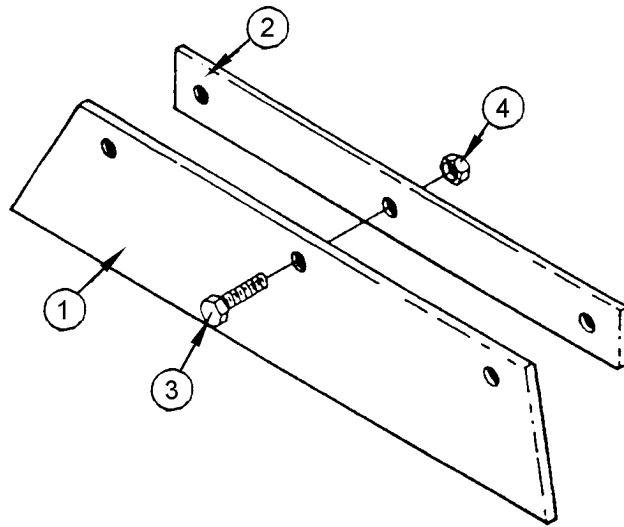

ITEM	PART NO.	QTY.	DESCRIPTION
	00758370	1	DEFLECTOR, ASY, FRT CTR
1	00758261	1	BAND RUBBER GD FRT CTR
2	00758263	1	PANEL RUBBER GD FRT CTR
3	02030700	3	HHCS 1/2-13UNC 1-1/4 PL5
4	00001800	3	LOCKNUT TLM 1/2 NC PLB

Note: These will not fit earlier serial numbers. Complete of deflectors front-center, left and right wings assembly #00758355.

For 10 foot unit order assembly #00756994.

DEFLECTOR - RUBBER FRONT WING LEFT & RIGHT S/N 00101 - 10429 OCT 1977 - MAY 1988

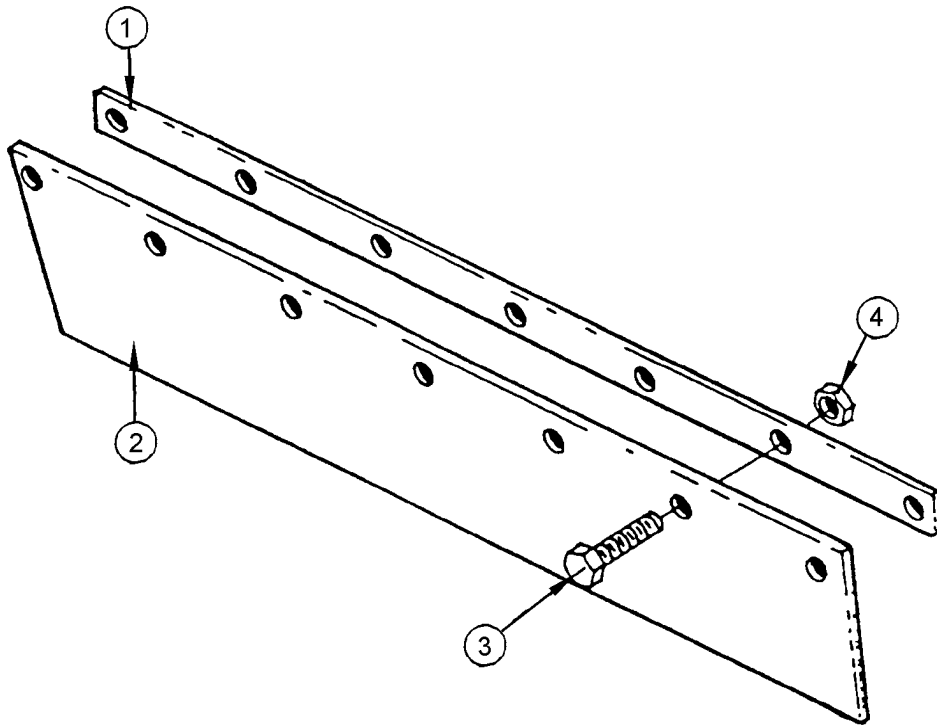

ITEM	PART NO.	QTY.	DESCRIPTION
	00758368	1	DEFLECTOR ASSEMBLY
1	00758264	1	PANEL
2	00758259	1	BAND
3	02030700	7	HEX BOLT
4	00001800	7	LOCKNUT

DEFLECTOR - RUBBER LEFT & RIGHT CENTER S/N 00101 - 10429 OCT 1977 - MAY 1988

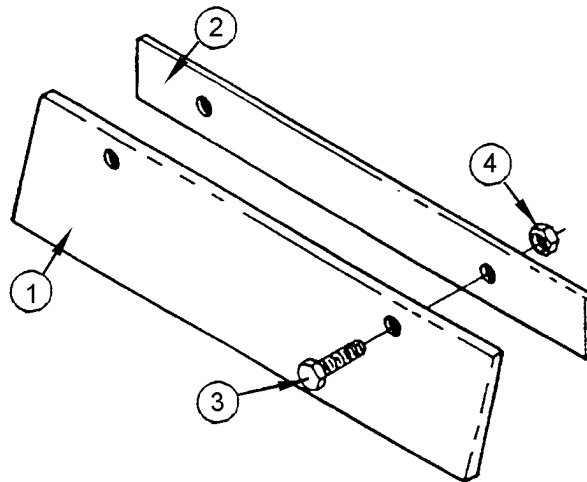

ITEM	PART NO.	QTY.	DESCRIPTION
	00758369	1	DEFLECTOR, ASY, FRT L-R CTR
1	00758262	1	PANEL RUBBER GD L&R CTR
2	00758260	1	BAND, RUBBER GD LH & RH
3	02030700	2	HHCS 1/2-13UNC 1-1/4 PL5
4	00001800	2	LOCKNUT TLM 1/2 NC PLB

Note: These will not fit earlier serial numbers. Complete of deflectors front-center, left and right wings assembly #00758355.

For 10 foot unit order assembly #00756994.

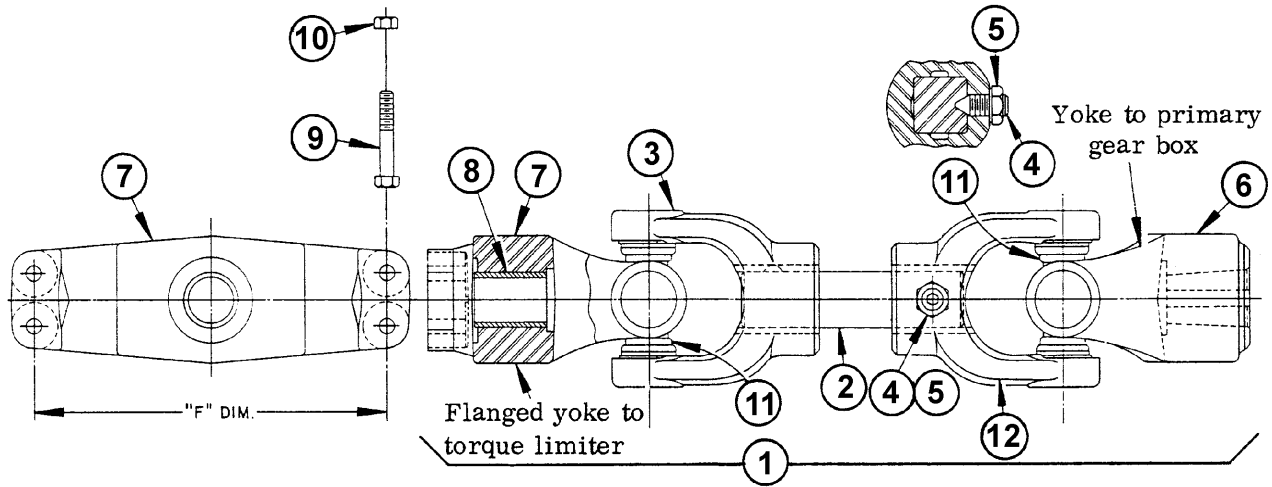

ITEM	PART NO.	QTY.	DESCRIPTION
1	0657070000	1	DRIVELINE, SLIP ASSY
	W707LSA	1	CTR D/L,S15,
2	W341	1	SHAFT SQ
3	W324	1	YOKE 1 3/16 SQ HOLE PAINT BLK
4	9C482010	1	SHSS 1/2 NF 1-1/4
5	5B8200	1	NUT 1/2 NF HEX
6	W318	1	YOKE W/TAPERED SHAFT PAINT BLK
	W284A	1	YOKE,SLIDE COLLAR PAINT BLACK
7	W3071	1	YOKE, TORQUE LIMITER (7-1/16
8	271105B	1	BUSHING SP & TL YOKE
9	7AH551816	4	HEXB 5/16NC 2
10	5JRC5180	4	NUT TOPLOCK 5/16
11	W279R	2	CROSS REPAIR KIT, CTR
12	W324A	1	YOKE,1-3/16 SQ HOLE W/SETScrew

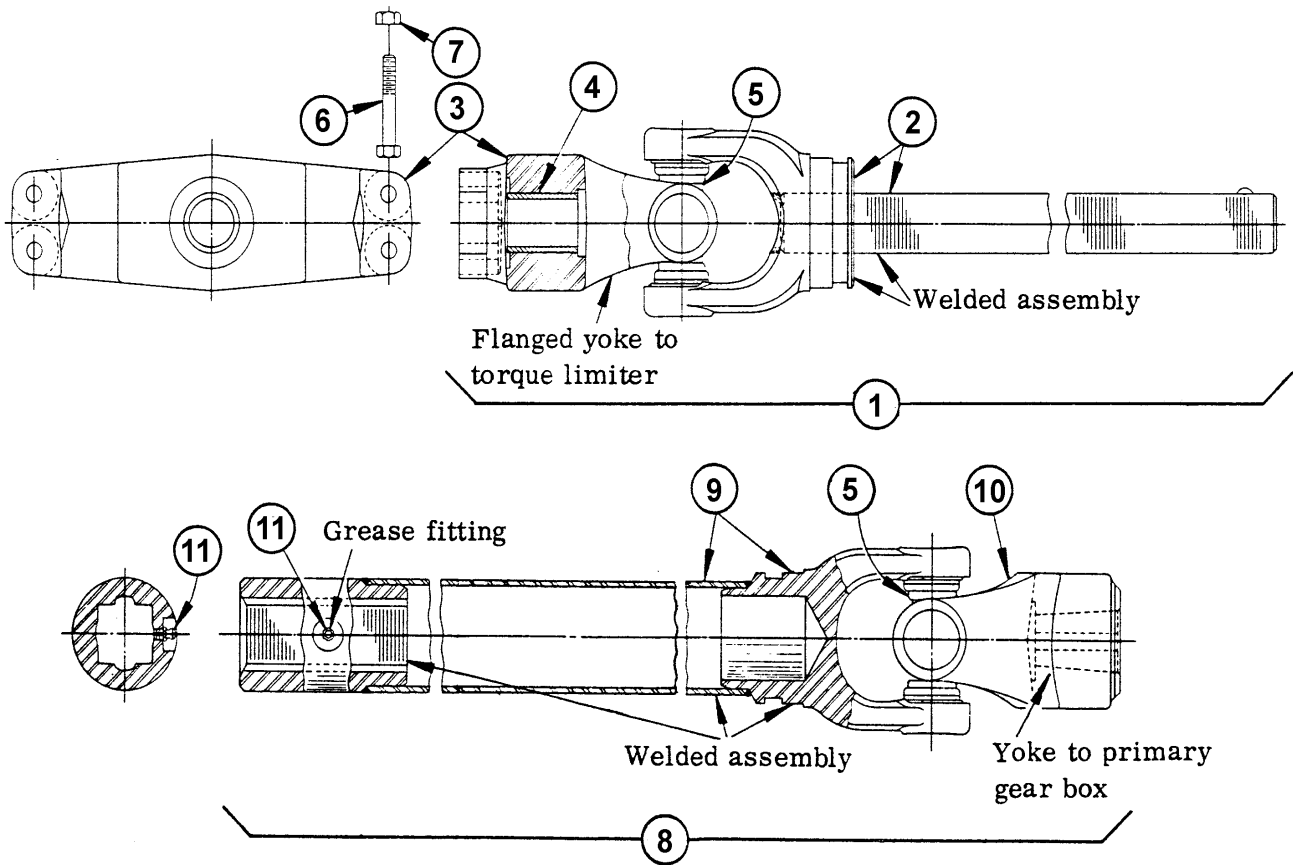

ITEM	PART NO.	QTY.	DESCRIPTION
1	W705RB7	1	SHFT, SHLD, SM TL YK
2	W316B	1	YK & SHFT ASSY 39-1/8
3	W3071	1	YOKE, TORQUE LIMITER (7-1/16)
4	271105B	1	BUSHING SP & TL YOKE
5	W279R	1	CROSS REPAIR KIT, CTR
6	7AH551816	4	HEXB 5/16NC 2
7	5JRC5180	4	NUT TOPLOCK 5/16
8	W702RZ4	1	HSG, SHLD, TPR YOKE
	W702RZ	1	HSG, SHLD, QD YOKE
9	W312Z	1	YOKE TB & SLV 50
10	W318	1	YOKE W/TAPERED SHAFT PAINT BLK
	W284A	1	YOKE, SLIDE COLLAR PAINT BLACK
11	17C1981	1	GREASE ZERK

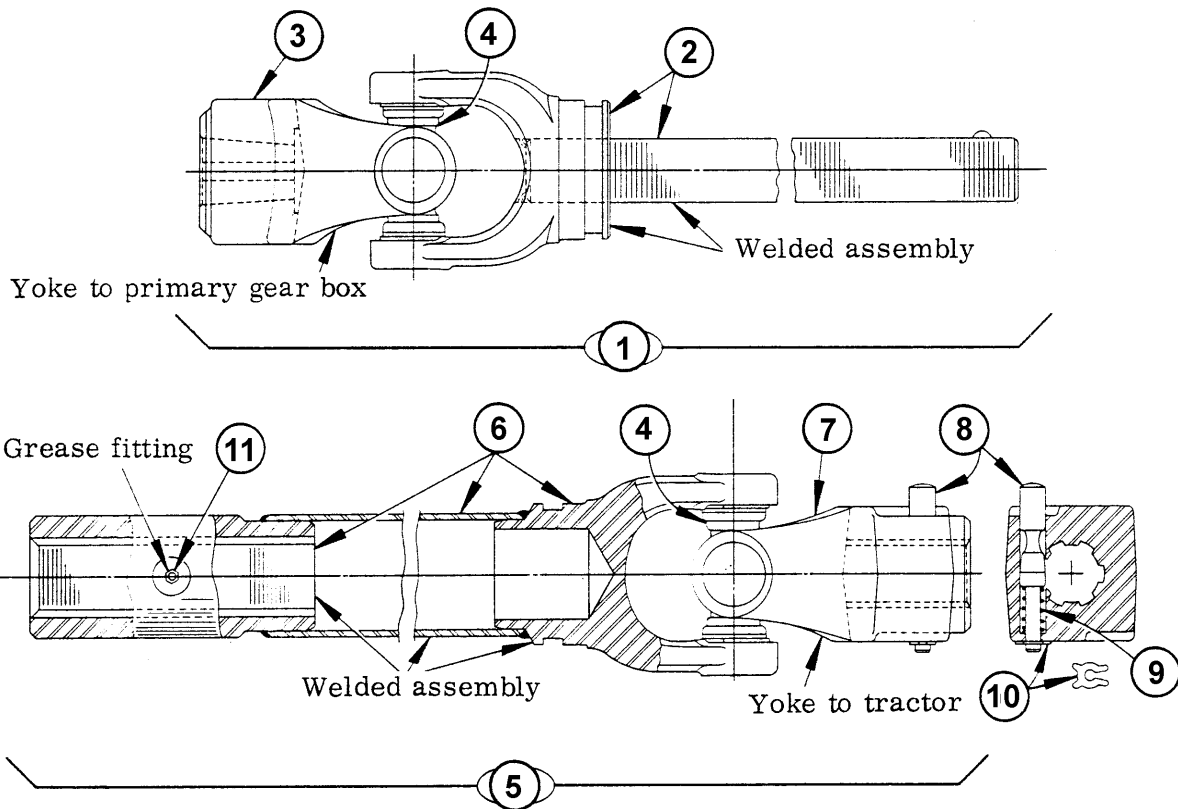

ITEM	PART NO.	QTY.	DESCRIPTION
1	W805O4	1	SHFT, SHLD,TPR YK PAINT BLACK
	W805O11	1	SHAFT 44R SQ ASY 1-3/4-20 SPL
2	W816A	1	YOKE SHAFT PAINT BLACK
3	W826	1	YOKE,SAE TAPER PAINT BLACK
	W827A	1	YOKE,CLP,1-3/4-20SP PAINT BLK
4	W840	1	CROSS REPR KIT
5	W802B	1	HSG,SHLD,QD YK PAINT BLACK
6	W812A	1	YOKE SLEEVE PAINT BLACK
7	W821A	1	YOKE,Q.D. 6BSPLN PAINT BLACK
8	W44B2A	1	QD REPAIR KIT
9	W44B3	1	SPRING-PIN LOCK
10	W44B4A	1	WASHER X
11	17C1981	1	GREASE ZERK

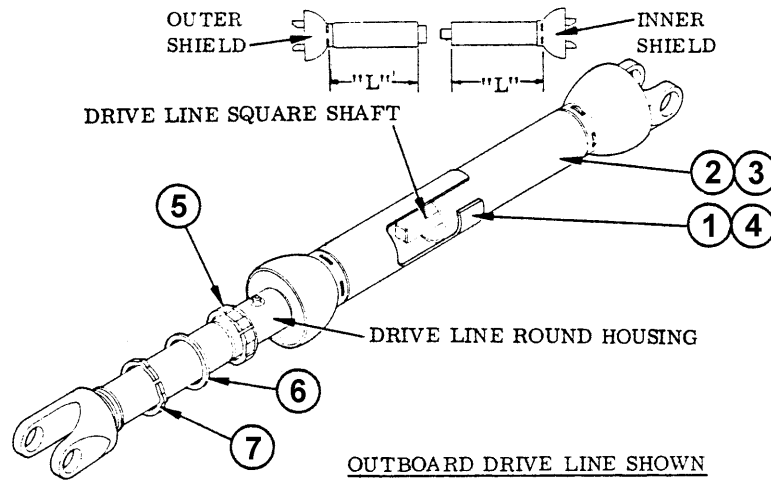

ITEM	PART NO.	QTY.	DESCRIPTION
1	W811Q	AR	SHIELD D/L OUTER PAINT BLACK
	W815R	AR	SHLD IN ASSY PAINT BLACK
2	W315RA1	AR	SHIELD ASSY, INNER
4	W311RZ1	AR	SHIELD, OUTER
5	W335	AR	BEARING, NYLON
	00751176	AR	RETAINER, NYLON BRG.
6	W936	AR	WASHER THRUST
7	W937	AR	RING SNAP

NOTES

GEARBOX ASSEMBLY - CENTER SECTION S/N 00101 - 10429 OCT 1977 - MAY 1988

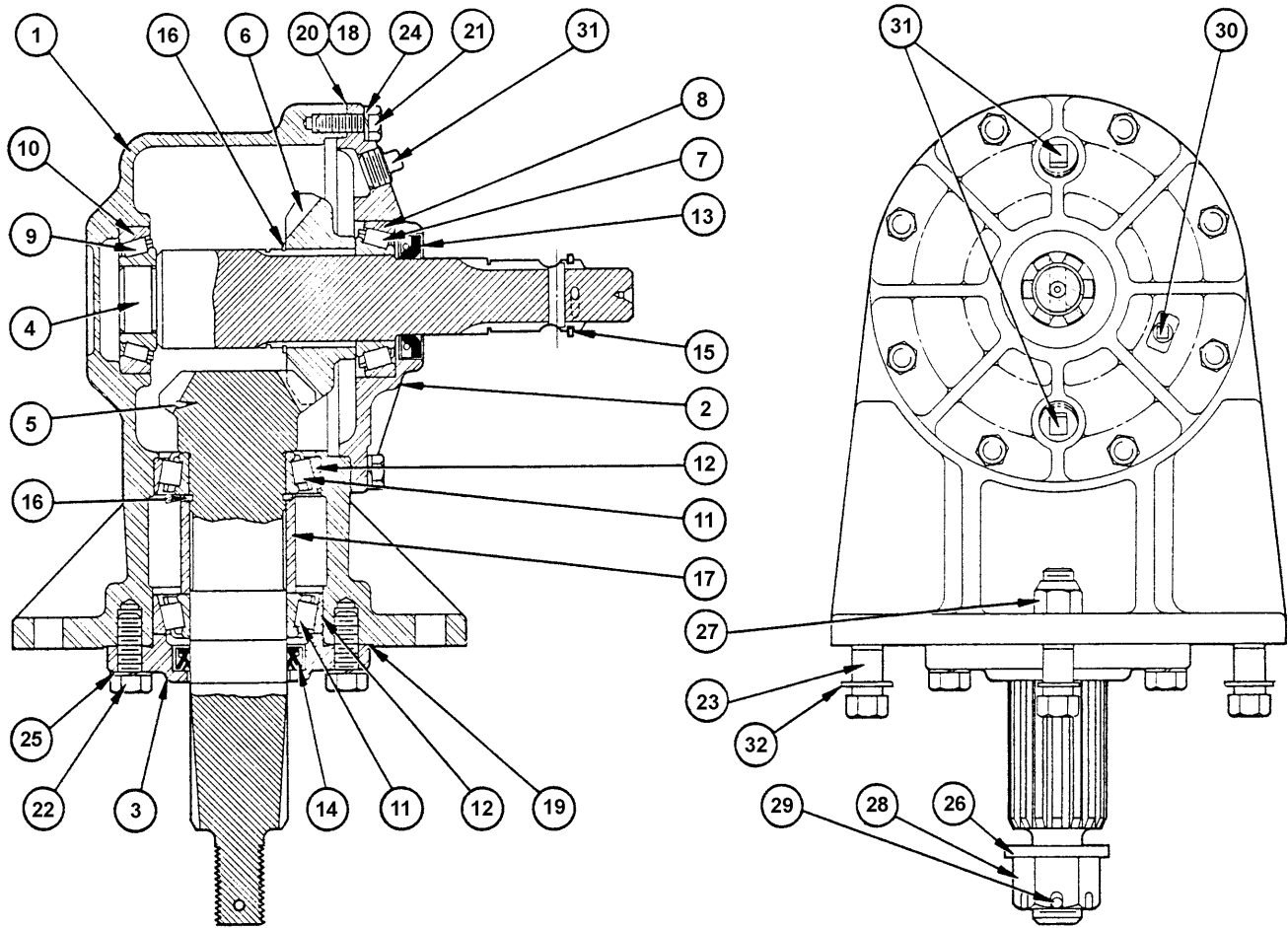

GEARBOX ASSEMBLY - CENTER SECTION S/N 00101 - 10429 OCT 1977 - MAY 1988

ITEM	PART NO.	QTY.	DESCRIPTION
1	7010414	1	HOUSING MAIN
2	00748532	1	HOUSING-BEARING CAP
3	00752155	1	CAP BEARING RETAINING
4	7010416	1	SHAFT, INPUT 1-3/8-6
5	701047R	1	OUTPUT SHAFT & GEAR
6	00752159	1	GEAR BEVEL-22 TOOTH
7	00748527	1	BEARING CONE TIMKEN #LM603049
8	00748525	1	BEARING CUP
9	00753738	1	BEARING CONE 16137
10	00753737	1	BEARING CUP 16282
11	00748522	2	BEARING CONE
12	701044R	2	BEARING CUP 363
13	00749509	1	SEAL
14	00748519	1	OIL SEAL
15	7010422	1	RING
16	00748526	2	RING, RETAINING
17	701046R	1	SPACER
18	00758647	A/R	SHIM, ADJUSTMENT .010 OR .25M
19	7010419	A/R	SHIM KIT
20	00758648	1	SHIM ,ADJUSTMENT O.5
21	00011400	8	HHCS 3/8 NC 1 PL5
22	02030700	4	HHCS 1/2-13UNC 1-1/4 PL5
23	7AH5121620	4	C/S 3/4 X 2 1/2 NF 5
24	00011700	8	LOCKWASHER 5/16 PL STD
25	00753743	4	LOCKWASHER
26	00748547	1	FLATWASHER 1-1/32 X 2-3/16X.22
27	00748539	4	NUT TOPLOCK 3/4 NF PLB
28	5E16140	1	NUT CASTLE 1 -14 STD PL
29	00606000	1	PIN-COTTER 3/16 X 2
30	00565000	1	PLUG, HEX HEAD PIPE 1/8-27NPT
31	00749508	2	PLUG 1/2-14 NPT
32	5312316	4	WASHER (SPECIAL)

NOTE: ITEM 15,23,27, & 32 NOT INCLUDED WITH GEARBOX ASSEMBLY AND MUST BE SPECIFIED WHEN ORDERING 701041 GEARBOX ASSEMBLY.

GEARBOX ASSEMBLY - DIVIDER (COMER) S/N 01901 - 10429 FEB 1985 - MAY 1988

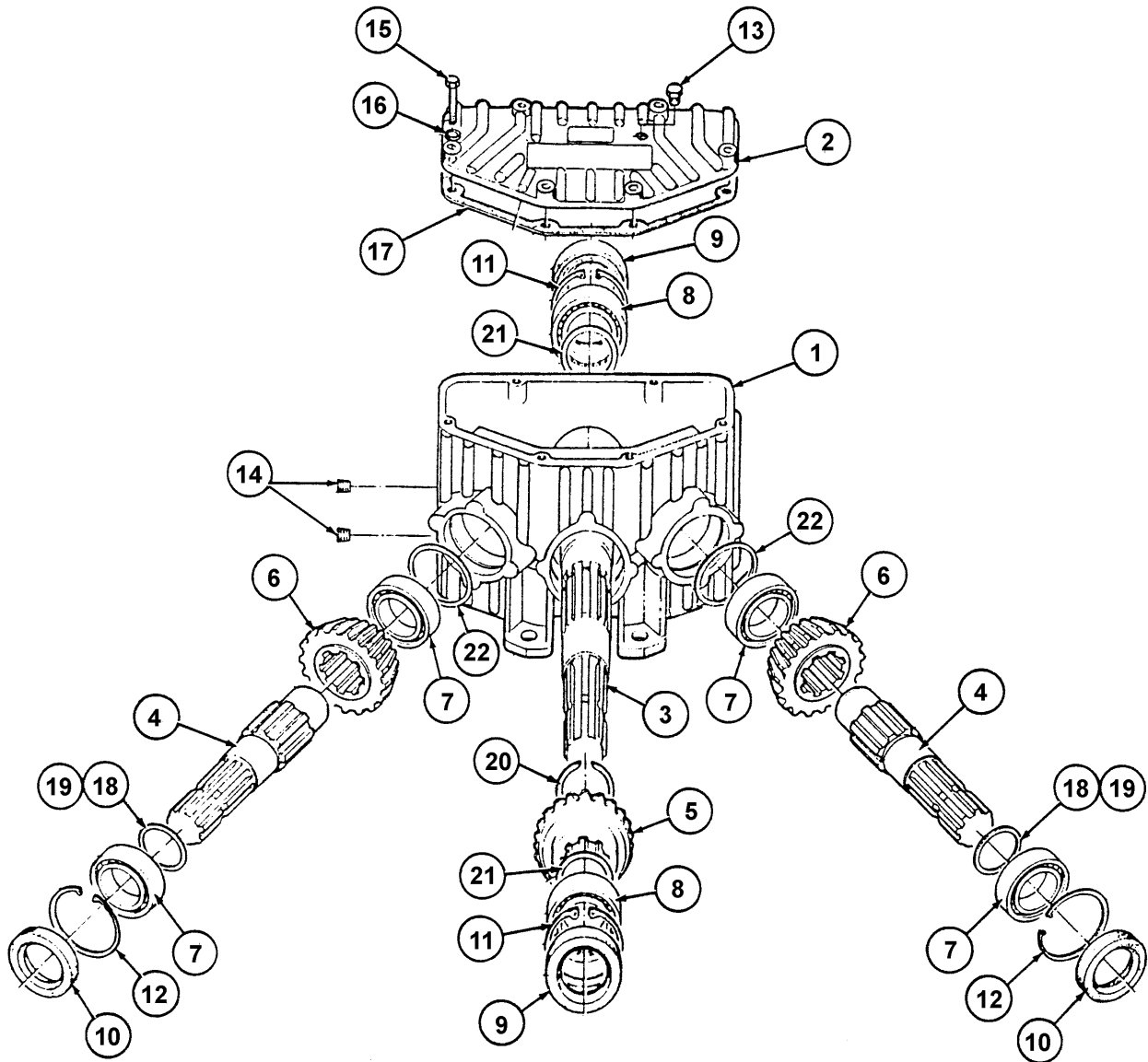

GEARBOX ASSEMBLY - DIVIDER (COMER) S/N 01901 - 10429 FEB 1985 - MAY 1988

ITEM	PART NO.	QTY.	DESCRIPTION
	0656030000		DIVIDER GEARBOX
1	00753232	1	CASING
2	00753240	1	COVER
3	00753233	1	SHAFT
4	00753221	2	SHAFT
5	00753234	1	CROWNWHEEL
6	00753228	2	BEVEL PINION
7	00753223	4	BEARING
8	00755070	2	BEARING
9	00753238	2	OIL SEAL
10	00753225	2	OIL SEAL
11	00753237	2	INTERNAL CIRCLIP
12	00753237	2	INTERNAL CIRCLIP
13	00753239	1	OIL FILLER PLUG
14	00753226	2	PLUG
15	00753230	6	HEXB METRIC 8-P1.25- 30MM PL5
16	00753231	6	SCHNORR WASHER
17	00755069	1	GASKET
19	00753222	2	SHIM
21	00753235	2	SHIM
22	00753227	2	TAKE-UP RING

NOTE: ITEMS 30 AND 31 ARE NOT FURNISHED WITH THE GEARBOX ASSEMBLY. THIS GEARBOX HAS 1 3/8 TAPER SHAFTS.

P/N 651033 GEAR REPLACE BY P/N 00757028.

Offset units used gearbox#0651030000 (same as #65103 except only on wing out put shaft) Cover #0682053, 6 bolts #0682053, 6 bolts #7A10118, & 6 lockwashers #131000.

GEARBOX ASSEMBLY - DIVIDER S/N 00101 - 01900 OCT 1977 - FEB 1985

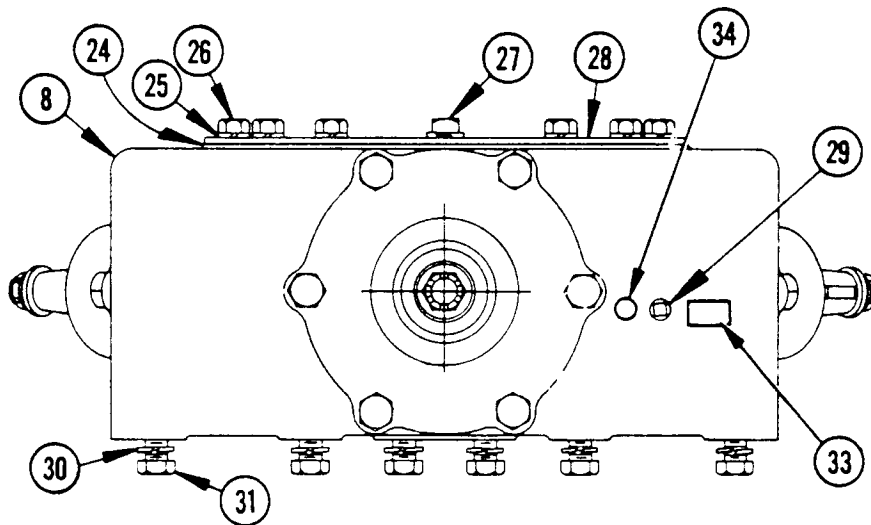
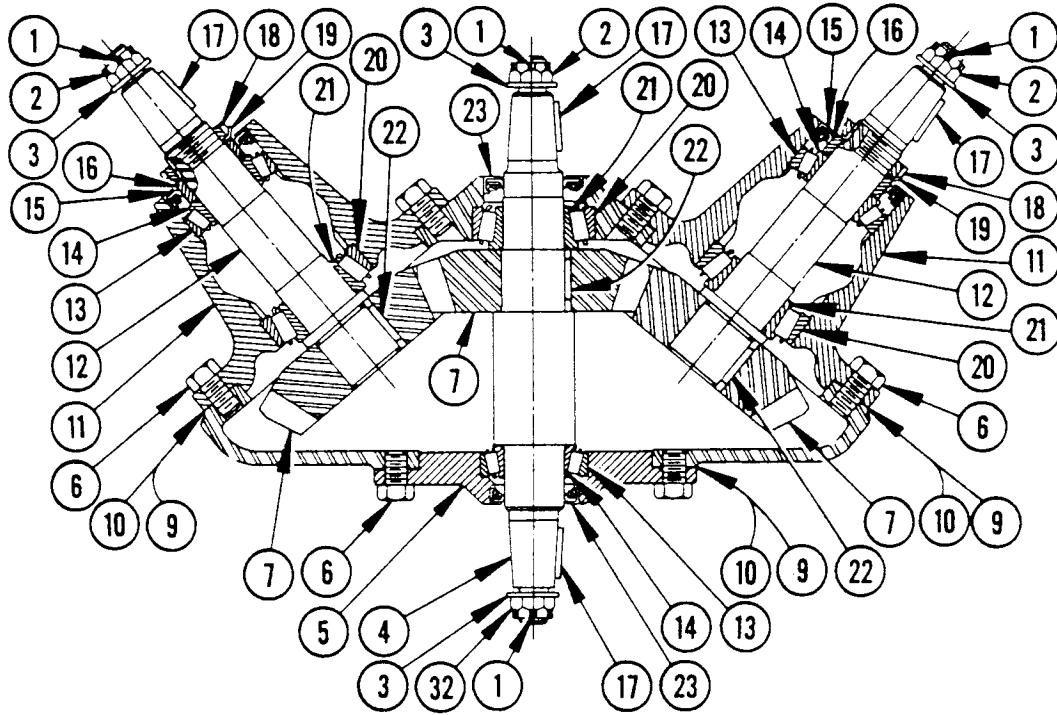

GEARBOX ASSEMBLY - DIVIDER S/N 00101 - 01900 OCT 1977 - FEB 1985

ITEM	PART NO.	QTY.	DESCRIPTION
	65103		GEARBOX ASSY
1	16212012	4	COTTER PIN
2	5312315	3	CASTE NUT (SPECIAL THIN)
3	5312316	4	SPECIAL WASHER (HEAT TREATED)
4	651035	1	INPUT SHAFT
5	651037	1	BEARING CARRIER CAP
6	7A1101110	18	PLACE BOLT
7	00757028	3	BEVEL GEAR, 18-TEETH
8	651031	1	PRIMARY GEAR BOX HOUSING
9	5312312	3	SHIM SET
10	PT204A	3	GASKET
11	531232	2	DRIVE SHAFT HOUSING
12	651036	2	OUTPUT SHAFT
13	W84	3	BEARING CUP
14	W83	3	BEARING CONE
15	PT103	2	OIL SEAL
16	271096	2	BEARING COLLAR
17	5312310	4	KEY (HEAT TREATED)
18	PT104	2	LOCKNUT
19	PT105	2	LOCKWASHER
20	531237	3	BEARING CUP
21	531238	3	BEARING CONE
22	PT209	3	WOODRUFF KEY
23	5310415	2	OIL SEAL
24	651034	1	GASKET
25	00001300	8	LOCKWASHER
26	00750959	8	CAPSCREW
27	301021	1	BREATHER PLUG
28	651032	1	GEAR BOX COVER PLATE
29	00751003	1	PIPE PLUG
30	00010300	6	LOCKWASHER
31	00752658	6	CAPSCREW
32	5DR12160	1	NUT
33	D112	1	DECAL (USE SAE GEAR LUBE)
34	D101A	1	DECAL (OIL LEVEL)

GEARBOX ASSEMBLY - LEFT WING S/N 00101 - 10429 OCT 1977 - MAY 1988

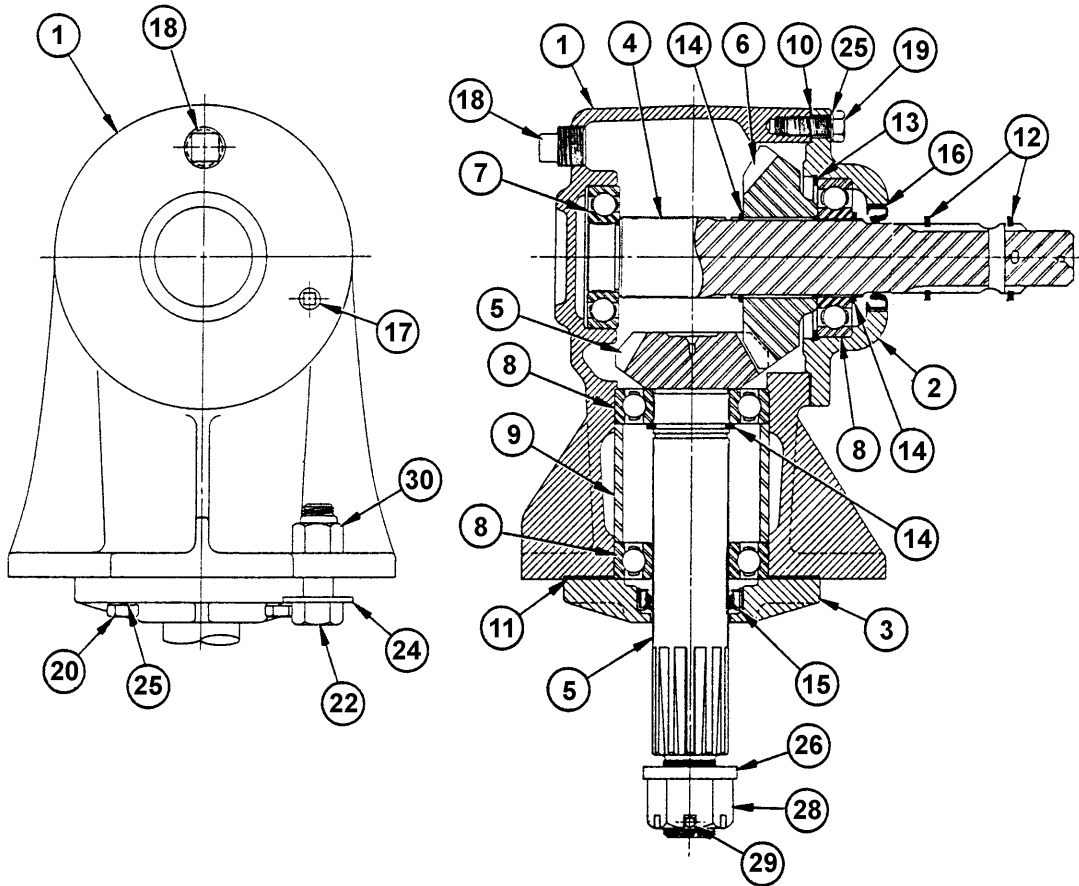

GEARBOX ASSEMBLY - LEFT WING S/N 00101 - 10429 OCT 1977 - MAY 1988

ITEM	PART NO.	QTY.	DESCRIPTION
	0656230000		GEARBOX
1	00563900	1	MAIN HOUSING
2	00564300	1	CAP, BEARING
3	711052	1	CAP W/SPACER
4	0656230001	1	SHAFT, 1-3/8-6 INPUT W/PILOT
5	00564000	1	PINION OUTPUT SHAFT
6	00564600	1	INPUT GEAR
7	00564800	1	BEARING, BALL
8	00563700	3	BEARING, BALL
9	00757682	1	SPACER, BEARING
10	00564400	A/R	SHIM
11	00563600	1	GASKET
12	00612703	2	SNAP-RETAINER RING
13	00564500	1	RING, RETAINING
14	00564100	3	RING, RETAINING
15	00563500	1	SEAL, OIL OUTPUT
16	00564200	1	OIL SEAL
17	00565000	1	PLUG, HEX HEAD PIPE 1/8-27NPT
18	00749508	1	PLUG 1/2-14 NPT
19	00011400	6	HHCS 3/8 NC 1 PL5
20	00753642	4	HHCS, 3/8NC X 1-1/4, ZP, GRD5
22	7AH5101816	4	C/S 5/8 X 2 NF GR5
24	W67	4	WASHER
25	00011700	10	LOCKWASHER 5/16 PL STD
26	00748547	1	FLATWASHER 1-1/32 X 2-3/16X.22
28	5E16140	1	NUT CASTLE 1 -14 STD PL
29	00606000	1	PIN-COTTER 3/16 X 2
30	00749136	4	NUT TOPLOCK 5/8 NF PLB

IMPORTANT NOTE: Item #3 and Item #9 must be replaced together at the same time, do not change one without the other. If #711052 or #6710510 is ordered a cup and spacer will be shipped together as a kit so order one # or the other, not both.

ITEMS 12, 22, 24, 29, AND 30 ARE NOT FURNISHED WITH GEARBOX ASSEMBLY AND MUST BE SPECIFIED, IF REQUIRED.

GEARBOX ASSEMBLY - RIGHT WING S/N 00101 - 10429 OCT 1977 - MAY 1988

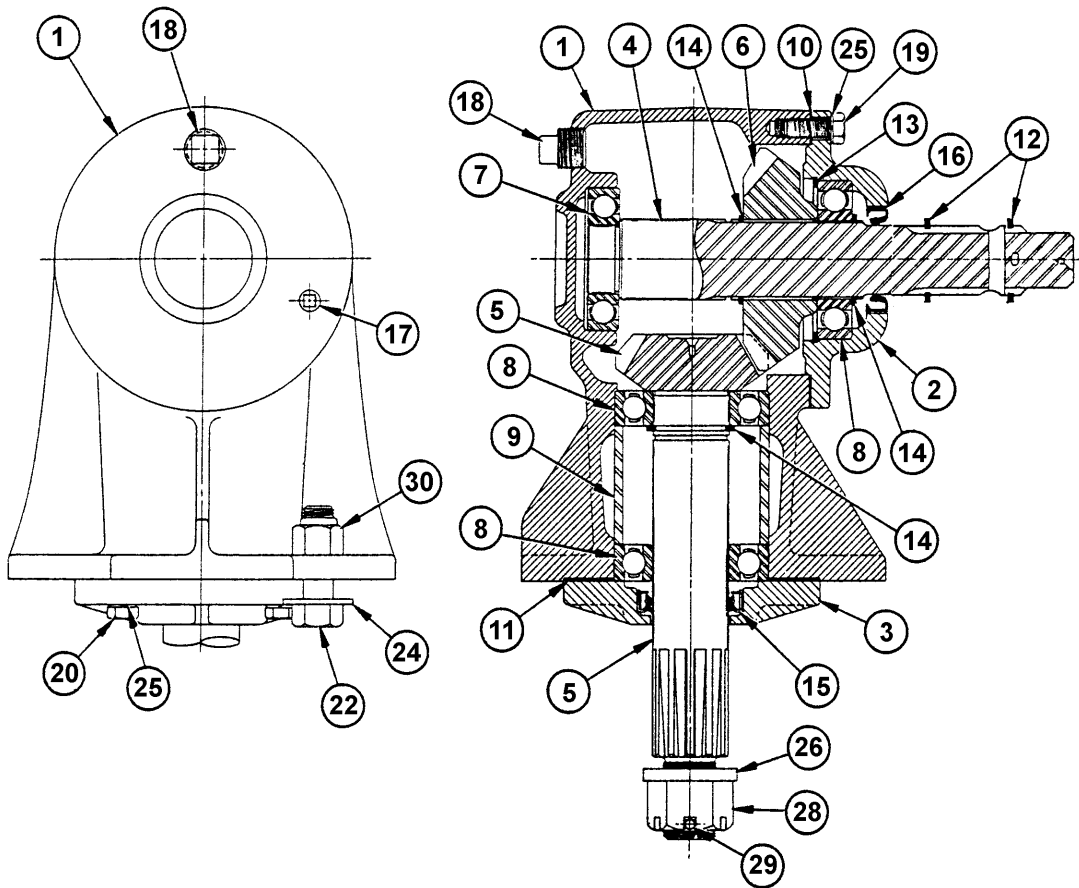

GEARBOX ASSEMBLY - RIGHT WING S/N 00101 - 10429 OCT 1977 - MAY 1988

ITEM	PART NO.	QTY.	DESCRIPTION
	0656220000	-	GEARBOX
1	0656220001	1	HOUSING
2	0656220003	1	CAP
3	00757683	1	CAP, OUTPUT
4	0656220002	1	SHAFT
5	00564000	1	PINION OUTPUT SHAFT
6	00564600	1	INPUT GEAR
7	00564800	1	BEARING,BALL
8	00563700	3	BEARING, BALL
9	00757682	1	SPACER, BEARING
10	00564400	A/R	SHIM
11	00563600	1	GASKET
12	00612703	2	SNAP-RETAINER RING
13	00564500	1	RING,RETAINING
14	00564100	3	RING, RETAINING
15	00563500	1	SEAL, OIL OUTPUT
16	00564200	1	OIL SEAL
17	00565000	1	PLUG, HEX HEAD PIPE 1/8-27NPT
18	00749508	1	PLUG 1/2-14 NPT
19	00011400	6	HHCS 3/8 NC 1 PL5
20	00753642	4	HHCS,3/8NC X 1-1/4,ZP,GRD5
22	7AH5101816	4	C/S 5/8 X 2 NF GR5
23	00751003	1	PIPE PLUG 1/4 NPTM STANDARD
24	W67	4	WASHER
25	00011700	10	LOCKWASHER 5/16 PL STD
26	00768547	1	DECAL - PC2040
28	5E16140	1	NUT CASTLE 1 -14 STD PL
29	00606000	1	PIN-COTTER 3/16 X 2
30	00749136	4	NUT TOPLOCK 5/8 NF PLB

IMPORTANT NOTE: Item #3 and Item #9 must be replaced together at the same time, do not change one without the other. If #711052 or #6710510 is ordered a cup and spacer will be shipped together as a kit so order one # or the other, not both.

ITEMS 12,22,24,29, AND 30 ARE NOT FURNISHED WITH GEARBOX ASSEMBLY AND MUST BE SPECIFIED, IF REQUIRED.

GEARBOX ATTACHMENT - DIVIDER & CENTER GEARBOX S/N 00101 - 10429 OCT 1977 - MAY 1988

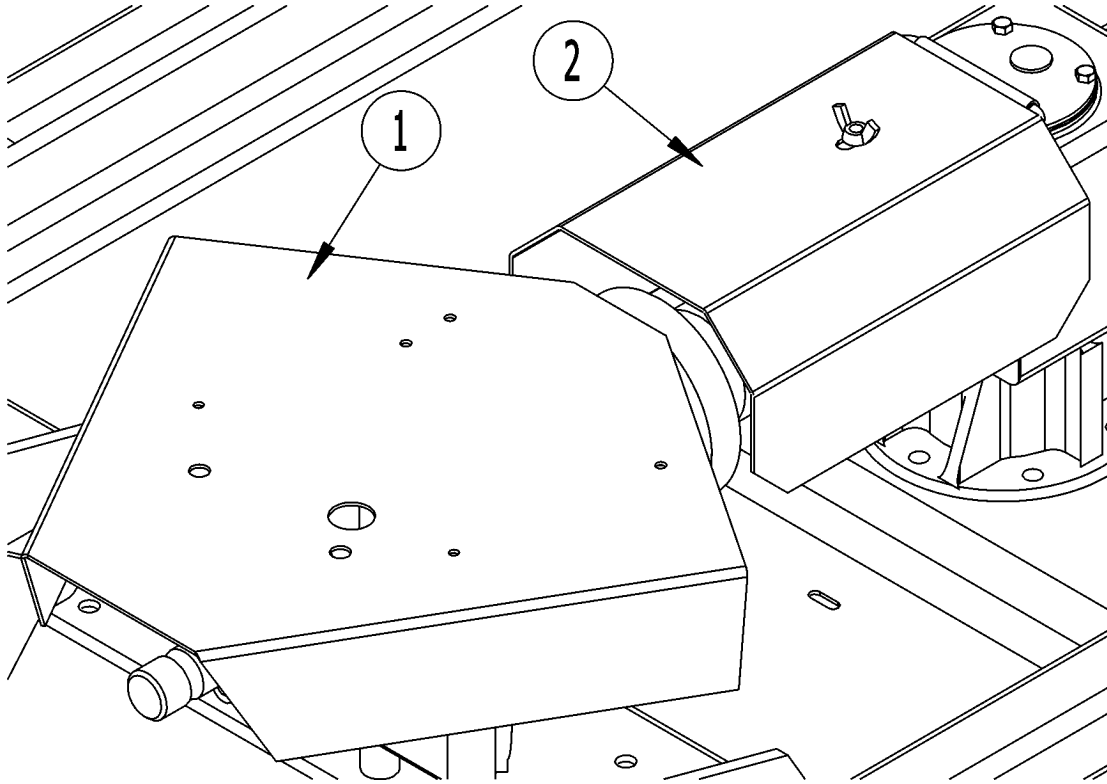

ITEM	PART NO.	QTY.	DESCRIPTION
1	0651470000	1	SHIELD ASSEMBLY
	0656130100	1	SHIELD, PRIMARY GEARBOX
2	0656520000	1	CTR GEAR BOX SHIELD

GEARBOX ATTACHMENT- RIGHT & LEFT WING GEARBOX S/N 00101 - 10429 OCT 1977 - MAY 1988

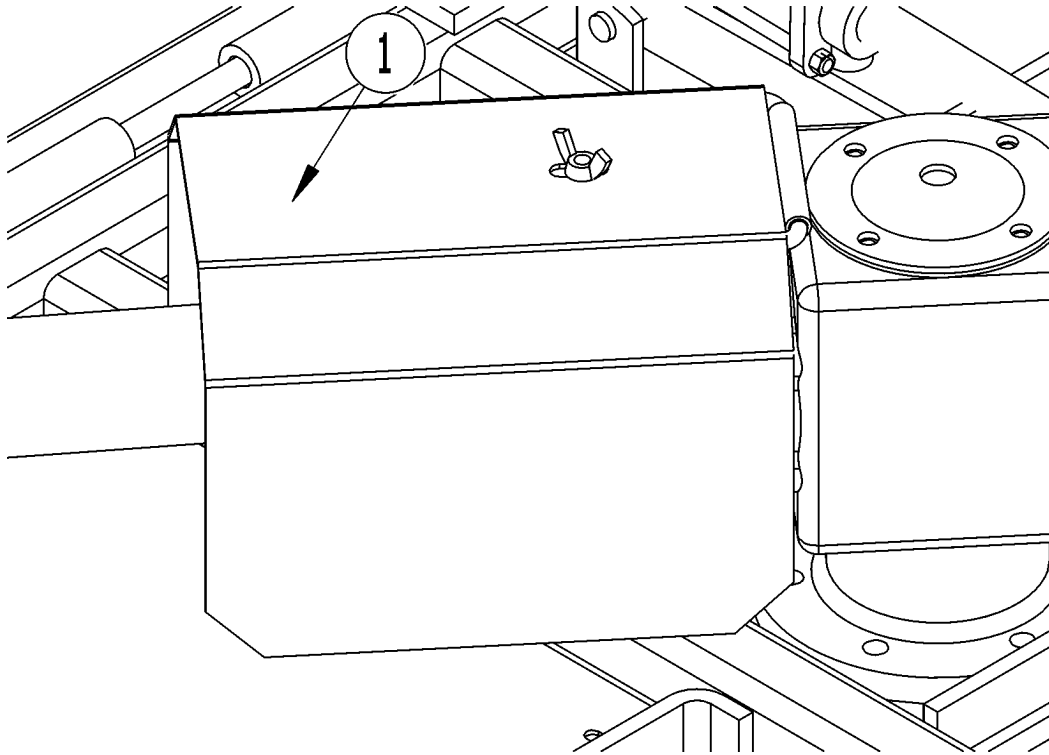

ITEM	PART NO.	QTY.	DESCRIPTION
1	0656451210	1	SHIELD WLD
	0656451110	1	SHIELD WLD

HOSE BRACKET COMPONENTS S/N 00101 - 10429 OCT 1977 - MAY 1988

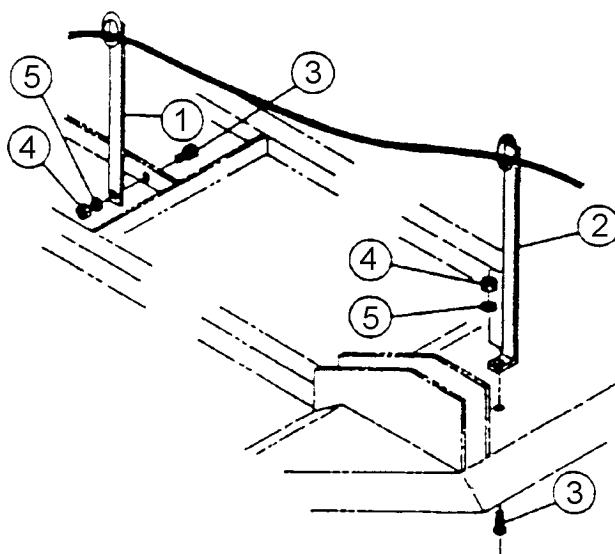

ITEM	PART NO.	QTY.	DESCRIPTION
1	0651140100	1	WLDMT, HYD. HOSE BRKT
2	0651150100	1	HYD. HOSE BRKT.
3	02675800	2	HHCS 5/8-11UNC 1-1/2 PL5
4	00010400	2	NUT 5/8 NC HEX PL
5	00010300	2	LOCKWASHER 5/8 PL STD

HUB ASSEMBLY - CENTER & OUTBOARD S/N 10148 - 10428 JAN 1988 - MAY 1988

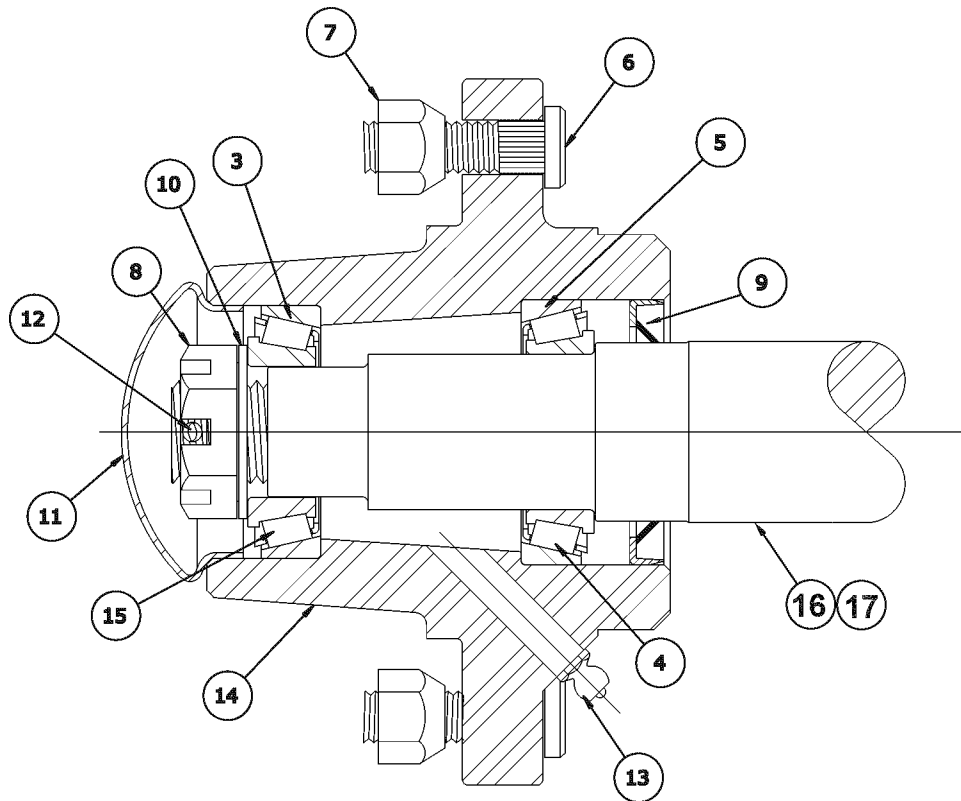

ITEM	PART NO.	QTY.	DESCRIPTION
	00757241		WHEEL HUB, PREASSY
3	00756576	1	BEARING CUP OUTSIDE
4	00750434	1	BEARING CONE INSIDE
5	00756577	4	BEARING CUP INSIDE
6	00752177	5	BOLT, STUD 1/2-20 NF X 1-7/8
7	00750614	5	NUT 1/2-20NF 90DEG.CONE LUG PL
8	00756490	1	NUT SLOTTED THIN 1 NF PLC
9	00750616	1	OIL SEAL
10	00756493	1	WASHER
11	00756492	1	DUST CAP
12	00026200	1	PIN-COTTER 5/32 X 1-1/2
13	00003500	1	ZERK FITTING 1/8 STRAIGHT
14	00756489	1	HUB W/ CUPS & STUBS
15	0371242102	1	BEARING CONE

Note: This hub was used on all center and outboard, standard, level lift axles between these serial numbers. this hub has no washer behind seal on spindle and logo cast into backside of hub.

When using sectional tires install item #7 flat against wheel, opposite picture.

HUB ASSEMBLY - OUTBOARD AXLES S/N 00101 - 10147 OCT 1977 - JAN 1988

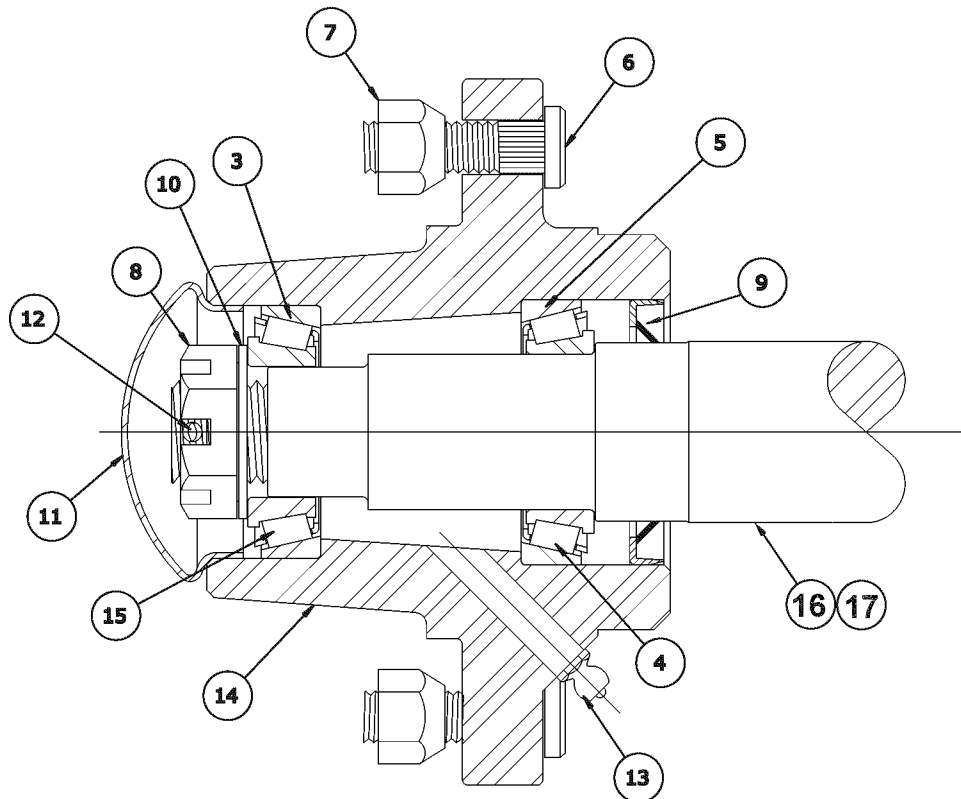

ITEM	PART NO.	QTY.	DESCRIPTION
	271033		HUB GROUP ASSY
3	PT108	1	BEARING CUP
4	00006500	1	BEARING CONE
5	00016900	1	BEARING CUP
6	13198	5	BOLT, HUB
7	00750614	5	NUT 1/2-20NF 90DEG.CONE LUG PL
8	5DR12160	1	NUT 3/4 NF SLOTTED
9	00771458	1	OIL SEAL
10	15B1200	1	WASHER 3/4 P SAE
11	PT112	1	HUB CAP
12	1621/2010	1	CTR
13	00003500	1	ZERK FITTING 1/8 STRAIGHT
14	PT110SA	1	WHEEL HUB
15	PT109	1	BEARING CONE

Note: When using sectional tires install item #7 flat against wheel, opposite picture.

HUB ASSEMBLY - STANDARD CENTER AXLE S/N 00101 - 10147 OCT 1977 - JAN 1988

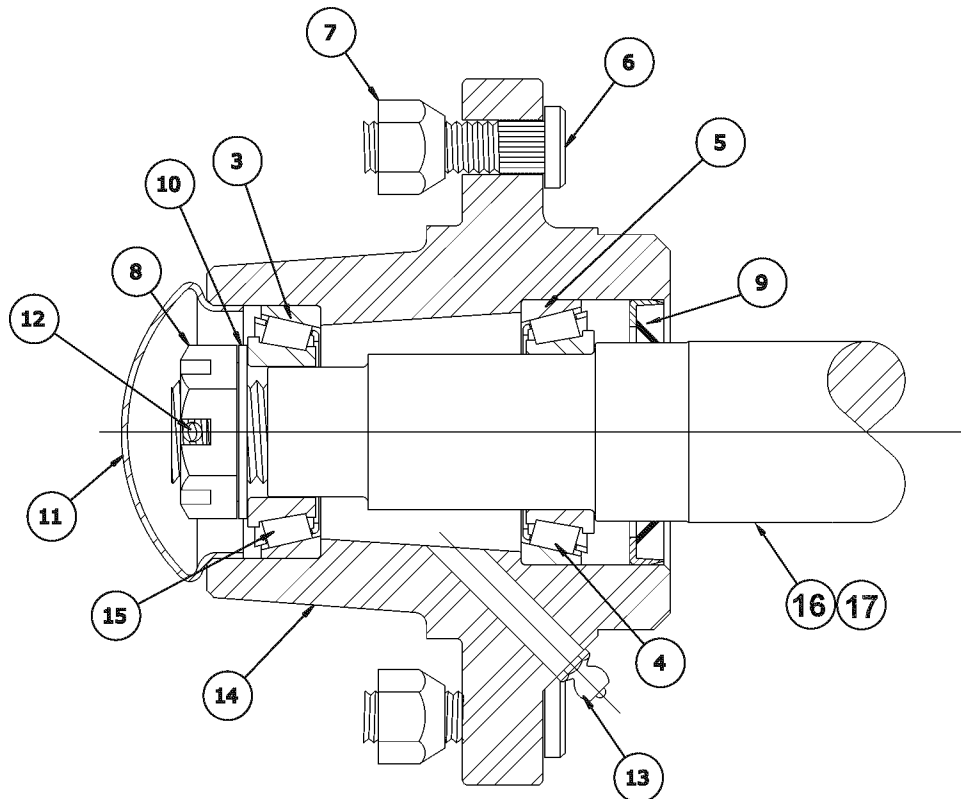

ITEM	PART NO.	QTY.	DESCRIPTION
	371247		HUB, ASY
3	00016900	1	BEARING CUP
4	371247E	1	BEARING CONE 342A
5	371247D	1	BEARING CUP 332
6	13198	5	BOLT, HUB
7	00750614	5	NUT 1/2-20NF 90DEG.CONE LUG PL
8	371247J	1	NUT, 7/8-14 UNF STD SLOTTED
9	371247F	1	SEAL
10	371247H	1	WASHER
11	371247H	1	WASHER
12	1621/2012	1	PINS-CTR 5/32 X 1 1/2
13	00003500	1	ZERK FITTING 1/8 STRAIGHT
14	371247SA	1	HUB
15	371247C	1	BEARING CONE

Note: Spindel will have washer welded to it behind seal. When using sectional tires install item #7 flat against wheel, opposite picture.

HYDRAULIC CONTROL VALVE MOUNTING KIT S/N 00101 - 10429 OCT 1977 - MAY 1988

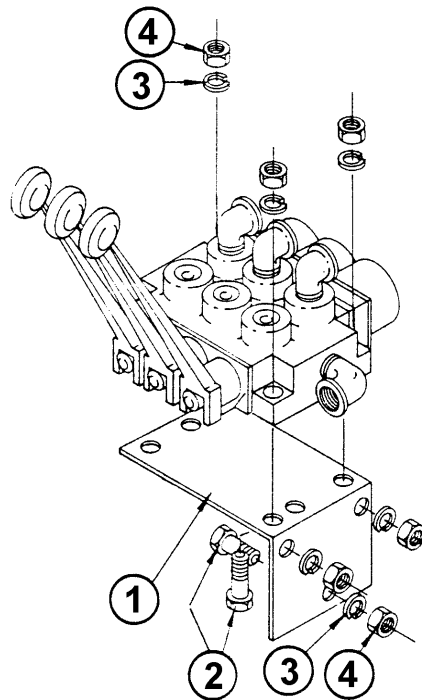

ITEM	PART NO.	QTY.	DESCRIPTION
1	651401	1	MT BKT WLD
2	00016200	6	HHCS 5/16NC 2 PL5
3	13500	6	L WSHR 5/16
4	5B5180	6	NUT 5/16 NC HEX

HYDRAULIC HOSE ADAPTERS S/N 00101 - 10429 OCT 1977 - MAY 1988

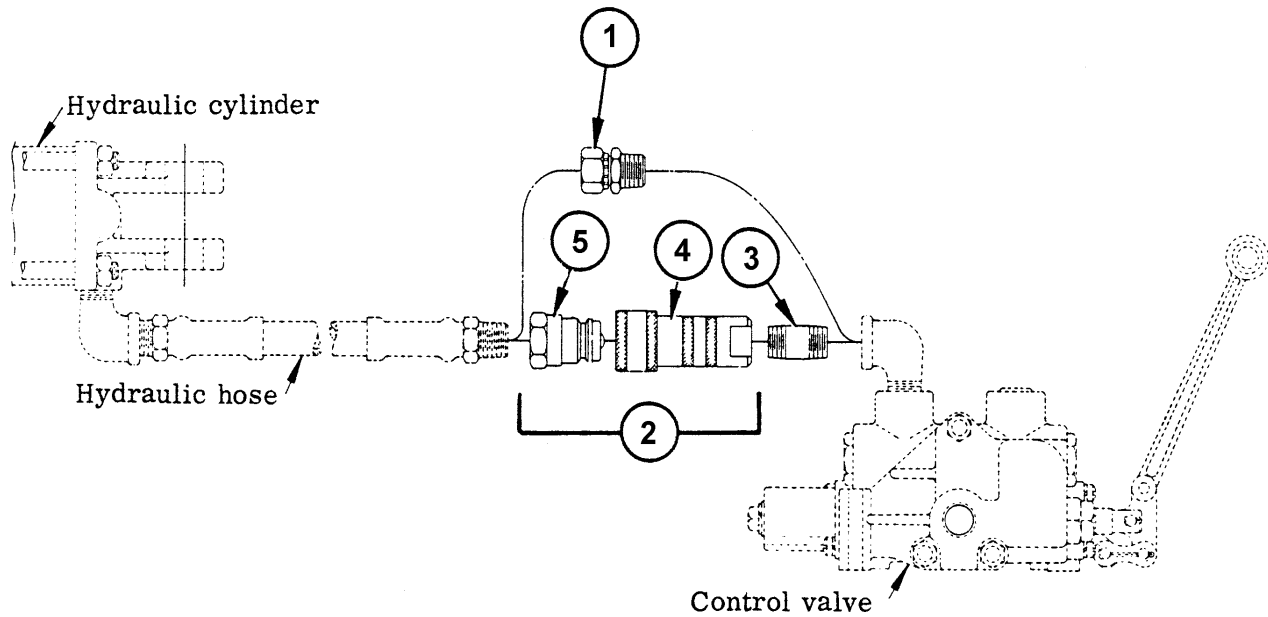

ITEM	PART NO.	QTY.	DESCRIPTION
2	00275400	3	Q.D, COUPLER #8
4	651311	3	QD COUPLER HALF FEMALE
5	651312	3	COUPLER HALF, MALE

Note: Choice of couplers is up to the customer.

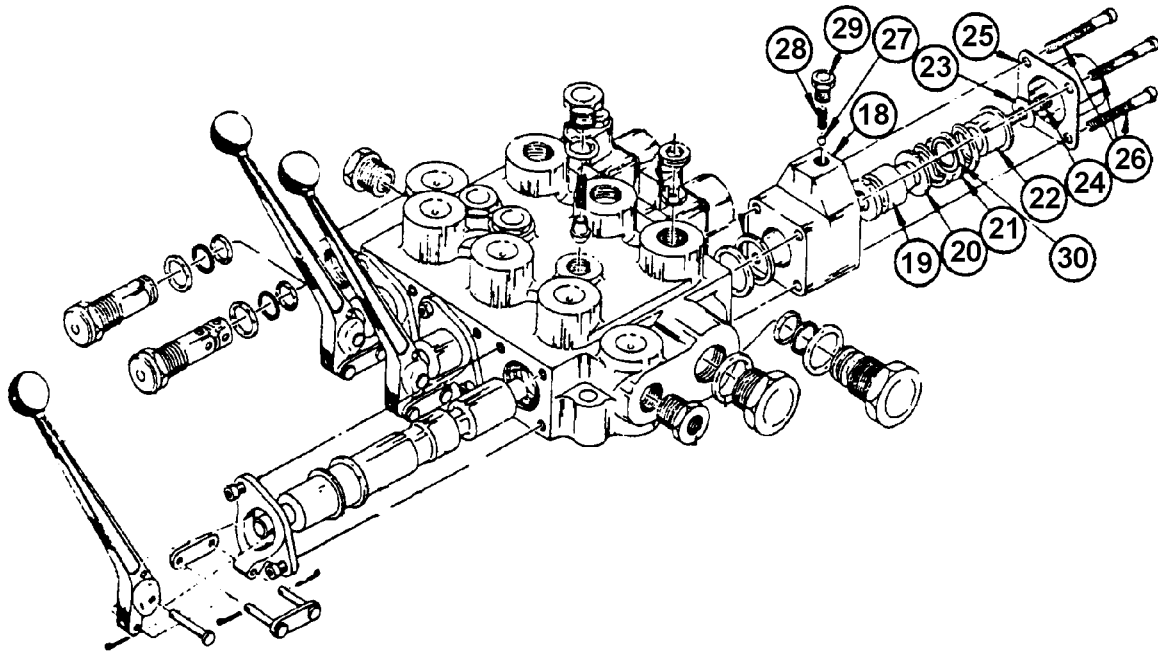

ITEM	PART NO.	QTY.	DESCRIPTION
18	6514016	1	HOUSING DETENT
19	6514017	1	SLEEVE
20	6514018	1	WASHER
21	6514019	1	SPRING CENTERING (25#)
22	6514020	1	COLLAR STEP
23	6514021	1	WASHER
24	7E42012	1	C/S1/4 X 1 1/2 SK HD
25	6514022	1	CAP,END
26	7D42014	4	BOLT
27	6514023	1	BALL 1/4 STEEL
28	6514024	1	SPRING
29	6514025	1	PLUG
30	65140A54	1	WASHER

Standard quantities for one Detent Assembly 3 required per hydraulic valve.

HYDRAULIC VALVE ASSEMBLY - OPEN/CLOSED CENTER VALVE S/N 00101 - 10429 OCT 1977 - MAY 1988

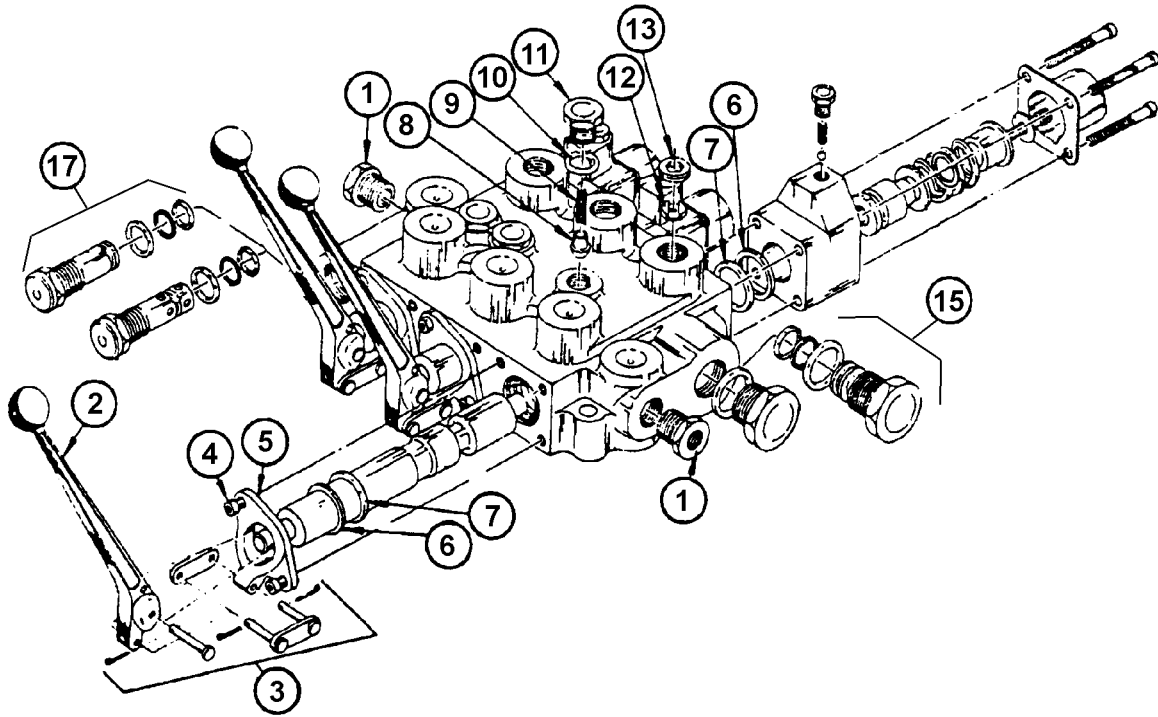

ITEM	PART NO.	QTY.	DESCRIPTION
1	19E13/41/2	2	PIPE BUSHING
2	65140A47	3	HANDLE
3	65140A48	3	KIT-PIN
4	7E4204	6	SHCS 1/4 NC 1/2
5	65140A46	3	BRKT
6	6514012	6	PLATE RETAINER
7	6514013	6	SEAL, O-RING
8	6514026	3	POPPET
9	6514027	3	SPRING,LIFT CHECK
10	6514028	3	SEAL, O-RING
11	6514029	3	PLUG
12	6514030	3	PLATE, 1/16 ORIFICE
13	6514031	3	RETAINER
14	65140A50	1	NON -ADJUSTABLE RELIEF ASSEMBLY (OPEN CENTER ONLY)
15	6514042	1	CLOSED CENTER ASSEMBLY (CLOSED CENTER ONLY)
16	6514039	1	CONVERSION PLUG ASSEMBLY
17	6514037	1	NO-RELIEF ASSEMBLY (CLOSED CENTER ONLY)

JACK ASSEMBLY - TOP WING S/N 00101 - 10429 OCT 1977 - MAY 1988

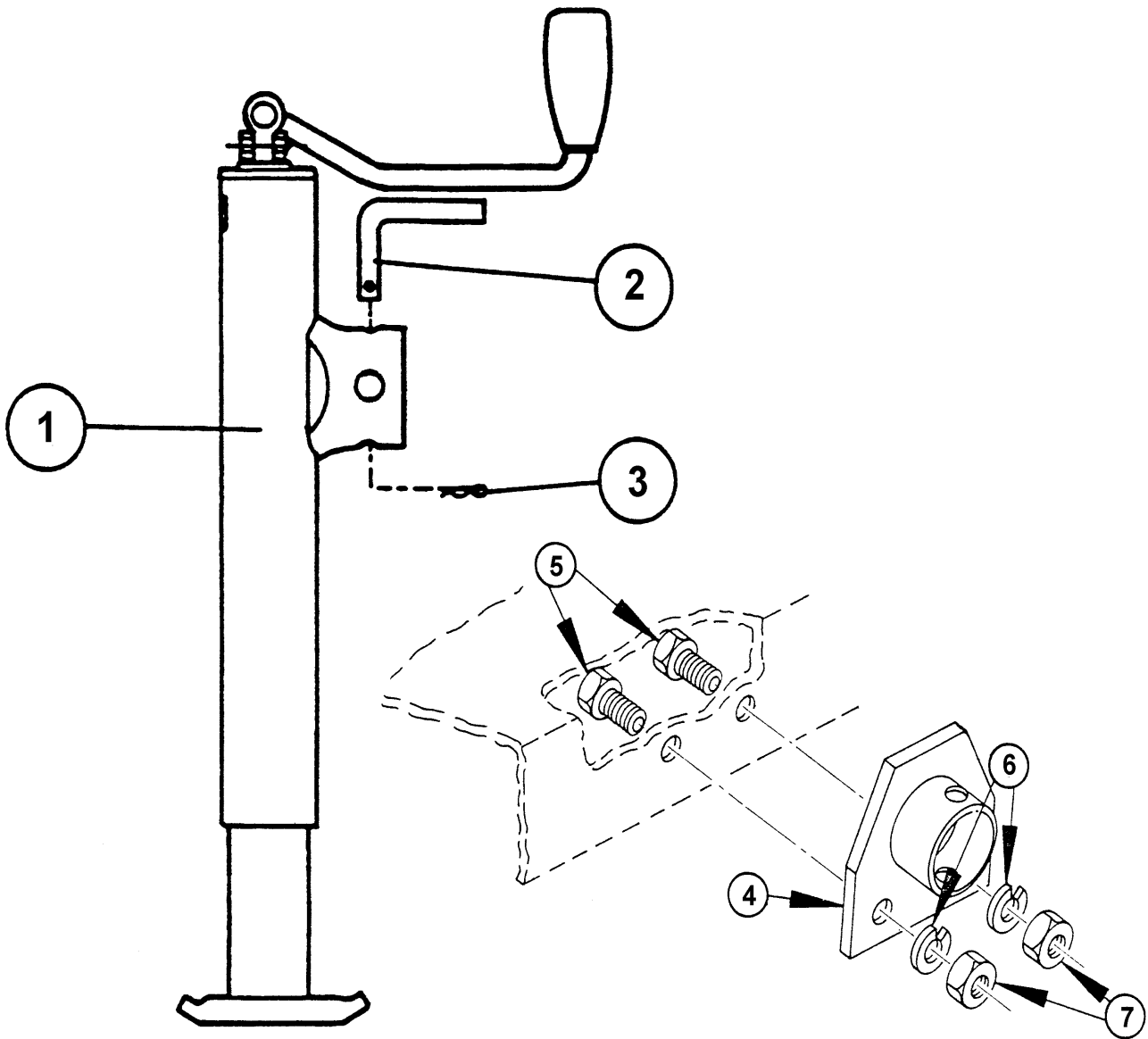

ITEM	PART NO.	QTY.	DESCRIPTION
1	0811140000	1	PARKING JACK
2	00749892	1	PIN-JACK RETAINING
3	00751685	1	PIN-CLIP HAIR
4	651081W	1	BKTS PARKING JACK
5	7A101116	2	BLT 5/8 X 2 ZP
6	131000	2	LOCK WASHER
7	5B10110	2	NUT 5/8 HEX, ZP

LEFT SCREW S/N 00101 - 10429 OCT 1977 - MAY 1988

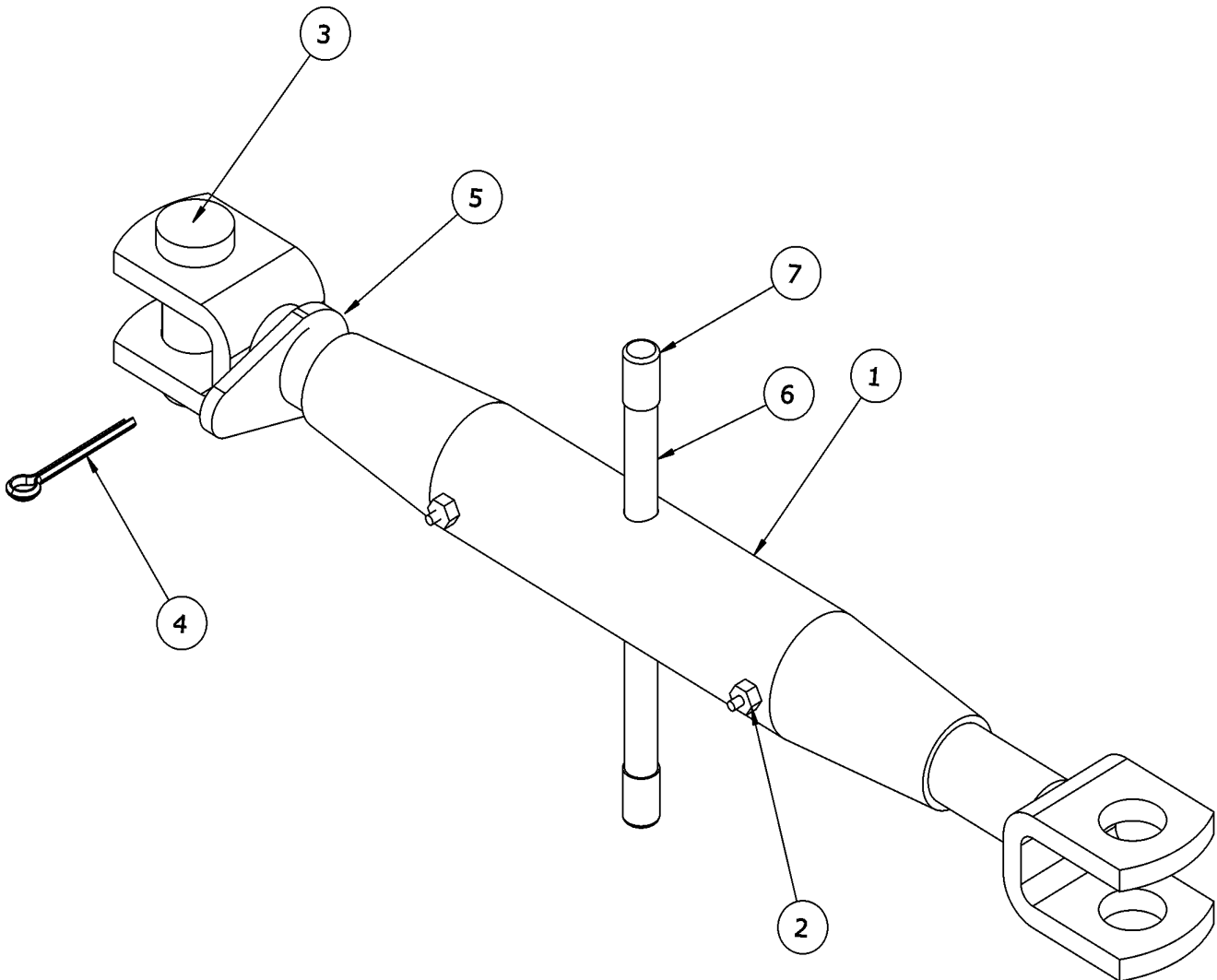

ITEM	PART NO.	QTY.	DESCRIPTION
1	0656510000	1	MANUAL-LIFT SCREW
2	651062F	2	FITTING,GREASE (DRIVE TYPE)
3	00609200	2	HEXB 1 NC 4 GR5
4	02030300	2	NUT TOPLOCK 1 NC PLB
5	00760135	1	HANDLE,MANUAL LIFT SCREW
6	00756579	1	TOP LINK THREAD LOCK
?7	0656510001	1	MANUAL-LIFT SCREW

LEVEL LIFT KIT FIELD INSTALLATION S/N 00101 - 10429 OCT 1977 - MAY 1988

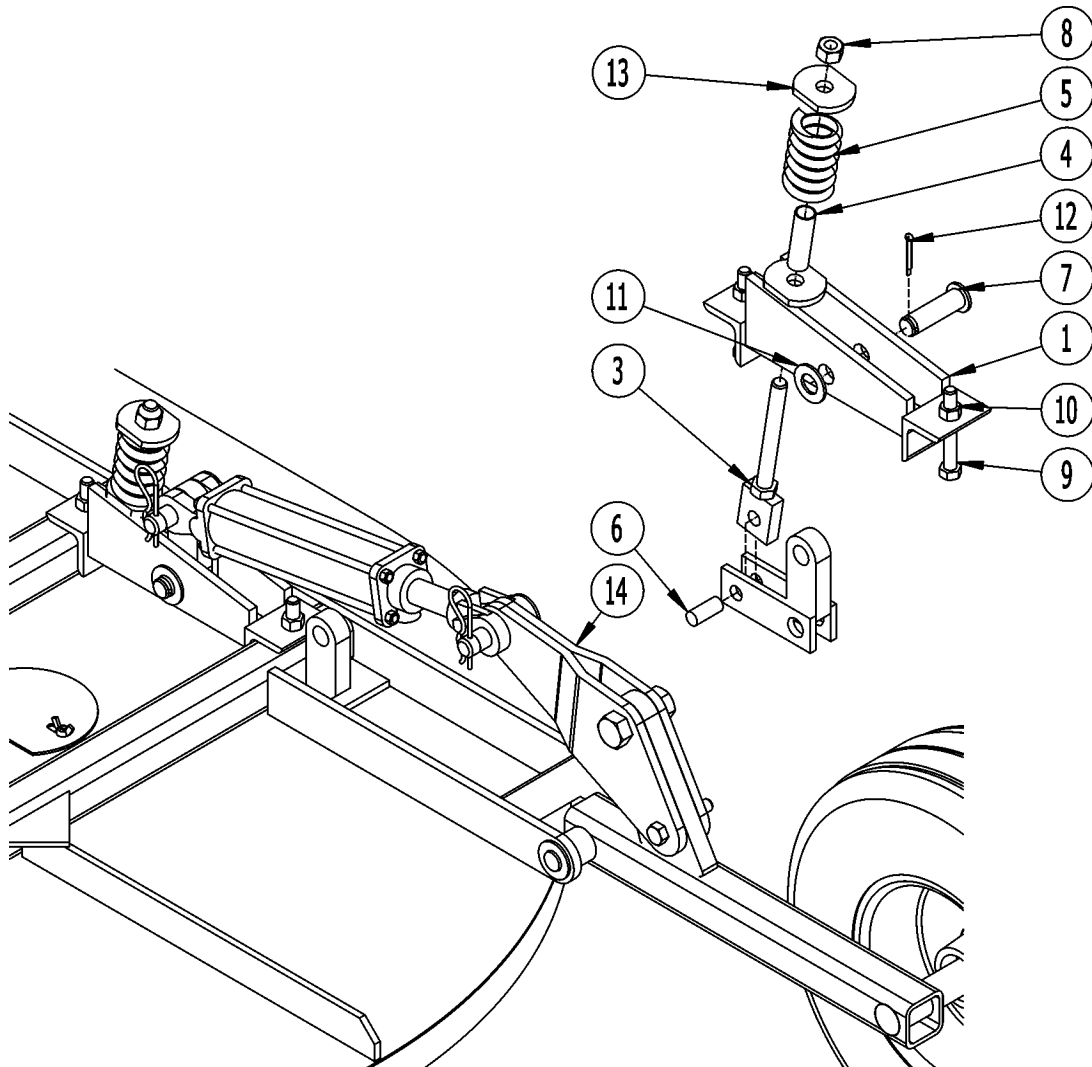

ITEM	PART NO.	QTY.	DESCRIPTION
1	0652140120	1	WLDMT, BASE
2	0652140130	1	WLDMT, PIVOT ARM
3	0652140140	1	WLDMT, SPRING ROD
4	0652140150	1	SPRING GUIDE
5	371063A	1	SPRING
6	0652140160	1	PIN
7	691154	1	PIN
8	5GR12100	1	LOCKNUT TLM 3/4 NC PL
9	7AH5101132	2	C/S 5/8 X 4 NC GR.5
10	02956948	2	LOCKNUT 5/8 NC PLC
11	15B1600	1	WASHER 1 SAE P
12	163016	1	PIN, COTTER 3/16 X 2
13	65107A3C	1	WASHER
14	0652150100 0652150000	1	AXLE LUG ASSEMBLY LEVEL LIFT KIT FS15

Note: Factory level lift did not use bracket #14 on axle arms. Axle arms had longer lugs on them.

To order complete field installation level lift kit, including hydraulic cylinders and hoses, order bundle #0652150000. (Most current type cylinder used will be used shipped)

LEVEL LIFT ROD ASSEMBLY S/N 10148 - 10428 JAN 1988 - MAY 1988

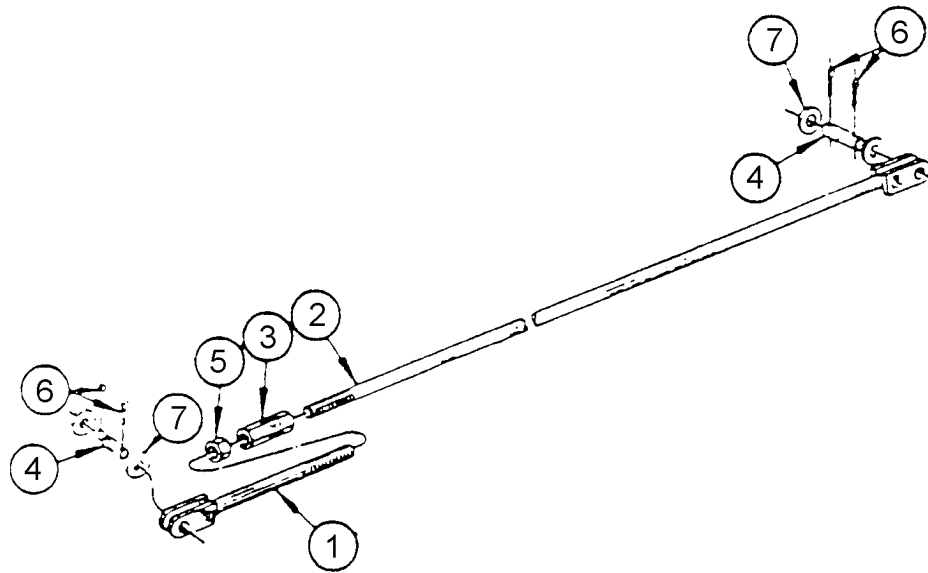

ITEM	PART NO.	QTY.	DESCRIPTION
1	584042	2	WLDMT-ROD CONTROL
2	651101	2	ROD
3	00770485A	2	NUT,EXTENDED ADJUSTMENT
4	651102	4	PIN-DRILLED
5	5C1490	2	HEXNUT 7/8 JAM ZP
6	00606000	8	PIN-COTTER 3/16 X 2
7	15B1200	8	WASHER 3/4 P SAE

MAINFRAME ASSEMBLY S/N 00101 - 01900 OCT 1977 - FEB 1985

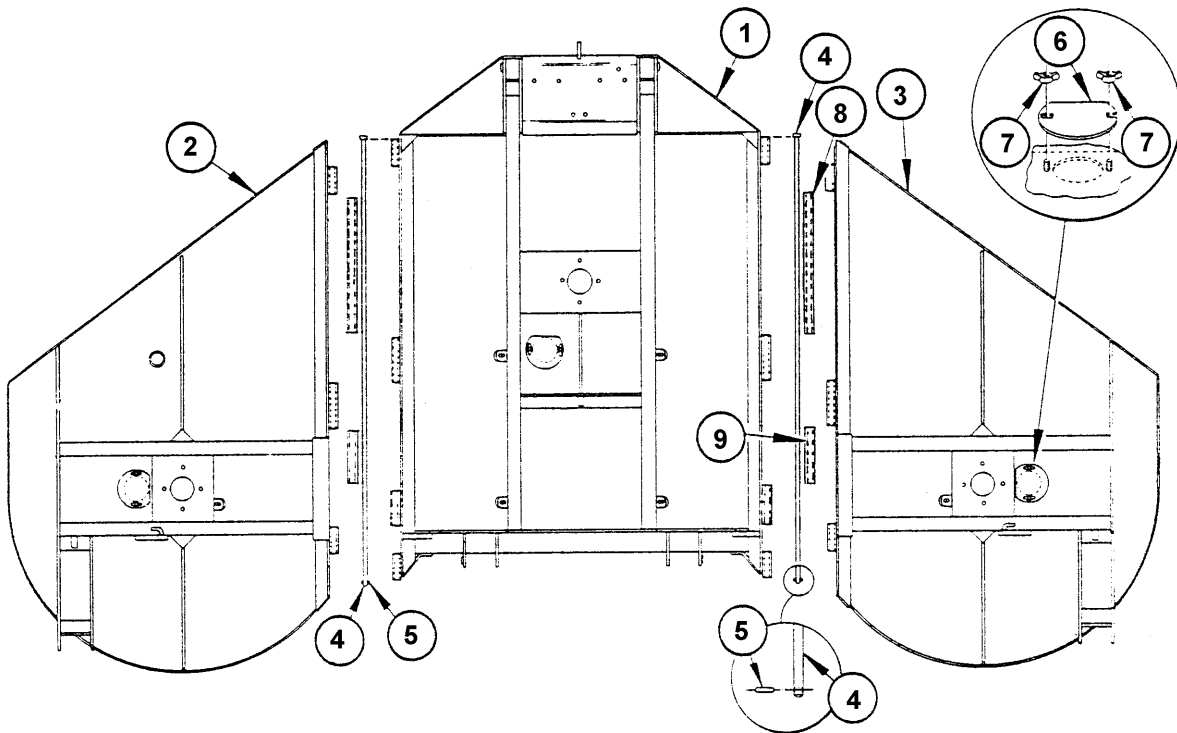

ITEM	PART NO.	QTY.	DESCRIPTION
1	0656011000	1	WLDMT, FS15 CTR SECT M.FF
2	0656020200	1	L/H O/B FRAME WLD
3	0656020100	1	R/H O/B FRAME WLD
4	65109	2	PIN HINGE
5	20A4012E	2	PIN
6	5710121	3	COVER PLATE
7	5F5180	6	NUT 5/16 NC WING
8	0656270000	2	T,SPACER, LONG
9	0656261000	2	SPACER, SHORT HINGE
	0656260000	2	SPACER, SHORT

Note: Later models replaced lock pin w/bolts and nut. Part number 7A51812 bolt, 5GR5180 locknut.

PART NUMBER 0656261000 REPLACES PART NUMBER 0656260000 FOR SERIAL # 00631 AND ON. PART NUMBER 0656261000, 21-5/8" LONG. PART #0656260000, 171/4" LONG.

MAINFRAME ASSEMBLY S/N 01901 - 10429 FEB 1985 - MAY 1988

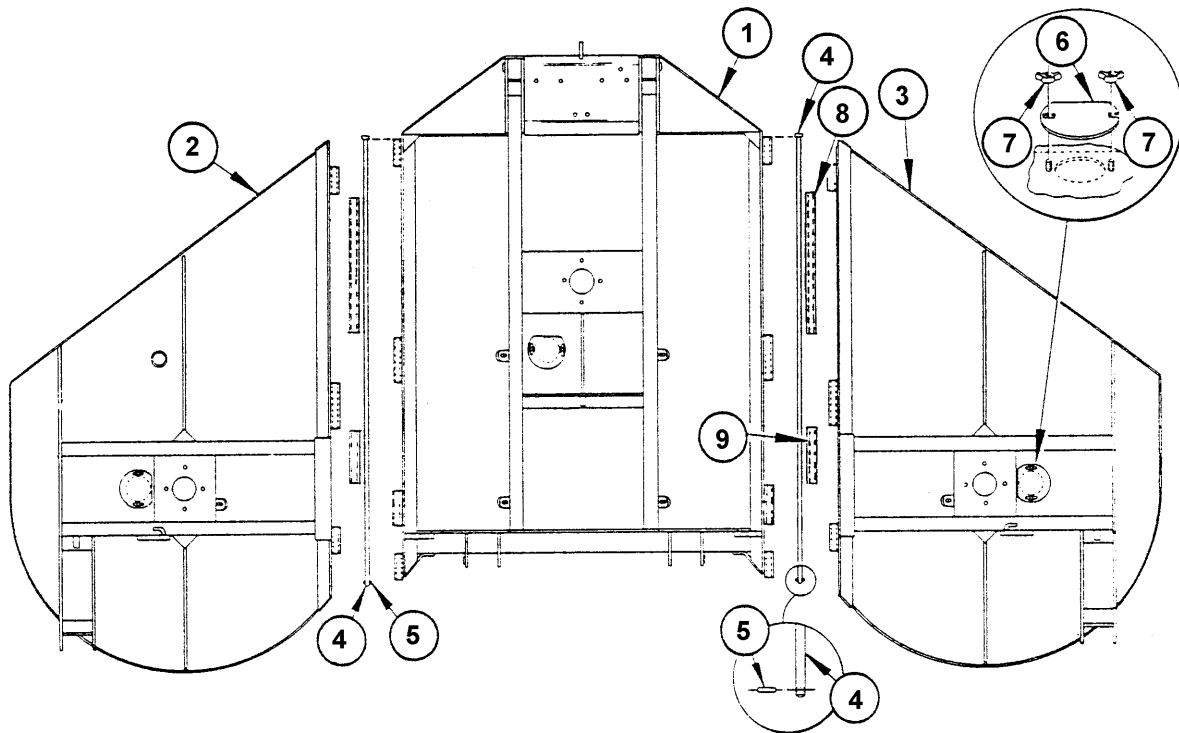

ITEM	PART NO.	QTY.	DESCRIPTION
1	0656011000	1	WLDMT, FS15 CTR SECT M.FF
2	0656020200	1	L/H O/B FRAME WLD
3	0656020100	1	R/H O/B FRAME WLD
4	65109	2	PIN HINGE
5	20A4012E	2	PIN
6	5710121	3	COVER PLATE
7	5F5180	6	NUT 5/16 NC WING
8	0656270000	2	T,SPACER, LONG
9	0656261000	2	SPACER, SHORT HINGE
	0656260000	2	SPACER

Note: Later models replaced lock pin w/bolts and nut. Part number 7A51812 bolt, 5GR5180 locknut.

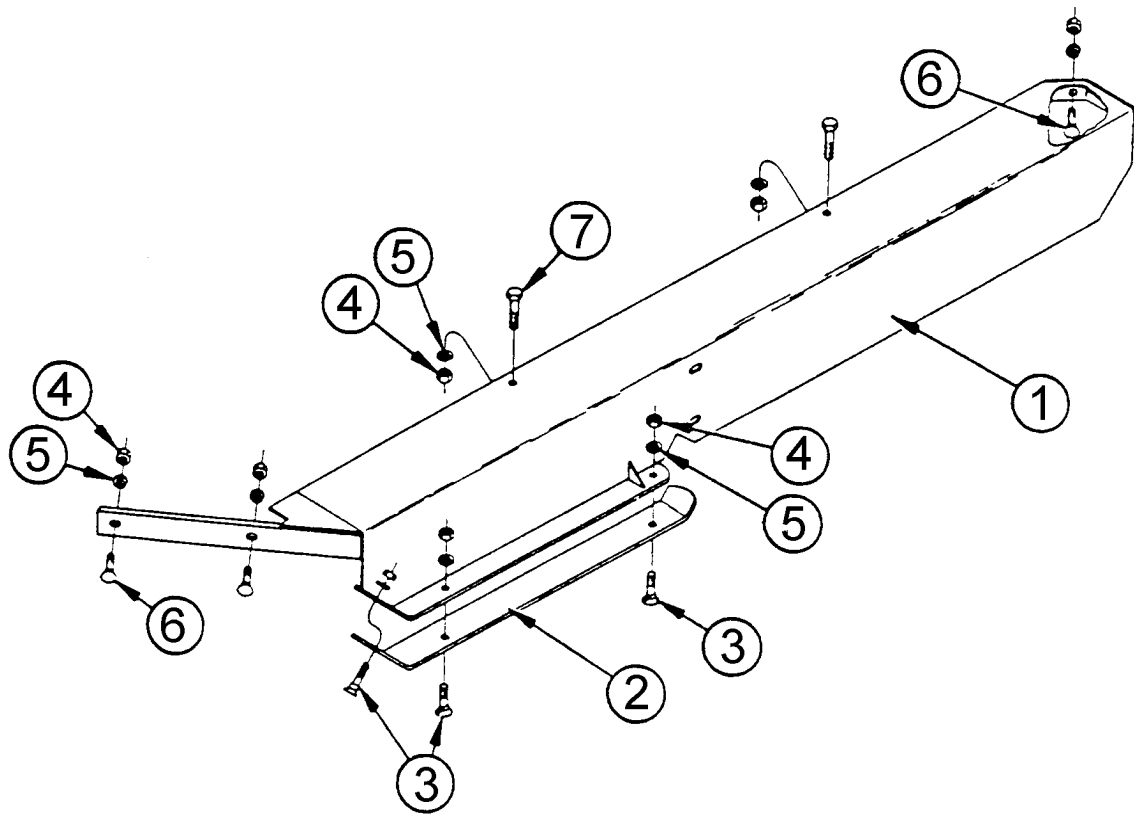

ITEM	PART NO.	QTY.	DESCRIPTION
1	652071	1	SIDESKIRT WLDMT, LEFT SIDE
2	65203L	1	SHOES SLIDE
3	2A381312	3	BOLT,PLOW 1/2 NC X 1-1/2 GR.5
4	00001200	8	NUT,HEX 1/2 NC PL
5	00001300	8	LOCKWASHER 1/2 PL STD
6	281316	3	CARB 1/2NC X 2
7	00748823	2	HHCS 1/2-13UNC 1-1/2 PL5

SKID SHOE & SIDE SKIRT S/N 00101 - 10429 OCT 1977 - MAY 1988

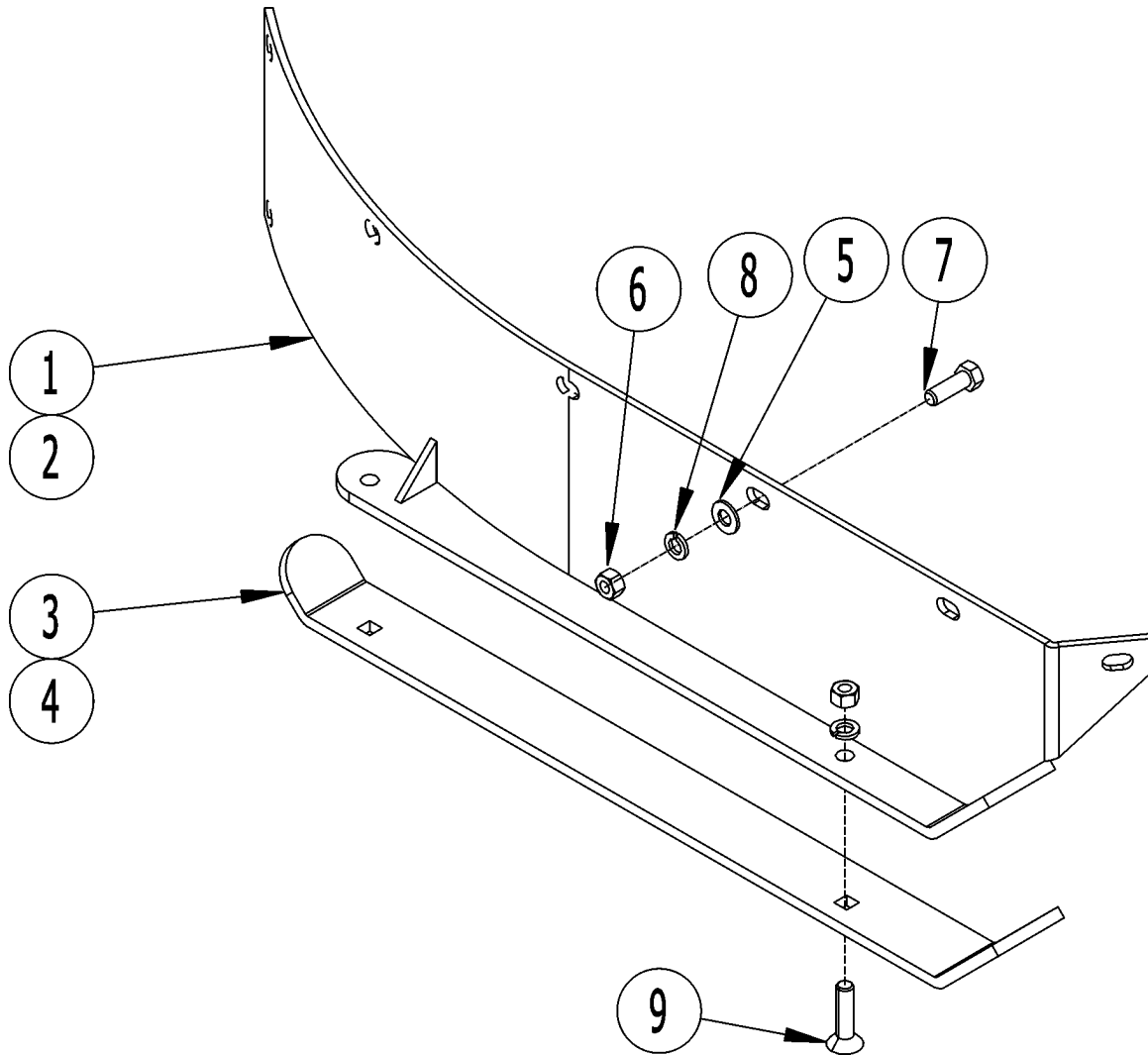

ITEM	PART NO.	QTY.	DESCRIPTION
1	65202RW	1	SKIRT SIDE
2	65202LW	1	SKIRT SIDE
3	65203R	1	SHOES SLIDE
4	65203L	1	SHOES SLIDE
5	15B800	12	WASHER 1/2 SAE ZP
6	00001200	18	NUT,HEX 1/2 NC PL
7	7A81312	12	C/S1/2 X 1 1/2 NC
8	13800	18	LOCK WASHER
9	2A381312	6	BOLT,PLOW 1/2 NC X 1-1/2 GR.5
10	D303	2	DECAL,RHINO
11	D337	2	DECAL-FLX-S-15

Note: This side skirt is 1/4" thick. Replace old 3/16" Thick side skirt with out modification.

SKID SHOE ASSEMBLY S/N 00101 - 00466 OCT 1977 - FEB 1979

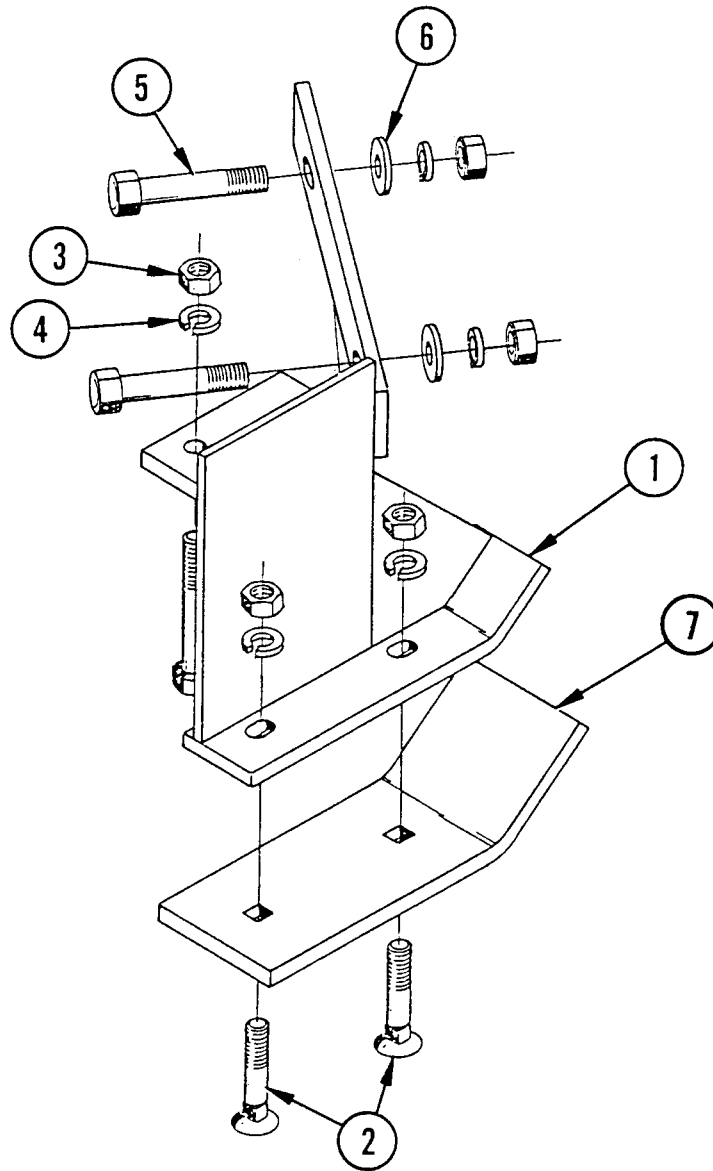

ITEM	PART NO.	QTY.	DESCRIPTION
1	0656490010	1	ASY,RIGHT SKID SHOE
	0656490020	1	ASY,LEFT SKID SHOE
2	2A381312	2	BOLT,PLOW 1/2 NC X 1-1/2 GR.5
3	00001200	5	NUT,HEX 1/2 NC PL
4	13800	5	LOCK WASHER
5	00013300	3	HEXB 1/2 NC 2 PL5
6	15B800	2	WASHER 1/2 SAE ZP
7	0656490107	1	WEAR PLATE

Note: Later Models have item 1 welded to center section of the mainframe at assembly. These can be used to replace skid shoe mount broken off on units

SKID SHOE ASSEMBLY S/N 00101 - 10429 OCT 1977 - MAY 1988

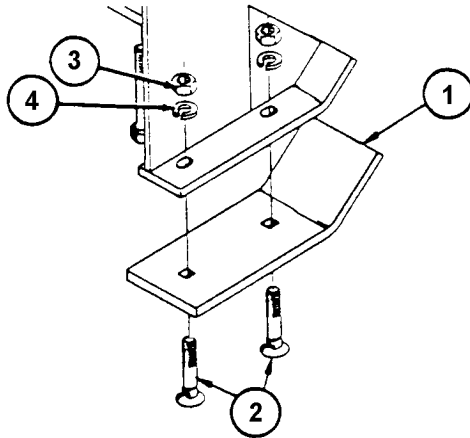

ITEM	PART NO.	QTY.	DESCRIPTION
1	0656490107	1	WEAR PLATE
2	2A381312	2	BOLT,PLOW 1/2 NC X 1-1/2 GR.5
3	00001200	2	NUT,HEX 1/2 NC PL
4	13800	2	LOCK WASHER

SPRING ASSEMBLY - CENTER AXLE S/N 00101 - 10429 OCT 1977 - MAY 1988

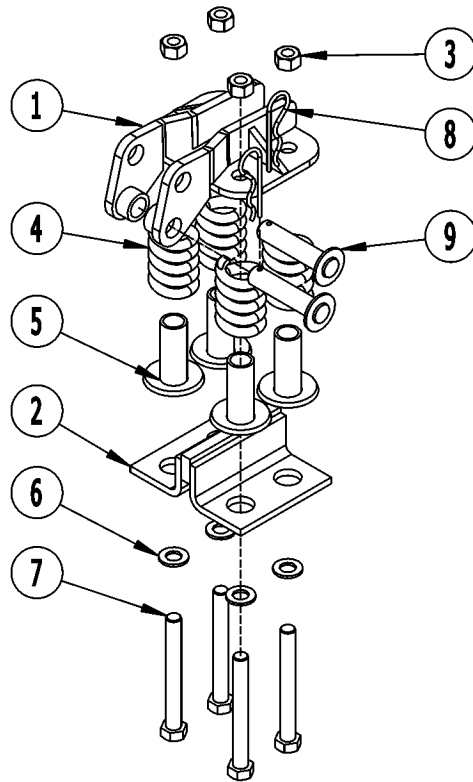

ITEM	PART NO.	QTY.	DESCRIPTION
1	0656460110	1	UPPER SPRING WLD
2	0656460120	1	LOWER SPRING WLD
3	5JRC12100	4	NUT TOPLOCK 3/4
4	371063A	4	SPRING
5	65107A4	4	GUIDE SPRING
6	00002701	4	FLATWASHER, 3/4, TYPE AW, ZP
7	02023800	4	HEXB 3/4 NC 6-1/2PL
8	37107B13	2	CLIP-X HAIR PIN
9	0656460240	2	WLDMT-PIN

Note: Center Spring Assembly was optional eqpt.

SPRING ASSEMBLY - WING S/N 00101 - 10429 OCT 1977 - MAY 1988

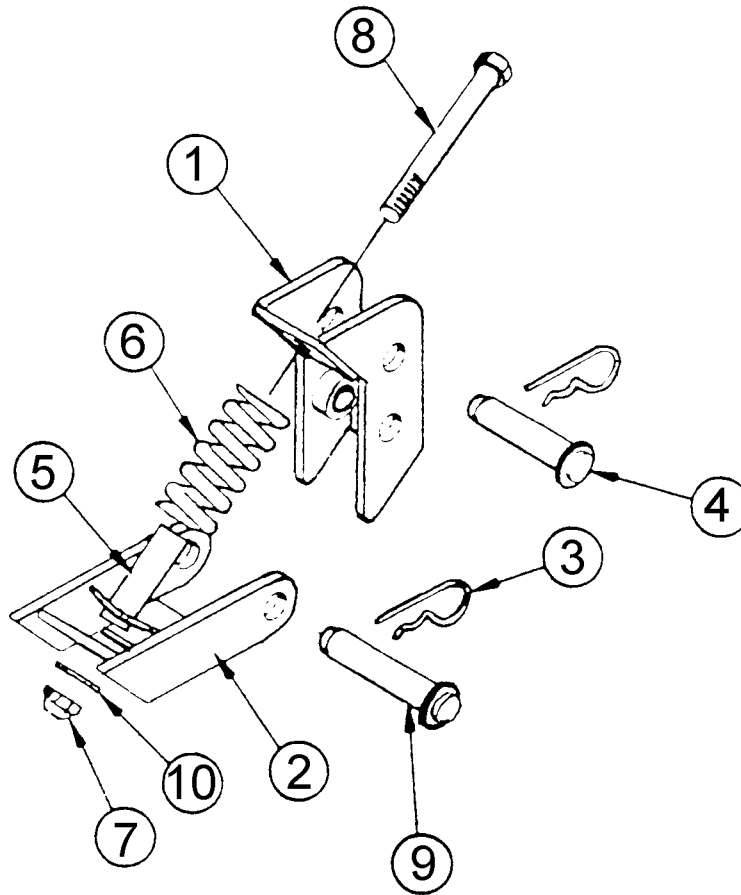

ITEM	PART NO.	QTY.	DESCRIPTION
	0656460200		OUTBOARD SPRING ASSY
1	0656460220	1	ROCKER ARM WLD
2	0656460210	1	SPRING BASE WLD
3	37107B13	2	CLIP-X HAIR PIN
4	0656460230	1	PIN-WLD
5	65107A4	1	GUIDE SPRING
6	371063A	1	SPRING
7	00037200	1	NUT TOPLOCK 3/4 NC PLC
8	02023800	1	HEXB 3/4 NC 6-1/2PL
9	0656460240	1	WLDMT-PIN
10	00002701	1	FLATWASHER,3/4,TYPE AW,ZP

Note: These sere not used on units with hyd level lift. See level lift section for spring assy's used

TIRE/WHEEL ASSEMBLY S/N 00101 - 10429 OCT 1977 - MAY 1988

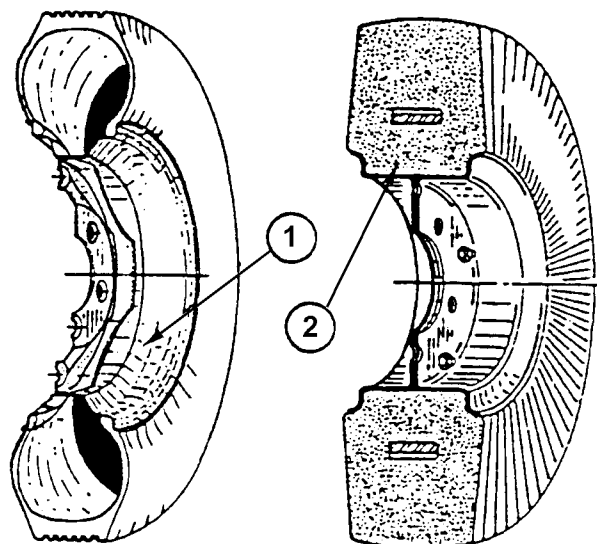

ITEM	PART NO.	QTY.	DESCRIPTION
1	00008700	1	WHEEL, 15 X 5.00 DC (RIM ONLY)
1	00019200	1	WHEEL 14 X 5.00 DC (RIM ONLY)
2	00025200 00749700	1	LAMINATED PUNCTURE-PROOF TIRE & WHEEL ASSEMBLY (21" OD) 6.00 X 9 14" AIRPLANE TIRE AND WHEEL

ALSO AVAILABLE

Used 14" Airplane Tire and Wheel - P/N 00749700 (not shown)

TONGUE ASSEMBLY S/N 00101 - 10429 OCT 1977 - MAY 1988

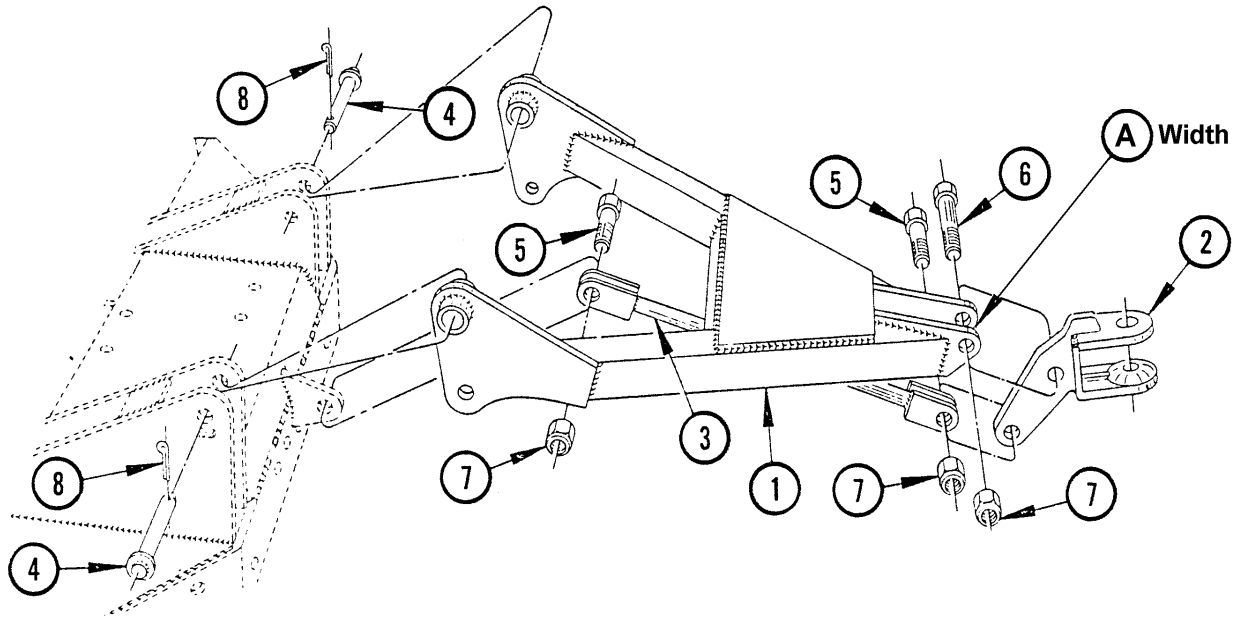

ITEM	PART NO.	QTY.	DESCRIPTION
1	B65105	1	TONGUE
	651051	1	WLDMT, TONGUE
2	0656050200	1	WLDMT, TONGUE HITCH, FS15 PART
	651052	1	CLEVIS, TONGUE
3	0656050300	1	TNG-HITCH CONT ROD
	651053	1	ROD HITCH CONTROL
4	651054	2	PIN-TONGUE PIVOT
5	7AH5121620	2	C/S 3/4 X 2 1/2 NF 5
6	00752161	1	HHCS 3/4 NF 3 PL5
	7AH5121636	6	C/S 3/4 X 4 1/2 NF 5
7	00748539	3	NUT TOPLOCK 3/4 NF PLB
8	00606000	2	PIN-COTTER 3/16 X 2

Note: Item #6 has ears cast on to it. Check before ordering. Item #5 bronze bushing

TORQUE LIMITER ASSEMBLY S/N 00101 - 10001 OCT 1977 - AUG 1987

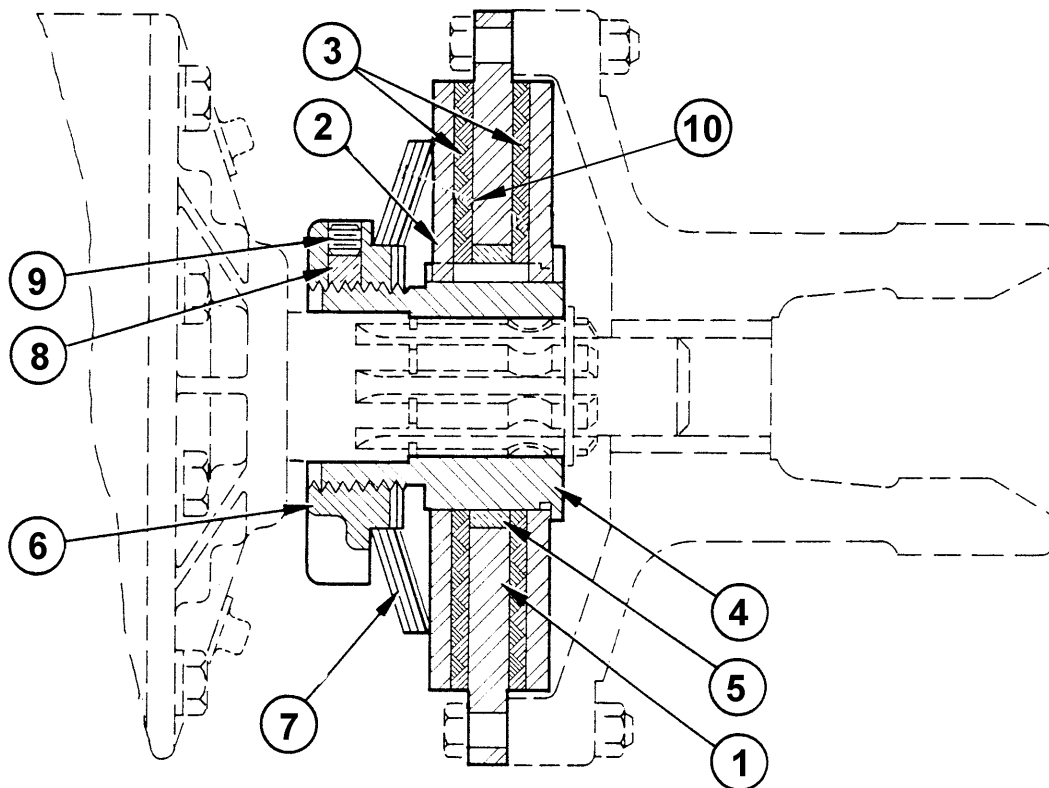

ITEM	PART NO.	QTY.	DESCRIPTION
	70105		TORQUE LIMITER ASSY
1	701052	1	DRIVE PLATE
2	00748832	1	PLATE,PRESSURE
3	00748833	2	DISC,CLUTCH
4	701054R	1	HUB, TORQUE LIMITER
5	00748825	1	BUSHING
6	701055R	1	NUT ADJ TOPLOCK
7	00748831	4	SPRING, BELLEVILLE
8	701053R	1	PLUG BRONZE
9	9C16163	1	SHSS CUP POINT 3/8NC X 3/8 PL
10	00748834	1	BACK PLATE

Note: Item #7 is hex shaped nut. Check before ordering.

Notice: Most Parts are interchangeable with the Warner-Motive Torque Limiter (70105). To prevent damage to the assembly, do not use or mix 0731070006 spring together with 701056 spring on the sam assembly. Also, replacement of the disc and spring with Warner parts will lower the capacity of the

TORQUE LIMITER ASSEMBLY S/N 10001 - 10429 AUG 1987 - MAY 1988

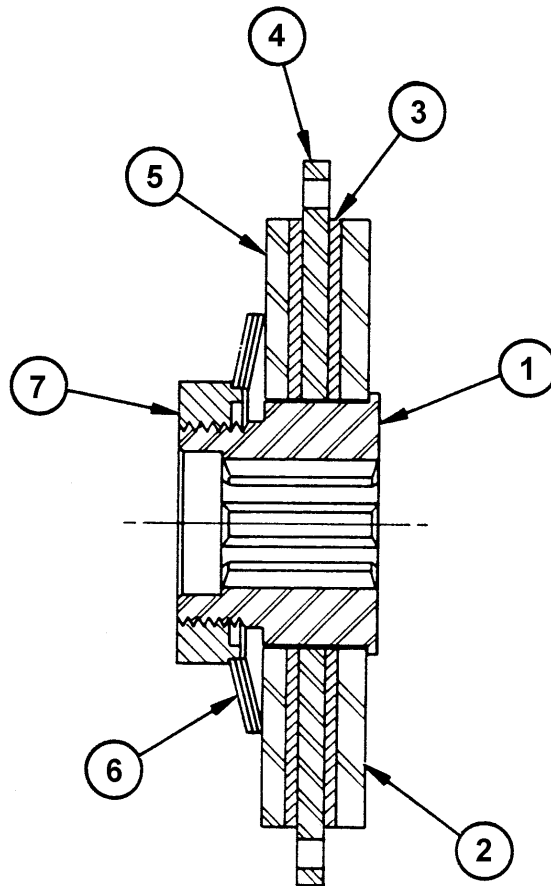

ITEM	PART NO.	QTY.	DESCRIPTION
	0731070000		TORQUE-LIMITER 3SPG
1	00748829	1	HUB
2	00748834	1	BACK PLATE
3	0731070003	2	DISK, FRICTION
4	0731070004	1	PLATE,DRIVE
5	0731070005	1	PLATE, PRESSURE
6	0731070006	3	SPRING, BELLVILLE
7	0731070007	1	NUT, ADJUSTING

WEIGHT BOX S/N 00101 - 10429 OCT 1977 - MAY 1988

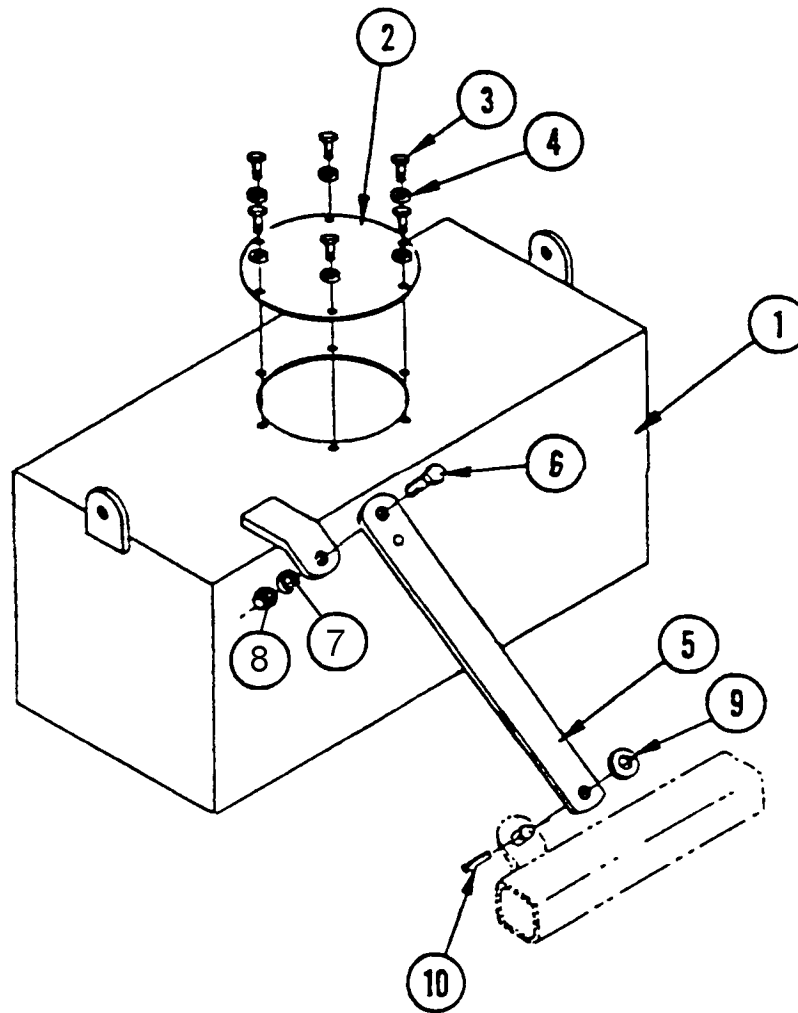

ITEM	PART NO.	QTY.	DESCRIPTION
1	0656390100	1	WEIGHT BOX WELD
2	0656390300	1	COVER
3	12BF6168	6	SCREW 3/8 X 1 NC
4	00012101	6	LOCKWASHER 3/8 PL HVY
5	00757359	1	BRACE STRAP
6	7A121016	1	C/S 3/4 X 2 NC ZP
7	00003901	1	LOCKWASHER 3/4 PL HEAVY
8	00000200	1	NUT 3/4 NC HEX PL
9	15B1200	1	WASHER 3/4 P SAE
10	20A4012E	1	PIN

WINCH AND STAND ASSEMBLY S/N 00101 - 10429 OCT 1977 - MAY 1988

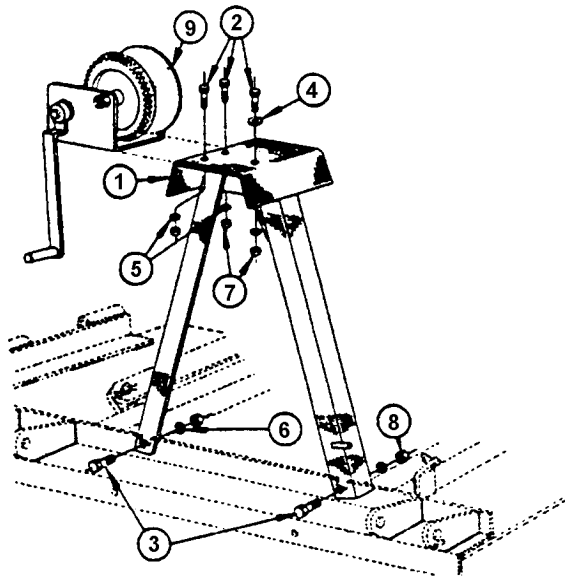

WINCH SUPPORT STAND & SAFETY BRAKE WINCH

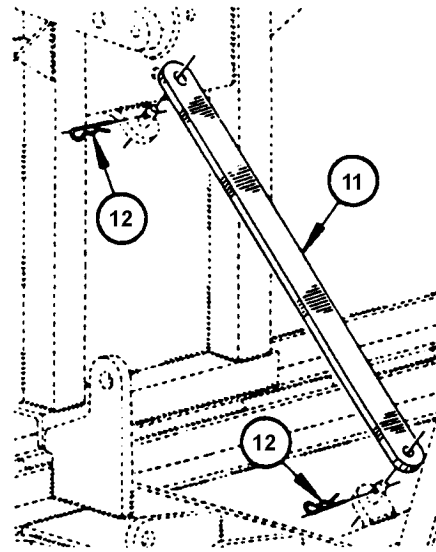

HOLD-DOWN STRAP

ITEM	PART NO.	QTY.	DESCRIPTION
1	0656200100	1	STAND WINCH FS15
2	00011400	3	HHCS 3/8 NC 1 PL5
3	00748823	2	HHCS 1/2-13UNC 1-1/2 PL5
4	15B600	1	WASHER 3/8 SAE P
5	00012101	3	LOCKWASHER 3/8 PL HVY
6	00001300	2	LOCKWASHER 1/2 PL STD
7	00013901	3	NUT HEX 3/8 NC PL
8	00001200	2	NUT,HEX 1/2 NC PL
9	B651202	1	WINCH & CABLE
10	651202	1	WINCH
11	651203	1	CABLE, 1/4 AIRCRAFT W/THIMBLE
12	65111	1	BAR, TRANSPORT
13	37107B13	2	CLIP-X HAIR PIN

Note: this winch will fit and work in place of all previous winches with no modifications.

SERVIS-RHINO

LIMITED WARRANTY

1. LIMITED WARRANTIES

- 1.01. Servis-Rhino warrants for one year from the purchase date to the original non-commercial, governmental, or municipal purchaser ("Purchaser") and warrants for six months to the original commercial or industrial purchaser ("Purchaser") that the goods purchased are free from defects in material or workmanship.
- 1.02. Manufacturer will replace for the Purchaser any part or parts found, upon examination at one of its factories, to be defective under normal use and service due to defects in material or workmanship.
- 1.03. This limited warranty does not apply to any part of the goods which has been subjected to improper or abnormal use, negligence, alteration, modification, or accident, damaged due to lack of maintenance or use of wrong fuel, oil, or lubricants, or which has served its normal life. This limited warranty does not apply to any part of any internal combustion engine, or expendable items such as blades, shields, guards, or pneumatic tires except as specifically found in your Operator's Manual.
- 1.04. Except as provided herein, no employee, agent, Dealer, or other person is authorized to give any warranties of any nature on behalf of Manufacturer.

2. REMEDIES AND PROCEDURES.

- 2.01. This limited warranty is not effective unless the Purchaser returns the Registration and Warranty Form to Manufacturer within 30 days of purchase.
- 2.02. Purchaser claims must be made in writing to the Authorized Dealer ("Dealer") from whom Purchaser purchased the goods or an approved Authorized Dealer ("Dealer") within 30 days after Purchaser learns of the facts on which the claim is based.
- 2.03. Purchaser is responsible for returning the goods in question to the Dealer.
- 2.04. If after examining the goods and/or parts in question, Manufacturer finds them to be defective under normal use and service due to defects in material or workmanship, Manufacturer will:
 - (a) Repair or replace the defective goods or part(s) or
 - (b) Reimburse Purchaser for the cost of the part(s) and reasonable labor charges (as determined by Manufacturer) if Purchaser paid for the repair and/or replacement prior to the final determination of applicability of the warranty by Manufacturer.The choice of remedy shall belong to Manufacturer.
- 2.05. Purchaser is responsible for any labor charges exceeding a reasonable amount as determined by Manufacturer and for returning the goods to the Dealer, whether or not the claim is approved. Purchaser is responsible for the transportation cost for the goods or part(s) from the Dealer to the designated factory.

3. LIMITATION OF LIABILITY.

- 3.01. MANUFACTURER DISCLAIMS ANY EXPRESS (EXCEPT AS SET FORTH HEREIN) AND IMPLIED WARRANTIES WITH RESPECT TO THE GOODS INCLUDING, BUT NOT LIMITED TO, MERCHANTABILITY AND FITNESS FOR A PARTICULAR PURPOSE.
- 3.02. MANUFACTURER MAKES NO WARRANTY AS TO THE DESIGN, CAPABILITY, CAPACITY, OR SUITABILITY FOR USE OF THE GOODS.
- 3.03. EXCEPT AS PROVIDED HEREIN, MANUFACTURER SHALL HAVE NO LIABILITY OR RESPONSIBILITY TO PURCHASER OR ANY OTHER PERSON OR ENTITY WITH RESPECT TO ANY LIABILITY, LOSS, OR DAMAGE CAUSED OR ALLEGED TO BE CAUSED DIRECTLY OR INDIRECTLY BY THE GOODS INCLUDING, BUT NOT LIMITED TO, ANY INDIRECT, SPECIAL, CONSEQUENTIAL, OR INCIDENTAL DAMAGES RESULTING FROM THE USE OR OPERATION OF THE GOODS OR ANY BREACH OF THIS WARRANTY. NOT WITHSTANDING THE ABOVE LIMITATIONS AND WARRANTIES, MANUFACTURER'S LIABILITY HEREUNDER FOR DAMAGES INCURRED BY PURCHASER OR OTHERS SHALL NOT EXCEED THE PRICE OF THE GOODS.
- 3.04. NO ACTION ARISING OUT OF ANY CLAIMED BREACH OF THIS WARRANTY OR TRANSACTIONS UNDER THIS WARRANTY MAY BE BROUGHT MORE THAN TWO (2) YEARS AFTER THE CAUSE OF ACTION HAS OCCURRED.

4. MISCELLANEOUS.

- 4.01. Proper Venue for any lawsuits arising from or related to this limited warranty shall be only in Guadalupe County, Texas.
- 4.02. Manufacturer may waive compliance with any of the terms of this limited warranty, but no waiver of any terms shall be deemed to be a waiver of any other term.
- 4.03. If any provision of this limited warranty shall violate any applicable law and is held to be unenforceable, then the invalidity of such provision shall not invalidate any other provisions herein.
- 4.04. Applicable law may provide rights and benefits to purchaser in addition to those provided herein.

KEEP FOR YOUR RECORDS

ATTENTION: Purchaser should fill in the blanks below for his reference when buying repair parts and/or for proper machine identification when applying for warranty.

Servis-Rhino Implement Model _____ Serial Number _____

Date Purchased _____ Dealer _____

ATTENTION:
READ YOUR OPERATOR'S MANUAL

RHINO[®]
1020 S. Sangamon Ave.
Gibson City, IL 60936
800-446-5158
Email: parts@servis-rhino.com





TO THE OWNER/OPERATOR/DEALER

To keep your implement running efficiently and safely, read your manual thoroughly and follow these directions and the Safety Messages in this Manual. The Table of Contents clearly identifies each section where you can easily find the information you need.

The OCCUPATIONAL SAFETY AND HEALTH ACT (1928.51 Subpart C) makes these minimum safety requirements of tractor operators:

REQUIRED OF THE OWNER:

1. Provide a Roll-Over-Protective Structure that meets the requirements of this Standard; and
2. Provide Seatbelts that meet the requirements of this paragraph of this Standard and SAE J4C; and
3. Ensure that each employee uses such Seatbelt while the tractor is moving; and
4. Ensure that each employee tightens the Seatbelt sufficiently to confine the employee to the protected area provided by the ROPS.

REQUIRED OF THE OPERATOR

1. Securely fasten seatbelt if the tractor has a ROPS.
2. Where possible, avoid operating the tractor near ditches, embankments, and holes.
3. Reduce speed when turning, crossing slopes, and on rough, slick, or muddy surfaces.
4. Stay off slopes too steep for safe operation.
5. Watch where you are going - especially at row ends, on roads, and around trees.
6. Do not permit others to ride.
7. Operate the tractor smoothly - no jerky turns, starts, or stops.
8. Hitch only to the drawbar and hitch points recommended by the tractor manufacturer.
9. When the tractor is stopped, set brakes securely and use park lock, if available.



Keep children away from danger all day, every day...



Equip tractors with rollover protection (ROPS) and keep all machinery guards in place...



Please work, drive, play and live each day with care and concern for your safety and that of your family and fellow citizens.



Free Manuals Download Website

<http://myh66.com>

<http://usermanuals.us>

<http://www.somanuals.com>

<http://www.4manuals.cc>

<http://www.manual-lib.com>

<http://www.404manual.com>

<http://www.luxmanual.com>

<http://aubethermostatmanual.com>

Golf course search by state

<http://golfingnear.com>

Email search by domain

<http://emailbydomain.com>

Auto manuals search

<http://auto.somanuals.com>

TV manuals search

<http://tv.somanuals.com>