

SHARP®

MODEL

UX-B800

FACSIMILE

OPERATION MANUAL

IMPORTANT

PLEASE KEEP THE EXTERNAL & INTERNAL PACKAGING SAFE.

PLEASE DO NOT THROW IT AWAY.

IN THE UNLIKELY EVENT OF A HARDWARE FAILURE, OUR
REPAIR CENTRE WILL ASK YOU TO PUT YOUR SHARP
FACSIMILE IN THIS BOX.

THANK YOU FOR YOUR ASSISTANCE.



MAINS PLUG WIRING INSTRUCTIONS

This equipment is fitted with a moulded type mains plug which incorporates a detachable fuse cover, under no circumstances should the plug be used without the fuse cover fitted. In the unlikely event of the socket outlet in your home not being compatible with the plug supplied, cut off the mains plug and fit an appropriate type observing the wiring code below.

DANGER: The fuse from the cut-off plug should be removed and the plug should be disposed of in a safe manner. Under no circumstances should the cut-off plug be inserted into a socket outlet as a serious electric shock may occur.

If you are not sure how to do this, get help from a qualified electrician.

IMPORTANT

The wires in this mains lead are coloured in accordance with the following code:

GREEN-AND-YELLOW:	Earth
BLUE:	Neutral
BROWN:	Live

As the colours of the wires in the mains lead of this apparatus may not correspond with the coloured markings identifying the terminals in your plug, proceed as follows: The wire which is coloured **GREEN-AND-YELLOW** must be connected to the terminal in the plug which is marked by the letter **E**, or by the safety earth symbol \perp or coloured green or green-and-yellow. The wire which is coloured **BLUE** must be connected to the terminal which is marked with the letter **N** or coloured black. The wire which is coloured **BROWN** must be connected to the terminal which is marked with the letter **L** or coloured red.

This apparatus must be protected by a 13A fuse in the mains plug or distribution board.

"WARNING: THIS APPARATUS MUST BE EARTHED"

This equipment complies with the requirements of Directive 1999/5/EC.

Dieses Gerät entspricht den Anforderungen der EU-Richtlinie 1999/5/EG.

Cet appareil est conforme aux exigences de la directive 1999/5/CE.

Este aparato satisface las exigencias de las Directiva 1999/5/CE.

Quest'apparecchio è conforme ai requisiti delle direttiva 1999/5/CE.

Dit apparaat voldoet aan de eisen van de richtlijn 1999/5/EG.

Este equipamento obedece às exigências da directiva 1999/5/CE.

Η συσκευή αυτή ανταποκρίνεται στις απαιτήσεις των οδηγιών 1999/5/ΕΚ.

Denna utrustning uppfyller kraven enligt direktiv 1999/5/EC.

Dette udstyr overholder kravene i direktiv 1999/5/EF.

Dette produktet oppfyller kravene i direktiv 1999/5/EC.

Tämä laite täyttää direktiivi 1999/5/EY.

This is a facsimile product operating in British and Irish analogue public switched telephone networks which follow the ES203021 Standard.

The Declaration of Conformity can be viewed at the following URL address.

<http://www.sharp.de/doc/UX-B800.pdf>

Table of Contents

Introduction	2	Using AUTO Mode	35
		Using MANUAL Mode	36
		Reception to Memory	37
A Look at the Operation Panel	5		
1. Installation	8	5. Making Copies	38
Unpacking Checklist	8		
Setup	8	6. Special Functions	39
Loading Paper	9	Broadcasting	39
Connecting the Power Cord	10	Caller ID (Requires Service)	41
Installing the Print Cartridge	10	Blocking Unwanted Faxes	43
Connecting the Phone Line	12	Duplex Scanning	43
Name and Fax Number	13	Fax Forward to E-mail	44
Setting the Date and Time	13	Secure Receive	46
Setting the Reception Mode	14	PBX Operations	48
Volume Adjustment	14	7. Option Settings and Print Settings	49
2. Scan to E-mail	15		
Connecting the Machine	15	8. Printing Lists	55
E-mail Settings	17	Transaction Report	56
Storing E-mail Addresses	20	9. Maintenance	57
Scan to E-mail Transmission	22	Cleaning the Machine	57
Network Settings	25	Improving Print Quality	58
3. Sending Faxes	26	10. Troubleshooting	61
Transmittable Documents	26	Problems and Solutions	61
Loading the Document	26	Messages and Signals	64
Resolution and Contrast	27	Clearing Paper Jams	67
Sending a Fax: Normal Dialling	28	Quick Reference Guide	68
Sending a Fax: Auto Dialling	29		
Batch Page Numbering	34	Index	69
Sending a Fax From Memory	34		
4. Receiving Faxes	35		
TEL/FAX Mode	35		

Introduction

Specifications

Print cartridge yield ^{1,2}	Replacement cartridge: SHARP UX-C80B Ink Save mode ON: Approx. 800 A4 pages Ink Save mode OFF: Approx. 480 A4 pages (The initial cartridge has the same yield as the above replacement cartridge.)
Paper tray capacity	Approx. 200 A4 sheets (60 to 80g/m ²) (At room temperature; maximum stack height should not be higher than the line on the tray)
Recording system	Thermal inkjet
Print resolution	600 × 600 dpi
Effective printing width	203 mm max.
Scan to E-mail	Yes; requires an Internet connection and a router, switch, or hub to connect the machine. LAN cable (10Base-T straight-through cable) must be purchased separately. LAN interface: 10Base-T IEEE802.3
File formats	Tiff (G4), PDF (G4)
Memory capacity ²	Approx. 250 average pages (Approx. 100 pages when Secure Receive is on)
Modem speed	14,400 bps with auto fallback to lower speeds.
Transmission time ²	Approx. 6 seconds
Compatibility	ITU-T (CCITT) G3 mode
Compression scheme	MR, MH, MMR
Storable transmission destinations	Rapid Keys: 36 A, B, C keys: 3 (e-mail only) Speed Dial numbers: 63
Telephone function	Yes (cannot be used if power fails)
Effective scanning width	208 mm max.

¹Ink Save mode is initially turned off. To turn on Ink Save mode, see pages 49 and 53.

²Based on Sharp Standard Chart at standard resolution, excluding time for protocol signals (i.e., ITU-T phase C time only).

Reception modes	AUTO, MANUAL, TEL/FAX
Applicable telephone line	Analog public switched telephone network (ES203021) / PBX
Automatic document feeder	A4: 20 sheets max. (60 - 80 g/m ² paper; temperature: 18 - 28°C; humidity: 45 - 65% RH)
Input document size	Automatic feeding: Width: 148 to 210 mm Length: 140 to 297 mm Manual feeding: Width: 70 to 210 mm Length: 140 to 356 mm
Scanning Resolution	Standard: 203 x 98 dpi Fine: 203 x 196 dpi Super fine: 203 x 391 dpi Halftone: 203 x 196 dpi
Halftone (grayscale)	64 levels
Contrast control	Automatic/Dark selectable
Copy function	Single/Multi/Sort (99 copies/page)
Display	LCD display, 20 digits x 2 lines
Power requirements	230 V AC, 50 Hz
Power consumption	Standby: 6.0 W, Maximum: 40 W
Operating temperature	15 - 32°C
Humidity	25 - 80% RH
Dimensions (without attachments)	Width: 380 mm Depth: 280 mm Height: 156 mm
Weight (without attachments)	Approx. 4.4 kg

As a part of our policy of continuous improvement, SHARP reserves the right to make design and specification changes for product improvement without prior notice. The performance specification figures indicated are nominal values of production units. There may be some deviations from these values in individual units.

Important: This machine is not designed for use on a line which has call waiting, call forwarding, or certain other special services offered by your telephone company (errors may occur during transmission and reception of faxes).

This machine is not compatible with digital telephone systems.

Important safety information

Do not disassemble this machine or attempt any procedures not described in this manual. Refer all servicing to qualified service personnel.

Do not install or use the machine near water, or when you are wet. For example, do not use the machine near a bath tub, wash bowl, kitchen sink or laundry tub, in a wet basement, or near a swimming pool. Do not spill any liquids on the machine.

Unplug the machine from the power outlet and telephone socket and consult a qualified service representative if any of the following situations occur:

- Liquid has been spilled into the machine or the machine has been exposed to rain or water.
- The machine produces odors, smoke, or unusual noises.
- The power cord is frayed or damaged.
- The machine has been dropped or the housing damaged.

Do not allow anything to rest on the power cord, and do not install the machine where people may walk on the power cord.

This machine must only be connected to a 230 V AC, 50 Hz, earthed (3-prong) outlet. Connecting it to any other kind of outlet will damage the machine.

Never insert objects of any kind into slots or openings on the machine. This could create a risk of fire or electric shock. If an object falls into the machine that you cannot remove, unplug the machine and consult a qualified service representative.

Do not place this machine on an unstable cart, stand or table. The machine could be seriously damaged if it falls.

Never install telephone wiring during a lightning storm.

Never install telephone sockets in wet locations unless the socket is specifically designed for wet locations.

Never touch bare telephone wires or terminals unless the telephone line has been disconnected at the network interface.

Use caution when installing or modifying telephone lines.

Avoid using a telephone (other than a cordless type) during an electrical storm. There may be a remote risk of electric shock from lightning.

Do not use a telephone to report a gas leak in the vicinity of the leak.

The power outlet must be installed near the equipment and must be easily accessible.

A Look at the Operation Panel

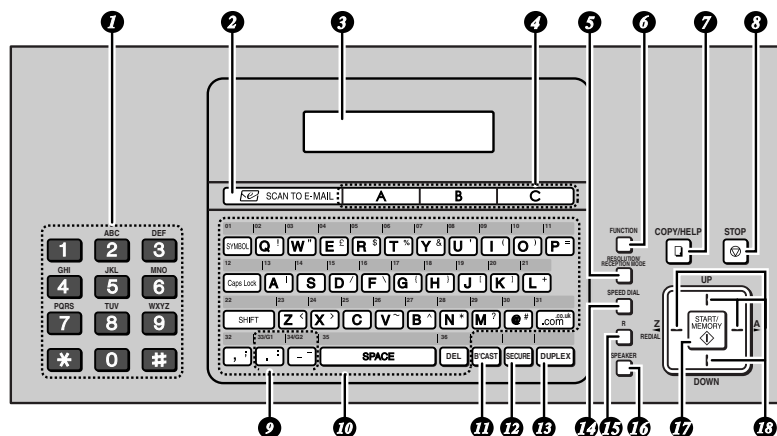

Note: Affix the Rapid Key labels as shown above.

- 1 Number keys:** Use to dial numbers.
- 2 SCAN TO E-MAIL key:** Press to send a document to an e-mail recipient.
- 3 Display:** This displays messages to help you operate the machine.
- 4 A, B, C keys:** An e-mail address can be stored in each key for one-touch selection (p. 20).
- 5 RESOLUTION/RECEPTION key**
When a document is in the feeder, press to adjust the scanning resolution (p. 27). At any other time, press to select the reception mode (p. 14).
- 6 FUNCTION key:** Press this key followed by the arrow keys to select special functions and settings.
- 7 COPY/HELP key**
When a document is in the feeder, press to make a copy (p. 38). At any other time, press to print the Help List.
- 8 STOP key:** Press to cancel an operation before it is completed.
- 9 Group Keys:** Multiple fax or e-mail destinations can be stored in each key for one-touch selection (p. 40).
- 10 Rapid Keys / letter keys:** A fax number or e-mail address can be stored in each of these keys for one-touch selection (attach the Rapid Key labels). When entering text, the keys are used as letter keys.
- 11 BROADCAST key:** Press to send to multiple fax or e-mail destinations (p. 39).
- 12 SECURE key:** Press to use the fax secure receive function (p. 46).
- 13 DUPLEX SCAN key:** Use to scan two-sided documents for transmission and copying (p. 43).
- 14 SPEED DIAL key:** Press to select a fax or e-mail destination stored in a 2-digit Speed Dial number (pp. 20, 29).

15 R key: If you are on a Flash-type PBX, use this key to dial out (page 28).

16 SPEAKER key: Press to listen to the line and fax tones through the speaker when faxing (p. 28).
Note: **This is not a speakerphone.** It cannot be used for speaking.

17 START/MEMORY key: Press after dialling to send a fax (p. 28). Press before dialling to send a fax through memory (p. 34). Press in the date and time display to show the percentage of memory currently used.

18 Arrow keys: Use to scroll through and select settings, and to search for stored destinations (pp. 22, 32).

Letter keys

Use these keys when the display prompts you to enter a name, e-mail address, or other text.

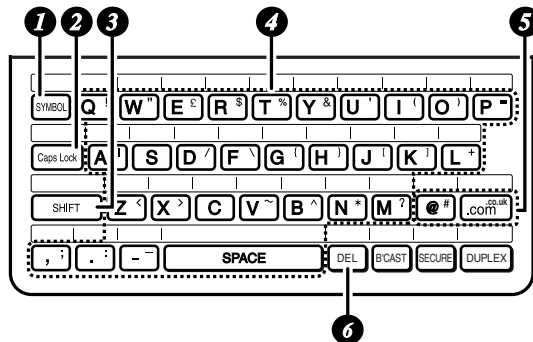



1 SYMBOL key: Press to enter a symbol (the character appearing on the right side of each letter key). Press again to return to normal letter entry mode.

2 Caps Lock key: Press to enter upper case letters. Press again to return to lower case letter entry.

3 SHIFT key: Hold down to temporarily change case.

4 Letter keys: Use to enter letters.



5 @key, .com key: Press to conveniently enter "@" and ".com" when entering an e-mail address.

6 DEL key: Press to delete the character marked by the cursor. When the cursor is to the right of a line of text, press to backspace and clear characters. (The cursor can be moved by pressing  or .) To delete all entered characters, hold down until all characters are cleared.

Monitoring phone conversations

When speaking through the handset, you can press  to allow a third person to listen to the conversation through the speaker. (To turn off the speaker, press the key again.)

To adjust the volume of the speaker when monitoring a conversation,

press  or  (the volume reverts to the lowest setting each time the handset is replaced).

Note that **the speaker cannot be used for speaking**; it is only for listening.

To avoid feedback (a loud howling sound), be sure to turn off the speaker (press  once again) before you replace the handset.

1. Installation

Unpacking Checklist

Paper tray Document exit tray Received document tray Handset cord



Phone line cord Print cartridge Rapid Key labels Manual Setup guide



Extension phone adapter

Points to keep in mind when setting up

- ◆ Do not place the machine in direct sunlight.
- ◆ Do not place the machine near heaters or air conditioners.
- ◆ Keep dust away from the machine.
- ◆ Keep the area around the machine clear.

About condensation

If the machine is moved from a cold to a warm place, condensation may form on the scanning glass, preventing proper document scanning. To remove the condensation, turn on the power and wait approximately two hours before using the machine.

Setup

Remove the packing tape

- 1 Open the cover (1) and remove the tape (2). (Do not install the print cartridge yet.)

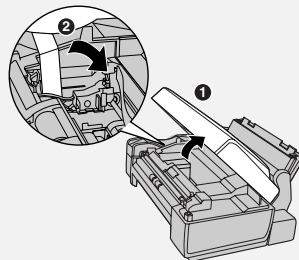

- 2 Close the cover.

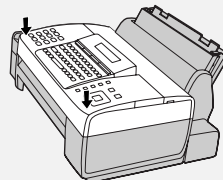

Connect the handset

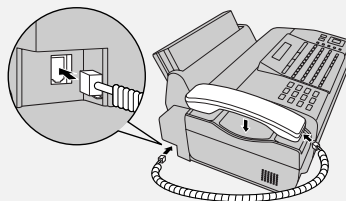

Attach the trays

Attach the received document tray

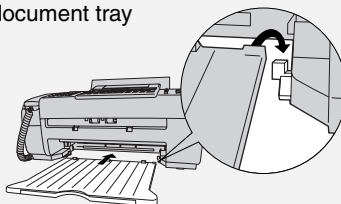

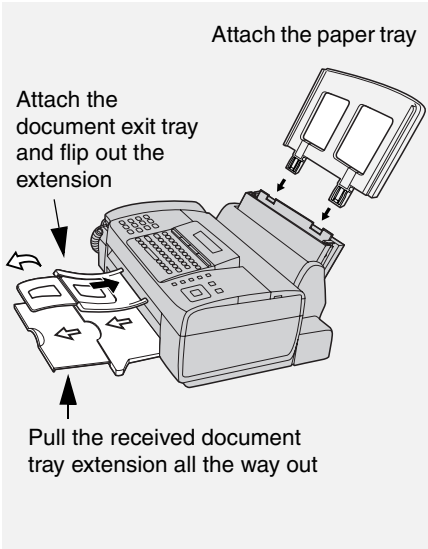

Loading Paper

Approximately 200 sheets of A4-size paper (60 - 80 g/m²) can be loaded in the paper tray (at room temperature; maximum stack height should not be higher than the line on the tray).

- 1 Fan the paper, and then tap the edges against a flat surface to even the stack.

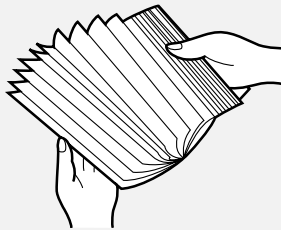

- 2 Pull the paper plate forward and insert the stack of paper into the tray, **print side up**.

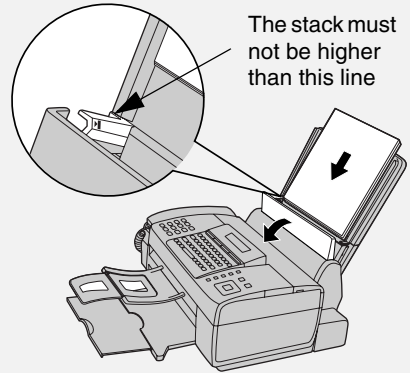

- If paper remains in the tray, take it out and combine it into a single stack with the new paper.
- Printing on the reverse side of the paper may result in poor print quality.
- Do not use paper that has already been printed on or is curled.
- Remove received faxes and other printed output before about 50 sheets accumulate in the received document tray (otherwise the sheets may scatter).

If at any time the display shows **[ADD PAPER &] / [PRESS START KEY]**, check the paper tray. If the tray is empty, add paper. If there is paper in the tray, take it out and then reinsert it.

When finished, press



Connecting the Power Cord

Connecting the Power Cord

Plug the power cord into a 230 V, 50 Hz, earthed (3-prong) AC outlet.

- ◆ The power outlet must be installed near the equipment and must be easily accessible.

Caution! Remove all packing tape before plugging in the power cord (see page 8), or damage to the machine may result.

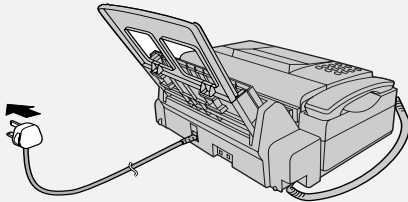

The display will show **[CHECK CARTRIDGE]** until you install the print cartridge.

- ◆ It is recommended that you install surge protectors for the power and telephone lines. Surge protectors can be purchased at most telephone specialty stores.

Installing the Print Cartridge

Print cartridge yield

SHARP UX-C80B replacement cartridge

Ink Save mode OFF:

Approx. 480 A4 pages

Ink Save mode ON:

Approx. 800 A4 pages

(The initial cartridge has the same yield as the replacement cartridge.)

- ◆ Ink Save mode is initially turned off. To turn on Ink Save mode, see pages 49 and 53.

Caution! Do not open the cover while the machine is printing.

Note: Keep print cartridges sealed in their packages until you are ready to install them. It is recommended that you do not use a cartridge that has been left unused for a long time after opening, as the print quality may be considerably degraded.

- ◆ Make sure the machine's power cord is plugged in and paper is loaded in the paper tray.

- 1 Open the cover (grasp the finger grip).

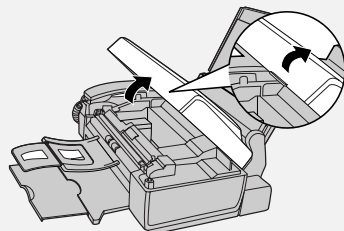

Installing the Print Cartridge

If the display shows **[PRINTER ERROR]** or **[PRINTER ERROR/CHECK PAPER]**, open the cover and check for jammed paper. Remove any jammed paper (see page 67) and close the cover.

2 Remove only the tape from the new cartridge.

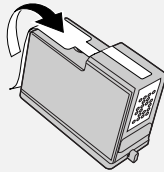

- **Make sure all tape is removed.**

- **CAUTION!** **DO NOT** touch the gold contact area on the cartridge.

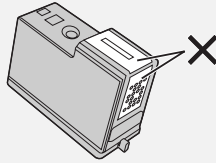

3 Make sure the cartridge holder is in the position shown. Place your fingers on top of the holder and open the holder release.

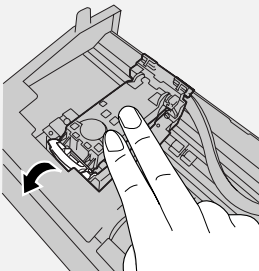

- **CAUTION! DO NOT** touch the gold contact area or pull on the cable.

- If you are replacing the cartridge, remove the old cartridge. If you are going to use the old cartridge again, place it in an air-tight container (containers for this purpose can be purchased at most office supply stores).

4 Insert the new print cartridge (1). Close the holder (2), making sure it clicks into place.

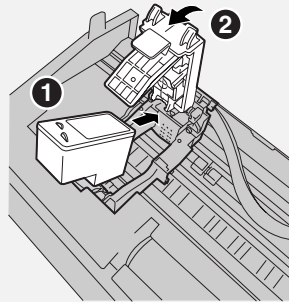

5 Close the cover, pressing firmly on both front corners.

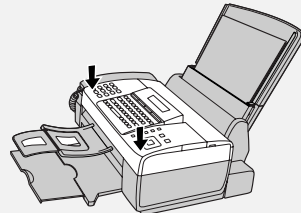

Display: **[CHANGE CARTRIDGE]/**
[1=NEW, 2=OLD].

6 Press **1** (**NEW**) if the cartridge you installed is new.
Display: **[NEW CARTRIDGE?]/**
[OK:PRESS START]

Press **2** (**OLD**) if the cartridge you installed is old.

7 Press .

If you selected "OLD" in the previous step, this completes the installation procedure. (Note: If you find that print quality is not satisfactory, see p. 58 to align the print cartridge.)

Connecting the Phone Line

If you selected "NEW", the machine will print an alignment page. Continue with the steps below.

8 In the alignment page, locate the line that is closest to a straight line.

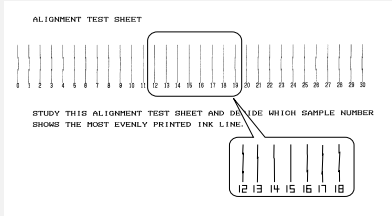

In this example, "15" is closest to a straight line.

9 Enter the number of the straightest line with the number keys.

- To clear a mistake, press .

10 Press .

The machine is initially set to print high quality images, which require more ink. If you prefer to use less ink and speed up drying time, change the "INK SAVE MODE" setting to "ON" (pp. 49 and 53).

When the resolution is set to HALF TONE, the machine is initially set to print at a slower printing speed to enable higher quality images. When using HALF TONE, if you prefer faster printing at the expense of slightly reduced image quality, change the "QUALITY MODE" setting to "NO" (pp. 49 and 53).

Connecting the Phone Line

Insert one end of the line cord into the socket on the back of the machine marked **TEL. LINE**. Insert the other end into a wall telephone socket.

TEL. LINE
socket

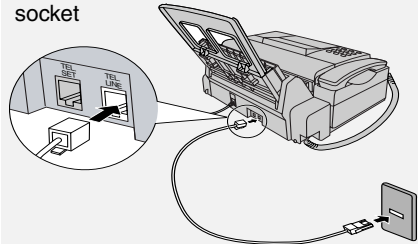

Standard wall socket

Extension phone (optional)

If desired, you can connect an extension phone to the machine.

Remove the seal covering the **TEL. SET** socket and connect the extension phone line to the socket using the provided adapter.

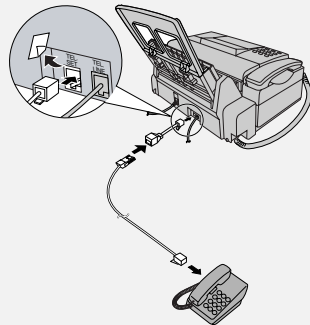

- ◆ **Eire:** Insert the extension phone line directly into the **TEL. SET** socket (do not use the adapter).



Name and Fax Number

Enter your name and fax number.

- ◆ Your entered name and fax number will be printed automatically at the top of all fax pages you send.

1 Press , then  until [ENTRY MODE] appears.

2 Press .
Display: [OWN NUMBER SET]

3 Press . [ENTER FAX #]

4 Enter your fax number with the number keys (max. 20 digits).

- To insert a space, press . To enter "+", press .
- To clear a mistake, press .

5 Press .

6 Enter your name using the letter keys (max. 24 characters).
Example: SHARP

- To clear a mistake, press .
- For information on using the text entry keys, see page 6.



7 Press . [DATE&TIME SET]



8 Press  to exit.

Setting the Date and Time

Set the date and time.

- ◆ The date and time will be printed automatically at the top of all fax pages you send. The date and time also appear in the display.



1 Press , then  until [ENTRY MODE] appears.

2 Press , then  until [DATE&TIME SET] appears.

3 Press .



- The currently set date appears (example): [DATE 15-08-2006]

4 Enter a two-digit number for the day ("01" to "31").

Example: the 5th  
[DATE 05-08-2006]

- To correct a mistake, press  to move the cursor back to the mistake and enter the correct number.

5 Enter a two-digit number for the month ("01" for January, "02" for February, "12" for December, etc.).

Example: January  
[DATE 05-01-2006]

6 Enter the year (4 digits).

Example:    

Setting the Reception Mode

- The currently set time appears (example): [TIME 12:19]

7 Enter a two-digit number for the hour ("00" to "23") and a two-digit number for the minute ("00" to "59").
Example: 9:25

0 **9** **2** **5**

8 Press  . [ANTI JUNK #]

9 Press  to exit.

Setting the Reception Mode

The machine has three modes for receiving incoming faxes:

AUTO mode:

The machine automatically answers all calls on two rings and begins fax reception.

MANUAL mode:

All calls, including faxes, must be answered by picking up the machine's handset or an extension phone connected to the same line.

TEL/FAX mode:

The machine automatically answers all calls on four rings. If the machine detects that a call is a voice call (including a manually dialed fax), it makes a special ringing sound to alert you to answer. If the machine detects that the call is an automatically dialed fax, it begins reception automatically.

To set the reception mode, make sure a document **is not loaded in the document feeder**, and then press



 until the desired mode appears in the display.

For more information on receiving faxes, see Chapter 4.

Volume Adjustment



Speaker volume

1 Press  .

2 Press  or  to select **HIGH, MIDDLE, or LOW.**

- Press  again to turn off the speaker.

Ringer volume

1 Press  or  to select **HIGH, MIDDLE, LOW, or OFF.**

(Make sure  has not been pressed, the handset is not lifted, and a document is not loaded in the feeder.)

- The ringer will ring once at the selected level.

2 If you selected "OFF OK ?" to turn

off the ringer, press  .

2. Scan to E-mail

The Scan to E-mail feature lets you scan a document and directly send the image to an e-mail recipient.

- ◆ This saves you the trouble of scanning the document into a computer and sending the scanned file using an e-mail program.
- ◆ The scanned document is sent as an attachment to an e-mail message. The attached file can be in TIFF or PDF format.

Requirements

To use Scan to E-mail, you must

- ◆ Have an Internet connection.
- ◆ Have a broadband router or LAN switch/hub through which you can connect the machine to the Internet (the router is usually connected to a cable modem or DSL modem).

A typical setup is shown below.

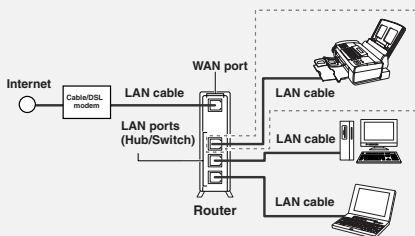

Note: The Scan to E-mail function is not compatible with mail servers that require security protection (SSL).

Connecting the Machine

The machine is connected using an Ethernet cable (not included). Please purchase a straight-through (regular) cable that supports 10Base-T.

Connect one end of the cable to the LAN port on the machine.

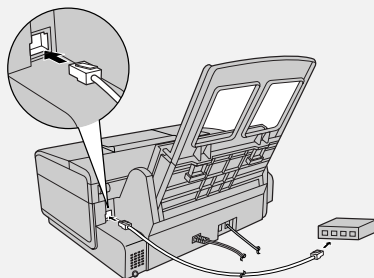

Connect the other end to a LAN port on your router, switch, or hub.

- ◆ If you are uncertain which port to connect the cable to, see the manual for the router, switch or hub.
- ◆ The connections can be made with all devices powered on.
- ◆ For other questions about how the machine should be connected, consult your Internet service provider.

Connecting the Machine

IP address

The machine requires an IP address to communicate on the Internet.



If your network is set up to automatically assign IP addresses, you do not need to do anything; the machine will automatically receive an IP address when it is connected.

Automatic assignment of IP addresses is normally performed by a DHCP server, which may be a computer, router, or other device on the network. (Most routers used on home networks contain a DHCP server.)

If your network requires that a static (permanent) IP address be assigned to the machine, see *Network Settings* on page 25 to enter the IP address and related information.

Checking your IP address and the connection

To check the machine's IP address and verify that the machine is able to communicate on the network, follow these steps.

1 Press  , then  until **[NETWORK SETTING]** appears.

2 Press  , then  to show **[NETWORK INFORMATION]**

3 Press  .

- If the machine has automatically received an IP address and is able to communicate, **[IP ADDRESS/DHCP: ON]** will appear on the top line of the display, followed by the IP address on the bottom line. To show the machine's host name, press



- If a static IP address has been entered in the machine and the machine is able to communicate, **[IP ADDRESS/DHCP: OFF]** will appear on the top line of the display, followed by the IP address on the bottom line. To show the machine's

host name, press  .

- If the machine was unable to receive an IP address automatically, or if the router locked up after the machine received an IP address, **[IP ADDRESS/DHCP: FAIL]** / **[192.168. 1 .201]** will appear. "192.168. 1 .201" is an IP address that is assigned to the machine for diagnostic purposes when connection fails (it cannot be used for regular communication).
- If a cable has not been connected, **[CHECK CABLE]** will appear.
- If **[NOW CONNECTING / CHECK LATER]** appears, press  to exit, wait briefly, and then repeat the procedure again.

If the machine is unable to communicate...

- ◆ Check the Ethernet cable. Are the connections secure? Are you using straight-through (not crossover) cable that supports 10Base-T?
- ◆ There may be a problem in the router or other device to which the machine is connected. Try removing and then restoring the power to the router (see the manual for the router).
- ◆ If [**IP ADDRESS/DHCP: FAIL**] appears, remove and then reinsert the Ethernet cable plug, and repeat the procedure to check the machine's IP address. If the same message appears, check the device that acts as the DHCP server on your network (try removing and restoring the power). If your router is your DHCP server, make sure that DHCP is enabled in the router settings. If your network does not have a DHCP server, set a static IP address as explained on page 25.
- ◆ If a static IP address has been set, make sure that the network settings (page 25) are correct .

E-mail Settings

Before the Scan to E-mail function can be used, you must configure the e-mail settings.

The e-mail settings specify your outgoing mail server, as well as your sender name, sender address, and other items that appear in the e-mail message to which scanned image files are attached.

- ◆ It is easiest to configure the e-mail settings in the machine's Web page. The machine's Web page can be accessed from any computer on the same network as the machine.
- ◆ The e-mail settings can also be configured using the machine's operation panel.

Note: If your Internet service provider requires that you configure "SMTP Authentication" or "POP before SMTP" settings, you must use the Web page.

If you do not know your SMTP server name or the settings that are required, ask your Internet service provider.

E-mail Settings

Accessing the machine's Web page

To access the Web page, you will need to know the machine's host name or IP address (usually it is most convenient to use the host name).

To check the machine's host name or IP address, follow the procedure in *Checking your IP address and the connection* (page 16), or print the Network Settings List (page 55).







Type in the host name or IP address of the machine in the Address bar of the Web browser on your computer.

The Web page menu will appear. Select **E-mail Setup** and configure the settings. For explanations of the settings, click **Help** in the Web page menu.

Note: If the Web page is used while the machine is in operation (except for voice calls using the handset), machine operation may become unstable.

Using the machine's operation panel to configure the settings





Follow the steps below to display the e-mail settings, and then configure each setting as explained in the table on the next page.

- 1 Press  , then  until **[E-MAIL SETTING]** appears.
- 2 Press  , then  repeatedly until the setting that you wish to configure appears.
- 3 Press  . (Note: This step is not necessary for the "FILE FORMAT" setting.)
- 4 Enter the required information for the setting as explained in the table on the next page.
- 5 After configuring the setting, the next e-mail setting will appear in the display. You can configure the next setting, or press  to exit.

E-mail settings

Enter the required information for each setting as explained below. This is done in step 4 of the procedure on the previous page.

- ◆ The sender address and SMTP server settings are required. The other settings are optional.
- ◆ Use the letter keys to enter text. For information on using the letter keys, see page 6.
- ◆ The e-mail subject, e-mail message, and file format that you enter below are default settings. They will be used if you do not specify these items at the time of transmission.

Setting	Description
SENDER NAME	Enter the sender name that will appear in the e-mail message (max. of 50 characters). When finished, press  .
SENDER ADDRESS	Enter your sender e-mail address (max. of 128 characters). When finished, press  . (Note: Be sure to enter your actual e-mail address. Return e-mail and undelivered mail reports will be sent to this address. In addition, some SMTP servers reject outgoing e-mail if a valid sender e-mail address is not entered.)
E-MAIL SUBJECT	Enter a default subject (max. of 128 characters). When finished, press  .
E-MAIL MESSAGE	Enter a default message (max. of 256 characters). When finished, press  .
FILE FORMAT	This sets the default format of the file that is created when you scan a document. Press 1 for TIFF or 2 for PDF. Initial setting: TIFF
SMTP SERVER	Enter the host name or IP address of your outgoing (SMTP) mail server (max. of 60 characters). When finished, press  .

Storing E-mail Addresses

Storing E-mail Addresses

You can store e-mail addresses in the **A**, **B**, and **C** keys, in Rapid Keys, and in Speed Dial numbers.



- ◆ An e-mail address stored in a Rapid Key or the **A**, **B**, or **C** key is selected by simply pressing that key. A total of 36 Rapid Keys are available. (Note: Attach the Rapid Key labels as shown on page 5.)
- ◆ An e-mail address stored in a Speed Dial number is selected by pressing  and entering the 2-digit Speed Dial number. A total of 63 Speed Dial numbers are available.

Note: Rapid Keys and Speed Dial numbers are also used for fax (p. 29).

Storing an e-mail address

Follow the steps below to store an e-mail address using the machine's operation panel.

- ◆ E-mail addresses can also be stored using the machine's Web page. To access the Web page, see page 18.

- 1 Press , , then .
- 2 To store an e-mail address in the **A**, **B**, or **C** key, press the desired key and go directly to Step 4.
To store an e-mail address in a Rapid Key, press the desired Rapid Key.

To store an e-mail address in a Speed Dial number, press  and enter the desired 2-digit number (01 to 63).

- If you prefer to have the machine suggest an available Rapid Key / Speed Dial number at the end of the procedure, press .

3 Press  to select E-MAIL.
Display: [E-MAIL # MODE]

4 Enter the e-mail address with the letter and number keys (max. of 128 characters).

- For information on using the letter keys, see page 6.
- To clear a mistake, press .

5 Press .

6 Enter the name of the recipient (max. 20 characters).

7 Press .

- If you selected a Rapid Key or Speed Dial number in Step 2, the display will briefly show [STORED], and then [NEW NUMBER]. Go to Step 8.

- If you did not select a Rapid Key or Speed Dial number in Step 2, the display will show the next available Rapid Key or Speed Dial number. If that number is acceptable, press



and go to Step 8. If not, press the desired Rapid Key, or press the

A, B, or C key, or press  and enter the desired 2-digit Speed Dial number, and go to Step 8.



- 8** Return to Step 2 to store another e-mail address, or press  to exit.

Editing and clearing stored e-mail addresses

To make changes to a previously stored e-mail address, or to clear an address, follow these steps:



1 Press , , then .

2 Press the key in which the address is stored (Rapid Key or **A, B, or C** key), or press  and enter the 2-digit Speed Dial number in which the address is stored.

(You can also press  or  until the name or address appears



and press .)

Display: [1=EDIT, 2=CLEAR]

3 Press  for EDIT or  for CLEAR.

- If you selected CLEAR, go to Step 8.

4 If you selected EDIT, make the desired changes to the address.

- Press  or  to move the cursor to the character(s) you wish to change, and then press the appropriate letter or number key. The new character will replace the old character.

- If you do not wish to change the address, go directly to Step 5.

5 Press .

6 Make the desired changes to the name.

- If you do not wish to change the name, go directly to Step 7.

7 Press .

8 Return to Step 2 to edit or clear

another address, or press  to exit.

Scan to E-mail Transmission

Scan to E-mail Transmission

Follow the steps below to send a document to an e-mail recipient.

- ◆ The document will be sent as an attachment to an e-mail message.
- ◆ You can specify the recipient by directly entering an e-mail address, or by selecting an address that has been stored as explained in the previous section.

1 Flip up the feeder cover (❶) and adjust the document guides to the width of your document (❷).

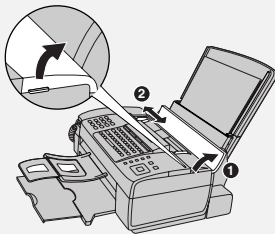

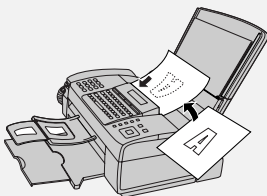

2 Insert the document face down with the top edge going in first. Up to 20 A4-size sheets can be placed in the feeder at once.

- For more information on loading the document, see page 26.

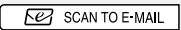

- If desired, press  to set the resolution and contrast (see p. 27).

3 Enter the destination e-mail address using one of the following methods:



- Press , press , and enter the address with the letter and number keys (p. 6). When finished, press .

- If the address has been stored in the **A**, **B**, or **C** key, press the key.

- If the address has been stored in a Rapid Key, press the Rapid Key.

- If the address has been stored in a Speed Dial number, press  and enter the Speed Dial number.

- To search for a stored address, press  (this eliminates stored fax numbers from the search),

press  or  until the name or address appears, and press



Note: If [**CHECK E-MAIL SETTING**] appears, your SMTP server or sender address has not been entered in the e-mail settings (p. 17).

4 If you need to select or change any of the e-mail options, press



and follow Steps 5 and 6 below. (Note that settings selected here are temporary. To make permanent changes, see p. 17.)

If you do not wish to change the e-mail options, go directly to Step 7.

- To exit the e-mail options, press

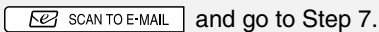

and go to Step 7.

5 Press or until the desired option appears, and press (is not necessary for the FILE FORMAT setting). Change the option as explained below (use the letter keys to enter text and to delete text; p. 6).

- E-MAIL SUBJECT:** Enter a subject (max. 128 characters). When

finished, press .

- E-MAIL MESSAGE:** Enter a message (max. 256 characters).

When finished, press .

- FILE FORMAT:** Press for TIFF or for PDF. (Make sure the recipient has an image viewer that can show images in the selected format.)

- FILE NAME:** Enter a name for the scanned file (max. 40 characters).

When finished, press .

(If a file name is not entered, the name “UXB800-yymmddhhmmss”, where “yymmddhhmmss” is the year, month, day, hour, minute, and second the file was created, is automatically assigned.)

- 6** When you have finished configuring the e-mail options, press

. (If the display shows **[PRESS START TO SCAN]**, it is not necessary to press

.)

- 7** Press to begin transmission.

Note: The recipient may have security settings in their e-mail program or virus protection software that prevent the file attachment from being received or opened. In this case, ask the recipient to try changing the settings.

Sending a message only

You can also send a short e-mail message without including a document. Perform Steps 3 through 7 of the above procedure (enter the message in Step 5). After Step 7, **[SEND W/O DOCUMENT?] / [1=YES,2=NO,W/T DOC.]**

will appear. Press to select “YES”. The message will be sent.

Scan to E-mail Transmission

Error messages

If transmission is not successful because the machine is unable to connect to your mail server, one of the following error messages will appear.

[CONNECTION ERROR]

This appears when communication does not take place correctly on your local network, usually due to a problem with the cable connections. Make sure that the cable ends are securely inserted in the LAN ports. Make sure that the correct cable is being used and that the cable is good. Make sure that your router or hub is powered on.

[SERVER ERROR]

This appears when the machine cannot connect to your mail server or there is no response from the mail server. Make sure the SMTP server setting is correct (p. 19). If you have configured "SMTP Authentication" settings or "POP before SMTP" settings in the machine's Web pages, make sure these settings are correct (p. 17).

[SERVER NOT FOUND] / [SMTP]

This appears when an incorrect host name is entered for your SMTP server. Check the SMTP server setting (p. 19).

[SERVER ERROR] / [SMTP-AUTH]

This appears when your SMTP server requires SMTP authentication and the SMTP authentication user name or password entered in the machine's Web page is not correct (p. 17).

[SERVER NOT FOUND] / [DHCP]

This appears when the machine is unable to automatically obtain an IP address. Restart your router or other device that acts as your DHCP server.

[CABLE DISCONNECTED]



This may appear below any of the above messages. Check the same items as in [CONNECTION ERROR] above.

If an undelivered mail report is sent to inform you that your e-mail message was not successfully delivered, the report will be sent to the sender address entered in the e-mail settings (page 17).

Network Settings



If your network requires that you assign a static (permanent) IP address to the machine, follow the steps below to disable DHCP (automatic IP address assignment) and configure the network settings.

- Consult your network administrator for the information that must be entered. After DHCP is disabled, the settings that must be configured appear in the following order (these settings only appear when DHCP is set to NO):
IP ADDRESS
SUBNET MASK
DEFAULT GATEWAY
DNS (PRIMARY)
DNS (SECONDARY)

1 Press , then  until [NETWORK SETTING] appears.

2 Press  twice. [DHCP] will appear.

3 Press  for NO (the machine will not obtain an IP address automatically).

- [IP ADDRESS] will appear. (If you wish to configure a different setting, press  or .)

4 Press .

5 Press the number keys to enter the required number.

- Three digits must be entered in each segment of the number (the segments are separated by periods). If a segment does not have 3 digits, enter zeros as needed.
Example: IP address = 192.168.1.2
You must enter: 192.168.001.002

- If you make a mistake, press  to move the cursor to the mistake and enter the correct number.

6 When finished entering the number,

press .



7 The next setting will appear in the display. Repeat Steps 4 through 6 to configure the next setting, or press



 to exit.

Initializing the network settings

If you need to return the network settings to their initial state, follow the steps below.

- Initializing the settings enables DHCP and clears the IP address and related settings.

1 Press , then  until [NETWORK SETTING] appears.

2 Press  twice, then  to show [INITIALIZE SETTINGS].

3 Press  twice.

3. Sending Faxes

Transmittable Documents

Minimum document size/weight

Loading up to 20 sheets at once:

148 x 140 mm

52 g/m²

Loading 1 sheet at a time:

70 x 140 mm

52 g/m²

Maximum document size/weight

Loading up to 20 sheets at once:

A4 (210 x 297 mm)

80 g/m²

Loading 1 sheet at a time:

210 x 356 mm

157 g/m²

The maximum scanning width is 208 mm, and the top and bottom 4 mm of a document cannot be scanned.

Other restrictions

- ◆ The scanner cannot recognise yellow, greenish yellow, or light blue ink.
- ◆ Remove all clips, staples, and pins before loading documents in the feeder (these will damage the machine).
- ◆ Ink, glue, or correcting fluid on a document must be dry before scanning.
- ◆ Documents which are taped, torn, smaller than the minimum size, carbon backed, easily smudged, or

have a slick, coated surface should be photocopied, and the copy loaded in the feeder.

- ◆ Documents that are curled or have a wave-like pattern must be flattened.

Loading the Document

Up to 20 A4-size sheets can be placed in the feeder at once (18 - 28°C, 45% - 65% RH humidity). (If the sheets do not feed or double feeds occur, reduce the number of sheets.) The sheets will feed automatically starting from the bottom sheet.

- ◆ To send or copy more than the maximum number of sheets, place the additional sheets gently in the feeder just before the last sheet is scanned. Do not force the sheets in, as this may cause double-feeding or jamming.
 - ◆ For large or thick sheets that must be loaded one at a time, insert each sheet into the feeder as the previous sheet is being scanned. Insert gently to avoid double-feeding.
- 1** Flip up the feeder cover (❶) and adjust the document guides to the width of your document (❷).

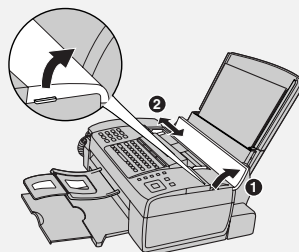

- 2** Place the document face down with the top edge going in first, and insert it all the way into the feeder. Make sure that the roller draws the document in.

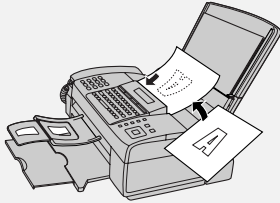

- Display: **[READY TO SEND]** .

- 3** Adjust the resolution and/or contrast settings (p. 27), and then dial the receiving machine (p. 28).

Removing a document from the feeder

- 1** Open the cover (❶) and remove the document (❷).
- **Caution:** Attempting to remove a document without opening the cover may damage the feeder mechanism.

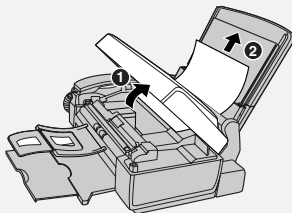

- 2** Close the cover, pressing down firmly on both front corners.

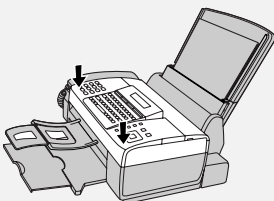

Resolution and Contrast

You can adjust the resolution and contrast before sending a document.

- ◆ The default resolution setting is **STANDARD**. The default contrast setting is **AUTO**.
- ◆ Adjust the settings each time you don't want to use the default settings.

Note: The resolution and contrast settings are only effective for sending; not for receiving.

Resolution settings

- STANDARD** Use **STANDARD** for ordinary documents. This provides the fastest transmission.
- FINE** Use **FINE** for documents containing small letters or fine drawings.
- SUPER FINE** Use **SUPER FINE** for documents containing very small letters or very fine drawings.
- HALF TONE** Use **HALF TONE** for photographs and illustrations. The original will be reproduced in 64 shades of gray.

Contrast settings

- AUTO** Use **AUTO** for normal documents.
- DARK** Use **DARK** for faint documents.

Sending a Fax: Normal Dialling

1 Load the document(s).

- The resolution/contrast cannot be adjusted unless the document is loaded.

2 Press  one or more times until the desired resolution and contrast settings appear in the display.

- The first time you move through the list of resolution settings, the contrast setting AUTO will appear next to each resolution setting. The second time you move through the list, the contrast setting DARK will appear.

Note: In order to transmit in SUPER FINE resolution, the receiving machine must also have that resolution. If not, your machine will automatically step down to FINE.

If you prefer to use FINE for the default resolution setting, change the "FINE PRIORITY" setting (p. 49).

Sending a Fax: Normal Dialling

With Normal Dialling, you pick up the handset (or press ) and dial by pressing the number keys.

- ◆ If a person answers, you can talk with them through the handset before sending the fax.

- ◆ Normal Dialling allows you to listen to the line and make sure the other fax machine is responding.

1 Load the document(s).

- If desired, press  to set the resolution and/or contrast.

2 Pick up the handset or press . Listen for the dial tone.

3 Dial the fax number of the receiving machine (press the number keys).

- If you are on a Flash-type PBX and are dialling out, press , wait for the connection to the outside line, and then dial the number.

4 Wait for the connection. You will either hear a fax tone or the other person will answer.

- If the other person answers, ask them to press their Start key (if you pressed , pick up the handset to speak with them). The receiving machine will issue a fax tone.

5 When you hear the fax tone, press



. Replace the handset.

- If the transmission is completed successfully, the machine will beep once.



- If an error occurs, the machine will beep three times and print a Transaction Report to inform you of the problem (p. 56).

Note: If the transmission is unsuccessful and the display shows **[DOCUMENT JAMMED]**, remove the document as explained on page 67.

Sending a Fax: Auto Dialling

You can store your most frequently dialled fax and phone numbers in Rapid Keys and Speed Dial numbers.

- ◆ A number stored in a Rapid Key is dialled by simply pressing the Rapid Key. A total of 36 Rapid Keys are available. (Note: Attach the Rapid Key labels as shown on page 5.)

- ◆ A number stored in a Speed Dial number is dialled by pressing  , the 2-digit Speed Dial number, and then  . A total of 63 Speed Dial numbers are available.

Note: E-mail addresses can also be stored in Rapid Keys and Speed Dial numbers (see page 20).

Storing fax and phone numbers

Follow the steps below to store a fax or phone number using the machine's operation panel.

- ◆ Fax/phone numbers can also be stored using the machine's Web page. To access the Web page, see page 18.

1 Press  ,  , then  .

- 2** To store a number in a Rapid Key, press the desired Rapid Key. To store a number in a Speed Dial number, press  and enter the desired 2-digit number (01 to 63). Display: **[SELECT DEST. TYPE]**

- If you prefer to have the machine suggest an available Rapid Key / Speed Dial number at the end of the procedure, press  .

3 Press  to select "FAX". Display: **[FAX # MODE]**



4 Enter the fax or phone number with the number keys (max. of 32 digits). (Note: A space cannot be entered.)

- To clear a mistake, press  .

Sending a Fax: Auto Dialling

- If a pause is required between any of the digits to access a special service

or an outside line, press  . The pause appears as a hyphen (two seconds per pause). Several pauses can be entered in a row.

- If you are on a Flash-type PBX and are storing a number for an outside line, press , press  to insert a pause, and then enter the fax or voice number. (When you dial the auto-dial number, you will automatically dial out without the need to press the  key.)

- If you are on a PBX that requires dialling a number to dial out and are storing a number for an outside line, enter the number, press  to insert a pause, and then enter the number of the receiving machine. (When you dial the auto-dial number, you will automatically dial out without the need to dial the number for an outside line.)

5 Press  .

6 Enter the name of the destination (max. 20 characters).

- For information on using the letter keys, see page 6.

7 Press  .

- If you selected a Rapid Key or Speed Dial number in Step 2, the display will briefly show [**STORED**], and then [**NEW NUMBER**]. Go to Step 8.
- If you did not select a Rapid Key or Speed Dial number in Step 2, the display will show the next available Rapid Key or Speed Dial number. If that number is acceptable, press



and go to Step 8. If not, press the desired Rapid Key, or press



and enter the desired 2-digit Speed Dial number, and go to Step 8.





8 Return to Step 2 to store another number, or press  to exit.

- To confirm that an auto-dial number has been stored correctly, print out the Destination List as explained on page 55.



Editing and clearing auto-dial numbers

To make changes to a previously stored auto-dial number, or clear a number, follow these steps:

1 Press , , then .



2 Press the Rapid Key (or press  and enter the 2-digit Speed Dial number) of the number that you want to edit or clear. (You can also press  or  until the number appears and press .)

Display: [1=EDIT, 2=CLEAR]

3 Press  for "EDIT" or  for "CLEAR".



- If you selected "CLEAR", go to Step 7.

4 If you selected "EDIT", make the desired changes to the number.

- Press  or  to move the cursor to the digit or digits you wish to change, and then enter the new digit. The new digit will replace the old digit.
- If you do not wish to change the number, go directly to Step 5.

5 Press .

6 Make the desired changes to the name.

- Press  or  to move the cursor to the letter or letters you wish to change, and then press the appropriate letter key. The new letter will replace the old letter.
- If you do not wish to change the name, go directly to Step 7.

7 Press .

8 Return to Step 2 to edit or clear

another number, or press  to exit.

Using an auto-dial number to send a fax

1 Load the document(s).

If desired, press  to set the resolution and/or contrast.

2 Select the fax number using one of the methods below:

- **Rapid Key Dialling:** If the number is stored in a Rapid Key, press the Rapid Key.

Sending a Fax: Auto Dialling



- **Speed Dialling:** If the number is stored in a Speed Dial number, press



and enter the Speed Dial number with the number keys. Make sure the correct destination appears

in the display (if not, press ) , and

then press .

- **Search Dialling:** Press  or  until the name or number of the other party appears in the display, and press .



3 Dialling and transmission will take place automatically.

- To cancel transmission, press .
- If the transmission is completed successfully, the machine will beep once.
- If an error occurs, the machine will beep three times and print a Transaction Report to inform you of the problem (p. 56).

Making a voice call with an auto-dial number

Rapid Key Dialling: Lift the handset and press the Rapid Key.

Speed Dialling: Lift the handset, press , and enter the 2-digit Speed Dial number with the number keys.

Search Dialling: Press  or  until the name or number of the other party appears, and lift the handset. (You can also lift the handset first, search for the number, and then press



Sending a fax by Direct Keypad Dialling



Use this method to dial a full fax number without using the handset .

1 Load the document(s).

- If desired, press  to set the resolution and/or contrast.

2 Enter the number of the receiving machine with the number keys.

- If a pause is required between any of the digits to access a special service or an outside line, press  . The pause will appear as a hyphen (two seconds per pause). Several pauses can be entered in a row.

- If you are on a Flash-type PBX and are dialling out, press , press  to insert a pause, and then enter the number of the receiving machine.
- If you are on a PBX and must dial a number to dial out, enter the number, press  to insert a pause, and then enter the number of the receiving machine.

3 Check the display. If the number

shown is correct, press .

- If the number is not correct, press  to clear the incorrect digits, and then re-enter the correct digit(s).

Redial

You can automatically redial the last number dialled on the machine.

1 Load the document(s).

- If desired, press  to set the resolution and/or contrast.

2 Press  once. Make sure the display shows the number you wish to dial.

3 If you are sending a fax, press

. Dialling begins.

If you are making a phone call, lift the handset. Dialling begins.

Note: If the transmission is unsuccessful and [**DOCUMENT JAMMED**] appears in the display, remove the document as explained on page 67.

Automatic redialling

If you use auto dialling (including Direct Keypad Dialling) to send a fax and the line is busy, the machine will automatically make three redial attempts at intervals of five minutes.

During this time, [**RECALLING**] will appear in the display, followed by the attempt number. You will not be able to dial any other locations while the message appears.

- ◆ To clear the message and stop automatic redialling, press .

Under certain conditions, automatic redialling may stop before three redialling attempts are made.

Batch Page Numbering

Batch Page Numbering

Use this feature to add a slash and the total number of pages to each page number on transmitted fax pages (for example, "P. 1/5", "P.2/5", etc.). This allows the recipient to check for missing pages.

1 Load the document(s).

2 Press , then  to show [PAGE COUNTER].

3 Press .

Display: [ENTER # (01 - 99)]

4 Enter the total number of pages ("01" to "99") with the numeric keys.

Example: 5 pages  .

5 If desired, press  to set the resolution and/or contrast.

6 Dial the receiving machine and send the fax.

- To cancel a batch number entry, remove the document from the

feeder or press .

- If the number of pages actually transmitted is not the same as the batch number entered, an alarm will sound and [PAGE COUNT ERROR] will appear in the display. "PAGE E." will also appear in the **NOTE** column of the Transaction Report if printed.



Sending a Fax From Memory

To increase transmission speed, you can send a fax through the machine's memory. After transmission, the fax is automatically cleared from memory.



Note: If a power failure occurs while sending a fax from memory, you must repeat the operation.



To send a fax through memory, load the document, press , and dial using one of the methods below. (Note that an e-mail destination cannot be selected.)

◆ Press a Rapid Key.

◆ Press , enter a 2-digit Speed Dial number, and press .

◆ Enter the fax number with the number keys and press .

◆ Press  repeatedly to select an auto-dial number and press .

◆ Press  once to select the last number dialled and press .

If [MEMORY FULL] appears, see *If the memory becomes full* on page 40.

4. Receiving Faxes

TEL/FAX Mode

To select TEL/FAX mode, press

RESOLUTION/
RECEPTION MODE



(with no document in the feeder) until [TEL/FAX] appears in the display.

When the reception mode is set to TEL/FAX, the machine automatically answers all calls on four rings (the number of rings is fixed). After answering, the machine monitors the line for about five seconds to see if a fax tone is being sent.

- ◆ If the machine detects a fax tone (this means that the call is an automatically dialed fax), it will automatically receive the fax.
- ◆ If your machine doesn't detect a fax tone (this means that the call is a voice call or manually dialed fax), it will make a special ringing sound for 15 seconds to alert you to pick up the machine's handset (to change the number of seconds, see p. 49 and "PSEUDO RING DURATION" on p. 50). If you don't answer within this time, the machine will send a fax tone to the other machine to allow the calling party to send a fax manually.

Note: Only the machine will make the special ringing sound. An extension phone will not ring after the machine initially answers the call.

Using AUTO Mode

To select AUTO mode, press

RESOLUTION/
RECEPTION MODE



(with no document in the feeder) until [AUTO] appears in the display.

In AUTO mode, the machine automatically answers all calls on two rings and receives incoming faxes.

- ◆ If you pick up the handset before the machine answers, you can talk to the other party and receive a fax as explained in *Using MANUAL Mode* on page 36.

To change the number of rings on which the machine answers calls in AUTO mode, change the "NUMBER OF RINGS" setting (p. 49).

The machine automatically reduces received faxes as needed to fit the paper. If you prefer to have all faxes printed at full size, change the "RECEIVE RATIO" setting (pp. 49 and 53).

Using MANUAL Mode

Using MANUAL Mode

To select MANUAL mode, press

RESOLUTION/
RECEPTION MODE



(with no document in the feeder) until **[MANUAL]** appears in the display.

In MANUAL mode, you must answer all calls (even faxes) by picking up the machine's handset or an extension phone connected to the same line.

Answering with the machine's handset

Important: If a document is loaded in the machine's feeder, remove it before performing the steps below.



- 1 When the machine rings, pick up the handset.
- 2 If you hear a fax tone, wait until the display shows **[RECEIVING]** and then replace the handset.
- If **[RECEIVING]** does not appear (or if you have set the Fax Signal Receive setting to NO (pp. 49, 51)),

press  to begin reception.

- 3 If the other party first speaks with you and then wants to send a fax, press  after speaking. (Press before the sender presses their Start key.)
- When **[RECEIVING]** appears in the display, hang up.

Answering with an extension phone

Important: If a document is loaded in the machine's feeder, remove it before performing the steps below.

- 1 Answer the extension phone when it rings.
- 2 If you hear a soft fax tone, wait until the machine responds (the extension phone will go dead), then hang up.
- 3 If the machine doesn't respond, or if the other party first talks to you and then wants to send a fax, press  once and  twice on the extension phone (only on a tone dial phone). This signals the machine to begin reception. Hang up.
- The above step is necessary if you have set the "FAX SIGNAL RX" setting to NO (pp. 49 and 51).
- To use a number other than "5" to start fax reception, change the "FAX REMOTE #" setting (see page 49).

Reception to Memory

Incoming faxes will be received to memory when printing is not possible, such as when the machine runs out of paper, the print cartridge needs replacement, or the paper jams.

When you have received a fax in memory, **[FAX RX IN MEMORY]** will appear in the display, alternating with a message that indicates the problem.

When you resolve the problem, the stored faxes will automatically print out.

- ◆ If you received faxes to memory because the machine ran out of paper, be sure to add paper that is the same size as the paper previously used, or the fax print-out size will not match the size of the printing paper.

Memory capacity

When Secure Receive is activated (p. 46), the number of pages that can be held in memory is approximately 100. The pages will be retained in memory even if the power is turned off or a power failure occurs.

When Secure Receive is not activated, the number of pages that can be held in memory is approximately 250.

Caution: When Secure Receive is not activated, any faxes held in memory will be erased if the power is turned off or a power failure occurs.

- ◆ If faxes held in memory are erased, a CLEAR REPORT will print when the power is restored. This provides information about the erased faxes, including the fax numbers of the transmitting machines if available.

Note: If 100 pages or more are stored in memory (the display shows 40% or

higher memory use when  is

pressed), fax and e-mail transmission may not be possible. Transmission will be possible after the faxes in memory are printed out.

5. Making Copies

The machine can be used as a convenience copier. Follow the steps below to make copies.

Sorting copies

The machine is initially set to not sort copies. If you wish to have copies sorted as shown below, change the "SORT COPY" setting to YES (pp. 49 and 53).

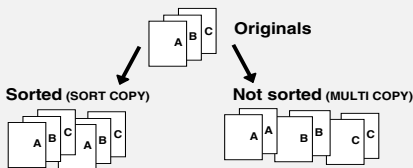

Example: Two copies each of three originals

1 Load the document(s). (Maximum of 20 A4-size sheets.)

- If desired, press  to set the resolution and/or contrast.

2 Select the following copy settings as needed:

- **Enlarge/reduce:** Press  or



to select 100%, 125%, 135%, 200%, 70%, 88% or 94%.
Default setting: 100%.

- **Number of copies per original:**

Enter a number from 1 to 99.
Default setting: 1

Example: Press  for two copies

3 When you are ready to begin copying, press .

If [MEMORY FULL] appears...

If you place many originals in the feeder, the memory may become full before all pages can be scanned (the display will show [MEMORY FULL]). If this happens, only the pages that were scanned will be copied and the remaining pages will automatically feed out. Repeat the copy procedure for the remaining pages, including the page that was being scanned when the memory became full.

Note: It may not be possible to make a copy of an original if a high resolution setting is used and/or the original contains so much detailed content that the memory becomes full before scanning finishes.

6. Special Functions

Broadcasting

You can send the same document to as many as 20 fax or e-mail destinations in just one operation.

- ◆ The destinations must be all fax or all e-mail. It is not possible to mix fax and e-mail destinations.
- ◆ Only destinations stored in Rapid Keys and Speed Dial numbers can be selected. (It is not possible to enter a full fax number or e-mail address.)







1 Load the document(s).

- If desired, press  to set the resolution and/or contrast.

2 Press .

3 Press to broadcast to FAX destinations, or to broadcast to E-MAIL destinations.

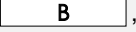
4 Select a destination using one of the following methods:



- Press a Rapid Key.
- Press  and enter a 2-digit Speed Dial number.
- Press  or  until the desired destination appears in the display.
- Press , , or  (only for an e-mail destination).

5 Press to enter the destination.

6 Repeat Steps 4 and 5 for each of the other desired destinations (maximum of 20).

- You can press  to scroll through and check your entered destinations. To delete a destination, press  when it appears.

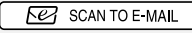
7 When you have finished selecting destinations, press .

- If you are broadcasting to fax destinations, transmission will begin.
- If you are broadcasting to e-mail destinations, you can press  to select e-mail options (see Steps 4 to 6 on page 23). When you are ready to begin transmission, press .
- For fax, a Transaction Report is automatically printed out after Broadcasting is completed. If any destinations in the "Note" column of the report are marked "Busy" or have a communication error code, you will need to send the document to those destinations again.

Broadcasting

If the memory becomes full...

If the memory becomes full during scanning, [MEMORY FULL] will appear in the display.

- ◆ Press  to send the pages which have been stored up to that point in memory (the remaining pages will automatically feed out). After transmission, the memory will be cleared and you can send the remaining pages. You will also need to send the page which was being scanned when the memory filled up.

- ◆ To cancel the entire transmission,

press .



Broadcasting using a Group Key

If the destinations to which you want to broadcast have all been stored in one Group Key (see *Storing numbers in Group Keys* which follows), you can perform the broadcast operation using the following simplified procedure:



1 Load the document(s).

- If desired, press  to set the resolution and/or contrast.

2 Press the appropriate Group Key

 or .

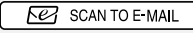

- If the group is a fax group, transmission will begin.

- If the group is an e-mail group, you can press  to select e-mail options (see Steps 4 to 6 on page 23). When you are ready to begin transmission, press .



Storing destinations in Group Keys

Follow the steps below to store a group of destinations in a Group Key.

- ◆ Rapid Keys 33/G1 and 34/G2 can be used as Group Keys. A key cannot be simultaneously programmed as both a Group Key and a Rapid Key.
- ◆ Up to 20 fax or e-mail destinations can be stored in one Group Key.
- ◆ The destinations must be all fax or all e-mail. It is not possible to mix fax and e-mail destinations.
- ◆ Only Rapid Key and Speed Dial numbers can be stored in a Group Key. Full numbers cannot be stored.

1 Press , then  until [ENTRY MODE] appears.

2 Press , then  until [GROUP ENTRY] appears.



3 Press  (SET) to store a group. (Press  (CLEAR) to clear a group.)

- If [GROUP SPACE FULL] appears, both keys have already been

Caller ID (Requires Service)







programmed. Clear one of the keys and then store a group.

4 Press the Group Key that you want

to use ( or ). (If you are clearing a Group Key, press the Group key that you want to clear and go to Step 8.)



- If **[ALREADY STORED]** or **[RAPID # STORED]** appears, the key has already been programmed. Clear the key or try the other Group Key.

5 Select a destination using one of the following methods:

- Press a Rapid Key.
- Press  and enter a 2-digit Speed Dial number.
- Press  or  until the desired destination appears in the display.
- Press , , or  (only for an e-mail destination).

6 Press to enter the destination.

7 Repeat Steps 5 and 6 for each of the other desired destinations (maximum of 20).

- You can press  to scroll through and check your entered destinations. To delete a destination, press  when it appears.

8 When you have finished entering

the destinations, press .

9 Press to exit.

Caller ID (Requires Service)

Important: To use this function, you must subscribe to a Caller ID service from your phone company. The machine may not be compatible with some Caller ID services.

If you subscribe to a Caller ID service, you can have the machine show the name and number of the caller when you receive a call.

1 Press , then until **[OPTION SETTING]** appears.

2 Press , then until **[CALLER-ID]** appears.

3 Press (YES) to turn on Caller ID. (To turn off Caller ID, press and go to Step 7.)

4 Press to exit.

Caller ID (Requires Service)

Note: Some caller ID services may not provide the name of the caller. In this case, only the phone number will appear when you receive a call.

Display messages

One of the following messages will appear while the machine rings if caller information is not available.

NO SERVICE	No caller information was received. Make sure that your service has been activated.
CALLER-ID ERROR	Noise on the telephone line prevented reception of caller information.
OUT OF AREA	The call was made from an area which does not have Caller ID service, or the service is not compatible with your service.
PRIVATE CALL	Caller information was not provided at the caller's request.



Caller ID list

The machine keeps a log of the most recent 30 calls and faxes you have received (the Caller ID list). You can view the list and automatically dial a number from the list.

- ◆ The list is only available if you have Caller ID service and have turned on the Caller ID function.
- ◆ After you have received 30 calls, each new call will delete the oldest call.

- ◆ The Caller ID list can also be printed. See page 55.

1 Press  until [**<REVIEW CALLS>**] appears.

2 Press  or  to scroll through the list.

- To exit the list, press .

3 To dial a number, display the number and:

- **Fax:** Load the document and press



. Transmission will begin.

- **Voice call:** Pick up the handset. Dialling will begin automatically.

Deleting calls from the list

To delete a single call from the list, display the call and press .

To delete all calls from the list, hold  down for 3 seconds while viewing any number in the list.









Blocking voice calls

If you have turned on Caller ID, the Anti Junk Fax function will block voice calls as well as faxes from your specified Anti Junk Number (see page 43).

Blocking Unwanted Faxes

The Anti Junk Fax function blocks reception of faxes from a fax number that you specify.

To use this function, enter the fax number that you want to block. Only one number can be entered.

- 1 Press  , then  until [ENTRY MODE] appears.
- 2 Press  , then  until [ANTI JUNK #] appears.
- 3 Press  (SET) to store an Anti Junk number.
(To clear a previously stored number, press  (CLEAR) and go to Step 5.)
- 4 Enter the number with the number keys (max. 20 digits).
- 5 Press  .
- 6 Press  to exit.
 - When a fax is blocked (or when a voice call is blocked if you are using the Caller ID function), a transaction report (page 56) will print to inform you (unless “TRANSACTION LIST” on page 50 is set to “NEVER PRINT”).



Duplex Scanning

Duplex Scanning is convenient for transmitting or copying two-sided documents. When this function is selected, you simply feed all pages of the document through the machine once, turn the stack of pages over, and feed the stack through again. The machine will automatically sort the pages into the correct order (front of 1st page, back of 1st page, front of 2nd page, back of 2nd page, etc.).

- ◆ Note that any blank sides must be included when scanning the pages (if the number of pages is not equal each time the machine scans the stack, an error will result).

- 1 Load the documents. Make sure the pages are placed front-side down, with the first page on the bottom.

- If desired, press  to set the resolution and/or contrast.

- 2 Press  and then  .
- 3 Perform all steps of the desired copy or transmission operation.
- 4 When all pages of the document have been scanned, turn the stack over (do not change the page order) and load the stack again.
- 5 Press  .

Fax Forward to E-mail

Fax Forward to E-mail



You can have incoming faxes from specified fax numbers (or all fax numbers) automatically converted to e-mail and forwarded to designated e-mail recipients.



- ◆ This provides a convenient means of forwarding received faxes to someone who is out of the office.
- ◆ This function can also be used to send copies of all received faxes to an administrator for centralized document storage.

Storing (or clearing) groups of originating fax numbers and forwarding e-mail addresses

To use the Fax Forward to E-mail function, you must first store one or more groups of originating fax numbers and forwarding e-mail addresses.

- ◆ One originating fax number and one forwarding e-mail address can be stored in each group. When a fax is received, the machine will check each stored group, and if the originating number of the received fax matches a fax number in one of the groups, the machine will forward the fax to the e-mail address in that group.
- ◆ You can also omit entry of an originating fax number in a group and have faxes from all originating fax numbers forwarded to the e-mail address.
- ◆ Up to 10 groups can be stored.

1 Press  , then  until [RCV FAX TO E-MAIL] appears.

2 Press  , then  to show [FORWARDING ADDRESS] / [1=SET, 2=CLEAR]

3 Press  to select "SET".

- To clear a previously stored group, press  .

4 Enter a 2-digit number from "01" to "10" (this number is used to identify the group you will store).

- If you are clearing a group, enter the 2-digit number of the group you wish to clear and go to Step 8.

5 Enter the originating fax number. Enter without "+" or spaces.

- If you wish to have faxes from all originating fax numbers forwarded, go directly to Step 6 without entering a fax number.

6 Press  .

7 Enter the e-mail address to which you wish to have the faxes forwarded.

- For information on using the letter keys, see page 6.



8 Press  .

9 Return to Step 4 to store (or clear)

another group, or press  to exit.

Activating (and deactivating) Fax Forward to E-mail

After you have stored one or more Fax Forward to E-mail groups, follow the steps below to activate the Fax Forward to E-mail function.

1 Press , then  until [RCV FAX TO E-MAIL] appears.

2 Press .



3 Press  to select "ON".



- To turn off Receive Fax to E-mail, press .



4 Press  to exit.

Printing forwarded faxes

The machine is initially set to not print received faxes that are forwarded. If you want the machine to print forwarded faxes, follow the steps below.

1 Press , then  until [RCV FAX TO E-MAIL] appears.



2 Press , then  until [PRINT RECEIVED FAX] appears.

3 Press  to select YES (print forwarded faxes) or  to select NO.



4 Press  to exit.

Printing a report

The machine is initially set to print a fax forwarding report only when a forwarding error occurs. If you would like the machine to print a report each time it forwards a received fax, follow the steps below.

1 Press , then  until [RCV FAX TO E-MAIL] appears.

2 Press , then  until [REPORT SETTING] appears.

3 Press  (PRINT ERROR ONLY) to print a report only when an error occurs, or  (ALWAYS PRINT) to print each time a fax is forwarded.

4 Press  to exit.

Secure Receive

Secure Receive



To prevent others from viewing or taking your received faxes, use the Secure Receive function. When this function is activated, received faxes are held in memory without being printed. To print the faxes, a 4-digit "secure code" must be entered.

Note: When Secure Receive activated, the number of pages that can be held in memory is approximately 100. (When Secure Receive is not activated, approximately 250 pages can be held.)

Setting a secure code

The secure code is used to print received faxes. Follow the steps below to set a secure code.

- The secure code can be any 4-digit number.

1 Press , then  until [SECURE # SET] appears.

2 Press .

3 Enter a 4-digit secure code.

4 Press .

- The machine will print the secure code for your records.
- Take care not lose the print-out or forget the code. In the event that you forget the code and have kept no record, contact your dealer or nearest SHARP service centre.

Activating Secure Receive

Follow the steps below to activate Secure Receive.

- Secure Receive cannot be activated unless a secure code has been set.

1 Press , then  until [ACTIVATE SECURE RCV.] appears.

2 Press .

3 Press  to select "YES".

4 Press  to exit.

Printing received faxes

When the memory is holding one or more received faxes, [RECEIVED SECURE FAX] will appear in the display. Follow the steps below to print the faxes.

1 Press  until [SECURE DATA PRINT] appears.

2 Press .



3 Enter the 4-digit secure code.

4 Press .

- Printing will begin.
- If the wrong code is entered, [WRONG SECURE #] will appear. Go back to Step 3.

Deactivating Secure Receive

If you need to deactivate Secure Receive (faxes will be automatically printed when received), follow the steps below.

1 Press , then  until [ACTIVATE SECURE RCV.] appears.

2 Press .

3 Press  to select "NO".

4 Enter the 4-digit secure code.

5 Press .

- The display will briefly show [NO SELECTED] and then the date and time.
- If the wrong code is entered, [WRONG SECURE #] will appear. Go back to Step 4.

Clearing the secure code

To clear the secure code, follow the steps below.

- Secure Receive must be deactivated before you can clear the secure code.

1 Press , then  until [SECURE # CLEAR] appears.

2 Press .

3 Enter the 4-digit secure code.

4 Press .

- The display will briefly show [CLEARED] and then the date and time.
- If the wrong code is entered, [WRONG SECURE #] will appear. Go back to Step 3.

PBX Operations

PBX Operations

If the machine is connected to a PBX, you can use it to perform the following operations:

Making enquiry calls: During a call, you can put the original caller on hold, make a further call to a third party, and then go back to the original caller.

Transferring calls: You can transfer a call to another number on the same PBX without operator assistance.

Making enquiry calls

- 1** During the telephone conversation, press ^R. This puts the original caller on hold.
- 2** When you hear the dial tone, dial the number of the third party for the enquiry call.
- 3** When you have finished the enquiry call, you will be automatically returned to the original caller as soon as the third party hangs up.

Transferring calls



- 1** During the telephone conversation, press ^R. This puts the original caller on hold.
- 2** When you hear the dial tone, dial the number to which you want to transfer the call. When the other party answers, hang up, and the call will be transferred.
 - If the other party does not answer, press ^R again to return to the original caller.



7. Option Settings and Print Settings

The option settings and print settings allow you to customize the operation of the machine to better suit your needs.

The option settings are related to general operation. The print settings are related to printing.

The option settings and print settings have been initially configured at the factory. To change a setting, follow the steps below to display the desired setting, and then change the setting as explained in the tables that follow.

1 Press  , then  until [OPTION SETTING] or [PRINT SET-UP] appears.

2 Press , then  repeatedly until the desired setting appears.

- The option settings and print settings are described in the tables below and on the following pages.



3 Enter a selection for the setting by pressing the number keys as explained in the table.

4 After entering a selection, the subsequent option/print setting will appear in the display. To exit the

settings, press .

Option Settings

Make a selection for the displayed setting as explained below. This is done in step 3 of the above procedure.

Setting	Description
FINE PRIORITY	This is used to change the default resolution for faxing from STANDARD to FINE. Press  (YES) to select FINE, or  (NO) to select STANDARD. Initial setting: NO (STANDARD)
NUMBER OF RINGS	This is used to set the number of rings on which the machine answers calls when the reception mode is set to AUTO. Enter any number from 2 to 5 . Initial setting: 2 rings.
FAX REMOTE #	This is used to set the number that is pressed (followed by  twice) on an extension phone to start fax reception. Enter any number from 0 to 9 . Initial setting: 5

Option Settings

TRANSACTION LIST	<p>This sets the condition for printing transaction reports (see page 56). Press a number key as follows:</p> <ul style="list-style-type: none">1 (ALWAYS PRINT): Print after every fax transmission, reception and error.2 (ERROR/MEMORY): Print only after an error or memory operation.3 (SEND ONLY): Print after every fax transmission.4 (ERROR ONLY): Print only when an error occurs.5 (NEVER PRINT): Never print. <p>Initial setting: ERROR ONLY</p>
PSEUDO RING DURATION	<p>This sets the duration of the special ringing sound that alerts you to voice calls and manually dialled faxes in TEL/FAX reception mode. Press a number key as follows:</p> <ul style="list-style-type: none">1 15 seconds2 30 seconds3 60 seconds4 120 seconds <p>Initial setting: 15 seconds</p>
FLASH SELECT	<p>This setting is used when the machine is connected to a PBX and the PBX uses the "Flash" method to connect to an outside line.</p> <p>Press 1 (SHORT TIME) if your PBX line is a normal line, or 2 (LONG TIME) if your PBX is a high-speed line.</p> <p>Note: This setting is normally only used in Germany. In other countries, you can try changing the setting if you encounter difficulty with the default setting.</p>

<p>FAX SIGNAL RX</p>	<p>The machine will automatically begin reception if you hear a soft fax tone after answering a call on the machine's handset or an extension phone. If you use a computer fax modem to send documents on the same line, you must turn this function off in order to prevent the machine from mistakenly attempting to receive documents from the computer fax modem. Press 1 (YES) to turn on the the automatic reception function, or 2 (NO) to turn off the function. If you select NO, you must start reception manually by pressing  on the machine each time you hear a soft fax tone after answering a call. Initial setting: YES</p>
<p>CALLER-ID</p>	<p>If you subscribe to a Caller ID service from your phone company, use this setting to have the ID of the caller appear in the display each time you receive a call. For more information, see page 41. Initial setting: NO</p>
<p>AUTO PRINT OUT</p>	<p>Press 1 (YES) to have the machine automatically print an Activity Report once every 30 send/receive operations. (The report can still be printed manually at any time.) Press 2 (NO) to turn off Auto Print Out. Initial setting: NO</p>
<p>ECM MODE</p>	<p>Press 1 (YES) to have any distortions in a transmission due to noise on the telephone line automatically corrected before print-out at the receiving end. This is only effective when the other machine has ECM as well. Press 2 (NO) to turn off ECM mode. (When there is considerable noise on the line, you may find that ECM slows transmission. Turning off ECM mode may increase transmission speed.) Initial setting: YES</p>

Option Settings

DIAL TONE DETECTION	<p>Press 1 (YES) to have the machine verify the presence of a dial tone on the line before automatic dialling. Press 2 (NO) to turn this function off.</p> <p>Note: If you select YES and find that the machine is unable to dial, change the setting to NO.</p> <p>Initial setting: NO</p>
KEY TONE	<p>Press 1 (ON) to have the machine sound a beep each time a key is pressed on the operation panel (this confirms that the key has been correctly pressed). Press 2 (OFF) to turn off the beep sound.</p> <p>Initial setting: ON</p>

Print Settings

Make a selection for the displayed setting as explained below.
This is done in step 3 of the procedure on page 49.



Setting	Description
RECEIVE RATIO	<p>Press 1 (AUTO) to have the machine automatically reduce the size of received faxes to fit the size of the printing paper. This ensures that the edges of a fax are not cut off. (Note: AUTO may not operate if the received fax is too long, contains many fine graphics or images, or is sent at high resolution. In this case, the remainder of the fax will be printed on a second page.) Press 2 (100%) to have all faxes printed at full size (if a fax is too long to fit on the paper, the remainder will be printed on a second sheet; note that the cut-off point may occur in the middle of a line). Initial setting: AUTO</p>
SORT COPY	<p>This setting determines whether or not copies are collated (sorted into sets) when multiple copies of each original page are made.</p> <p>Press 1 (YES) to have copies automatically sorted, or 2 (NO) to have copies grouped by page. Initial setting: NO</p>
INK SAVE MODE	<p>To use less ink and speed up ink drying time when printing faxes and copies, press 1 (ON) to turn on Ink Save Mode. If you prefer a higher quality image, press 2 (OFF) to turn off Ink Save Mode. Initial setting: OFF</p>
QUALITY MODE	<p>To have the machine print higher quality images by printing slowly when the resolution is set to HALF TONE, press 1 (YES) to turn on Quality Mode. If you prefer faster printing at the expense of slightly reduced image quality when using HALF TONE, press 2 (NO) to turn off Quality Mode. (Note: This setting does not affect the amount of ink used.) Initial setting: YES</p>

Print Settings



ALIGN CARTRIDGE	This is used to align the print cartridge to improve print quality. See page 58.
CLEAN NOZZLES	This is used to clean the print cartridge nozzles if print quality is not satisfactory after aligning the print cartridge. See page 58.

8. Printing Lists

You can print lists showing settings and information entered in the machine.

1 Press  , then  until [LISTING MODE] appears.

2 Press .

3 Press  or  until the desired list (see below) appears.

- **ACTIVITY LIST:** This report shows information on your most recent transmissions and receptions (combined maximum of 30). The headings are the same as in the Transaction Report (see the next section). The logged transactions are erased after the report is printed. To have the report print automatically whenever the number of logged transactions reaches 30, see page 49 and “AUTO PRINT OUT” on page 51.
- **DESTINATION LIST:** This shows the fax and e-mail destinations that have been stored in Rapid Key and Speed Dial numbers (pp. 20 and 29).

- **GROUP LIST:** This shows the destinations that are stored in the Group Keys (p. 40).
- **SETUP LIST:** This shows your currently entered sender's name, sender's number, and anti-junk fax number, your current selections for the option settings, print setup, and receive faxes to e-mail, and a sample of the header printed at the top of every fax page you transmit (**HEADER PRINT**).
- **CALLER-ID LIST:** This shows information on your 30 most recently received calls and faxes (p. 42). (This list is only available if you are using the Caller ID function.)
- **RECEIVE FAX TO E-MAIL LIST:** This shows the Receive Fax to E-mail settings that have been stored (page 44).
- **NETWORK SETTING LIST:** This shows the machine's current IP address and other network/Internet settings (page 25).

4 Press  to print the list.

Help List

This list provides a brief guide to the operation of the machine. Press

COPY/HELP



whilst no document is loaded in the feeder to print this list.

Transaction Report

Transaction Report

This report is printed out automatically after a fax is sent or received to allow you to check the result. The machine is initially set to print out the report only when an error occurs.

- ◆ The Transaction Report cannot be printed manually. To change the condition for automatically printing out Transaction Reports, see page 49 and "TRANSACTION LIST" on page 50.

Headings in the Transaction Report

SENDER/RECEIVER	The name or fax number of the other machine.
START	Starting time.
TX/RX TIME	Total time taken for transmission/reception.
PAGES	Number of pages.

NOTE

One of the following notes will appear under **NOTE** to indicate whether the fax was successful, and if not, why it failed.

OK - Transmission/reception was successful.

P.FAIL - A power failure prevented the transaction.

JAM - The printing paper or document jammed.

BUSY - The fax was not sent because the line was busy.

COM.E-X - (Where "X" is a number.) A communication error occurred. See page 61.

CANCEL - The fax was

canceled because the  was pressed, no document was in the feeder, or the other machine requested a function that your machine does not have.

9. Maintenance

Cleaning the Machine

Cleaning the scanning glass and rollers

Any dirt on the scanning glass and rollers will degrade the quality of transmitted documents and copies. Clean these frequently as explained below.

- ◆ If the document does not feed or double-feeds occur, use a cloth moistened with water to wipe the rollers.

- 1** Open the cover.

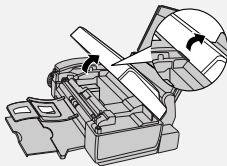

- 2** Rotate the lever so that it points straight up (1) and pull it up (2).

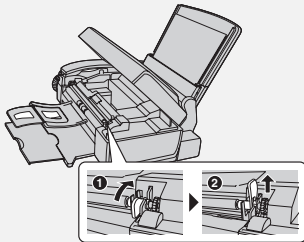

- 3** Pull the white roller out to the right. Wipe the scanning glass, rollers, and rubber sheet with a clean cloth or swab.

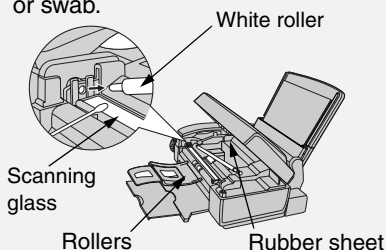

- Do not wipe off the grease on the ends of the white roller.
 - Make sure that all dirt and stains (such as correcting fluid) are removed. Dirt and stains will cause vertical lines on transmitted images and copies.
 - If the scanning glass is difficult to clean, try moistening the cloth with isopropyl alcohol or denatured alcohol. Take care that no alcohol gets on the rollers.
 - Do not press down on the two front rollers.
 - Use a cloth moistened with alcohol to wipe off any splattered ink on the inside of the compartment or the underside of the cover. (Do not wipe the rollers or rubber sheet with the alcohol-moistened cloth.)
- 4** Replace the white roller, inserting the left end first. Push the lever down and rotate it back down.

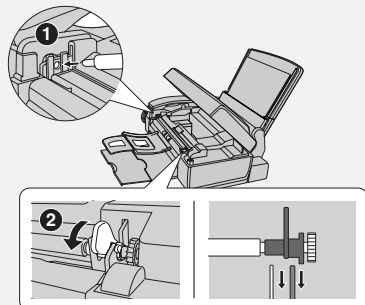

Improving Print Quality

- 5 Close the cover, pressing down firmly to make sure it clicks into place.

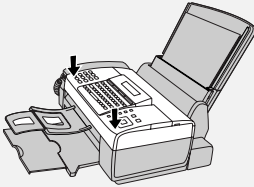

Cleaning the housing

Wipe the external parts and surface of the machine with a dry cloth.







Caution: Do not use benzene or thinner. These solvents may damage or discolor the machine.

Improving Print Quality

Aligning the print cartridge

If print quality is not satisfactory, first try aligning the print cartridge.

Note: Make sure that paper is loaded before beginning this procedure.

- 1 Press , then  until **[PRINT SET-UP]** appears.
- 2 Press , then  until **[ALIGN CARTRIDGE]** appears.
- 3 Press  to print an alignment page. (To enter an alignment value without printing a page, press .)

- 4 In the page that the machine prints, locate the line that is closest to a completely straight line.

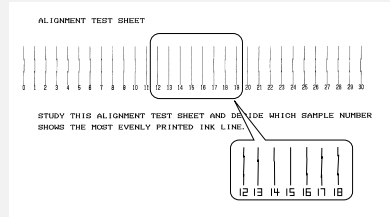

In this example, "15" is closest to a straight line.

- 5 Enter the number of the straightest line with the number keys.





- To clear a mistake, press .

- 6 Press . **[CLEAN NOZZLES]**

- 7 Press  to exit.

Cleaning the print cartridge nozzles

If print quality is still not satisfactory after aligning the print cartridge, clean the print cartridge nozzles.

- 1 Press , then  until **[PRINT SET-UP]** appears.
 - 2 Press , then  until **[CLEAN NOZZLES]** appears.
 - 3 Press .
- The machine prints a test pattern similar to the one shown in the following step.

4 Compare the diagonal lines above the printed bars to the diagonal lines below the printed bars.

- Look for breaks in the diagonal lines above the bars. Breaks indicate clogged nozzles.

Breaks in the diagonal lines at the top of the page indicate clogged nozzles.

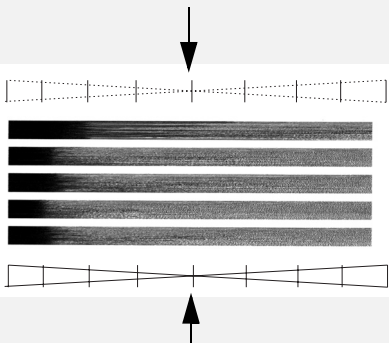

Unbroken lines at the bottom of the page indicate the nozzles were cleaned.

- 5** If the bottom diagonal lines still have breaks, repeat Steps 1 through 4 to clean the nozzles again. Repeat several more times if necessary. If the print quality is still not satisfactory after cleaning the nozzles several times, continue with Step 6.
- 6** Open the cover and remove and then reinstall the print cartridge (see the procedure beginning on page 10).
- 7** Repeat the nozzle cleaning procedure. If the lines are still broken, wipe the nozzles as explained in the following section.

Wiping the print nozzles and contacts

If you have cleaned the print nozzles as explained in the previous section at least three times and print quality is still not satisfactory, try wiping the print nozzles and contacts.

1 Open the cover and remove the print cartridge (see the procedure beginning on page 10).

- **CAUTION! DO NOT** touch the gold contact area of the cartridge or the contact area of the cartridge holder with your fingers.

2 Place two or three sheets of paper on a table or other flat surface. Moisten a clean, lint-free cloth with warm water and place the cloth on the paper.

3 Gently press the nozzles against the cloth for about three seconds, and then move the cartridge slowly in the direction shown to wipe the nozzles.

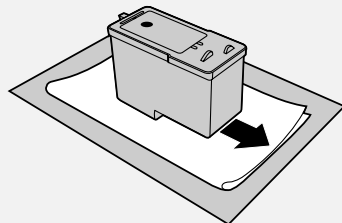

4 Using another clean section of the cloth, repeat the above step.

Improving Print Quality

- 5** Moisten another clean cloth with warm water. Gently hold the cloth against the contacts for about 3 seconds, and then wipe in the direction shown.

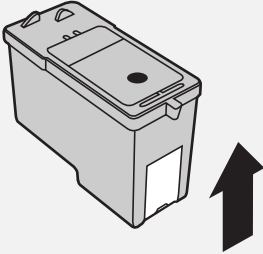

- 6** Using another clean section of the cloth, repeat the above step.
- 7** Allow the nozzles and contacts to dry completely.
- 8** Reinstall the print cartridge and repeat the nozzle cleaning procedure as explained in the previous section.
- If print quality is still not satisfactory after the nozzles are cleaned, replace the print cartridge (see page 10).

Cleaning the cartridge holder

A dirty print cartridge holder may cause smudges on your printed pages. To clean the print cartridge holder, open the cover and remove the print cartridge (see the procedure beginning on page 10). Wipe the part indicated below with a damp cloth.

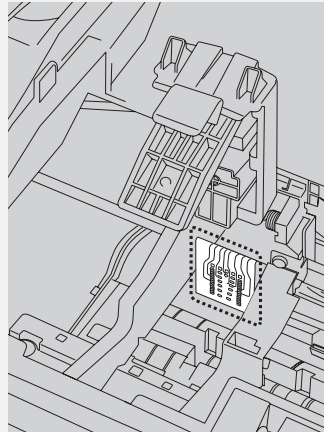

About the lithium battery:

The machine uses a lithium battery to retain settings and information programmed in the machine when the power is turned off. Battery power is consumed primarily when the power is off. With the power kept continuously off, the life of the battery is about 5 years. If the battery dies, have your dealer or retailer replace it. Do not try to replace it yourself.

10. Troubleshooting

Problems and Solutions

◆ For network connection problems (Scan to E-mail), see page 17.

Line error

Problem	Solution
LINE ERROR appears in the display.	<p>A line error occurs when your machine cannot communicate correctly with another fax machine. The error is usually due to a problem on the phone line. Try faxing again. If unsuccessful, check the following:</p> <ul style="list-style-type: none">• Check the connection. The cord from the TEL. LINE socket to the wall socket should be no longer than two meters.• Make sure there are no modem devices sharing the same telephone line.• Check with the other party to make sure their fax machine is functioning properly.• Have your telephone line checked for line noise.• Try connecting the machine to a different phone line.• If the error persists, the machine may need service.

Dialling and transmission problems

Problem	Solution
No dial tone when you pick up the handset or press  .	<ul style="list-style-type: none">• Make sure the handset cord is connected to the correct socket. See <i>Connect the handset</i> on page 8.• Make sure that the telephone line is properly connected to both the TEL. LINE socket and the wall socket (see page 12).• Make sure that the telephone line is good.

Problems and Solutions

<p>Dialling is not possible.</p>	<ul style="list-style-type: none"> • Make sure the power cord is properly plugged into a power outlet. • Make sure that the telephone line is properly connected to both the TEL. LINE socket and the wall socket (see page 12).
<p>The power is on, but no transmission takes place.</p>	<ul style="list-style-type: none"> • Make sure that the receiving machine has paper. • If the receiving machine is in manual mode with no attendant, reception will not be possible. • Check the display for error messages. • Pick up the handset and check for a dial tone. Dial the receiving machine manually and make sure that it is responding (you should hear a fax tone).
<p>Fax and e-mail transmission are not possible.</p>	<ul style="list-style-type: none"> • If 100 pages or more are stored in memory (the display shows 40% or higher memory use when  is pressed), fax and e-mail transmission may not be possible. If the message reads 40% or more memory use, you can fix the problem by printing all the faxes held in memory (see page 37).
<p>Nothing is printed at the receiving end.</p>	<ul style="list-style-type: none"> • Make sure that the document for transmission is placed face down in the feeder.
<p>A distorted image is received at the other end.</p>	<ul style="list-style-type: none"> • Noise on the telephone line may cause distortion. Try sending the document again. • Make a copy of the document on your machine. If the copy is also distorted, your machine may need service.

Reception and copying problems

Problem	Solution
<p>The machine doesn't receive documents automatically.</p>	<ul style="list-style-type: none"> • Make sure that the reception mode is set to AUTO.

The printing paper comes out blank when you try to receive a document.	<ul style="list-style-type: none"> • Make sure that the document is loaded properly in the feeder of the transmitting machine. Make a copy or print a report to confirm the printing ability of your machine.
Print quality is poor.	<ul style="list-style-type: none"> • The print cartridge may need alignment or cleaning. See page 58.
The received document is faint.	<ul style="list-style-type: none"> • Ask the other party to send higher contrast documents. • The print cartridge may need replacement. Make a copy or print a report to check your machine's printing ability.
Received images are distorted.	<ul style="list-style-type: none"> • Noise on the telephone line may cause distortion. Have the other party try sending the document again. • Make a copy or print a report on your machine. If the copy or report is also distorted, your machine may need service.
The quality of copies is poor and/or dark vertical lines appear.	<ul style="list-style-type: none"> • Any dirt or material on the scanning glass will cause spots to appear on copies and transmitted faxes. Clean the scanning glass as explained on page 57.

General problems



Problem	Solution
Nothing appears in the display.	<ul style="list-style-type: none"> • Make sure the power cord is properly plugged into a power outlet. • Connect another electrical appliance to the outlet to see if it has power.
The machine does not respond when you press any of its keys.	<ul style="list-style-type: none"> • If a beep sound is not made when you press the keys, unplug the power cord and then plug it in again several seconds later.
Automatic document feeding does not work for transmission or copying.	<ul style="list-style-type: none"> • Check the size and weight of the document (see <i>Transmittable Documents</i> on page 26).

Messages and Signals

Messages and Signals

Display messages

Note: If you have turned on the Caller ID function, see page 42 for display messages related to Caller ID.

ADD PAPER & / PRESS START KEY (alternating messages)	Check the printing paper. If the tray is empty, add paper and then press  . If there is paper in the tray, make sure it is inserted correctly (take out the stack, align the edges evenly, and then reinsert it in the tray) and then press  .
CHANGE CARTRIDGE	This message appears after you install or replace the print cartridge (see page 11).
CHECK CARTRIDGE	The print cartridge is missing and must be installed, or is not installed correctly.
CONNECTION ERROR	A Scan to E-mail transmission was not successful because of a communication problem on your local network. This is usually due to a problem with the cable connections. Make sure that the cable ends are securely inserted in the LAN ports. Make sure that the correct cable is being used and that the cable is good. Make sure that your router or hub is powered on.
CHECK E-MAIL SETTING	Scan to E-mail transmission is not possible because the SMTP server or the sender address has not been specified in the e-mail settings (see page 17).
DOCUMENT JAMMED	The original document is jammed. See the following section, <i>Clearing Paper Jams</i> . Document jams will occur if you load more than 20 pages at once or load documents that are too thick (see page 26). The document may also jam if the receiving machine doesn't respond properly when you attempt to send a fax.
FAX RX IN MEMORY	A fax has been received in memory because the print cartridge needs replacement, you have run out of printing paper, or the paper is jammed. The fax will print out automatically when the problem is fixed.

INK NEAR EMPTY	The cartridge is nearly empty (approximately one eighth of the ink remains).
LINE ERROR	Transmission or reception was not successful. Press  to clear the message and then try again. If the error persists, see <i>Line error</i> on page 61.
LOW INK	The cartridge is low on ink (approximately one quarter of the ink remains).
MEMORY FULL	If faxes have been received to memory because printing is not possible, resolve the problem so that printing can continue (see <i>Reception to Memory</i> on page 37). If faxes are being held in memory because the Secure Receive function has been activated, print the faxes as explained on page 46. If you are attempting to broadcast or transmit from memory, see <i>If the memory becomes full</i> on page 40. If you are copying, see <i>If MEMORY FULL appears</i> on page 38.
OUT OF INK	The cartridge is out of ink and must be replaced. Faxes will be received to memory.
PAPER JAMMED	The printing paper is jammed. See page 67.
PRINTER ERROR	A printer error has occurred. Open the cover, make sure the print cartridge is installed correctly, and then close the cover.
PRINTER ERROR/ CHECK PAPER	A paper jam may have occurred. Follow the procedure on page 67 to clear the jam.
RECALLING	This appears if you attempt to send a fax by auto dialling and the line is busy or the receiving fax machine does not answer. Your machine will automatically reattempt the call. (See <i>Automatic redialling</i> on page 33.)
RECEIVED SECURE FAX	A received fax is being held in memory because the Secure Receive function has been activated. Enter your secure code to print the fax (see page 46).

Messages and Signals

SERVER ERROR	A Scan to E-mail transmission was not successful because the machine could not connect to your mail server or there was no response from the mail server. Make sure the SMTP server setting is correct (p. 19). If you have configured "SMTP Authentication" settings or "POP before SMTP" settings in the machine's Web pages, make sure these settings are correct (p. 17). If [CABLE DISCONNECTED] appears on the bottom line, see "CONNECTION ERROR" on page 64.
SERVER ERROR/ SMTP-AUTH	A Scan to E-mail transmission was not successful because your SMTP server requires SMTP authentication and the SMTP authentication user name or password entered in the machine's Web page is not correct (p. 17).
SERVER NOT FOUND/ CABLE DISCONNECTED	See "CONNECTION ERROR" on page 64.
SERVER NOT FOUND/ DHCP	A Scan to E-mail transmission was not successful because the machine was unable to automatically obtain an IP address. Restart your router or other device that acts as your DHCP server.
SERVER NOT FOUND/ SMTP	A Scan to E-mail transmission was not successful because an incorrect host name is entered for your SMTP server. Check the SMTP server setting (p. 19).

Audible signals

Continuous tone	3 seconds	Indicates the end of transmission, reception, or copying.
Intermittent tone (3 beeps)	5 seconds (1 second on, 1 second off)	Indicates incomplete transmission, reception, or copying.

Clearing Paper Jams

Clearing a jammed document

If the original document doesn't feed properly during transmission or copying, or [DOCUMENT JAMMED] appears in

the display, first try pressing . If the document doesn't feed out, remove it as explained below.

Important: Do not try to remove a jammed document without releasing it as explained below. This may damage the feeder mechanism.

- 1 Open the cover (1). Rotate the lever so that it points straight up (2), and pull it up (3). Pull the roller out to the right, and remove the document (4).

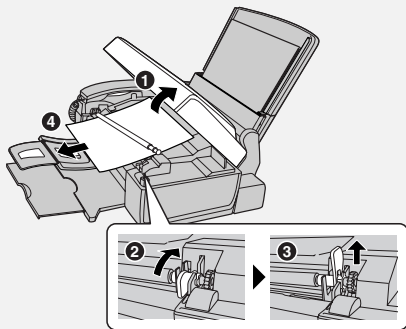

- 2 Replace the white roller, inserting the left end first. Push the lever down and rotate it back down (1). Close the cover, pressing firmly on both front corners (2).

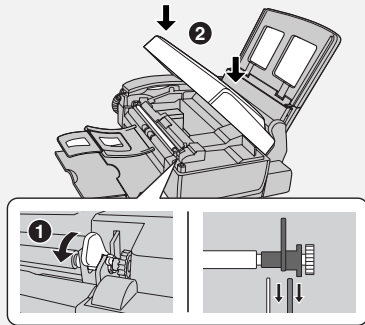

Clearing jammed printing paper

- 1 Open the cover (1). Pull the jammed paper forward or backward out of the machine as appropriate (2), taking care not to tear it.

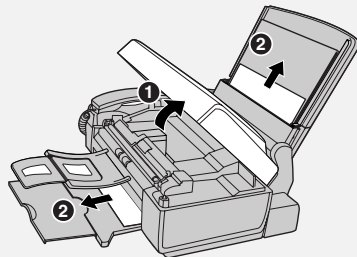

- 2 Close the cover, pressing down firmly on both front corners.

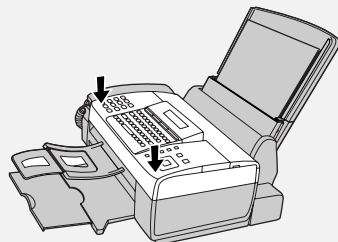

Quick Reference Guide

Fax / Scan to E-mail Transmission

Place your document (up to 20 pages) face down in the document feeder.

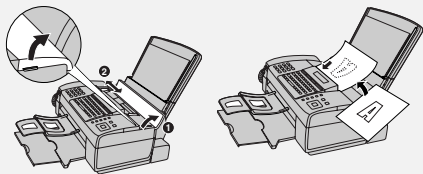

Sending a Fax by Normal Dialling



- 1 Lift the handset or press  .
- 2 Dial the fax number.
- 3 Wait for the reception tone (if a person answers, ask them to press their Start key).

- 4 Press  .



Using a Rapid Key (fax/e-mail)

Press the Rapid Key for the destination.

Using a Speed Dial number (fax/e-mail)

- 1 Press  .
- 2 Enter the appropriate 2-digit Speed Dial number and press  .

Searching for a destination (fax/e-mail)

- 1 Press  or  until the desired destination appears.
- 2 Press  .

Receiving Faxes

Press  until the desired reception mode appears in the display.









AUTO mode: The machine automatically answers and receives faxes.

MANUAL mode: Answer all calls (even faxes) by picking up the handset. To

begin fax reception, press  .

TEL/FAX mode: The machine automatically answers and receives faxes. Voice calls are signalled by a special ringing sound.

Storing Destinations

- 1 Press , , then  .
- 2 Press an unused Rapid Key, or press  and enter an unused 2-digit Speed Dial number (01 to 63). (For an e-mail destination, you can also press the **A**, **B** or **C** key and go to Step 4.)
- 3 Press  for fax or  for e-mail.
- 4 Enter the fax number or the e-mail address.
- 5 Press  .
- 6 Enter a name with the letter keys.
- 7 Press  and then  .

Index

A

Anti Junk Fax, 43
Audible signals, 66
Auto Print Out (of Activity Report), 51
AUTO reception mode, 14, 35
Auto-dial numbers
 Storing, 29
 Using, 31

B

Batch page numbering, 34
Broadcasting, 39

C

Caller ID, 41
Caller ID list, 42, 55
Contrast, 27
Copies, 38

D

Date, setting, 13
Destination List, 55
Dial tone detection, 52
Dialling
 Automatic redialling, 33
 Direct Keypad, 32
 Normal, 28
 Rapid Key, 31
 Redialling, 33
 Search, 32
 Speed, 32
Direct Keypad Dialling, 32
Display messages, 42, 64
Document feeder, 26
Document restrictions, 26
Document sizes, 26
Duplex Scan, 43

E

ECM mode (Error Correction Mode), 51
E-mail addresses, storing, 20

E-mail message, 19, 23
E-mail options, 23
E-mail settings, 17, 19
E-mail subject, 19, 23
Extension telephone
 Connecting, 12
 Using, 36

F

Fax Remote Number, 49
Fax Signal Receive, 51
File format, 19, 23
File name, 23
Fine Priority setting, 49
Flash Select setting, 50

G

Group Keys, storing, 40
Group keys, using, 40
Group List, 55

H

Halftone setting, 27
Handset, 8
Housing, cleaning, 58

I

Ink Save Mode, 53
IP address, 16, 25

J

Jams, clearing, 67

K

Key Tone setting, 52

L

Letters, entering, 6
Line error, 61
Loading paper, 9
Loading the document, 26

Index

M

MANUAL reception mode, 14, 36
Memory full, 65
Memory, substitute reception to, 37

N

Network
 Cable, 15
 Checking connection, 16
 Connecting to, 15
 Problems, 17
Network Setting List, 55
Network settings, configuring, 25
Network settings, initializing, 25
Normal Dialling, 28
Number of Rings setting, 49

P

Packing tape, removing, 8
Page numbering, batch, 34
Paper jams, clearing, 67
Paper, loading, 9
Power cord, 10
Print cartridge
 Aligning, 58
 Cleaning nozzles, 58
 Installing, 10
 Wiping nozzles, 59
Print cartridge holder, wiping, 60
Pseudo Ring, 50

Q

Quality Mode setting, 53

R

Rapid Key Dialling, 31
Rapid Key, using for e-mail, 22
Receive Fax to E-mail, 44
Receive Fax to E-mail List, 55
Receive Ratio setting, 53
Reception mode

AUTO, 14, 35
MANUAL, 14, 36
TEL/FAX, 14, 35

Redialling, 33
Redialling, automatic, 33
Removing original document, 27
Resolution, 27
Ringer volume, 14

S

Scan to E-mail transmission, 22
Scanning glass, cleaning, 57
Search Dialling, 32
Searching for stored e-mail address, 22
Secure Receive, 46
Sender address, 19
Sender name, 19
Sender's name and fax number,
 entering, 13
Setup List, 55
SMTP server, 19
Sort Copy, 53
Speaker volume, 14
Speed Dial number, using for e-mail, 22
Speed Dialling, 32

T

TEL. LINE socket, 12
TEL. SET socket, 12
TEL/FAX reception mode, 14, 35
Telephone line cord, 12
Time, setting, 13
Transaction Report, 56
 Setting print condition, 50

V

Voice calls, 32

W

Web page in machine, 18

A. Information on Disposal for Users (private households)

1. In the European Union

Attention: If you want to dispose of this equipment, please do not use the ordinary dust bin!

Used electrical and electronic equipment must be treated separately and in accordance with legislation that requires proper treatment, recovery and recycling of used electrical and electronic equipment.

Following the implementation by member states, private households within the EU states may return their used electrical and electronic equipment to designated collection facilities free of charge*. In some countries* your local retailer may also take back your old product free of charge if you purchase a similar new one.

*) Please contact your local authority for further details.

If your used electrical or electronic equipment has batteries or accumulators, please dispose of these separately beforehand according to local requirements.

By disposing of this product correctly you will help ensure that the waste undergoes the necessary treatment, recovery and recycling and thus prevent potential negative effects on the environment and human health which could otherwise arise due to inappropriate waste handling.

2. In other Countries outside the EU

If you wish to discard this product, please contact your local authorities and ask for the correct method of disposal.

For Switzerland: Used electrical or electronic equipment can be returned free of charge to the dealer, even if you don't purchase a new product. Further collection facilities are listed on the homepage of www.swico.ch or www.sens.ch.

B. Information on Disposal for Business Users.

1. In the European Union

If the product is used for business purposes and you want to discard it:

Please contact your SHARP dealer who will inform you about the take-back of the product. You might be charged for the costs arising from take-back and recycling. Small products (and small amounts) might be taken back by your local collection facilities.

For Spain: Please contact the established collection system or your local authority for take back of your used products.

2. In other Countries outside the EU

If you wish to discard of this product, please contact your local authorities and ask for the correct method of disposal.



Attention: Your product is marked with this symbol. It means that used electrical and electronic products should not be mixed with general household waste. There is a separate collection system for these products.

SHARP®

SHARP ELECTRONICS (U.K.) LTD.

4 Furzeground Way, Stockley Park, Uxbridge, Middlesex UB11 1EZ

SHARP CORPORATION

PRINTED IN THAILAND
(TINSE4533XHTZ)

Free Manuals Download Website

<http://myh66.com>

<http://usermanuals.us>

<http://www.somanuals.com>

<http://www.4manuals.cc>

<http://www.manual-lib.com>

<http://www.404manual.com>

<http://www.luxmanual.com>

<http://aubethermostatmanual.com>

Golf course search by state

<http://golfingnear.com>

Email search by domain

<http://emailbydomain.com>

Auto manuals search

<http://auto.somanuals.com>

TV manuals search

<http://tv.somanuals.com>