



1813 VoIP Gateway

User's Guide

Document Number 1813-A2-GB20-00

November 2004

PARADYNE[®]

Copyright © 2004 Paradyne Corporation.

All rights reserved.

Printed in U.S.A.

Notice

This publication is protected by federal copyright law. No part of this publication may be copied or distributed, transmitted, transcribed, stored in a retrieval system, or translated into any human or computer language in any form or by any means, electronic, mechanical, magnetic, manual or otherwise, or disclosed to third parties without the express written permission of Paradyne Corporation, 8545 126th Ave. N., Largo, FL 33773.

Paradyne Corporation makes no representation or warranties with respect to the contents hereof and specifically disclaims any implied warranties of merchantability or fitness for a particular purpose. Further, Paradyne Corporation reserves the right to revise this publication and to make changes from time to time in the contents hereof without obligation of Paradyne Corporation to notify any person of such revision or changes.

Changes and enhancements to the product and to the information herein will be documented and issued as a new release to this manual.

Warranty, Sales, Service, and Training Information

Contact your local sales representative, service representative, or distributor directly for any help needed. For additional information concerning warranty, sales, service, repair, installation, documentation, training, distributor locations, or Paradyne worldwide office locations, use one of the following methods:

Internet: Visit the Paradyne World Wide Web site at www.paradyne.com. (Be sure to register your warranty at www.paradyne.com/warranty.)

Telephone: Call our automated system to receive current information by fax or to speak with a company representative.

Within the U.S.A., call 1-800-870-2221

Outside the U.S.A., call 1-727-530-2340

Document Feedback

We welcome your comments and suggestions about this document. Please mail them to Technical Publications, Paradyne Corporation, 8545 126th Ave. N., Largo, FL 33773, or send e-mail to userdoc@paradyne.com. Include the number and title of this document in your correspondence. Please include your name and phone number if you are willing to provide additional clarification.

Trademarks

Acculink, Bitstorm, Comsphere, DSL the Easy Way, ETC, Etherloop, FrameSaver, GrandSLAM, GrandVIEW, Hotwire, the Hotwire logo, Jetstream, MVL, NextEDGE, Net to Net Technologies, OpenLane, Paradyne, the Paradyne logo, Paradyne Credit Corp., the Paradyne Credit Corp. logo, Performance Wizard, StormPort, TruePut are registered trademarks of Paradyne Corporation. ADSL/R, Connect to Success, Hotwire Connected, iMarc, JetFusion, JetVision, MicroBurst, PacketSurfer, Quick Channel, ReachDSL, Reverse Gateway, Spectrum Manager, and StormTracker are trademarks of Paradyne Corporation. All other products and services mentioned herein are the trademarks, service marks, registered trademarks, or registered service marks of their respective owners.

CE Marking

When the product is marked with the CE mark on the equipment label, a supporting Declaration of Conformity may be downloaded from the Paradyne World Wide Web site at www.paradyne.com. Select *Library* → *Technical Manuals* → [CE Declarations of Conformity](#).

Preface

This manual is written to provide information to network administrators. It covers the installation, operation and applications of the 1813 VoIP Gateway.

Important Safety Instructions

1. Read and follow all warning notices and instructions marked on the product or included in the manual.
2. Slots and openings in the cabinet are provided for ventilation. To ensure reliable operation of the product and to protect it from overheating, these slots and openings must not be blocked or covered.
3. Do not allow anything to rest on the power cord and do not locate the product where persons will walk on the power cord.
4. Do not attempt to service this product yourself, as opening or removing covers may expose you to dangerous high voltage points or other risks. Refer all servicing to qualified service personnel.
5. When installed in the final configuration, the product must comply with the applicable Safety Standards and regulatory requirements of the country in which it is installed. If necessary, consult with the appropriate regulatory agencies and inspection authorities to ensure compliance.
6. A rare phenomenon can create a voltage potential between the earth grounds of two or more buildings. If products installed in separate buildings are **interconnected**, the voltage potential may cause a hazardous condition. Consult a qualified electrical consultant to determine whether or not this phenomenon exists and, if necessary, implement corrective action prior to interconnecting the products.
7. Input power to this product must be provided by one of the following: (1) a UL Listed/CSA certified power source with a Class 2 or Limited Power Source (LPS) output for use in North America, or (2) a certified transformer, with a Safety Extra Low Voltage (SELV) output having a maximum of 240 VA available, for use in the country of installation.
8. In addition, since the equipment is to be used with telecommunications circuits, take the following precautions:
 - Never install telephone wiring during a lightning storm.
 - Never install telephone jacks in wet locations unless the jack is specifically designed for wet locations.
 - Never touch uninsulated telephone wires or terminals unless the telephone line has been disconnected at the network interface.
 - Use caution when installing or modifying telephone lines.

- Avoid using a telephone (other than a cordless type) during an electrical storm. There may be a remote risk of electric shock from lightning.
- Do not use the telephone to report a gas leak in the vicinity of the leak.

CE Marking

When the product is marked with the CE mark on the equipment label, a supporting Declaration of Conformity may be downloaded from the Paradyne World Wide Web site at **www.paradyne.com**. Select *Support -> Technical Manuals -> Declarations of Conformity*.

FCC Part 15 Declaration

An FCC Declaration of Conformity may be downloaded from the Paradyne World Wide Web site at **www.paradyne.com**. Select *Support -> Technical Manuals -> Declarations of Conformity*.

This device complies with Part 15 of the FCC Rules. Operation is subject to the following two conditions: (1) this device may not cause harmful interference, and (2) this device must accept any interference received, including interference that may cause undesired operation.

The authority to operate this equipment is conditioned by the requirement that no modifications will be made to the equipment unless the changes or modifications are expressly approved by the responsible party.

This equipment has been tested and found to comply with the limits for a Class B digital device, pursuant to Part 15 of the FCC Rules. These limits are designed to provide reasonable protection against harmful interference in a residential installation. This equipment generates, uses, and can radiate radio frequency energy and, if not installed and used in accordance with the instructions, may cause harmful interference to radio communications. However, there is no guarantee that interference will not occur in a particular installation. If this equipment does cause harmful interference to radio or television reception, which can be determined by turning the equipment off and on, the user is encouraged to try to correct the interference by one or more of the following measures:

- Reorient or relocate the receiving antenna.
- Increase the separation between the equipment and receiver.
- Connect the equipment into an outlet on a circuit different from that to which the receiver is connected.
- Consult the dealer or an experienced radio/TV technician for help.

Table of Contents

CHAPTER 1 INTRODUCTION.....	7
1.1 PRODUCT OVERVIEW	7
1.2 FEATURES.....	7
1.3 APPLICATIONS.....	8
CHAPTER 2 HARDWARE INSTALLATION.....	9
2.1 RESET BUTTON	9
2.2 WIRING INSTALLATION.....	10
2.3 FRONT PANEL LED INDICATORS	11
CHAPTER 3 LOGIN VIA THE WEB BROWSER	12
3.1 IP ADDRESS	12
3.2 VERSION	13
3.3 LOGIN PROCEDURE	14
CHAPTER 4 BASIC CONFIGURATION.....	15
4.1 ACCESS CONTROL.....	15
4.2 WAN SETUP	17
4.3 LAN IP ADDRESS	20
4.4 SAVE	22
4.5 ERASE.....	22
4.6 REBOOT	23
CHAPTER 5 SIP CONFIGURATION.....	23
5.1 INTRODUCTION	24
5.2 LOCAL.....	25
5.3 PHONELIST	27
5.4 REMOTE.....	29
5.5 CALLFORWARD.....	31
CHAPTER 6 PERFORMANCE MONITORING.....	32
6.1 SYSTEM STATISTICS	32
CHAPTER 7 SOFTWARE UPGRADE VIA FTP.....	36
APPENDIX A: SPECIFICATIONS	38
APPENDIX B: PIN ASSIGNMENTS.....	40
APPENDIX C: TROUBLESHOOTING	41
APPENDIX D: GLOSSARY.....	42

Chapter 1 Introduction

This chapter introduces the 1813 VoIP Gateway. It includes a product overview, a description of the product's features and applications, and an explanation of the front panel LED indicators.

1.1 Product Overview

Paradyne's 1813 is a powerful VoIP Gateway, providing predictable, real-time, toll-quality voice over the Internet. The 1813 VoIP Gateway is designed for residential and business users. It connects to an external Cable or DSL modem to access your broadband service.

An ordinary telephone connects to the RJ11 port (telephone jack) on the back of the 1813 VoIP Gateway, allowing calls to be routed to anywhere in the world— significantly reducing or eliminating long distance charges. Your PCs connected to the 1813 VoIP Gateway do not have to be turned on for you to make calls. The 1813 VoIP Gateway solves all of your network and telephony needs in one integrated unit, which reduces the space requirements and cost of hardware and cabling. This makes the 1813 VoIP Gateway the most cost effective solution for your application.

1.2 Features

- Supports Voice over IP (VoIP) using SIP (Session Initiation Protocol, RFC 3261)
- Uses an ordinary telephone to make Internet calls with low cost
- Use just one IP address to access the Internet over your entire network
- Supports Caller ID
- Supports silence suppression
- Configurable through your networked PC's web browser
- Remote administration and remote firmware upgrades over the Internet
- Supports PPTP, L2TP, and IpSec pass-through
- Internal 4-Port switch dramatically speeds up your gaming and multimedia connections

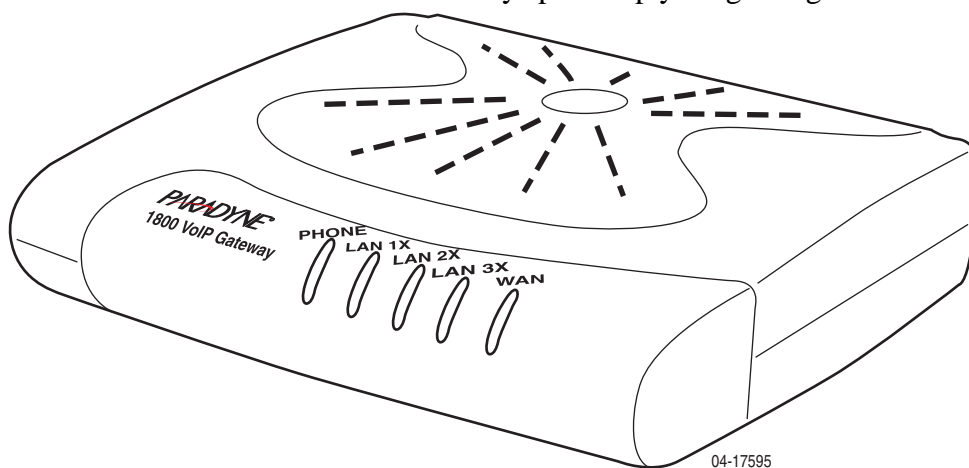

1.3 Applications

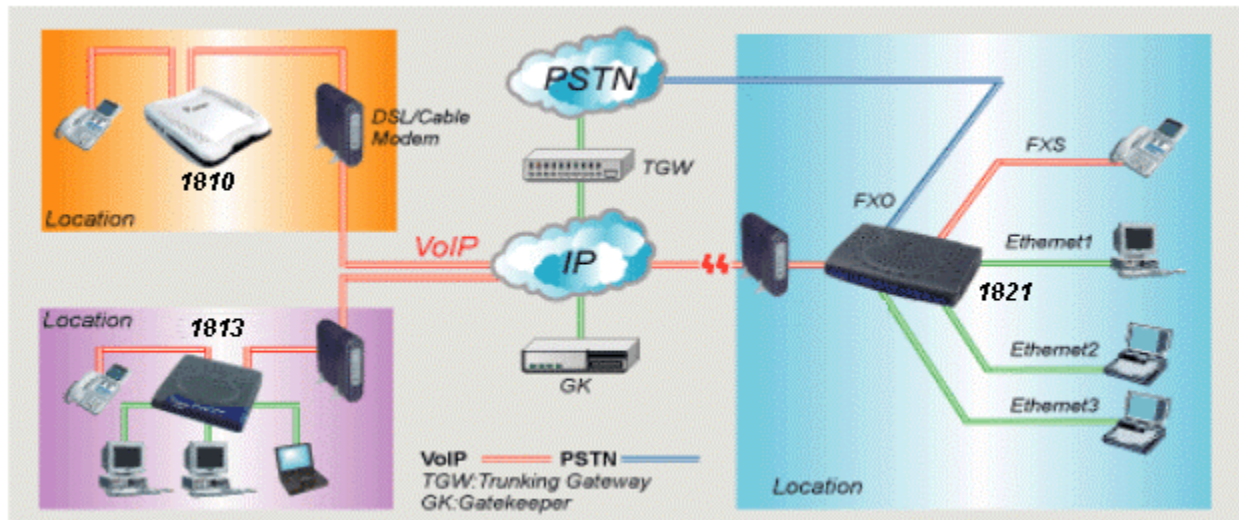

Chapter 2 Hardware Installation

2.1 Reset Button

The figure below illustrates the back panel of the Gateway. On the left side of the rear panel there is a reset button. This button is used to reload the factory default settings. Use a small object like a ballpoint pen to press the button and hold it down for over three seconds. The Gateway will be reset and all parameters will return to their factory default settings. You can verify this process by monitoring the PHONE LED. It will turn off and then on again as the Gateway restarts.

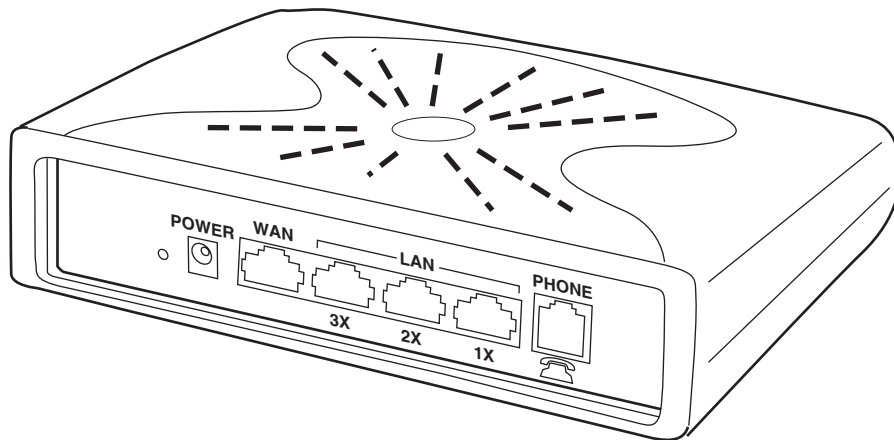

04-17596

2.2 Wiring Installation

The next figure illustrates the wiring connections for the Gateway.

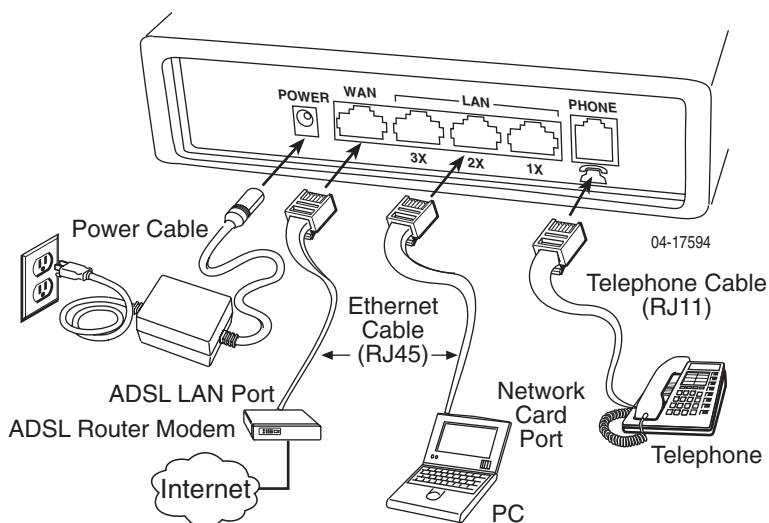

Note: If you have an installed DSL connection, disconnect the RJ45 cable from the back of your computer and connect it to the WAN port of the 1813 VoIP Gateway.

1. Connect the power adapter to the **POWER jack** of the Gateway, then plug the power adapter into an AC wall outlet.
2. Connect the **WAN port** of the Gateway to your DSL or cable modem's **LAN** port with an RJ45 connector cable.
3. Connect the **LAN ports (1X- 3X)** of the Gateway to your PC's Ethernet port, or to an Ethernet switch or hub, with an RJ45 cable. One is supplied with the Gateway.
4. Connect the **Phone port** of the Gateway to your analog telephone set with an RJ11 connector cable.

Note 1: If the device fails to power on, or it malfunctions, first verify that the power supply is correctly connected, and then power it on again.

Note 2: Restore the default parameters of the Gateway at any time by holding down the Reset button for over three seconds.

2.3 Front Panel LED Indicators

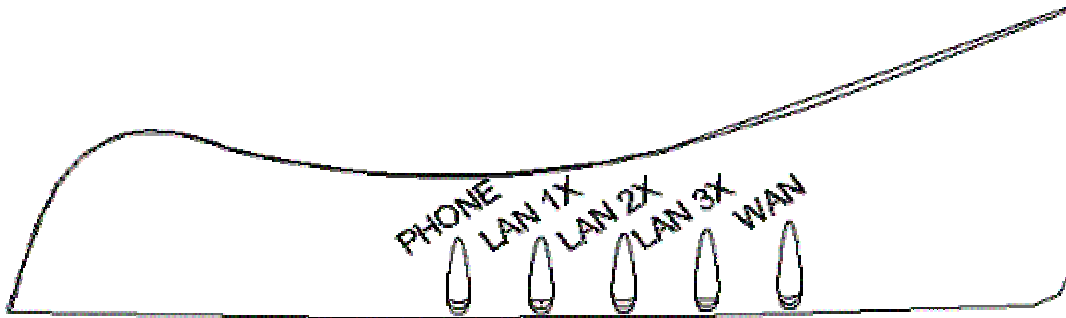

LED Indicator	Color	Mode	Function
PHONE	Red	On	Device booting
	Green	On	Registered to SIP proxy successfully
		Flash	Phone is off-hook
	Orange	On	Not registered to SIP proxy
		Flash	Phone is off-hook
LAN 1X – 3X	Green	On	An Ethernet link is established
		Off	An Ethernet link is not established
WAN	Green	On	The WAN link is established
		Off	Device booting

Note: If the device fails to power on, or it malfunctions, first verify that the power supply is correctly connected, and then power it on again.

Chapter 3 Login via the Web Browser

This section describes how to manage the VoIP gateway via a Web browser from the local or remote end. You can use a web browser such as Microsoft Internet Explorer version 6 or above, or Netscape Navigator version 6 or above. It is best to set your display resolution to 1024 x 768. To change the resolution, go to the Microsoft Windows control panel and click on the **Display** icon. You will find the display settings there.

A unique default user account is assigned with user name **root** and password **1234**. You can change the default password later.

3.1 IP Address

To log on to the device using a web browser, your workstation and the Gateway must both be on the same network segment. The default IP address for the Gateway is 192.168.1.101. You can modify the IP address of your PC by modifying its TCP/IP parameters. Follow the steps below:

STEP 1: In Windows, go to Control Panel and select Network Connections. Select your Local Area Connection (LAN) and right-click on it. Select Properties from the ensuing menu. On the General tab, scroll down to Internet Protocol (TCP/IP) and select it. Then click on the Properties button.

STEP 2: On the IP Address tab of the TCP/IP screen, change the IP address to the domain of 192.168.1.x/24.

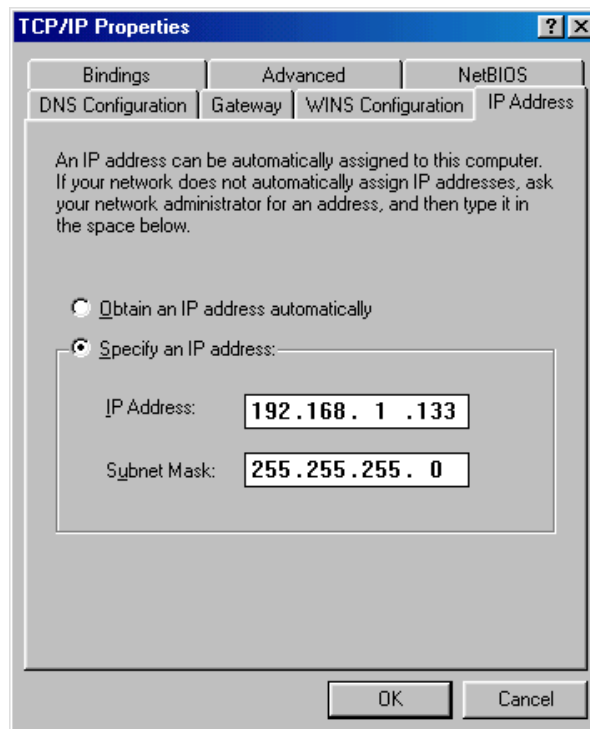

STEP 3: Click on **OK** to submit the settings. You are prompted to restart the computer. Reboot the computer as requested.

STEP 4: Start your Internet browser with the default IP address 192.168.1.101.

3.2 Version

To verify the software version of your Gateway, from the **Basic** Menu bar, click on **Version Information**. The software version is displayed.

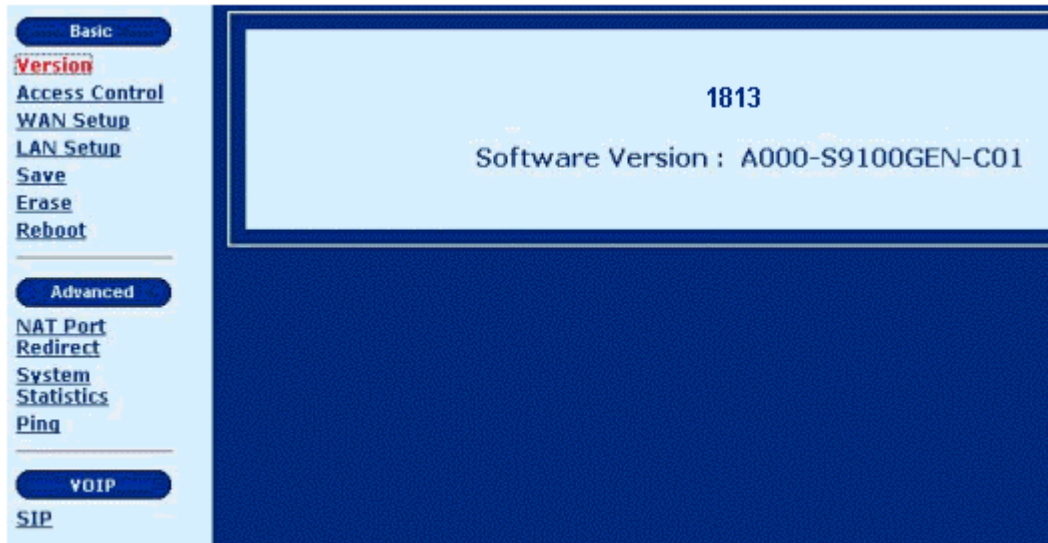

3.3 Login Procedure

To log on to the system from the web browser, follow the steps below:

- STEP 1:** Start your Internet browser.
- STEP 2:** Type the IP address for the Gateway in the Web address field. For example, if the IP address is 192.168.1.101, type **http://192.168.1.101**.
- STEP 3:** You will be prompted to enter your user name and password. Type the password. The default user Name is **root**, and the default password is **1234**. The user name and password are case-sensitive.
- STEP 4:** After successfully logging in, you will reach the main menu. On the left is a list of links, categorized into three types via: **Basic**, **Advanced**, and **VOIP**.

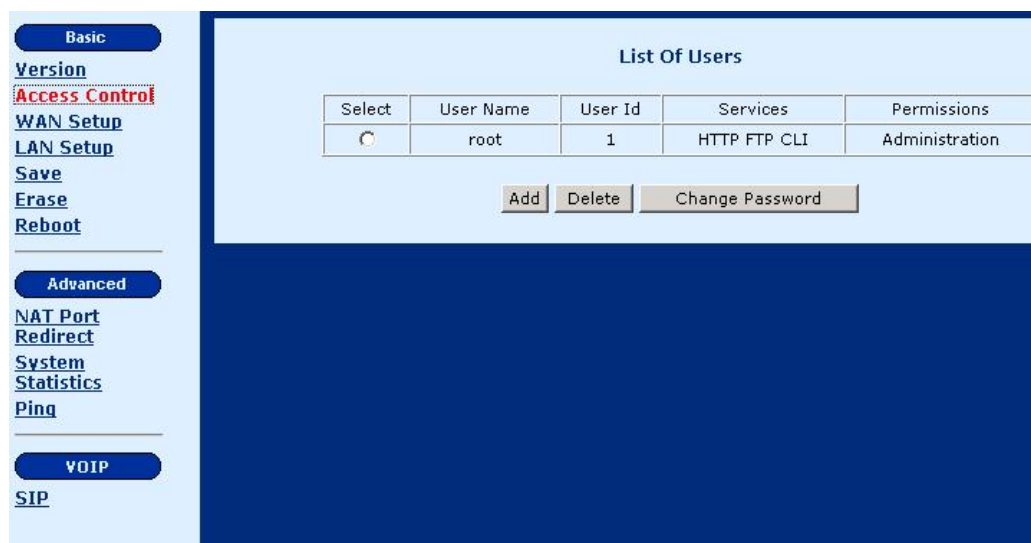

The screenshot shows a web interface with a left sidebar and a main content area. The sidebar has three sections: 'Basic' (with links: Version, Access Control, WAN Setup, LAN Setup, Save, Erase, Reboot), 'Advanced' (with links: NAT Port, Redirect, System, Statistics, Ping), and 'VOIP' (with link: SIP). The main content area is titled 'List Of Users' and contains a table with the following data:

Select	User Name	User Id	Services	Permissions
<input type="radio"/>	root	1	HTTP FTP CLI	Administration

Below the table are three buttons: 'Add', 'Delete', and 'Change Password'.

Chapter 4 Basic Configuration

From the **Basic** menu bar, you can change passwords, configure the WAN/LAN interfaces, set up routing, save settings, reboot the device, and retrieve the factory default settings.

4.1 Access Control

To manage the List of Users, click on **Access Control** on the menu bar. On the **Access Control** screen, you can **add** or **delete** users, and change their passwords.

4.1.1 Change the Password

To modify the password, click on **Access Control** on the menu bar. Select the applicable User, then click on **Change Password**.

The screenshot shows the 'List Of Users' configuration page. The left sidebar has a menu with the following items: Basic (selected), Version, Access Control (highlighted in red), WAN Setup, LAN Setup, Save, Erase, Reboot, Advanced, NAT Port Redirect, System Statistics, Ping, VOIP, and SIP. The main content area is titled 'List Of Users' and contains a table with the following data:

Select	User Name	User Id	Services	Permissions
<input type="radio"/>	root	1	HTTP FTP CLI	Administration

Below the table are three buttons: Add, Delete, and Change Password.

On the **Change Password** screen, type the old password and type the new password twice. Click on **Apply** to submit the settings.

The screenshot shows the 'Change Password' form. It has three input fields: 'Old Password:', 'New Password:', and 'Confirm New Password:'. Below the fields are 'Apply' and 'Cancel' buttons.

If you change the password, make sure you keep a record of it in a safe place, as you will require it the next time you log on.

4.1.2 Add User

To add a user entry, click on the Add button, and fill out the parameters shown below.

Click on **Apply** to submit the settings.

- **User Name:** Enter the new user name; the User Name is case-sensitive and cannot contain spaces.
- **Password:** Enter a password for the new user; the password is case-sensitive and cannot contain spaces.
- **Services:** Select authorization for **CLI**, **HTTP** or **FTP** services.
- **Permissions:** Select **Ordinary** or **Administration** user permission. Users with Administration authority (like **root**) can alter the Gateway configuration.

4.1.3 Delete User

To **delete** a User from the list of users, complete the following steps:

STEP 1: Click on **Access Control** on the menu bar.

STEP 2: Choose a User entry, and click on **Delete**.

4.2 WAN Setup

Click on **WAN Setup** from the tool bar.

The screenshot shows a light blue window titled "WAN STATUS". Inside, the text is as follows:

WAN MODE : Static IP address

Current State : Active

WAN IP Address : **0.0.0.0**
 Subnet Mask : **255.255.255.255**
 Default Gateway :

Primary DNS Server :
 Secondary DNS Server :

At the bottom center, there is a button labeled "WAN Setup".

The following are the common settings to set up these services.

Static IP address: Your Internet Service Provider (ISP) assigns you a static IP address, or the IP address of the host needs to be manually configured in your network.

DHCP mode: You obtain an IP address from your ISP automatically, via DHCP protocol.

PPPoE mode: Your ISP requires the use of PPPoE to connect to its service.

The screenshot shows a light blue window titled "WAN SETUP". On the left side, there is a vertical menu with the following items:

- Basic
- Version
- Access Control
- WAN Setup
- LAN Setup
- Save
- Erase
- Reboot
- Advanced
- NAT Port Redirect
- System Statistics
- Ping
- VOIP
- SIP

The main content area of the window is titled "WAN SETUP" and contains the following text:

Select WAN MODE :

- Static IP address
- DHCP mode
- PPPoE mode

At the bottom right, there are two buttons: "Next" and "Cancel".

4.2.1 Static IP address

Select **WAN Setup** in the Basic Menu. Then select **Static IP address** (your ISP assigns you a static IP address, or an IP address of the hosts needs manually configured in your network), and click on **Next**. The following screen is displayed.

WAN SETUP

Static IP Address :

WAN IP Address :

Subnet Mask :

Default Gateway :

Primary DNS Server :

Secondary DNS Server :

Fill in the parameters and click on **Next**.

WAN IP address	Enter the WAN IP address.
Subnet Mask	The subnet mask of the selected interface.
Default Gateway	Enter the gateway IP address of the IP network
Primary DNS Server	Enter the primary DNS server IP address.
Secondary DNS Server	Enter the secondary DNS server IP address that will be used in the event that the primary server IP address fails or is not available.

4.2.2 DHCP Mode

Select **WAN Setup** in the Basic Menu. Then select **DHCP mode** (the host obtains an IP address from the ISP automatically via DHCP protocol) and click on **Next**. The following screen is displayed. Click on Yes.

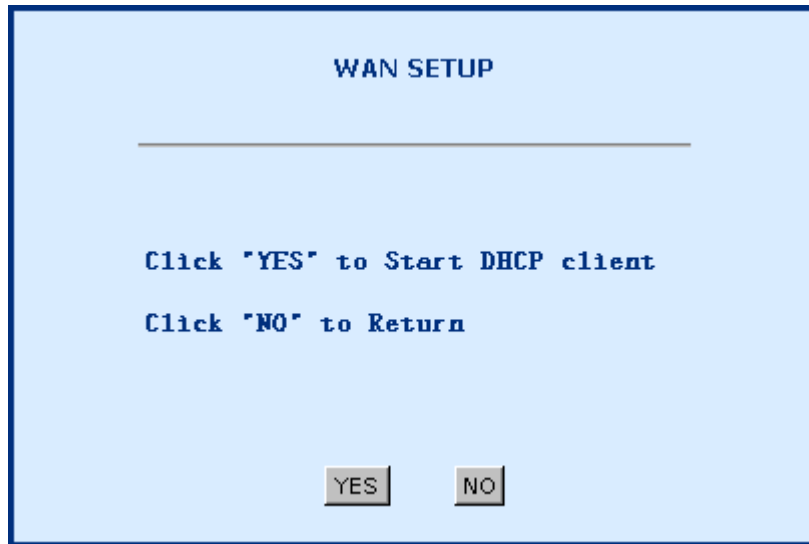

4.2.3 PPPoE

PPPoE provides session authentication using either Password Authentication Protocol (PAP) or Challenge Handshake Authentication Protocol (CHAP). Session accounting is possible and conservation of bandwidth can be achieved by closing down unused sessions. By utilizing PPP, link and network parameters are easily negotiated between the Gateway and the ISP.

When using PPPoE, the system is assigned an IP address from the Internet Service Provider as part of establishing the network connection. The system can be configured as a DHCP server for the LAN, and NAT can be used to translate private addresses to public addresses. In this way, computers in the LAN do not have to have their own public IP addresses.

To set up **PPPoE**, select **WAN Setup** in the Basic Menu.

Enter your **user name** and **password** (as assigned by your ISP) and click on **Apply**.

WAN SETUP

PPPoE Configuration

User name:

Password:

4.3 LAN IP Address

The default LAN IP address is 192.168.1.101. Click on **LAN Setup** from the menu bar to configure the LAN IP address and subnet mask. The following screen is displayed.

Basic

[Version](#)

[Access Control](#)

[WAN Setup](#)

[LAN Setup](#)

[Save](#)

[Erase](#)

[Reboot](#)

Advanced

[NAT Port Redirect](#)

[System Statistics](#)

[Ping](#)

VOIP

[SIP](#)

LAN Setup

LAN IP Address :

NetMask :

DHCP Server Configuration

Status:Enable

DHCP Server :

Starting IP Address :

End IP Address :

Lease Time (in Days) :

Enter or select the parameters as explained below. Click on **Apply** to submit the settings.

LAN IP Address	Enter the LAN IP address.
NetMask	Enter the subnet mask of the IP network.
DHCP Server	Click on Enable or Disable.
Starting IP Address	Enter the first IP address of the address pool in the DHCP server. Note that the IP address should be in the same subnet as the Gateway's LAN IP address.
End IP Address	Enter the last IP address of the address pool in the DHCP server. Note that the IP address should be in the same subnet as the Gateway's LAN IP address.

**The LAN-IP Address is going to change.
Use the new Ip Address to Browse the Web Configuration.**

**Click 'YES' to Save the Configuration and
Reboot the System now.**

Click 'NO' to change the Configuration only.

Click on **No** to change the configuration only. Click on **Yes** to save the configuration and reboot the system. The Web configuration will be interrupted. Use the new IP address to login (whether you clicked on the **Yes** or **No** button).

4.4 Save

To save the settings to Flash, click on **Save & Reboot** from the menu bar. In the main pane, click on **Save**.

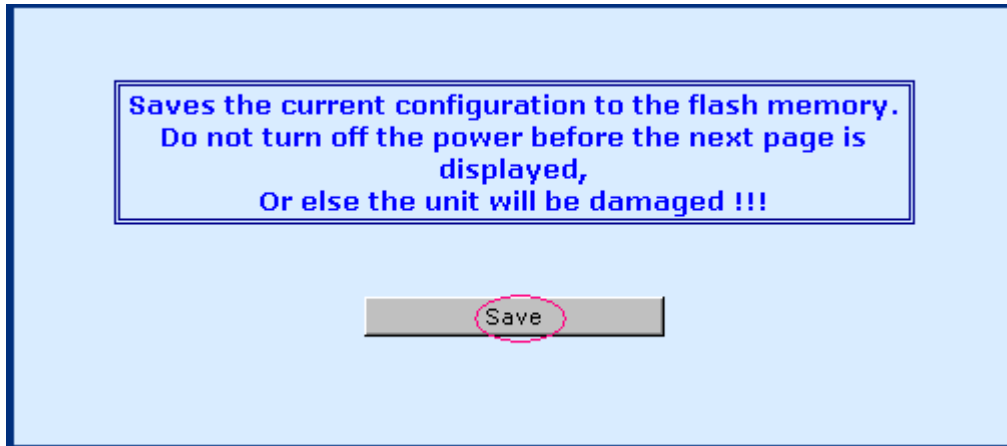

4.5 Erase

To erase the settings and reset to the original default click on **Erase** on the menu bar. In the main pane of the following display, click on **Erase**. Then, reboot the system.

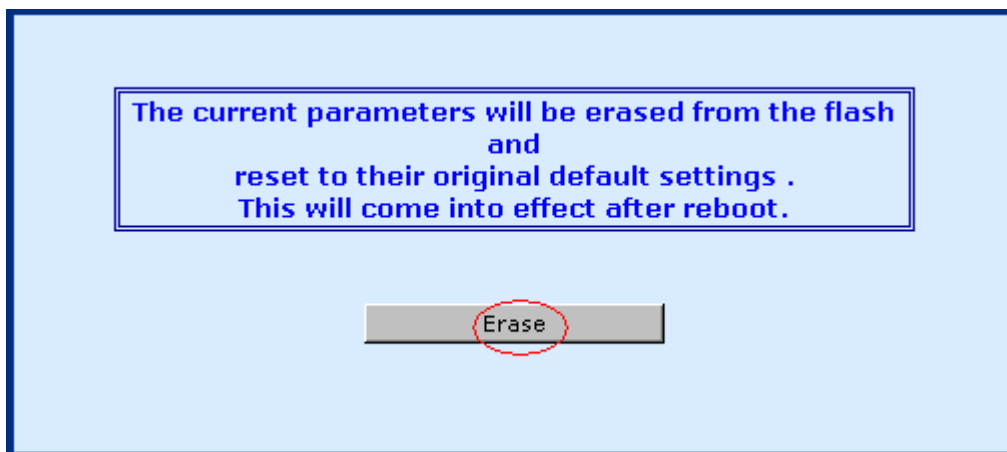

4.6 Reboot

To reboot the Gateway, click on **Reboot** from the menu bar. In the main pane, click on **Reboot**.

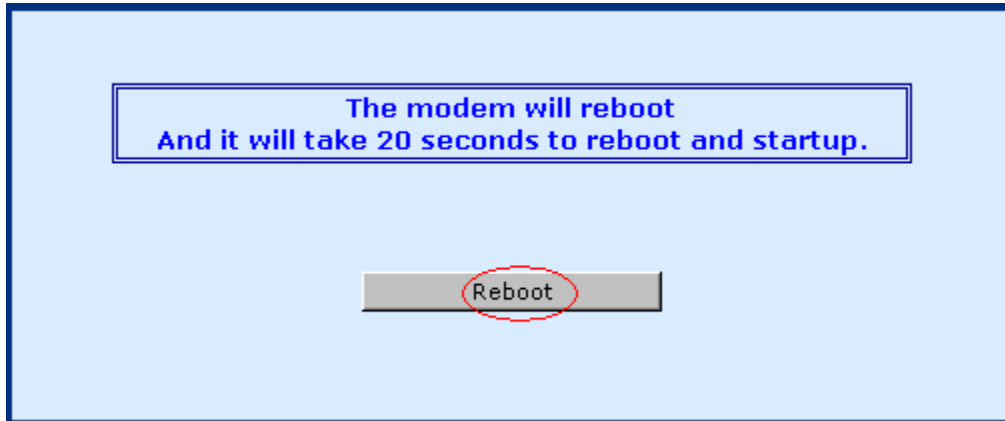

Chapter 5 SIP Configuration

SIP, the Session Initiation Protocol, is a signaling protocol for Internet conferencing, telephony, presence, events notification, and instant messaging. It is the Internet Engineering Task Force (IETF) standard for multimedia conferencing over IP, described in RFC 3261. It is designed to address the functions of signaling and session management within a packet telephony network. Signaling allows call information to be carried across network boundaries. Session management provides the ability to control the attributes of an end-to-end call.

Session Initiation Protocol is a peer-to-peer protocol. There are four components in the SIP standard:

- User Agent (UA)
- Proxy Server
- Registrar Server, and
- Redirect Server.

This section describes the SIP User Agent and the call establishment between User Agents.

5.1 Introduction

The SIP page appears when **SIP** is clicked in the in the hyperlinks menu under VoIP. This is the first and the initial screen for SIP configuration, which lists configured SIP Parameters.

The screenshot shows the 'SIP Configuration List' page. The left sidebar contains navigation menus for 'Basic', 'Advanced', and 'VOIP'. The 'SIP' link is highlighted. The main area has tabs for 'Local', 'PhoneList', 'Remote', and 'CallForward'. The 'Local' tab is selected, displaying the configuration form. The form includes sections for Host Info, Proxy / Registrar Info, Domain Info, and CODECs Info, each with a radio button. The Host Info section is active, showing a table with parameters: Interface (WAN), Port No (5060), Transport (UDP), UseProxy (NO), and Max Digits (14). Below this are fields for Host (N/C) and Port No (N/C) in the Proxy / Registrar Info section, and Domain (N/C) in the Domain Info section. The CODECs Info section shows PCMU (selected), PCMA (selected), and G729 (selected). A REGISTER STATE section contains a field for DIRECT_CALL. At the bottom are 'Config' and 'Modify' buttons.

The screen allows the following actions to be performed. Their configurations are described in the following sections.

- Local: VoIP host/voice CODEC configuration for the Gateway, and SIP proxy/registrar configuration if necessary.
- PhoneList: SIP phone number configuration for the Gateway.
- Remote: Buddy phone number configuration. The Gateway looks up the buddy list for the dialed phone number first. If the phone number is not listed, then the Gateway queries the SIP proxy. This setting is also suitable for peer-to-peer calling in cases where there is no SIP Registrar/proxy.
- CallForward: Call forwarding configuration.

5.2 Local

The Local tab configures the local terminal parameters. The page displays the SIP Configuration List. To configure the local parameters, you can click on the **Config** button or **Modify** button. The Config button changes all the local parameters based on the default settings. The Modify button configures the parameters for the selected part.

The screenshot shows the 'Local' tab selected in a navigation bar. Below the navigation bar, the title 'SIP Configuration List' is centered. The main content area contains several sections, each with a radio button and a table of parameters:

- Host Info:** A table with columns: Interface (WAN), Port No (5060), Transport (UDP), UseProxy (NO), and Max Digits (14).
- Proxy / Registrar Info:** A table with columns: Host (N/C) and Port No (N/C).
- Domain Info:** A table with column: Domain (N/C).
- CODECs Info:** A table with columns: PCMU (selected), PCMA (selected), and G729 (selected).

Below these sections is a 'REGISTER STATE' section with a table containing the value 'DIRECT_CALL'. At the bottom of the form are two buttons: 'Config' and 'Modify'.

The following screen appears when you select **Config**.

The screenshot shows the 'Local' tab selected in a navigation bar. Below the navigation bar, the title 'SIP Configuration' is centered. The main content area contains several sections, each with a heading and input fields:

- Config Host:** Interface (WAN), Transport (UDP), Max Digits (14), Port No (5060), and Use Proxy (NO).
- Config Proxy/Registrar:** Host Addr (empty text box) and Port No (5060).
- Config Domain:** Domain (empty text box).
- Config Codecs:** Checkboxes for PCMU, PCMA, and G729, all of which are checked.

At the bottom of the dialog box are two buttons: 'Apply' and 'Cancel'.

Config Host

Enter or select the SIP host parameters:

Interface	Choose an interface over which the SIP host will transmit /receive the SIP messages. The WAN interface is mandatory and there are no other selectable options.
Transport	Choose the transport protocol. It can be either UDP or TCP. The default is UDP. Presently only UDP is supported.
Max Digits	The limited maximum number of digits allowed.
Port No	Port number of user-agent where it receives the SIP messages. The default port number is 5060, which is a well-known port for SIP protocol.
Use Proxy	Choose YES if a Proxy or Registrar server will be used. Also configure the Proxy Info and Registrar. Choose No if a Proxy/Registrar server won't be used. With this setting, the proxy and registrar information will be ignored.

Config Proxy/ Registrar

This section configures the proxy server IP address and port number. A proxy is an intermediary program that acts as both a server and a client for the purpose of making requests on behalf of other clients. Requests are serviced internally or transferred to other servers. A proxy interprets and, if necessary, rewrites a request message before forwarding it.

- Host Addr: IP address of the SIP proxy server, used for VOIP service.
- Port No: Port number of the SIP-Proxy server. The default port number is 5060.

Domain Information

This section configures the Registrar Server IP address and port number. A Registrar server accepts REGISTER requests. A registrar is typically collocated with a Proxy or Redirect server and may offer location services. The Registrar saves information about where a party can be found.

- Domain: domain name of the SIP Registrar server.

CODECs Information

This section configures the Codecs to be supported for the configured User-Agent. PCMU (*u-law*), PCMA (*a-law*), and G.729 are the codecs which can be selected. Multiple items can be checked. The final CODEC is up to the negotiation with the party or SIP proxy.

5.3 PhoneList

The PhoneList tab lists and configures the local phone parameters. This section configures the SIP parameter required to build SIP messages for the phone attached to the Gateway to send signaling information to the other party. When a call is received, the Gateway checks whether the called number matches any of the entries in the phone port list. If no entry is matched, the call request is dropped. The 1813 VoIP Gateway supports an FXS port for phone service and there is a single entry, Port No. 1, in the phone list.

Select	Port No	User Name	Display Name	Expire	QValue	Codec	DTMF	Packetization Period	Auth UserName	Auth Password
<input checked="" type="radio"/>	1	801	801	120	0.8	PCMU	N/C	20	N/C	N/C

Port No	This displays the port number. Port No. 1 is mandatory and is not selectable.
User Name	Name of the local SIP host. When a call is received, the host checks whether the called number matches the entry in the phone port list. If it is not matched, the call request will be dropped.
Display Name	The name displayed on phone sets that support the Caller ID function, when you call them. It is for identification purposes only, and can be used to hide or show the actual user name.
Expire:	The time period the user's registration is valid with the Registrar/Proxy Server. The default value is 120 seconds.
Qvalue	Enter a value between 0 and 1 for registering with the proxy (in case the same username is registered from a different location). Decimals are accepted, such as 0.3. In general, a larger number has higher priority for the proxy to connect the call. If the same Qvalue is used, the call connection is up to the call policy of the proxy.
Codec:	The preferred codec of this user. The default is PCMU first.

DTMF	The DTMF method is inband.
Packetization Period	The period of time that the voice packets are packetized. The value always shows 20 milliseconds.
Auth User Name	The authentication user name for the Registrar/proxy, which is assigned by the service provider.
Auth Password	The authentication password for the Registrar/proxy, which is assigned by the service provider.

The **Register** button allows the user to manually make the Gateway register with the remote proxy server. The **Modify** button changes the phone parameters.

If the **Register** button is not clicked on after modification of phone information, the Gateway will automatically register with the remote proxy until the expiration of timeout (120 seconds by default). It is recommended to execute the **Register** button after any modification in order for the proxy to keep the up-to-date phone information of the Gateway.

The screenshot shows a web interface for modifying phone information. The interface is titled "Phone Info Modification" and is part of a larger system with tabs for "Local", "PhoneList", "Remote", and "CallForward". The "PhoneList" tab is active. The form contains the following fields and values:

- Port No : 1
- User Name : 801
- Display Name : 801
- Auth. User Name :
- Auth. Password :
- Expire : 120
- QValue : 0.8
- Pack. Period : 20
- Codec : PCMU
- DTMF : in-band

At the bottom of the form are two buttons: "Apply" and "Cancel".

5.4 Remote

The Remote tab configures the buddy list. The Gateway looks up the buddy list for the dialed phone number first. If the phone number is not listed, then the Gateway queries the SIP proxy. It is also suitable for peer-to-peer calling in cases without a SIP Registrar/proxy. For the case without a SIP Registrar/proxy, the host phone port can't call the user agent that is not in the buddy list.

User Name	Name of the remote SIP host, which should be the name of peer SIP host.
Speed Dial	The phone number maps to the remote party SIP-URI after dialing on key/phone pad. This should be unique for different SIP-URI.
HOST	The host IP address to call.
Port No	Port number of the remote user agent where it will receive SIP messages. The default port number is 5060, which is a well-known port for SIP protocol.
Display Name	The name displayed on phone sets that support the Caller ID function. It is for identification purposes only, and can be used to hide the actual user name.

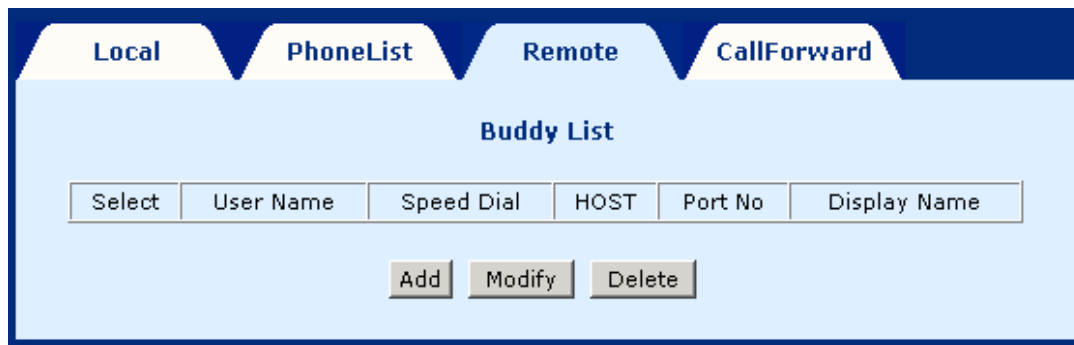

Add

New buddy entries can be added using the **Add** button. After entering the parameters, click on **Add** to submit the settings.

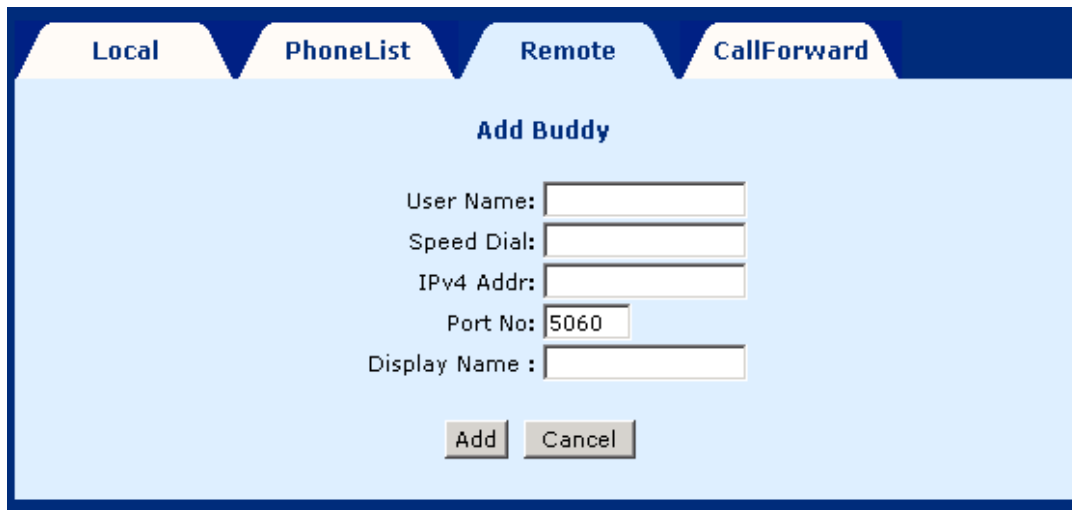

The screenshot shows a web interface with four tabs: Local, PhoneList, Remote, and CallForward. The 'Remote' tab is selected. The main content area is titled 'Add Buddy' and contains the following fields:

- User Name:
- Speed Dial:
- IPv4 Addr:
- Port No:
- Display Name:

At the bottom of the form are two buttons: 'Add' and 'Cancel'.

Modify

Select the entry by ticking it in the Select field and click on **Modify** (see the following figure). After changing the parameters, click on **Modify** to submit the settings.

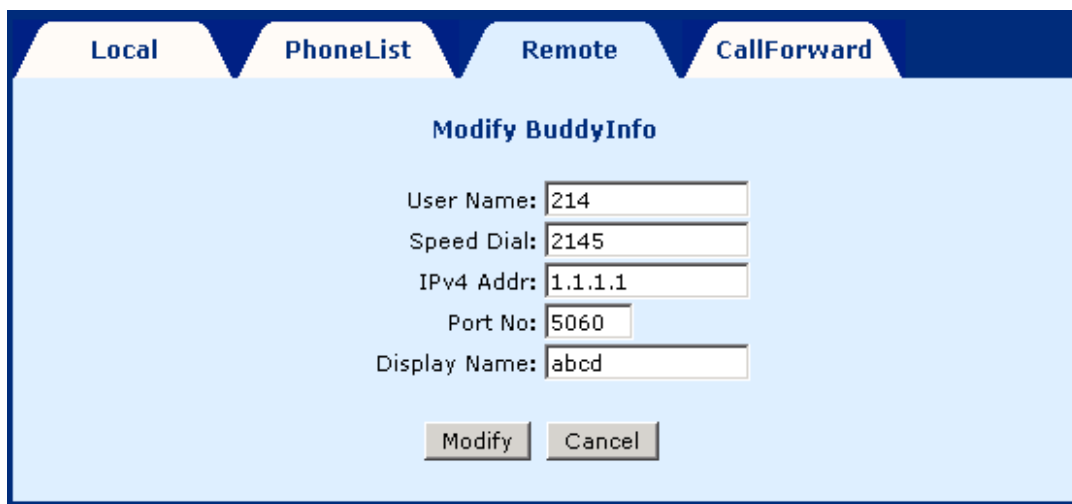

The screenshot shows the same web interface as above, but with the 'Modify BuddyInfo' form displayed. The fields are pre-filled with the following values:

- User Name:
- Speed Dial:
- IPv4 Addr:
- Port No:
- Display Name:

At the bottom of the form are two buttons: 'Modify' and 'Cancel'.

Delete

Select the entry by ticking it in the Select field and click on **Delete**.

5.5 CallForward

This CallForward tab lists the configured call forward information.

The screenshot shows a web interface with four tabs: Local, PhoneList, Remote, and CallForward. The CallForward tab is active, displaying a table titled "Phone Call Forward List". The table has seven columns: Select, Phone No, User Name, HOST, Port No, Fwd Call, and Fwd Uncond. There is one row of data with values: a radio button, 1, N/C, N/C, N/C, No, and No. Below the table is a "Modify" button.

Select	Phone No	User Name	HOST	Port No	Fwd Call	Fwd Uncond
<input type="radio"/>	1	N/C	N/C	N/C	No	No

To configure the call forwarding parameters, tick the item and click on Modify. After changing the parameters, click on **Modify** to submit the settings.

The screenshot shows the "Modify Call Forward Info" form. It has six input fields: Phone No (text box with '1'), User Name (text box), IPv4 Addr (text box), Port No (text box with '5060'), Fwd Call (dropdown menu with 'NO' selected), and Fwd Uncond (dropdown menu with 'NO' selected). At the bottom are "Modify" and "Cancel" buttons.

Phone No	Displays the selected phone port number for configuration. (Port No. 1 is mandatory and is not selectable.)
User Name	Sip user name of the forwarding address where the calls will be forwarded.
IPv4 Addr	The IP address of the SIP user name to which the phone calls will be forwarded.
Port No	Port number of the forwarding address where the calls will be forwarded. The default port number is 5060.
Fwd Call	Choose YES if the phone will be forwarded. Choose NO if the phone will not be forwarded.

Chapter 6 Performance Monitoring

6.1 System Statistics

To view the system statistics, click on the **System Statistics** button located near the bottom of the menu bar. Statistics are recorded regarding Interfaces and TCP-IP.

6.1.1 Interface Statistics

To display the interface statistics, click on the **Interfaces** tab, located at the top-left of the System Statistics screen. The Interface Statistics page displays statistics for all interfaces.

Interface Name	Admin Status	Octets In	Unicast PktsIn	Broadcast PktsIn	Discards In	Errors In	Octets Out	Unicast PktsOut	Broadcast PktsOut	Discards Out	Errors Out
LAN	UP	16819	204	1	0	0	9469	24	0	0	0
WAN	UP	0	0	0	0	0	0	0	0	0	0

The following information is displayed:

Interface Name	The name of the interface
Admin Status	Indicates whether the interface is Up or Down
Octets In	The number of Octets (bytes) received
Unicast PktsIn	The number of unicast packets received
Broadcast PktsIn	The number of broadcast packets received
Discards In	The number of packets received that were discarded
Errors In	The number of inward errors
Octets Out	The number of Octets (bytes) transmitted
Unicast PktsOut	The number of unicast packets transmitted
Broadcast PktsOut	The number of broadcast packets transmitted
Discards Out	The number of packets transmitted that were discarded
Errors Out	The number of outward errors

6.1.2 TCP-IP

To view TCP-IP statistics click on the **TCP-IP** tab at the top of the System Statistics page. The TCP-IP page displays the IP statistics, UDP statistics, TCP statistics, and ICMP statistics.

Interfaces		TCP-IP	
TCP-IP Statistics			
IP Statistics			
In receives	1265	In Errors	0
Out Requests	169	Out Discards	0
In Unknown Protos	158	Forwarded Datagrams	169
Out No Routes	0		
Udp Statistics			
Data grams In	919	Datagrams Out	0
Errors In	0		
Tcp Statistics			
Active Opens	0	Passive Opens	14
Segments In	181	Attempt Fails	0
Segments Out	157	Current Establishments	3
Segments retransmitted	0	Errors In	0
Icmp Statistics			
IN			
Messages	30	Errors	0
Source Quenches	0	Destination Unreaches	0
Redirects	0	Echos	4
Time Exceeds	0	Echo Replys	4
OUT			
Messages	4	Errors	0
Source Quenches	0	Destination Unreaches	0
Redirects	0	Echos	0
Time Exceeds	0	Echo Replys	4

6.1.3 Ping

To access the Ping screen, click on the **Ping** button, which is located under the Advanced menu bar. This screen performs the ping test.

A ping test is used to verify the status of a network connection after the RIP or static route function is enabled. Ping sends a request message to the host and waits for a return message. This function can verify if the remote host is reachable. Ping can also measure the round-trip time to the remote host. To access the Ping test screen, click on the **Ping** tab. Enter the **Host Name** or **IP address** of the remote terminal and click on **Submit** to start the ping and display the results.

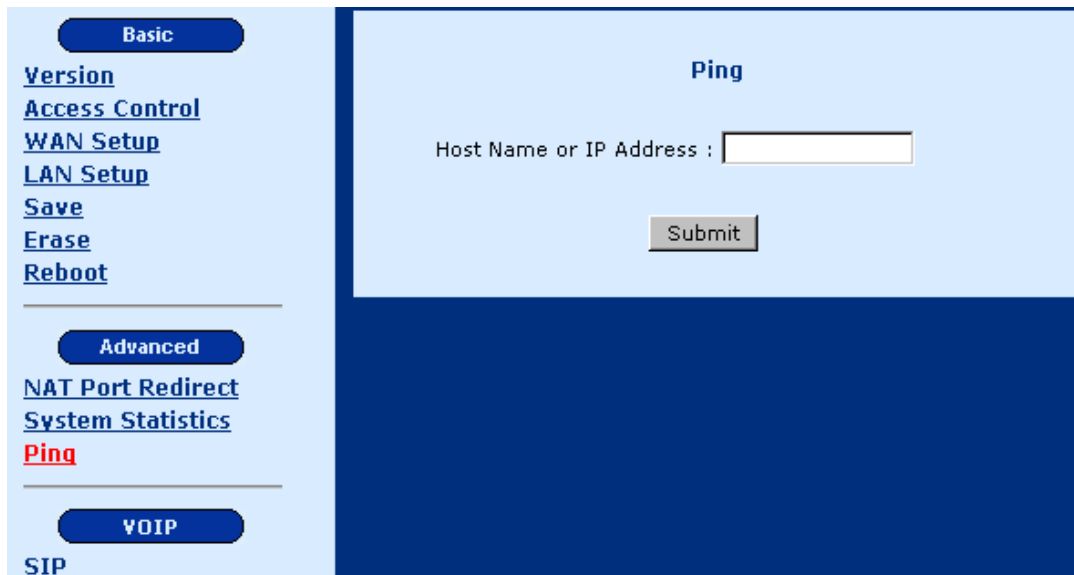

The screenshot shows a web-based configuration interface for a VoIP Gateway. On the left side, there is a navigation menu with several sections: 'Basic' (containing links for Version, Access Control, WAN Setup, LAN Setup, Save, Erase, and Reboot), 'Advanced' (containing links for NAT Port Redirect, System Statistics, and Ping), and 'VOIP' (containing a link for SIP). The 'Ping' link is highlighted in red. The main content area is titled 'Ping' and contains a text input field labeled 'Host Name or IP Address :'. Below the input field is a 'Submit' button.

The following is an example of the ping result.



The information returned is as follows:

Packets transmitted	The number of packets that were transmitted.
Packets received	The number of packets that were received.
Packet loss (%)	The percentage of packets lost (transmitted and received)
Minimum round trip time	The fastest round-trip time.
Maximum round trip time	The slowest round-trip time.

Chapter 7 Software Upgrade via FTP

Follow the steps below to upgrade the firmware version of the Gateway via FTP.

The procedures below use LAN port IP address 192.168.1.101 for illustration.

STEP 1: Connect the Gateway to a PC using the LAN cable. Set the PC to the same subnet as the Gateway (192.168.1.101).

STEP 2: Start an FTP program on the PC.

STEP 3: Start DOS and enter the menu where the new firmware is installed:

```
Example: C:\Upgrade
```

STEP 4: Enter the command: ftp 192.168.1.101 (Gateway's IP address)

```
C:\>ftp 192.168.1.101
```

STEP 5: At the USER prompt type **root** (small case)

```
Connected to 192.168.1.101
220 Welcome to the update FTP server v1.0.
User (192.168.1.101 : (none)) : root
```

STEP 6: At the Password prompt type **1234**

```
331 Password required for root .
Password:
```

STEP 7: After you see the message **User Logged in**, type: **Bin**

```
230 User logged in.
ftp> Bin
```

STEP 8: After you see the message **Type set to I**, type: **ha**

```
200 Type set to I.
ftp> ha
```

STEP 9: After you see the message **Hash mark printing**, type:

```
put <filename.bin> app
```

Example: put firmware app

```
ftp> put firmware app
```

Appendix A: Specifications

WAN Interface

Ethernet x 1 IEEE 802.3 10/100 Base-T, Auto-crossing

LAN Interface

Ethernet x 3 IEEE 802.3 10/100 Base-T, Auto-crossing

Analog Interface

FXS x 1

Management

Telnet, Web-based management

Software upgrade via TFTP client or FTP server

Routing Functions

Default gateway Static route, NAT/PAT, DHCP Server/DHCP client, DNS, ARP

Security Functions

Authentication protocols PAP, CHAP,

VPN features PPTP/L2TP/IpSec pass-through

Voice Functions

SIP RFC 3261

H.323, H.323, H.225, H.245

Codec G.711, G.723.1, G.729ab

RTP RFC 1889

SDP RFC 2327

On/Off hook Caller ID ETSI based

Echo cancellation G.168

Silence suppression G.711, G.723.1, G.729ab

LED

WAN, LAN 1x, LAN 2x, LAN 3x, PHONE

Power Supply

The universal power adapter of the Gateway supports 110–240Vac.

The linear power adapter of the Gateway supports 110 or 220Vac.

Environmental Conditions

Operating temperature 0 – 50 degrees Celsius

Relative humidity 5 – 90% (non-condensing)

Dimensions

150 mm (W) x 42 mm (H) x 140 mm (D)

5.9 in (W) x 1.7 in (H) x 5.5 in (D)

Appendix B: Pin Assignments

LAN Port (RJ45 Auto-cross)

Pin number	Definition	Pin number	Definition
1	Transmit data+	5	NC
2	Transmit data-	6	Receive data-
3	Receive data+	7	NC
4	NC	8	NC

Appendix C: Troubleshooting

Event	Checking Procedure or possible cause
Unable to access the Web management	Check the LAN connection. Check your PC's TCP/IP setup
Web login reject	Check your password. The default user name is root; the default password is 1234 . The user name and password are case sensitive.

Appendix D: GLOSSARY

100BaseT: A 100 Mbps Ethernet standard that uses twisted-pair wiring.

10BaseT: A 10 Mbps Ethernet standard that uses twisted-pair wiring.

address: The symbol (usually numeric) identifying an interface attached to a network.

ADSL: An asynchronous form of DSL in which the bandwidth available for downstream connection is significantly larger than for upstream.

analog loop: A test in which a modem's voice signal is looped to its receiver.

analog signal: A continuously variable signal (compare with digital).

Annex A: The part of the G.992.1 standard that refers to ADSL over POTS (adopted by the US).

Annex B: The part of the G.992.1 standard that refers to ADSL over ISDN (adopted by Europe)

Annex C: The part of the G.992.1 standard that refers to ADSL over ISDN (adopted by Japan).

ANSI: American National Standards Institute.

ASCII: American Standard Code for Information Interchange.

attenuation: The loss of power of a transmitted signal as it travels over a wire.

auto-summary: A RIP command to restore the default behavior of automatic summarization of subnet routes into network-level routes.

backbone: The main circuit that carries data before it is split into extended circuits going to their

final destination. Often used to refer to the part of the network that joins LANs together.

bandwidth: The range of frequencies of a transmission channel. The wider the range the higher the data rate that can be sent. Hence, bandwidth is also taken to mean the data rate.

Baud: One baud is one symbol (state-transition or level-transition) per second.

BERT: Bit Error Rate Test. A test that compares a received pattern with a known transmitted pattern to determine the quality.

Bit: A binary digit, with the value of 0 or 1.

boot: Start a device.

Bps: Bits per second. The speed at which bits are transmitted across a data connection.

bridge: A device that links local or remote area networks together, forwarding packets based on a MAC address (compare with Gateway).

broadband: Communication channels operating at transmission rates in excess of 64 kbps.

broadcast: The simultaneous transmission to two or more communication devices.

BT: Burst Tolerance. The limit parameter of the Generic Cell Rate Algorithm (GCRA).

buffer: A temporary storage used to compensate for a difference in the rate of flow of data.

bus: An assembly of conductors that carries signals to and from devices along its path and serves as a common connection for a group of related devices.

busy: A device's operational state, when the device is occupied with processing a call.

Byte: Eight bits arranged in sequence.

channel: A bi-directional communications pathway between a host server and a client.

CHAP: Challenge-Handshake Authentication Protocol. A PPP protocol to ensure authentication of the connection between two devices.

circuit: A logical connection between two devices.

CO: Central Office, the local telephone exchange, also called PSTN.

COM port: A computer's serial communications port.

CPE: Customer Premises Equipment. Equipment used by the end user.

cross talk: Undesired coupling of a signal from one circuit, or channel, to another.

data rate: The speed measured in bits per second that data is transferred over the carrier line.

Default: A pre-defined original value.

demodulation: The recovery, from a modulated carrier, of a signal.

DHCP server: A server that dynamically allocates network addresses and delivers configuration parameters to hosts.

DHCP: Dynamic Host Configuration Protocol. A TCP/IP protocol that enables a network connected to the Internet to automatically assign a temporary IP address to a host when the host connects to the network.

digital signal: A discrete or discontinuous signal where the states are discrete intervals apart, such as +10 volts and -10 volts. These states are then represented by the binary digits 0 and 1.

digital: loopback test: A test that connects the device's receiver output back to the transmitter input. This test will disrupt the transmission of primary data.

DLL: Dynamic Link Library. DLLs are files that are automatically loaded into memory when required.

DMT: Discrete MultiTone. The T1.413 standard modulation scheme for Digital Subscriber Line technology.

DNS: Domain Name Server. A server that retains the addresses and routing information for TCP/IP PAT users.

download: To receive a file over a network (compare with upload).

driver: A software module that provides an interface between a network interface card and the upper-layer protocol software running on a computer.

DSL: Digital Subscriber Line. A family of broadband services provided over a traditional phone line, such as ADSL, SHDSL, and VDSL.

DSP: Digital Signal Processor. The microprocessor that handles line signaling in a modem.

DTE: Data Terminal Equipment. Equipment that transmits or receives data in the form of digital signals.

dynamic detection: A process of a automatic detection of a new device added or removed from the PC.

EOC: Embedded Operations Channel. An in-band channel between DSL devices that operates at the physical layer for administration and maintenance data.

error control: An algorithm used to detect and correct data transmission errors.

errored second: An item in performance measurement report, which pertains to a one second period with one or more errored blocks.

Ethernet address: Another name for MAC address.

Ethernet: A standard protocol (IEEE 802.3) for a 10-Mb/s baseband local area network (PAT) bus that supports high-speed communication among systems. It operates at the Physical Layer of the OSI Model.

ETSI: European Telecommunications Standards Institute.

FCC: Federal Communications Commission of the United States.

filter: A configuration that stops the flow of certain types data frames.

firmware: Software that has been temporarily or permanently loaded into ROM.

flash memory: A type of RAM that retains its information, even after powering-down.

flow control: A process that uses buffers to stop and start the flow of data in a network to avoid losing data, and allow devices with different transmission schemes to communicate with each other.

FTP: File Transfer Protocol. A TCP/IP standard protocol for transferring files.

full-duplex: transmitting in two directions simultaneously.

G.991.2: An ITU-T specification for high speed DSL known as G.SHDSL.

G.DMT: Another name for the G.992.1 ITU specification.

G.lite: Another name for the G.992.2 ITU specification.

gateway: A communications device that connects two different networks.

header: The beginning of a frame or cell that contains management and addressing information.

hop: One point-to-point transmission in a series required to transmit a message between two hosts in a network.

host: An addressable computer connected to a network.

hub: A device that serves as the central location for attaching wires from workstations.

ICMP: Internet Control Management Protocol. An Internet protocol that allows for the generation of error messages, tests packets, and information messages related to IP.

ISDL: A form of ISDN DSL using 2B1Q line code.

IEEE: Institute of Electrical and Electronics Engineers.

IEEE: The Institute of Electrical and Electronics Engineers.

ILMI: Interim Local Management Interface. Provides ATM layer management between a switch and a client device.

IP address: Internet Protocol address. The decimal-numeric, fixed-length address assigned to an Internet host.

IP multicast: A technique that allows packets to be simultaneously transmitted over the Internet to multiple destinations.

IPOA: IP over ATM.

IRQ: Interrupt re-quest, a hardware interrupt on a PC.

ISO: International Standards Organization.

ISP: Internet Service Provider. An organization that provides access to the Internet.

ITU: International Telecommunications Union. The telecommunications agency of the United Nations.

kbps: Kilobits per second.

LAN: Local Area Network. A LAN is a data communications system that lies within a limited spatial area, has a specific user group, and has a specific topology.

latency: The time it takes a signal to transmit from its source to its destination.

LED: Light Emitting Diode. A light or status indicator.

LOC: Loss of Cell delineation. A situation where receiving equipment is unable to identify the boundaries of a cell.

local analog loopback: A test in which the modem's VF signal is looped to its receiver.

local loop: An ordinary telephone line.

local loopback test: An analog loopback test that loops a device's transmitter output back to receiver input.

loopback: A diagnostic procedure where a test message is sent back to its origination point, in order to isolate an equipment or data line problem.

LOS: Loss of Signal. A digital line condition where there are no pulses.

MAC address: Media Access Control address. The unique fixed address of a piece of hardware, normally set at the time of manufacture and used in PAT protocols.

MAC: Medium Access Control, a protocol for determining which device has access to the network at any one time.

Mbps: Megabits per second. One megabit is 1,048,576 (10242) bits.

MCU: Multi-Commercial Unit. A commercial building or complex with multiple tenants.

MDU: Multi-Dwelling Unit. A residential building with multiple tenants.

MIB II: MIB Release 2. An update of the MIB standard, defined by RFC 1213.

MIB: Management Information Base. A database of managed objects used by network management protocols to provide network management information and device control.

modem: Modulator Demodulator. A device used to convert a digital signal into an analog signal and vice-versa so that data can be transmitted over a telephone line.

modulation: The process of varying the amplitude, frequency, or phase of a carrier wave to form data transmissions.

multicasting: The ability of a network node to send the same data to multiple endpoints.

multiframe: An ordered, functional sequence of frames on a multiplexed digital circuit.

NAT: Network Address Translation is a transparent routing function that translates a Private IP address on a PAT into a Public address that can be used in a public network.

network address: The network portion of an IP address.

network protocol: Network protocols encapsulate and forward data packets from one interface to another.

NIC: A Network Interface Card is a card installed in a device to provide network communication capabilities to and from that device.

node: A connection or switching point in a network, also called a host.

noise: Unwanted interference to a transmitted signal by an outside source.

PAP: Password Authentication Protocol. PPP protocol that ensures authentication of the connection between two devices.

PAT: Port Address Translation is a form of NAT that maps multiple Private IP addresses to a single Public IP address.

ping: An internet utility signal sent to check the accessibility of a device.

Plug-and-Play: The ability of a PC to configure expansion boards and other devices automatically without requiring the user to turn off the system during installation.

point-to-point connection: Any connection with only two endpoints. A dedicated data link that connects only two stations.

poison reverse: A routing protocol command that tells its neighbor gateways that one of the gateways is no longer connected.

POP: Point Of Presence.

Port: An access point where data can enter or exit.

POTS: Plain Old Telephone Service.

PPP over ATM: Point-to-Point Protocol over Asynchronous Transfer Mode.

PPP: Point-to-Point Protocol. A protocol (RFC 1661) for transmitting packets over serial links between devices made by the same or different manufacturers.

PPPoE: Point-to-Point Protocol over Ethernet. A method for establishing sessions and encapsulating PPP packets over an Ethernet, specified by RFC 2516.

PPTP: Point-to-Point Tunneling Protocol. An extension of Point-to-Point Protocol used to create virtual private networks between PCs.

protocol: A set of rules that govern the transmission of data between interconnected devices to maintain or improve communication.

proxy server: Provides a list of items available on other servers to increase the availability and speed of retrieving that information.

PSTN: Public Switched Telephone Network. The standard telephone network.

PVC: Permanent Virtual Circuit. Virtual circuit that is permanently established.

QoS: Quality of Service. The expected data loss or latency.

remote access: Communication from a remote location or facility through a data link.

remote digital loopback test: This test loops the remote digital receiver output back into the transmitter input.

remote host: The computer receiving the network commands.

RFC: Request for Comments. Documents published by the Internet Engineering Task Force pertaining to Internet protocols and policies.

RIP: Routing Information Protocol. The protocol governing the exchange of routing information.

RJ11: A 6-position jack used with dial networks and telephone sets.

RJ45: An 8-position jack used with programmable dial networks.

router: Protocol-dependent device that connects subnets together. Routers operate at the network layer (layer 3) of the ISO Open Systems Interconnection Reference Model.

routing table: A table that lists routing paths to enable a node to route traffic to another node in the network.

RS-232: a low-speed, 25-position, DCE/DTE interface.

server: Hardware or software that offers a specific service, such as database management, to a client.

SHDSL: Symmetric High Bit Rate Digital Subscriber Loop. A DSL technology that allows symmetrical transmissions over longer distances. Defined by the G991.2 ITU standard.

SLA: Service Level Agreement. A contract between a service provider and a customer, which guarantees a minimum level or quality of service to the customer.

SMTP: Simple Mail Transport Protocol. A protocol used to transfer e-mail between or among servers.

SNMP agent: An application program that enables communication between a management system and a device.

SNMP trap: A message sent to a SNMP manager to communicate information about changes in the network, such as a device being reset.

SNMP: Simple Network Management Protocol. Protocol for open networking management.

static route: A route that is permanent rather than a route that is dynamically assigned by another router.

STP: Shielded Twisted Pair. Telephone wire that is wrapped in a sheath to eliminate external interference.

subnet address: The subnet portion of an IP address.

subnet mask: A number that identifies the subnet portion of a network address. so that IP addresses can be shared on a local area network.

subnet: An independent network segment, that is, it has the same network address, but its subnet address is different.

switch: A data switch connects computing devices to host computers, enabling multiple devices to share a limited number of ports. An electrical switch is a device for making, breaking, or changing the connections in an electrical circuit.

synchronous transmission: Transmission with the transmitter and receiver synchronized so that data is transmitted at a fixed rate.

synchronous: Any operation that is controlled by a clock or timing mechanism. (*Compare with asynchronous*).

TCP/IP: Transmission control protocol/Internet protocol, a set of protocols that govern peer-to-peer connectivity functions for local and wide area networks.

TCP: Transmission Control Protocol.

Telnet: The TCP/IP virtual terminal protocol that allows a user at one site to access a remote system at another site.

throughput: The number of bits, characters, or blocks that are able to pass through a data communication system.

training: A process where two modems try to determine the correct protocols and transmission speeds to establish a communication session.

trellis-coded modulation: Advanced error correction coding technique for forward error correction to a modulation scheme by adding an additional bit to each baud.

UDP: User Datagram Protocol. A connectionless protocol that converts data messages generated by an application into packets to be sent over IP.

UNIX: An operating system developed at AT&T Bell Laboratories.

upload: To receive a file transmitted over a network.

URL: Uniform Resource Locator. An Internet standard addressing protocol for describing the location and access method of a resource on the Internet.

USB: Universal Serial Bus. A bi-directional, isochronous, serial interface for adding dynamically connectable peripheral devices, without the need for a reboot.

UTP: Unshielded twisted pair is the most common kind of copper telephone wiring.

VC: Virtual Circuit. A logical connection or packet-switching mechanism established between two devices at the start of transmission.

VCI: Virtual Channel Identifier. The 16-bit field in an ATM cell header that specifies the virtual channel over which the cell is to be transmitted.

VDSL: Very-high-speed DSL. A DSL protocol running at up to 52 Mbps, that is restricted to short distances.

virtual circuit: A logical circuit established between two devices at the start of transmission

VOD: Video On Demand. A service that provides video to subscribers upon request.

VPI: Virtual Path Identifier

VPI: Virtual Path Identifier. The 8-bit field in an ATM cell header that specifies the routing path for a cell.

VPN: Virtual Private Network. A network implemented over a public network that is made “private” by use of encryption.

VT100: A terminal used for asynchronous communications.

WAN: Wide area network. A communications network that connects geographically separated areas (Compare with LAN).

xDSL: A generic term for all varieties of DSL.

XOFF: A character that notifies a device to stop transmitting data.

XON: A character that notifies a device to start or resume transmitting data.

Free Manuals Download Website

<http://myh66.com>

<http://usermanuals.us>

<http://www.somanuals.com>

<http://www.4manuals.cc>

<http://www.manual-lib.com>

<http://www.404manual.com>

<http://www.luxmanual.com>

<http://aubethermostatmanual.com>

Golf course search by state

<http://golfingnear.com>

Email search by domain

<http://emailbydomain.com>

Auto manuals search

<http://auto.somanuals.com>

TV manuals search

<http://tv.somanuals.com>