

OPERATING INSTRUCTIONS

CD - RECEIVER

K1



Dear fellow Hi-Fi enthusiast,

The new **T+A K1 CD-RECEIVER** you have just purchased is a Hi-Fi system of the highest quality, designed and developed with a single aim as top priority: to meet the wishes of the audiophile music lover.

The machine's solid, well thought-out design, and its synthesis of a user-friendly control system and the very latest technical features help to make this a piece of equipment which will satisfy your highest demands and your most searching requirements for a period of many years.

All the materials we employ are subject to painstaking quality monitoring. Our production areas are supervised by highly qualified, expert staff, and all final production units are checked comprehensively by a fully automated, computer-controlled system to ensure uniformly high quality. We guarantee that our products meet our own specifications in full.

At all stages of production we avoid the use of substances which are environmentally unsound or potentially hazardous to health, such as chlorine-based cleaning agents and CFCs.

We also aim to avoid the use of plastics in general, and PVC in particular, in the design of our products. Instead we rely upon metals and other non-hazardous materials; metal components are ideal for recycling, and also provide effective electrical screening.

The robust all-metal cases which we use offer a real and practical advantage, since they exclude any possibility of external sources of interference affecting the quality of reproduction.

From the opposite point of view our products' electro-magnetic radiation (electro-smog) is reduced to an absolute minimum by the outstandingly effective shielding provided by the metal case.

We would like to take this opportunity to thank you for the faith you have shown in our company in purchasing this product, and wish you many hours of enjoyment and sheer listening pleasure with your **T+A K1 CD-RECEIVER**.

T+A elektroakustik GmbH & Co KG

CE All the components we use meet the currently valid German and European safety norms and standards. To give yourself security please read through these operating instructions and follow the relevant information for installation, use and security exactly

This product complies with the Low Voltage Directive (73/23/EEC), EMV Directives (89/336/EEC, 92/31/EEC) and CE Marking Directive (93/68/EEC).

IMPORTANT! CAUTION!

This product contains a laser diode of higher class than 1. To ensure continued safety, do not remove any covers or attempt to gain access to the inside of the product. Refer all servicing to qualified personnel.

The following caution label appear on your device:

Rear panel

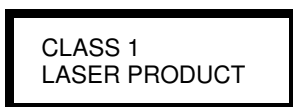

On the inner protective housing of the CD mechanism

CAUTION:	VISIBLE AND INVISIBLE LASER RADIATION WHEN OPEN. AVOID EXPOSURE TO BEAM
VORSICHT:	SICHTBARE UND UNSICHTBARE LASERSTRAHLUNG, WENN ABDECKUNG GEÖFFNET NICHT DEM STRAHL AUSSETZEN
ATTENTION:	RAYONNEMENT LASER VISIBLE ET INVISIBLE EN CAS D'OUVERTURE EXPOSITION DANGEREUSE AU FAISCEAU
DANGER:	VISIBLE AND INVISIBLE LASER RADIATION WHEN OPEN. AVOID DIRECT EXPOSURE TO BEAM

CONTENTS

Page	
6	Remote cotroll handset F12
8	Front panel controls
10	OPERATING THE AMPLIFIER
10	Controlling from the front panel
10	Volume control
10	Selecting the source unit
	Remote control
12	Switching on / Stand-by
13	Volume control
13	Speaker outputs
13	Loudness / Low bass equalisation
13	Selecting the source unit
14	Amplifier special functions
15	• Balance adjustment
16	• Tone control, treble / bass
17	• Set-up functions
18	Funct.1 Dimmer (Display brightness)
19	Funct.2 Setting the clock
20	Funct.3 Separate Volume adjustment (Single room / multi-room mode)
21	Funct.4 AUX / TV sensitivity
22	OPERATING THE TUNER
22	Controlling from the front panel
22	Preset selection, station search
22	Stereo indicator
22	Signal strength indicator
23	Timer
24	Remote control
24	Selecting the tuner as auditioning source
25	Selecting a preset and station
25	Numeric preset selection
26	Radiotext
26	Preset number and reception frequency
27	Tuner special functions
28	• Changing the reception mode
30	• Storing and erasing presets

Page	
33	OPERATING THE CD PLAYER
33	Controlling from the front panel
33	Playing a CD
33	Selecting a track during playback
34	Remote control
34	CD player as auditioning source
35	Controlling the CD mechanism
35	Stop - Pause – Play
35	Numeric track selection
36	MEMO program
38	CD player special functions
39	• Play A-B
40	• Play mode (Normal /Repeat / Mix)
41	• Track / Time display
42	Safety notes
44	Connection terminals on the K1
46	Connecting the system, the system in use
47	K1 wiring arrangement
48	Multi-room sound system
49	K1 wiring arrangement (multi-room)
50	Specification
52	Trouble-shooting
57	FCC information to the user

REMOTE CONTROL HANDSET F12

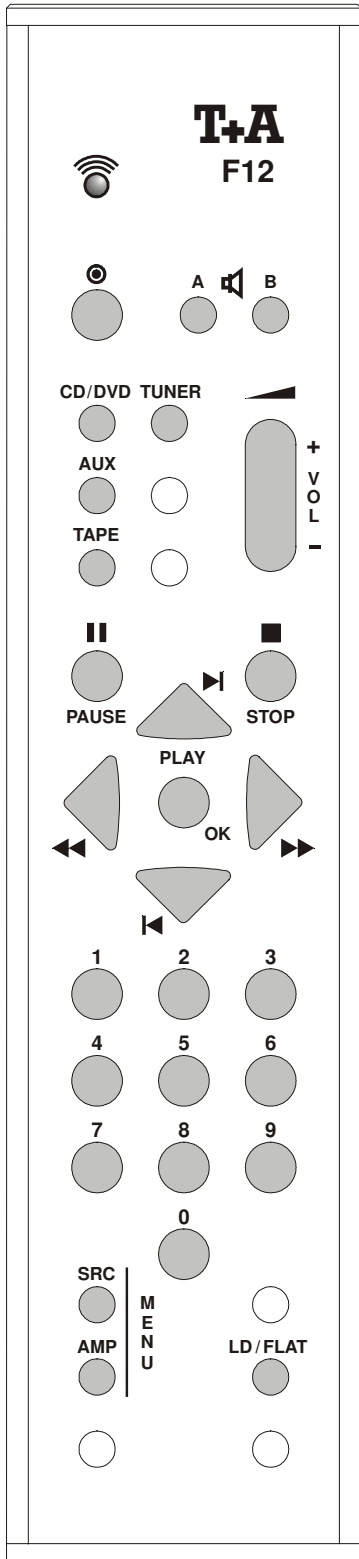





Your **K1** is supplied complete with an **F12** remote control handset. The relevant buttons are shaded in the diagram in like this: .

ON / OFF:

	Switches the unit ON from stand-by, or to stand-by from ON . The K1 must be switched on at the main ON/OFF switch for this to work.
---	---



Source select:

	Selects the integral CD player as listening source.
	Selects the integral tuner as listening source.
	Selects the device which is connected to the external socket AUX/TV as listening source.
	Selects a cassette recorder connected to the external TAPE input as listening source.

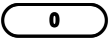
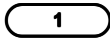
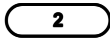
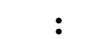
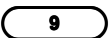
Numeric keypad:





	The numeric buttons are used for direct entry of pre-sets in tuner mode, and for direct track select in CD mode.
	
	
	
	

Pre-amplifier functions:

VOL +	Raises / lowers the volume in 1.25 dB increments.
VOL -	
A 	Switches the loudspeaker output A On / Off.
 B	Switches the loudspeaker output B On / Off.
LD / FLAT	Short keypress: Switches LOUDNESS On / Off.
	Long keypress (approx. 1 sec.): Switches low bass enhancement On / Off.





Mechanism and pre-set control:

These buttons are used to control the CD player and tuner.

	Skip track or pre-set, backwards.
	Starts CD playback; skip track or pre-set, forwards.
	Back, or increase frequency.
	Forward, or reduce frequency.
PAUSE	Switches CD to pause mode.
STOP	Halts CD playback.

Menu control:

SRC	Opens the separate menu of the current source device.
AMP	Opens the separate menu of the amplifier.

The buttons and rocker switches for the menu control system vary according to the mode currently selected. To move around within the menus you need to use the buttons , , ,  and **OK** in the mechanism control area.

Special functions

TUNER	In tuner mode this button switches radio text display for the current station ON/OFF.
CD / DVD	In CD mode this button switches the display from DIS TIME to DIS TRACK .

Battery compartment:

To open the battery compartment press in the latch on the underside of the remote control handset. And remove the cover. Place 3 new **LR03 (MICRO)** batteries in the holder following the engraved markings. Close the battery compartment.

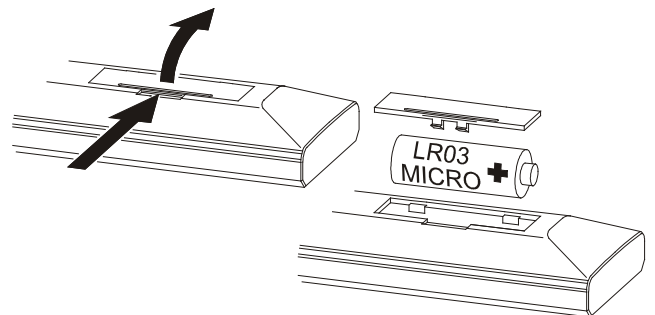

Changing the remote control level:

Press the buttons **OK** and **3** from the numeric pad for about 10 seconds. The LED will flash. Now press the numeric pad button **1** or **2**.

Number button **1** sets the remote control handset to the normal remote control level; number button **2** sets the alternative level. The LED will go out to confirm that the switch has taken place.

THE FRONT PANEL CONTROLS

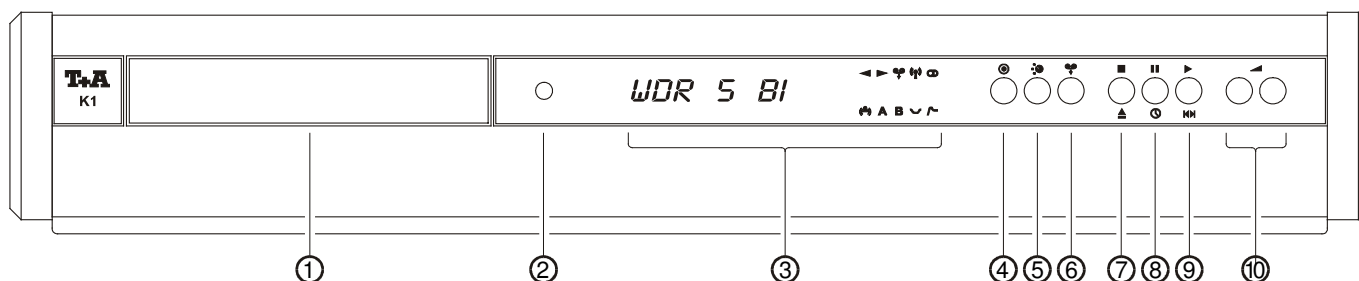

We have developed an overall methodology for controlling the system based on a small number of buttons, each of which has several functions depending on the situation.

To help you understand the system the buttons are duplicated by illuminated symbols which indicate their current function.

① CD DRAWER

Press the  button to open and close the CD drawer.

② HEADPHONES

Barrel socket (ø3.5 mm) for headphones, minimum impedance 50 Ω.

③ INFORMATION SCREEN

All the system's information displays are shown on a clearly legible screen, carefully laid out to make it easy to understand. At any one time the screen only shows the essential information relating to the current auditioning source (TUNER or CD). This helps considerably in avoiding confusion.

Operating trouble of the amplifiere is signaled by flashing symbols **A** and **B** (see trouble shootings).

The screen also shows supplementary information when required, i.e. seldom needed, machine-specific data. This information is shown in an alpha-numeric area, in plain language with the help of symbols. For further information please read the appropriate chapters.

④ ON

The system's On/Off button. When you switch the system on the screen shows the auditioning source you have selected, or a machine-specific message. When you switch on, the system is always in the setting in which it was last listened to. The volume is initially limited to "room level".

Caution:

The mains button is not a mains isolation switch. Even when the Ready indicator on the screen is not glowing, a few parts of the machine are still connected to the mains power supply. If the unit is not to be used for a long period it should be isolated from the mains by pulling out the mains plug at the wall socket.

⑤  **SOURCE SELECT**

The term source device means the components of a Hi-Fi system which supply a sound signal, such as tuner, CD player, cassette deck etc. Pressing the  button shows the system's currently active source device on the screen. Pressing this button repeatedly cycles through the available source devices

TUNER¹⁾ - **CD**¹⁾ - **TV**²⁾ - **TAPE**²⁾

¹⁾ Internal



²⁾ External

⑥  **MONITOR**

Pressing this button switches between the current auditioning source and the TAPE monitor, so that you can check the quality of the recording being made on a tape deck while the material is actually being recorded.

⑦  **STOP**

 **OPEN**

Combination button for ending CD playback ( = STOP) and for opening and closing the CD drawer ( = OPEN).

⑧  **PAUSE**

 **TIMER ON**

Pauses CD playback, i.e. the track currently playing is interrupted. Playback resumes when you press the button a second time.

The same button is used to switch the Timer on and off when the tuner has been selected as the auditioning source.

⑨  **PLAY**

 **BACK / FORWARD**

Combination button for starting CD playback, for jumping to a particular track and for changing presets when using the tuner.

A brief press starts the CD from STOP mode (PLAY function).

When the CD is playing, pressing this button jumps to the start of the next track, or selects the next preset.

Press this button for longer than 1 second to jump to the start of the preceding track. You can jump back several tracks in this way; in tuner mode hold it pressed in to select the preceding preset.

⑩  **VOLUME**

The machine features a digital volume control system. Every time you press the left-hand **VOLUME** button the volume level is reduced. Every time you press the right-hand **VOLUME** button the volume level is increased.

The current volume level is shown briefly on the screen. If you hold one of the **VOLUME** buttons pressed in for longer than a second, the volume alters continuously until you release the button again.

In Timer mode these buttons are used to adjust the alarm time.

OPERATING THE AMPLIFIER

VOLUME CONTROL

The machine features a digital volume control system. Every time you press a  button, the volume is ...

... increased (right-hand button)

or

... reduced (left-hand button) by 1.25 dB.

The current volume level is shown briefly on the screen as a numeric value (0 ... 63), e.g.:

'VOLUME 32'

The enormously wide range of volume levels (0 ... 78.75 dB) available, combined with the perfect channel matching, provide ultra-fine, highly accurate volume control.

SELECTING THE SOURCE DEVICE

The term source device means any component of a Hi-Fi system which supplies a sound signal, such as tuner, CD player, cassette deck etc.

The term auditioning device means the machine which you are actually listening to.

In addition to the integral auditioning sources **TUNER** and **CD** you can also select up to two external auditioning sources: **TV** and **TAPE**.

Press the  button briefly to change the auditioning device.

- The current auditioning source (e.g. Tuner) is now shown on the screen: **'TUNER'**.
- Pressing the  button repeatedly cycles through all the auditioning sources on the screen.
- Release the button to select the source you wish to listen to, and after one second the screen shows the standard machine-specific display for the chosen source unit.

As a basic rule you can only make a tape recording from the source device which is currently selected as the auditioning source.

This signal is available at the output sockets marked **TAPE-OUT**.

To switch between the auditioning source and the recording machine (i.e. for tape monitoring) press the  button.

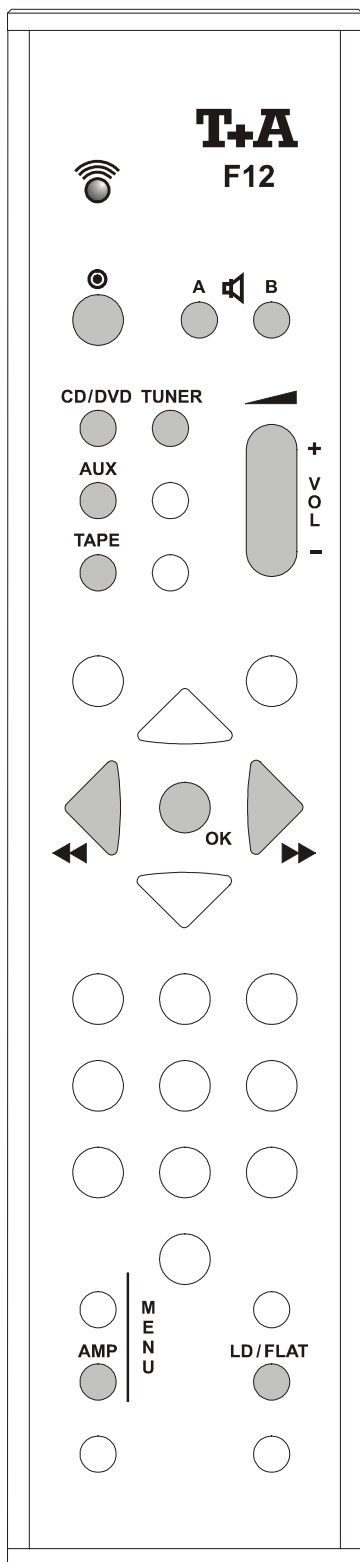

- Pressing the button repeatedly causes the screen to alternate between the auditioning source, e.g. **'TUNER'** and the recording machine **'TAPE'**. When set to **monitor mode**, the screen also shows the  symbol.
- About a second after the selected source device appears, the screen shows the standard machine-specific display for that auditioning source.

OPERATING THE AMPLIFIER BY REMOTE CONTROL





GENERAL INFORMATION

In the drawing of the remote control handset shown alongside the buttons marked "  " are those which are used to control the amplifier. None of the other buttons have any effect on the amplifier

	ON If the system is already switched on, the  button on the remote control handset switches the system to stand-by mode.
---	---

In stand-by mode the screen just shows the time of day. The time display indicates that the machine is able to respond to remote control signals. However, the power consumption of the system is reduced to less than 1 Watt in this mode. Pressing the  button on the handset a second time switches the system on again.





Notes:

- If the system is set to **single-room mode** (see *SETUP functions*), the machine reverts to the settings which were in use last time you listened to the system.
- If the system is set to **multi-room mode**, only the loudspeakers in the room where the user is located are switched on,  **A** in the main room, or  **B** in the secondary room. The volume is limited to "room level" when you initially switch on.

VOLUME CONTROL

<p>VOL -</p> <p>VOL +</p>	<p>Every time you press the VOLUME rocker the volume level is reduced (VOL -) or increased (VOL +) by 1.25 dB.</p> <p>If you hold the VOLUME rocker pressed in for more than one second, the volume alters continuously until you release the rocker again.</p> <p>Every time you alter the volume, the screen briefly displays the current value.</p>
---	---

SPEAKER OUTPUTS

<p>A </p> <p>B </p>	<p>This button switches the speaker output  A and/or  B on or off. If you press one of the buttons, the new status is shown briefly on the alpha-numeric screen, e.g.:</p> <p>'SP A ON' or 'SP A OFF'</p> <p>The current status of the loudspeaker outputs is also displayed continuously on the screen in the form of a letter 'A' or 'B'.</p>
<p>Note: When you switch the system on the speaker outputs are initially switched off. After a short standard delay period speaker output 'A' always switches itself on.</p>	

LOUDNESS / LOW BASS EQUALISATION

<p>LD / FLAT</p>	<p>Short keypress: Switches LOUDNESS On / Off.</p> <p>Long keypress (approx. 1 sec.): Switches low bass enhancement On / Off.</p>
-------------------------	---

SELECTING THE AUDITIONING SOURCE

You select the machine you want to listen to by pressing one of the source buttons. The signal from this source is then reproduced by the system.

At any one time you can only remote-control the machine which is currently selected as the auditioning source. The auditioning sources are selected using the following buttons on the remote control handset:

<p>CD / DVD</p>	internal CD player
<p>TUNER</p>	internal tuner
<p>AMP</p>	source device connected to the pre-amplifier input AUX/TV
<p>TAPE</p>	recording machine connected to the pre-amplifier input TAPE



Note:
When you switch sources the screen shows the newly selected auditioning source briefly. It then reverts to a standard machine-specific display.





AMPLIFIER SPECIAL FUNCTIONS

MENU CONTROL SYSTEM

The special functions menu contains those amplifier functions which cannot be accessed directly by their own buttons on the front panel. Instead they are accessed and controlled by a menu control system operated from the remote-control handset.

- Balance setting **(BALANCE)**
- Bass tone control **(BASS)**
- Treble tone control **(TREBLE)**
- Set-up functions **(SETUP)**
- Changing display brightness **(DIMMER)**
- Setting the time of day **(CLK)**
- Single-room / multi-room mode **(VOL A/B)**
- Changing AUX input sensitivity **(AUX)**

The menu system is controlled using the remote control **AMP**, , , and **OK**.

	<p>Opens the amplifiers special functions menu.</p> <p>Repeat pressing the button would display the menu points in next order.</p> <p>Menu point 1: 'BALANCE'</p> <p>Menu point 2: 'BASS'</p> <p>Menu point 3: 'TREBLE'</p> <p>Menu point 4: 'SETUP'</p>
 	<p>These buttons are used to make changes or make a selection within the individual menu points.</p>
	<p>This button activates the function shown on the screen. If you have made no change or selection in the function on the screen, this button terminates the special functions menu.</p>

Note:

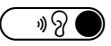
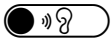
	<p>In use of the system handset F1 you can display the menu points by pressing  in next order. The button  displays the menu points in previous order.</p>
---	---

Menu point 1: **BALANCE**

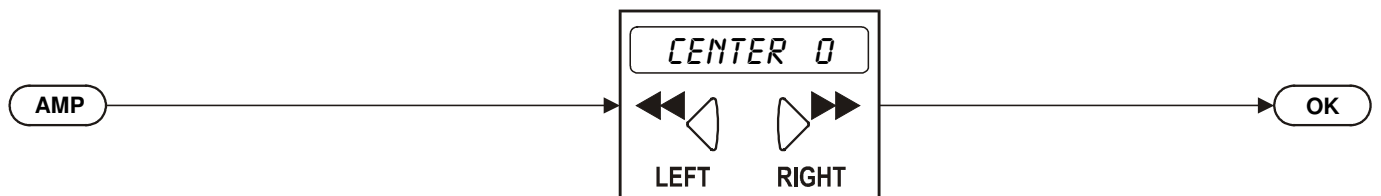

Introduction:

The '**BALANCE**' function is used to adjust the balance between the left and right channels, e.g. to compensate for non-symmetrical speaker positioning. The balance setting is infinitely variable.

Any change you make takes effect immediately. The function is terminated by pressing the **OK** button.

If none of the menu control buttons (**AMP**, **LEFT**, **RIGHT** or **OK**) are pressed for a period of about ten seconds, the unit interrupts the special functions menu and reverts to the standard display. (time-out)

Operation:

To change the balance setting press the remote control buttons in the sequence shown above. The screen then shows the pre-amplifier's current balance setting, e.g.:

'CENTER 0' = Stereo centre neutral

The balance setting can be adjusted to left or right in 31 steps. (**LEFT** or **RIGHT** button)

Possible adjustment range:

'BAL L 30' (stereo centre fully left)

to

'BAL R 30' (stereo centre fully right)

Note:

If the stereo centre is set to any value other than neutral, every time you alter the volume level the balance setting will appear briefly on the screen after the current volume value, e.g. **'VOL 27 L'**, which means that the stereo centre is offset to the (L)eft.

Menu point 2 + 3: **BASS + TREBLE**

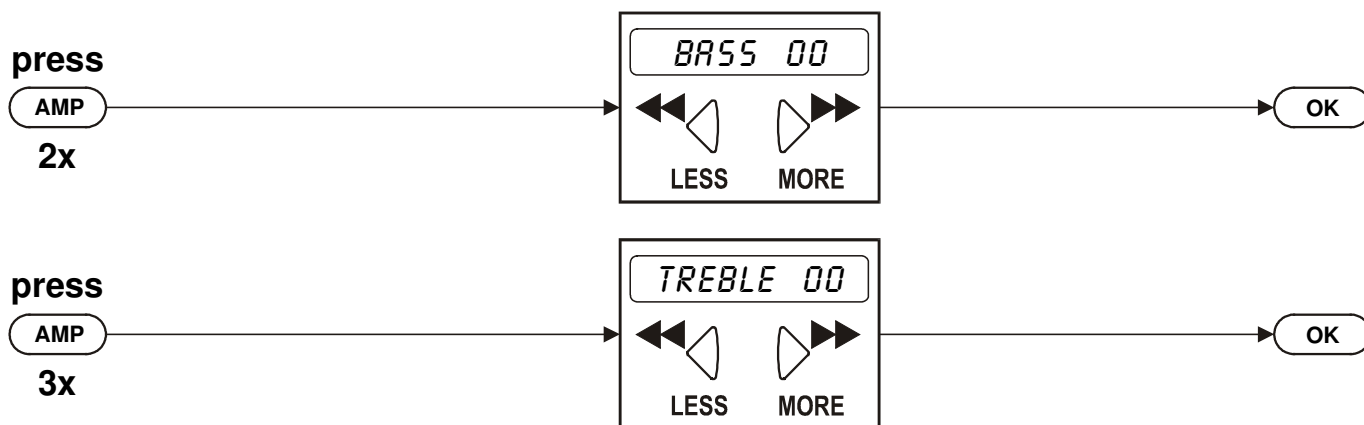

Introduction:

The system features active tone control facilities. The tone controls are designed to compensate for the negative effects of adverse loudspeaker positions or unusual conditions in the listening room.

Operation:

To change the tone settings press the remote control buttons in the sequence shown above.

The screen shows the current bass or treble setting for both stereo channels, e.g.:

'BASS +02' or 'TREBLE +04'

These settings can be altered over the range

- 14 dB (less bass / treble)

to

+14 dB (more bass / treble)

(**◀◀** or **▶▶**-button)

Any change you make takes effect immediately. The function is terminated by pressing the **OK** button.

If none of the menu control buttons (**AMP**, **◀◀** / **▶▶** or **OK**) are pressed for a period of about ten seconds, the unit interrupts the special functions menu and reverts to the standard display. (time-out)

Menu point 4: **SETUP**

Menu point 4 (**SETUP**) contains the following set-up functions, which are only rarely required:

SETUP function 1: '**DIMMER**'

SETUP function 2: '**12-15 CLK**'

SETUP function 3: '**VOL A/B**'

SETUP function 4: '**AUX**'

The diagram below shows the integration of the set-up functions into the amplifier special functions.

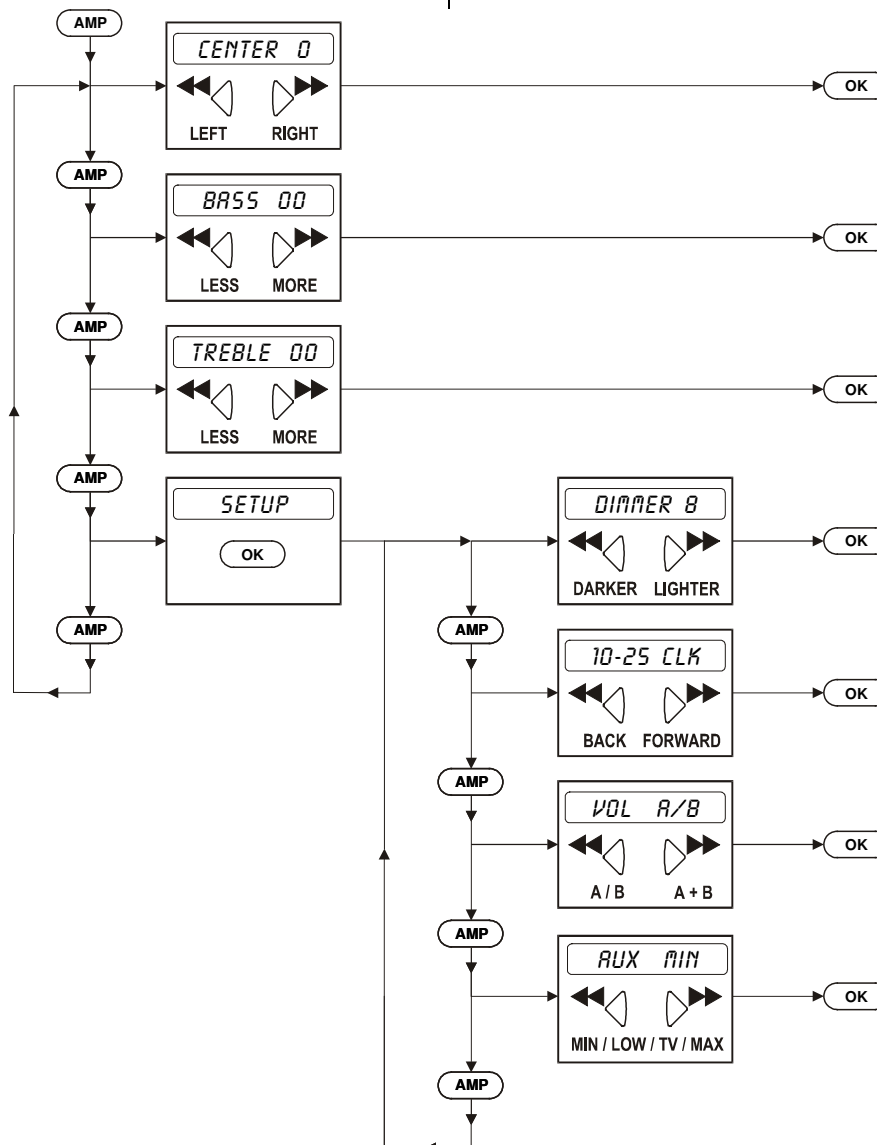

Menu point 4: **SETUP** - SETUP function 1: **DIMMER**



Introduction:

The brightness of the screen on the front panel can be set to any of eight levels (1..8):

'DIMMER 1' = darkest level

:

'DIMMER 8' = brightest level

This facility allows you to adjust the screen to suit the lighting conditions in your listening room.

Operation:

To alter screen brightness press the remote control buttons in the sequence shown above.

The screen then shows the current brightness level (e.g. 3):

'DIMMER 3'

You can change the current setting by pressing the remote control buttons ◀◀◀ or ▶▶▶.

Any change you make takes effect immediately. The function is terminated by pressing the **OK** button.

If none of the menu control buttons (**AMP**, ◀◀◀ / ▶▶▶ or **OK**) are pressed for a period of about ten seconds, the unit interrupts the special functions menu and reverts to the standard display. (time-out)

Menu point 4: **SETUP** - SETUP function 2: **SETTING THE CLOCK**

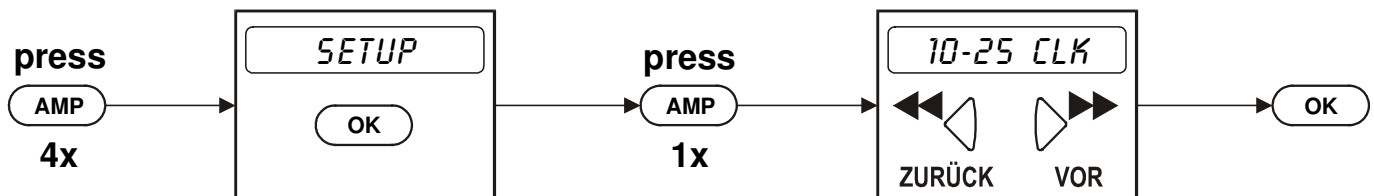

Introduction:

The presence of the integral clock allows you to set the machine to switch itself on automatically at a pre-programmed time. To use this facility you must first set the clock to the correct time.

Operation:

You can change the set time by pressing the remote control buttons in the sequence shown above. The screen shows the time of day which is currently set, e.g.

'10-25 CLK'.

You can change the set time by pressing the remote control buttons **◀◀◀** or **▶▶▶**; when you start doing this, the word **'CLK'** starts to flash.

The time alters at three different speeds, depending on the length of time you hold the buttons pressed in.

Once you have set the time correctly, press the **OK** button to store it. The screen shows **'SET'** instead of **'CLK'** for one second, e.g.: **'10-25 SET'**

If none of the menu control buttons (**AMP**, **◀◀◀ / ▶▶▶** or **OK**) are pressed for a period of about ten seconds (or, after changing the clock setting, for 90 seconds), the unit interrupts the special functions menu and reverts to the standard display. (time-out)

Menu point 4: **SETUP** - SETUP function 3: **SEPARATE VOLUME ADJUSTMENT**

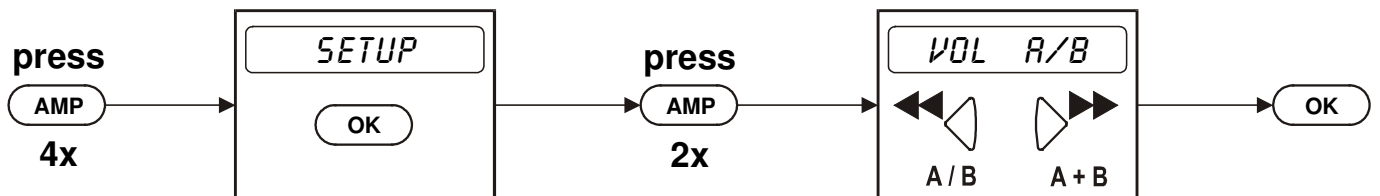

Introduction:

In normal the volume of the speaker output **A** and **B** are controlled in common.

If you connect an additional remote control receiver and a pair of loudspeakers to the speaker connections **B** (preferably in a different living room), it is possible to adjust the volume separately for the pairs of speakers **A** and **B**.

If the system is set to **multi-room mode**, only the loudspeakers in the room where the user is located are switched on; the other speakers keep quiet.

The volume for **A** can only be altered using the **VOLUME** buttons on the machine's front panel, or via the integral remote control receiver.

The volume for **B** can only be adjusted via an external remote control receiver (*see also "multi-room sound system" in the chapter CONNECTING THE SYSTEM, THE SYSTEM IN USE*).

Operation:

To alter the option press the remote control buttons in the sequence shown above. The screen shows the current setting, e.g.

'VOL A/B' separate volume adjustment
(multi room sound system)

or

'VOL A+B' common volume adjustment
(single room sound system)

You can select the option with the **◀◀** or **▶▶** button.

The function is terminated by pressing the **OK** button.

If none of the menu control buttons (**AMP**, **◀◀** / **▶▶** or **OK**) are pressed for a period of about ten seconds, the unit interrupts the special functions menu and reverts to the standard display. (time-out)

Menu point 4: **SETUP** - SETUP function 4: **INPUT SENSITIVITY AUX/TV**

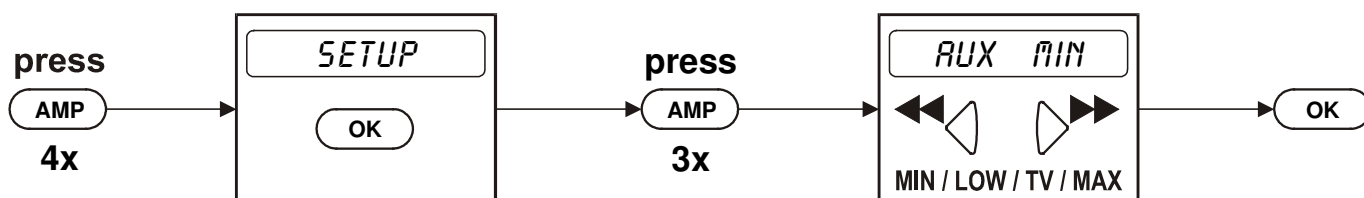

Introduction:

The sensitivity of the **AUX/TV** input can be changed to any of four settings so that you can continue to use source devices which are quieter than normal without suffering a disturbing change in volume when you switch from one source to another:

- 'AUX MIN'
- 'AUX LOW'
- 'AUX TV'
- 'AUX MAX'

The volume corresponds to the setting you choose, i.e. it is quietest at the '**MIN**' setting and loudest at the '**MAX**' setting.

Note:

To avoid overloading the input sensitivity should be set to '**MIN**'.when a high level source is connected to the **AUX/TV** input.

Operation:

To alter input sensitivity of the **AUX/TV** input press the remote control buttons in the sequence shown above.

The screen then shows the current brightness level e.g.:

'AUX MIN'

You can change the current setting by pressing the remote control buttons ◀◀ or ▶▶. Any change you make takes effect immediately.

If none of the menu control buttons (AMP, ◀◀ / ▶▶ or OK) are pressed for a period of about ten seconds, the unit interrupts the special functions menu and reverts to the standard display. (time-out)

OPERATING THE TUNER

PRESET SELECTION

When you want to listen to the tuner you must first select it as the current auditioning source. This is done by pressing the  button repeatedly until the word 'TUNER' appears on the screen.

The system can store a total of 60 station presets. The preset stores the frequency together with the other tuner settings (**MONO / STEREO, ATTENUATOR** etc.) (see Chapter "Storing and erasing presets"). When you call up a preset the tuner reverts to the exact setting in which the preset was stored.

Pressing the  button briefly calls up the next stored tuner preset (in ascending order). If you hold the button pressed in for longer than one second, the tuner jumps back to the preceding preset.

If you continue to hold the  button pressed in, the tuner continuously jumps back to the previous preset number until you release the button. Empty memory spots are automatically skipped.

Note:

If you select a preset and the new station is broadcasting RDS information, the screen displays the station's name. Otherwise the screen shows the new preset number and the reception frequency. After about a second the preset number is replaced by a tuning indicator.

TUNER DISPLAY ELEMENTS

STEREO INDICATOR

This symbol lights up if the station you have selected is broadcasting a stereo signal.

The indicator does not light up if the transmission is in mono, or if the tuner has been set manually to MONO reception mode - 'RCVM MONO' (see *Tuner special functions*).

SIGNAL STRENGTH INDICATOR

This symbol helps you to judge the signal strength and the quality of reception you can expect from the selected station. If the symbol lights up, hiss-free MONO reception is available. The stereo signal may have slight background hiss.

Note:

The tuner is fitted with an **automatic High Blend circuit**. When a stereo signal of inadequate field strength is picked up, this circuit reduces the base width of the stereo signal and thereby reduces the background hiss.

TIMER

The system incorporates an integral clock module which can be set to switch the machine on automatically at a fixed time of day. For this to work properly you have to set the internal clock to the correct time of day, and then set the power-on time. The time of day is set in the special function 'SETUP' (see the Chapter "Menu control system").

If you want to switch the timer on and off you must first select the tuner as the current auditioning source. This is because the timer always switches the system on set to the auditioning source TUNER, as this is the only way to ensure that a source signal is always present when the timer is tripped.

PROGRAMMING THE TIMER

First select the **TUNER** as auditioning source. Select the station and set the volume at which you want the machine to switch itself on.

Pressing the  button now switches the machine to Timer Set mode.

If you have already selected a power-on time, the time you have set appears on the screen: e.g. '14-38 TIM', with 'TIM' (TIMER) flashing.

You can now move the time setting forward or back using the **VOLUME** buttons. If you hold the buttons pressed in, the rate of change increases.

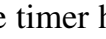
To activate the timer hold the  button pressed in for about a second. The screen briefly shows the switch-on time and 'SET' instead of 'TIM', e.g. '14-38 SET'.

At the same time the screen indicates that the timer is active by showing the glowing  symbol.

Pressing the  button again cancels the timer. The screen confirms this by showing the message 'ALARM OFF' briefly.

If you now switch the machine to STAND-BY mode when the timer has been set to active (by pressing the  button at the front of the unit or on the RC handset), then it will switch itself on again at the programmed time.

Important:

The integral timer can only switch the machine on from STAND-BY mode. When in STAND-BY mode the machine's screen shows the time of day.

When in STAND-BY mode the machine can temporarily show the alarm time if you press the  button (no longer glowing).

A longer press (about 1 second) with the machine in STAND-BY mode cancels the timer, and the screen confirms your action by displaying the message: 'ALARM OFF'.

ALARM - with automatic power-off

When the unit switches itself on under timer control, the illuminated  symbol flashes. This indicates that the timer will automatically switch the unit back to STAND-BY mode after about one hour.

If you operate any control on the unit during this one-hour period (e.g. you alter the volume level or change pre-sets), then the illuminated  symbol stops flashing. The timer will now **no longer switch off automatically** after an hour. If you wish to switch it off, you must do so manually!

OPERATING THE TUNER BY REMOTE CONTROL

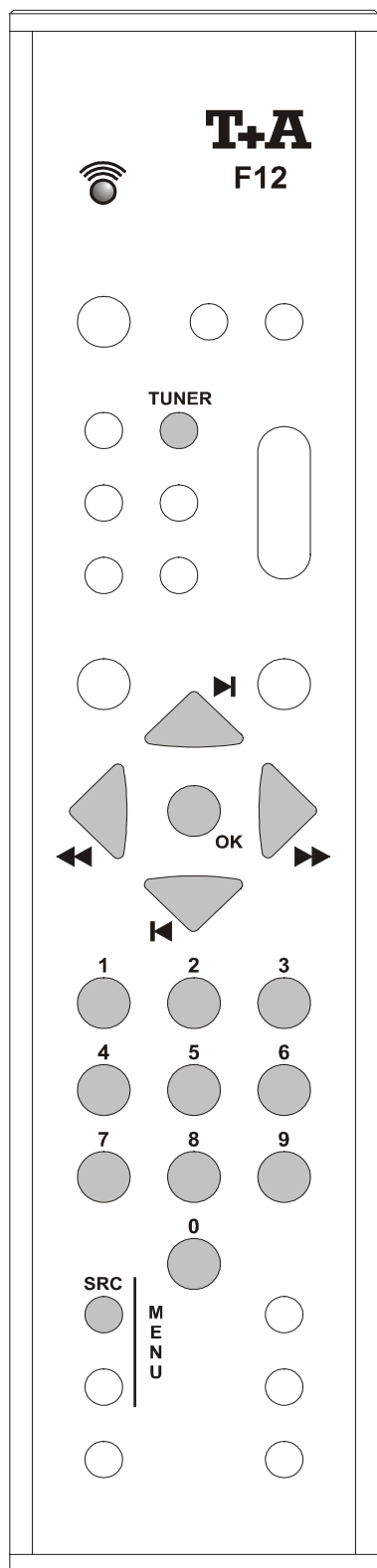

GENERAL INFORMATION

The tuning button on the machine's front panel provides only limited control of the tuner. The remote control handset provides full control in the most convenient manner.









To be able to remote-control the tuner the **F12** remote control handset must be set to **HiFi** operation and the tuner must be selected as the auditioning source. The handset only controls currently auditioning source.

In the drawing alongside the buttons marked "  " are those which are used to operate the tuner. None of the other buttons have any effect on the tuner.



SELECTING THE TUNER AS AUDITIONING SOURCE

TUNER	Selects the system's integral tuner as the current auditioning source. The screen briefly displays the word ' TUNER ', then reverts to the standard tuner screen. From now on all remote control commands are passed to the tuner.
--------------	---

SELECTING A PRESET AND STATION

	Calls up the preset with the next lower preset number; empty memory spots are automatically skipped.
	Calls up the preset with the next higher preset number; empty memory spots are automatically skipped.
	Pressing this button briefly drops the reception frequency of the tuner by a 25 kHz step
	Pressing this button briefly raises the reception frequency of the tuner by a 25 kHz step.
Note:	<p>If one of the tuning buttons ( or ) is held pressed in for about a second, the tuner starts a station search in the corresponding direction (down or up). It stops automatically at the next station broadcasting an adequate signal, and then tunes it in accurately.</p> <p>If you now release the tuning button, the machine stays tuned to that station. If you continue to hold the button pressed in, then the machine resumes the search after about a second. You can interrupt the search process at any time by pressing the opposite tuning button. At this point a short press of any preset button ( or ) activates the last preset you used.</p>

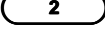
NUMERIC PRESET SELECTION

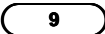
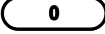
    	<h3>NUMERIC BUTTONS</h3> <p>Numeric input for direct selection of a preset.</p>
Note:	<p>When you press one of the numeric buttons the screen shows the letter 'P' for PRESET together with the number you just pressed.</p> <p>The system now waits for about 2 seconds; if within that time you press a second numeric button, then it is assumed to be the second digit of the preset number.</p> <p>If you do not press a second button, the machine assumes that you have selected a preset with a single-digit number. The preset is activated when you enter the second number, or when the two-second waiting period has elapsed.</p> <p>The machine ignores invalid preset numbers (lower than 01 or higher than 60); the display shows: 'Pxx ERROR'.</p> <p>Empty Presets are also ignored and displayed as : 'Pxx - - - -'.</p>

SWITCHING RADIOTEXT ON / OFF

TUNER	<p>Pressing this button briefly switches the radiotext display on and off for the station currently selected.</p> <p>When first switched on the machine's screen displays</p> <p style="text-align: center;">'RADIOTEXT'</p> <p>until a new message is displayed. If no radiotext is received for the selected station, the screen shows the message</p> <p style="text-align: center;">'NO RTEXT'</p> <p>for about one second, and then resumes the normal display. When the radiotext function is switched off, the screen shows the message</p> <p style="text-align: center;">'NO RTEXT'.</p> <p>If you switch to a new station the radiotext display is automatically halted; if you wish to see it again you must switch it on by pressing the TUNER button once more.</p>
--------------	--

DISPLAYING PRESET NUMBERS AND RECEPTION FREQUENCY





OK	<p>Pressing this button briefly replaces the RDS station name on the screen with the current preset number, together with the associated station frequency. This information stays on the screen for about two seconds.</p>
-----------	---





TUNER SPECIAL FUNCTIONS

MENU CONTROL SYSTEM



The special functions menu contains the tuner functions which cannot be accessed by their own buttons on the front panel. Instead they are controlled via a remote-control menu system:

- Changing the reception mode (ReCeiveMode) (RCVM)
- Storing and erasing presets (PRESET)

The menu system is operated using the remote control buttons , ,  and .

	<p>This button opens a menu offering two tuner special functions.</p> <p>Repeat pressing the button would display the menu points in next order.</p> <p>Menu point 1. 'RCVM'</p> <p>Menu point 2. 'PRESET'</p>
 	<p>These buttons are used to make a selection or perform any changes within the menu points.</p>
	<p>Activates the function shown on the screen. If you have made no change or selection in the function on the screen, pressing  terminates the tuner special functions menu.</p>

Note:

	<p>In use of the system handset F1 you can display the menu points by pressing  in next order. The button  displays the menu points in previous order.</p>
---	---

Menu point 1: **RCVM**

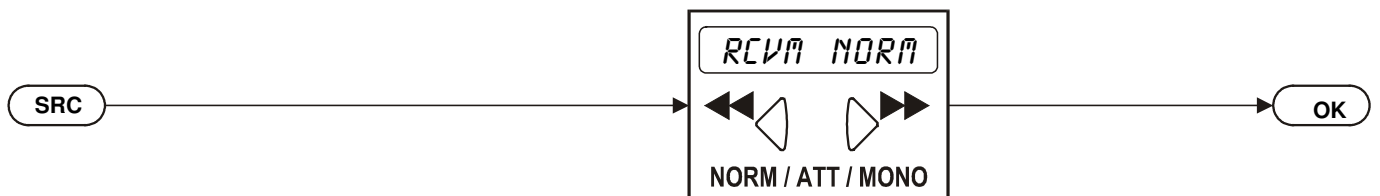

Introduction:

The tuner can be set to any of three different reception modes (ReCeiveMode = RCVM).

Reception mode	Screen display:
normal STEREO	RCVM NORM
normal STEREO with aerial attenuator	RCVM ATT
MONO	RCVM MONO

The standard tuner setting is STEREO (**RCVM NORM**). In this mode the tuner suppresses interference from adjacent stations, providing outstandingly good reproduction quality even under difficult reception conditions.

If you try to receive stations close to an unusually powerful local station you may encounter intermodulation effects (whistling and twittering "birdie" noises).

In this type of case we recommend that you switch on the aerial attenuator; the message '**RCVM ATT**' then appears on the screen.

Very weak or very distant stations can usually only be picked up with serious background hiss, and in this case you should switch to MONO reception, as this reduces the hiss significantly.



Selecting the reception mode '**RCVM MONO**' automatically reduces the search threshold. The automatic station search function now also stops at distant, weak and slightly "hissy" stations.

Operation:

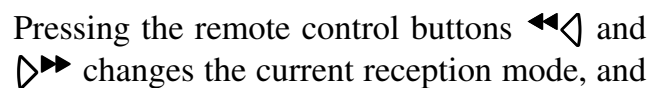
To change the reception mode press the remote control buttons in the sequence shown above.

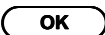
Pressing the remote control buttons  changes the current reception mode, and the new mode then appears on the screen.

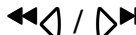
Any change you make takes effect immediately. The function is terminated by pressing the  button.

If none of the menu control buttons (,  or ) are pressed for a period of about ten seconds, the unit interrupts the special functions menu and reverts to the standard display. (time-out).

Menu point 2: **PRESET** - PRESET function 1: **STORING PRESETS MANUALLY**

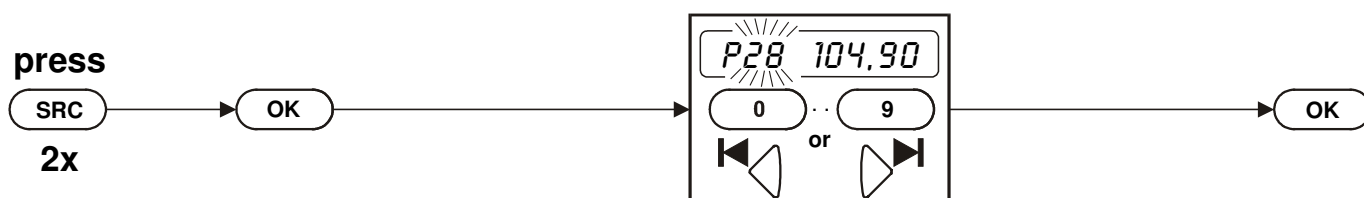

Introduction:

The tuner can store a total of 60 station settings (presets). The preset stores the frequency and the reception mode, and also the RDS station name - provided that it was picked up in full at the time it was stored.

When you call up a preset the tuner reverts to the exact setting in which the preset was stored.

Operation:

Before you store a preset the station must first be tuned in accurately; you may have to wait until the complete RDS station name appears on the screen. Then you should press the remote control buttons in the sequence shown above.

The screen shows a 'P' on the left followed by a flashing number, with the station frequency after that, e.g.:

'P28 104.90' MHz

The flashing number is the preset number under which the current station will be stored.

You can change the preset number using the and buttons, or you can enter the number you want to use directly using the numeric buttons.

To store the setting under the current pre-set number you must press the **OK** button. The screen then shows the message 'STORE' for a brief period instead of the frequency. The pre-set is now stored, and the **MANUAL STORE** process is ended.

If none of the menu control buttons (**SRC**, / or **OK**) are pressed for a period of about ten seconds, the unit interrupts the special functions menu and reverts to the standard display. (time-out)

Note:

If you attempt to store an invalid preset number (xx), the machine responds with an error message on the screen: '**Pxx ERROR**'; the tuner then terminates the special functions menu.

The RDS norms state that the station name must be broadcast in static form, but many stations present the information as a moving script. If this occurs, do not store the preset until the transmitter broadcasts its station name constantly for a fairly stable period.

Menu point 2: **PRESET** - PRESET function 2: **AUTOMATIC PRESET STORING (AUTOSTORE)**

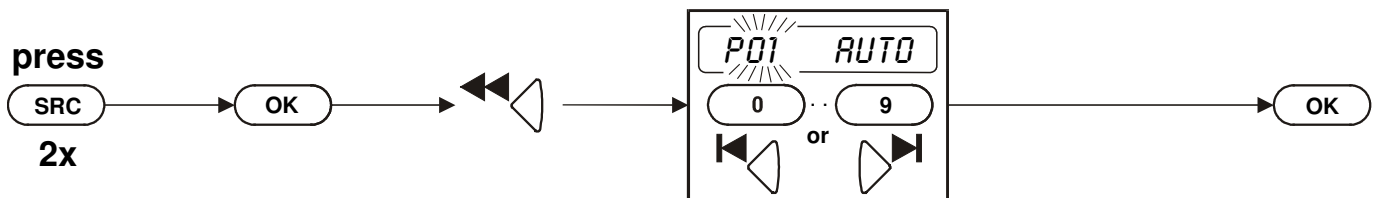

Introduction:

If you select automatic preset storing, the tuner automatically searches the whole VHF band twice (using different search thresholds) for stations which can be received well in STEREO mode, and automatically stores the stations it finds.

This process can take some time, as the tuner attempts to receive the complete RDS station name for each station it finds, so that the name can be stored in the preset.

If the **AUTOSTORE** function does not pick up the RDS station name, but at a later date the tuner is able to receive it when you are tuned to that preset, then the station name appears on the screen and is automatically stored with the preset.

Operation:

To use the **AUTOSTORE** function press the remote control buttons in the sequence shown above.

As with the manual preset storing procedure you can use the and buttons or the numeric buttons to select a preset number as the starting point, i.e. the stations the system locates will be stored after that number.

If you want to store the station information starting at the beginning, then you should select the number 01.

If none of the menu control buttons (, / or) are pressed for a period of about ten seconds, the unit interrupts the special functions menu and reverts to the standard display. (time-out)

Pressing the button now activates the **AUTOSTORE** function, and the frequency display starts to rise incrementally.

You can interrupt the PRESET function **AUTOSTORE** by pressing the ◀◀ or ▶▶ button.

When the tuner has searched the whole VHF band, or when the final memory spot is full, the tuner ends the **AUTOSTORE** function and terminates the special functions menu.

Note:

The tuner is not capable of assessing the quality of each individual station, so it provides the user with a means of editing the presets manually.

The same facility is useful if you find that stations have been stored whose **RDS** station name was not recognised in full by the **AUTOSTORE** function, or that a station failed to broadcast its RDS name in accordance with the RDS norms.

To edit the presets you call up each one in turn and attempt to optimise reception quality by changing the reception mode

(NORM / ATTENUATOR / MONO);

finally you store the preset again manually (*see Manual storing of presets*).

Presets which contain stations of such low quality that they are not worth listening to, or which contain a duplicate station on a different frequency, should simply be erased (*see Erasing A Preset*).

If you repeat the **AUTOSTORE** process, the machine will not store the same stations twice, i.e. frequencies already stored will not be stored again.

Menu point 2: **PRESET** - PRESET function 3: **ERASING A PRESET**

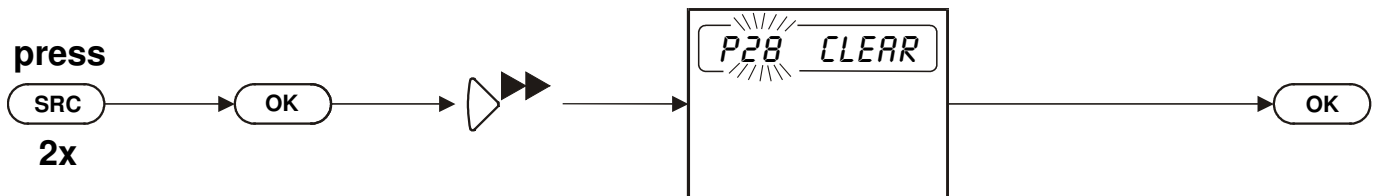

Introduction:

Presets which contain stations of such low quality that they are not worth listening to, or which contain a duplicate station on a different frequency, should simply be erased.

Under certain circumstances, e.g. after a house-move, you may find it necessary to erase all the pre-sets. In this case please read the section entitled '*Tuner section*' in the '*Trouble Shooting*' Chapter.

Operating:

First call up the preset to be erased, either by entering the number directly or using the / buttons, then press the remote control buttons in the sequence shown above.

The selected preset is shown in the display as follows:

'P28 CLEAR'

If none of the menu control buttons (, / or) are pressed for a period of about ten seconds, the unit interrupts the special functions menu and reverts to the standard display. (time-out)





Pressing the button erases the preset and terminates the special functions menu.

Note:

If you attempt to store an invalid preset number (xx), the machine responds with an error message on the screen: '**Pxx ERROR**'; the tuner then terminates the special functions menu.

OPERATING THE CD PLAYER

To play a CD:

- Open the CD drawer
( /  button)
- Place a CD in the drawer, printed face up.
- Close the CD drawer
( /  button)

Note:

Closing the drawer with CD inserted causes the **K1** to automatically select CD mode.



Immediately the drawer is closed the machine reads the disc's "Table of Contents"; at this point the screen shows '**READING**'. During this period the machine ignores all button presses. The screen then shows the current operating status and the total number of tracks on the CD in the machine, e.g.: '**STOP 16**'.



- Start the play process ( button)
Playback begins, and the screen shows the operating status and the number of the track currently playing: i.e. : '**PLAY 01**'.

The CD stops at the end of the last track and the screen again shows 'STOP' and the total number of tracks on the CD.



Variations:

If you press the ( button after inserting the CD, the drawer closes and the playback process starts automatically with the first track.

You can interrupt playback temporarily at any time by pressing the ( button. During the interruption the screen shows '**PAUSE**'. Press the ( button a second time to resume playback.

If you press the ( button during playback, the player jumps to the start of the next track. A long press (about 1 second) on the ( button during playback causes the player to jump to the start of the previous track. If the button is held pressed in, the machine jumps back repeatedly until you release the button.

The screen displays the word '**JUMP**' while it is jumping to the next or preceding track.

Pressing the ( /  button ends the playback process, and the screen shows: '**STOP**'.

Pressing the ( /  button again when the machine is in **STOP** mode opens the CD drawer.

Selecting a track during playback:

Press the ( button repeatedly, or hold it pressed in, until the number of the track you want to listen to appears on the screen after '**PLAY**'.

When you release the button the machine briefly interrupts playback, the screen shows '**JUMP**', and then the selected track is played.

Note:

You can also directly enter the number of the track you want to hear using the numeric buttons on the remote control handset.

OPERATING THE CD-PLAYER BY REMOTE CONTROL

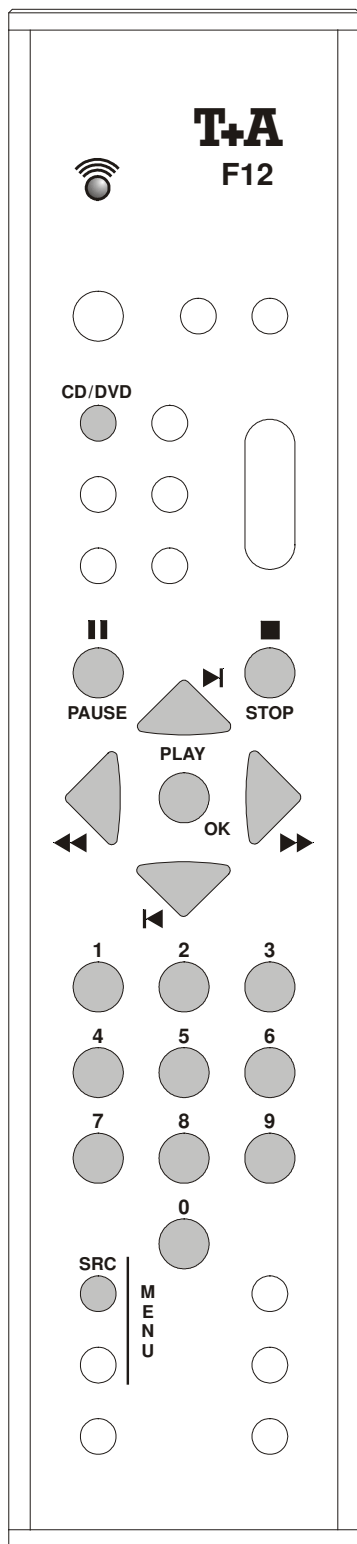

GENERAL INFORMATION

You can operate all the CD mechanism's facilities and all the system's special functions from the remote control handset, with the exception of opening and closing the CD drawer.









To be able to remote-control the CD player CD must be selected as the auditioning source. The handset only controls currently auditioning source.

In the drawing shown here the buttons marked ' 





SELECTING THE CD AS AUDITIONING SOURCE

CD / DVD	Selects the integral CD player as the current auditioning source. The letters 'CD' appear on the screen briefly, then the screen shows the standard display for the CD player. All remote control commands are now passed to the CD player.
-----------------	---

CONTROLLING THE CD MECHANISM

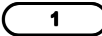
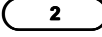
	Selects the previous track during playback.
	Starts CD playback, selects the next track during playback.
	Fast search backwards to locate a particular passage.
	Fast search forward to locate a particular passage.
Note:	After about two seconds the search speed rises. At the low search speed you can listen to the music, but at the higher speed the output is muted. During the search process the current track time is shown on the left of the screen. When the search reaches the start or end of the CD, the CD stops.
	Ends playback; the screen shows the message: 'STOP' .
	Interrupts playback, i.e. the current track is paused. The screen shows 'PAUSE' . A further brief press on the  button resumes playback. Pressing the  button in STOP mode starts PAUSE mode and causes a jump to the first track of the CD resp. the MEMO program
	Selects the playback mode (<i>see Menu control system</i>).

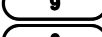
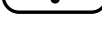
NUMERIC TRACK SELECTION

 	Direct numeric input for selecting a track number.
  	When you press a numeric button (e.g. 1) the screen shows: 'SELECT 1_.' For a period of 3 seconds a marker flashes. During this time you may: <ul style="list-style-type: none"> • press a second numeric button to complete a two-digit track number - the machine plays the selected track immediately. • If you do not press a second button and the 3-second period is over, the input assumed as a single-digit track number - the machine plays the selected track.
	Note: You can also enter a track number directly when the CD drawer is still open. In this case the drawer closes automatically and playback starts with the track you have selected. This button is used to store MEMO programs. If the menu control system is in use,  acts as the confirmation button (<i>see Menu control system</i>).

MEMO-PROGRAM

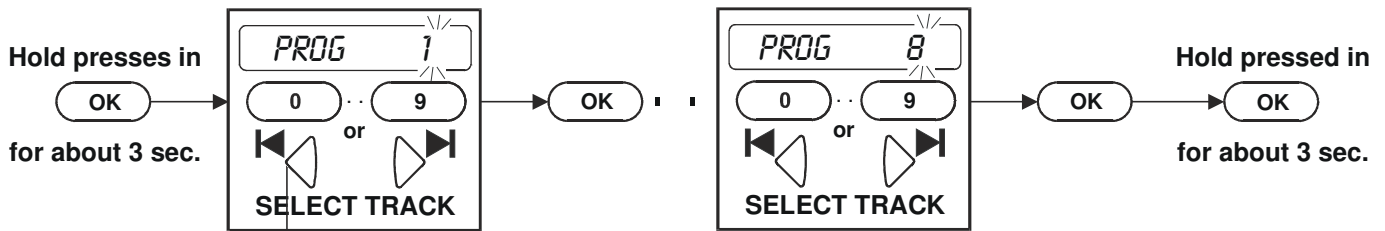

Introduction:



Each MEMO program can store up to twenty CD tracks in any sequence; it is useful, for example, when you are preparing to make a cassette recording. You can only produce a MEMO program for the CD actually in the drawer. The program is stored in the machine until you erase it again, or until you open the CD drawer.

Making a MEMO program:

Place a CD in the machine, and the screen displays the total number of tracks on the disc after the message 'STOP'.



- Activate the MEMO programming mode.
(hold the **OK** button pressed in for about 3 seconds)

The screen shows: 'PROG' and a number, which is a request for you to enter a track number.

- Hold the  or  button pressed in until the number of the track you wish to select appears on the screen after 'PROG'.
- Store the track in the MEMO program.
(press the **OK** button briefly)

The screen message 'PROG' flashes once to confirm that the track you have marked has now been accepted as the first track in the MEMO program. Select all the other tracks you wish to include in the same way, storing each by pressing the **OK** button again briefly.

Note:

Instead of using the  /  buttons the wanted track may be selected by pressing the numeric buttons. It can be stored by pressing the **OK** button as described above.

Once you have stored the 20th track the screen shows the message: 'FULL'. Please note: if you enter a further track, it will overwrite the 20th track, i.e. the last one you entered will be erased.

When you have stored all the tracks you wish to select, it only remains to terminate the MEMO programming process.

- End MEMO programming.
(hold the **OK** button pressed in for about 3 seconds)

The screen shows the message: 'STORED' and then displays in sequence all the track numbers of the MEMO program you have just produced, in the sequence in which you stored them.

Playing back a MEMO program:

The MEMO program can now be played back:

- Start the playback process (▶ button)

Playback begins with the first track of the MEMO program. While a MEMO program is being played back, the screen shows a letter 'P' before the current track number.

Pressing the buttons ◀▶ or ▶▶ selects the previous or next track in the usual way, but only within the MEMO program.

If you press the fast forward /fast back buttons (⏩ / ⏪) to select a track which is not included in the MEMO program, then the machine plays that track in full before reverting to the MEMO program.

Erasing a MEMO program:

Pressing the (■) / (▲) button when the machine is in STOP mode opens the CD drawer and erases the MEMO program.
(■ / ▲ button)

You can also erase a MEMO program without opening the CD drawer:



- Activate MEMO programming.
(hold the (OK) button pressed in for about 1 second)
- The screen shows: 'PROG' and a flashing number, requesting you to enter a track number.
- Erase the MEMO program.
(hold the (OK) button pressed in again for about 1 second)
- The screen shows the message: 'CLEAR', and the MEMO program is now erased.





CD PLAYER SPECIAL FUNCTIONS

MENU CONTROL SYSTEM



The special functions menu contains the CD player functions which cannot be accessed by their own buttons on the front panel. Instead they are operated by a remote-controlled menu system:

- PLAY A-B (PLAY AB)
- Selecting the screen mode (DIS TRACK / DIS TIME)
- Selecting the playback mode (REP OFF / REP ALL / REP TRACK / REP MIX)

The menu control system is operated using the remote control buttons **SRC**, ,  und **OK**.

	<p>Opens the menu with the three CD player special functions.</p> <p>Repeat pressing the button would display the menu points in next order.</p> <p>Menu point 1. 'PLAY AB'</p> <p>Menu point 2. 'DISPLAY'</p> <p>Menu point 3. 'REPEAT'</p>
 	<p>These buttons are used to make a change or a selection within the menu points.</p>
	<p>This button activates the function shown on the screen. If no change or selection was made in the function on the screen, pressing the button terminates the special functions menu.</p>

Note:

	<p>In use of the system handset F1 you can display the menu points by pressing  in next order. The button  displays the menu points in previous order.</p>
---	---

Menu point 1: **PLAY A-B**

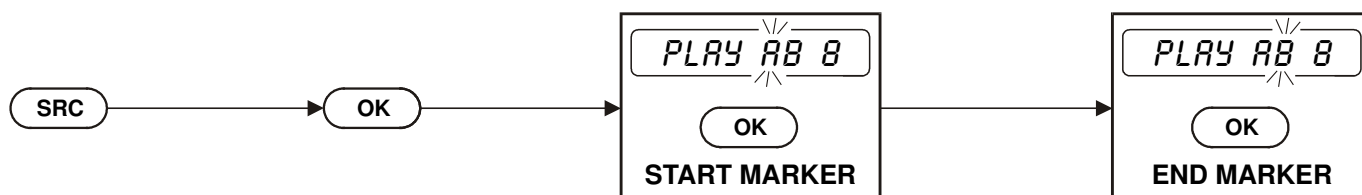

Introduction:

The PLAY A-B mode places two time markers **on the current CD**, and the machine then repeats the passage between the two markers constantly.

Operation:

First locate the starting point of the passage.
(◀◀ / ▶▶ or ◀ / ▶ buttons).

Press the remote control buttons in the sequence shown above.

If none of the menu control buttons (SRC, ◀◀ / ▶▶ or OK) are pressed for a period of about ten seconds after pressing OK button the first time, the unit interrupts the special functions menu and reverts to the standard display. (time-out)

The screen shows a flashing letter 'A' before the current track number, requesting you to enter the start marker:

'PLAY AB 08'.
↑ flashes

Set the start marker by pressing the OK button once.

After a short delay a flashing letter 'B' appears on the screen, requesting you to enter the end marker; press the OK button again at the end of the passage you want to hear repeated.

Once you have entered the end marker the screen shows: 'PLAY AB', and the player repeats the passage between the two markers constantly.

You can end the repetition at any time by pressing the STOP button. The machine then switches to STOP mode, and the screen shows the status message 'STOP'.

Variation:

Locate the start of the sequence to be repeated during the normal playback process, then press the PAUSE button. If you now activate the PLAY A-B point within the special functions menu (OK button), the CD will start automatically. You can now set the start and end markers by pressing the OK button again.

Note:

To find the beginning or endpoints you can use fast search backwards/forward buttons (◀◀ / ▶▶). Activating the **PLAY A-B** mode ends **REPEAT MIX** or **REPEAT TRACK** operation, and erases any existing **MEMO** program.

Menu point 2: **REPEAT / MIX-MODE / NORM-PLAY**

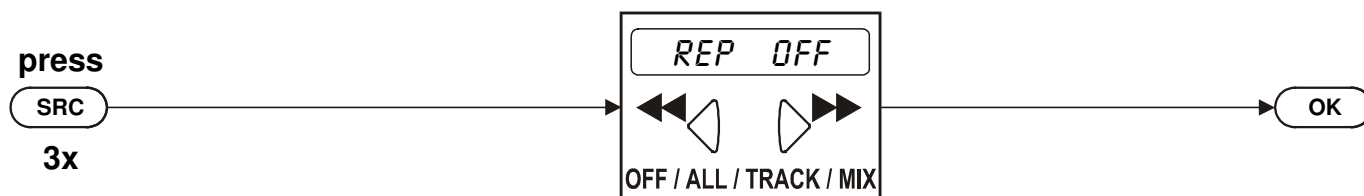

Introduction:

The system's integral CD player can play CDs in any of three different operating modes.

'REP OFF': Normal playback

'REP ALL': The tracks of the CD or of a MEMO program are repeated endlessly **in the order you have selected.**

'REP TRACK': The **current track** is repeated.

'REP MIX': The tracks of the CD or of a MEMO program are repeated constantly **in random order.**

Operation:

This menu point allows you to change the playback mode. Place the CD in the machine and then press the remote control buttons in the sequence shown above.

Press the ◀◀ or ▶▶ buttons repeatedly to cycle through the different playback modes on the screen:

'REP OFF'
'REP ALL'
'REP TRACK'
'REP MIX'

If none of the menu control buttons (SRC, ◀◀ / ▶▶ or OK) are pressed for a period of about ten seconds, the unit interrupts the special functions menu and reverts to the standard display. (time-out)

Pressing the OK button switches the machines to the playback mode shown on the screen.

If you open the CD drawer and close it again, the machine always reverts to normal playback mode (**REP OFF**).

Menu point 3: **DISPLAY**

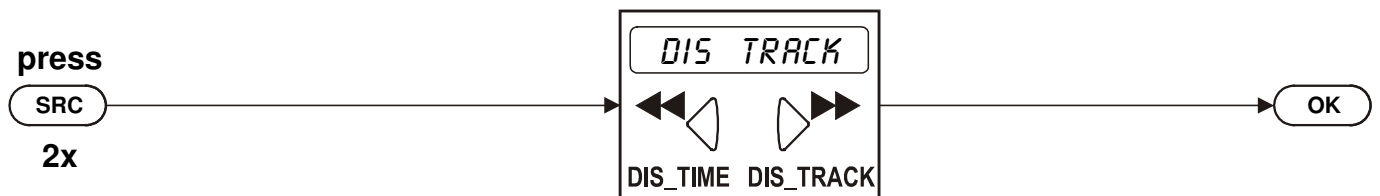

Introduction:



Most CDs contain several tracks. However, the tracks on some CDs can be very long, especially when they contain classical music.

To help you re-locate a particular passage within a long track, the system offers the facility to display the elapsed time of the current track in addition to the track number, in place of the operating status message **'PLAY'**.





Operation:

To switch the track play time display on or off press the remote control buttons in the sequence shown above. The screen then shows the message

'DIS TIME'.

Pressing the  or  button briefly alternates between the two display variants on the screen:

'DIS TIME' and **'DIS TRACK'**.

If none of the menu control buttons (,  /  or ) are pressed for a period of about ten seconds, the unit interrupts the special functions menu and reverts to the standard display. (time-out)

Press the  button to accept the current display option shown on the screen.

SAFETY NOTES

Please read through these operating instructions carefully before you attempt to use your new equipment. It includes important safety notes which must be observed!

1. This unit must be operated in dry conditions. It should be set up well out of reach of small children.
2. Protect the unit from drips and splashes of water; never place flower vases or fluid containers on the unit. Liquid or foreign bodies must never be allowed inside the machine. If a liquid or a foreign body gets inside the machine in spite of your best efforts, immediately disconnect the machine from the mains supply and take it to an authorised **T+A** specialist workshop for checking.
3. This machine should never be used without proper supervision. This applies to any electrical device.
4. If the machine is not to be used for a long period disconnect it from the mains supply at the wall socket.
5. Liquid or foreign bodies must never be allowed inside the case. Mains voltage is present inside the unit, and there is a risk of lethal electric shock.
6. The power supply required for this machine is printed on the mains supply socket. The unit must never be connected to a power supply which does not meet this specification.
7. Mains leads must be deployed in such a way that there is no danger of damage to them (e.g. through persons treading on them or from furniture).
8. Take particular care with plugs, distribution panels and connections at the amplifier. Never exert undue force on mains connectors.
9. The unit must be set up in such a way that none of the connections can be touched directly (especially by children).
10. With the exception of the connections and any other measures described in these instructions, no work of any kind may be carried out on the machine by unqualified persons.
11. The machine should only ever be opened by a qualified specialist technician. Repairs and fuse replacements should be entrusted to an authorised **T+A** specialist workshop.
12. If the unit is damaged, or if you suspect that it is not functioning correctly, immediately disconnect the mains plug at the wall socket, and ask an authorised **T+A** specialist workshop to check it.
13. Care of the machine
 - Always disconnect the unit from the mains supply before cleaning it.
 - The casing surfaces should be cleaned simply by wiping them with a soft, dry cloth.
 - Never use abrasive or solvent-based cleaners!
 - Before switching the unit on again check carefully that you have not disturbed any connections, and that no short-circuits exist at the terminals.

THE CONNECTION TERMINALS OF THE K1 CD-RECEIVER

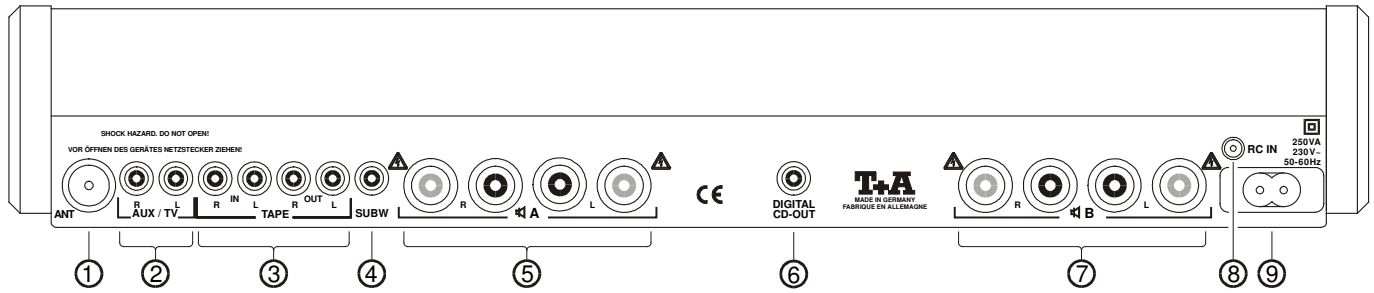

① ANT **AERIAL INPUT**

The system is fitted with a 75 Ω aerial input socket marked **ANT** which is designed to accept a standard domestic aerial. It also accepts a cable radio connection.

② INPUT AUX/TV

A general-purpose pre-amplifier input with an input resistance of 20 k Ω and a variable input sensitivity of 160 mV, 250 mV, 400 mV or 600 mV.

Note:

To avoid overload the AUX/TV input should be set minimum sensitivity 'MIN' (see *amplifier special function 'SETUP'*).

③ IN / OUT TAPE

Input / output sockets for connection to a machine with recording and playback facilities (recorder).

When you are connecting a recorder note that the **INPUT** sockets on the recorder must be connected to the **OUT** sockets on the system, and the **OUTPUT** sockets on the recorder to the **IN** sockets on the system.

④ SUBW

Output socket to connect an active subwoofer

⑤ A (Loudspeaker terminals)

Connect the main loudspeakers to this terminals. The impedance of each speaker must not be lower than 4 Ω .

⑥ DIGITAL CD-OUT

Digital output of the internal CD player for the use of coaxial digital leads.

⑦ B (Loudspeaker terminals)

Connect the loudspeakers located in the secondary room to the **B** terminals (Remote Speakers). The impedance of each speaker must not be lower than 4 Ω .

Note:

It is important to check that the terminal clamps are firmly screwed down, and that there is no chance of short-circuits due to projecting strands of wire.

Note:

If the loudspeakers are to be used in countries outside the EU the red/black stoppers can be removed from the loudspeaker terminals. The speakers can then be connected using banana plugs.

The stoppers are simply a push-fit in the terminals, and can be prised out from the rear using a suitable tool such as a knife blade.

⑧ RC-IN

Input socket for an **E 2000** remote control receiver, available as an optional accessory to suit multi-room operation.

⑨ MAINS INPUT

The mains cable is plugged into this socket. The system is designed to be used with a standard mains supply: 230 V / 50 – 60 Hz.

- The **K1** must not be connected to any other type of power supply.
- Mains leads must be deployed in such a way that there is no danger of damage to them (e.g. through persons treading on them or from furniture).
- If the machine is not to be used for a long period, disconnect it from the mains supply at the wall socket.

Loudspeaker and signal cables

The loudspeaker and signal cables (interconnects) used in the system do have an important influence on the reproduction quality of the system overall, and this should not be under-estimated. For this reason we at **T+A** recommend the use of high-quality cables and connectors.

Our accessory programme includes a range of excellent cables and connectors whose characteristics are matched to those of our loudspeakers and electronic components, and which therefore produce outstandingly harmonious results with them.

For difficult locations and constricted situations you will also find a range of special-length cables and non-standard connectors (e.g. right-angle versions) in the **T+A** accessory range. These items can be used to solve almost any connection and set-up problem you are likely to encounter.

Mains cables and mains filters

The mains power supply carries the essential energy to your system units, but it also tends to bear interference from remote devices such as radio and computer systems.

In order to prevent electro-magnetic interference reaching the audio system we recommend the use of the '**POWER BAR**' mains filter distribution panel from our accessory range.

This item often helps to bring a further improvement to the reproduction quality of our equipment.

For all your questions concerning cabling you will find your specialist **T+A** dealer competent and comprehensive in his advice, with no obligation to buy. We would also be glad to send you our extensive information material on this subject.

CONNECTING THE SYSTEM, THE SYSTEM IN USE

Unpack your **K1** carefully and keep the original packing in a safe place. The box and the packing materials have been specially designed for this unit and form a secure container for subsequent transport.

Read the safety notes included in these instructions and be sure to observe our recommendations when setting up the system.

If the unit is allowed to get very cold (e.g. during transport) then it is important to allow it to warm up to room temperature before switching on. This will ensure that any condensation inside the case has evaporated completely.

Before you set up the unit on a delicate painted or lacquered surface it is a good idea to check on a concealed area of the surface that it will not be damaged by the cabinet feet.

Set up the unit on a firm, level surface, and check that it is exactly horizontal. The unit should be well supported and stable.

The location must be thoroughly ventilated and dry, not subject to direct sunshine and away from the immediate vicinity of heaters. The unit must not be set up close to heat-producing, heat-sensitive or inflammable objects or equipment.

When setting up the equipment ensure that the flow of cooling air is unimpeded; the cooling slots must be left open and unobstructed.

There must be at least 5 cm free space on both sides of the system, and at least 15 cm free space above and behind it, so that the heat produced by the machine can disperse freely in the ambient air. If the unit is set up on a shelf or in a cupboard compartment, it must not be enclosed by doors. Any heat build-up may shorten the unit's effective life, and could be a source of danger.

Please be sure to switch off all units before you start wiring the components together.

The mains cable, the speaker should be kept as far away as possible from the interconnect cables (Cinch leads) and the aerial cable, otherwise there is a danger that quality of reproduction will be impaired.



We strongly recommend that you use the connecting leads supplied with the system exclusively.

The drawings on the following pages show how to connect all the components of your system together.

Connect the mains plug to the wall socket and switch the system on (press the  button on the machine's front panel).

The screen should now light up and the system is ready for use. Set the volume control to a very low level ( - button).

Switch to the auditioning source TUNER (press the  button on the RC handset).

If the radio aerial is connected and working properly, you can now search for a station using the station search procedure (hold the RC  or  pressed in for about 1 second).

The remote control receiver is located within the screen on the front panel.

For this reason it is important to set up the system in a position where there is direct line-of-sight contact between the remote control transmitter and the screen. Maximum range between transmitter and receiver is approximately 6 metres.

Check that the receiver is not subjected to direct sunlight and strong artificial lighting. Fluorescent and energy-saving lamps are particularly powerful sources of interference.

The sketch below shows the operating radius of the remote control system **F12**.

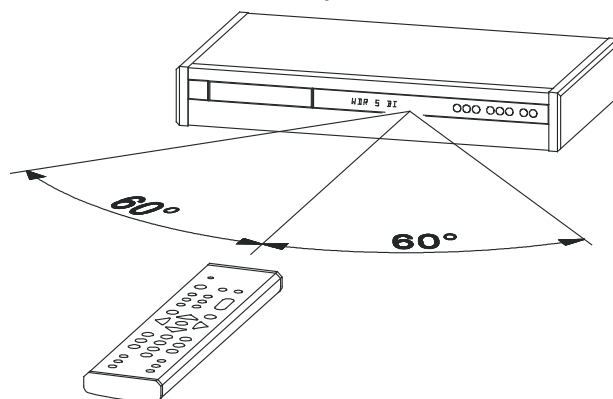

If you observe all our instructions the system should work correctly. If not, please read the section entitled **TROUBLE-SHOOTING**.

Use of banana plugs: see the section entitled '**Back panel connections**'.

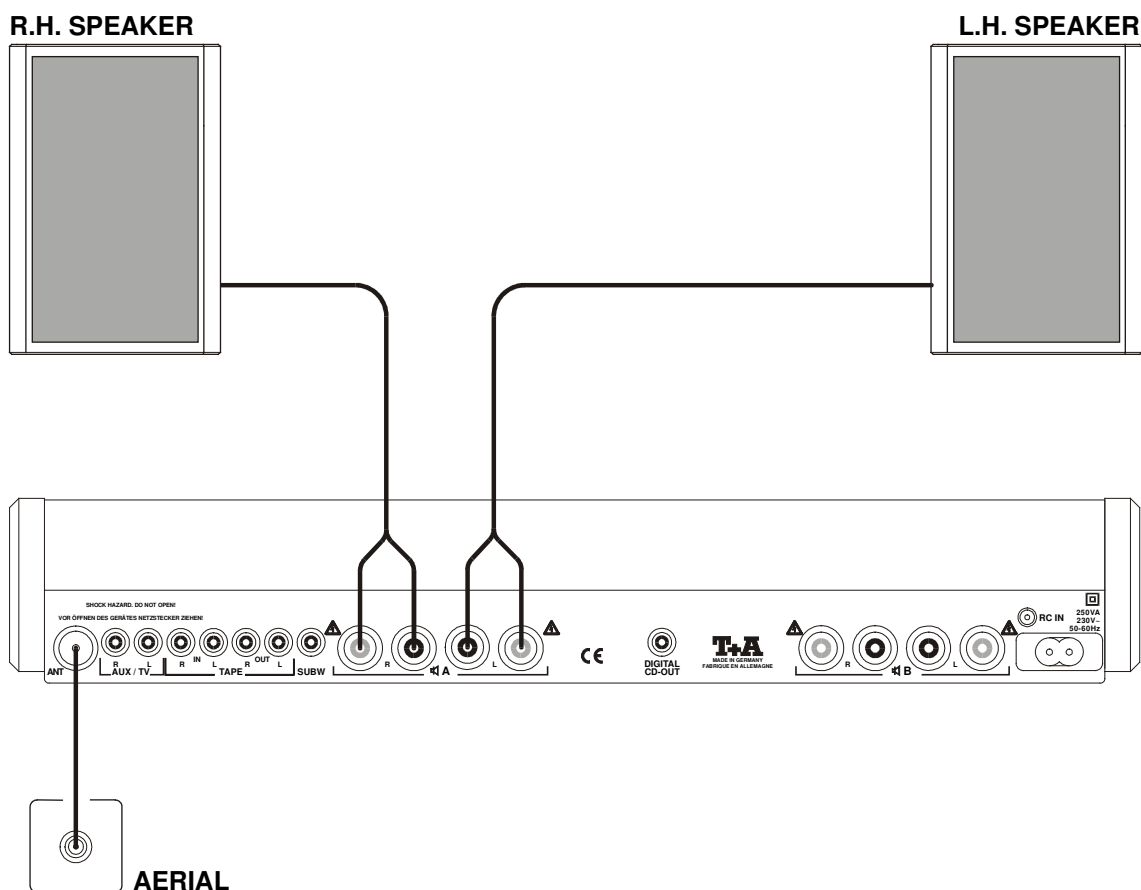

Multi-room sound system (MULTIROOM)

If you decide to use the **K1** as the basis of a sound system serving more than one room, we recommend the following configuration (see appropriate wiring diagram):

- The system is located in the main listening room (**Room A**). The speakers connected to the loudspeaker output **⏏ A** are in the same room.
- In the adjacent room (**Room B**) is a pair of speakers connected to the loudspeaker output **⏏ B**. If you want the facility to remote-control the system from **Room B**, you will need to install an **E 2000** remote control receiver in this second room, connected to the remote control input **RC IN** on the **K1**.
- The system needs to be set to '**VOL A/B**' mode (see *amplifier special function 'SETUP'*).
- If you switch on the **K1** next time using the remote control handset, only the loudspeakers in the user's room will be switched on; the other pair of speakers will stay silent. However, it is still possible to switch on in the usual way.
- If you stay in the neighbouring room you can only alter the volume in that room; from the main room you can only adjust the volume in the main room. These volume values are independent of each other over a broad range, but if the volume levels differ widely, a change in value in one room may affect the volume in the other.

Note:

The cable from the separate remote control receiver can be extended up to a total length of 50 metres.

If you need to extend the cable we recommend the use of twin-core screened cable with a conductor capacitance of 150 pF/m or less.

For greater cable lengths you will need to use lower capacitance cable.

You cannot access the **K1** system menus from the secondary room.

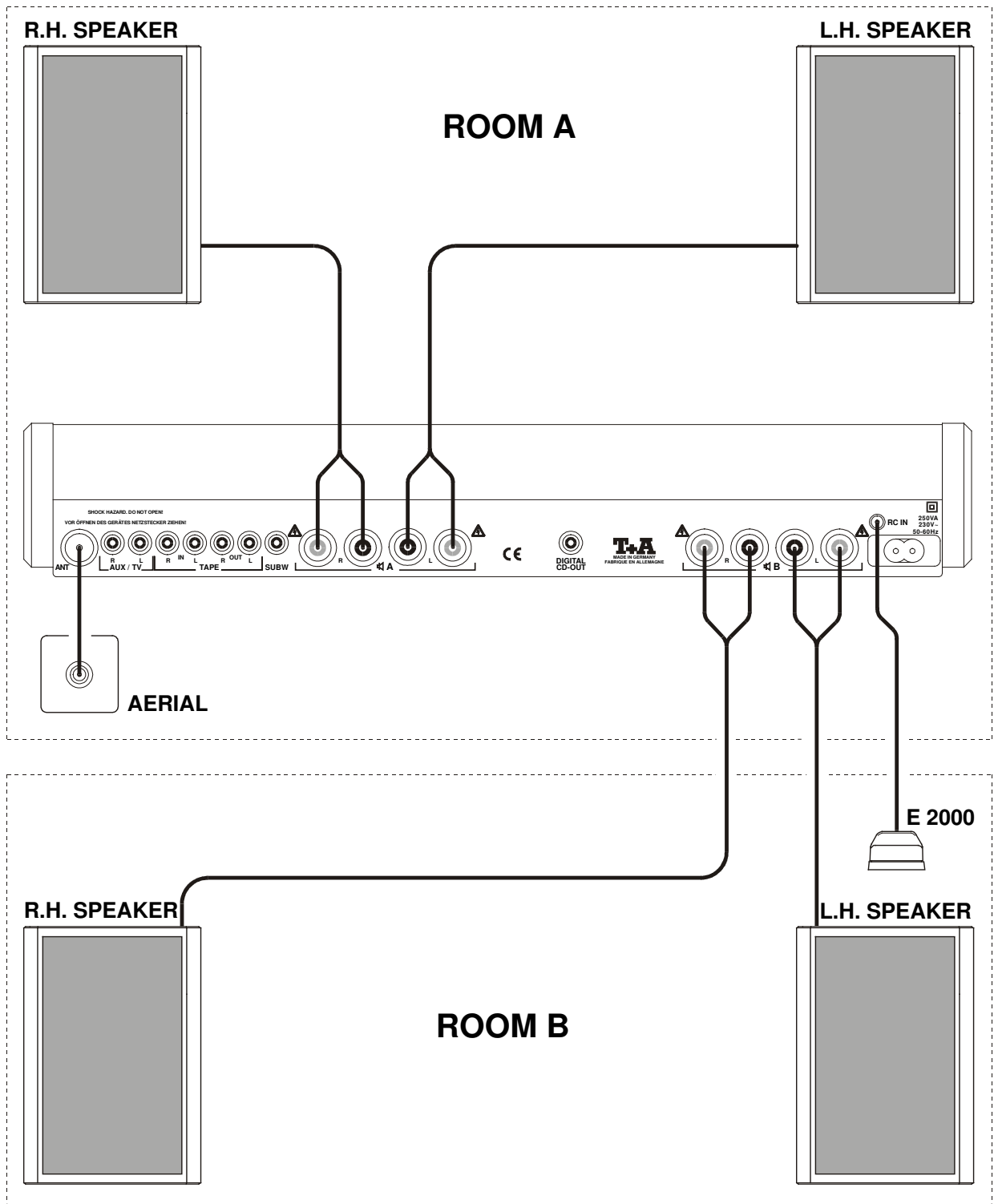

Wiring arrangement for the K1 CD-RECEIVER in a multi-room system

SPECIFICATION

AMPLIFIER SECTION

Input sensitivity	
AUX/TV	250 mV ... 850 mV (variable)
TAPE IN	600 mV
Outputs	
TAPE OUT	600 mV / 150 Ω
Nominal output per channel \sphericalangle A	4 Ω = 60 Watts 8 Ω = 45 Watts
Peak output per channel \sphericalangle A	4 Ω = 100 Watts 8 Ω = 70 Watts
Nominal output per channel \sphericalangle B	4 Ω = 60 Watts 8 Ω = 45 Watts
Peak output per channel \sphericalangle B	4 Ω = 100 Watts 8 Ω = 70 Watts
Total harmonic distortion	< 0,02 %

TUNER SECTION

FM reception range	87,5 - 108 MHz
Input stage	Dual-Gate MOS-FET, regulated
Sensitivity mono, S/N = 26 dB	0,9 μ V
stereo, S/N = 46 dB	33,0 μ V
Overload margin	> 110 dB
Tuned tuner circuits	4x Quarz PLL, digital
Selectivity (f = 300 kHz)	70 dB
Stereo crosstalk attenuation (1 kHz)	> 40 dB
MPX filter	19 kHz and 38 kHz
Pilot tone suppression	> 80 dB
Total harmonic distortion	< 0,1 %
Signal / noise ratio (IEC)	
Mono / Stereo	> 73 dB / > 68 dB
Frequency response +/- 1,5 dB	10 Hz ... 15 kHz
RDS display	Station name (program service), Radiotext

CD PLAYER

Mechanism	Precision mechanism, LDGU-Optics, semi conductor laser 780 nm / 2 mW
Wow and flutter	Quartz-controlled, fluctuations not measurable
Oversampling	8-times FIR
D/A converter system	Sigma/Delta, 24-Bit-resolution
Frequency response +0 -0,2 dB	2 Hz .. 20 kHz
Total harmonic distortion / intermodulation	< 0,005 %
Effective system dynamics	94 dB
Signal noise ratio (A-weighted)	105 dB
Signal noise ratio (unweighted)	96 dB
Digital output	SP/DIF, Coax 500 mV _{eff} / 75 Ω

GENERAL

Mains power supply	See print on the back panel: 220 – 230 V~ / 50 – 60 Hz or 110 –117 V ~ / 50 – 60 Hz
Power consumption, maximum	250 VA
Power consumption, stand-by	< 2,5 VA
Case dimensions (H x W x D)	8 x 49 x 32 cm
Total system weight	9 kg
Standard finish	Black or silver eloxided
Special order finish	Chrome or painted (RAL colours)
Standard finish, side panels	Black ash, white ash, beech, alder
Special order finish, side panels	High-gloss black, high-gloss mahogany
Standard accessories	F12 remote control handset, Operation instructions Low bass module for several T+A speakers Mains cable

TROUBLE-SHOOTING

Many problems have a simple cause and a correspondingly simple solution. The following section describes a few difficulties you may encounter, and the measures you need to take to cure them.

If you find it impossible to solve a problem with the help of these notes please disconnect the unit from the mains and ask your authorised **T+A** specialist dealer for advice.

Problem:	Machine does not switch on (screen and symbol over  button not glowing).
Cause:	Mains lead not plugged in correctly.
Remedy:	Check connections, push plugs in firmly.

Problem:	Whistling or hissing sounds from the speakers.
Cause:	The aerial lead is too close to the mains lead or the Cinch cables.
Remedy:	Re-position the cables and keep them well apart. Use the household aerial or a radio cable.

Problem:	System responds correctly to manual operation of the buttons, but does not react to remote control commands.
Cause1:	Incorrectly inserted batteries or flat batteries in the remote control handset.
Remedy:	Re-fit batteries correctly or fit new ones.

Cause2:	No visual contact between system and remote control transmitter.
Remedy:	<p>Ensure direct line-of-sight contact to the remote control transmitter.</p> <p>Note that glass doors may prevent the system working properly.</p> <p>Maximum range between transmitter and receiver approx. 6 metres.</p> <p>Position the system in such a way that the RC receiver and the optional E 2000 is not subjected to direct sunlight or strong artificial lighting.</p> <p>Fluorescent and energy-saving lamps are powerful sources of interference.</p>
Cause3:	You are using an incorrect version of the optional E 2000 remote control receiver. The correct type of receiver has two exposed screw heads on the underside of the case.
Remedy:	Please refer to your T+A specialist dealer.



Problem:	Other machines (Hi-Fi units, television, video recorder or similar) respond to the RC signals from the F12 system remote control handset, or the K1 responds to the signals from other RC units.
Cause:	There is a limited number of remote control codes available, so conflicts may occasionally occur with signals from other remote control handsets.
Remedy:	The F12 remote control handset used with the K1 system can be switched to a different remote control address. As standard both the remote control transmitter and the K1 are set to RC address 1.
Note:	The F12 RC handset and the K1 must always be set to the same RC address.

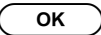
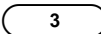
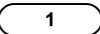
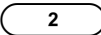

Problem:	The TUNER, CD player or recorder connected to the system do not respond to commands.
Cause:	The unit you wish to control is not selected as the source device.
Remedy:	Press the corresponding source button on the remote control unit and try again.

F12 - Changing the RC address:

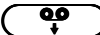
	<p>Press the buttons  and  from the numeric pad for about 10 seconds. The LED will flash. Number button  sets the remote control handset to the normal remote control level; number button  sets the alternative level. The LED will go out to confirm that the switch has taken place.</p> <p>If the batteries are removed from the F12 C transmitter for longer than 10 minutes, or if the batteries are allowed to run flat, then the F12 will always reset itself to RC address 1 when new batteries are installed.</p>
--	---

K1 - Changing the RC address:

	<p>Switch the system on, then hold the  button pressed in until a moving script appears on the screen.</p> <p>As soon as the moving message stops, immediately press the  button. This switches the system to the alternative RC address, and shows the new address on the screen as follows: 'RC-ADR 1' or 'RC-ADR 2'.</p>
--	---

Problem:	The auditioning source responds to control commands, but the system produces no output signal.
Cause:	Loudspeaker outputs switched off; 'A' or 'B' not glowing on the screen.
Remedy:	Press the appropriate button  or  on the RC handset to switch on the speakers.

Problem:	Loud hum from the speakers when playing back through TAPE or AUX/TV.
Cause:	Poor contact of a Cinch plug or a faulty Cinch lead.
Remedy:	Please check all connections and cables.

Problem:	The unit switches off repeatedly at fairly high volume levels.
Cause1:	Overheating due to heat build-up.
Remedy:	Set up the unit in a position where there is an unobstructed flow of cooling air.
Cause2:	Overheating due to insufficient loudspeaker impedance.
Remedy:	Use only loudspeakers with an impedance of at least 4 Ω (DIN normalised value); this corresponds to a minimum impedance of > 3.2 Ω .

Tuner section

Problem:	The RDS station name does not appear on the screen.
Cause1:	The station is not broadcasting RDS information, or is not correctly tuned in.
Remedy:	Tune in the station so that the tuning indicator is in the centre position.
Cause2:	The tuner is picking up interference on the same frequency, or the signal strength is too low.
Remedy:	Select only those stations which can be received with good signal strength, devoid of background hiss and interference.

Problem:	When you switch presets the RDS station name does not appear correctly, or only after a long wait.
Cause:	The name was not picked up correctly during the preset storing procedure, or the station is broadcasting the station name as a running script, contrary to the RDS norms.
Remedy:	Call up the preset and wait until the station name appears correctly on the screen, then store it manually.

Problem:	The tuner works normally, but only picks up a very small number of stations or none at all.
Cause:	The aerial system or the aerial cable itself is defective.
Remedy1:	Check the aerial lead for good contact at the aerial wall socket and at the tuner.
Remedy2:	Check the aerial cable for damage and sharp bends (kinks). If necessary, replace it with a new cable.

Problem:	After a house-move the screen continues to show a few of the old station names - but those stations cannot be picked up.
Cause:	The unit is still storing some pre-sets with station names and reception frequencies which cannot be received at the new location.
Remedy1:	Erase the non-receivable pre-sets individually - see <i>Tuner special functions: 'ERASE PRESETS'</i> .
Remedy2:	<p>Erase all stored presets.</p> <ul style="list-style-type: none"> • To do this switch on the unit and hold the  button pressed in until a moving message appears on the screen. • Wait until the moving message stops, then immediately press the TUNER button on the remote control handset and hold it in for about two seconds. The screen will now show the message: 'PRES-CLR'. <p>This erases all the stored pre-sets.</p>

CD - player

Problem:	The CD is not correctly recognised, or the screen displays the message "No Disc".
Cause1:	The CD is not correctly inserted.
Remedy:	Place the CD centrally in the drawer, printed face up.
Cause2:	The CD is dirty.
Remedy:	Clean the CD and try again.
Cause3:	The CD is damaged in the area of the Table of Contents (TOC).
Remedy:	No remedy; the CD is unusable.
Cause4:	The machine has been allowed to get very cool (e.g. in transit) and condensation has formed on the optics of the laser sensor.
Remedy:	Leave the machine in a warm, well-ventilated place for about an hour to warm up thoroughly.

Problem:	The CD "jumps" or stops during playback.
Cause:	The CD is dirty or damaged.
Remedy:	Clean the CD and try again.

Disposing of exhausted batteries

Exhausted batteries must never be thrown into the household waste! They should be returned to the battery vendor (specialist dealer) or your local toxic waste collection point, so that they can be recycled or disposed in a proper way. Most local authorities provide collection centres for such waste, and some provide pick-up vehicles for old batteries

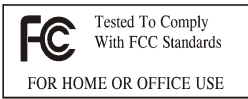

FCC Information to the user **(for use in the United States of America only)**

Class B digital device – instructions:

Note: This equipment has been tested and found to comply with the limits for a Class B digital device, pursuant to Part 15 of the FCC Rules. These limits are designed to provide reasonable protection against harmful interference in a residential installation. This equipment generates, uses and can radiate radio frequency energy and, if not installed and used in accordance with the instructions, may cause harmful interference to radio communications. However, there is no guarantee that interference will not occur in a particular installation. If this equipment does cause harmful interference to radio or television reception, which can be determined by turning the equipment off and on, the user is encouraged to try to correct the interference by one or more of the following measures:

- Reorient or relocate the receiving antenna.
- Increase the separation between the equipment and receiver.
- Connect the equipment into an outlet on a circuit different from that to which the receiver is connected.
- Consult the dealer or an experienced radio/TV technician for help.

T+A elektroakustik GmbH & Co KG
Herford * Germany

Free Manuals Download Website

<http://myh66.com>

<http://usermanuals.us>

<http://www.somanuals.com>

<http://www.4manuals.cc>

<http://www.manual-lib.com>

<http://www.404manual.com>

<http://www.luxmanual.com>

<http://aubethermostatmanual.com>

Golf course search by state

<http://golfingnear.com>

Email search by domain

<http://emailbydomain.com>

Auto manuals search

<http://auto.somanuals.com>

TV manuals search

<http://tv.somanuals.com>