

Software version TC2.1
DECEMBER 2009



Profile 42"



Profile 52"



Profile 52" Dual



Profile 65"

TANDBERG Profile

- with Codec C60

Administrator Guide

What's in this guide?

The top menu bar and the entries in the Table of Contents are all hyperlinks, just click on them to go to the topic.

We recommend you visit the TANDBERG web site regularly for updated versions of this guide. Go to: <http://www.tandberg.com/docs>

Table of Contents

Introduction

- What's new 5
 - What's new this guide 5
 - What's new in this software version 5
- Intellectual Property Rights 6
- Trademark 6
- Disclaimer 6
- Patent Information 6
- Copyright and License Notice 6
- Safety Instructions 7
 - Safety Instructions 7
 - FCC rules 15B, acc. to Class A limits 8
 - EMC A-Class declaration 8
 - FCC rules 15B, acc. to Class A limits 8
 - EMC A-Class declaration 8
- Environmental Issues 9

Getting started

- System overview 11
 - TANDBERG Profile 42" 11
 - TANDBERG Profile 52" 12
 - TANDBERG Profile 52" Dual 13
 - TANDBERG Profile 65" 14
- Codec cable configuration 15
- Using the Remote Control 16
- Initial configurations 18
 - Waking up the system 18
 - Verify IP address settings 18
 - If you need to set a static IP address 18
 - Adding the system to the network 19
 - Verify your settings 19
 - Adjusting the date and time settings 19
 - Setting a menu password 20

About the menus

- The Home menu 22
- The Settings menu 22
- The Advanced menu 22

The system settings menus

- The Advanced menus 24
 - How to change a value 24
 - Description of each setting 24
 - The search functionality 25
 - How to change the menu password 26

The system settings library

- Description of the System settings 28
 - The Audio settings 28
 - The Camera settings 30
 - The Conference settings 31
 - The H323 Profile settings 32
 - The Network settings 33
 - The Network Services settings 35
 - The Phonebook settings 37
 - The Provisioning settings 37
 - The Serial Port settings 37
 - The SIP Profile settings 38
 - The Standby settings 39
 - The System Unit settings 39
 - The Time settings 40
 - The Video settings 41

Cameras

- The PrecisionHD 1080p camera 48
 - Connecting the camera 49
 - Best view—Face recognition 50
 - Using Best view 50
 - Video output formats 51
 - DIP switch settings for video output formats 51
 - Line voltage frequency 51

Appendices

General room guidelines	53	Profile 42" with wall mount foot	76
The physical conditions	53	Profile 42" with wheelbase foot	77
The room equipment.....	53	Profile 52" with standalone foot.....	78
Environmental considerations	53	Profile 52" with wall mount foot.....	79
The audio quality.....	54	Profile 52" with wheelbase foot	80
Natural communication.....	54	Profile 52" Dual with standalone foot	81
Guidelines for meeting room setup	55	Profile wall mount setup	82
Sharing a PC presentation	56	Profile 65" with standalone foot.....	83
Other presentation sources	56	Profile 65" with wall mounting foot	84
TANDBERG Remote Control TRC5.....	57	PrecisionHD 1080p camera.....	85
Password protection	58	Technical specifications for Profile 42"/52".....	86
Setting the codec administrator password	58	Technical specifications for Profile 65"	88
Password protection of the web interface.....	58		
Setting the menu password	58		
Startup script	59		
Adding a startup script	59		
The web interface	60		
Password protection of the web interface.....	60		
The system info page.....	60		
The Upgrade software page	61		
The Advanced configuration page	62		
The Advanced configuration, search functionality	63		
The Wallpaper page.....	64		
The Call page.....	65		
The SSL Certificates page	66		
The XML files page.....	67		
The Logs page.....	68		
The Add release key page.....	69		
TANDBERG DNAM for Profile 42"/52"	70		
The DNAM Loudspeaker Cabinet	70		
The DNAM Amplifier.....	70		
TANDBERG DNAM for Profile 65"	71		
The DNAM Loudspeaker Cabinet	71		
The DNAM Amplifier.....	71		
Supported RFCs in SIP	72		
Current RFCs and drafts supported in SIP	72		
Media capabilities supported in SIP	72		
China RoHS table	73		
CE Declaration for TANDBERG Profile	74		
Dimensions	75		
Profile 42" with standalone foot.....	75		

Chapter 1

Introduction

Thank you for choosing TANDBERG!
TANDBERG Profile has been designed to give you many years of safe, reliable operation.

How to read this document

You will find that some places information has been copied from other chapters (but adapted, when needed) to let you have all the relevant information there and then. This helps eliminating the need to read through long sections before you can even think of getting started.

Our main objective with this user guide is to address your goals and needs. Please let us know how well we succeeded!

We recommend you visit the TANDBERG web site regularly for updated versions of the manual.

Go to: ► <http://www.tandberg.com/docs>



In this chapter...

- TANDBERG Profile At a glance
- Intellectual property rights
- Trademark
- Copyright
- Disclaimer
- Patent information
- Safety instructions
- Environmental issues

What's new

What's new this guide

The TANDBERG Profile 65" with Codec C60 has been added to the Profile series and is described in this guide.



What's new in this software version

The latest software versions for the Codec C60 is TC2.1. The Advanced configurations menu changes are described on this page.

For a complete overview of the news and changes from TC2.0 to TC2.1 we recommend reading the software release notes

[TANDBERG TC Software Release Notes \(TC2\)](#).

Go to: <http://www.tandberg.com/docs>

Advanced configuration—Settings added

Standby StandbyAction

Value space: <None/PrivacyPosition>

- None: No action.
- PrivacyPosition: Turns the camera to a sideways position for privacy.

NOTE! The settings within the Experimental menu can be used 'as is'. The content of the Experimental menu will change in future software releases.

Experimental Audio Input Microphone [1..4] EchoControl HighPassFilter

Value space: <On/Off>

Experimental Video OptimalDefinition Profile

Value space: <Normal/Medium/High>

See the table below to find when to choose Normal, Medium Or High for the optimal definition profile.

Advanced configuration—Value space changed

SerialPort BaudRate

Previous version: <9600/19200/38400/115200>

New value space: <9600/19200/38400/57600/115200>

SystemUnit MenuLanguage

Previous version: <English/Norwegian/Swedish/German/French/Italian/Japanese/Chinese/Russian/Spanish/Korean/Turkish>

New value space: <English/Norwegian/Swedish/German/French/Italian/Japanese/Russian/Spanish/Korean/Finnish/ChineseSimplified/ChineseTraditional/PortugueseBrazilian/Turkish/Polish>

Advanced configuration—Removed settings

The Experimental settings are subject to change without notice. They can be used "as is". In version TC2.1 the following settings are removed:

- Experimental Audio Input Line [3..4] Equalizer Mode
- Experimental Audio Input Line [3..4] Equalizer Number
- Experimental Audio Output Line [3..6] Equalizer Mode
- Experimental Audio Output Line [3..6] Equalizer Number
- Experimental SoftwareUpgrade Mode
- Experimental SoftwareUpgrade ServerAddress

Experimental > Video > Optimal definition, for systems supporting 1080p					
	w288p30	w448p30	w576p30	720p30	1080p30
Normal	256kbit/s	512 kbit/s	768 kbit/s	1152 kbit/s	2560 kbit/s
Medium	128kbit/s	384 kbit/s	512 kbit/s	768 kbit/s	1920 kbit/s
High	128kbit/s	256 kbit/s	512 kbit/s	768 kbit/s	1472 kbit/s

Experimental > Video > Optimal definition, for systems supporting 720p60					
	w144p60	w288p60	w448p60	w576p60	720p60
Normal	128kbit/s	512 kbit/s	1152 kbit/s	1472 kbit/s	2240 kbit/s
Medium	128kbit/s	384 kbit/s	768 kbit/s	1152 kbit/s	1472 kbit/s
High	128kbit/s	256 kbit/s	512 kbit/s	768 kbit/s	1152 kbit/s

Intellectual Property Rights

This Administrator Guide and the Products to which it relates contain information that is proprietary to TANDBERG and its licensors. Information regarding the Products is found on the page entitled License Agreements and Patent Information.

This Administrator Guide may be reproduced in its entirety, including all copyright and intellectual property notices, in limited quantities in connection with the use of the Products. Except for the limited exception set forth in the previous sentence, no part of this Administrator Guide may be reproduced, stored in a retrieval system, or transmitted, in any form, or by any means, electronically, mechanically, by photocopying, or otherwise, without the prior written permission of TANDBERG. Requests for such permission should be addressed to tandberg@tandberg.com.

Trademark

TANDBERG® is a registered trademark belonging to Tandberg ASA. Other trademarks used in this document are the property of their respective holders.

COPYRIGHT © 2008–2009, TANDBERG

All rights reserved.

Philip Pedersens vei 20

1366 Lysaker, Norway

Tel: +47 67 125 125 Fax: +47 67 125 234

E-mail: tandberg@tandberg.com

Disclaimer

The specifications for the Products and the information in this document are subject to change at any time, without notice, by TANDBERG.

Every effort has been made to supply complete and accurate information in this Administrator Guide, however, TANDBERG assumes no responsibility or liability for any errors or inaccuracies that may appear in this document.

INTELLECTUAL PROPERTY RIGHTS

The Products that are covered by this Administrator Guide are protected under copyright, patent, and other intellectual property rights of various jurisdictions. Any applicable software licenses and any limited warranty are located in the Copyright and License Notice section in this guide.

This Product is

COPYRIGHT © 2008–2009, TANDBERG

All rights reserved.

Patent Information

The products described in this manual are covered by one or more of the following patents:

US6,584,077	US5,838,664	US5,600,646
US5,003,532	US5,768,263	US5,991,277
US7,034,860	US7,010,119	EP01953201
US6.731.334	GB1338127	

Other patents pending.

Please view ► www.tandberg.com/tandberg_pm.jsp for an updated list

Copyright and License Notice

The product that is covered by this Administrator Guide is protected under copyright, patent, and other intellectual property rights of various jurisdictions. This product is Copyright © 2009, Tandberg Telecom AS. All rights reserved. This product includes copyrighted software licensed from others.

A document describing the copyright notices and the terms and conditions of use can be found at: ► <http://www.tandberg.com/docs>

See the document: [TANDBERG Codecs C90C60C20 Copyright and License Information \(TC20\).pdf](#).

IMPORTANT: USE OF THIS PRODUCT IS SUBJECT IN ALL CASES TO THE COPYRIGHT RIGHTS AND THE TERMS AND CONDITIONS OF USE REFERRED TO ABOVE. USE OF THIS PRODUCT CONSTITUTES AGREEMENT TO SUCH TERMS AND CONDITIONS.

Safety Instructions

For your protection please read these safety instructions completely before you connect the equipment to the power source. Carefully observe all warnings, precautions and instructions both on the apparatus and in these operating instructions.

Retain this manual for future reference.

Safety Instructions

Water and Moisture

Do not operate the apparatus under or near water – for example near a bathtub, kitchen sink, or laundry tub, in a wet basement, near a swimming pool or in other areas with high humidity.

- Never install jacks for communication cables in wet locations unless the jack is specifically designed for wet locations.
- Do not touch the product with wet hands.

Cleaning

Unplug the apparatus from communication lines, mains power-outlet or any power source before cleaning or polishing. Do not use liquid cleaners or aerosol cleaners. Use a lint-free cloth lightly moistened with water for cleaning the exterior of the apparatus.

Ventilation

Do not block any of the ventilation openings of the apparatus. Never cover the slots and openings with a cloth or other material. Never install the apparatus near heat sources such as radiators, heat registers, stoves, or other apparatus (including amplifiers) that produce heat.

Do not place the product in direct sunlight or close to a surface directly heated by the sun.

Lightning

Never use this apparatus, or connect/disconnect communication cables or power cables during lightning storms.

Dust

Do not operate the apparatus in areas with high concentration of dust.

Vibration

Do not operate the apparatus in areas with vibration or place it on an unstable surface.

Power Connection and Hazardous Voltage

The product may have hazardous voltage inside.

- Never attempt to open this product, or any peripherals connected to the product, where this action requires a tool.
- This product should always be powered from an earthed power outlet.
- Never connect attached power supply cord to other products.
- In case any parts of the product has visual damage never attempt to connect main power, or any other power source, before consulting service personnel
- The plug connecting the power cord to the product/power supply serves as the main disconnect device for this equipment. The power cord must always be easily accessible.

- Route the power cord so as to avoid it being walked on or pinched by items placed upon or against it. Pay particular attention to the plugs, receptacles and the point where the cord exits from the apparatus.
- Do not tug the power cord.
- If the provided plug does not fit into your outlet, consult an electrician.
- Never install cables, or any peripherals, without first unplugging the device from its power source.

NOTE: The TANDBERG Profile 42"/52"/52"Dual/65" must be installed near a socket-outlet. The socket-outlet shall be easily accessible after installation.

Servicing

- Do not attempt to service the apparatus yourself as opening or removing covers may expose you to dangerous voltages or other hazards, and will void the warranty. Refer all servicing to qualified service personnel.
- Unplug the apparatus from its power source and refer servicing to qualified personnel under the following conditions:
 - If the power cord or plug is damaged or frayed.
 - If liquid has been spilled into the apparatus.
 - If objects have fallen into the apparatus.
 - If the apparatus has been exposed to rain or moisture
 - If the apparatus has been subjected to excessive shock by being dropped.
 - If the cabinet has been damaged.
 - If the apparatus seems to be overheated.
 - If the apparatus emits smoke or abnormal odor.
 - If the apparatus fails to operate in accordance with the operating instructions.

Accessories

Use only accessories specified by the manufacturer, or sold with the apparatus.

Communication Lines

Do not use communication equipment to report a gas leak in the vicinity of the leak.

FCC rules 15B, acc. to Class A limits

Applies to: TANDBERG Profile 42"/52"/52"Dual

Class A digital device, pursuant to part 15 of the FCC Rules (For the US only).

Note : This equipment has been tested and found to comply with the limits for a Class A digital device, pursuant to part 15 of the FCC Rules. These limits are designed to provide reasonable protection against harmful interference when the equipment is operated in a commercial environment. This equipment generates, uses and can radiate radio frequency energy and, if not installed and used in accordance with the instruction manual, may cause harmful interference to radio communications. Operation of this equipment in a residential area is likely to cause harmful interference in which case the user will be required to correct the interference at his own expense.

EMC A-Class declaration

Applies to: TANDBERG Profile 42"/52"/52"Dual

声 明

此为 A 级产品，在生活环境中，该产品可能会造成无线电干扰。在这种情况下，可能需要用户对其干扰采取切实可行的措施。

WARNING:

This is a class A product. In a domestic environment this product may cause radio interference in which case the user may be required to take adequate measures.

Environmental Issues

Thank you for buying a product which contributes to a reduction in pollution, and thereby helps save the environment. Our products reduce the need for travel and transport and thereby reduce pollution. Our products have either none or few consumable parts (chemicals, toner, gas, paper).

TANDBERG's Environmental Policy

Environmental stewardship is important to TANDBERG's culture. As a global company with strong corporate values, TANDBERG is committed to following international environmental legislation and designing technologies that help companies, individuals and communities creatively address environmental challenges.

TANDBERG's environmental objectives are to:

- Develop products that reduce energy consumption, CO2 emissions, and traffic congestion
- Provide products and services that improve quality of life for our customers
- Produce products that can be recycled or disposed of safely at the end of product life
- Comply with all relevant environmental legislation.

Digital User Guides

TANDBERG is pleased to announce that we have replaced the printed versions of our user guides with digital versions available on the TANDBERG web site: ► <http://www.tandberg.com/docs>. The environmental benefits of this are significant. The user guides can still be printed locally, whenever needed.

European Environmental Directives

As a manufacturer of electrical and electronic equipment TANDBERG is responsible for compliance with the requirements in the European Directives 2002/96/EC (WEEE - Waste Electrical and Electronic Equipment) and 2002/95/EC (RoHS).

The primary aim of the WEEE Directive and RoHS Directive is to reduce the impact of disposal of electrical and electronic equipment at end-of-life. The WEEE Directive aims to reduce the amount of waste electrical and electronic equipment sent for disposal to landfill or incineration by requiring producers to arrange for collection and recycling. The RoHS Directive bans the use of certain heavy metals and brominated flame retardants to reduce the environmental impact of WEEE which is in landfill or incinerated.

TANDBERG has implemented necessary process changes to comply with the European WEEE Directive (2002/96/EC) and the European RoHS Directive (2002/95/EC).

Waste Handling

In order to avoid the dissemination of hazardous substances in our environment and to diminish the pressure on natural resources, we encourage you to use the appropriate recycling systems in your area. Those systems will reuse or recycle most of the materials of your end of life equipment in a sound way.

 TANDBERG products put on the market after August 2005 are marked with a crossed-out wheeled bin symbol that invites you to use those take-back systems.

Please contact your local supplier, the regional waste administration or visit our web page ► <http://www.tandberg.com/recycling> if you need more information on the collection and recycling system in your area.

Information for Recyclers

As part of compliance with the European WEEE Directive, TANDBERG provides recycling information on request for all types of new equipment put on the market in Europe after August 13th 2005.

Please contact TANDBERG and provide the following details for the product for which you would like to receive recycling information:

- Model number of TANDBERG product
- Your company's name
- Contact name
- Address
- Telephone number
- E-mail.

Chapter 2

Getting started

This chapter introduces you to the video system and gets you up and going.

The guide has been divided into several chapters, all of which provide different information. You can access the chapters directly by clicking on the menu bar at the top of this page.



In this chapter...

- ▶ System overview
- ▶ Cable configurations
- ▶ Using the remote control
- ▶ Initial configurations
 - ▶ Waking up the system
 - ▶ Verify IP address settings
 - ▶ Setting a static IP address
 - ▶ Add the system to the network
 - ▶ Verify your settings
 - ▶ Date and time settings
 - ▶ Menu password

System overview

See the installation sheet for the TANDBERG Profile 42" for instructions on how to install the system.

Codec C60

- Full HD video
- High resolution data sharing
- Full HD Multisite
- Rich I/O capabilities

PrecisionHD 1080p camera

Full HD Camera designed for visual communication with:

- 12 x optical zoom
- Fast and precise pan, tilt and zoom

Monitor

42" Full HD LCD, 16:9, 1080 x 1920 resolution

Audio module

Wide band audio module supporting:

- 20 kHz AAC-LD
- Full echo canceling
- Stereo

Audio amplifier

Optimized DNAM for TANDBERG Profile providing crystal clear and natural audio.

Microphones

3 x Microphones

Remote control

- 1 x TANDBERG Remote Control TRC5
- 4 x AAA batteries

Foot stand

- 1 x Foot stand
- Standalone, wheelbase or wall mounting

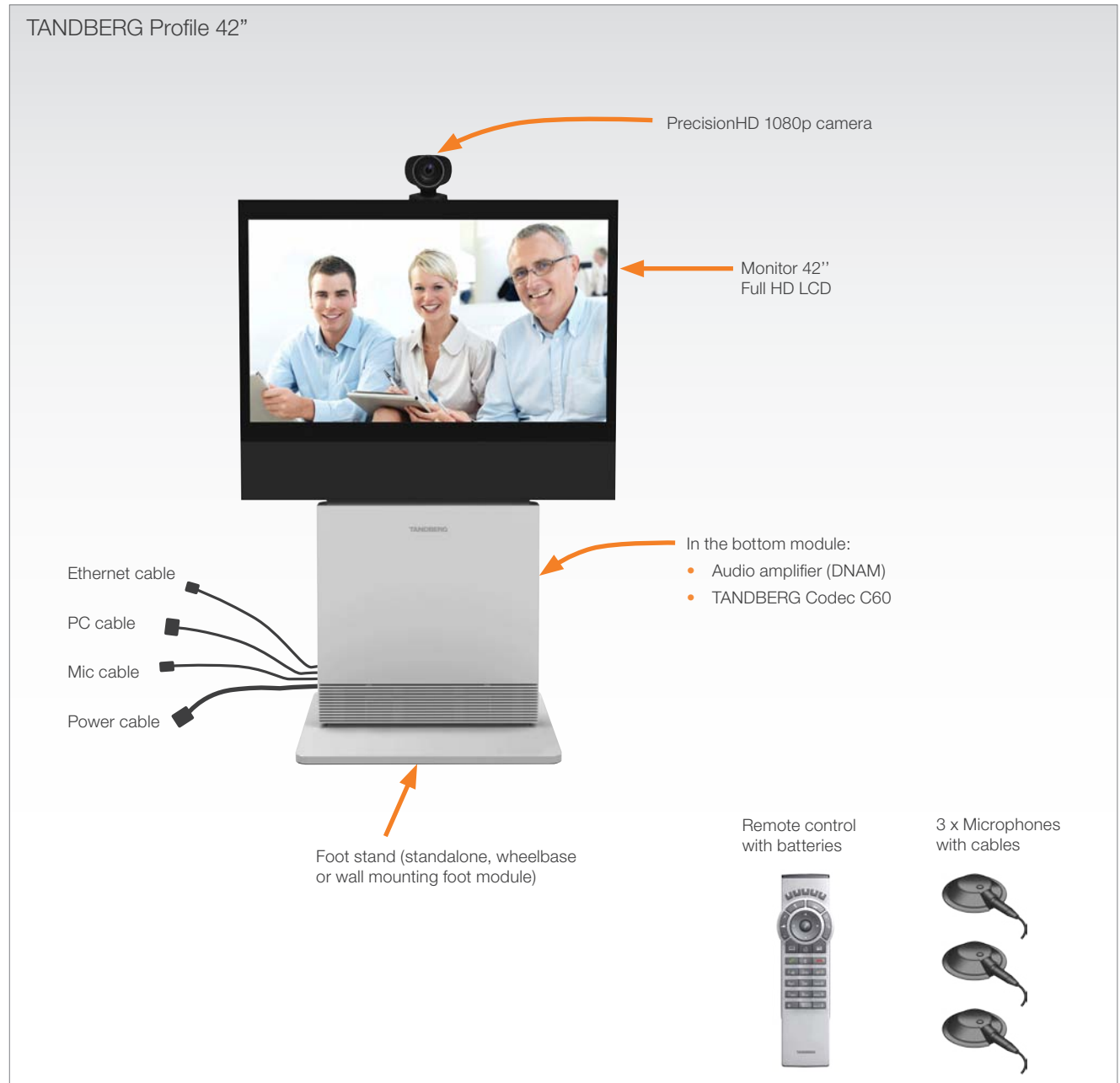

System overview

See the installation sheet for the TANDBERG Profile 52" for instructions on how to install the system.

Codec C60

- Full HD video
- High resolution data sharing
- Full HD Multisite
- Rich I/O capabilities

PrecisionHD 1080p camera

Full HD Camera designed for visual communication with:

- 12 x optical zoom
- Fast and precise pan, tilt and zoom

Monitor

52" Full HD LCD, 16:9, 1080 x 1920 resolution

Audio module

Wide band audio module supporting:

- 20 kHz AAC-LD
- Full echo canceling
- Stereo

Audio amplifier

Optimized DNAM for TANDBERG Profile providing crystal clear and natural audio.

Microphones

3 x Microphones

Remote control

- 1 x TANDBERG Remote Control TRC5
- 4 x AAA batteries

Foot stand

- 1 x Foot stand
- Standalone, wheelbase or wall mounting



System overview

See the installation sheet for the TANDBERG Profile 52" for instructions on how to install the system.

Codec C60

- Full HD video
- High resolution data sharing
- Full HD Multisite
- Rich I/O capabilities

PrecisionHD 1080p camera

Full HD Camera designed for visual communication with:

- 12 x optical zoom
- Fast and precise pan, tilt and zoom

Dual monitor

Dual 52" Full HD LCD, 16:9, 1080 x 1920 resolution

Audio module

Wide band audio module supporting:

- 20 kHz AAC-LD
- Full echo canceling
- Stereo

Audio amplifier

Optimized DNAM for TANDBERG Profile providing crystal clear and natural audio.

Microphones

4 x Microphones

Remote control

- 1 x TANDBERG Remote Control TRC5
- 4 x AAA batteries

Foot stand

- 1 x Foot stand
- Standalone or wall mounting

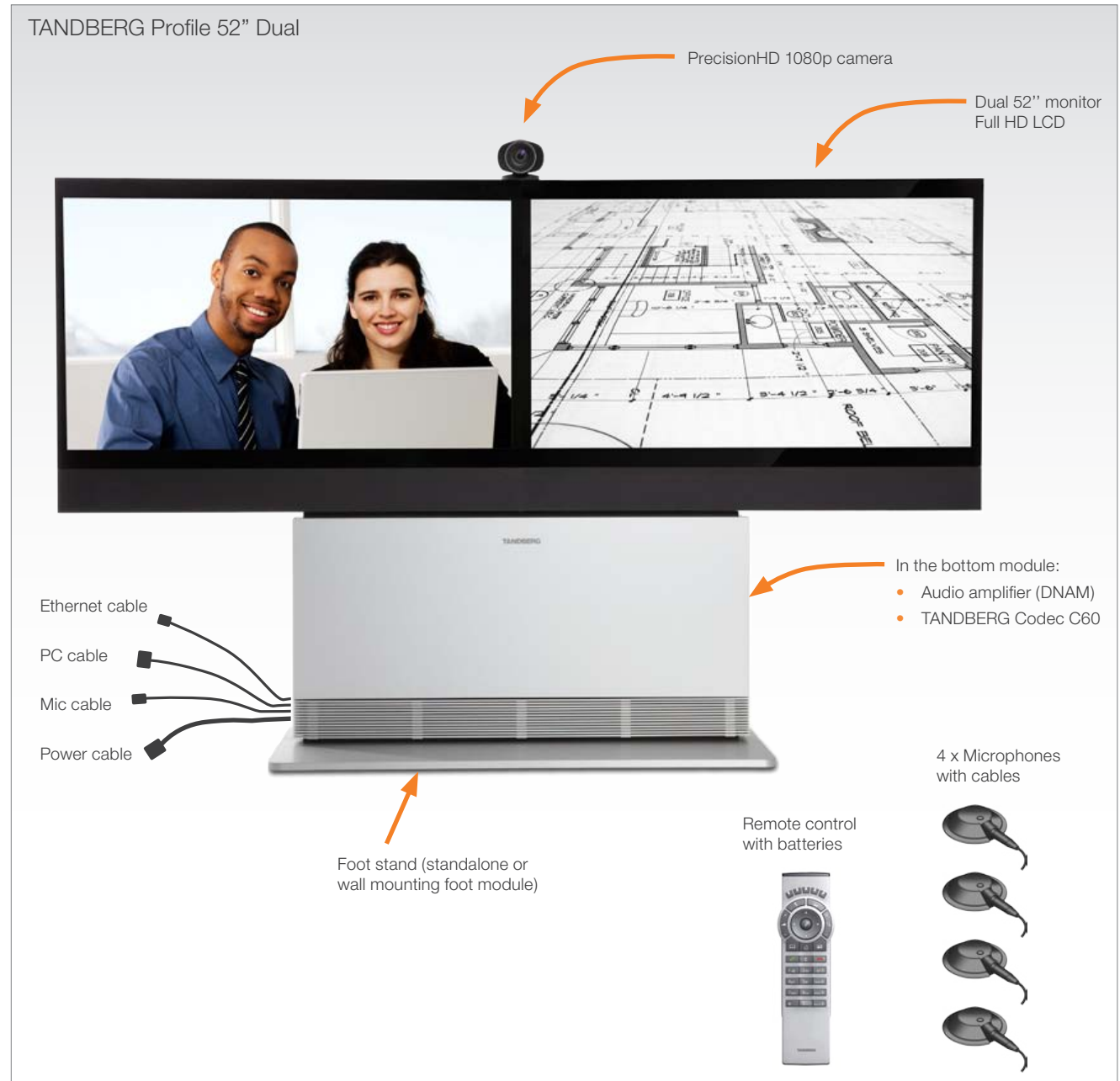

System overview

See the TANDBERG Profile 65" Installation Sheet for instructions of how to assemble the system.

Codec C60

- Full HD video
- High resolution data sharing
- Full HD Multisite
- Rich I/O capabilities

PrecisionHD 1080p camera

Full HD Camera designed for Visual communication with:

- 12 x optical zoom
- Fast and precise pan, tilt and zoom

Monitor 65"

65" Full HD LCD, 16:9, 1080 x 1920 resolution

Audio module

Wide band audio module supporting:

- 20 kHz AAC-LD
- Full echo canceling
- Stereo

Audio amplifier

Optimized DNAM for TANDBERG Profile 65" providing crystal clear and natural audio.

Microphones

3 x Microphones

Remote control

- TANDBERG Remote Control TRC5
- 4 x AAA batteries

Foot stand

Foot stand (standalone or wall mounting)



Codec cable configuration

The illustration shows you the basic setup when connecting the monitor, PC, camera, microphone, LAN and line voltage to the TANDBERG Codec C60.

INPUTS	OUTPUTS	TANDBERG Basic Setup
1 ←	1 →	The main connectors for TANDBERG basic setup are highlighted in orange.



Make sure the codec has been switched off and disconnected from the line voltage whenever connecting or disconnecting other equipment.

Using the Remote Control

The functions keys in the upper part of the remote control reflects the soft keys on screen.

... and the middle part of the remote control is used to handle the video part of the call.

... while the lower part of the remote control resembles very much the keypad of a mobile phone

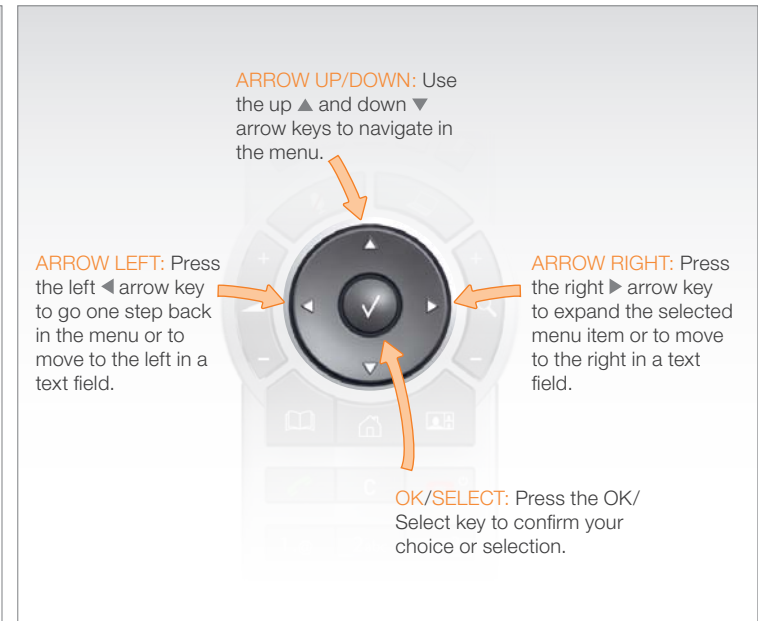
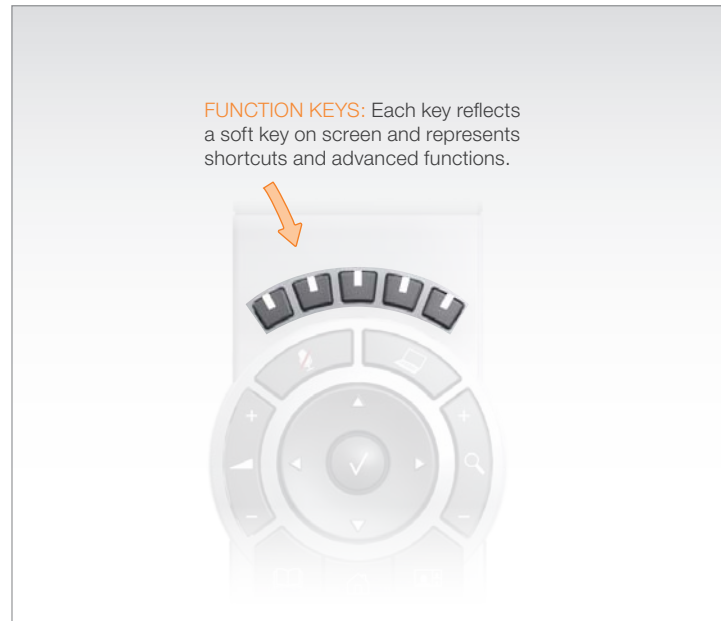

Batteries

Make sure the remote control has working batteries (4 x AAA batteries).

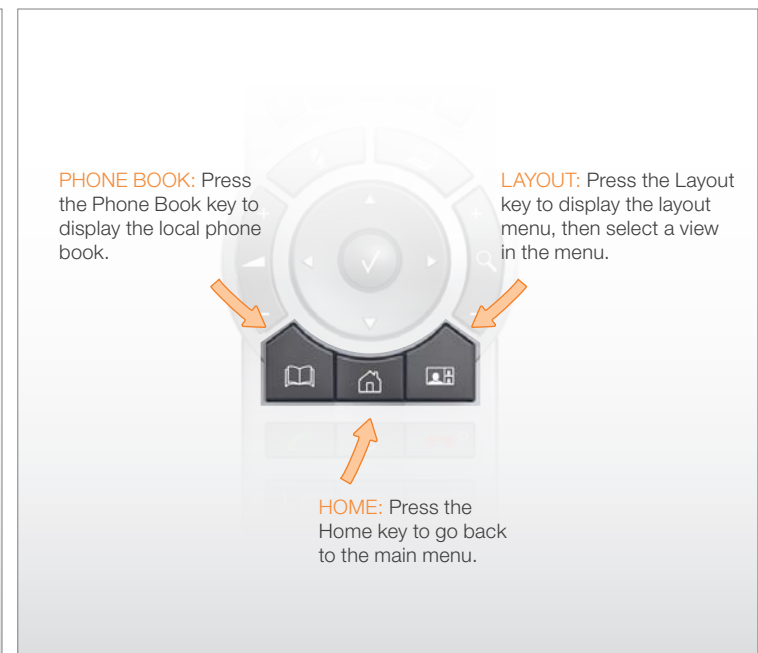
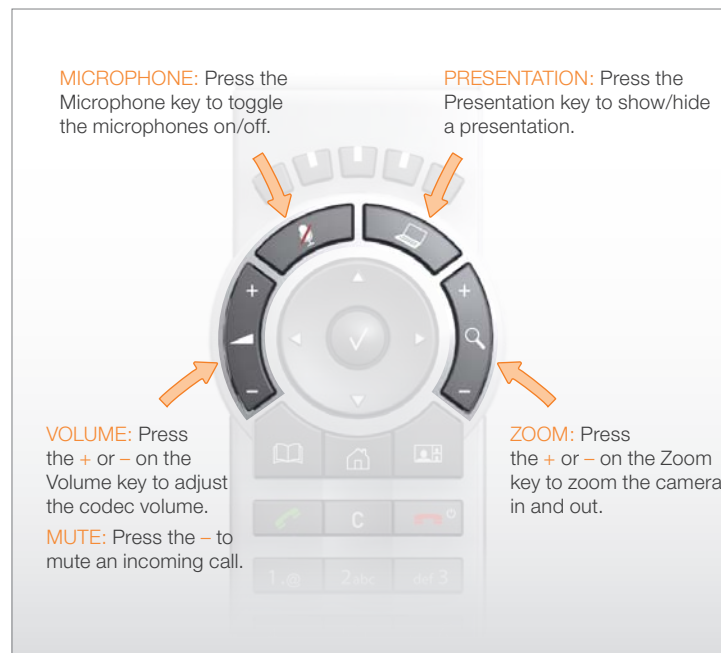

Using the Remote Control, cont...



The functions keys in the upper part of the remote control reflects the soft keys on screen.

... and the middle part of the remote control is used to handle the video part of the call.

... while the lower part of the remote control resembles very much the keypad of a mobile phone

CALL KEY

INITIATE CALL: Select a name from the Phone book or enter the name, number or URI and press the Call key to initiate the call.

SHORTCUT TO RECENT CALLS: Use the Call button as a shortcut to Recent Calls when the Call menu is not visible.

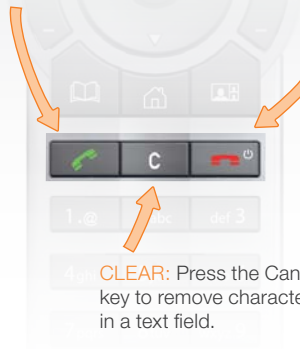

END CALL, STANDBY: Press the End Call key to end a call, or when idle, press and hold the key to go into standby mode.

CLEAR: Press the Cancel key to remove characters in a text field.

ALPHANUMERIC KEYPAD

Use the keypad in the same way as you would use a cellular phone.



0-9, a-z, period (.), @, space, *: Press a key repeatedly to toggle between the options displayed on each key.

abc/123 #: Press the # key to toggle between lower case characters and numbers.

Waking up the system

Press any key on the remote control to wake up the system.

Press the **HOME** key to show the menu on screen

Touch the rubber line sensors along the sides to wake up the system



IR sensor range (DIP switch setting)

The IR sensor has a short and long range. Open the battery cover and remove the batteries to set the DIP switch.

- Short range (1 m): Move the DIP switch down
- Long range: Move the DIP switch up.

The DIP switch



Initial configurations

Before you can start making calls with the system you will need to set the IP address, add the system to the network and check if the date and time settings needs to be adjusted. When starting up the system the first time the menu password is not set. But, when done it is recommended to set a menu password to get access to the Advanced configuration menu.

1 Waking up the system

If no menu on screen, press **Home** (🏠) on the remote control to show the menu on screen.

If the system does not show any menu on screen:

1. Make sure the monitor has been turned on
2. Make sure the remote control has the batteries installed
3. Make sure the codec has been turned on
4. If the system has just been turned on, wait a few minutes to allow the system to startup

2 Verify IP address settings

How to go to the System Information page to verify the IP address:

1. Navigate to **Settings > System Information** to open the System information page.
2. When the IP address is automatically assigned from a DHCP server, the network IP address of the codec is shown on the System Information page.
3. Press **Home** (🏠) to exit.

Password protection of the Advanced menu

If a menu password has been set you will be asked to enter a password to get access to the Advanced menu. By default, the menu password is not set when starting up the system for the first time.

After having finished the initial configurations it is recommended to define an menu password.

3 If you need to set a static IP address

How to set the static IP address:

1. Navigate to **Settings > Advanced > IP settings**.
2. Set **IP Assignment** to **Static**. Press **OK** (✓) to save the change.
3. Enter the **IP Address**, **Subnet Mask** and **Gateway address** in the address fields. The sequence is shown below.
4. Navigate to **OK** to save the changes, or **Cancel** to leave without saving.
5. Press **Home** (🏠) to exit.

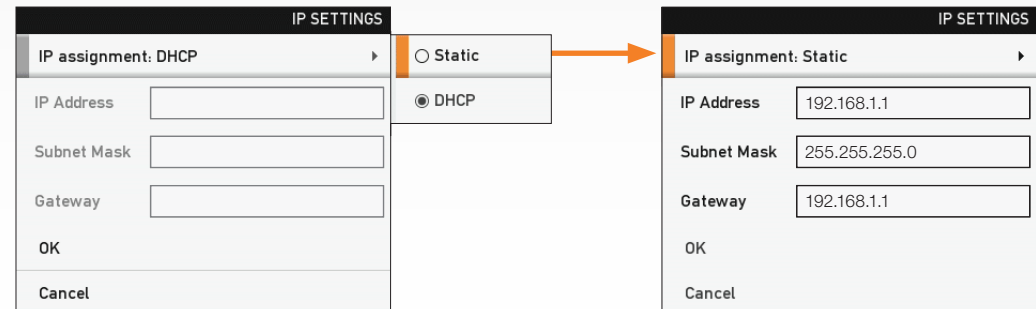

4 Adding the system to the network

Your service provider should have provided you with the information you need to get online.

- For H.323 type of communication, this will include such things as system name, H.323 alias, gatekeeper address, etc.
- For SIP type of communication, similar type of information will be supplied.
- For networks administrated through TMS (TANDBERG Management Suite), your TMS administrator will be able to assist you when configuring.

The H.323 and SIP profiles are configured from the Advanced configurations menu:

Navigate to **Settings > Advanced > Advanced configuration** and make a search for H323 or SIP, or select **H323 > Profile 1** or **SIP > Profile 1** from the menu

- Expand the items in need of modification and enter the information supplied by your service provider.

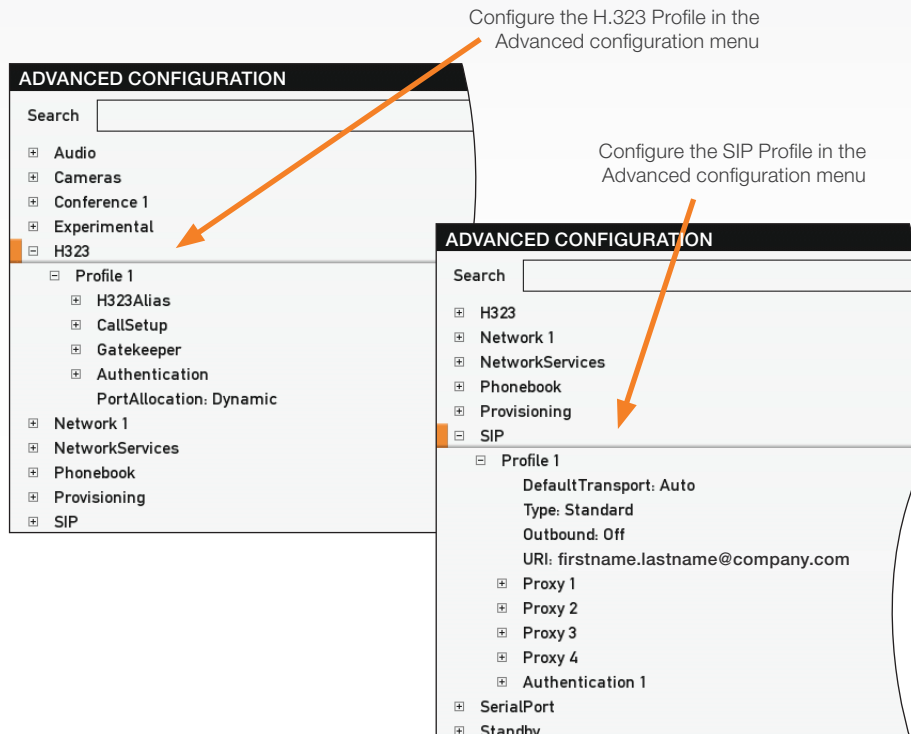

5 Verify your settings

We strongly recommend that you verify the settings by inspecting the System Information list.

You do this by accessing the System Information in the same way as you did when you verified you IP address setting.

1. Navigate to **Settings > System Information**
2. Verify the previous configurations.
 - If you successfully registered to a Gatekeeper the **Status** will show **Registered**. If the registration failed the **Status** will show **Not registered**.
 - If you successfully registered to a SIP server the **Status** will show **Registered**. If the registration failed the **Status** will show **Not registered**.
3. Press **Home** (🏠) to exit.

6 Adjusting the date and time settings

Verify the date and time to see if the date and time settings need to be adjusted. The date and time is located in the upper right corner on screen.

How to adjust the date and time settings:

1. Navigate to **Settings > Date and time**
2. When **Set date and time** is set to **Auto** there will be an automatic update of the date and time settings. If you want to manually adjust the date and time settings, select **Manual** and enter the **Day, Month, Year** and **Time**. After having adjusted the settings manually you can set the **Set date and time** back to **Auto** for automatic update.
3. Select the appropriate **Time zone** from the list of GMT time zones.
4. Select the appropriate **Date format** from the list.
5. Select the appropriate **Time format** from the list.
6. Press **Home** (🏠) to exit.

7

Setting a menu password

It is highly recommended to define a password to access the Advanced menus. Changing these settings may affect the behavior of the system and should be done by the system administrator.

NOTE! The menu password will only apply to the Advanced menu. The codec and the web interface can be password protected with an administrator password. See the [Password protection](#) section in the Appendices for a detailed description.

NOTE! When you define or change a password make sure you save a copy of the password in a safe place.

How to set the menu password

Navigate to **Settings > Advanced > Change password**

1. On the remote control, press the # key to toggle between lower or upper case characters and numbers: abc/ABC/123
2. Enter the menu password. The password you enter is hidden, as each character is replaced with a star (*).
3. Navigate to **Save** to save the changes, or **Cancel** to leave without saving.
4. Press **Home** () to exit.

Chapter 3

About the menus



In this chapter...
▶ Explains the menu system

About the menus

The menu path to the Advanced configuration menu:

1. The **Home** menu
2. The **Settings** menu
3. The **Advanced** menu
4. The **Advanced configuration** menu

The user documentation structure

- The **Administrator Guide** explains all settings found in the **Advanced** and **Advanced configuration** menus.
- The **User Guide** explains how to make use of the video system, which includes making calls and explaining about the settings found in the **Home** menu, **Settings** menu and the **Programmable softbuttons** from the **Advanced** menu.

Navigating in the menus

Use the remote control to navigate in the menus:

- Use the arrows down/up to select a menu item
- Use the arrow right to expand the selection
- Use the arrow left to go one step back

Changing a value

- Select a value from a drop down list and press the OK button to save, or press the left arrow to leave without saving.
- Enter a value/text in a value/text field. Press Save to save the change or Cancel to leave without saving.



Download the TANDBERG user guides from the web site.
Go to: <http://www.tandberg.com/docs>

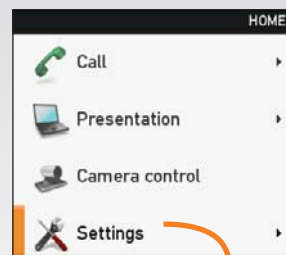

The Home menu

The **Home** menu is explained in the **TANDBERG Profile User Guide**.

- **Call**: Menu for making calls.
- **Presentation**: Select a presentation source.
- **Camera control**: Control the camera settings.
- **Settings**: Configure the system.

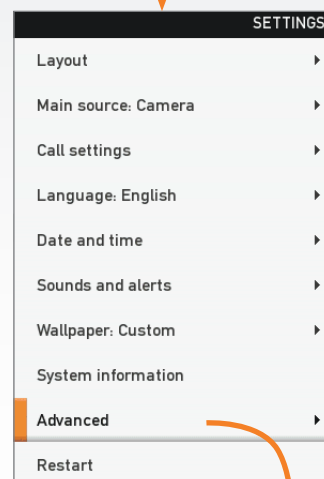

The Settings menu

The **Settings** menu is explained in the **TANDBERG Profile User Guide**.

- **Layout**: Select screen layout, including selfview.
- **Main source**: Select the main video source.
- **Call settings**: Configure the default bit rate and auto answer settings.
- **Language**: Select the preferred menu language.
- **Date and time**: Configure date and time settings.
- **Sounds and alerts**: Select a ring tone, the ring tone volume and key tone.
- **Wallpaper**: Select the background picture on screen
- **System Information**: See an overview of the system configurations
- **Advanced**: Configure the advanced settings.
- **Restart**: Select this option to restart the system.

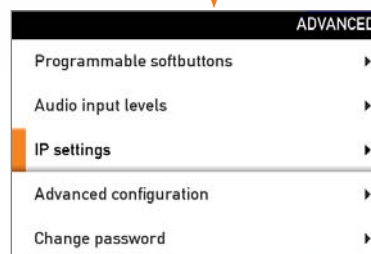

The Advanced menu

NOTE! The Advanced menu can be password protected with a menu password.

- **Programmable soft buttons**: User defined soft-buttons for selecting main video source, camera presets or speed dial.
- **Audio input levels**: Lets you see a visual overview of the audio input levels.
- **IP settings**: Lets you configure the IP settings.
- **Advanced configuration**: Lets you configure the system settings.
- **Change password**: Lets you change the menu password.

Chapter 4

The system settings menus



In this chapter...

- ▶ Explaining the system settings menus

The Advanced menus

Changes in the Advanced menu settings may affect the behavior of the system and should be configured by the system administrator.

How to change a value

- Select a value from a drop down list and press the OK button to save, or press the left arrow to leave without saving.
- Enter a value/text in a value/text field. Press Save to save the change or Cancel to leave without saving.

Description of each setting

Each of the settings in the Advanced configuration menu is explained in the Settings library section. Press the **Settings library** in the menu on top of the page to go to this section.

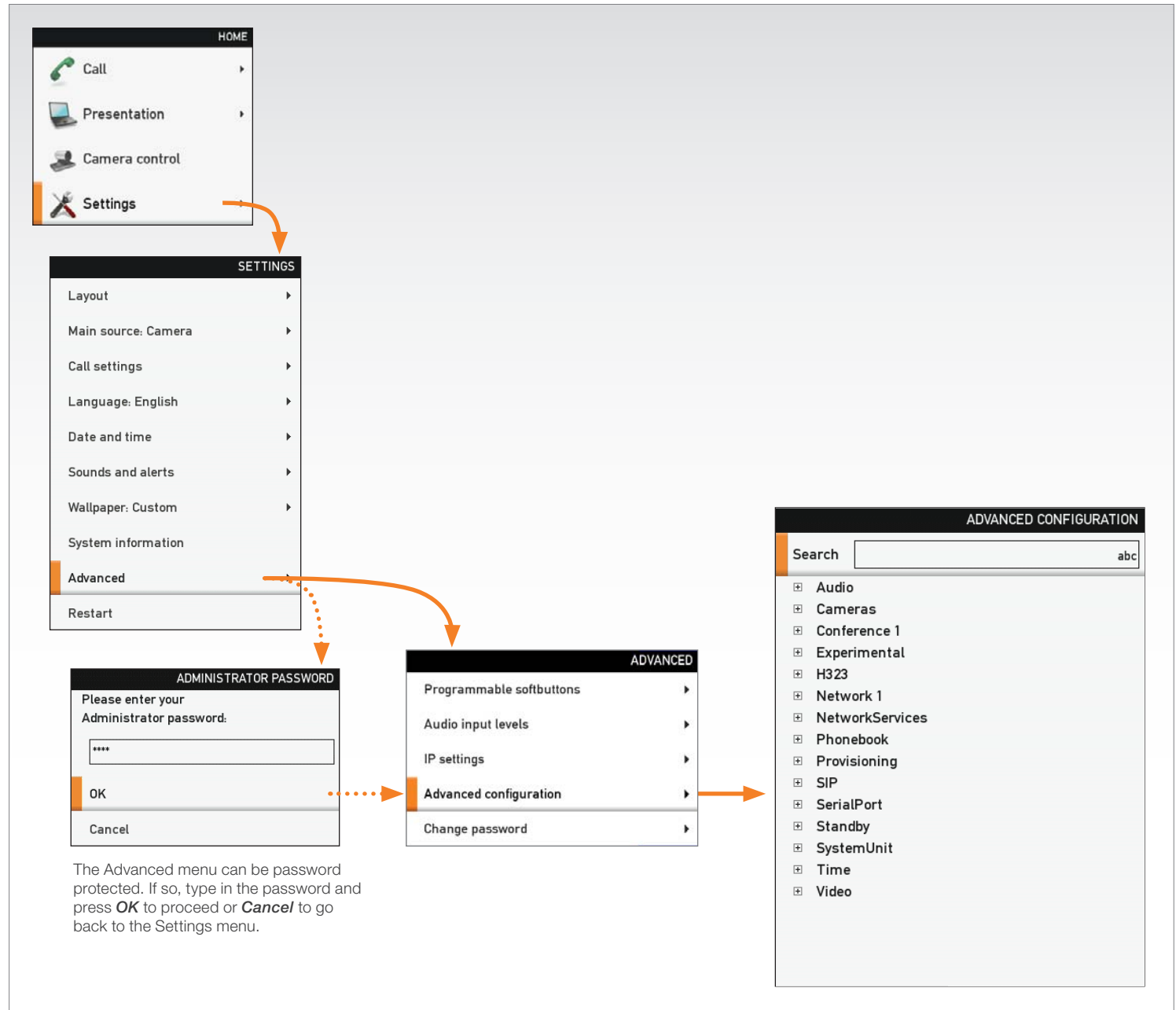

The Advanced menu can be password protected. If so, type in the password and press **OK** to proceed or **Cancel** to go back to the Settings menu.

The Advanced configuration menu

The Advanced configuration menu contains all the system settings, included the IP settings which also are available in the Advanced menu.

The search functionality

On the remote control, press the # key to toggle between lower or upper case characters and numbers: abc/ABC/123

When searching for words like "H323", "SIP" or "key", all settings with these characters in the name will be listed.

- **Search:** Enter the as many characters as needed until the setting you are searching for displays in the list.
- **Refine the search:** Add or remove characters until you get the desired result.
- **Clear:** Remove all characters to return to the main view.

Search

Enter the as many characters as needed, until the setting you are searching for displays in the list.

Example 1: Search for "sip" to see all the SIP settings.

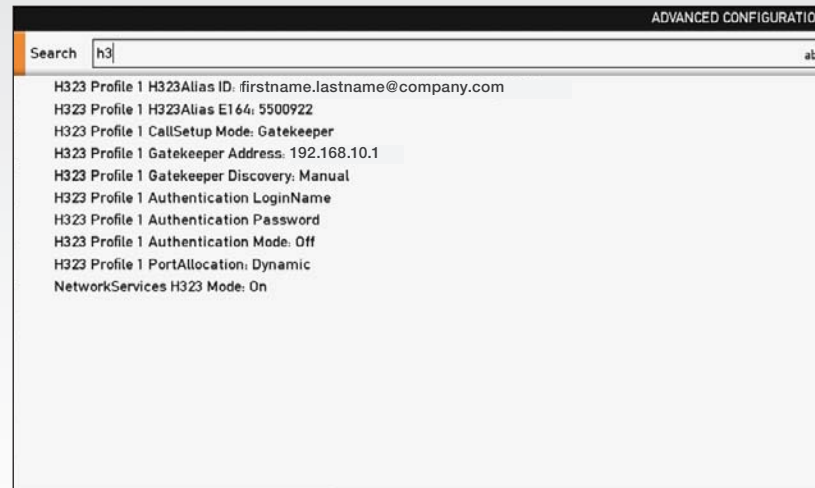

Example 2: Search for H323. In this case it is sufficient to enter "h3" to display all the H323 settings.

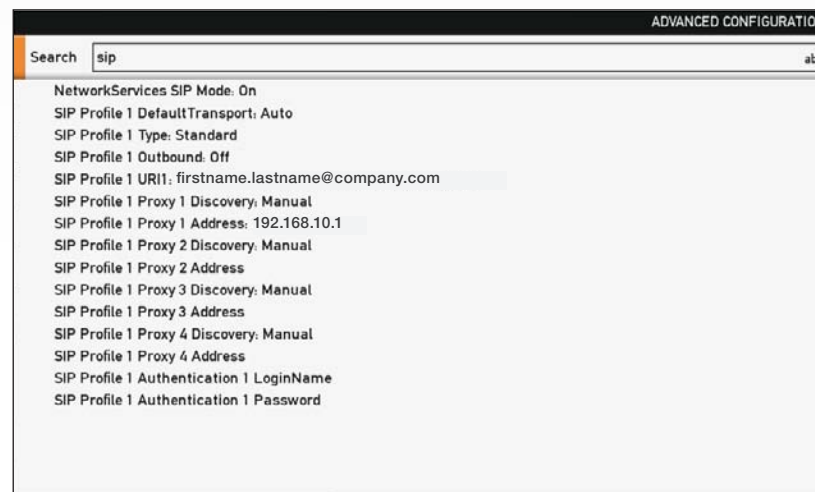

The Advanced menu

How to change the menu password

If a menu password has been set you will be asked to enter a password to get access to the Advanced menu.

When turning on the system for the first time, the password is not set.

NOTE! The menu password will only apply to the Advanced menu. The codec and the web interface can be password protected with an administrator password. See the [Password protection](#) section in the Appendices for a detailed description.



When you define or change a password make sure you save a copy of the password in a safe place.

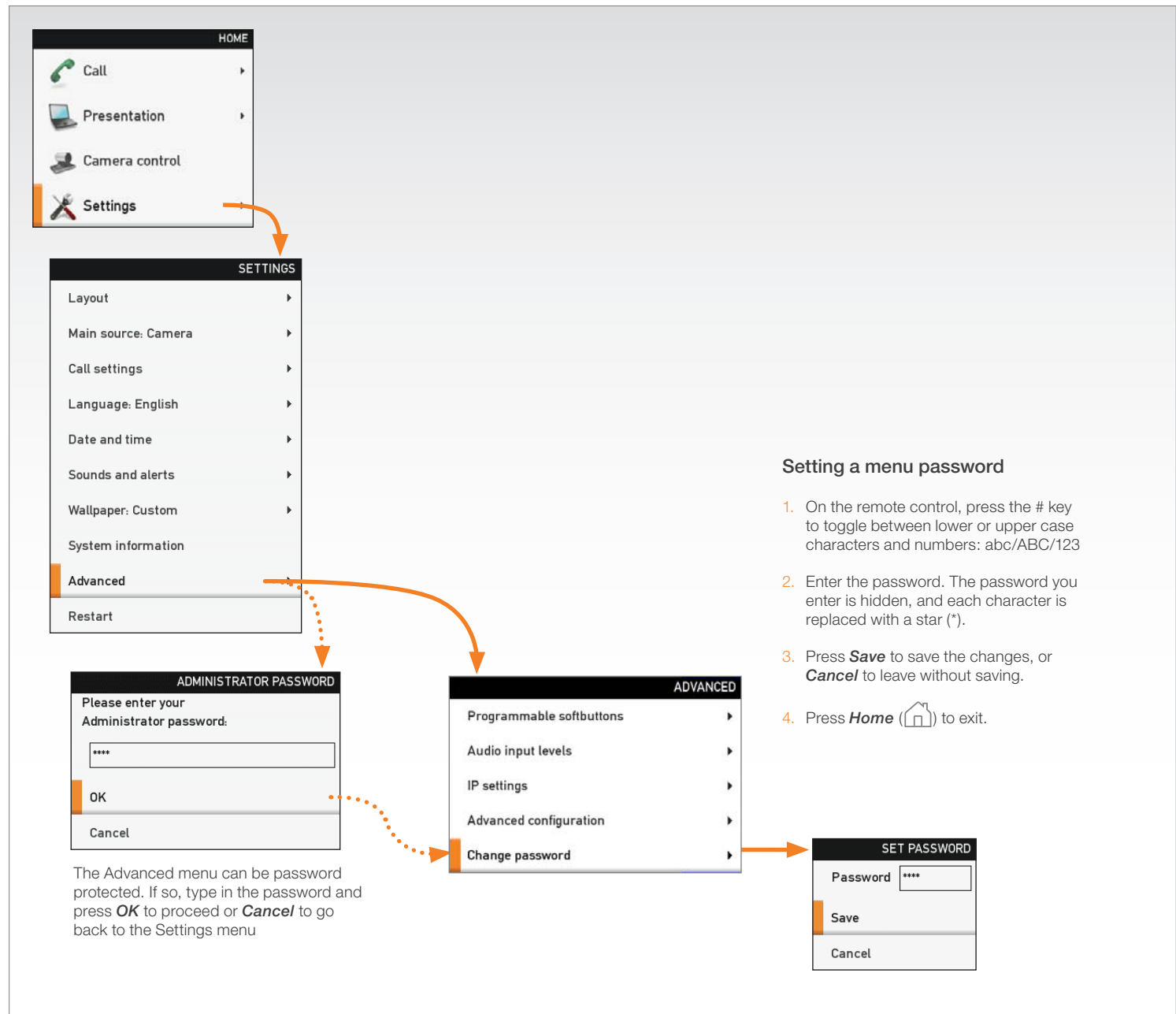

Setting a menu password

1. On the remote control, press the # key to toggle between lower or upper case characters and numbers: abc/ABC/123
2. Enter the password. The password you enter is hidden, and each character is replaced with a star (*).
3. Press **Save** to save the changes, or **Cancel** to leave without saving.
4. Press **Home** (house icon) to exit.

The Advanced menu can be password protected. If so, type in the password and press **OK** to proceed or **Cancel** to go back to the Settings menu

Chapter 5

The system settings library

This chapter gives a detailed description of the advanced system settings

The advanced settings defines the system settings and are structured in a hierarchy, making up a database of system settings.

Changes in the system settings may affect the system and should be done by the system administrator



In this chapter...

- ▶ Audio
- ▶ Cameras
- ▶ Conference
- ▶ H323 Profile
- ▶ Network
- ▶ Network Services
- ▶ Phone Book Server
- ▶ Provisioning
- ▶ Serial Port
- ▶ SIP Profile
- ▶ Standby
- ▶ System Unit
- ▶ Video
- ▶ Experimental

Description of the System settings

In the following pages you will find a complete list of the system settings. The examples shows either the default value or an example of a value.

All specifications are subject to change without prior notice.

We recommend you visit the TANDBERG web site regularly for updated versions of the manual.

Go to: ► <http://www.tandberg.com/docs>

The Audio settings

Audio Input HDMI [2..2] Level: <-24..0>

Defines the input level of HDMI input 2 in steps of 1dB from -24 dB to 0 dB.

See the Audio Level tables in the Codec C60 System Integrators Guide for a complete overview of the menu values represented in dB.

Range: -24 to 0 dB

Example: Audio Input HDMI 3 Level: 0

Audio Input HDMI [2..2] Mode: <On/Off>

Determines whether or not the two audio channels on the HDMI 2 input should be enabled.

On: Set to On to enable the audio channels on the HDMI 2 input.

Off: Set to Off to disable the audio channels on the HDMI 2 input.

Example: Audio Input HDMI 2 Mode: On

Audio Input Line [1..2] Channel: <Left/Right/Mono>

Defines whether the Audio Line input is a mono signal or part of a multichannel signal.

Left: The Audio Line input signal is the left channel of a stereo signal.

Right: The Audio Line input signal is the right channel of a stereo signal.

Mono: The Audio Line input signal is a mono signal.

Example: Audio Input 1 Channel: Left

Audio Input Line [1..2] Level: <0..24>

Defines the input level of each Line input in steps of 1dB from 0dB to 24 dB. Addresses the specific Audio Line input.

See the Audio Level tables in the Codec C60 System Integrators Guide for a complete overview of the menu values represented in dB.

Range: 0 to 24 dB

Example: Audio Input Line 1 Level: 10

Audio Input Line [1..2] LoopSuppression: <Off>

Loop suppression detects whether a delayed signal loop is present from an audio Line output to an audio Line input on the codec. If a loop is detected, this unwanted feedback is suppressed.

On: Set to On to activate Loop Suppression.

Off: Set to Off to deactivate Loop Suppression. Note! Codec C60 does currently not support Loop Suppression, hence Loop Suppression can be set to Off only.

Example: Audio Input Line 1 LoopSuppression: Off

Audio Input Line [1..2] Mode: <On/Off>

Determines whether or not an Audio Line input is enabled. Addresses the specific Audio Line input.

On: Set to On to enable the Audio Line input.

Off: Set to Off to disable the Audio Line input.

Example: Audio Input Line 1 Mode: On

Audio Input Microphone [1..4] EchoControl Mode: <On/Off>

The echo canceller continuously adjusts itself to the audio characteristics of the room and compensate for any changes it detects in the audio environment. If the changes in the audio conditions are very significant the echo canceller may take a second or two to re-adjust. Addresses the specific microphone.

On: Echo Control is normally set to On to prevent the far end from hearing their own audio. Once selected, echo cancellation is active at all times.

Off: Echo Control should be switched Off if external echo cancellation or playback equipment is used.

Example: Audio Input Microphone 1 EchoControl Mode: On

Audio Input Microphone [1..4] EchoControl NoiseReduction: <On/Off>

The system has a built-in noise reduction which reduces constant background noise (e.g. noise from air-conditioning systems, cooling fans etc.). In addition, a high pass filter (Humfilter) reduces very low frequency noise. Requires the Echo Control Mode to be enabled for the specified microphone. Addresses the specific microphone.

On: The Noise Reduction should be set to On in the presence of low frequency noise.

Off: Turns Noise Reduction Off for the specified microphone input.

Example: Audio Input Microphone 1 EchoControl NoiseReduction: On

Audio Input Microphone [1..4] Level: <0..24>

Defines the input level of each microphone in steps of 1dB from -24 dB to 0 dB. Addresses the specific microphone.

See the Audio Level tables in the Codec C60 System Integrators Guide for a complete overview of the menu values represented in dB.

Range: 0 to 24 dB

Example: Audio Input Microphone 1 Level: 14

The Audio settings, *continued...*

Audio Input Microphone [1..4] Mode: <On/Off>

Determines whether or not a microphone input is enabled. Addresses the specific microphone input.

On: Set to On to enable the microphone input.

Off: Set to Off to disable the microphone input.

Example: Audio Input Microphone 1 Mode: On

Audio Input Microphone [1..4] Type: <Microphone/Line>

The microphone inputs are intended for electret type microphones. The microphone input can be set to line or microphone mode. Addresses the specific microphone.

Microphone: 48 V Phantom voltage and pre-amplification is On

Line: Select Line when you have a standard balanced line input. The phantom voltage and pre-amplification is Off.

Example: Audio Input Microphone 1 Type: Line

Audio Output HDMI [1..1] Level: <-24..0>

Defines the output level of HDMI output 1 in steps of 1 dB from -24 dB to 0 dB.

See the Audio Level tables in the Codec C60 System Integrators Guide for a complete overview of the menu values represented in dB.

Range: -24 to 0 dB

Example: Audio Output HDMI 1 Level: 0

Audio Output HDMI [1..1] Mode: <On/Off>

Determines whether or not the audio channel on the HDMI output should be enabled.

On: Set to On to enable the audio channel on the HDMI 1 or HDMI 3 output.

Off: Set to On to disable the audio channel on the HDMI 1 or HDMI 3 output.

Example: Audio Output HDMI 1 mode: On

Audio Output Line [1..2] Channel: <Left/Right/Mono>

Defines whether the Audio Line output is a mono signal or part of a multichannel signal.

Left: The Audio Line output signal is the left channel of a stereo signal.

Right: The Audio Line output signal is the right channel of a stereo signal.

Mono: The Audio Line output signal is a mono signal.

Example: Audio Output Line 1 Channel: Left

The Audio settings, *continued...*

Audio Output Line [1..2] Level: <-24..0>

Defines the output level of the specified Audio Output Line in steps of 1 dB from -24 dB to 0 dB. Addresses the specific Audio Line output connector.

See the Audio Level tables in the Codec C60 System Integrator Guide for a complete overview of the menu values represented in dB.

Range: -24 to 0 dB

Example: Audio Output Line 1 Level: -10

Audio Output Line [1..2] Mode: <On/Off>

Determines whether or not an Audio Line output is enabled. Addresses the specific Audio Line output.

On: Set to On to enable the Audio Line output.

Off: Set to Off to disable the Audio Line output.

Example: Audio Output Line 1 Mode: On

Audio Output Line [1] Type: <Auto/SPDIF>

Determines if the Audio Line output is an analog or digital type output.

Auto: If a TANDBERG Digital NAM is detected then SPDIF mode will be selected, otherwise analog mode will be selected.

SPDIF: Set to SPDIF when you want the Audio Line 1 output to be in digital mode.

Example: Audio Output Line 1 Type: Auto

Audio Output Line [2] Type: <Analog>

Applies to Line 2: This is an analog output.

Example: Audio Output Line 1 Type: Analog

Audio SoundsAndAlerts KeyTones Mode: <On/Off>

The system can produce a sound every time a key on the remote control is pressed.

On: There will be a sound indicator when pressing keys on the remote control.

Off: The key tone on the remote control is switched off.

Example: Audio SoundsAndAlerts KeyTones Mode: Off

Audio SoundsAndAlerts RingTone: <Marbles/IceCrystals/Polaris/Alert/Discrete/Fantasy/Jazz/Nordic/Echo/Rhythmic>

Selects the ringtone for incoming calls.

Range: Select a tone from the list of ringtones.

Example: Audio SoundsAndAlerts RingTone: Jazz

The Audio settings, *continued...*

Audio SoundsAndAlerts RingVolume: <0..100>

Sets the ring tone volume[0-100] for an incoming call in steps of 0.5dB from -34.5dB to 15dB. Volume 0 = Off.

Example: Audio SoundsAndAlerts RingVolume: 50

Audio Volume: <0..100>

Sets the volume level [0-100] on the loudspeaker output in steps of 0.5dB from -34.5dB to 15dB. Volume 0 = Off.

Example: Audio Volume: 70

The Camera settings

Cameras Camera [1..7] Backlight: <On/Off>

Backlight is used to compensate for lights shining directly at the camera (usually the sun entering the window) to avoid a too dark image from the room. Addresses the specific camera.

On: Set to On to turn on the backlight compensation.

Off: Set to Off to turn the backlight compensation off.

Example: Cameras Camera 1 Backlight: Off

Cameras Camera [1..7] Brightness Level: <1..31>

Define the Brightness Level for the camera. Requires the Brightness Mode to be set to manual. Addresses the specific camera.

Range: 1-31

Example: Cameras Camera 1 Brightness Level: 1

Cameras Camera [1..7] Brightness Mode: <Auto/Manual>

Define whether to control the camera brightness manually or to have it automatically adjusted by the system. Addresses the specific camera.

Auto: When set to Auto, the camera brightness is automatically set by the system.

Manual: Set to Manual to enable manual control of the camera brightness, e.g. the level of the brightness level setting will be used for the camera.

Example: Cameras Camera 1 Brightness Mode: Auto

The Camera settings, *continued...*

Cameras Camera [1..7] Flip: <On/Off>

Applies to cameras which supports Flip mode. Enables the video on screen to be flipped upside down. Addresses the specific camera. Since TANDBERG PrecisionHD 1080p camera auto-detects if the camera is mounted upside down, the flip mode is not necessary to use for this camera.

On: When set to On the video on screen is flipped. This setting is used with cameras that can be mounted upside down, but cannot auto detect that the camera is mounted upside down.

Off: Set to Off to display the video on screen the normal way.

Example: Cameras Camera 1 Flip: Off

Cameras Camera [1..7] Focus Mode: <Auto/Manual>

Determines whether the camera should be in auto focus or manual focus mode. Addresses the specific camera.

Auto: When set to Auto the focus will be updated throughout the call. When moving the camera, the system will use auto focus for a few seconds to set the right focus of the new camera position. After a few seconds auto focus is turned off to prevent continuous focus adjustments of the camera.

Manual: If set to Manual the focus is adjusted manually.

Example: Cameras Camera 1 Focus Mode: Auto

Cameras Camera [1..7] Gamma Level: <0..7>

By setting the Gamma Level you can select which gamma correction table to use. This setting may be useful in difficult lighting conditions, where changes to the the brightness setting does not provide satisfactory results. Requires the Gamma Mode to be set to Manual. Addresses the specific camera.

Range: 0-7

Example: Cameras Camera 1 Gamma Level: 0

Cameras Camera [1..7] Gamma Mode: <Auto/Manual>

Applies to cameras which supports Gamma mode. The Gamma Mode setting enables for gamma corrections. Gamma describes the nonlinear relationship between image pixels and monitor brightness. Addresses the specific camera. The TANDBERG PrecisionHD 1080p camera do not need Gamma Mode. The TANDBERG PrecisionHD 720p camera do support Gamma Mode.

Auto: Auto is the default and the recommended setting.

Manual: In severe light conditions, you may switch mode to manual and specify explicitly which gamma table to use by setting the Gamma Level.

Example: Cameras Camera 1 Gamma Mode: Auto

The Camera settings, *continued...*

Cameras Camera [1..7] IrSensor: <On/Off>

The Camera IR setting determines whether the infrared receiver at the camera should be enabled or not. The IR sensor LED is located in the front of the camera and flickers when the IR sensor is activated from the remote control. Addresses the specific camera.

On: Set to On to enable the IR sensor on the camera.

Off: Set to Off to disable the IR sensor on the camera.

Example: Cameras Camera 1 IrSensor: On

Cameras Camera [1..7] Mirror: <On/Off>

The Mirror mode makes it possible to reverse the the video on screen. Normally you will see yourself in the same view as other people sees you. With mirror enabled the experience will be like looking at yourself in a mirror. Addresses the specific camera.

On: Set to On to see the selfview in mirror mode, e.g. the selfview is reversed and the experience of selfview is as seeing yourself in a mirror.

Off: Set to Off to see the selfview in normal mode, e.g. the experience of selfview is as seeing yourself as other people see you.

Example: Cameras Camera 1 Mirror: Off

Cameras Camera [1..7] Whitebalance Level: <1..16>

Specify which camera to control. Define the Whitebalance Level for the camera. Requires the Whitebalance Mode to be set to manual. Addresses the specific camera.

Range: 1-16

Example: Cameras Camera 1 Whitebalance Level: 1

Cameras Camera [1..7] Whitebalance Mode: <Auto/Manual>

Define whether to control the camera whitebalance manually or to have it automatically adjusted by the system. Addresses the specific camera.

Auto: When set to Auto, the camera will continuously adjust the whitebalance depending on the camera view.

Manual: Set to Manual to enable manual control of the camera whitebalance, e.g. the level of the whitebalance level setting will be used for the camera.

Example: Cameras Camera 1 Whitebalance Mode: auto

The Conference settings

Conference [1..1] AutoAnswer Delay: <0..50>

Defines how long (in seconds) an incoming call has to wait before it is answered automatically by the system. Requires the Autoanswer Mode to be enabled.

Range: 0-50 seconds

Example: Conference 1 AutoAnswer Delay: 0

Conference [1..1] AutoAnswer Mode: <On/Off>

The Autoanswer setting determines whether an incoming call is put through automatically or manually.

On: The system will automatically answer all incoming calls.

Off: All incoming call must be answered manually by pressing the OK key or the green Call key on the remote control.

Example: Conference 1 AutoAnswer Mode: Off

Conference [1..1] AutoAnswer Mute: <On/Off>

The Autoanswer Mute setting determines whether the microphone is muted when an incoming call is automatically answered.

On: The incoming call will be muted when automatically answered.

Off: The incoming call will not be muted.

Example: Conference 1 AutoAnswer Mute: Off

Conference [1..1] DefaultCall Protocol: <H323/SIP>

Specify the Default Call Protocol to be used when placing calls from the system. The call protocol can also be defined directly for each call when setting up a call.

H.323: Select H.323 to ensure that calls are set up as a H.323 calls.

SIP: Select SIP to ensure that calls are set up as a SIP calls.

Example: Conference 1 DefaultCall Protocol: H323

Conference [1..1] DefaultCall Rate: <64..6000>

Specify the Default Call Rate to be used when placing calls from the system. The call rate can also be defined directly for each call when setting up a call.

Range: 64-6000 kbps

Example: Conference 1 DefaultCall Rate: 768

The Conference settings, *continued...*

Conference [1..1] DoNotDisturb Mode: <On/Off>

The Do Not Disturb setting determines whether or not there should be an alert on incoming calls.

On: Set to On when you want no alert to incoming calls. The calling side will receive a busy signal when trying to call the codec.

Off: This is the default setting. The DoNotDisturb is automatically turned Off if the codec receives any IR signal from the handheld remote control.

Example: DoNotDisturb Mode: Off

Conference [1..1] Encryption Mode: <Off/BestEffort>

BestEffort: The system will use encryption whenever possible.

In Point to point calls: If the far end system supports encryption (AES-128), the call will be encrypted. If not, the call will proceed without encryption.

In MultiSite calls: In order to have encrypted MultiSite conferences, all sites must support encryption. If not, the conference will be unencrypted.

Icons on screen: A padlock with the text "Encryption On" displays on screen, for a few seconds, when the conference starts.

Off: The system will not use encryption.

Example: Conference 1 Encryption Mode: BestEffort

Conference [1..1] FarEndControl Mode: <On/Off>

Lets you decide if the remote side (far end) should be allowed to select your video sources and control your local camera (pan, tilt, zoom).

On: Set to On when you want the the far end to be able to select your video sources and control your local camera (pan, tilt, zoom). You will still be able to control your camera and select your video sources as normal.

Off: When set to Off the far end can not access any of the features above on your system.

Example: Conference 1 FarEndControl Mode: On

Conference [1..1] IncomingMultisiteCall Mode: <Allow/Deny>

The Incoming Multisite Call setting determines whether or not the system should accept incoming calls to an already active conference.

Allow: When set to Allow, and with an ongoing MCU call/conference, the user can accept another incoming call. This will result in the incoming call being added to the MCU conference.

Deny: The system will not accept incoming calls when you are in a call. The calling side will receive a busy signal.

Example: Conference 1 IncomingMultisiteCall Mode: Allow

The H323 Profile settings

H323 Profile [1..1] Authentication LoginName: <S: 0, 50>

The system sends the Authentication Login Name and the Authentication Password to a H.323 Gatekeeper for authentication. The authentication is a one way authentication from the codec to the H.323 Gatekeeper, i.e. the system is authenticated to the gatekeeper. If the H.323 Gatekeeper indicates that no authentication is required, the system will still try to register. Requires the H.323 Gatekeeper Authentication Mode to be enabled.

Format: String with a maximum of 50 characters.

Example: H323 Profile 1 Authentication LoginName: ""

H323 Profile [1..1] Authentication Password: <S: 0, 50>

The system sends the Authentication Login Name and the Authentication Password to a H.323 Gatekeeper for authentication. The authentication is a one way authentication from the codec to the H.323 Gatekeeper, i.e. the system is authenticated to the gatekeeper. If the H.323 Gatekeeper indicates that no authentication is required, the system will still try to register. Requires the H.323 Gatekeeper Authentication Mode to be enabled.

Format: String with a maximum of 50 characters.

Example: H323 Profile 1 Authentication Password:

H323 Profile [1..1] Authentication Mode: <On/Off>

On: If the H.323 Gatekeeper Authentication Mode is set to On and a H.323 Gatekeeper indicates that it requires authentication, the system will try to authenticate itself to the gatekeeper. Requires the Authentication ID and Authentication Password to be defined on both the codec and the Gatekeeper.

Off: If the H.323 Gatekeeper Authentication Mode is set to Off the system will not try to authenticate itself to a H.323 Gatekeeper, but will still try a normal registration.

Example: H323 Profile 1 Authentication Mode: Off

H323 Profile [1..1] CallSetup Mode: <Direct/Gatekeeper>

The H.323 Call Setup Mode defines whether to use a Gatekeeper or Direct calling when establishing H323 calls.

Direct: An IP-address must be used when dialling in order to make the H323 call.

Gatekeeper: The system will use a Gatekeeper to make a H.323 call. When selecting this option the H323 Profile Gatekeeper Address and H323 Profile Gatekeeper Discovery settings must also be configured.

NOTE! Direct H.323 calls can be made even though the H.323 Call Setup Mode is set to Gatekeeper.

Example: H323 Profile 1 CallSetup Mode: Gatekeeper

H323 Profile [1..1] Gatekeeper Address: <S: 0, 64>

Specifies the IP address of the Gatekeeper. Requires the H.323 Call Setup Mode to be set to Gatekeeper and the Gatekeeper Discovery to be set to Manual.

Format: String with a maximum of 64 characters.

Example: H323 Profile 1 Gatekeeper Address: "10.47.1.58"

The H323 Profile settings, *continued...*

H323 Profile [1..1] Gatekeeper Discovery: <Manual/Auto>

Determines how the system shall register to a H.323 Gatekeeper.

Manual: The system will use a specific Gatekeeper identified by the Gatekeeper's IP-address.

Auto: The system will automatically try to register to any available Gatekeeper. If a Gatekeeper responds to the request sent from the codec within 30 seconds this specific Gatekeeper will be used. This requires that the Gatekeeper is in auto discovery mode as well. If no Gatekeeper responds, the system will not use a Gatekeeper for making H.323 calls and hence an IP-address must be specified manually.

Example: H323 Profile 1 Gatekeeper Discovery: Manual

H323 Profile [1..1] H323Alias E164: <S: 0, 30>

The H.323 Alias E.164 defines the address of the system, according to the numbering plan implemented in the H.323 Gatekeeper. The E.164 alias is equivalent to a telephone number, sometimes combined with access codes.

Format: Compact string with a maximum of 30 characters. Valid characters are 0–9, * and #.

Example: H323 Profile 1 H323Alias E164: "90550092"

H323 Profile [1..1] H323Alias ID: <S: 0, 49>

Lets you specify the H.323 Alias ID which is used to address the system on a H.323 Gatekeeper and will be displayed in the call lists. Example: "firstname.surname@company.com", "My H.323 Alias ID"

Format: String with a maximum of 49 characters

Example: H323 Profile 1 H323Alias ID: "firstname.surname@company.com"

H323 Profile [1..1] PortAllocation: <Dynamic/Static>

The H.323 Port Allocation setting affects the H.245 port numbers used for H.323 call signalling.

Dynamic: The system will allocate which ports to use when opening a TCP connection. The reason for doing this is to avoid using the same ports for subsequent calls, as some firewalls consider this as a sign of attack. When Dynamic is selected, the H.323 ports used are from 11000 to 20999. Once 20999 is reached they restart again at 11000. For RTP and RTCP media data, the system is using UDP ports in the range 2326 to 2487. Each media channel is using two adjacent ports, ie 2330 and 2331 for RTP and RTCP respectively. The ports are automatically selected by the system within the given range. Firewall administrators should not try to deduce which ports are used when, as the allocation schema within the mentioned range may change without any further notice.

Static: When set to Static the ports are given within a static predefined range [5555–6555].

Example: H323 Profile 1 PortAllocation: Dynamic

The Network settings

Network [1..1] Assignment: <Static/DHCP>

Defines whether to use DHCP or Static IP assignment.

Static: The IP Address, Subnet Mask and Default Gateway for the system must be specified in the respective address fields.

DHCP: The system addresses are automatically assigned by the DHCP server.

Changes to this setting requires a restart of the codec.

Example: Network 1 Assignment: DHCP

Network [1..1] DNS Domain Name: <S: 0, 64>

DNS Domain Name is the default domain name suffix which is added to unqualified names.

Example: If the DNS Domain Name is "company.com" and the name to lookup is "MyVideoSystem", this will result in the DNS lookup "MyVideoSystem.company.com".

Format: String with a maximum of 64 characters.

Example: Network 1 DNS Domain Name: "company.com"

Network [1..1] DNS Server [1..5] Address: <S: 0, 64>

Defines the network addresses for DNS servers. Up to 5 addresses may be specified. If the network addresses are unknown, please contact your administrator or Internet Service Provider.

Format: String with a maximum of 64 characters.

Example: Network 1 DNS Server 1 Address: ""

Network [1..1] IEEE8021X AnonymousIdentity: <S: 0, 64>

The 802.1X Anonymous ID string is to be used as unencrypted identity with EAP types that support different tunneled identity, like EAP-PEAP and EAP-TTLS. If set, the anonymous ID will be used for the initial (unencrypted) EAP Identity Request.

Format: String with a maximum of 64 characters.

Example: Network 1 IEEE8021X AnonymousIdentity: ""

Network [1..1] IEEE8021X Eap Md5: <On/Off>

Message-Digest algorithm 5. Is a Challenge Handshake Authentication Protocol that relies on a shared secret. MD5 is a Weak security. EAP - Extensible Authentication Protocol. MD5 - Message Digest Algorithm 5.

On: The EAP-MD5 protocol is enabled. Default mode is On.

Off: The EAP-MD5 protocol is disabled.

Example: Network 1 IEEE8021X Eap Md5: On

The Network settings, *continued...*

Network [1..1] IEEE8021X Eap Peap: <On/Off>

Protected Transport Layer Security. Developed by Microsoft, Cisco and RSA Security. Authenticates LAN clients without the need for client certificates. EAP - Extensible Authentication Protocol. PEAP - Protected Extensible Authentication Protocol.

On: The EAP-PEAP protocol is enabled. Default mode is On.

Off: The EAP-PEAP protocol is disabled.

Example: Network 1 IEEE8021X Eap Peap: On

Network [1..1] IEEE8021X Eap TTLS: <On/Off>

Tunneled Transport Layer Security. Developed by Funk Software and Certicom. Usually supported by Agere Systems, Proxim and Avaya. Authenticates LAN clients without the need for client certificates. EAP - Extensible Authentication Protocol. TTLS - Tunneled Transport Layer Security.

On: The EAP-TTLS protocol is enabled. Default mode is On.

Off: The EAP-TTLS protocol is disabled.

Example: Network 1 IEEE8021X Eap TTLS: On

Network [1..1] IEEE8021X Identity: <S: 0, 64>

The 802.1X Identity is the user name needed for 802.1X authentication.

Format: String with a maximum of 64 characters.

Example: Network 1 IEEE8021X Identity: ""

Network [1..1] IEEE8021X Mode: <On/Off>

The system may be connected to an IEEE 802.1X LAN network with a port-based network access control that is used to provide authenticated network access for Ethernet networks.

On: The 802.1X authentication is enabled.

Off: The 802.1X authentication is disabled. Default mode is Off.

Example: Network 1 IEEE8021X Mode: Off

Network [1..1] IEEE8021X Password: <S: 0, 32>

The 802.1X Password is the password needed for 802.1X authentication.

Format: String with a maximum of 32 characters.

Example: Network 1 IEEE8021X Password: ""

Network [1..1] IPv4 Address: <S: 0, 64>

Defines the Static IP address for the system. Only applicable if Static IP assignment is chosen.

Format: Compact string with a maximum of 64 characters.

Example: Network 1 IPv4 Address: "10.47.5.100"

The Network settings, *continued...*

Network [1..1] IPv4 Gateway: <S: 0, 64>

Defines the IP default gateway. Only applicable if Static IP assignment is chosen.

Format: Compact string with a maximum of 64 characters.

Example: Network 1 IPv4 Gateway: "10.47.5.100"

Network [1..1] IPv4 SubnetMask: <S: 0, 64>

Defines the IP subnet mask. Only applicable if Static IP assignment is chosen.

Format: Compact string with a maximum of 64 characters.

Example: Network 1 IPv4 SubnetMask: "255.255.255.0"

Network [1..1] IPv4 QoS Mode: <Off/Diffserv>

Defines whether IP Diffserv QoS should be used. The QoS (Quality of Service) is a method which handles the priority of audio, video and data in the network. The QoS settings must be supported by the infrastructure. DiffServ (Differentiated Services) is a computer networking architecture that specifies a simple, scalable and coarse-grained mechanism for classifying, managing network traffic and providing QoS priorities on modern IP networks.

Off: When set to Off no QoS method is used.

Diffserv: Select Diffserv and then go to the Diffserv sub-menus (Audio, Data, Signalling and Video) to configure these settings.

Example: Network 1 IPv4 QoS Mode: diffserv

Network [1..1] IPv4 QoS Diffserv Audio: <0..63>

The DiffServ Audio setting is used to define which priority Audio packets should have in an IP network. Enter a priority, which ranges from 0 to 63 for the packets. The higher the number, the higher the priority. These priorities might be overridden when packets are leaving the network controlled by the local network administrator.

Audio: A recommended value is DiffServ Code Point (DSCP) is AF41, which equals the value 34. If in doubt, contact your network administrator. Range: 0-63

Example: Network 1 IPv4 QoS Diffserv Audio: 0

Network [1..1] IPv4 QoS Diffserv Data: <0..63>

The DiffServ Data setting is used to define which priority Data packets should have in an IP network. Enter a priority, which ranges from 0 to 63 for the packets. The higher the number, the higher the priority. These priorities might be overridden when packets are leaving the network controlled by the local network administrator.

Data: A recommended value is DiffServ Code Point (DSCP) AF23, which equals the value 22. If in doubt, contact your network administrator. Range: 0-63

Example: Network 1 IPv4 QoS Diffserv Data: 0

The Network settings, *continued...*

Network [1..1] IPv4 QoS Diffserv Signalling: <0..63>

The DiffServ Signalling setting is used to define which priority Signalling packets should have in an IP network. Enter a priority, which ranges from 0 to 63 for the packets. The higher the number, the higher the priority. These priorities might be overridden when packets are leaving the network controlled by the local network administrator.

Signalling: A recommended value is DiffServ Code Point (DSCP) AF31 which equals the value 26. If in doubt, contact your network administrator.

Range: 0-63

Example: Network 1 IPv4 QoS Diffserv Signalling: 0

Network [1..1] IPv4 QoS Diffserv Video: <0..63>

The DiffServ Video setting is used to define which priority Video packets should have in an IP network. Enter a priority, which ranges from 0 to 63 for the packets. The higher the number, the higher the priority. These priorities might be overridden when packets are leaving the network controlled by the local network administrator.

Video: A recommended value is DiffServ Code Point (DSCP) AF41, which equals the value 34. If in doubt, contact your network administrator.

Range: 0-63

Example: Network 1 IPv4 QoS Diffserv Video: 0

Network [1..1] MTU: <400..1500>

Set the ethernet MTU (Maximum Transmission Unit).

Range: 400-1500

Example: Network 1 MTU: 1500

Network [1..1] Speed: <Auto/10half/10full/100half/100full/1000full>

Set the ethernet link speed.

Auto: Autonegotiate link speed.

10half: Force link to 10Mbps half-duplex.

10full: Force link to 10Mbps full-duplex.

100half: Force link to 100Mbps half-duplex.

100full: Force link to 100Mbps full-duplex.

1000full: Force link to 1Gbps full-duplex.

Example: Network 1 Speed: Auto

The Network settings, *continued...*

Network [1..1] TrafficControl Mode: <On/Off>

Configure how video packets transmission speed shall be controlled.

On: Transmit video packets at maximum 20Mbps. Can be used to smooth out bursts in the outgoing network traffic.

Off: Transmit video packets at link speed.

Example: Network 1 TrafficControl: On

The Network Services settings

NetworkServices H323 Mode: <On/Off>

Determines whether the system should be able to place and receive H.323 calls.

On: Set to On to enable the possibility to place and receive H.323 calls. This is the default setting.

Off: Set to Off to disable the possibility to place and receive H.323 calls.

NOTE! Changes in this setting requires the codec to be restarted.

Example: NetworkServices H323 Mode: On

NetworkServices HTTP Mode: <On/Off>

HTTP is a web-interface for system management, call management such as call transfer, diagnostics and software uploads.

On: The HTTP protocol is enabled.

Off: The HTTP protocol is disabled.

Example: NetworkServices HTTP Mode: On

NetworkServices HTTPS Mode: <On/Off>

HTTPS is a Web protocol that encrypts and decrypts user page requests as well as the pages that are returned by the Web server.

On: The HTTPS protocol is enabled.

Off: The HTTPS protocol is disabled.

Example: NetworkServices HTTPS Mode: On

NetworkServices NTP Address: <S: 0, 64>

Enter the NTP Address to define the network time protocol server address. This address will be used if NTP Mode is set to Manual, or if set to Auto and no address is supplied by a DHCP server.

Format: String with a maximum of 64 characters.

Example: NetworkServices NTP Address: "1.tandberg.pool.ntp.org"

The Network Services settings, *continued...*

NetworkServices NTP Mode: <Auto/Manual>

The Network Time Protocol (NTP) is used to synchronize the time of the system to a reference time server. The time server will subsequently be queried every 24th hour for time updates. The time will be displayed on the top of the screen. The system will use the time to timestamp messages transmitted to Gatekeepers or Border Controllers requiring H.235 authentication. The system will use the time to timestamp messages transmitted to Gatekeepers or Border Controllers that requires H.235 authentication. It is also used for timestamping Placed Calls, Missed Calls and Received Calls.

Auto: The system will use the NTP server, by which address is supplied from the DHCP server in the network. If no DHCP server is used, or the DHCP server does not provide the system with a NTP server address, the system will use the static defined NTP server address specified by the user.

Manual: The system will always use the static defined NTP server address specified by the user.

Example: NetworkServices NTP Mode: Manual

NetworkServices SIP Mode: <On/Off>

Determines whether the system should be able to place and receive SIP calls.

On: Set to On to enable the possibility to place and receive SIP calls. This is the default setting.

Off: Set to Off to disable the possibility to place and receive SIP calls.

NOTE! Changes in this setting requires the codec to be restarted.

Example: NetworkServices SIP Mode: On

NetworkServices SNMP CommunityName: <S: 0, 50>

Enter the name of the Network Services SNMP Community. SNMP Community names are used to authenticate SNMP requests. SNMP requests must have a 'password' (case sensitive) in order to receive a response from the SNMP Agent in the codec. The default password is "public". If you have the TANDBERG Management Suite (TMS) you must make sure the same SNMP Community is configured there too. Note! The SNMP Community password is case sensitive.

Format: String with a maximum of 50 characters.

Example: NetworkServices SNMP CommunityName: "public"

NetworkServices SNMP Host [1..3] Address: <S: 0, 64>

Enter the address of up to three SNMP Managers. All traps will then be sent to the hosts listed.

The system's SNMP Agent (in the codec) responds to requests from SNMP Managers (a PC program etc.). SNMP Traps are generated by the SNMP Agent to inform the SNMP Manager about important events. Can be used to send event created messages to the SNMP agent about different events like: system reboot, system dialing, system disconnecting, MCU call, packet loss etc. Traps can be sent to multiple SNMP Trap Hosts.

Format: String with a maximum of 64 characters.

Example: NetworkServices SNMP Host 1 Address: ""

The Network Services settings, *continued...*

NetworkServices SNMP Mode: <Off/ReadOnly/ReadWrite>

SNMP (Simple Network Management Protocol) is used in network management systems to monitor network-attached devices (routers, servers, switches, projectors, etc) for conditions that warrant administrative attention. SNMP exposes management data in the form of variables on the managed systems, which describe the system configuration. These variables can then be queried (set to ReadOnly) and sometimes set (set to ReadWrite) by managing applications.

Off: Set to Off when you want to disable the SNMP network service.

ReadOnly: Set to ReadOnly when you want to enable the SNMP network service for queries only.

ReadWrite: Set to ReadWrite when you want to enable the SNMP network service for both queries and commands.

Example: NetworkServices SNMP Mode: ReadWrite

NetworkServices SNMP SystemContact: <S: 0, 50>

Enter the name of the Network Services SNMP System Contact.

Format: String with a maximum of 50 characters.

Example: NetworkServices SNMP SystemContact: ""

NetworkServices SNMP SystemLocation: <S: 0, 50>

Enter the name of the Network Services SNMP System Location.

Format: String with a maximum of 50 characters.

Example: NetworkServices SNMP SystemLocation: ""

NetworkServices Telnet Mode: <On/Off>

Telnet is a network protocol used on the Internet or local area network (LAN) connections.

On: The Telnet protocol is enabled.

Off: The Telnet protocol is disabled. This is the default factory setting.

Example: NetworkServices Telnet Mode: Off

The Phonebook settings

Phonebook Server [1..5] ID: <S: 0, 64>

Enter a name for the external phonebook. Addresses the specific phonebook.

Format: String with a maximum of 64 characters.

Example: Phonebook Server 1 ID: ""

Phonebook Server [1..5] URL: <S: 0, 255>

Enter the address (URL) to the external phonebook server. Addresses the specific phonebook server.

Format: String with a maximum of 255 characters.

Example: Phonebook Server 1 URL: "http://tms.company.com/tms/public/external/phonebook/phonebook.asmx"

The Provisioning settings

Provisioning ExternalManager Address: <S: 0, 64>

Specifies the IP Address to the External Manager/Management system. If an External Manager address and a path is configured, the system will post an HTTP message to this address when starting up. When receiving this HTTP posting the External Manager (typically a management system) can return configurations/commands to the unit as a result. If the DHCP Option 242 is returned in the DHCP response from the DHCP server the system will interpret this as the External Manager address to use.

Format: String with a maximum of 64 characters.

Example: Provisioning ExternalManager Address: ""

Provisioning ExternalManager Path: <S: 0, 255>

Specifies the path to the External Manager/Management system. If an External Manager address and a path is configured, the system will post an HTTP message to this address when starting up. When receiving this HTTP posting the External Manager (typically a management system) can return configurations/commands to the unit as a result. If the DHCP Option 242 is returned in the DHCP response from the DHCP server the system will interpret this as the External Manager address to use.

Format: String with a maximum of 255 characters.

Example: Provisioning ExternalManager Path: "tms/public/external/management/SystemManagementService.asmx"

The Provisioning settings, *continued...*

Provisioning Mode: <Off/TMS>

Provides the possibility of managing the codec (endpoint) by using an external manager/management system.

Off: The system will not try to register to any management system.

TMS: If set to TMS the system will try to register with a TMS server as described in Provisioning ExternalManager settings. TMS is short for TANDBERG Management System. Please contact your TANDBERG representative for more information.

Example: Provisioning Mode: TMS

The Serial Port settings

SerialPort BaudRate: <9600/19200/38400/57600/115200>

Specify the baud rate (bps) on the COM port (data port). The default value is 38400.

Other default parameters for the COM port are: Parity: None Databits: 8 Stopbits: 1 Flow control: None.

Valid inputs for baud rate: 9600, 19200, 38400, 57600, 115200 bits/second.

Example: SerialPort BaudRate: 38400

SerialPort LoginRequired: <On/Off>

The Serial Login setting determines whether or not there should be a login when connecting to the COM port (data port).

On: Login is required when connecting to the COM port (data port).

Off: The user can access the COM port (data port) without any login.

Example: SerialPort LoginRequired: On

The SIP Profile settings

SIP Profile [1..1] Authentication [1..1] LoginName: <S: 0, 50>

This is the user name part of the credentials used to authenticate towards the SIP proxy.

Format: String with a maximum of 50 characters.

Example: SIP Profile 1 Authentication 1 LoginName: ""

SIP Profile [1..1] Authentication [1..1] Password: <S: 0, 50>

This is the password part of the credentials used to authenticate towards the SIP proxy.

Format: String with a maximum of 50 characters.

Example: SIP Profile 1 Authentication 1 Password:

SIP Profile [1..1] DefaultTransport: <UDP/TCP/TLS/Auto>

Select the transport protocol to be used over the LAN.

UDP: The system will always use UDP as the default transport method.

TCP: The system will always use TCP as the default transport method.

TLS: The system will always use TLS as the default transport method. For TLS connections a SIP CA-list can be uploaded using the web interface. If no such CA-list is available on the system then anonymous Diffie Hellman will be used.

Auto: The system will try to connect using transport protocols in the following order: TLS, TCP, UDP.

Example: SIP Profile 1 DefaultTransport: Auto

SIP Profile [1..1] Outbound: <On/Off>

The client initiated connections mechanism for firewall traversal, connection reuse and redundancy. The current version supports <http://tools.ietf.org/html/draft-ietf-sip-outbound-20>.

On: Set up multiple outbound connections to servers in the Proxy Address list.

Off: Connect to the single proxy configured first in Proxy Address list.

Example: SIP Profile 1 Outbound: Off

SIP Profile [1..1] Proxy [1..4] Address: <S: 0, 255>

The Proxy Address is the manually configured address for the outbound proxy. It is possible to use a fully qualified domain name, or an IP address. The default port is 5060 for TCP and UDP but another one can be provided. If Outbound is enabled, multiple proxies can be addressed.

Format: Compact string with a maximum of 255 characters.

Example: SIP Profile 1 Proxy 1 Address: ""

The SIP Profile settings, *continued...*

SIP Profile [1..1] Proxy [1..4] Discovery: <Auto/Manual>

Manual: When Manual is selected, the manually configured SIP Proxy address will be used

Auto: When Auto is selected, the SIP Proxy address is obtained using Dynamic Host Configuration Protocol (DHCP).

Example: SIP Profile 1 Proxy 1 Discovery: Manual

SIP Profile [1..1] Type: <Standard/Alcatel/Avaya/Cisco/Microsoft/Nortel/Experimental/Siemens>

Enables SIP extensions and special behaviour for a vendor or provider

Standard: Should be used when registering to standard SIP proxy like OpenSer.

Alcatel: Must be used when registering to a Alcatel-Lucent OmniPCX Enterprise R7 or later.

Avaya: Must be used when registered to a Avaya Communication Manager.

Cisco: Must be used when registering to a Cisco CallManager version 5 or later.

Microsoft: Must be used when registering to a Microsoft LCS or OCS server.

Nortel: Must be used when registering to a Nortel MCS 5100 or MCS 5200 PBX.

Experimental: Can be used if auto is not working Note! This mode is for testing purposes only.

Example: SIP Profile 1 Type: Standard

SIP Profile [1..1] URI: <S: 0, 255>

The SIP URI or number is used to address the system. This is the URI that is registered and used by the SIP services to route inbound calls to the system. A Uniform Resource Identifier (URI) is a compact string of characters used to identify or name a resource.

Format: Compact string with a maximum of 255 characters.

Example: SIP Profile 1 URI: "sip:name@example.com"

The Standby settings

Standby BootAction: <None/Preset1/Preset2/Preset3/Preset4/Preset5/Preset6/Preset7/Preset8/Preset9/Preset10/Preset11/Preset12/Preset13/Preset14/Preset15/RestoreCameraPosition/DefaultCameraPosition>

Decide what the system is going to do on boot.

None: No action.

Preset 1..15: Activate the selected preset.

RestoreCameraPosition: Set the camera to the position it had before the last boot.

DefaultCameraPosition: Set the camera to the factory default position.

Example: Standby BootAction: DefaultCameraPosition

Standby Control: <On/Off>

Determine whether the system should go into standby mode or not.

On: Enter standby mode when the Standby Delay has timed out. Requires the Standby Delay to be set to an appropriate value.

Off: Not entering standby mode.

Example: Standby Control: On

Standby Delay: <1..480>

Define how long (in minutes) the system shall be in idle mode before it goes into standby mode. Requires the Standby Control to be enabled.

Range: 1-480 minutes

Example: Standby Delay: 10

Standby StandbyAction: <None/PrivacyPosition>

The setting determines what the system is going to do when going into standby mode.

None: No action.

PrivacyPosition: Turns the camera to a sideways position for privacy.

Example: Standby StandbyAction: PrivacyPosition

Standby WakeupAction: <None/Preset1/Preset2/Preset3/Preset4/Preset5/Preset6/Preset7/Preset8/Preset9/Preset10/Preset11/Preset12/Preset13/Preset14/Preset15/RestoreCameraPosition/DefaultCameraPosition>

Decide what the system is going to do when leaving standby mode.

None: No action.

Preset 1..15: Activate the selected preset.

RestoreCameraPosition: Set the camera to the position it had before entering standby.

DefaultCameraPosition: Set the camera to the factory default position.

Example: Standby WakeupAction: RestoreCameraPosition

The System Unit settings

SystemUnit CallLogging Mode: <On/Off>

Enables/disables logging of calls received or placed by the system. The call logs may then be viewed via the GUI or using the xHistory command.

On: Enable logging.

Off: Disable logging.

Example: SystemUnit CallLogging Mode: On

SystemUnit IrSensor Mode: <On/Off/Auto>

The System Unit IR Sensor setting determines whether the infrared receiver on the codec should be enabled or not. The IR sensor LED is located in the front of the codec and flickers when an ir signal is received from the remote control.

On: Set to On to enable the IR sensor on the codec.

Off: Set to Off to disable the IR sensor on the codec.

Auto: The system will automatically disable the IR sensor on the codec if the IR sensor at camera is enabled. Otherwise the IR sensor on the codec will be enabled.

Example: SystemUnit IrSensor Mode: On

SystemUnit MenuLanguage: <English/Norwegian/Swedish/German/French/Italian/Japanese/Russian/Spanish/Korean/Finnish/ChineseSimplified/ChineseTraditional/PortugueseBrazilian/Turkish/Polish>

Select a language for the menus on screen.

Example: SystemUnit MenuLanguage: English

SystemUnit Name: <S: 0, 50>

Enter a System Name to define a name of the system unit. If the H.323 Alias ID is configured on the system then this ID will be used instead of the system name. The system name will be displayed:

* When the codec is acting as an SNMP Agent

* Towards a DHCP server

Format: String with a maximum of 50 characters.

Example: SystemUnit Name: "Meeting Room Name"

The Time settings

Time DateFormat: <DD_MM_YY/MM_DD_YY/YY_MM_DD>

Specifies the date format.

DD_MM_YY: The date January 30th 2009 will be displayed: 30.01.09

MM_DD_YY: The date January 30th 2009 will be displayed: 01.30.09

YY_MM_DD: The date January 30th 2009 will be displayed: 09.01.30

Example: Time DateFormat: DD_MM_YY

Time TimeFormat: <24H/12H>

Specifies the time format.

24H: Set the time format to 24 hours.

12H: Set the time format to 12 hours (AM/PM).

Example: Time TimeFormat: 24H

Time Zone: <See the value space list>

Specifies the time zone where the system is located, using Windows time zone description format.

Value space list:

GMT-12:00 (International Date Line West)

GMT-11:00 (Midway Island, Samoa)

GMT-10:00 (Hawaii)

GMT-09:00 (Alaska)

GMT-08:00 (Pacific Time (US & Canada) Tijuana)

GMT-07:00 (Arizona)

GMT-07:00 (Mountain Time (US & Canada))

GMT-07:00 (Chihuahua, La Paz, Mazatlan)

GMT-06:00 (Central America)

GMT-06:00 (Saskatchewan)

GMT-06:00 (Guadalajara, Mexico City, Monterrey)

GMT-06:00 (Central Time (US & Canada))

GMT-05:00 (Indiana (East))

GMT-05:00 (Bogota, Lima, Quito)

GMT-05:00 (Eastern Time (US & Canada))

GMT-04:30 (Caracas)

GMT-04:00 (La Paz)

GMT-04:00 (Santiago)

GMT-04:00 (Atlantic Time (Canada))

GMT-03:30 (Newfoundland)

GMT-03:00 (Buenos Aires, Georgetown)

The Time settings, *continued...*

GMT-03:00 (Greenland)

GMT-03:00 (Brasilia)

GMT-02:00 (Mid-Atlantic)

GMT-01:00 (Cape Verde Is.)

GMT-01:00 (Azores)

GMT (Casablanca, Monrovia)

GMT (Greenwich Mean Time : Dublin, Edinburgh, Lisbon, London)

GMT+01:00 (West Central Africa)

GMT+01:00 (Amsterdam, Berlin, Bern, Rome, Stockholm, Vienna)

GMT+01:00 (Brussels, Copenhagen, Madrid, Paris)

GMT+01:00 (Sarajevo, Skopje, Warsaw, Zagreb)

GMT+01:00 (Belgrade, Bratislava, Budapest, Ljubljana, Prague)

GMT+02:00 (Harare, Pretoria)

GMT+02:00 (Jerusalem)

GMT+02:00 (Athens, Istanbul, Minsk)

GMT+02:00 (Helsinki, Kyiv, Riga, Sofia, Tallinn, Vilnius)

GMT+02:00 (Cairo)

GMT+02:00 (Bucharest)

GMT+03:00 (Nairobi)

GMT+03:00 (Kuwait, Riyadh)

GMT+03:00 (Moscow, St. Petersburg, Volgograd)

GMT+03:00 (Baghdad)

GMT+03:30 (Tehran)

GMT+04:00 (Abu Dhabi, Muscat)

GMT+04:00 (Baku, Tbilisi, Yerevan)

GMT+04:30 (Kabul)

GMT+05:00 (Islamabad, Karachi, Tashkent)

GMT+05:00 (Ekaterinburg)

GMT+05:30 (Chennai, Kolkata, Mumbai, New Delhi)

GMT+05:45 (Kathmandu)

GMT+06:00 (Sri Jayawardenepura)

GMT+06:00 (Astana, Dhaka)

GMT+06:00 (Almaty, Novosibirsk)

GMT+06:30 (Rangoon)

GMT+07:00 (Bangkok, Hanoi, Jakarta)

GMT+07:00 (Krasnoyarsk)

GMT+08:00 (Perth)

GMT+08:00 (Taipei)

The Time settings, *continued...*

GMT+08:00 (Kuala Lumpur, Singapore)
 GMT+08:00 (Beijing, Chongqing, Hong Kong, Urumqi)
 GMT+08:00 (Irkutsk, Ulaan Bataar)
 GMT+09:00 (Osaka, Sapporo, Tokyo)
 GMT+09:00 (Seoul)
 GMT+09:00 (Yakutsk)
 GMT+09:30 (Darwin)
 GMT+09:30 (Adelaide)
 GMT+10:00 (Guam, Port Moresby)
 GMT+10:00 (Brisbane)
 GMT+10:00 (Vladivostok)
 GMT+10:00 (Hobart)
 GMT+10:00 (Canberra, Melbourne, Sydney)
 GMT+11:00 (Magadan, Solomon Is., New Caledonia)
 GMT+12:00 (Fiji, Kamchatka, Marshall Is.)
 GMT+12:00 (Auckland, Wellington)
 GMT+13:00 (Nuku alofa)

Example: Time Zone: "GMT (Greenwich Mean Time : Dublin, Edinburgh, Lisbon, London)"

The Video settings

Video DefaultPresentationSource: <1..3>

Define which video input source shall be used as the default presentation source (e.g. when you press the Presentation key on the remote control). The input source is configured to a video input connector.

Range: 1-3 presentation sources

Example: Video DefaultPresentationSource: 3

Video Encoder Threshold60fps: <0..6000>

If the bandwidth used for transmitting video is above or equal to this threshold, the system will select the highest video resolution possible while maintaining 60 fps. If below this threshold, the system will select the highest video resolution possible while maintaining 30fps.

NOTE: This setting will only apply when the video input source to be transmitted is a 60fps source, and the selected video input is configured for motion.

Range: 0-6000 kbps

Example: Video Encoder Threshold60fps: 2048

Video Input DVI [2..3] Type: <AutoDetect/Digital/AnalogRGB/AnalogYPbPr>

The official DVI standard supports both digital and analog signals. In most cases the default AutoDetect setting can detect whether the signal is analog RGB or digital. However, in some rare cases when DVI-I cables are used (these cables can carry both the analog and digital signals) this detection might fail. This setting makes it possible to override the AutoDetect and select the correct DVI video input.

This setting should also be used if the video input is an analog component (YPbPr) type signal. This is used by some cameras (Sony EVI-HD1) and DVD/Blu-ray players. Since it is not possible to auto detect the difference between AnalogRGB and AnalogYPbPr, the Analog YPbPr setting has to be selected.

AutoDetect: Set to AutoDetect to automatically detect if the signal is analog RGB or digital.

Digital: Set to Digital to force the DVI video input to Digital when using DVI-I cables with both analog and digital pins and AutoDetect fails.

AnalogRGB: Set to AnalogRGB to force the DVI video input to AnalogRGB when using DVI-I cables with both analog and digital pins and AutoDetect fails.

AnalogYPbPr: Set to AnalogYPbPr to force the DVI video input to AnalogYPbPr, as the component (YPbPr) signal cannot be auto detected.

Example: Video Input DVI 2 Type: AutoDetect

Video Input Source [1..3] CameraControl CameraId: <1..5>

Select the ID of the camera in the Visca chain that is connected to this camera source. The CameraId setting represents the camera's position in the Visca chain. Addresses the specific video input source.

Cascaded cameras and Visca commands are described in the PrecisionHD 1080p User Guide. The user guide is found at www.tandberg.com/docs

Example: Video Input Source 1 CameraControl CameraId: 1

The Video settings, *continued...*

Video Input Source [1..3] CameraControl Mode: <On/Off>

Determines whether or not the camera control should be enabled for the specific video input source. Addresses the specific video input source.

On: Set to On to enable camera control for the camera connected to the selected video input connector.

Off: Set to Off to disable camera control for the camera connected to the selected video input connector.

Example: Video Input Source 1 CameraControl Mode: On

Video Input Source 1 Connector: <HDMI>

Select which video input connector to be active on connector group 1

HDMI: Select HDMI when you want to use the HDMI 1 connector as input

Example: Video Input Source 1 Connector: HDMI

Video Input Source 2 Connector: <HDMI/DVI>

Select which video input connector to be active on connector group 2

HDMI: Select HDMI when you want to use the HDMI 2 connector as input

DVI: Select DVI-I when you want to use the DVI-I 3 connector as input

Example: Video Input Source 2 Connector: HDMI

Video Input Source 3 Connector: <DVI/Composite/YC>

Select which video input connector to be active on connector group 3

DVI: Select DVI-I when you want to use the DVI-I 3 connector as input.

YC: Select YC when you want to use the S-Video (YC) input. Connect the S-Video input to the connector marked as Y/Comp and C. NOTE! This configuration is not supported in version 1.

Composite: Select Comp when you want to use the Composite input. Connect the Composite input to the connector marked

Example: Video Input Source 3 Connector: DVI

Video Input Source [1..3] Name: <S: 0, 50>

Customizable name of the connector group. Enter the name of the video input source 1-3.

Format: String with a maximum of 50 characters.

Example: Video Input Source 1 Name: ""

The Video settings, *continued...*

Video Input Source [1..3] Quality: <Motion/Sharpness>

When encoding and transmitting video there will be a tradeoff between high resolution and high framerate. For some video sources it is more important to transmit high framerate than high resolution and vice versa. The Quality setting specifies whether to give priority to high frame rate or to high resolution for a given source. Addresses the selected video input connector.

Motion: Gives the highest possible framerate. Used when there is a need for higher frame rates, typically when a large number of participants are present or when there is a lot of motion in the picture.

Sharpness: Gives the highest possible resolution. Used when you want the highest quality of detailed images and graphics.

Example: Video Input Source 1 Quality: Motion

Video Layout ScaleToFrame: <Manual/MaintainAspectRatio/StretchToFit>

Defines what to do if the aspect ratio of a video input source doesn't match the aspect ratio of the corresponding image frame in a composition. For example if you have a 4:3 input source (like XGA) to be displayed on a 16:9 output (like HD720).

Manual: If the difference in aspect ratio between the video input source and the target image frame is less than the ScaleToFrameThreshold configuration (in percent), the image is stretched to fit. Unless the system will maintain the original aspect ratio.

MaintainAspectRatio: Will maintain the aspect ratio of the input source, and fill in black in the rest of the frame (letter boxing or pillar boxing).

StretchToFit: Will stretch (horizontally or vertically) the input source to fit into the image frame.

Example: Video Layout ScaleToFrame: MaintainAspectRatio

Video Layout ScaleToFrameTreshold: <0..100>

Only applicable if the ScaleToFrame configuration is set to manual. If the difference in aspect ratio between the video input source and the target image frame is less than the ScaleToFrameThreshold configuration (in percent), the image is stretched to fit. Unless the system will maintain the original aspect ratio.

Example: Video Layout ScaleToFrameTreshold: 5

Video Layout Scaling: <On/Off>

Defines whether the system should automatically adjust aspect ratio for images or frames when it differs between the image and the frame it is to be placed in.

On: Let the system automatically adjust aspect ratio.

Off: Do not do any aspect ratio changes automatically.

Example: Video Layout Scaling: On

The Video settings, *continued...*

Video MainVideoSource: <1..3>

Define which video input source shall be used as the main video source. The input source is configured to a video input connector.

Range: 1-3 video sources

Example: Video MainVideoSource: 1

Video Monitors: <Single/Dual>

The codec can be used with more than one monitor and this setting lets you set the codec's monitor layout mode to Single or Dual.

Single: The same layout is shown on all monitors.

Dual: The layout is distributed on two monitors.

Example: Video Monitors: Single

Video OSD Mode: <On/Off>

The Video OSD (On Screen Display) Mode lets you define whether or not information and icons on screen should be displayed.

On: Set to On to display the on screen menus, icons and indicators (microphone on/off, encryption on/off).

Off: Set to Off to hide the on screen menus, icons and indicators (microphone on/off, encryption on/off).

Example: Video OSD Mode: On

Video OSD Output: <1..2>

The Video OSD (On Screen Display) Output lets you define which monitor should display the on screen menus, information and icons. By default the OSD output is displayed on the first monitor.

If you have a single monitor and you cannot see any OSD on the monitor: If the OSD output has been set to the second monitor and the second monitor is not connected, then you cannot see any menus, information or icons on the screen. To move the OSD output to the first monitor press the following shortcut sequence on the remote control. Press the Disconnect key followed by: * # * # 0 x # (where x is output 1 or 2).

Example: Video OSD Output: 1

Video Output HDMI [1..1] MonitorRole: <First/Second/PresentationOnly>

The monitor role describes what video stream will be shown on the monitor connected to the output connector. Applicable only if the "Video > Monitors" configuration is set to dual.

First: Show main video stream.

Second: Show presentation video stream if active, or other participants.

PresentationOnly: Show presentation video stream if active, and nothing else.

Example: Video Output HDMI 1 MonitorRole: First

The Video settings, *continued...*

Video Output HDMI [1..1] Resolution: <Auto/640_480_60/800_600_60/1024_768_60/1280_1024_60/1280_720_60/1920_1080_60/1280_768_60/1360_768_60/1366_768_60/1600_1200_60/1920_1200_60>

Select the preferred resolution for the monitor connected to HDMI video output. This will force the selected resolution on the monitor.

Auto: The system will automatically try to set the optimal resolution based on negotiation with the connected monitor.

Range: 640x480@60p, 800x600@60p, 1024x768@60p, 1280x1024@60p, 1280x720@60p, 1920x1080@60p, 1280x768@60p, 1360x768@60p, 1366x768@60p, 1600x1200@60p, 1920x1200@60p

Example: Video Output HDMI 1 Resolution: 1920_1080_60

Video Output DVI [2..2] MonitorRole: <First/Second/PresentationOnly/Third/Fourth>

The monitor role describes what video stream will be shown on the monitor connected to the output connector. Applicable only if the "Video > Monitors" configuration is set to dual.

First: Show main video stream.

Second: Show presentation video stream if active, or other participants.

PresentationOnly: Show presentation video stream if active, and nothing else.

Example: Video Output DVI 2 MonitorRole: Second

Video Output DVI [2..2] Resolution: <Auto/640_480_60/800_600_60/1024_768_60/1280_1024_60/1280_720_60/1920_1080_60/1280_768_60/1360_768_60/1366_768_60/1600_1200_60/1920_1200_60>

Select the preferred resolution for the monitor connected to DVI-I video output. This will force the selected resolution on the monitor.

Auto: The system will automatically try to set the optimal resolution based on negotiation with the connected monitor.

Range: 640x480@60p, 800x600@60p, 1024x768@60p, 1280x1024@60p, 1280x720@60p, 1920x1080@60p, 1280x768@60p, 1360x768@60p, 1366x768@60p, 1600x1200@60p, 1920x1200@60p

Example: Video Output DVI 2 Resolution: 1024_768_60

Video Output Composite [3] MonitorRole: <First/Second/PresentationOnly/Third/Fourth>

The monitor role describes what video stream will be shown on the monitor connected to the output connector. Applicable only if the monitor configuration is set to dual or quadruple.

First: Show main video stream.

Second: Show presentation video stream if active, or other participants.

PresentationOnly: Show presentation video stream if active, and nothing else.

Third: Use for remote participants (only for quadruple monitor setup).

Fourth: Use for remote participants (only for quadruple monitor setup).

Example: Video Output Composite 3 MonitorRole: First

The Video settings, *continued...*

Video Output Composite [3] Resolution: <PAL/NTSC>

Select the preferred resolution for the monitor connected to video output composite 3. This will force the selected resolution on the monitor.

Range: PAL, NTSC

Example: Video Output Composite 3 Resolution: NTSC

Video Selfview: <On/Off>

The Video Selfview setting determines whether or not the main video source (selfview) should be displayed on screen.

On: Set to On when you want selfview to be displayed on screen.

Off: Set to Off when you do not want selfview to be displayed on screen.

Example: Video Selfview: On

Video Wallpaper: <None/Growing/Summersky/Custom>

The Video Wallpaper setting determines whether or not a background picture should be displayed on screen when idle.

None: Set to None if you do not want a wallpaper to be displayed on screen.

Summersky, Growing: Select the wallpaper to be displayed on screen.

Custom: The custom wallpaper is uploaded from the web interface. Open a web browser and enter the IP address of the codec. Select "Wallpaper" from the menu on top of the screen. Browse for the file and press the "Upload" button. Toggle once between "None" and "Custom" wallpaper to make the change take effect. See the Appendices section for further details about the web interface.

Example: Video Wallpaper: Summersky

The Experimental menu, *cont...*

The Advanced configurations menu has an option called Experimental. The settings within this menu can be used 'as is' and will not be documented.

NOTE! The Experimental menu WILL change.

Experimental Audio Equalizer [1..8] Section [1..6] a1: <S: 0, 32>

Sets the a1 coefficient for the given equalizer ID and section number.

The system has 8 user defined equalizers, each made up of 6 second order IIR sections. See the Appendix, Equalizer section.

Example: Experimental Audio Equalizer 1 Section 1 a1: "0.0"

Experimental Audio Equalizer [1..8] Section [1..6] a2: <S: 0, 32>

Sets the a2 coefficient for the given equalizer ID and section number.

The system has 8 user defined equalizers, each made up of 6 second order IIR sections. See the Appendix, Equalizer section.

Example: Experimental Audio Equalizer 1 Section 1 a2: "0.0"

Experimental Audio Equalizer [1..8] Section [1..6] b0: <S: 0, 32>

Sets the b0 coefficient for the given equalizer ID and section number.

The system has 8 user defined equalizers, each made up of 6 second order IIR sections. See the Appendix, Equalizer section.

Example: Experimental Audio Equalizer 1 Section 1 b0: "0.0"

Experimental Audio Equalizer [1..8] Section [1..6] b1: <S: 0, 32>

Sets the b1 coefficient for the given equalizer ID and section number.

The system has 8 user defined equalizers, each made up of 6 second order IIR sections. See the Appendix, Equalizer section.

Example: Experimental Audio Equalizer 1 Section 1 b1: "0.0"

Experimental Audio Equalizer [1..8] Section [1..6] b2: <S: 0, 32>

Sets the b2 coefficient for the given equalizer ID and section number.

The system has 8 user defined equalizers, each made up of 6 second order IIR sections. See the Appendix, Equalizer section.

Example: Experimental Audio Equalizer 1 Section 1 b2: "0.0"

Experimental Audio Input Line [1..4] Equalizer ID: <1..8>

Select equalizer ID[1...8].

Example: Experimental Audio Input Line 1 Equalizer ID: 1

We recommend you visit the TANDBERG web site regularly for updated versions of the manual.

Go to: ► <http://www.tandberg.com/docs>

Experimental Audio Input Line [1..4] Equalizer Mode: <On/Off>

Determines whether or not the selected equalizer is enabled.

On: Use the selected equalizer

Off: No equalizer

Example: Experimental Audio Input Line 1 Equalizer Mode: Off

Experimental Audio Input Microphone [1..4] Channel: <Left/Right/Mono>

Defines whether the microphone input is a mono signal or part of a multichannel signal.

Left: The microphone input signal is the left channel of a stereo signal.

Right: The microphone input signal is the right channel of a stereo signal.

Mono: The microphone input signal is a mono signal.

Example: Experimental Audio Input Microphone 1 Channel: Mono

Experimental Audio Input Microphone [1..4] EchoControl HighPassFilter: <On/Off>

Set the microphone echo control high pass filter to on/off.

Example: Experimental Audio Input Microphone 1 EchoControl HighPassFilter: On

Experimental Audio Input Microphone [1..4] Equalizer ID: <1..8>

Select equalizer ID[1...8]

Example: Experimental Audio Input Microphone 1 Equalizer ID: 1

Experimental Audio Input Microphone [1..4] Equalizer Mode: <On/Off>

Determines whether or not the selected equalizer is enabled.

On: Use the selected equalizer

Off: No equalizer

Example: Experimental Audio Input Microphone 1 Equalizer Mode: Off

Experimental Audio Output Line [1..6] Equalizer ID: <1..8>

Select equalizer ID[1...8]

Example: Experimental Audio Output Line 1 Equalizer ID: 1

Contents	Introduction	Getting started	About the menus	The settings menu	Settings Library	Cameras	Appendices	Contact us
----------	--------------	-----------------	-----------------	-------------------	------------------	---------	------------	------------

The Experimental settings, *continued...*

Experimental Audio Output Line [1..6] Equalizer Mode: <On/Off>

Determines whether or not the selected equalizer is enabled.

On: Use the selected equalizer

Off: No equalizer

Example: Experimental Audio Output Line 1 Equalizer Mode: Off

Experimental CapsetFilter: <S: 0, 32>

To be described.

Example: Experimental CapsetFilter: ""

Experimental CustomSoftbuttons State [1..2] Softbutton [1..5] Type: <NotSet/MainSource/PresentationSource/CameraPreset/Actions/SpeedDial>

To be described.

Example: Experimental CustomSoftbuttons State 1 Softbutton 1 Type: NotSet

Experimental CustomSoftbuttons State [1..2] Softbutton [1..5] Value: <S: 0, 255>

To be described.

Example: Experimental CustomSoftbuttons State 1 Softbutton 1 Value: ""

Experimental Video OptimalDefinition Profile: <Normal/Medium/High>

Video quality is determined by a combination of resolution and frame rate and varies based on bandwidth.

Normal, Medium, High: See the Video optimal definition tables below.

Table 1: For systems supporting 1080p

	w288p30	w448p30	w576p30	720p30	1080p30
Normal	256kbit/s	512 kbit/s	768 kbit/s	1152 kbit/s	2560 kbit/s
Medium	128kbit/s	384 kbit/s	512 kbit/s	768 kbit/s	1920 kbit/s
High	128kbit/s	256 kbit/s	512 kbit/s	768 kbit/s	1472 kbit/s

Table 2: For systems supporting 720p60

	w144p60	w288p60	w448p60	w576p60	720p60
Normal	128kbit/s	512 kbit/s	1152 kbit/s	1472 kbit/s	2240 kbit/s
Medium	128kbit/s	384 kbit/s	768 kbit/s	1152 kbit/s	1472 kbit/s
High	128kbit/s	256 kbit/s	512 kbit/s	768 kbit/s	1152 kbit/s

Example: Experimental Video OptimalDefinition Profile: Normal

Chapter 8

Cameras

Your TANDBERG PrecisionHD 1080p Camera has been designed to give you many years of safe, reliable operation.

Additional information about the camera is found in the TANDBERG PrecisionHD 1080p User Guide.



In this chapter...

- ▶ The PrecisionHD 1080p camera
 - ▶ Connecting the camera
 - ▶ Best view—Face recognition
 - ▶ Video output formats
 - ▶ Cameras in daisy chain

The PrecisionHD 1080p camera

Video out (HDMI, HD-SDI). For video signals, connect from the video out on the camera to the video in on the codec.

Power and camera control. For power in and camera control, connect from the camera control & power on the camera to the Camera port on the codec. When the camera is used with TANDBERG codecs power will be supplied through Camera Control cable. When used with non-TANDBERG Codecs, you may have to connect power separately.

HDMI and HD-SDI

- HDMI is the main source for video out when connected to Codec C60. Maximum resolution is 1080p60.
- HD-SDI is the secondary source for video. Maximum resolution is 1080p30.
- The HDMI and HD-SDI can be used simultaneously. The maximum resolution is then 1080p30 if you want both to run with the same resolution.

Kensington lock

The Kensington lock may be used to prevent the camera to be moved from its place or to prevent theft.

Cascaded cameras

The sockets named Extra Camera Out and Power In are used when connecting cameras in daisy chain.

- The first camera in the chain is powered up by the camera control cable. The next cameras must use the 12V DC Power in.
- The daisy chained cameras are connected by using an extra camera cable between the Extra Camera sockets.

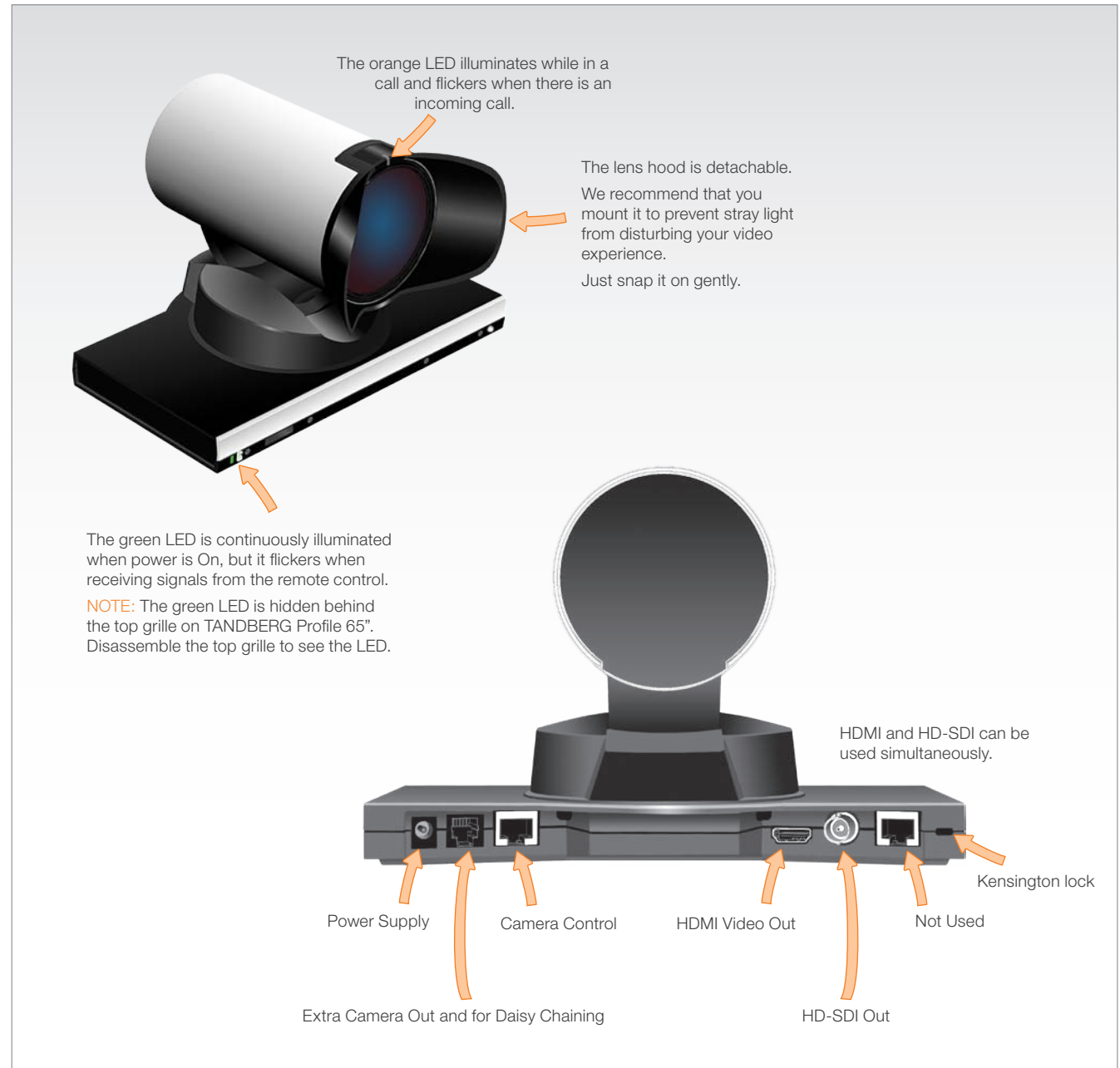

See the **TANDBERG PrecisionHD 1080p User Guide** for comprehensive information about the camera.
 Go to: <http://www.tandberg.com/docs>

The PrecisionHD 1080p camera, cont...

Connecting the camera

The HDMI and HD-SDI can be used simultaneously.

HDMI cable

The HDMI cable delivered with the camera is 5 meters.

Maximum length is 15 meter with a category 2 certified good quality HDMI cable.

HD-SDI cable

The HD-SDI cable must be purchased separately. The maximum recommendable length of HD SDI cable is 100m.

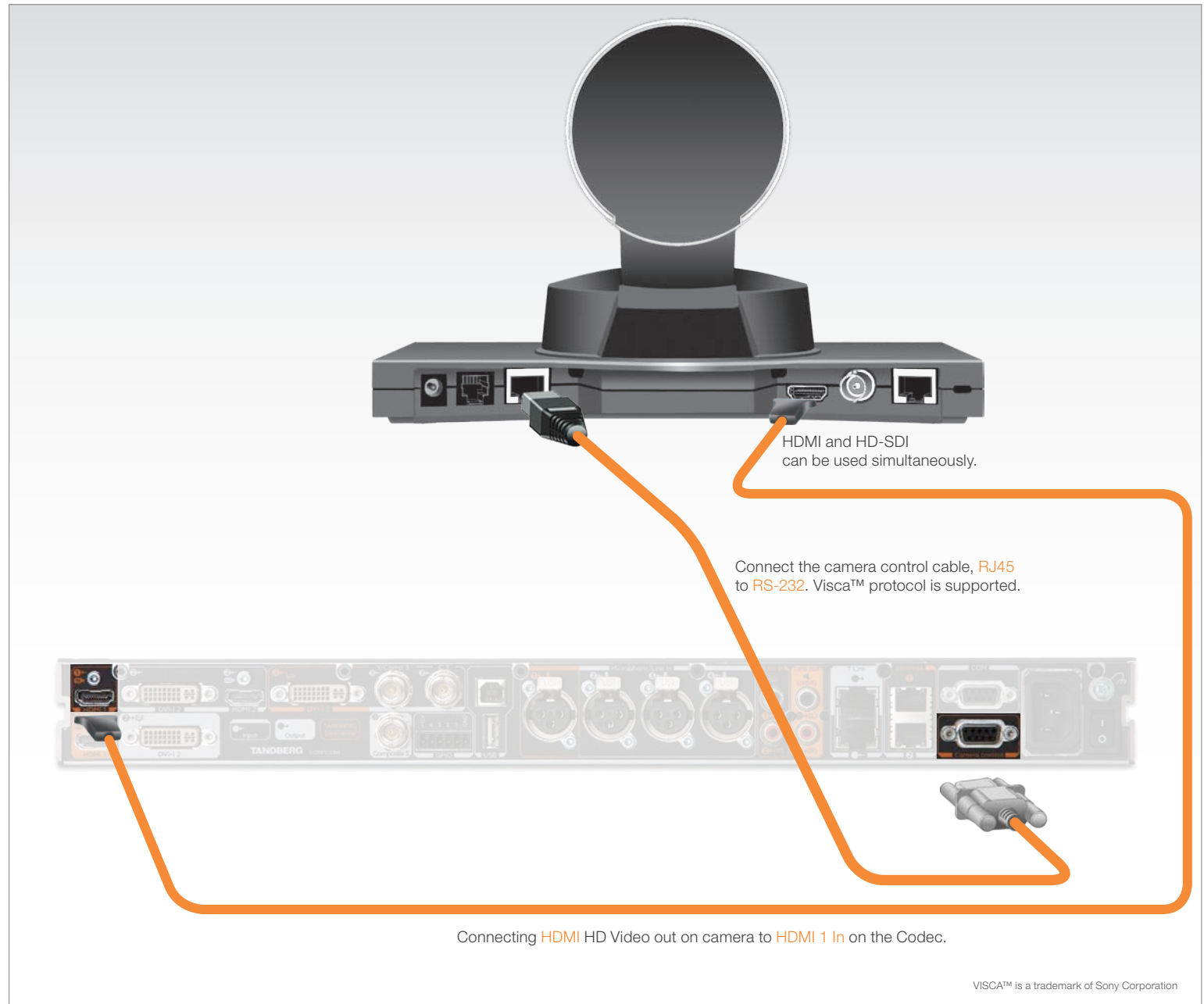

The PrecisionHD 1080p camera, cont...

Best view—Face recognition

This camera is capable of face recognition when used with TANDBERG C60/C90 Codecs. Consequently, the functionality is subject to change without prior notice in order to take advantage of further developments.

NOTE: Observe that the **Best view** feature is still a preview feature.

The face recognition system aims to search for faces in order to optimize the picture frame, hence the name **Best view**. Once a face or group of faces has been detected camera zoom and camera angle will be changed accordingly to obtain an optimal presentation on the screen.

Read this before using Best view:

- The **Best view** optimization process may take up to 5 seconds.
- The detection of faces works better when people look towards the camera.
- The area from the eyebrows down to just below the lips should be uncovered.
- Beard is normally not a problem.

Using Best view

Note that **Best view** works with TANDBERG C60/C90 Codecs only!

1. Press the **Layout** key on the remote control to display the Layout menu. Select **Selfview** to be shown as required.
2. Press the **Home** key on the remote control to display the Home menu and select **Camera control**
3. Press the second soft button on the remote control to display the **Preset** menu. Select **Best view** from the menu press the **OK** key on the remote control to start the Best view optimization process.
4. Look towards the camera for about five seconds. The system will look for human faces and adjust the zoom and camera angle to obtain a best fit.

Select **Selfview** to be shown.

The PrecisionHD 1080p camera, cont...

Video output formats

This section describes the video output formats for the TANDBERG PrecisionHD 1080p camera.

DIP switch settings for video output formats

The DIP switch sets the video output format for the camera. The DIP switch is on the underside of the camera. The default setting is Auto. See the table to the right.

- Maximum resolution for HDMI is 1080p60
- Maximum resolution for HD-SDI is 1080p30.

Line voltage frequency

The camera will automatically detect the line voltage frequency when it is 50 or 60 Hz. If there is a different line voltage, you can set the video output format to a specific value (use the DIP switches) to override the auto frequency detection.

Set the PrecisionHD 1080p DIP switch (country specific setting):

- 50Hz: 00011, gives 1080p50 (720p50 for HD-SDI)
- 60Hz: 00100, gives 1080p60 (720p60 for HD-SDI)

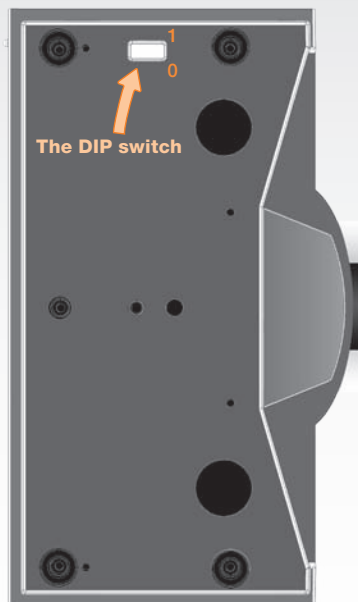

Underside side of the TANDBERG PrecisionHD 1080p camera

DIP Switch table for video formats					HDMI	HD-SDI
1	2	3	4	5		
0	0	0	0	0	Auto	
0	0	0	0	1	1920x1080p25	1920x1080p25
0	0	0	1	0	1920x1080p30	1920x1080p30
0	0	0	1	1	1920x1080p50	1280x720p50
0	0	1	0	0	1920x1080p60	1280x720p60
0	0	1	0	1	1280x720p25	1280x720p25
0	0	1	1	0	1280x720p30	1280x720p30
0	0	1	1	1	1280x720p50	1280x720p50
0	1	0	0	0	1280x720p60	1280x720p60
0	1	0	0	1	Software control	

The table shows the different settings available for the HDMI and the HD-SDI outputs.

Auto: Camera negotiates format over HDMI. HD-SDI tracks HDMI and defaults to 1080p30 in absence of HDMI sync.

Software: For more on the **Software control** setting, read about video mode selections in the TANDBERG PrecisionHD 1080p User Guide.

Chapter 7

Appendices



In this chapter...

- ▶ General room guidelines
- ▶ Meeting room setup
- ▶ Remote control TRC5
- ▶ Password protection
- ▶ Startup scripts
- ▶ The web interface
 - ▶ System info page
 - ▶ Software upgrade
 - ▶ Advanced configuration
 - ▶ Custom wallpaper
 - ▶ Making a call
 - ▶ Upload certificate
 - ▶ XML files
 - ▶ Logs
 - ▶ Add release key
- ▶ The DNAM
- ▶ Supported RFCs in SIP
- ▶ China RoHS
- ▶ CE Declaration
- ▶ Dimensions
- ▶ Technical specifications

General room guidelines

The physical conditions

When building a video meeting room, or using an existing room for video meetings there are a few guidelines to consider.

Lighting

- The illumination should be distributed evenly in the room to obtain low contrast
- The ideal light intensity is a little higher than in an ordinary meeting room. Typically, the luminous intensity should be 800–1400Lux, measured at the table with an incident light meter

Seating area and table

- The seating area and table should be non-shiny and non-patterned
- The seating area should allow all participants to see the monitor

Walls

- The color of the wall should be in good contrast to skin tonality. Light blue is a complementary color to skin tonality, it gives a good contrast and is commonly used
- Acoustically reflective surfaces (such as glass or concrete) should be covered with curtains or sound treatment

Audio

- The Noise Floor (the sum of all the noise sources) should be less than max 35dBA
- The reverberation time should be 0,3 to 0,5 seconds

Ventilation

- When having a TANDBERG Profile system installed the requirements for ventilation is higher than in an ordinary meeting room. See the [Technical specifications](#) section in the [Appendices](#) to find the output values for your TANDBERG Profile.
- Keep in mind the Noise Floor (see Audio)
- Velocity creates noise, therefore keep velocity of air low

The room equipment

When placing and using the room equipment there are a few recommendations and guidelines to consider.

The microphone

- The microphones should be evenly distributed on the table. Avoid positions where they can be hidden behind obstacles like laptop, projector or other equipment placed on the table
- Do not place a microphone close to noisy equipment like computer and projector fans, power outlets or similar arrangements on the table. The microphone will pick up noise from these arrangements quite strongly.

The camera

- The camera should be able to “see” all participants in the room. Use the pan, tilt and zoom features to adjust the picture

The PC

- PC's placed on the table should not cover the microphones as this will reduce the audio quality at the far end

Position of the system

- Position the video system in such a way that all participants attending the meeting are visible to the far end
- If appropriate, the far end should be able to see people entering or leaving the room

The document camera

- The document camera should be close to the chair person or a designated controller of the document camera for ease of use. Make sure this person is visible on screen while carry out the task

Other peripherals

- Arrange all the peripherals so that the chair person can reach each of them to point, change the display, DVD, and still be fully visible on screen while carry out the task

Environmental considerations

This section explains how to carry out basic adjustments and simple tests to ensure that you send and receive the best possible image and audio quality when using your system.

Iris control and lighting

By default the system camera will use an automatic iris to compensate for changes in lighting. In addition to this feature, you may further assist the system to maintain the best possible image quality by paying special attention to environmental lighting and background colors as described below.

Remember the system will send live images of both yourself and your immediate surroundings.

- Avoid direct sunlight on the subject matter i.e. yourself, the background or onto the camera lens as this will create harsh contrasts
- Avoid placing the seatings in front of a window with natural daylight, as this will make the faces of people very dark
- If light levels are too low you may need to consider using artificial lighting. As described above, direct illumination of the subject matter and camera lens should be avoided
- When using artificial lighting, daylight type lamps will produce the most effective results. Avoid colored lighting
- Indirect light from shaded sources or reflected light from pale walls often produces excellent results
- Avoid harsh side lighting or strong light from above. Strong sunlight from a window or skylight may put part or all of the subject matter in shadow or cause silhouetting

Loudspeaker volume

The audio system will use the Digital Natural Audio Module (DNAM) which is integrated in the system. The volume of the audio is controlled by the Volume key on the remote control.

The audio quality

To keep the high quality audio, make sure there is free sight to the speaker module

- There should be free sight between the ears of the participants and the system speaker module
- Participant sitting too far away from the video system may not have the same audio quality as the others.

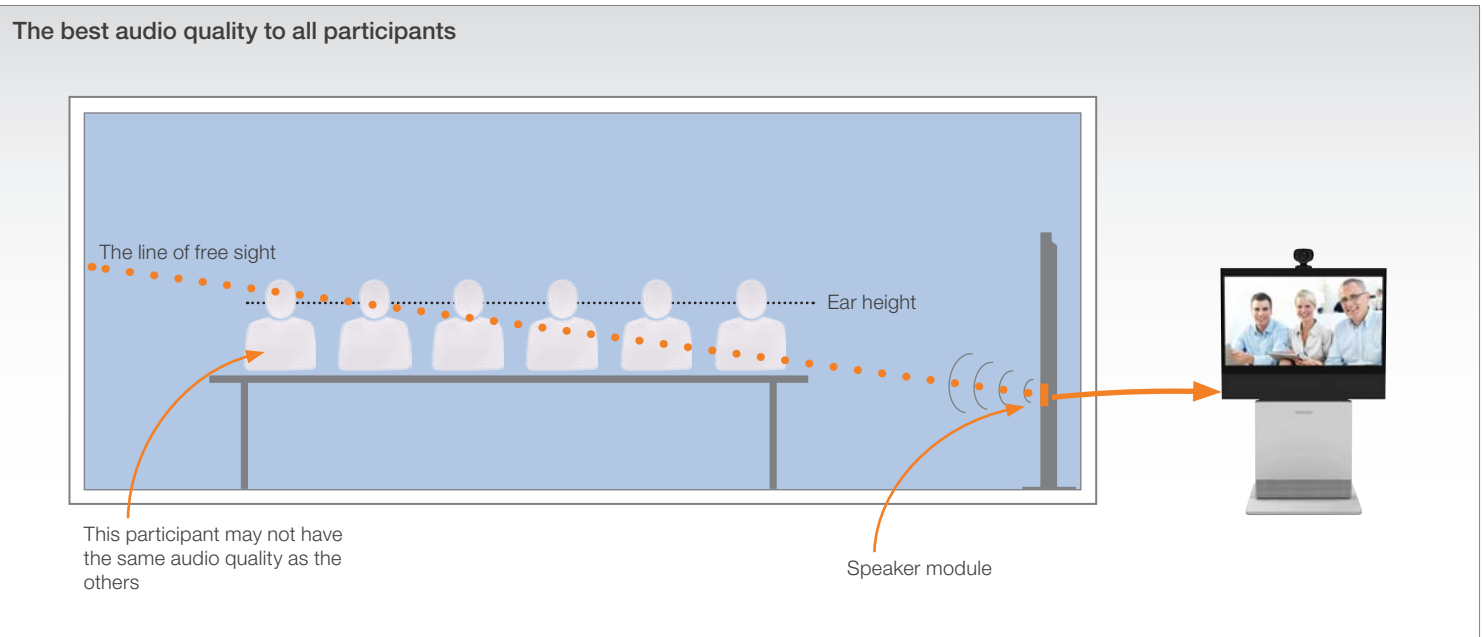

Natural communication

Making eye contact with the far end participants will improve the natural communication between the people

- Adjust the camera view (using zoom in/out) to allow the participants to be shown in full size on screen, and to keep eye contact with each other at the same eye level
- If the participants are sitting too close to the monitor the camera will “look down” at the participants. This may not give a good presentation of the participants at the far end.

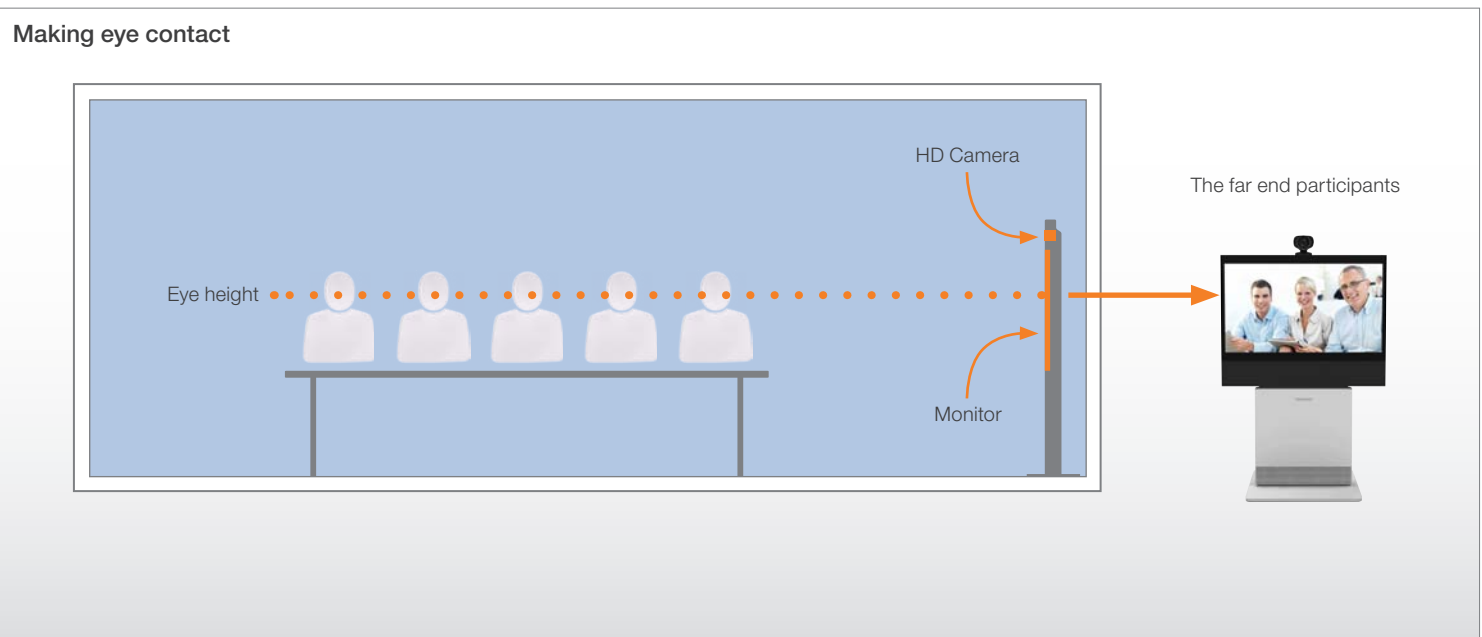

Guidelines for meeting room setup

For team collaboration rooms, team meeting rooms and showroom floor.

General recommendations for the room layout

To fully utilize the experience there are some guidelines you should consider.

The distance between the table and the video system

- The monitors are full HD LCD display and requires some distance to the table to allow all participants to see a clear picture on screen
 - The 42"/52" monitors requires minimum 1,5 m / 59 inch
 - The 65" monitor requires 2–2,5 m / 78–98 inch
- The camera should capture all participants in the room.
- The camera angle at maximum zoom out is 72°.
- Adjust the camera view (using zoom in/out) to allow the participants to be shown in full size on screen, and to keep eye contact with each other at the same eye level
- If the participants are sitting too close to the monitor the camera will "look down" at the participants. This may not give a good presentation of the participants at the far end.

The speaker module

- The speaker module requires a minimum of 1,5 m / 59 inch free space in front
- There should be free sight between the system speaker module and the ear of the participants.

The microphones

- The microphones should be evenly distributed on the table
- Avoid positions where they can be hidden behind obstacles like laptop or other equipment placed on the table
- Do not place a microphone close to noisy equipment like computer and projector fans, power outlets or similar arrangements on the table. The microphone will pick up noise from these arrangements quite strongly.

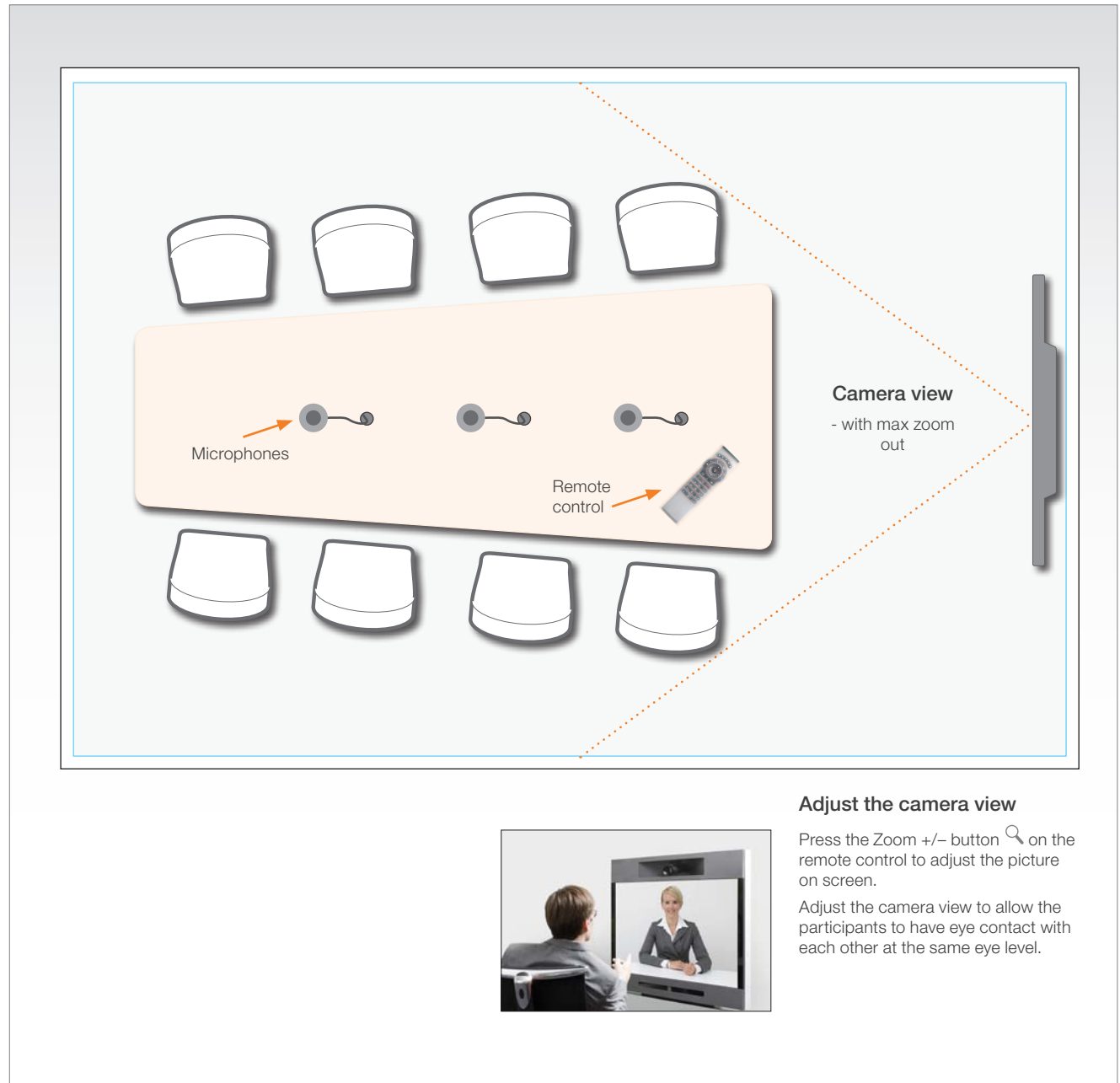

Adjust the camera view

Press the Zoom +/- button  on the remote control to adjust the picture on screen.

Adjust the camera view to allow the participants to have eye contact with each other at the same eye level.



Sharing a PC presentation

Dual video stream

With dual video stream you can view two different live video streams simultaneously, the main video and one additional source. This could for example be both a PC presentation and the person who gives the presentation.

If one of the video systems does not support Dual Video Stream, no second video stream will be established and the PC presentation will be shown as the main video.

Sharing the presentation

1. Make sure the PC do not cover any of the microphones as this will reduce the audio quality at the far end
2. Locate the DVI cable and connect the PC to the video system
3. When pressing the PC button (🖥️) on the remote control the default presentation source is activated.

The DVI/VGA input is compliant with VESA Extended Display Identification Data (EDID) and will be able to notify the PC of the supported output formats.

Troubleshooting if the presentation does not show

- On most PC's you must press a special key combination to switch the PC image from the PC screen to the video screen
- Make sure the connector used for PC presentation is configured as the default presentation source.
Go to: **Home > Settings > Advanced > Advanced configuration > Video > DefaultPresentationSource** (the default value is 3, and corresponds to **Home > Settings > Advanced > Advanced configuration > Video > Input > Source 3**)
- Make sure your PC is set to activate your VGA output

Other presentation sources

You can also connect other presentation sources like:

- DVD
- Document camera

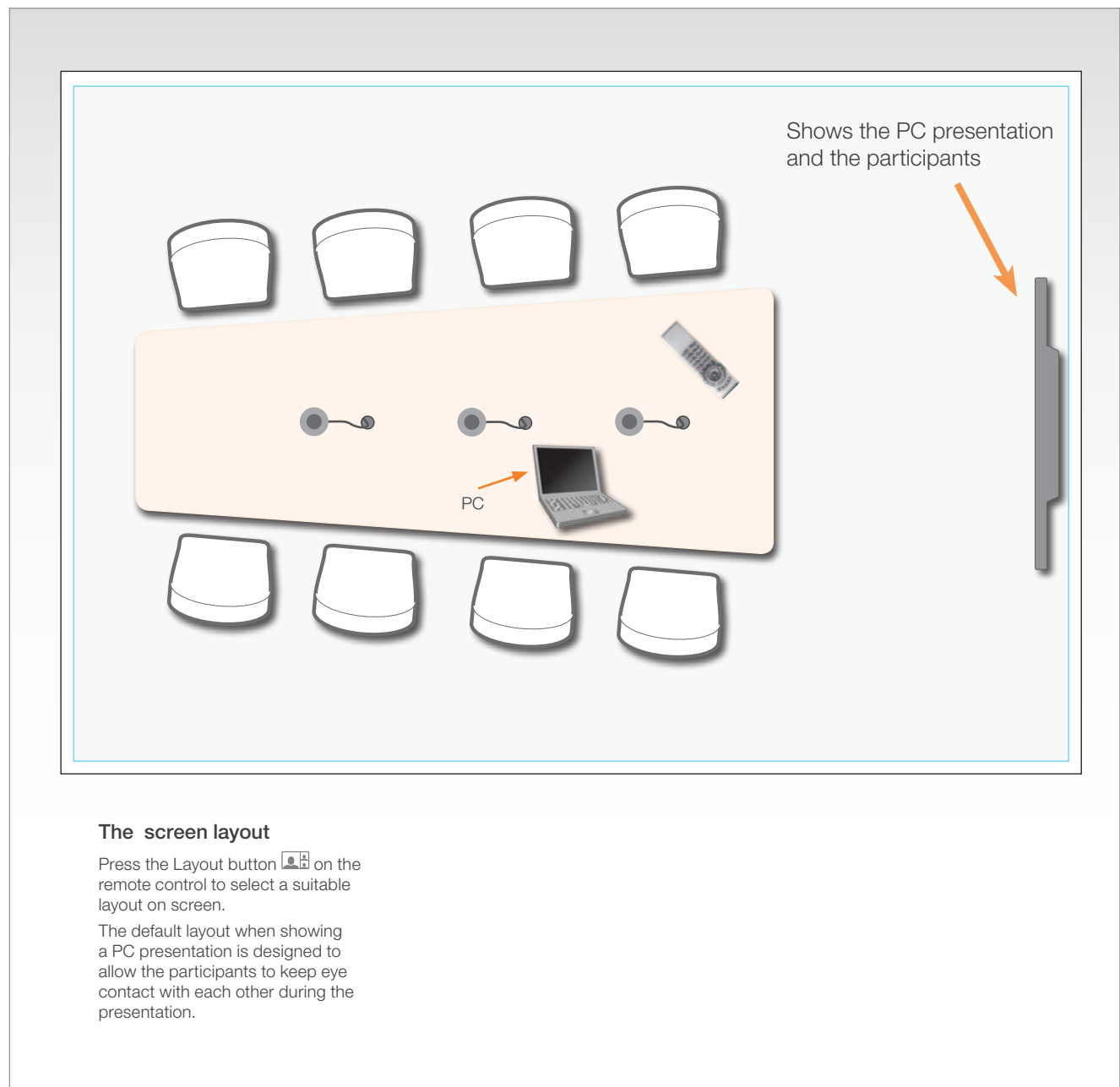

The screen layout

Press the Layout button (🖥️) on the remote control to select a suitable layout on screen.

The default layout when showing a PC presentation is designed to allow the participants to keep eye contact with each other during the presentation.

TANDBERG Remote Control TRC5

Function keys: Represents shortcuts and advanced functions. Each key reflects a soft key on screen.

Microphone: Press the  key to toggle the microphones on/off.

Volume: Press the + or - on the  key to adjust the codec volume.

Mute: Press the - on the  key to mute the volume during an incoming call.

OK/Select: Press the  key to confirm your choice or selection.

Phone book: Press the  key to display the local Phone book.

Home: Press the  key to key to show the menu on screen.

Call: Using the  key:
 INITIATE A CALL: Select a name from the Phone book or enter the name, number or URI and press the Call key to initiate the call.
 SHORTCUT TO RECENT CALLS: Use the Call key as a shortcut to Recent Calls when the Call menu is not visible.

Clear: Press the  key to remove characters in a text field.

Waking up the system
 Grab the remote control and make sure your hand touches the rubber line sensors going along both sides of the remote control.
 or: Touch any key on the remote control.



Presentation: Press the  key to show/hide a presentation.

Zoom: Press the + or - on the  key to zoom the camera in and out.

Arrows:

- **Up/Down:** Use the ▲ and ▼ arrow keys to navigate in the menu.
- **Arrow Right:** Press the ► arrow key to expand the selected menu item or to move to the right in a text field.
- **Arrow Left:** Press the ◀ arrow key to go one step back in the menu or to move to the left in a text field.

Layout: Press the  key to display the Layout menu, then select a view in the menu.

End call/Standby: Press the  key to end a call, or when idle, press and hold the key to go into standby mode.

Alphanumeric keypad: Use the keypad in the same way as you would use a cellular phone.

- 0-9, a-z, period (.), @, space, *: Press a key repeatedly to toggle between the options displayed on each key.
- abc/123 #: Press the # key to toggle between touch tones mode (long press), lower case characters and numbers.

IR transmitter range (DIP switch setting)
 The IR transmitter has a short and long range. Open the battery cover and remove the batteries to set the DIP switch.

- Short range (1 m): Move the DIP switch down.
- Longer range: Move the DIP switch up.

Password protection

The system can be password protected in three ways:

1. The **Advanced menus** can be password protected with a menu password.
2. The **codec** can be password protected with an administrator password.
3. The **web interface** is password protected with the same administrator password as for the codec. **NOTE!** Requires a reboot of the codec.

NOTE! When a new password has been defined make sure you save a copy of the password in a safe place.

Contact your TANDBERG representative if you have forgotten the password.

Setting the codec administrator password

Do the following to define the administrator password on the codec:

1. Connect to the codec through the network or the serial data port, using a command line interface (ssh, telnet or scp)
2. Login to the codec with user name (admin) and no password.
3. Run the following API command and enter a password:

```
xCommand SystemUnit AdminPassword Set
Password: "*****"
```
4. The password format is a string with 0–255 characters.
5. **Reboot** the codec.

Password protection of the web interface

The web interface is password protected with the same user name and password as defined for the codec.

NOTE! To activate the administrator password on the web interface, after having defined or changed the administrator password, a reboot of the codec is required. Without a reboot the administrator password will only apply when you login to the codec.

Login to the codec or the web interface

- You can login to the codec with the user name and password, either from a web interface or from a command line interface. You will need to enter both the user name and password.
- The user name is **admin**, and cannot be changed.

How to deactivate the administrator password

1. Connect to the codec through the network, using a command line interface (ssh, telnet or scp).
2. Login to the codec with the required user name (admin) and password.
3. Run the following API command with a blank password:

```
xCommand SystemUnit AdminPassword Set
Password: ""
```
4. **Reboot** the codec.

Setting the menu password

Do the following to define a password for the Advanced menus:

1. Open the menu on screen and go to: **Home > Settings > Advanced > Change password.**
2. The password is a string with 0–255 characters.
3. Enter the password and press **Save**.

Login to the Advanced menu

When a password is set, the password is required to get access to the Advanced menu on screen.

How to change the menu password

1. To change the password, go to: **Home > Settings > Advanced > Change password** in the menu.
2. Enter the new password in the **Set password** menu.
3. Press **Save** to save the new password.

How to deactivate the menu password

1. To change the password, go to: **Home > Settings > Advanced > Change password** in the menu.
2. Leave the text field empty in the **Set password** menu.
3. Press **Save** to save the blank password. This will deactivate the menu password.

Startup script

You can add a startup script on the codec to execute certain commands from the API during boot up.

Adding a startup script

The startup script can be used to execute certain commands from the API during boot up. To enable this feature one must log in to the codec as root and follow the below points.

Login to the codec

1. Connect to the codec through the network, using a command line interface (ssh, telnet or scp) and login as `root`
2. Make a user directory using the following command: `mkdir /user/scripts.d`
3. Put an executable file (permission must be changed to executable) in this directory.

Example of such a file:

```
#!/usr/bin/env tsh
xCommand Audio LocalInput Update InputId: 1 MixerMode:Fixed
```

About the startup script file

- The file must start with the following sequence:
`#!/usr/bin/env tsh`
- The file can contain any `xCommand` or `xConfiguration` command
- The system will execute the commands/configurations in sequence.
- The file can have any name as long as it is placed in this directory.
- For multiple commands you must use Unix end of line (LF). Windows end of line will not work.

The web interface

The web interface allows for remote administration of the system.

Open a web browser and enter the IP address of the codec. From this page you have the following menu options:

- **System info**
- Upgrade software
- Advanced configuration
- Wallpaper
- Call
- Upload certificates
- XML files
- Logs
- Add release key

Password protection of the web interface

The web interface is password protected with the same user name and password as defined for the codec. See the [Password protection](#) section in the Appendices for a detailed description.

NOTE! To activate the administrator password on the web interface, after having defined or changed the administrator password, a reboot of the codec is required. Without a reboot the administrator password will only apply when you login to the codec.

The system info page

The screenshot displays the web interface for a TANDBERG C60 codec. The main heading is "TANDBERG C60". On the left, there is a navigation menu with the following items: "System info" (highlighted), "Upgrade software", "Advanced configuration", "Wallpaper", "Call", "Upload certificates", "XML files", "Logs", and "Add release key". The main content area shows the "System Info" page, which includes the title "TANDBERG Codec C60" and the following details: "System name: TANDBERG Codec C60", "Software version: TC2.0.0.191232", "IP address: 10.47.6.113", and "Product: TANDBERG Codec C60". At the bottom right of the main content area, it says "SW: TC2.0.0.191232". The status bar at the very bottom of the browser window shows "Done".

The web interface, cont...

The web interface allows for remote administration of the system.

Open a web browser and enter the IP address of the codec. From this page you have the following menu options:

- System info
- **Upgrade software**
- Advanced configuration
- Wallpaper
- Call
- Upload certificates
- XML files
- Logs
- Add release key

The Upgrade software page

The screenshot shows the TANDBERG C60 web interface. On the left is a navigation menu with the following items: System info, Upgrade software (highlighted in orange), Advanced configuration, Wallpaper, Call, Upload certificates, XML files, Logs, and Add release key. The main content area is titled 'Upgrade software' and contains a file input field with a 'Browse...' button and an 'Upgrade' button below it.

How to upgrade the software on the codec:

1. Contact your TANDBERG representative to obtain the software upgrade file.
2. Click **Browse...** and locate the upgrade file (.PKG)
3. Click the **Upgrade** button to start the installation.
4. Leave the system to allow the installation process to complete. You can follow the progress on this page. When the upgrade is successfully completed a message will appear. The upgrade process takes a few minutes.

The web interface, cont...

The web interface allows for remote administration of the system.

Open a web browser and enter the IP address of the codec. From this page you have the following menu options:

- System info
- Upgrade software
- **Advanced configuration**
- Wallpaper
- Call
- Upload certificates
- XML files
- Logs
- Add release key

The Advanced configuration page

The Advanced configuration defines the system settings and are structured in a hierarchy, making up a database of system settings.

Expanded view

Edit a value: To change a value, click on the value to see the expanded view as shown above.

Save: Click the **OK** button to save the new value.

Cancel: When you want to leave without saving, click **Cancel**.

The web interface, cont...

The web interface allows for remote administration of the system.

Open a web browser and enter the IP address of the codec. From this page you have the following menu options:

- System info
- Upgrade software
- **Advanced configuration**
- Wallpaper
- Call
- Upload certificates
- XML files
- Logs
- Add release key

The Advanced configuration, search functionality

TANDBERG C60

System info
Upgrade software
Advanced configuration
Wallpaper
Call
Upload certificates
XML files
Logs
Add release key

Advanced Configuration

H323

- 📁 H323
 - 📁 Profile 1
 - PortAllocation: **Dynamic**
 - 📁 H323Alias
 - ID: **firstname.lastname@tandberg.com**
 - E164: **5522111**
 - 📁 CallSetup
 - Mode: **Gatekeeper**
 - 📁 Gatekeeper
 - Address: **10.47.1.58**
 - Discovery: **Manual**
 - 📁 Authentication
 - LoginName: **Click to edit...**
 - Password: **Click to edit...**
 - Mode: **Off**
 - 📁 NetworkServices
 - 📁 H323
 - Mode: **On**

Done

The search functionality

When searching for words like **H323** or **SIP**, all settings beginning with these words, included all settings below in the hierarchy, will show in the list.

Search: Enter as many characters as needed to get the desired result and click the **Search** button to initiate the search.

Clear: Click the **Clear** button to return to the main view.

The web interface, cont...

The web interface allows for remote administration of the system.

Open a web browser and enter the IP address of the codec. From this page you have the following menu options:

- System info
- Upgrade software
- Advanced configuration
- **Wallpaper**
- Call
- Upload certificates
- XML files
- Logs
- Add release key

The Wallpaper page

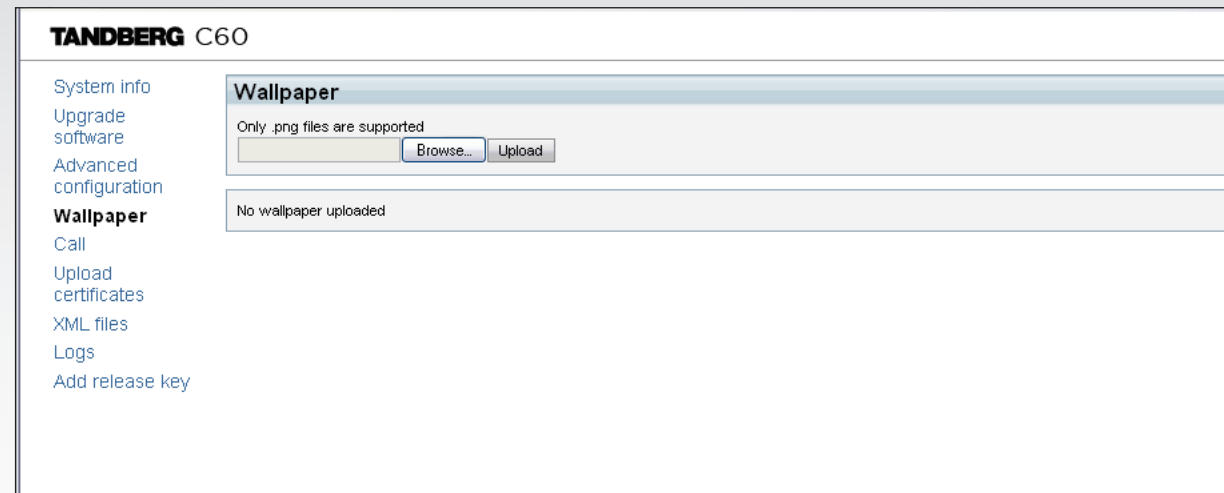

How to upload a custom wallpaper to the codec and configure the codec to make use of it:

1. Click the **Browse...** button to locate the wallpaper file (.PNG)
2. Click the **Upload** button to upload the file to the codec and refresh the web page to see the wallpaper you just uploaded.
3. Go to: **Advanced configuration** page and search for **Wallpaper**. From the drop down list, select **Custom**. The new wallpaper should now show on the monitor which is connected to the codec.

If the new wallpaper does not show on the monitor connected to the codec, you may have to toggle once between Wallpaper: **None** and **Custom** to make the change take effect.

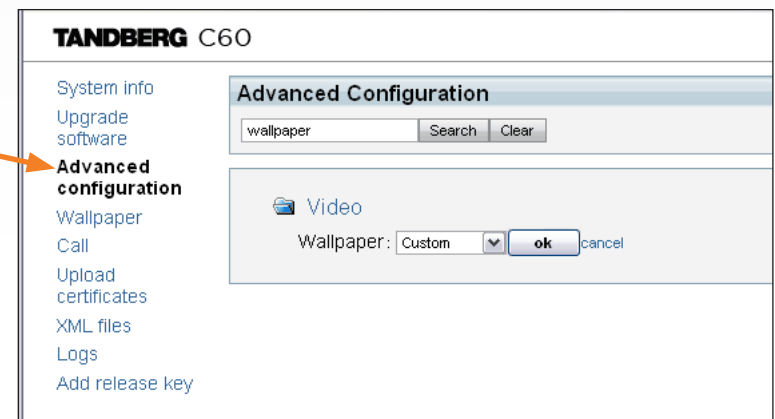

The web interface, *cont...*

The web interface allows for remote administration of the system.

Open a web browser and enter the IP address of the codec. From this page you have the following menu options:

- System info
- Upgrade software
- Advanced configuration
- Wallpaper
- **Call**
- Upload certificates
- XML files
- Logs
- Add release key

The Call page

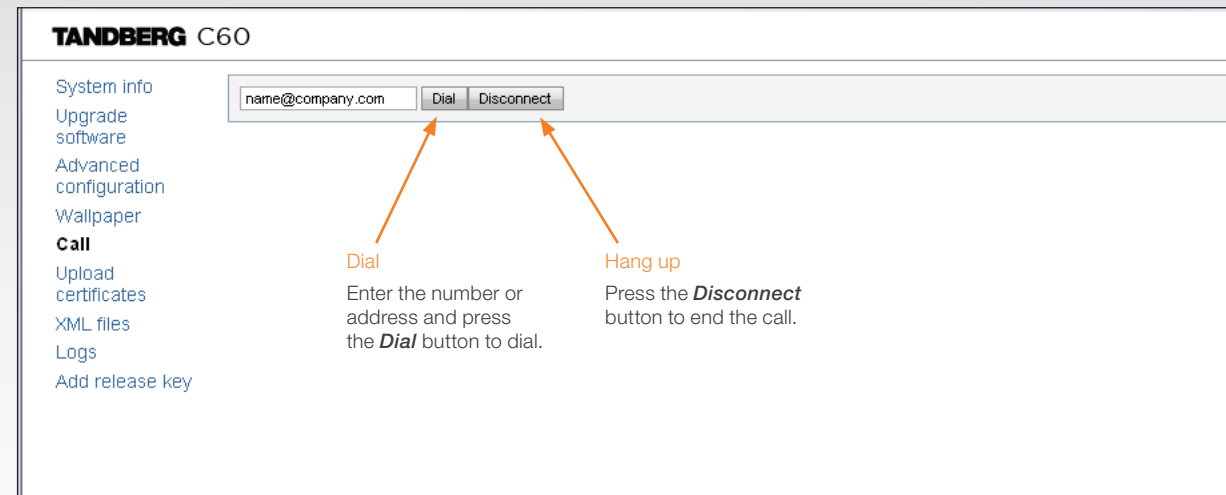

TANDBERG C60

System info
Upgrade software
Advanced configuration
Wallpaper
Call
Upload certificates
XML files
Logs
Add release key

name@company.com Dial Disconnect

Dial
Enter the number or address and press the **Dial** button to dial.

Hang up
Press the **Disconnect** button to end the call.

NOTE! No status information is shown on the page during the call.

The web interface, *cont...*

The web interface allows for remote administration of the system.

Open a web browser and enter the IP address of the codec. From this page you have the following menu options:

- System info
- Upgrade software
- Advanced configuration
- Wallpaper
- Call
- **Upload certificates**
- XML files
- Logs
- Add release key

The SSL Certificates page

TANDBERG C60

System info
 Upgrade software
 Advanced configuration
 Wallpaper
 Call
Upload certificates
 XML files
 Logs
 Add release key

SSL Certificate

HTTPS certificate (PEM format):

Private key (PEM format):

Passphrase:

About certificates

To install a certificate, you will need:

- HTTPS certificate (.PEM format)
- ROOT certificate (.PEM format)
- Private key (.PEM format)
- Passphrase (optional)

How to upload the certificate

1. Contact your system administrator to obtain the required files (.PEM format).
2. Click **Browse...** and locate the certificate files (.PEM)
3. Enter the **Passphrase** (optional).
4. Click the **Upload** button to install the certificates to the codec.

The web interface, *cont...*

The web interface allows for remote administration of the system.

Open a web browser and enter the IP address of the codec. From this page you have the following menu options:

- System info
- Upgrade software
- Advanced configuration
- Wallpaper
- Call
- Upload certificates
- **XML files**
- Logs
- Add release key

The XML files page

The screenshot shows the TANDBERG C60 web interface. The title bar reads "TANDBERG C60". On the left is a navigation menu with the following items: System info, Upgrade software, Advanced configuration, Wallpaper, Call, Upload certificates, XML files (highlighted in orange), Logs, and Add release key. The main content area is titled "XML Files" and contains a bulleted list of links: Configuration, Status, Command, Directory, Valuespace, and Documentation.

Configuration

The Configuration file gives an overview of the system settings, which are controlled from the Advanced configuration menu or from the API. The configuration commands are structured in a hierarchy, making up a database of system settings.

Status

The status information is structured in a hierarchy, making up a database constantly being updated by the system to reflect system and process changes.

Command

The Command file gives an overview of the commands available to instruct the system to perform an action and are issued from the API. A Command type command is usually followed by a set of parameters to specify how the given action is to be executed.

Directory

The Directory file will be described later.

Valuespace

The Valuespace gives an overview of all the available value spaces.

Documentation

The Documentation file will be described later.

The web interface, cont...

The web interface allows for remote administration of the system.

Open a web browser and enter the IP address of the codec. From this page you have the following menu options:

- System info
- Upgrade software
- Advanced configuration
- Wallpaper
- Call
- Upload certificates
- XML files
- **Logs**
- Add release key

The Logs page

TANDBERG C60

System info

Upgrade software

Advanced configuration

Wallpaper

Call

Upload certificates

XML files

Logs

Add release key

Logs

Current log files

Historical log files

The log files

The log files are TANDBERG specific debug files which may be required by TANDBERG in the need of technical support.

Historical log files

Time stamped historical log files. Click on a file and follow the instructions in the dialog box to save the application file.

Current log files

Time stamped event log files. Click on a text file to view the file or follow the instructions in the dialog box to save an application file.

Index of /log/

Name	Last Modified	Size	Type
Parent Directory/		-	Directory
log.tar.gz	2009-Jul-07 15:37:48	22.2K	application/x-gzip
log.tar.gz.0	2009-Jul-07 15:37:48	22.2K	application/x-gzip
log.tar.gz.1	2008-Nov-20 15:04:44	6.6K	application/x-gzip
log.tar.gz.2	2008-Nov-20 15:14:50	17.9K	application/x-gzip
log.tar.gz.3	2009-Feb-10 09:19:33	73.3K	application/x-gzip
log.tar.gz.4	2009-Feb-10 09:21:38	18.2K	application/x-gzip
log.tar.gz.5	2009-Feb-10 10:03:37	20.8K	application/x-gzip
log.tar.gz.6	2009-Feb-10 12:47:37	73.9K	application/x-gzip
log.tar.gz.7	2009-Feb-10 14:23:41	56.4K	application/x-gzip
log.tar.gz.8	2009-Feb-12 13:30:57	190.2K	application/x-gzip
log.tar.gz.9	2009-Feb-13 14:49:04	81.9K	application/x-gzip

lighttpd/1.4.20

Index of /eventlog/

Name	Last Modified	Size	Type
Parent Directory/		-	Directory
application.log	2009-Jul-22 08:48:51	644.9K	text/plain
application.log.save	2009-Jul-17 09:35:57	1.0M	application/o
application.log.truncated	2009-Jul-21 07:01:06	0.1K	application/o
audio0.log	2009-Jul-15 15:32:15	2.0K	text/plain
audio1.log	2009-Jul-15 15:32:10	1.5K	text/plain
audio2.log	2009-Jul-15 15:32:10	1.5K	text/plain
audio3.log	2009-Jul-16 12:53:29	1.7K	text/plain
audio4.log	2009-Jul-15 15:32:10	1.5K	text/plain
main.log	2009-Jul-22 08:48:00	23.7K	text/plain
osd5.log	2009-Jul-22 08:48:05	13.4K	text/plain
scriptbuffer.xml	2009-Jul-22 08:48:01	12.2K	application/x
statedump.xml	2009-Jul-22 08:48:01	20.3K	application/x
video0.log	2009-Jul-22 08:47:33	1.3K	text/plain
video1.log	2009-Jul-22 08:47:36	2.0K	text/plain
video2.log	2009-Jul-15 15:32:09	1.2K	text/plain
video3.log	2009-Jul-15 15:32:10	1.2K	text/plain
video4.log	2009-Jul-15 15:32:09	1.2K	text/plain
video5.log	2009-Jul-15 15:32:09	1.2K	text/plain

The web interface, cont...

The web interface allows for remote administration of the system.

Open a web browser and enter the IP address of the codec. From this page you have the following menu options:

- System info
- Upgrade software
- Advanced configuration
- Wallpaper
- Call
- Upload certificates
- XML files
- Logs
- **Add release key**

The Add release key page

TANDBERG C60

System info
Upgrade software
Advanced configuration
Wallpaper
Call
Upload certificates
XML files
Logs
Add release key

Add release key

The release key

Contact your TANDBERG representative to obtain the release key.

TANDBERG DNAM for Profile 42"/52"

The TANDBERG DNAM – Digital Natural Audio Module – is built on two specially designed and separate modules, the amplifier and the loudspeaker cabinet.

The DNAM Loudspeaker Cabinet

- 3-way Center Loudspeaker system
- Frequency range 50Hz - 20kHz
- 2 x 100 mm low- and midrange loudspeaker 8 Ohms nominal, excellent quality (SEAS Prestige series)
- 1 x 25mm dome tweeter, 6 ohms nominal, excellent quality
- Active crossover filtered audio signals received from DNAM amplifier
- Long time max power 70 Watt on all loudspeakers
- Enclosed MDF loudspeaker cabinet

Integrated Left / Right Stereo Loudspeaker

Stereo Loudspeaker System, each side has:

- 1 x 90 mm fullrange loudspeaker, 8 Ohms nominal, excellent quality
- Frequency range 70 Hz - 20 kHz
- Enclosed MDF Loudspeaker cabinet

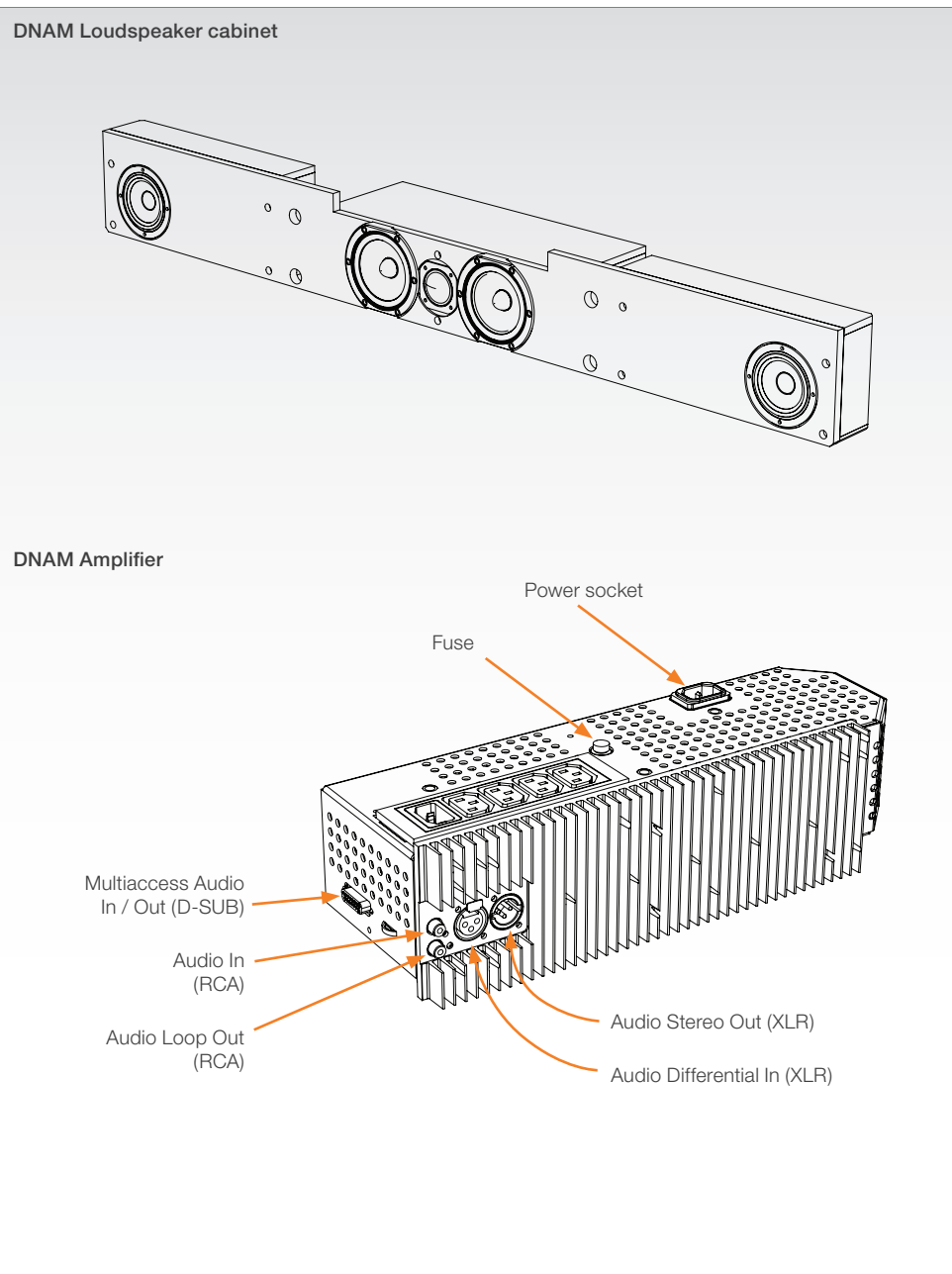

The DNAM Amplifier

- 3 x 50W continuous average Center Output Power (load specified by DNAM Center Loudspeakers)
- 2 x 50W continuous average Stereo Output Power (load specified by DNAM Stereo Loudspeakers)
- Full dynamic range for audio (20Hz–20kHz)
- Digital Signal Processing and Filtering on all channels for best audio detail clarity
- Digital Crossover Filtering on center channels
- In/out:
 - Audio In - SPDIF (stereo) or Analog (mono), using the same connector.
 - Audio Differential In - (female XLR pinout: 1 - GND, 2 – Signal (+), 3 – Signal (-))
 - Audio Loop Out - line out directly from the input, always analog even with SPDIF in.
 - Audio Stereo Out - (male XLR, common GND configuration)
- Fuse 2A 250V Slow, 5 x 20mm, Littelfuse type 215002. Push and twist anti-clockwise to release.

TANDBERG DNAM for Profile 65”

The TANDBERG DNAM – Digital Natural Audio Module – is built on two specially designed and separate modules, the amplifier and the loudspeaker cabinet.

The DNAM Loudspeaker Cabinet

- 3-way Center Speaker system
- Frequency range 50Hz - 20kHz
- 2 x 100mm low- and midrange loudspeakers, 8 ohms nominal, excellent quality (SEAS Excel series)
- 1 x 25mm dome tweeter, 6 ohms nominal, high quality
- Crossover filtered audio signals received from DNAM amplifier
- Long time max power 70 Watt on all loudspeakers
- Enclosed MDF speaker cabinet

Integrated Stereo Speaker

2-way Stereo Speaker System, each side has:

- 1 x 100mm low- and midrange loudspeaker, 8 ohms nominal, excellent quality (SEAS Excel series)
- 1 x 25mm dome tweeter, 6 ohms nominal, high quality
- Passive crossover filter
- Frequency range 70 Hz - 20 kHz
- Long time max power 70 Watt
- Enclosed MDF speaker cabinet

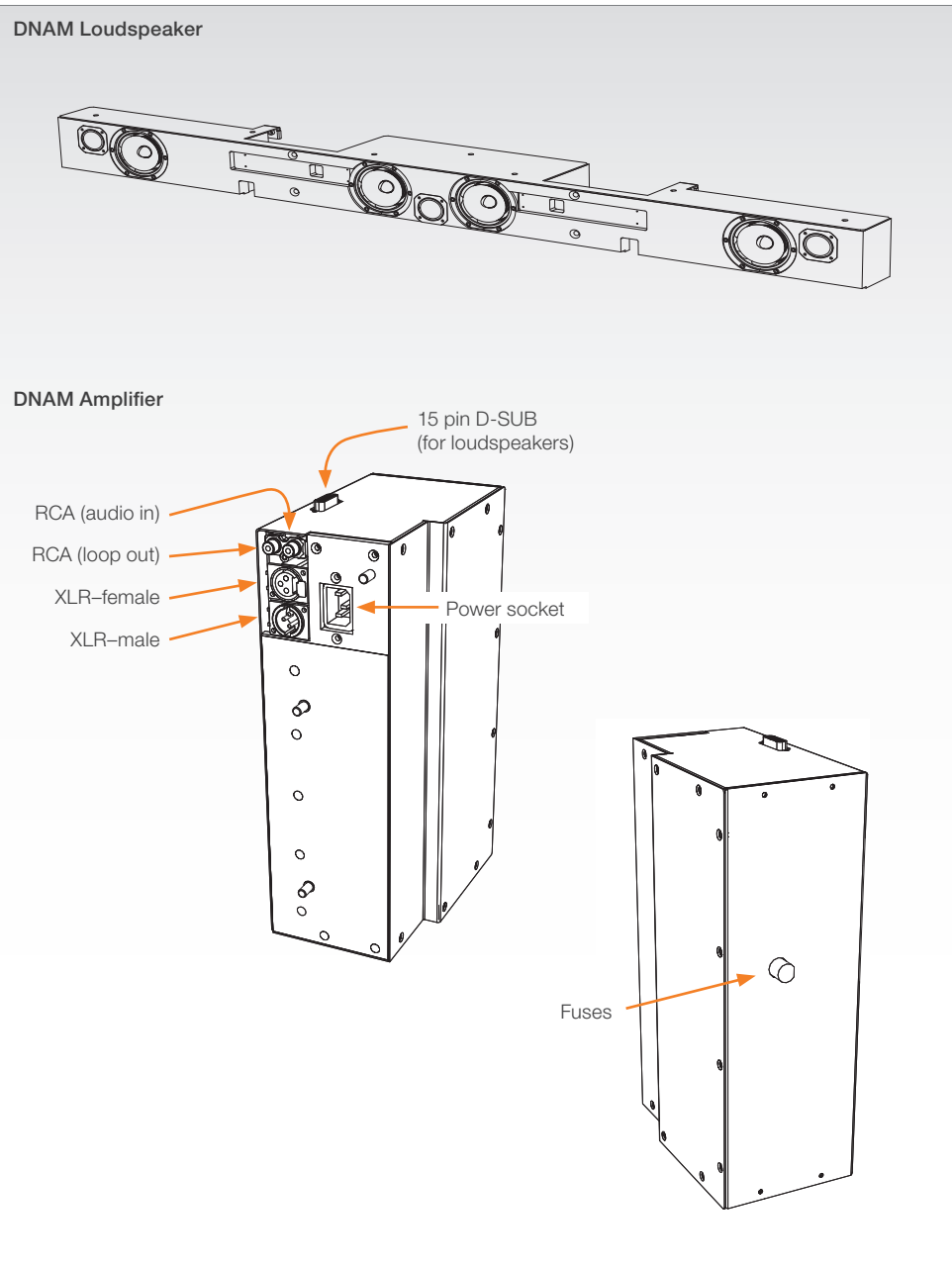

The DNAM Amplifier

- 3 x 50W continuous average Center Output Power (load specified by DNAM Center Speakers).
- 2 x 50W continuous average Stereo Output Power (load specified by TANDBERG Loudspeaker Stereo Kit).
- Full dynamic range for audio (high fidelity range) or Integrated stereo speakers.
- Digital Signal Processing and Filtering on all channels for best audio detail clarity.
- Digital Crossover Filtering on center channels.
- In/out:
 - Audio In - SPDIF (stereo) or Analog (mono), using the same connector.
 - Differential In - (female XLR pinout: 1 - GND, 2 - Signal (+), 3 - Signal (-))
 - Loop Out - line out directly from the input, always analog even with SPDIF in.
 - Stereo Out - (male XLR, common GND configuration)
- Fuse 2A 250V Slow, 5 x 20mm, Littelfuse type 215002.

Supported RFCs in SIP

The RFC (Request for Comments) series contains technical and organizational documents about the Internet, including the technical specifications and policy documents produced by the Internet Engineering Task Force (IETF).

Current RFCs and drafts supported in SIP

- RFC 1889 RTP: A Transport Protocol for Real-time Applications
- RFC 2190 RTP Payload Format for H.263 Video Streams
- RFC 2327 SDP: Session Description Protocol
- RFC 2396 Uniform Resource Identifiers (URI): Generic Syntax
- RFC 2429 RTP Payload Format for the 1998 Version of ITU-T Rec. H.263 Video (H.263+)
- RFC 2617 Digest Authentication
- RFC 2782 DNS RR for specifying the location of services (DNS SRV)
- RFC 2833 RTP Payload for DTMF Digits, Telephony Tones and Telephony Signals
- RFC 2976 The SIP INFO Method
- RFC 3016 RTP Payload Format for MPEG-4 Audio/Visual Streams
- RFC 3047 RTP Payload Format for ITU-T Recommendation G.722.1
- RFC 3261 SIP: Session Initiation Protocol
- RFC 3262 Reliability of Provisional Responses in SIP
- RFC 3263 Locating SIP Servers
- RFC 3264 An Offer/Answer Model with SDP
- RFC 3311 UPDATE method
- RFC 3361 DHCP Option for SIP Servers
- RFC 3420 Internet Media Type message/sipfrag
- RFC 3515 Refer method
- RFC 3550 RTP: A Transport Protocol for Real-Time Applications
- RFC 3581 Symmetric Response Routing
- RFC 3605 RTCP attribute in SDP
- RFC 3711 The Secure Real-time Transport Protocol (SRTP)
- RFC 3840 Indicating User Agent Capabilities in SIP
- RFC 3890 A Transport Independent Bandwidth Modifier for SDP
- RFC 3891 The SIP "Replaces" Header
- RFC 3892 Referred-By Mechanism
- RFC 3960 Early Media
- RFC 3984 RTP Payload Format for H.264 Video
- RFC 4028 Session Timers in SIP
- RFC 4145 TCP-Based Media Transport in the SDP
- RFC 4568 SDP: Security Descriptions for Media Streams

- RFC 4574 The Session Description Protocol (SDP) Label Attribute
- RFC 4582 The Binary Floor Control Protocol
- RFC 4585 Extended RTP Profile for RTCP-Based Feedback
- RFC 4587 RTP Payload Format for H.261 Video Streams
- RFC 4629 RTP Payload Format for ITU-T Rec. H.263 Video
- RFC 5168 XML Schema for Media Control
- RFC 4796 The SDP Content Attribute
- RFC 4583 SDP Format for BFCP Streams
- RFC 5589: SIP Call Control Transfer
- draft-ietf-avt-rtp-h264-rcdo-02
- draft-ietf-avt-rtp-rfc3984bis-06
- draft-ietf-sip-outbound-20: Managing Client Initiated Connections

Media capabilities supported in SIP

The audio and video media capabilities supported in SIP are the same as for H.323.

China RoHS table

This product complies with the Chinese RoHS.

产品中有毒有害物质表

部件名称	有毒有害物质或元素					
	铅	汞	镉	六价铬	多溴联苯	多溴二苯醚
金属部件	X	O	O	O	O	O
印刷电路板及组件	X	O	O	O	O	O
线缆和线缆组装	X	O	O	O	O	O
显示器（包括照明灯）	X	X	O	O	O	O

说明:

O: 表示该有毒有害物质在此部件所有均质材料中的含量均在中国标准《电子信息产品中有毒有害物质的限量要求》(SJ/T 11363-2006) 所规定的限量要求以下。

X: 表示该有毒有害物质至少在该部件的某一均质材料中的含量超出中国标准《电子信息产品中有毒有害物质的限量要求》(SJ/T 11363-2006) 所规定的限量要求。

注意: 在所售产品中未必包含所有上述所列部件。

除非在产品上有另外特别的标注，以下标志为针对所涉及产品的环保使用期限标志。环保使用期限只适用于产品在产品手册中所规定的使用条件。



CE Declaration for TANDBERG Profile

For an official, signed version of the document, or details regarding documentation from the technical construction file, please contact TANDBERG.

EC Declaration of conformity				
MANUFACTURER:	TANDBERG Telecom AS	TANDBERG Telecom AS	TANDBERG Telecom AS	TANDBERG Telecom AS
PRODUCT NAME:	PROFILE 42	PROFILE 52	PROFILE 52 Dual	TANDBERG Telepresence T1 TANDBERG Profile 65 Dual C90 PROFILE 65 w. C60
TYPE NUMBER:	TTC60-12	TTC60-13	TTC60-14	TTC60-11
DESCRIPTION:	Video Conferencing Equipment	Video Conferencing Equipment	Video Conferencing Equipment	Video Conferencing Equipment
DIRECTIVES: This equipment complies with.	LVD 2006/95/EC EMC 2004/108/EC	LVD 2006/95/EC EMC 2004/108/EC	LVD 2006/95/EC EMC 2004/108/EC	LVD 2006/95/EC EMC 2004/108/EC
HARMONIZED STANDARDS: Applied in order to verify compliance with directives.	EN 60950-1:2006 EN 55022 (2006) EN 55024 (1998) + A1 (2001) + A2 (2003) EN 61000-3-2 (2006) EN 61000-3-3 (1995) + A1 (2001) + A2 (2005)	EN 60950-1:2006 EN 55022 (2006) EN 55024 (1998) + A1 (2001) + A2 (2003) EN 61000-3-2 (2006) EN 61000-3-3 (1995) + A1 (2001) + A2 (2005)	EN 60950-1:2006 EN 55022 (2006) EN 55024 (1998) + A1 (2001) + A2 (2003) EN 61000-3-2 (2006) EN 61000-3-3 (1995) + A1 (2001) + A2 (2005)	EN 60950-1:2006 EN 55022 (2006) EN 55024 (1998) + A1 (2001) + A2 (2003) EN 61000-3-2 (2006) EN 61000-3-3 (1995) + A1 (2001) + A2 (2005)
TEST REPORTS and CERTIFICATES ISSUED BY:	Report/Certificates No: LVD (Nemko AS) 118330, 119330, 120725 and 123953 EMC (Nemko AS) E09640.00 (123774)	Report/Certificates No: LVD (Nemko AS) 118330 and 119330 EMC (Nemko AS) E08604.00 (118330), E09630.00 (119330) R&TTE (Comlab) 03/559/3, 03/559/4, 03/560/3, 03/560/4	Report/Certificates No: LVD (Nemko AS) 118330, 119330, 120725, 123953, 126466 EMC (Nemko AS) E09682.00 (128465), E09634.00 (123042) R&TTE (Comlab) 03/559/3, 03/559/4, 03/560/3, 03/560/4	Report/Certificates No: LVD (Nemko AS) 121982, LVD (Nemko AS) 136312 (Profile 65 w. C60 only) EMC (Nemko AS) E08564.00, EMC (Nemko AS) E08564.01 (Profile 65 w. C60 only)
TECHNICAL CONSTRUCTION FILE NO.:	X14474	X14475	X14539	X14383 rev. 3
YEAR WHICH THE CE-MARK WAS AFFIXED:	2009	2009	2009	2008 2009 (Profile 65 products)

Dimensions

Profile 42" with standalone foot
The dimensions in mm.

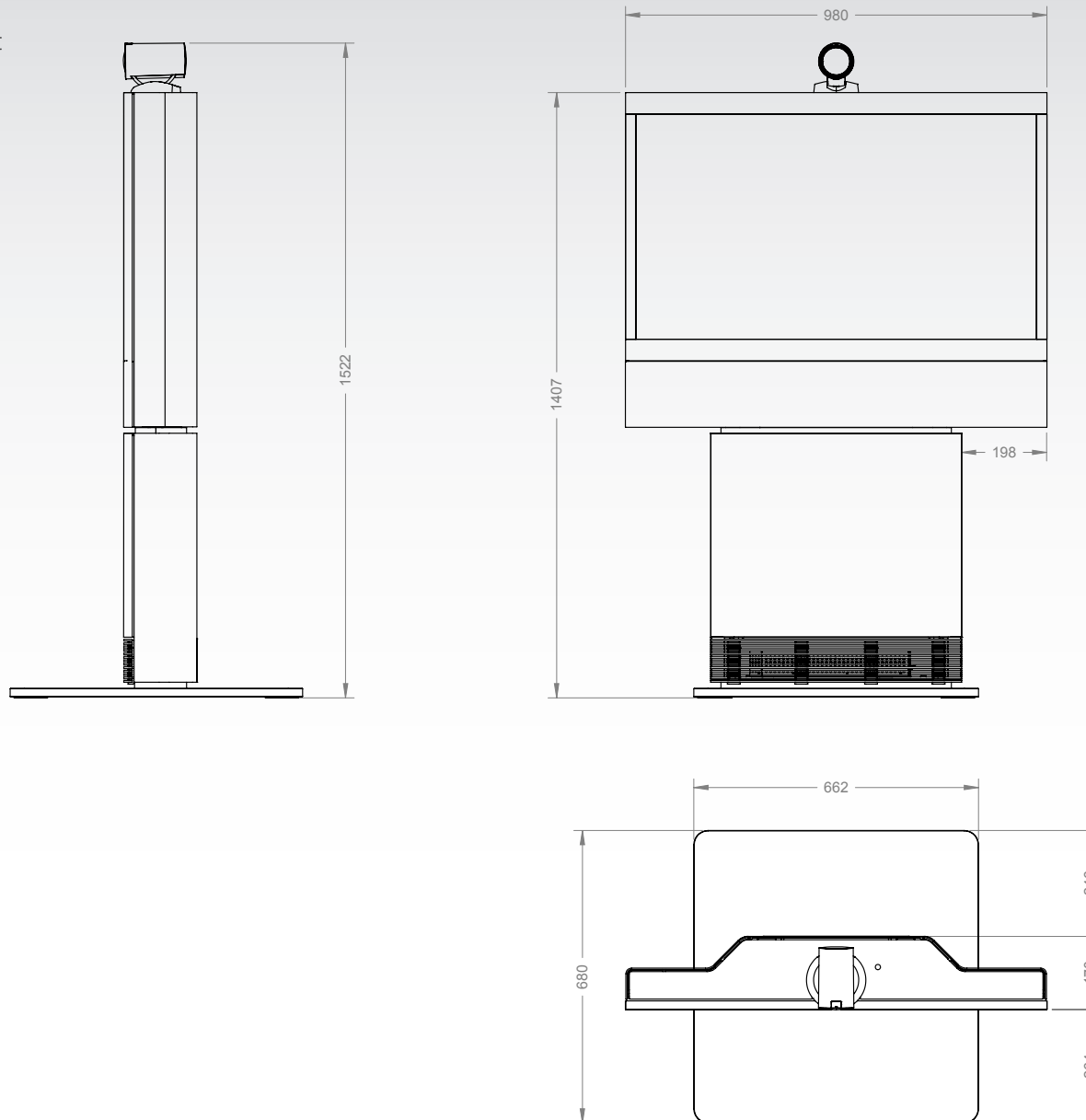

Dimensions

Profile 42" with wall mount foot
The dimensions in mm.

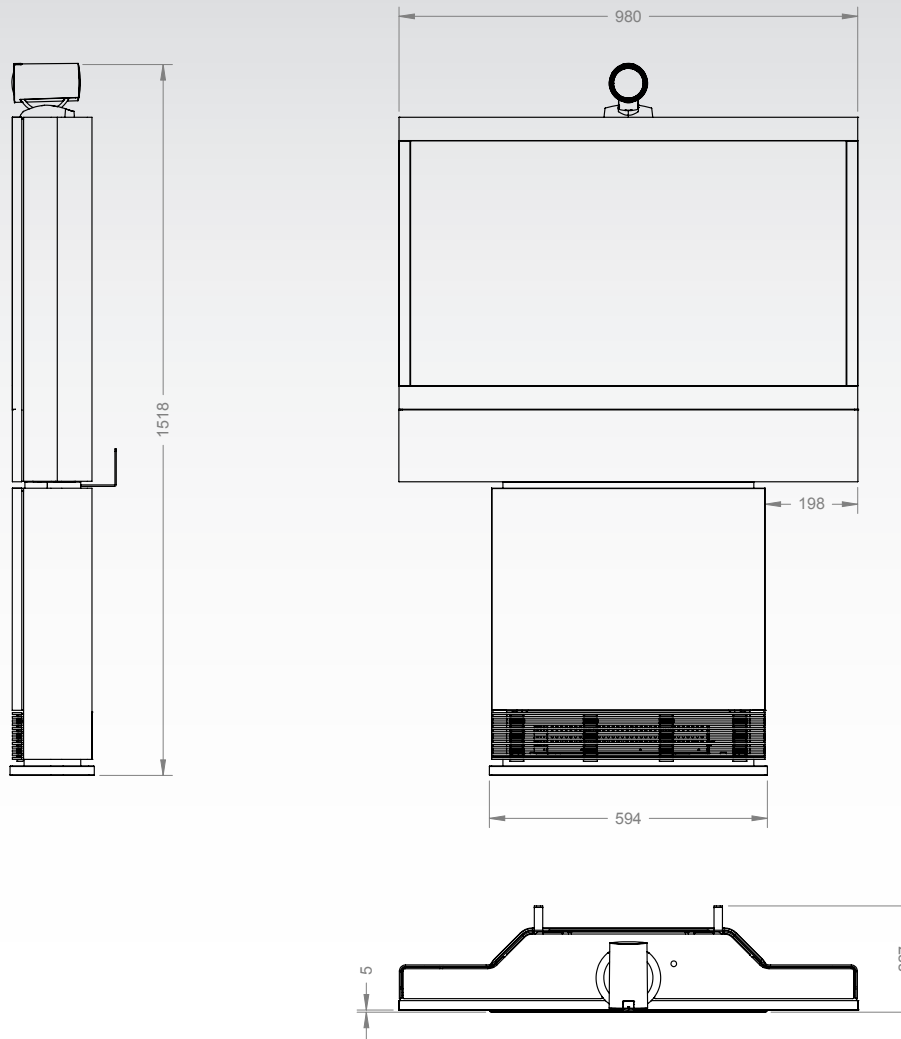

Dimensions

Profile 42" with wheelbase foot
The dimensions in mm.

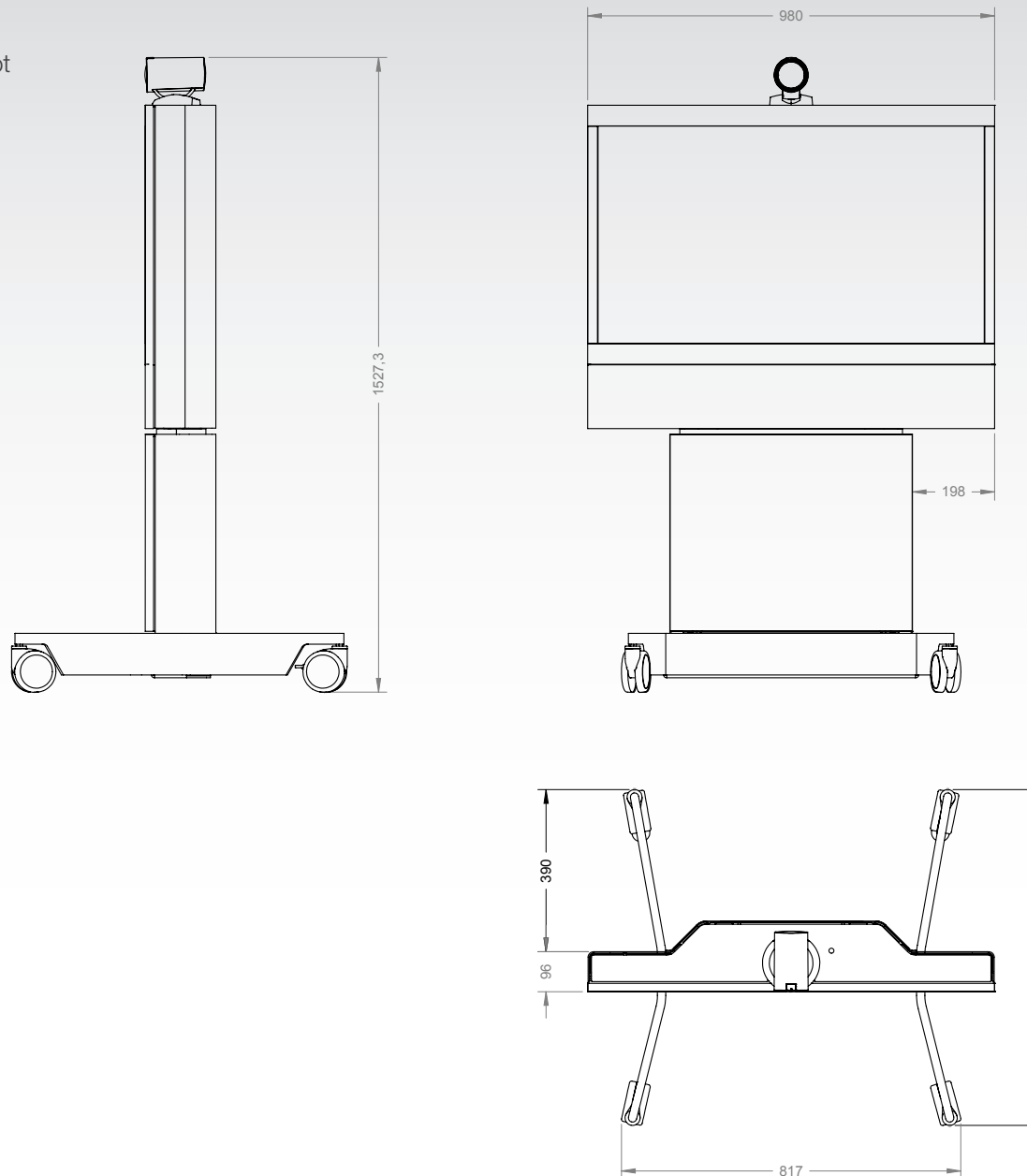

Dimensions

Profile 52" with standalone foot

The dimensions in mm.

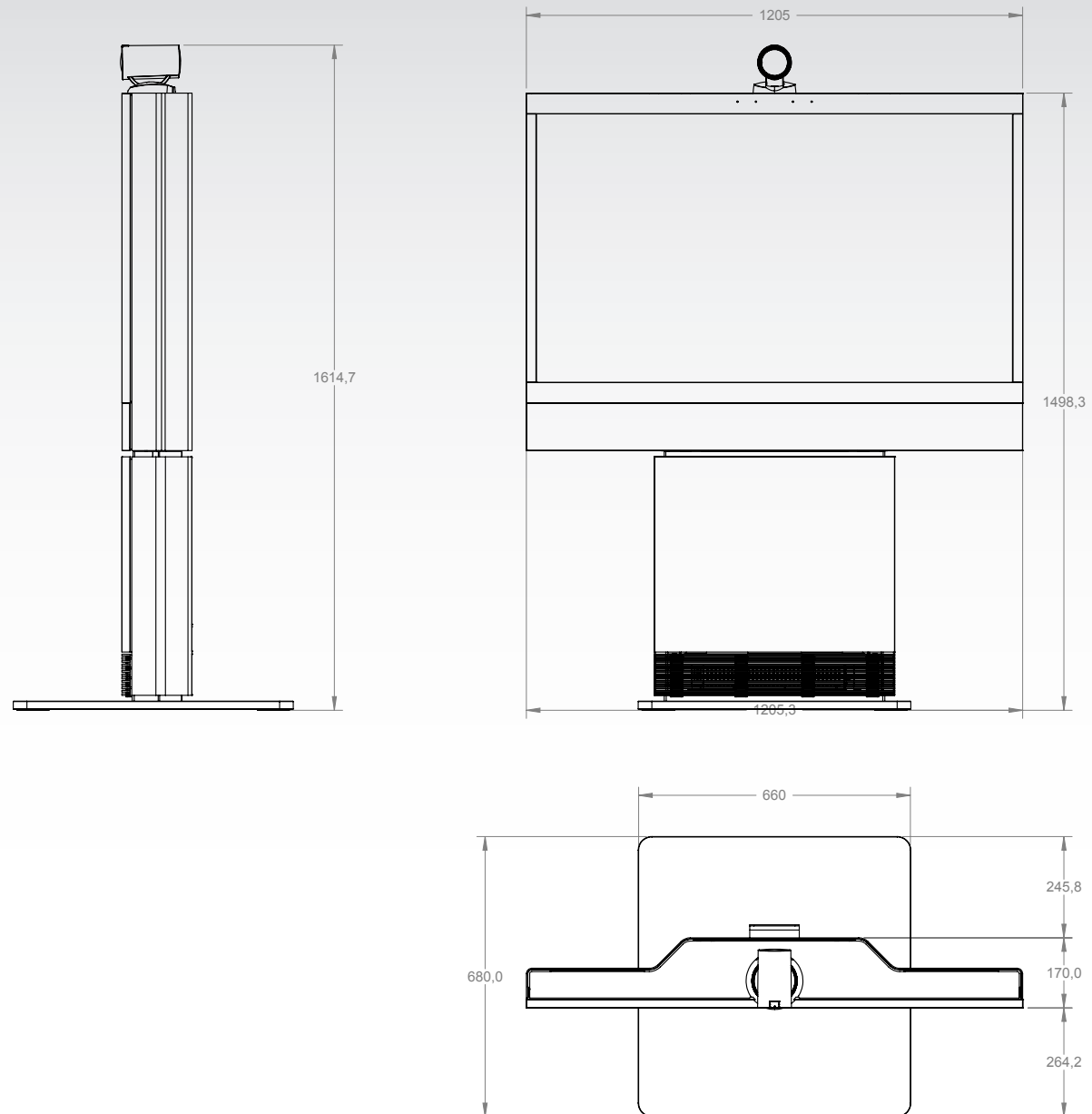

Dimensions

Profile 52" with wall mount foot
The dimensions in mm.

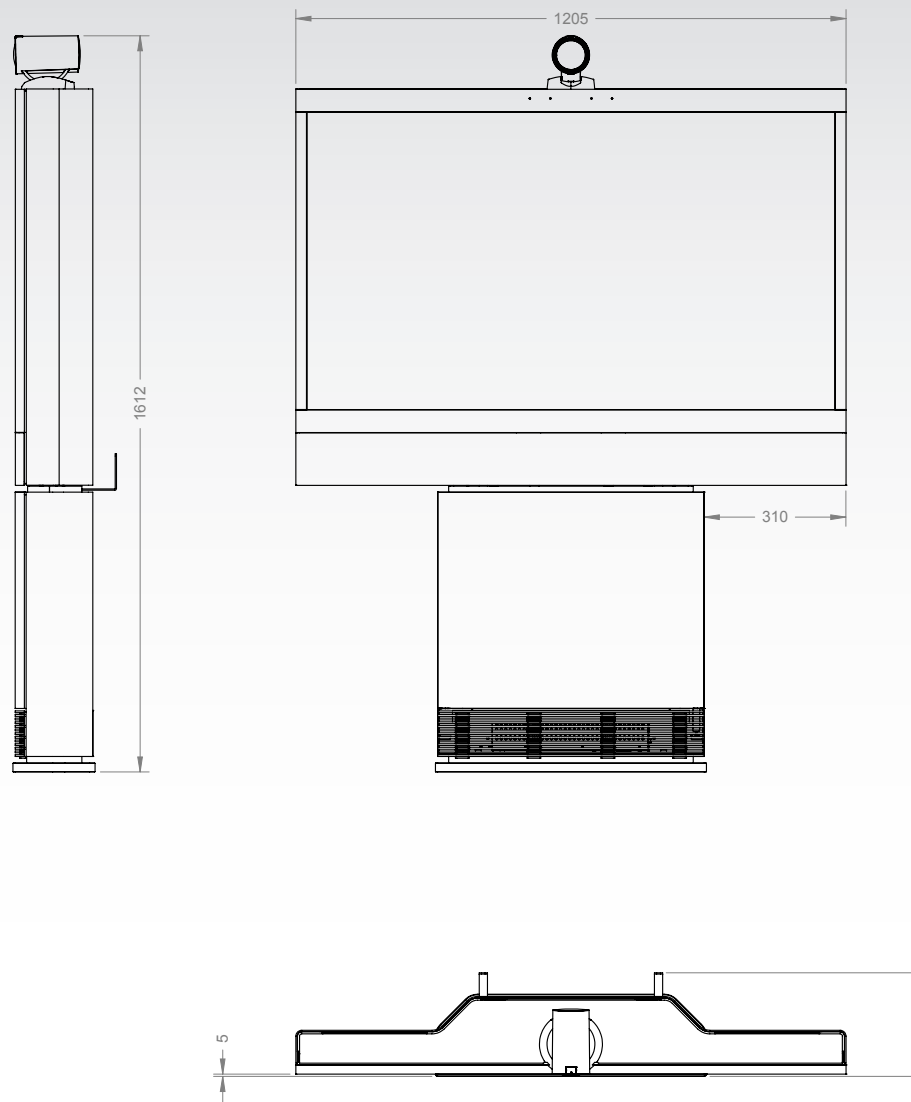

Dimensions

Profile 52" with wheelbase foot
The dimensions in mm.

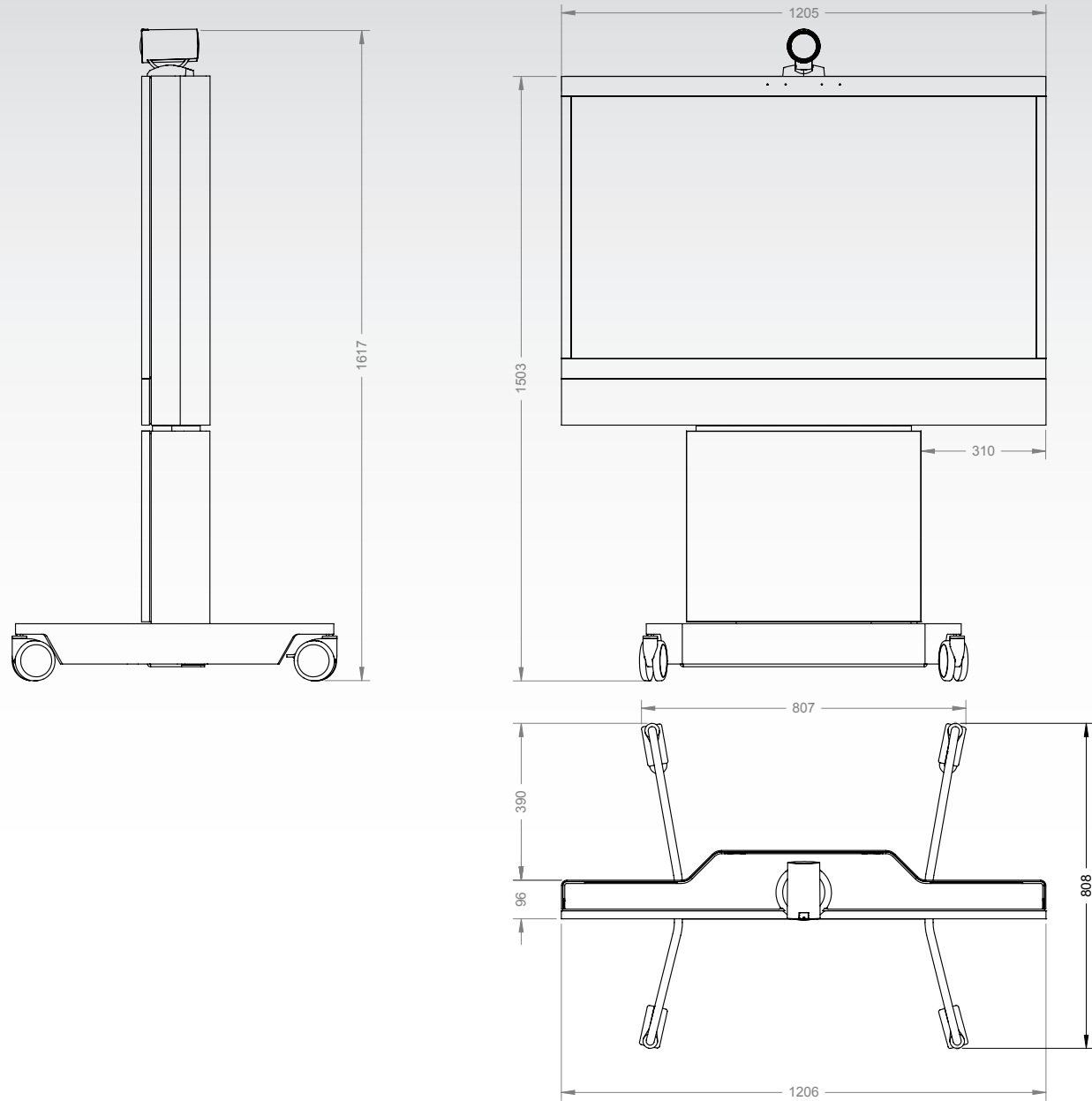

Dimensions

Profile 52" Dual with standalone foot

The dimensions in mm.

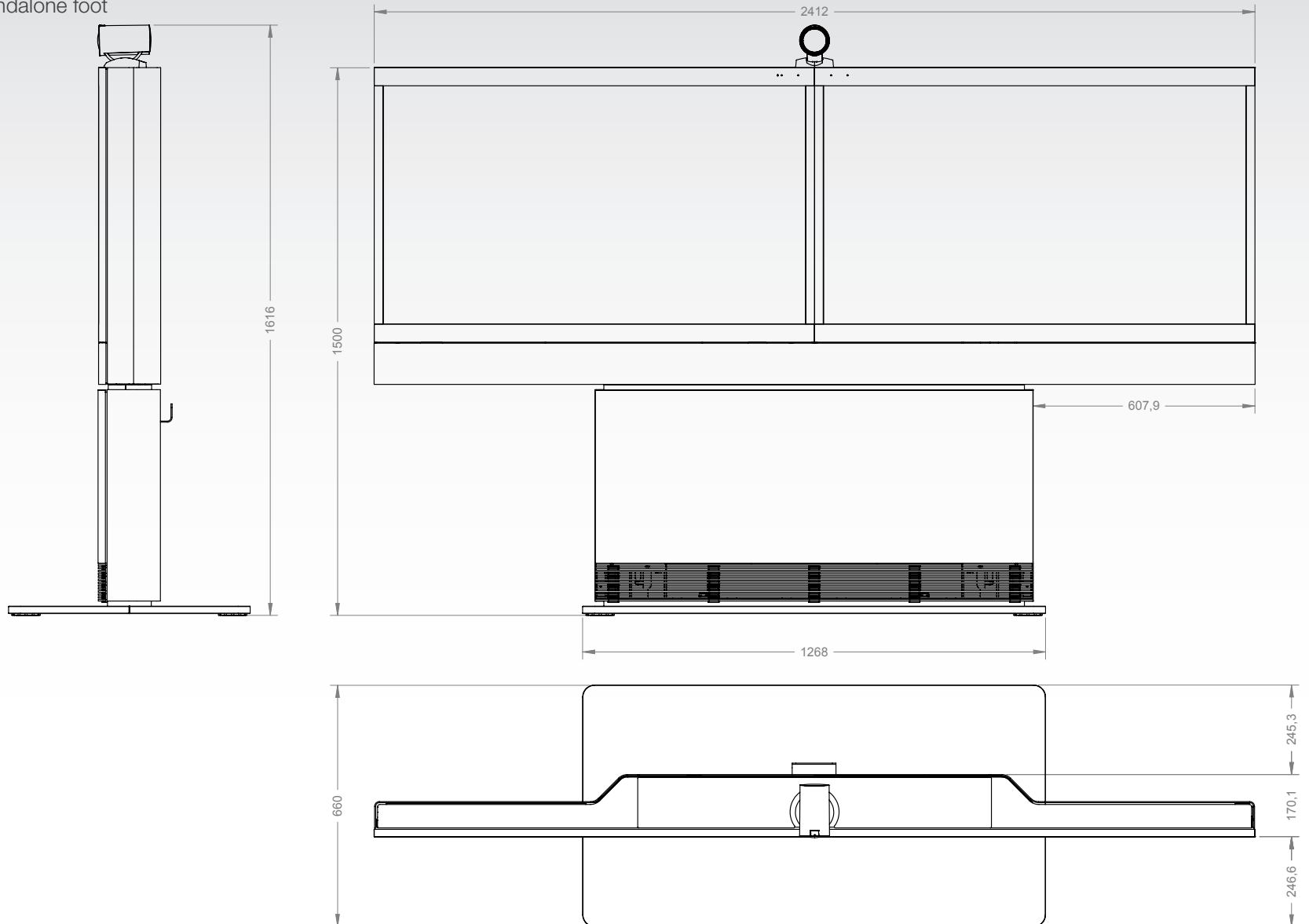

Profile wall mount setup

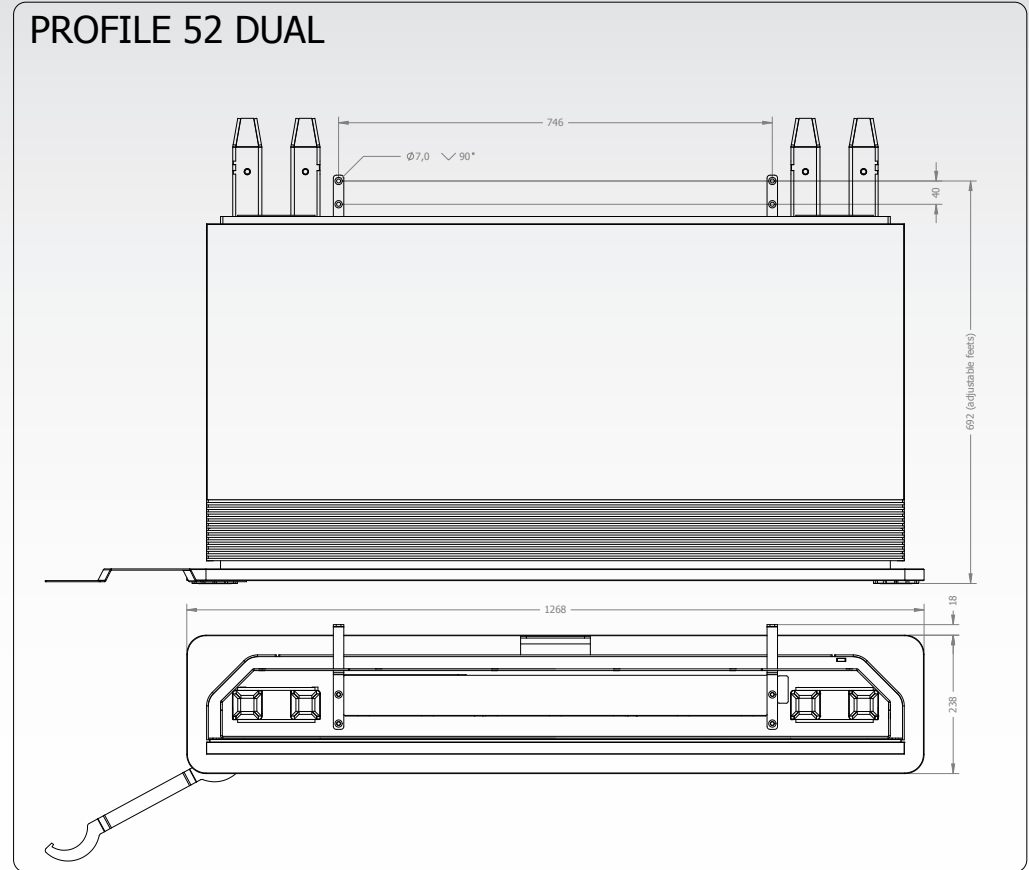
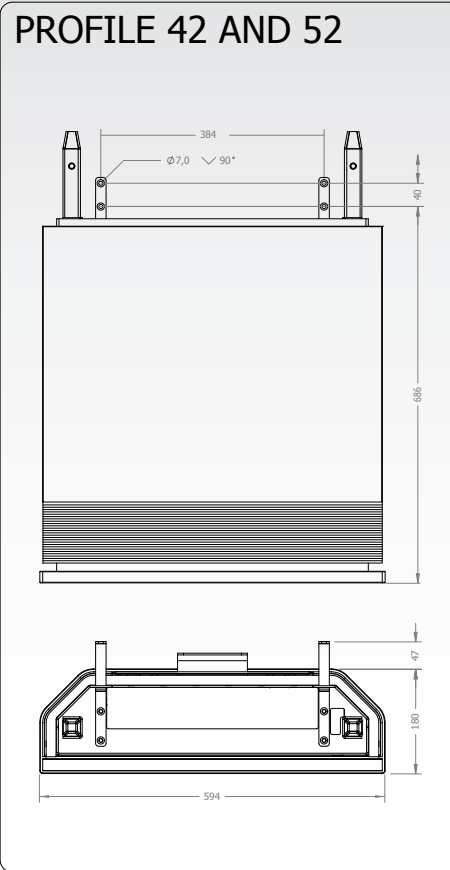
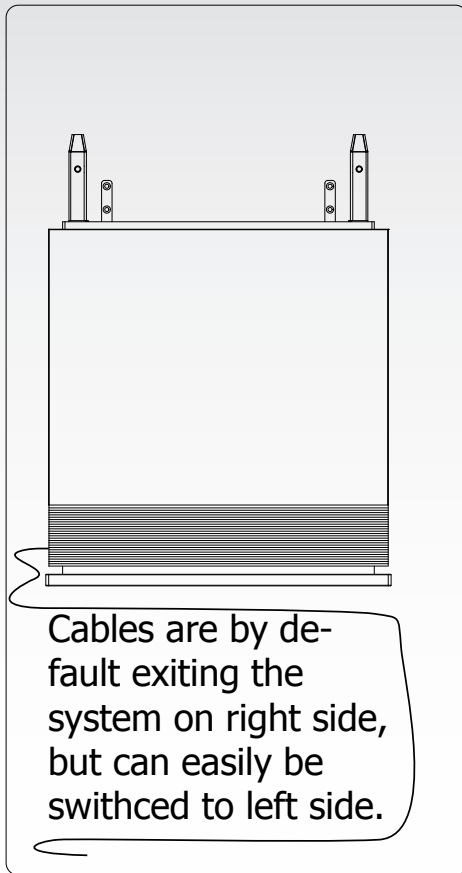

WARNING!

Due to the size and mass of this equipment, it is very important that the wall mount unit is safely installed according to the installation instructions and that the wall is able to safely support the product. It is highly recommended that the wall mounted system is installed by trained personnel

Mounting

Use the Allen key, which is found in the foot box, when fastening the wall brackets to the bottom module with four M6x10 screws
Place the bottom module by the wall, mark where to bolt the bracket and move away the bottom module

NOTE! Use a level to make sure the system is mounted in an upright position. Add a spacer between the wall bracket and the wall if necessary.

Add the suitable fixing device for the screws in the wall
Open the rear door and locate and connect the cables which are lead out of the system at the rear side (the door is not accessible when placed by the wall)
Place the bottom module by the wall and bolt it to the wall.

Dimensions

Profile 65" with standalone foot

The dimensions in mm.

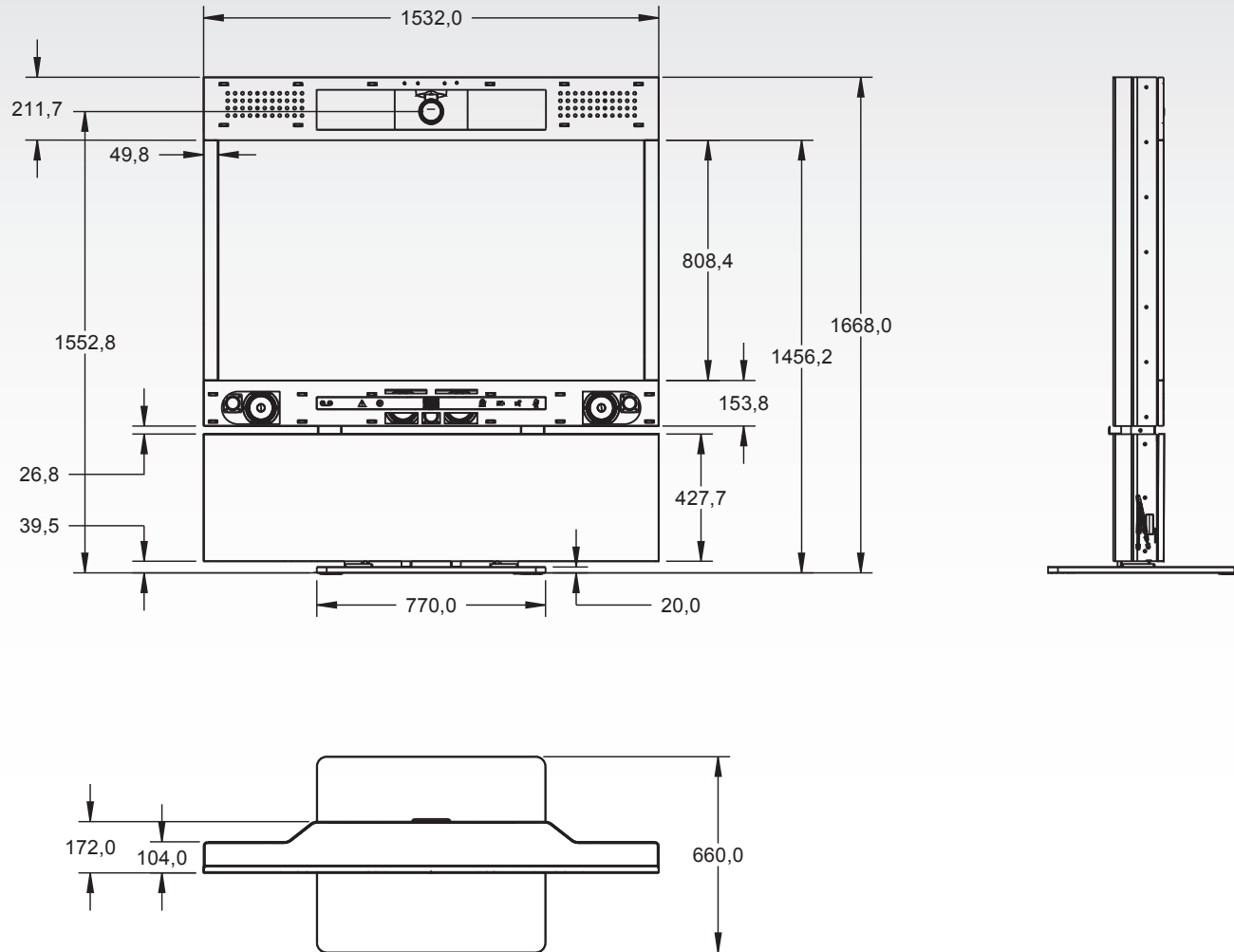

Dimensions

Profile 65" with wall mounting foot

The dimensions in mm.

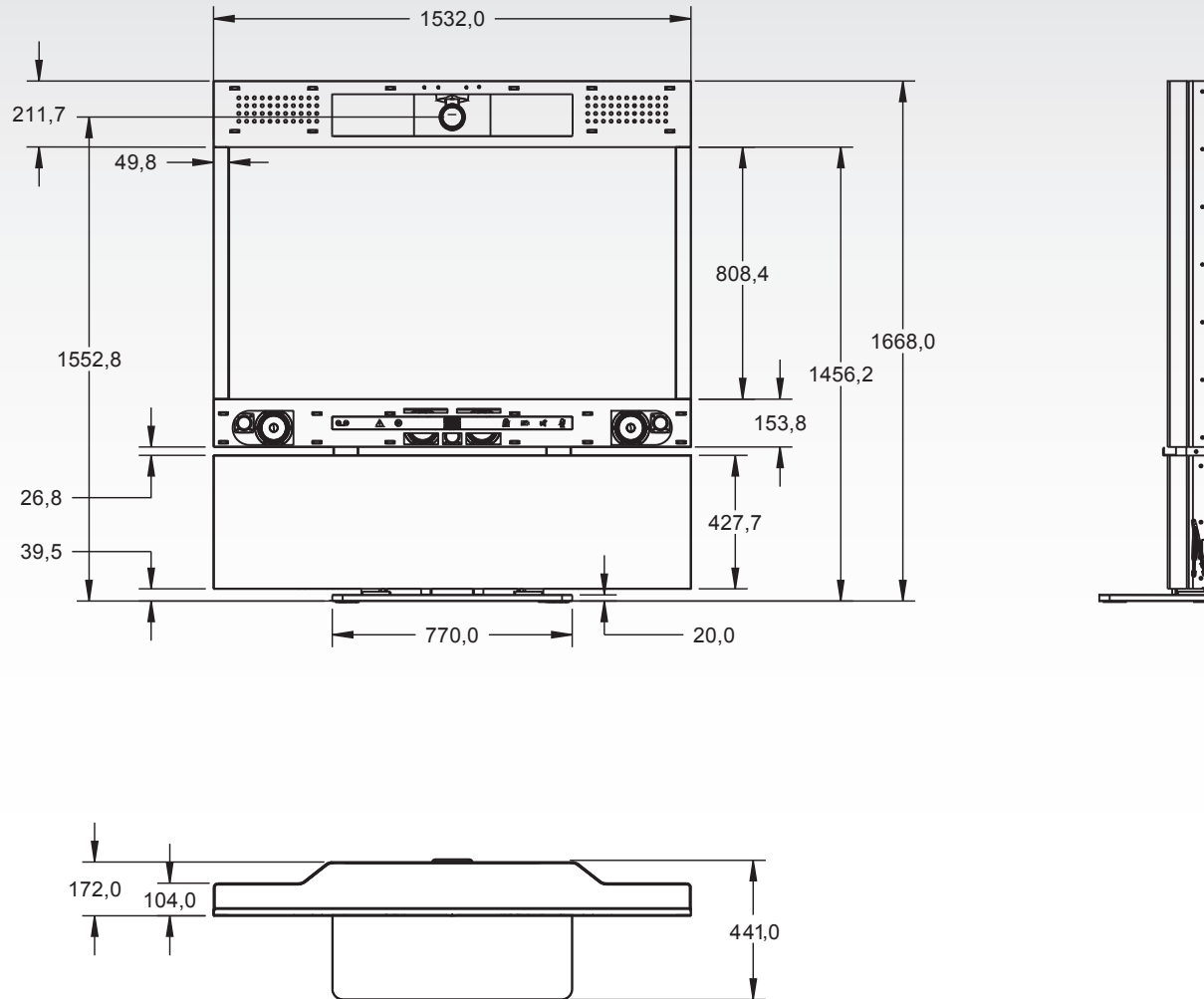

Dimensions

PrecisionHD 1080p camera

The dimensions in mm.

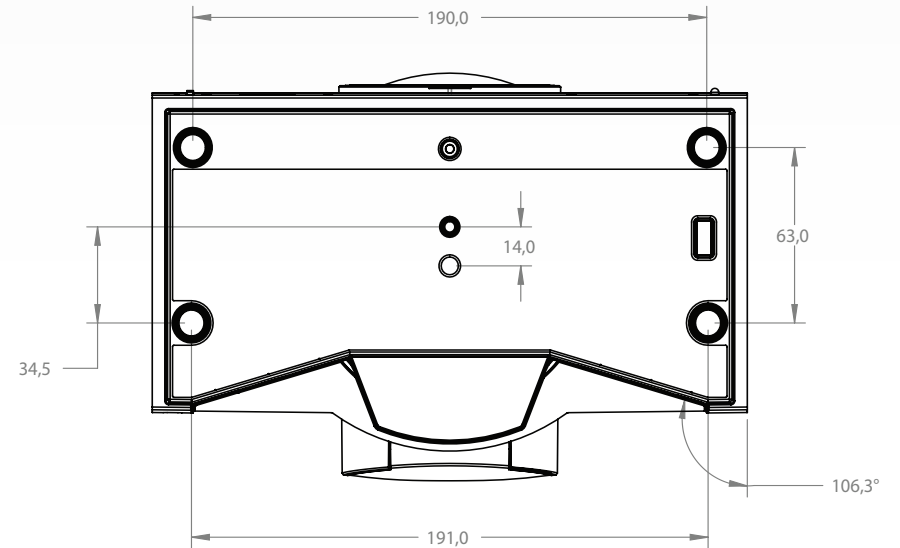
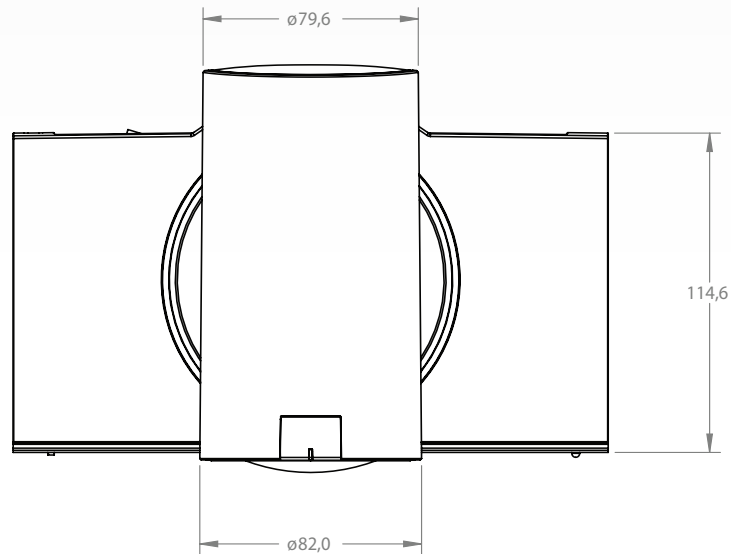
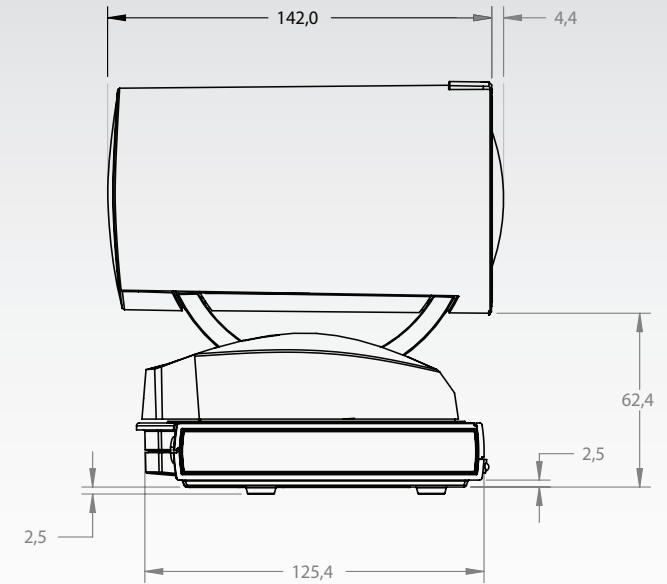
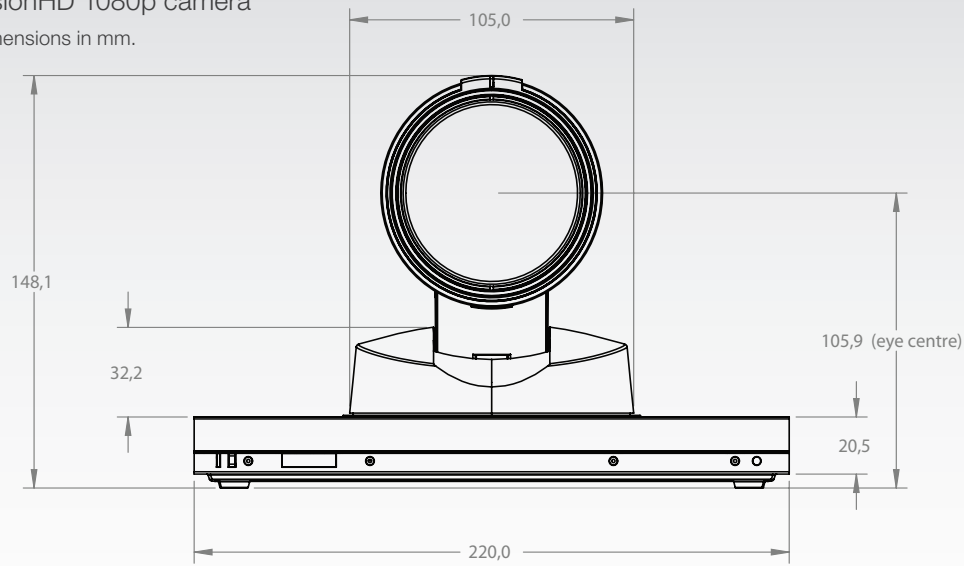

Technical specifications for Profile 42"/52"

UNIT DELIVERED COMPLETE WITH:

Full HD LCD display, Codec C60, remote control, PrecisionHD 1080p Camera, microphone (3x with single screen, 4x with dual screen), Digital Audio Module, integrated speakers and integrated cabling.

Choice of installation configuration: floor stand, wheel base or wall mount on pedestal.

Choice of screen size and configuration.

MONITOR Available with:

- 52" Full HD LCD, 16:9, 1080x1920 resolution
- 42" Full HD LCD, 16:9, 1080x1920 resolution

BASE Available with:

- Floor standing foot plate
- Wheel base (not available on 52" dual)
- Wall mount on pedestal

BANDWIDTH

- H.323/SIP up to 6 Mbps point-to-point
- H.323/SIP up to 10 Mbps Multisite*

FIREWALL TRAVERSAL

- TANDBERG Expressway™ Technology
- H.460.18, H.460.19 Firewall Traversal
- SIP ICE

VIDEO STANDARDS

- H.261, H.263, H.263+, H.264

VIDEO FEATURES

- Native 16:9 Widescreen
- Advanced Screen Layouts
- Intelligent Video Management
- Local Auto Layout

VIDEO INPUTS (5 INPUTS)

2 X HDMI inputs, supported formats:

- 1920 x 1080@60, 59.94 Hz (1080p60)
- 1920 x 1080@50 Hz (1080p50)
- 1920 x 1080@30, 29.97 Hz (1080p30)
- 1920 x 1080@25 Hz (1080p25)
- 1920 x 1080@24, 23.97 Hz (1080p24)
- 1920 x 1200@50 Hz (WUXGA)
- 1680 x 1050@60 Hz (WSXGA+)

- 1600 x 1200@50, 60 Hz (UXGA)
- 1440 X 900@60 Hz (WXGA+)
- 1400 x 1050@60, 75 Hz
- 1366 x 768@60 Hz
- 1360 x 768@60 Hz
- 1280 x 1024@60, 75, 85 Hz (SXGA)
- 1280 x 960@60, 85 Hz
- 1280 x 800@60 Hz (WXGA)
- 1280 x 768@60, 75, 85 Hz (WXGA)
- 1280 x 720@60, 59.94 Hz (720p60)
- 1280 x 720@50 Hz (720p50)
- 1152 x 864@75 Hz
- 1024 x 768@60, 70, 75, 85 Hz (XGA)
- 848 x 480@60 Hz
- 800 x 600@56, 60, 72, 75, 85 Hz (SVGA)
- 720 x 576@50 Hz (576p50)
- 720 x 480@60, 59.94 Hz (480p60)
- 640 x 480@60, 72, 75, 85 Hz (VGA)

2 x DVI-I inputs, supported formats:

Digital (DVI-D):

- Same as HDMI, ref. above.

Analog RGB (DVI-A):

- 1920 x 1080@60 Hz (1080p60)
- 1920 x 1200@50 Hz (WUXGA)
- 1680 x 1050@60 Hz (WSXGA+)
- 1600 x 1200@60 Hz (UXGA)
- 1440 x 900@60 Hz (WXGA+)
- 1400 x 1050@60, 75 Hz
- 1366 x 768@60 Hz
- 1360 x 768@60 Hz
- 1280 x 1024@60, 75, 85 Hz (SXGA)
- 1280 x 960@60, 85 Hz
- 1280 x 800@60 Hz (WXGA)
- 1280 x 768@60, 75, 85 Hz (WXGA)
- 1280 x 720@60 Hz (720p60)
- 1152 x 864@75 Hz
- 1024 x 768@60, 70, 75, 85 Hz (XGA)
- 848 x 480@60 Hz
- 800 x 600@56, 60, 72, 75, 85 Hz (SVGA)
- 720 x 576@50 Hz
- 720 x 480@60, 59.94 Hz (480p60)
- 640 x 480@60, 72, 75, 85 Hz (VGA)

Analog YPbPr (DVI-A):

- 1920 x 1080@60 Hz (1080p60)

- 1920 x 1080@50 Hz (1080p50)
- 1920 x 1080@30 Hz (1080p30)
- 1920 x 1080@25 Hz (1080p25)
- 1280 x 720@60 Hz (720p60)
- 1280 x 720@50 Hz (720p50)
- 1280 x 720@30 Hz (720p30)
- 720 x 576@50 Hz (576p50)
- 720 x 480@60 Hz (480p60)

Extended Display Identification Data (EDID)

1 X Composite input (BNC connector), supported formats:

- PAL/NTSC

VIDEO OUTPUTS (2 OUTPUTS)

1 X HDMI output, 1 X DVI-I output, supported formats:

- 1920 x 1080@60 Hz (1080p60)
- 1920 x 1200@60Hz (WUXGA)
- 1600 x 1200@60 Hz (UXGA)
- 1366 x 768@60 Hz
- 1360 x 768@60 Hz
- 1280 x 720@60 Hz (720p60)
- 1280 x 1024@60 Hz (SXGA)
- 1280 x 768@60 Hz (WXGA)
- 1024 x 768@60 Hz (XGA)
- 800 x 600@60 Hz (SVGA)
- 640 x 480@60 Hz (VGA)

VESA Monitor Power Management

1 X Composite output (BNC connector), supported formats:

- PAL/NTSC

LIVE VIDEO RESOLUTIONS (ENCODE/DECODE)

- 176 x 144@30 fps (QCIF)
- 352 x 288@30 fps (CIF)
- 512 x 288@30 fps (w288p)
- 576 x 448@30 fps (448p)
- 768 x 448@30 fps (w448p)
- 704 x 576@30 fps (4CIF)
- 1024 x 576@30 fps (w576p)
- 640 x 480@30 fps (VGA)
- 800 x 600@30 fps (SVGA)
- 1024 x 768@30 fps (XGA)
- 1280 x 1024@30 fps (SXGA)
- 1280 x 720@30 fps (720p30)
- 1920 x 1080@30 fps (1080p30)*

- 1280 x 768@30 fps (WXGA)
- 1440 x 900@30 fps (WXGA+)
- 1680 x 1050@30 fps (WSXGA+)
- 1600 x 1200@30 fps (UXGA)
- 512 x 288@60 fps (w288p60)*
- 768 x 448@60 fps (w448p60)*
- 1024 x 576@60 fps (w576p60)*
- 1280 x 720@60 fps (720p60)*

AUDIO STANDARDS

- G.711, G.722, G.722.1, 64 bit & 128 bit MPEG4 AAC-LD, AAC-LD Stereo

AUDIO FEATURES

- CD-Quality 20KHz Mono and Stereo
- Four separate acoustic echo cancellers
- 4-port Audio mixer
- Automatic Gain Control (AGC)
- Automatic Noise Reduction
- Active lip synchronization
- ALD (Assistive Listening Devices) support with acoustic echo cancellation

AUDIO INPUTS (7 INPUTS)

- 4 x microphone, 48V phantom powered, XLR connector each with separate echo cancellers and noise reduction, all microphones can be set for balanced line level
- 2 x RCA/Phono, Line Level: Stereo PC input, configurable to 2 x RCA/Phono, Line Level: Mono auxiliary/DVD input
- 1 x HDMI, digital: Stereo PC/DVD inputs

AUDIO OUTPUTS (3 OUTPUTS)

- 2 x RCA/Phono, line level, stereo main audio, configurable to S/PDIF or 2 x RCA/Phono, line level, mono to recording device
- 1 x HDMI, digital, stereo main audio

DUAL STREAM

- H.239 (H.323) dual stream
- BFCP (SIP) dual stream
- Support for resolutions up to 1080p30 in both main stream and dual stream simultaneously

MULTISITE FEATURES*

- 4-way 720p30 High Definition SIP/H.323 MultiSite
- Full individual audio and video transcoding
- Individual layouts in MultiSite CP (Takes out SelfView)
- H.323/SIP/VoIP in the same conference
- Best Impression (Automatic CP Layouts)

Technical specifications for Profile 42"/52", cont...

- H.264, Encryption, Dual Stream from any site
- IP Downspeeding
- Dial in/Dial out
- Conference rates up to 10 Mbps

PROTOCOLS

- H.323
- SIP

EMBEDDED ENCRYPTION

- H.323/SIP point-to-point
- Standards-based: H.235 v2 & v3 and AES
- Automatic key generation and exchange
- Supported in Dual Stream

IP NETWORK FEATURES

- DNS lookup for service configuration
- Differentiated Services (QoS)
- IP adaptive bandwidth management (including flow control)
- Auto gatekeeper discovery
- Dynamic playout and lip-sync buffering
- H.245 DTMF tones in H.323
- Date and Time support via NTP
- Packet Loss based Downspeeding
- URI Dialing
- TCP/IP
- DHCP
- Direct DNS dialing

SECURITY FEATURES

- Management via HTTPS and SSH
- IP Administration Password
- Menu Administration Password
- Disable IP services
- Network Settings protection

NETWORK INTERFACES **

- 1 x LAN/Ethernet (RJ-45) 10/100/1000 Mbit

OTHER INTERFACES

- USB host for future usage
- USB device for future usage
- GPIO for future usage

PRECISIONHD 1080P CAMERA

- 1/3" CMOS
- 12 x zoom
- +15°/-25° tilt, +/- 90° pan
- 43.5° vertical field of view
- 72° horizontal field of view
- Focus distance 0.3m–infinity
- 1920 x 1080 pixels progressive @ 60fps
- Other formats supported (configurable through Dip-switch):
 - 1920 x 1080@60 Hz (HDMI only)
 - 1920 x 1080@50 Hz (HDMI only)
 - 1920 x 1080@30 Hz
 - 1920 x 1080@25 Hz
 - 1280 x 720@60 Hz
 - 1280 x 720@50 Hz
 - 1280 x 720@30 Hz
 - 1280 x 720@25 Hz
- Automatic or manual focus/brightness/white balance
- Far-end camera control
- Daisy-chain support (Visca protocol camera)
- Dual HDMI and HD-SDI output
- Upside-down mounting with automatic flipping of picture

SYSTEM MANAGEMENT

- Support for the TANDBERG Management Suite
- Total management via embedded SNMP, Telnet, SSH, XML, SOAP
- Remote software upload: via web server, SCP, HTTP, HTTPS
- 1 x RS-232 for local control and diagnostics
- Remote control and on-screen menu system

DIRECTORY SERVICES

- Support for Local directories (My Contacts)
- Corporate Directory
- Unlimited entries using Server directory supporting LDAP and H.350
- Unlimited number for Corporate directory (through TMS)
- 200 number local directory
- Received Calls with Date and Time
- Placed Calls with Date and Time
- Missed Calls with Date and Time

POWER

Profile 42"

- Auto-sensing power supply
- 100-120/200-240 VAC, 60/50Hz, 4.5A max
- Maximum power rating 365W

Profile 52"

- Auto-sensing power supply
- 100-120/200-240 VAC, 60/50Hz, 6A max
- Maximum power rating 526W

Profile 52" Dual

- Auto-sensing power supply
- 100-120/200-240 VAC, 60/50Hz, 10/5A max
- Maximum power rating 870W

OPERATING TEMPERATURE AND HUMIDITY

- 0° C to 35° C (32° F to 95° F) ambient temperature
- 10% to 90% Relative Humidity (RH)

STORAGE AND TRANSPORT TEMPERATURE

- -20° C to 60° C (-4° F to 140° F) at RH 10–90% (non-condensing)

APPROVALS

- Directive 2006/95/EC (Low Voltage Directive) – Standard EN60950-1, 2nd ed
- Directive 2004/108/EC (EMC Directive) – Standard EN55022, Class A – Standard EN55024 – Standard EN61000-3-2/-3-3
- Approved according to UL60950-1 2nd ed and CAN/CSA-C22.2 No. 60950-1-07, 2nd ed
- Complies with FCC15B Class A

DIMENSIONS

Profile 42"

- Height: 63.78" / 162 cm
- Width: 38.58" / 98 cm
- Depth: 6.7" / 17 cm

Profile 52"

- Height: 63.78" / 162 cm
- Width: 47.25" / 120 cm
- Depth: 6.7" / 17 cm

Profile 52" Dual

- Height: 63.5" / 161.3 cm
- Width: 95" / 241.2 cm
- Depth: 6.7" / 17 cm

WEIGHT

Profile 42"

- With foot base: 220.5 lbs / 100 kg
- With wheel base: 200.6 lbs / 91 kg

Profile 52"

- With foot base: 253.5 lbs / 115 kg
- With wheel base: 229.3 lbs / 104 kg

Profile 52" Dual

- With foot base: 515.9 lbs / 234 kg

All specifications are subject to change without notice, system specifics may vary.

All images in these materials are for representational purposes only, actual products may differ.

TANDBERG and Expressway are registered trademarks or trademarks of TANDBERG in the U.S. and other countries.

All other trademarks are property of their respective owners.

MTBF PRODUCT RELIABILITY/MTBF

The predicted reliability is expressed in the expected random Mean Time Between Failures (MTBF) for the electronic components based on the Power On Hours:

Power On Hours (POH) > 69 000 hours

Useful Life Cycle > 6 years

ISO 9001 certificate is available upon request

December 2009

* requires option

** only one LAN/Ethernet interface supported

Technical specifications for Profile 65"

UNIT DELIVERED COMPLETE WITH:

Full HD LCD display, Codec C60, remote control, PrecisionHD 1080p Camera, microphone, Digital Audio Module, integrated speakers and integrated cabling.

MONITOR Available with:

- 65" Full HD LCD, 16:9, 1080x1920 resolution

BASE Available with:

- Floor standing foot plate
- Wall mount on pedestal

BANDWIDTH

- H.323/SIP up to 6 Mbps point-to-point
- H.323/SIP up to 10 Mbps Multisite*

FIREWALL TRAVERSAL

- TANDBERG Expressway™ Technology
- H.460.18, H.460.19 Firewall Traversal
- SIP ICE

VIDEO STANDARDS

- H.261, H.263, H.263+, H.264

VIDEO FEATURES

- Native 16:9 Wide screen
- Advanced Screen Layouts
- Intelligent Video Management
- Local Auto Layout

VIDEO INPUTS (5 INPUTS)

2 X HDMI inputs, supported formats:

- 1920 x 1080@60, 59.94 Hz (1080p60)
- 1920 x 1080@50 Hz (1080p50)
- 1920 x 1080@30, 29.97 Hz (1080p30)
- 1920 x 1080@25 Hz (1080p25)
- 1920 x 1080@24, 23.97 Hz (1080p24)
- 1920 x 1200@50 Hz (WUXGA)
- 1680 x 1050@60 Hz (WSXGA+)
- 1600 x 1200@50, 60 Hz (UXGA)
- 1440 X 900@60 Hz (WXGA+)
- 1400 x 1050@60, 75 Hz
- 1366 x 768@60 Hz
- 1360 x 768@60 Hz
- 1280 x 1024@60, 75, 85 Hz (SXGA)

- 1280 x 960@60, 85 Hz
- 1280 x 800@60 Hz (WXGA)
- 1280 x 768@60, 75, 85 Hz (WXGA)
- 1280 x 720@60, 59.94 Hz (720p60)
- 1280 x 720@50 Hz (720p50)
- 1152 x 864@75 Hz
- 1024 x 768@60, 70, 75, 85 Hz (XGA)
- 848 x 480@60 Hz
- 800 x 600@56, 60, 72, 75, 85 Hz (SVGA)
- 720 x 576@50 Hz (576p50)
- 720 x 480@60, 59.94 Hz (480p60)
- 640 x 480@60, 72, 75, 85 Hz (VGA)

2 x DVI-I inputs, supported formats:

Digital (DVI-D):

- Same as HDMI, ref. above.

Analog RGB (DVI-A):

- 1920 x 1080@60 Hz (1080p60)
- 1920 x 1200@50 Hz (WUXGA)
- 1680 x 1050@60 Hz (WSXGA+)
- 1600 x 1200@60 Hz (UXGA)
- 1440 x 900@60 Hz (WXGA+)
- 1400 x 1050@60, 75 Hz
- 1366 x 768@60 Hz
- 1360 x 768@60 Hz
- 1280 x 1024@60, 75, 85 Hz (SXGA)
- 1280 x 960@60, 85 Hz
- 1280 x 800@60 Hz (WXGA)
- 1280 x 768@60, 75, 85 Hz (WXGA)
- 1280 x 720@60 Hz (720p60)
- 1152 x 864@75 Hz
- 1024 x 768@60, 70, 75, 85 Hz (XGA)
- 848 x 480@60 Hz
- 800 x 600@56, 60, 72, 75, 85 Hz (SVGA)
- 720 x 576@50 Hz
- 720 x 480@60, 59.94 Hz (480p60)
- 640 x 480@60, 72, 75, 85 Hz (VGA)

Analog YPbPr (DVI-A):

- 1920 x 1080@60 Hz (1080p60)
- 1920 x 1080@50 Hz (1080p50)
- 1920 x 1080@30 Hz (1080p30)
- 1920 x 1080@25 Hz (1080p25)
- 1280 x 720@60 Hz (720p60)
- 1280 x 720@50 Hz (720p50)
- 1280 x 720@30 Hz (720p30)

- 720 x 576@50 Hz (576p50)
- 720 x 480@60 Hz (480p60)

Extended Display Identification Data (EDID)

1 X Composite input (BNC connector), supported formats:

- PAL/NTSC

VIDEO OUTPUTS (2 OUTPUTS)

1 X HDMI output, 1 X DVI-I output, supported formats:

- 1920 x 1080@60 Hz (1080p60)
- 1920 x 1200@60Hz (WUXGA)
- 1600 x 1200@60 Hz (UXGA)
- 1366 x 768@60 Hz
- 1360 x 768@60 Hz
- 1280 x 720@60 Hz (720p60)
- 1280 x 1024@60 Hz (SXGA)
- 1280 x 768@60 Hz (WXGA)
- 1024 x 768@60 Hz (XGA)
- 800 x 600@60 Hz (SVGA)
- 640 x 480@60 Hz (VGA)

VESA Monitor Power Management

1 X Composite output (BNC connector), supported formats:

- PAL/NTSC

LIVE VIDEO RESOLUTIONS (ENCODE/DECODE)

- 176 x 144@30 fps (QCIF)
- 352 x 288@30 fps (CIF)
- 512 x 288@30 fps (w288p)
- 576 x 448@30 fps (448p)
- 768 x 448@30 fps (w448p)
- 704 x 576@30 fps (4CIF)
- 1024 x 576@30 fps (w576p)
- 640 x 480@30 fps (VGA)
- 800 x 600@30 fps (SVGA)
- 1024 x 768@30 fps (XGA)
- 1280 x 1024@30 fps (SXGA)
- 1280 x 720@30 fps (720p30)
- 1920 x 1080@30 fps (1080p30)*
- 1280 x 768@30 fps (WXGA)
- 1440 x 900@30 fps (WXGA+)
- 1680 x 1050@30 fps (WSXGA+)
- 1600 x 1200@30 fps (UXGA)
- 512 x 288@60 fps (w288p60)*

- 768 x 448@60 fps (w448p60)*
- 1024 x 576@60 fps (w576p60)*
- 1280 x 720@60 fps (720p60)*

AUDIO STANDARDS

- G.711, G.722, G.722.1, 64 bit & 128 bit MPEG4 AAC-LD, AAC-LD Stereo

AUDIO FEATURES

- CD-Quality 20KHz Mono and Stereo
- Four separate acoustic echo cancellers
- 4-port Audio mixer
- Automatic Gain Control (AGC)
- Automatic Noise Reduction
- Active lip synchronization
- ALD (Assistive Listening Devices) support with acoustic echo cancellation

AUDIO INPUTS (7 INPUTS)

- 4 x microphone, 48V phantom powered, XLR connector each with separate echo cancellers and noise reduction, all microphones can be set for balanced line level
- 2 x RCA/Phono, Line Level: Stereo PC input, configurable to 2 x RCA/Phono, Line Level: Mono auxiliary/DVD input
- 1 x HDMI, digital: Stereo PC/DVD inputs

AUDIO OUTPUTS (3 OUTPUTS)

- 2 x RCA/Phono, line level, stereo main audio, configurable to S/PDIF or 2 x RCA/Phono, line level, mono to recording device
- 1 x HDMI, digital, stereo main audio

DUAL STREAM

- H.239 (H.323) dual stream
- BFCP (SIP) dual stream
- Support for resolutions up to 1080p30 in both main stream and dual stream simultaneously

MULTISITE FEATURES*

- 4-way 720p30 High Definition SIP/H.323 MultiSite
- Full individual audio and video transcoding
- Individual layouts in MultiSite CP (Takes out SelfView)
- H.323/SIP/VoIP in the same conference
- Best Impression (Automatic CP Layouts)
- H.264, Encryption, Dual Stream from any site
- IP Downspeeding
- Dial in/Dial out
- Conference rates up to 10 Mbps

Technical specifications for Profile 65", cont...

PROTOCOLS

- H.323
- SIP

EMBEDDED ENCRYPTION

- H.323/SIP point-to-point
- Standards-based: H.235 v2 & v3 and AES
- Automatic key generation and exchange
- Supported in Dual Stream

IP NETWORK FEATURES

- DNS lookup for service configuration
- Differentiated Services (QoS)
- IP adaptive bandwidth management (including flow control)
- Auto gatekeeper discovery
- Dynamic playout and lip-sync buffering
- H.245 DTMF tones in H.323
- Date and Time support via NTP
- Packet Loss based Downspeeding
- URI Dialing
- TCP/IP
- DHCP
- Direct DNS dialing

SECURITY FEATURES

- Management via HTTPS and SSH
- IP Administration Password
- Menu Administration Password
- Disable IP services
- Network Settings protection

NETWORK INTERFACES **

- 1 x LAN/Ethernet (RJ-45) 10/100/1000 Mbit

OTHER INTERFACES

- USB host for future usage
- USB device for future usage
- GPIO for future usage

PRECISIONHD 1080P CAMERA

- 1/3" CMOS
- 12 x zoom
- +15°/-25° tilt, +/- 90° pan

- 43.5° vertical field of view
- 72° horizontal field of view
- Focus distance 0.3m–infinity
- 1920 x 1080 pixels progressive @ 60fps
- Other formats supported (configurable through Dip-switch):
 - 1920 x 1080@60 Hz (HDMI only)
 - 1920 x 1080@50 Hz (HDMI only)
 - 1920 x 1080@30 Hz
 - 1920 x 1080@25 Hz
 - 1280 x 720@60 Hz
 - 1280 x 720@50 Hz
 - 1280 x 720@30 Hz
 - 1280 x 720@25 Hz
- Automatic or manual focus/brightness/white balance
- Far-end camera control
- Daisy-chain support (Visca protocol camera)
- Dual HDMI and HD-SDI output
- Upside-down mounting with automatic flipping of picture

SYSTEM MANAGEMENT

- Support for the TANDBERG Management Suite
- Total management via embedded SNMP, Telnet, SSH, XML, SOAP
- Remote software upload: via web server, SCP, HTTP, HTTPS
- 1 x RS-232 for local control and diagnostics
- Remote control and on-screen menu system

DIRECTORY SERVICES

- Support for Local directories (My Contacts)
- Corporate Directory
- Unlimited entries using Server directory supporting LDAP and H.350
- Unlimited number for Corporate directory (through TMS)
- 200 number local directory
- Received Calls with Date and Time
- Placed Calls with Date and Time
- Missed Calls with Date and Time

POWER

- Auto-sensing power supply
- 100-120/200-240 VAC, 60/50Hz
- Maximum power rating 800 Watt
- Normal operation 650 Watt

OPERATING TEMPERATURE AND HUMIDITY

- 0° C to 35° C (32° F to 95° F) ambient temperature
- 10% to 90% Relative Humidity (RH)

STORAGE AND TRANSPORT TEMPERATURE

- -20° C to 60° C (-4° F to 140° F) at RH 10–90% (non-condensing)

APPROVALS

- Directive 2006/95/EC (Low Voltage Directive)
 - — Standard EN 60950-1
- Directive 2004/108/EC (EMC Directive)
 - — Standard EN 55022, Class B
 - — Standard EN 55024
 - — Standard EN 61000-3-2/-3-3
- Approved according to UL 60950-1 and CSA 60950-1
- 1-07
- Complies with FCC15B Class B

DIMENSIONS

- Height: 167 cm (65.6 inches)
- Width: 153 cm (60.3 inches)
- Depth: 17 cm (6.8 inches)

WEIGHT

- With foot base: 330 lbs / 150 kg

All specifications are subject to change without notice, system specifics may vary.

All images in these materials are for representational purposes only, actual products may differ.

TANDBERG and Expressway are registered trademarks or trademarks of TANDBERG in the U.S. and other countries.

All other trademarks are property of their respective owners.

MTBF PRODUCT RELIABILITY/MTBF

The predicted reliability is expressed in the expected random Mean Time Between Failures (MTBF) for the electronic components based on the Power On Hours:

Power On Hours (POH) > 69 000 hours

Useful Life Cycle > 6 years

ISO 9001 certificate is available upon request

December 2009

* requires option

** only one LAN/Ethernet interface supported

TANDBERG

U.S. HEADQUARTERS

TANDBERG

1212 Avenue of the Americas

24th Floor

New York, NY 10036

Telephone: +1 212 692 6500

Fax: +1 212 692 6501

Video: +1 212 692 6535

E-mail: tandberg@tandberg.com

EUROPEAN HEADQUARTERS

TANDBERG

Philip Pedersens vei 20

1366 Lysaker

Norway

Telephone: +47 67 125 125

Fax: +47 67 125 234

Video: +47 67 126 126

E-mail: tandberg@tandberg.com

TANDBERG
See: **green** 

Free Manuals Download Website

<http://myh66.com>

<http://usermanuals.us>

<http://www.somanuals.com>

<http://www.4manuals.cc>

<http://www.manual-lib.com>

<http://www.404manual.com>

<http://www.luxmanual.com>

<http://aubethermostatmanual.com>

Golf course search by state

<http://golfingnear.com>

Email search by domain

<http://emailbydomain.com>

Auto manuals search

<http://auto.somanuals.com>

TV manuals search

<http://tv.somanuals.com>