

Tanaka

Parts Catalog

Water Pump

Model: QCP-121

All Units Prior To Serial Number K 171825

FIG. 1 ENGINE

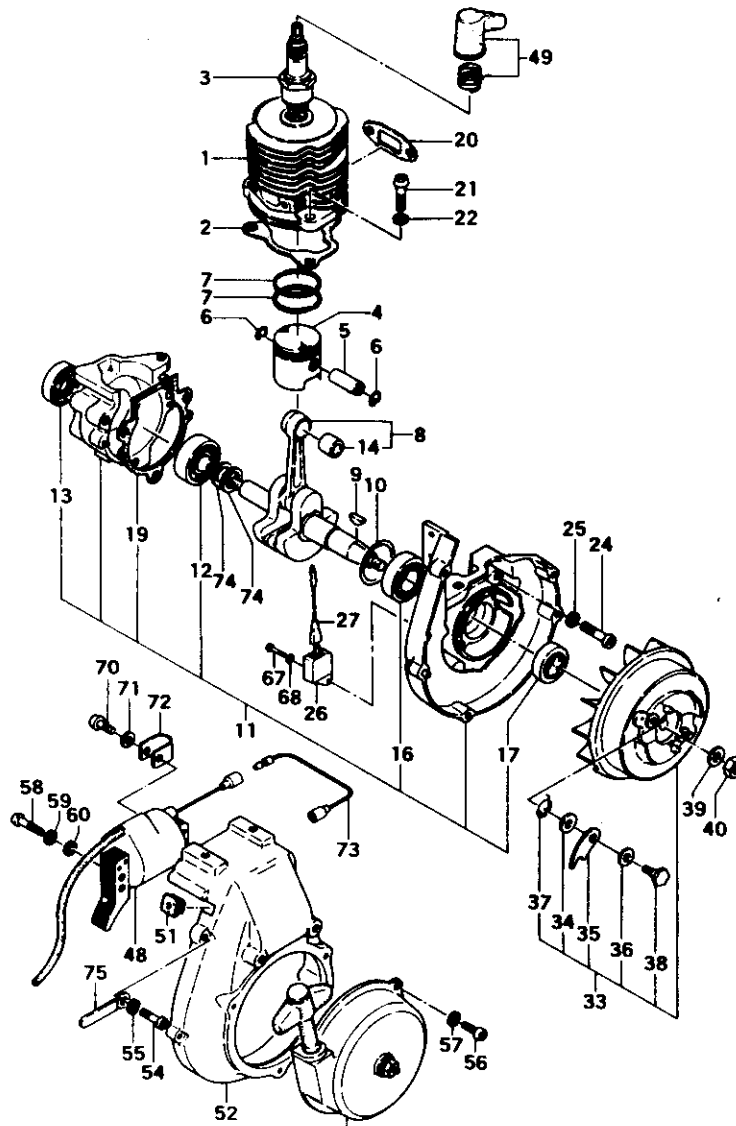

SEE FIG. 4

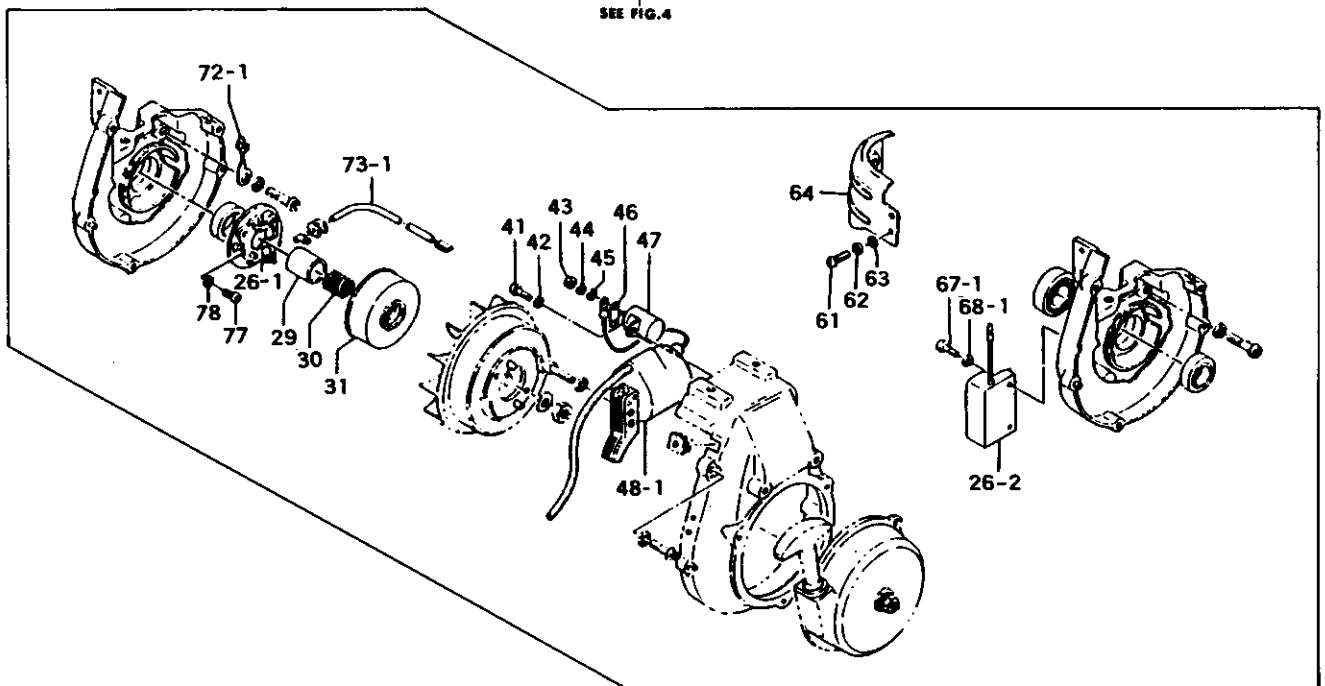

REF. NBR	PART NBR	PART NAME	QTY	SERIAL NBR	REMARKS
1-001	002-00500-804	CYLINDER COMP.	1		
1-002	017-00501-202	CYLINDER GASKET	1		
1-003	018-00502-200	SPARK PLUG BM6A	1		
1-004	031-00500-200	PISTON	1		
1-005	037-00000-200	PISTON PIN 9X24	1		
1-006	039-00000-201	PISTON PIN CIRCLIP	2		
1-007	041-00000-200	PISTON RING	2	I -H114700	
1-007	041-00000-210	PISTON RING	2	H114701-	
1-008	046-00532-802	CRANK SHAFT COMP.	1	-D018779	
1-008	046-00573-800	CRANK SHAFT COMP.	1	M D018780-	
1-009	068-02000-200	WOOD-RUFF KEY 3X13X5	1		
1-010	070-02401-201	CRANK SHAFT WASHER 15.2X22	1		
1-011	072-00531-900	CRANK CASE ASS'Y	1	R -D018779	
1-011	072-00557-900	CRANK CASE ASS'Y	1	D018780-	
1-012	999-61620-100	BALL BEARING #6201. 32MM/OD	1		
1-013	999-66122-821	OIL SEAL 12287	1		
1-014	038-00000-200	PISTON PIN BUSHING	1	M	NLA
1-016	999-61600-200	BALL BEARING #6002. 32MM/OD	1		
1-017	999-66152-500	OIL SEAL 15257	1		
1-019	090-00501-202	CRANK CASE GASKET	1		
1-020	737-00531-201	MUFFLER GASKET	1		
1-021	990-11060-201	SCREW 6X20	3	M	
1-021	990-11060-181	SCREW 6X18	3		
1-022	992-10060-012	S.WASHER 6	3		
1-024	990-11060-221	SCREW 6X22	3		
1-025	992-10060-012	S.WASHER 6	3		
1-026.1	159-20702-900	CONTACT BREAKER ASS'Y	1	-D018779	
1-026.2	159-21401-871	IGNITOR COMP. TTI-1E	1	N -F020571	
1-026	159-21401-872	IGNITOR COMP. TTI-1F	1	N F020572-	
1-027	173-01620-800	IGNITOR LEAD WIRE COMP., R110M	1	N F020572-	
1-029	246-20701-201	MAGNETO CAM	1	D D018780-	
1-030	247-01000-201	CAM SUPPORT SPRING	1	D D018780-	
1-031	191-00501-201	CONTACT POINT COVER	1	D D018780-	
1-033	155-21708-900	MAGNETO ROTOR ASS'Y	1		
1-034	992-01050-011	WASHER 5	2		
1-035	788-00601-203	STARTER PAWL	2		
1-036	822-00601-200	STARTER PAWL SHIM 0.6T	2		
1-037	790-00601-203	STARTER PAWL SPRING	2		
1-038	793-10200-200	STEP BOLT	2	R -B058855	
1-038	793-10200-201	STEP BOLT	2	-J075260	
1-038	793-10200-202	STEP BOLT	2	P J075261-	
1-039	065-00000-200	FLYWHEEL WASHER	1		
1-040	066-00000-200	FLYWHEEL NUT 12	1		
1-041	990-11040-081	SCREW 4X8	1	D D018780-	
1-042	992-10040-012	S.WASHER 4	1	D D018780-	
1-043	991-01030-011	HEX. NUT 3	1	D D018780-	
1-044	992-10030-012	S.WASHER 3	1	D D018780-	
1-045	992-01030-011	WASHER 3	1	D D018780-	
1-046	205-00501-200	TERMINAL TAB	1	D D018780-	
1-047	177-20701-801	CONDENSER COMP.	1	D D018780-	
1-048.1	167-20710-801	IGNITION COIL COMP.	1	-D018779	
1-048	167-20741-800	IGNITION COIL COMP.	1	M D018780-	
1-049	157-04000-900	SPARK PLUG CAP ASS'Y	1		
1-051	202-10200-201	GROMMET	1		
1-052	112-00532-205	FAN CASE,TAS ORANGE	1	I -C038384	
1-052	112-00563-200	FAN CASE,LIGHT ORANGE	1	C038385-	
1-054	990-11050-201	SCREW 5X20	3		
1-055	992-10050-012	S.WASHER 5	3		
1-056	990-11040-101	SCREW 4X10	3		
1-057	992-10040-012	S.WASHER 4	3		
1-058	990-11050-201	SCREW 5X20	2	M	
1-058	990-11050-401	SCREW 5X40	2		
1-059	992-10050-012	S.WASHER 5	2		

- To be cont'd -

REF. NBR	PART NBR	PART NAME	QTY	SERIAL NBR	REMARKS
1-060	992-00050-011	SMALL WASHER 5	2		
1-061	990-11040-081	SCREW 4X8	3 D	C064123-	
1-062	992-10040-012	S. WASHER 4	3 D	C064123-	
1-063	992-01040-011	WASHER 4	3 D	C064123-	
1-064	132-00502-201	FLASH PAN	1 D	C064123-	
1-067.1	990-11040-161	SCREW 4X16	2	-F020571	
1-067	990-11040-081	SCREW 4X8	1 N	F020572-	
1-068.1	992-10040-012	S. WASHER 4	2	-F020571	
1-068	992-10040-012	S. WASHER 4	1	-F020572	
1-070	990-11040-101	SCREW 4X10	1 N		
1-070	990-11040-081	SCREW 4X8	1 N	D018780-	
1-071	992-01040-011	WASHER 4	1 N		
1-071	992-00040-011	SMALL WASHER 4	1 N	D018780-	
1-072.1	198-00501-200	CORD CLAMP	1	-D018779	
1-072	198-00701-200	CORD CLAMP	1 N		
1-072	198-00701-201	CORD CLAMP	1 N	D018780-	
1-073.1	173-20702-804	PRIMARY CORD COMP., SPECIAL	1	-D018779	
1-073	178-00610-801	STOP CORD COMP.	1 N	D018780-	
1-074	070-00601-201	CRANK SHAFT WASHER 12.2X18	2		
1-075	198-01046-900	CORD CLAMP ASS'Y	1 I	-F186220	
1-075	198-05015-800	CORD CLAMP COMP.	1	F186221-	
1-077	990-11040-081	SCREW 4X8	2 D	D018780-	
1-078	992-01040-011	WASHER 4	2 D	D018780-	

FIG.2 CARBURETOR

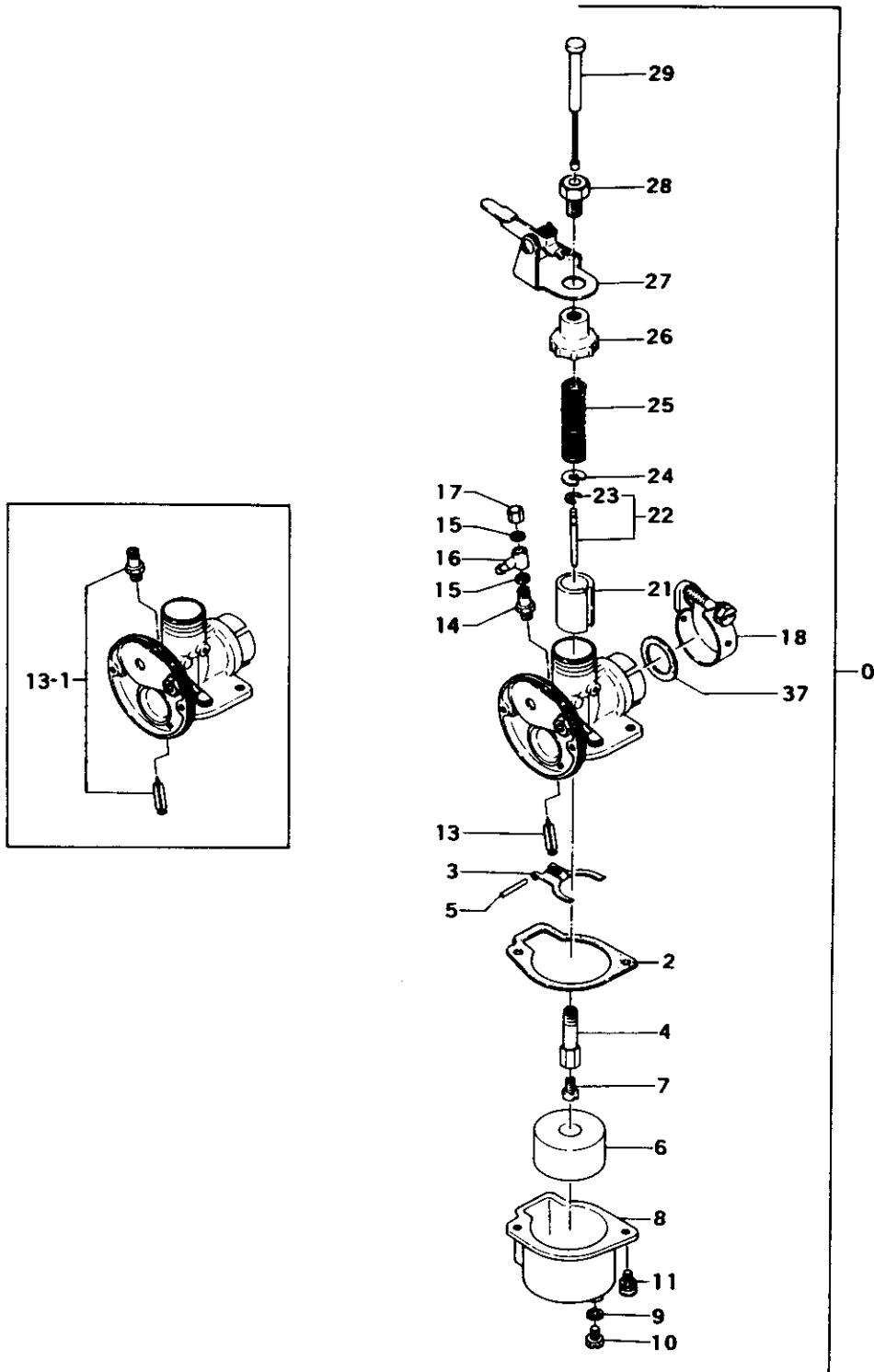

REF. NBR	PART NBR	PART NAME	QTY	SERIAL NBR	REMARKS
2-000	455-20428-901	CARBURETOR ASS'Y	1	I -D019779	
2-000	455-20440-901	CARBURETOR ASS'Y	1	I -D041399	
2-000	455-20440-902	CARBURETOR ASS'Y	1	M	
2-000	455-20441-900	CARBURETOR ASS'Y	1	D041400-	
2-002	607-20110-200	FLOAT CHAMBER GASKET	1		
2-003	628-20400-200	FLOAT ARM	1		
2-004	598-20426-200	NEEDLE JET #85	1	M	
2-004	598-2001T-800	NEEDLE JET 2080	1		
2-005	605-20400-200	FLOAT ARM PIN	1	M	
2-005	605-20202-200	FLOAT ARM PIN	1		
2-006	604-20400-200	FLOAT	1	M	
2-006	604-20110-200	FLOAT	1		
2-007	599-20426-054	MAIN JET #54	1	M	
2-007	599-2001T-540	MAIN JET #54	1		
2-008	606-20426-200	FLOAT CHAMBER	1		
2-009	629-20400-200	DRAIN PLUG GASKET	1		
2-010	627-20400-200	DRAIN PLUG	1		
2-011	990-11040-100	SCREW 4X10	2	M	
2-011	994-14040-120	SCREW 4X12S	2		
2-013, 1	603-20400-900	NEEDLE VALVE ASS'Y	1	M	
2-013	603-20400-200	NEEDLE VALVE	1		
2-014	602-20200-200	VALVE SEAT	1		
2-015	500-20426-200	FUEL INLET GASKET	2		
2-016	499-20426-200	FUEL INLET	1	M	
2-016	499-20200-200	FUEL INLET	1		
2-017	543-20426-200	FUEL INLET CAP NUT	1	M	
2-017	543-20200-200	FUEL INLET CAP NUT	1		
2-018	561-20426-900	BODY BAND ASS'Y	1	M	
2-018	561-20436-900	BODY BAND ASS'Y	1		
2-021	591-20426-200	THROTTLE VALVE	1	M	
2-021	591-2001T-200	THROTTLE VALVE 0.5X1.5	1		
2-022	592-20426-900	JET NEEDLE ASS'Y	1	M	
2-022	592-2008T-920	JET NEEDLE ASS'Y #073	1		
2-023	593-20400-200	JET NEEDLE CLIP	1		
2-024	619-20400-200	THROTTLE SPRING RECEIVE	1	M	
2-024	619-20110-200	THROTTLE SPRING RECEIVE	1		
2-025	594-20400-200	THROTTLE VALVE SPRING	1	M	
2-025	594-20436-200	THROTTLE VALVE SPRING	1		
2-026	595-20426-200	BODY CAP	1		
2-027	500-00532-900	LINK MOTION ARM ASS'Y	1		
2-028	504-00532-200	LINK MOTION NUT	1	M	
2-028	504-20426-200	LINK MOTION NUT	1		
2-029	495-20426-800	LINK MOTION CABLE COMP.	1		
2-037	571-20400-200	FLANGE GASKET	1		

FIG.3 AIR CLEANER & MUFFLER

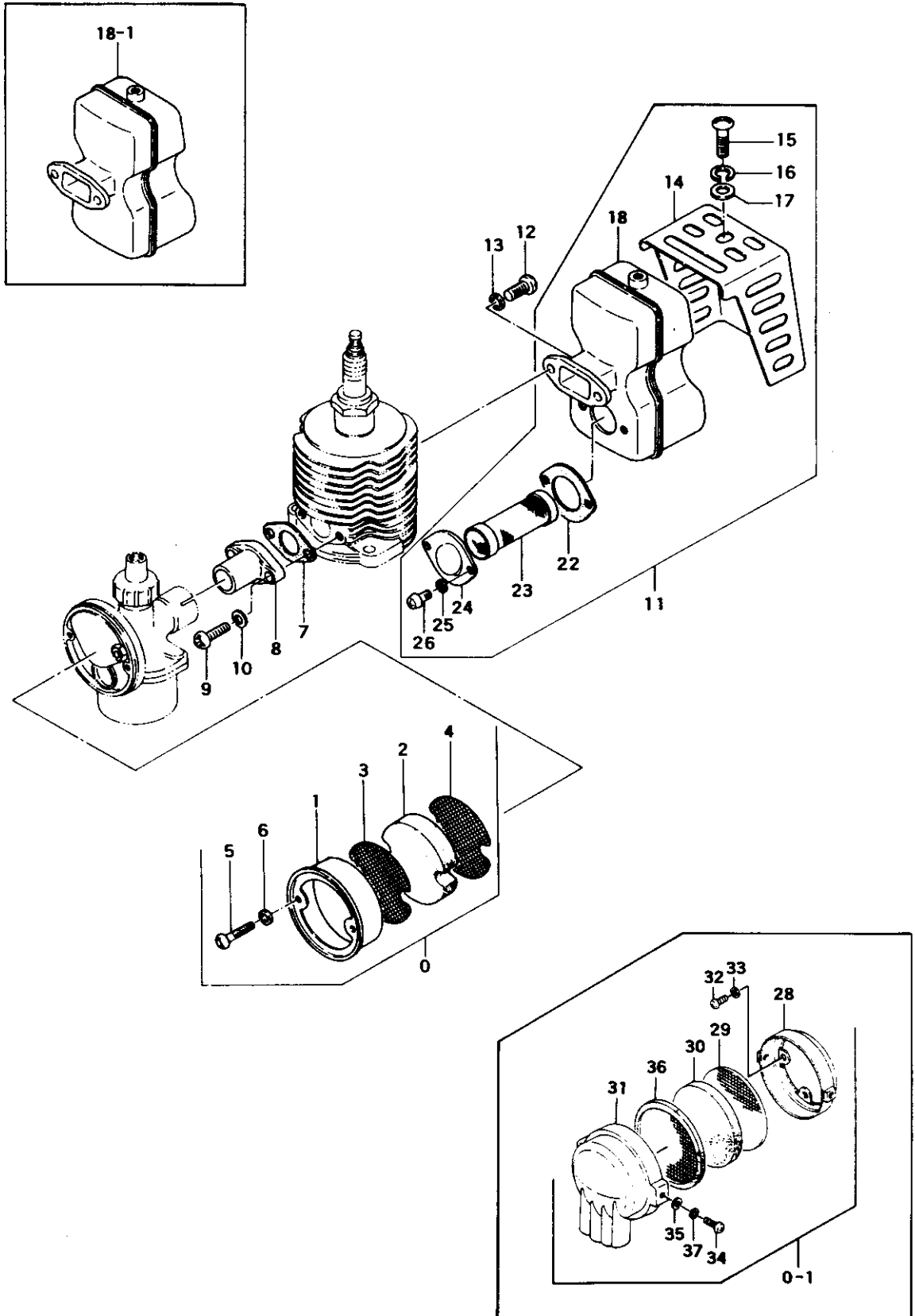

REF. NBR	PART NBR	PART NAME	QTY	SERIAL NBR	REMARKS
3-000.1	410-00700-911	CLEANER ASS'Y	1	-D118690	
3-000	410-00440-900	AIR CLEANER ASS'Y	1	N D118691-	
3-001	424-00532-200	AIR CLEANER COVER	1	N D118691-	
3-002	421-00532-200	CLEANER ELEMENT	1	N D118691-	
3-003	425-00532-200	CLEANER HOLDER A	1	N D118691-	
3-004	426-00532-200	CLEANER HOLDER B	1	N D118691-	
3-005	990-11040-161	SCREW 4X16	2	N	
3-005	990-11040-160	SCREW 4X16	2	N D118691-	
3-006	992-10040-012	S. WASHER 4	2	N D118691-	
3-007	403-00001-200	INLET MANIFOLD GASKET	1		
3-008	393-00005-202	INLET MANIFOLD	1	-A176334	
3-008	393-00005-203	INLET MANIFOLD	1	P A176335-	
3-009	990-11050-161	SCREW 5X16	2		
3-010	992-10050-012	S. WASHER 5	2		
3-011	705-00573-900	MUFFLER ASS'Y	1		
3-012	990-11050-141	SCREW 5X14	2		
3-013	992-10050-012	S. WASHER 5	2		
3-014	738-00501-202	MUFFLER PROTECTOR	1	N C091881-	
3-015	990-11060-081	SCREW 6X8	2	N C091881-	
3-016	992-10060-012	S. WASHER 6	2	N C091881-	
3-017	992-01060-011	WASHER 6	2	N C091881-	
3-018.1	706-00580-800	MUFFLER COMP.	1	R -C091880	
3-018.1	706-00550-800	MUFFLER COMP.	1	-D019080	
3-018	706-00573-800	MUFFLER COMP.	1	N D019081-	
3-022	751-00573-200	MUFFLER GASKET	1	N D019081-	
3-023	732-00573-800	SPARK ARRESTER COMP.	1	N D019081-	
3-024	722-00573-200	PARTITION PLATE	1	N D019081-	
3-025	992-10040-012	S. WASHER 4	2	N D019081-	
3-026	990-11040-101	SCREW 4X10	2	N D019081-	
3-028	423-00700-800	CLEANER BODY COMP.	1	D D118691-	
3-029	426-00700-210	CLEANER HOLDER	1	D D118691-	
3-030	446-00700-220	CLEANER ELEMENT	1	D D118691-	
3-031	424-00700-212	AIR CLEANER COVER	1	D D118691-	
3-032	990-11040-101	SCREW 4X10	2	D D118691-	
3-033	992-10040-012	S. WASHER 4	2	D D118691-	
3-034	990-11040-101	SCREW 4X10	2	D D118691-	
3-035	992-01040-011	WASHER 4	2	D D118691-	
3-036	425-00700-200	CLEANER HOLDER A	1	D D118691-	
3-037	992-10040-012	S. WASHER 4	2	D D118691-	

FIG.4 RECOIL STARTER

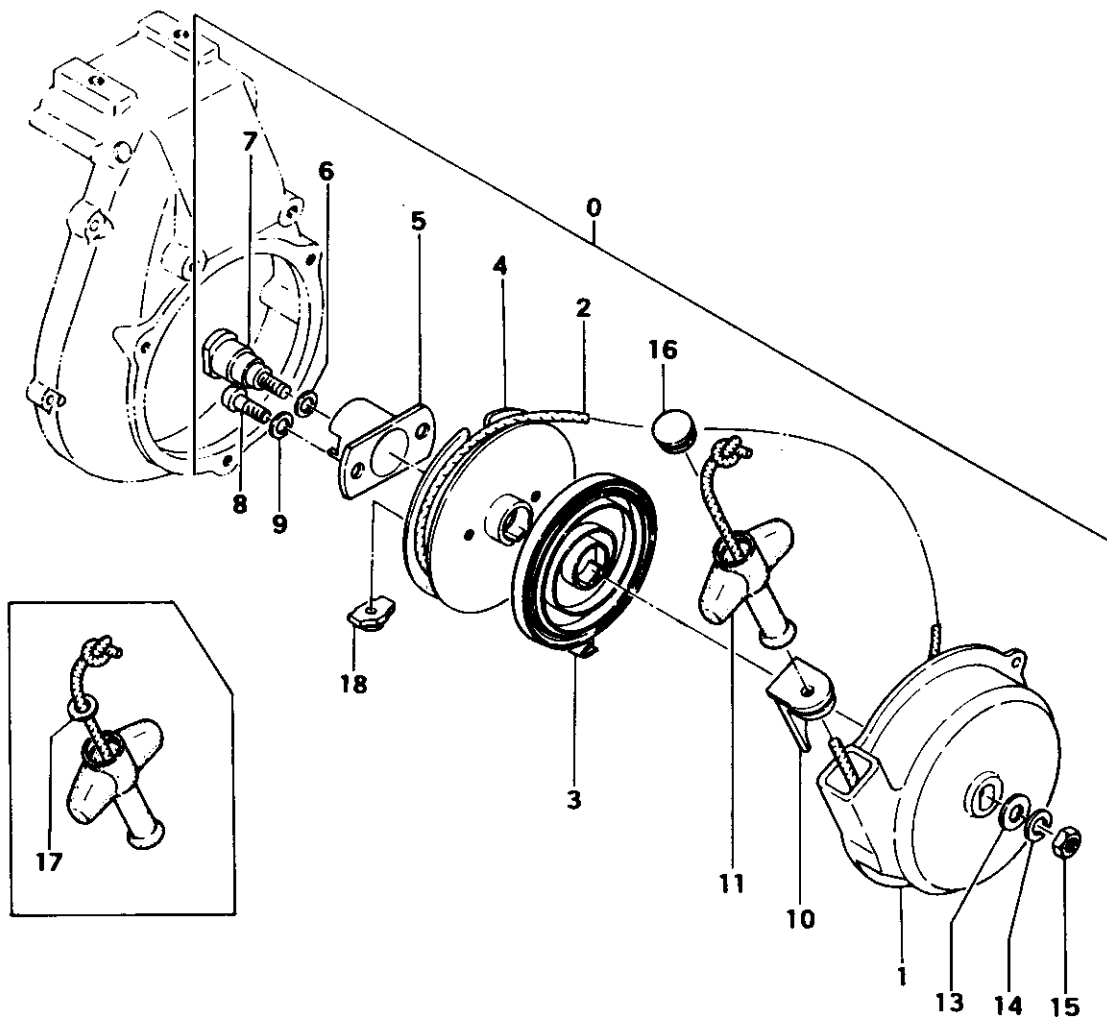

REF. NBR	PART NBR	PART NAME	QTY	SERIAL NBR	REMARKS
4-000	756-00532-901	RECOIL STARTER ASS'Y	1		
4-001	772-00532-201	RECOIL STARTER BODY	1		
4-002	783-01006-201	STARTER ROPE	1		
4-003	779-01006-201	RECOIL SPRING	1		
4-004	774-01006-204	STARTER ROPE REEL	1		
4-005	773-01006-206	PULLEY SHAFT/OUTER	1		
4-006	814-00500-200	STARTER PULLEY SHIM	1		
4-007	776-01006-207	PULLEY SHAFT	1		
4-008	990-11050-101	SCREW 5X10	2		
4-009	992-10050-012	S. WASHER 5	2	I -H180430	
4-009	992-00050-011	SMALL WASHER 5	2	H180431-	
4-010	780-01006-201	ROPE GUIDE	1		
4-011	785-10207-201	STARTER HANDLE	1		
4-013	992-01060-011	WASHER 6	1		
4-014	992-10080-012	S. WASHER 6	1		
4-015	991-01060-011	NUT 6	1		
4-016	833-10207-200	STARTER HANDLE CAP	1		
4-017	992-01040-011	WASHER 4	1	M	
4-017	992-00040-011	SMALL WASHER 4	1	D J075261-	
4-018	782-00546-200	ROPE RECEIVE	1		

FIG.5 TANK, CARRYING HANDLE & BASE

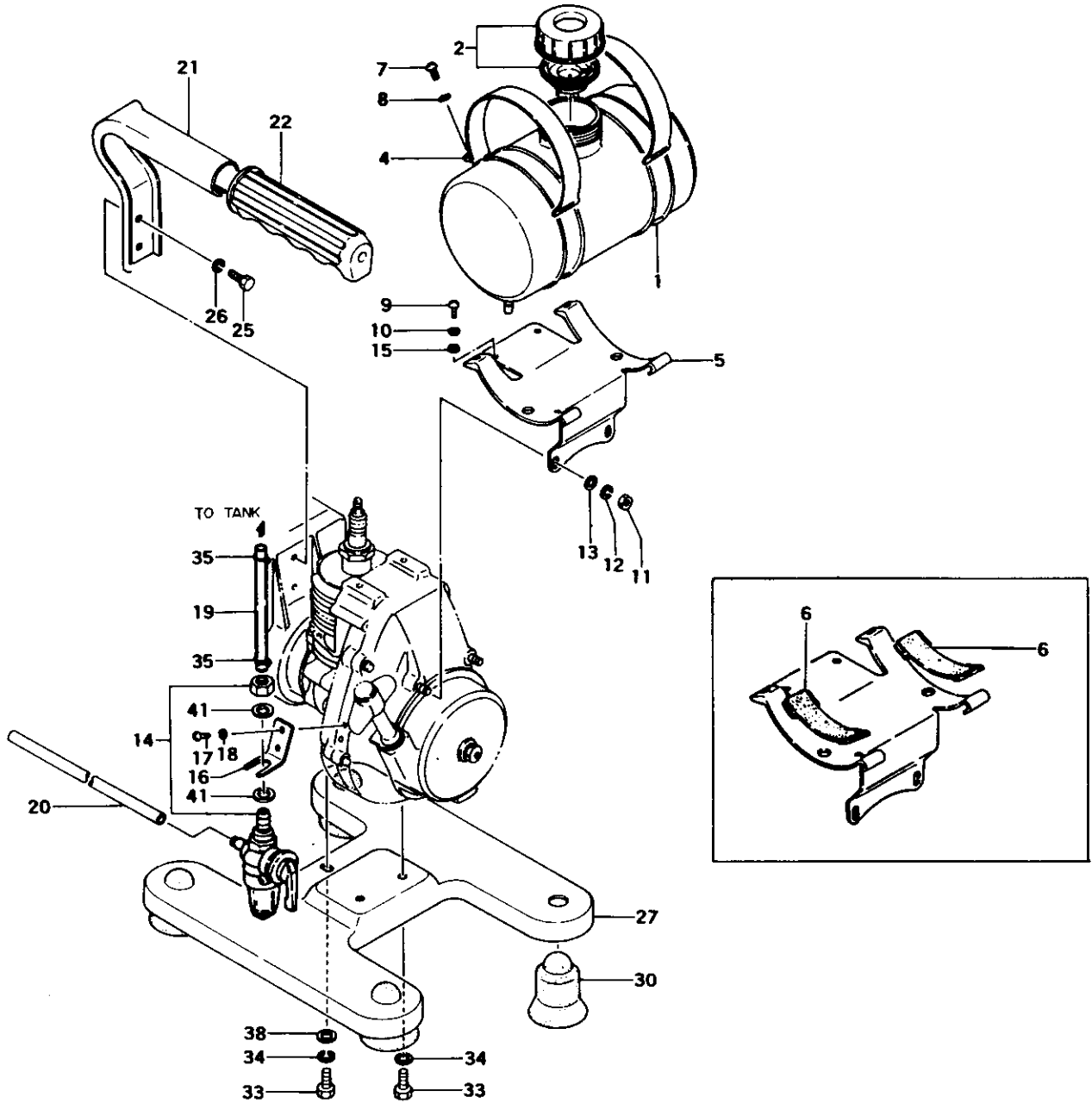

REF. NBR	PART NBR	PART NAME	QTY	SERIAL NBR	REMARKS
5-001	591-00573-200	TANK.50:1	1		
5-002	595-00532-900	TANK CAP ASS'Y	1		
5-004	648-00532-203	FUEL TANK BAND	2		
5-005	607-00532-804	FUEL TANK BRACKET COMP.	1		
5-006	655-00532-200	FUEL TANK CUSHION RUBBER	2	D C091881-	
5-007	990-11050-121	SCREW 5X12	2	M	
5-007	990-11050-201	SCREW 5X20	2		
5-008	992-01050-011	WASHER 5	2	M	
5-008	992-10050-012	S.WASHER 5	2		
5-009	990-11050-121	SCREW 5X12	2		
5-010	992-10050-012	S.WASHER 5	2		
5-011	991-01050-011	HEX. NUT 5	2		
5-012	992-10050-012	S.WASHER 5	2		
5-013	992-01050-011	WASHER 5	2		
5-014	592-00002-900	PET-COCK ASS'Y	1	P -C040394	
5-014	592-00002-901	PET-COCK ASS'Y	1	P C040395-	
5-015	992-01050-011	WASHER 5	2		
5-016	662-00532-201	PET-COCK BRACKET	1		
5-017	990-11050-101	SCREW 5X10	2		
5-018	992-10050-012	S.WASHER 5	2		
5-019	700-05008-095	FUEL PIPE A	1		
5-020	700-05008-140	FUEL PIPE B	1		
5-021	090-31200-802	HANDLE COMP.	1		
5-022	266-30600-201	HANDLE GRIP	1		
5-025	990-21060-121	BOLT 6X12	2		
5-026	992-10060-012	S.WASHER 6	2		
5-027	080-31200-201	BASE	1	P -C091880	
5-027	080-31223-200	ENGINE BED	1	P C091881-	
5-030	312-31700-201	CUSHION RUBBER	4		
5-033	990-21060-121	BOLT 6X12	3		
5-034	992-10060-012	S.WASHER 6	3		
5-035	680-01004-200	CLIP 8	2		
5-038	992-01060-011	WASHER 6	1		
5-041	992-00100-011	SMALL WASHER 10	2		

FIG.6 PUMP

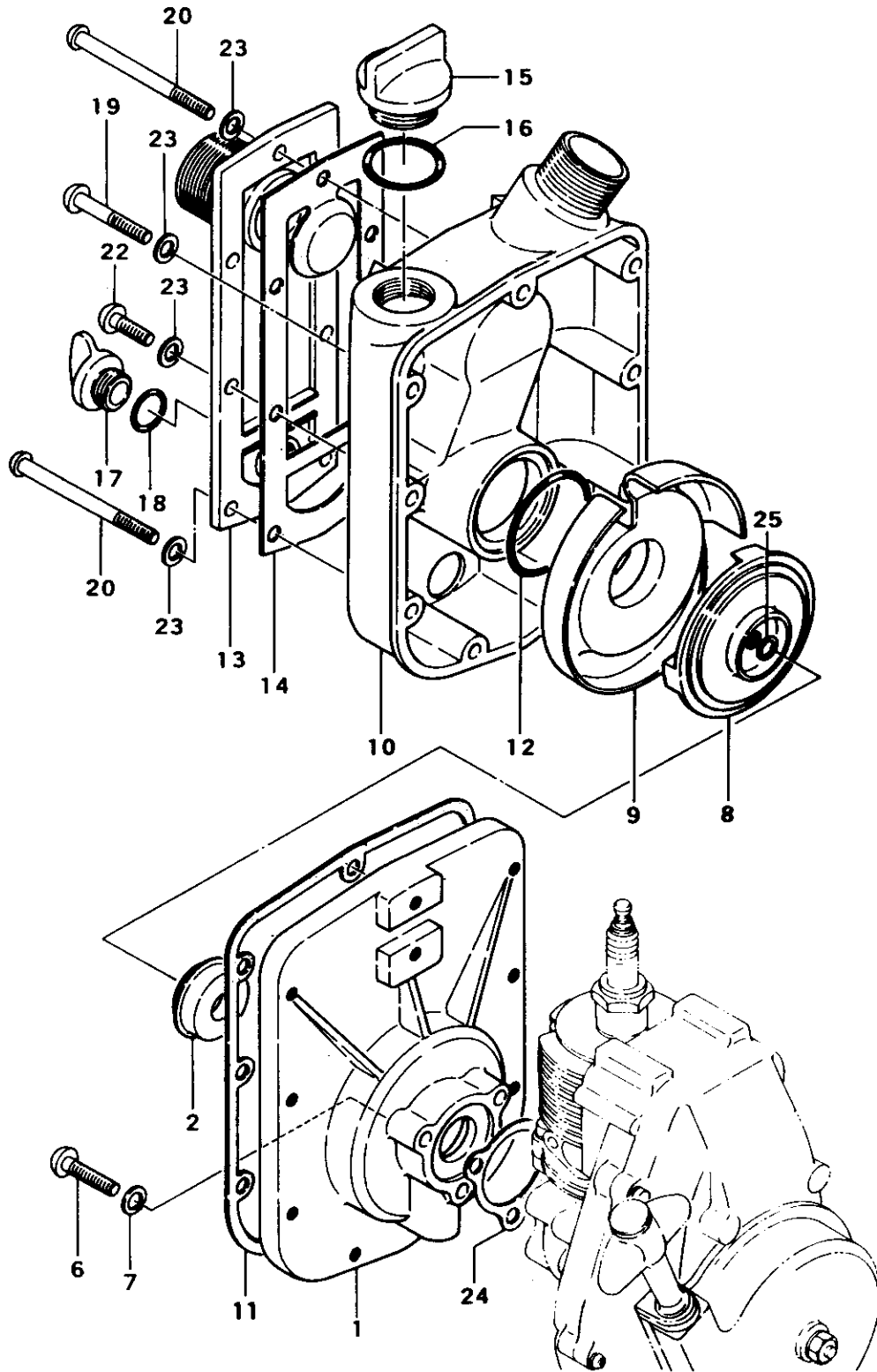

REF. NBR	PART NBR	PART NAME	QTY	SERIAL NBR	REMARKS
6-001	300-31200-211	COUPLING PLATE	1		
6-002	160-31200-915	MECHANICAL SEAL ASS'Y	1		
6-006	990-11060-281	SCREW 6X28	3		
6-007	992-01060-011	WASHER 6	3	M	
6-007	992-10060-012	S.WASHER 6	3		
6-008	031-31200-200	IMPELLER	1		
6-009	310-31200-200	VOLUTE CHAMBER	1		
6-010	330-31200-200	CASING	1		
6-011	331-31200-202	CASING COVER GASKET	1		
6-012	999-67035-010	O-RING G-35	1		
6-013	320-31200-812	SUCTION PLATE COMP.	1		
6-014	350-31200-800	SUCTION PLATE GASKET	1		
6-015	360-31200-210	PRIMING PLUG	1		
6-016	999-67025-500	O-RING P-25.5	1		
6-017	021-31200-200	DRAIN PLUG	1		
6-018	999-67015-000	O-RING P-15	1		
6-019	990-11060-421	SCREW 6X42	6		
6-020	990-11060-601	SCREW 6X60	3		
6-022	990-11060-161	SCREW 6X16	4	M	
6-022	990-11060-181	SCREW 6X18	4		
6-023	992-01060-011	WASHER 6	13	M	
6-023	992-10060-012	S.WASHER 6	13		
6-024	303-00200-200	GEAR CASE GASKET A	1		
6-025	034-31200-230	IMPELLER SHAFT SHIM 0.2	V		
6-025	034-31200-240	IMPELLER SHAFT SHIM 0.3	V		
6-025	034-31200-250	IMPELLER SHAFT SHIM 0.5	V		
6-025	034-31200-270	IMPELLER SHAFT SHIM 1.0	V		

FIG.7 TOOLS & OPTIONAL PARTS

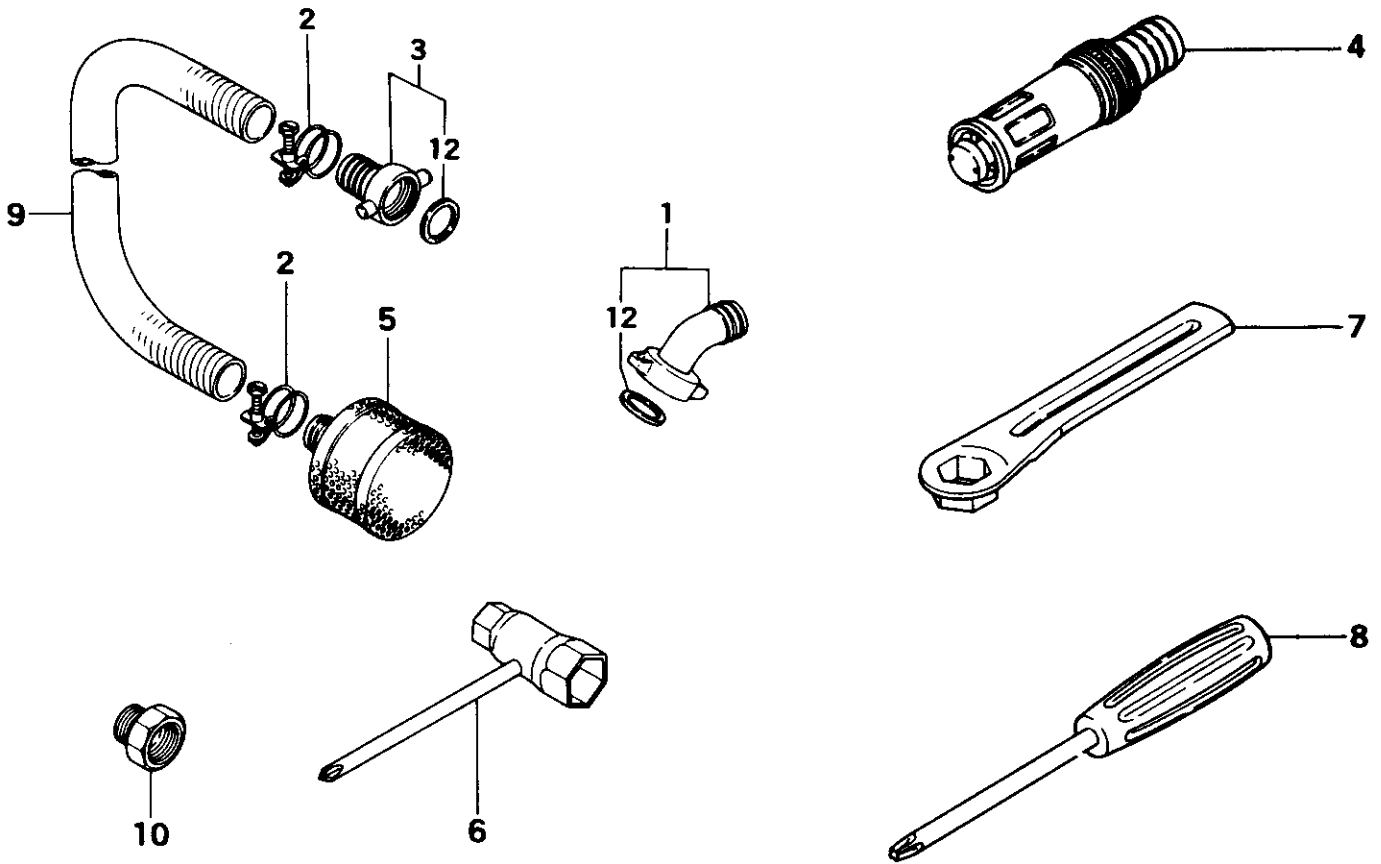

REF. NBR	PART NBR	PART NAME	QTY	SERIAL NBR	REMARKS
7-001	050-31215-900	WATER COUPLING ASS'Y	1		
7-002	132-31200-210	WIRE BAND 32	4	-B005855	
7-002	132-31223-200	WIRE BAND 33	4	P B005856-	
7-003	050-31200-901	WATER COUPLING ASS'Y	1		
7-004	170-31200-802	ADJUSTABLE NOZZLE	1	D C223296-	
7-005	100-31200-800	STRAINER COMP.	1		
7-006	036-29331-501	COMBI. BOX SPANNER 10X19 ,PLUS	1	N H114701-	
7-007	851-20000-201	SPARK PLUG BOX SPANNER	1	D H114701-	
7-008	862-20000-200	PLUS DRIVER 4	1	D H114701-	
7-009	180-31200-200	SUCTION HOSE	1	N C223296-	
7-010	022-31221-200	NIPPLE 3/4-1	1	R -C223295	
7-010	022-31221-210	COUPLING 17/16"	1	C223296-	
7-012	054-31200-202	WATER COUPLING GASKET	2		

FIG.8 MARKS

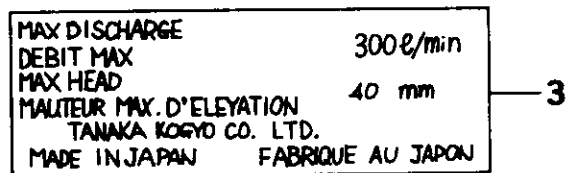
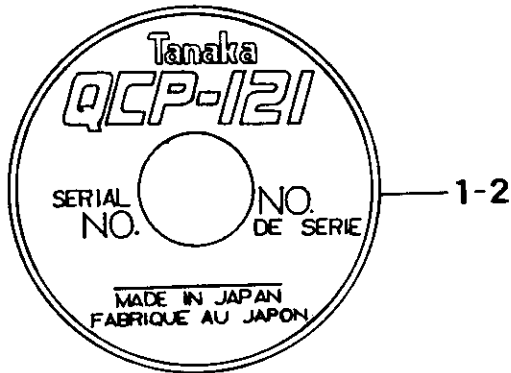
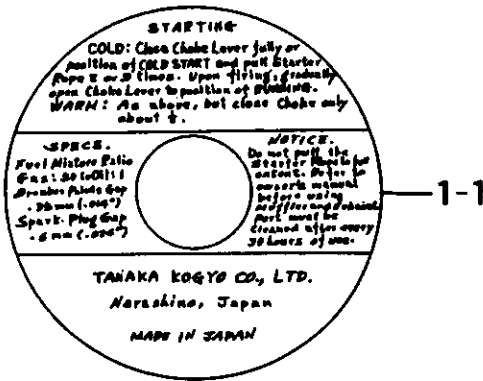

REF. NBR	PART NBR	PART NAME	QTY	SERIAL NBR	REMARKS
8-001.1	913-00501-200	STARTER MARK QEG	1 R	-G248620	
8-001.2	140-31221-211	NAME PLATE	1	-J075260	
8-001	950-31221-200	PROFORCE MARK A	1 M	J075261-	
8-002	908-04021-200	CHOKE MARK	1		
8-003	892-31221-200	OUT PUT MARK	1		
8-004	906-31221-200	NAME PLATE	1 N	J075261-	

Free Manuals Download Website

<http://myh66.com>

<http://usermanuals.us>

<http://www.somanuals.com>

<http://www.4manuals.cc>

<http://www.manual-lib.com>

<http://www.404manual.com>

<http://www.luxmanual.com>

<http://aubethermostatmanual.com>

Golf course search by state

<http://golfingnear.com>

Email search by domain

<http://emailbydomain.com>

Auto manuals search

<http://auto.somanuals.com>

TV manuals search

<http://tv.somanuals.com>