

Safety Instruction & Operator's Manual for

# SNAPPER®

## Model BPB4150M BLOWERS



*Thank you for buying a Snapper Product! Before operating your blower, read this manual carefully and pay particular attention to the Important Safety Instructions on page two. Remember that blowers and all power equipment can be dangerous if used improperly and keep in mind that safety requires careful use in accordance with the instructions and....common sense!*

**SNAPPER POWER EQUIPMENT**

McDonough, GA • 30253



(REVISION 4, 8/90)

**MANUAL # 1-5306**



# IMPORTANT SAFETY INSTRUCTIONS



**WARNING:** Failure to comply with the following instructions may result in serious injury to the operator or other persons. The owner of the blower must understand these instructions and, furthermore, must allow only persons who understand these instructions to operate the unit. Each person operating the blower must be of sound mind and body and must not be under the influence of any substance which might impair vision, dexterity, or judgement. If you have any questions pertaining to your blower which your dealer cannot answer to your satisfaction, call or write the Customer Service Department at SNAPPER POWER EQUIPMENT, McDonough, Georgia, 30253. (Phone 404-957-9141).

## TRAINING

1. Read this Manual carefully. Be thoroughly familiar with the controls and proper use of the equipment.
2. DO NOT allow children in yard when blower is operated.
3. DO NOT allow pre-teenager children to operate blower.
4. Allow only responsible teenagers with mature judgement to operate blower and only under close supervision.
5. Keep the area clear of all persons, particularly small children, and pets.

## PREPARATION

1. DO NOT operate blower without ear plugs, safety glasses or goggles and dust mask when appropriate. Warning: Any operator having long hair MUST contain hair so that it is held UP and AWAY from blower inlet cover (grill) because serious injury could result from hair being sucked into impeller during operation!
2. Thoroughly inspect the area where the blower is to be used and remove all stones, sticks, wire, bones and other objects that could cause injury if thrown at high speeds.
3. Do not operate blower when barefoot or wearing open sandals. Always wear substantial footwear and long pants.
4. Never operate blower without proper guards, shields or other safety protective devices in place and properly connected. Inspect to determine that these safety devices are installed properly, are in good repair, and operate properly. If the condition or operation of these devices are questionable, they must be repaired or replaced before using the blower.
5. Fill gasoline tank before starting engine. Mix in an approved gasoline container. Do not smoke near open gasoline container. Do not fill gasoline tank indoors or when engine is running. Wipe off any spilled gasoline before starting engine. Move away from fueling site before starting engine. Do not run engine indoors. Do not refuel while strapped on operators back.

6. Use blower only in daylight or in good artificial light.

7. Operate only where firm footing is assured. DO NOT operate from a ladder or any other place where use of hands would ordinarily be necessary to prevent falls.

## OPERATION

1. Do not put hands near rotating parts while engine is running.
2. Stop or idle engine when crossing gravel drives, walks, or roads, and under any conditions where thrown objects might be a hazard.
3. Stop engine before leaving unit.
4. Before cleaning, repairing or inspecting, make certain engine has stopped and is cooled. Disconnect and secure spark plug wire away from plug to prevent accidental starting.
5. Always wear harness to help prevent loss of control.
6. Do not operate with long hair or scarfs.
7. Be careful to avoid contacting hot engine parts against trees, brush or other flammable items.

## MAINTENANCE AND STORAGE

1. Keep all nuts, bolts, and screws tight to be sure unit is in safe operating condition.
2. Never store unit with gasoline in the tank inside of a building where fumes may reach an open flame or spark. Allow engine to cool before storing in any enclosure.
3. To reduce fire hazard, keep unit free of grass, leaves or excessive grease.
4. Have your blower inspected and serviced each year by an authorized Snapper dealer. Determine if any additional devices are available which might upgrade the safety of your unit.
5. Use only factory specified Snapper attachments, accessories and fasteners.

# OPERATING INSTRUCTIONS

## PRE-MIX FUEL (32 to 1 RATIO)

For proper lubrication, the engine must operate on an exact mixture of gasoline and 2 cycle air-cooled engine oil. Use a 32 to 1 mixture. Use a good quality regular grade leaded or unleaded gasoline and SNAPPER special formulated 2-cycle engine oil. Do not use the special 50:1 ratio oils. The 32 to 1 ratio equals 4 ounces of oil to each gallon (U.S. Standard) of gasoline, (or 16 oz. to 4 gallons gasoline). Refer to the following chart for correct 32 to 1 ratio mixtures:

Pre-Mix the fuel in an approved container while observing all safety precautions relating to handling of fuel. Add some gasoline to the container first then the oil. Close the container and shake vigorously to thoroughly mix the fuel; open the container and add the remaining amount of gasoline to correct the ratio. Shake the container to mix the fuel each time before filling the blower fuel tank. **DO NOT** add fuel to unit while hot...allow engine to cool.

32:1 RATIO - U.S. STANDARD FLUID MEASUREMENTS

GALLONS GASOLINE*	1	2	3	4	5
OUNCES 2-CYCLE OIL	4	8	12	16	20

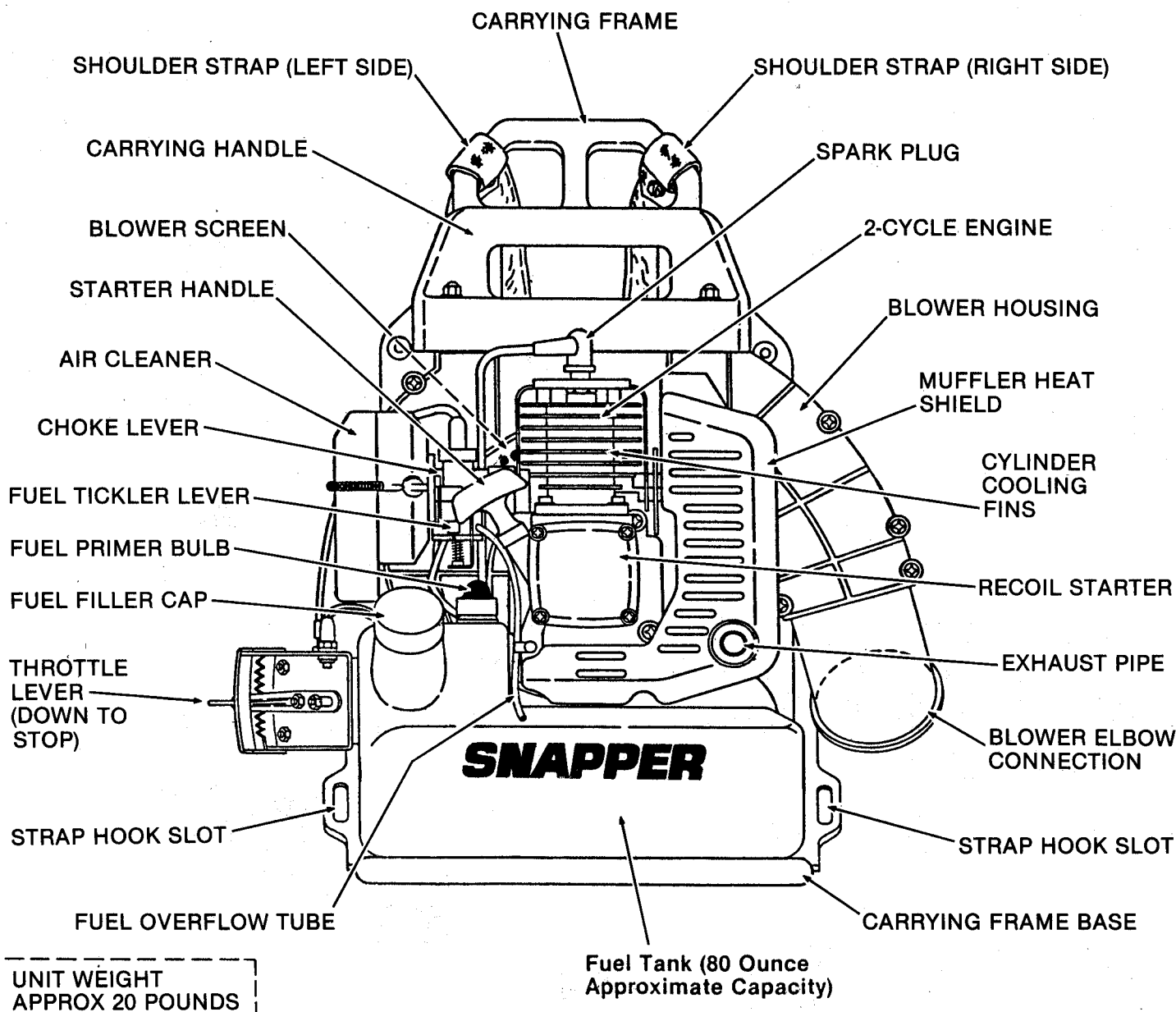

FIGURE 1--LOCATION OF CONTROLS & OTHER FEATURES

## OPERATION (Continued)

MOVE LEVER UP TO CHOKE

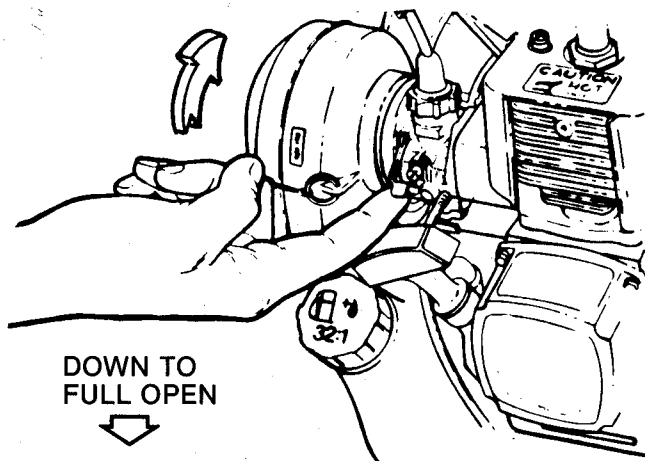

FIG. 2 -- CHOKE OPERATION

## START & STOP PROCEDURE

Become thoroughly familiar with the location of all controls and other important operational features before operating the blower. Be sure to read the safety instructions before hand. Be prepared to stop the unit and slip out of the carrying harness quickly in the event of an emergency! The engine is stopped by moving the throttle control downward to the "0" position. Unhook the carrying harness to slip out. After filling the tank with pre-mixed fuel as described on page 3, start and operate the blower as follows. **NOTE:** Place the blower on a high bench or table before starting to avoid the unnecessary strain of lifting it all the way from the surface before slipping into the carrying harness.

**STEP 1:** Move the CHOKE LEVER up to closed position (figure 2). Note: Little or no choking required with warm engine.

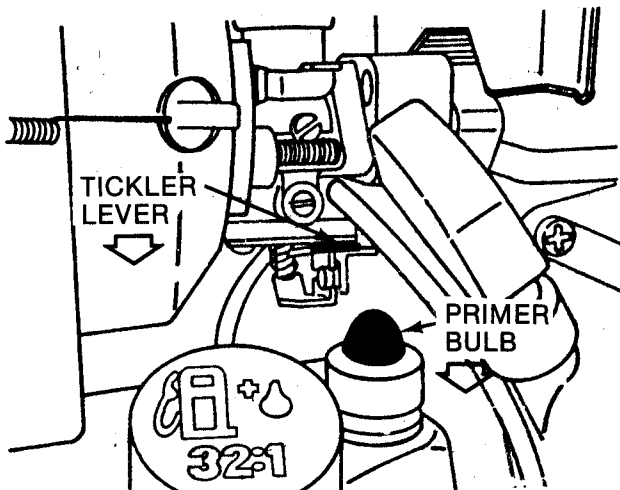

FIG. 3 -- PRIMER OPERATION

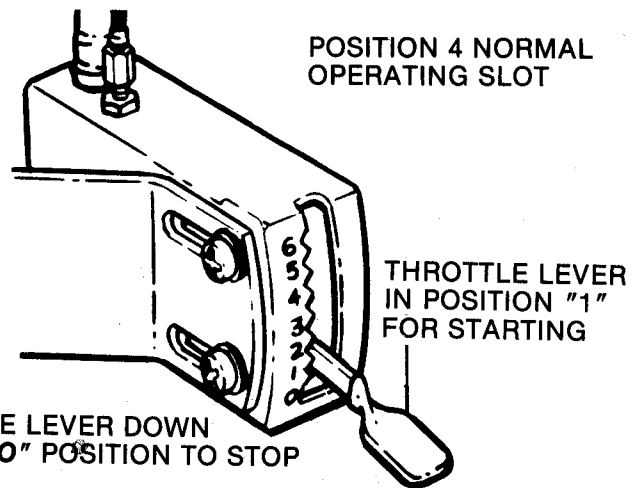

FIG. 4 -- THROTTLE CONTROL

**STEP 2:** Push the fuel TICKLER LEVER down and hold down while pumping the fuel PRIMER BULB until fuel is observed flowing out of the overflow tube (figure 3).

**STEP 3:** Move the THROTTLE LEVER into number 1 slot (figure 4).

**STEP 4:** Hold the unit steady by the carrying handle then pull the ROPE START HANDLE out in quick, steady motion and repeat until engine starts. **NOTE:** Carefully guide starter handle back each time to help prolong life of the starter (Figure 5).

**STEP 5:** After engine starts, gradually move the CHOKE LEVER back down to full open position. Allow the engine to warm for several minutes in speed positions 1 or 2 before slipping into the harness and operating the blower.

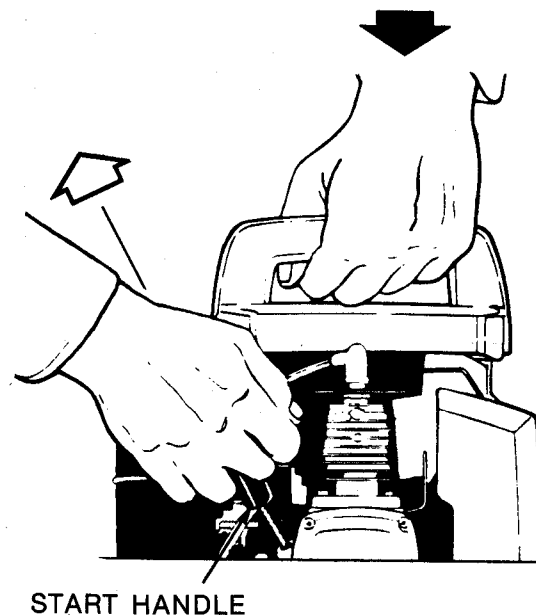

FIG. 5 -- ROPE STARTING

OPERATION continued

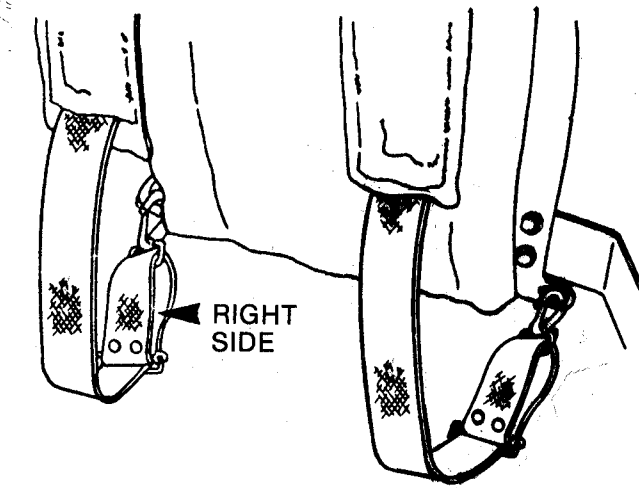

FIG. 6 -- CARRYING HARNESS

## OPERATION

After the engine has warmed, slide your right arm into the harness on the right then slide your left arm into the harness on the left. Be sure of your footing. Normal operating position under most conditions is with throttle lever in slot position #4. Maximum position is number 6. Observe all precautions while operating. To stop, move throttle lever down to 0 position. **DO NOT** have the unit refilled while it is running or strapped on your back! Always stop, get out of harness and allow the engine to cool down before refueling.

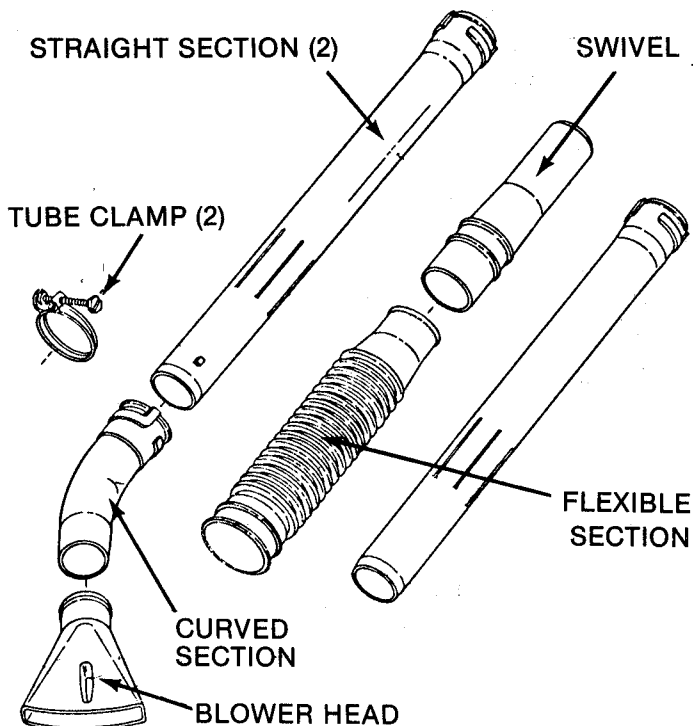

FIG. 7 -- STANDARD PIPE DETAIL

# SERVICE

## SERVICE ASSISTANCE & PARTS

To retain the quality of your blower, use genuine SNAPPER replacement parts only! Contact your local SNAPPER dealer for parts and service assistance. Always mention the model and serial number as found on the nameplate attached to the unit. The information in the parts section furnished with your blower is subject to change. Up-to-date parts manuals covering your blowers. For the nearest SNAPPER dealer, check the yellow pages under the heading LAWN-MOWERS.

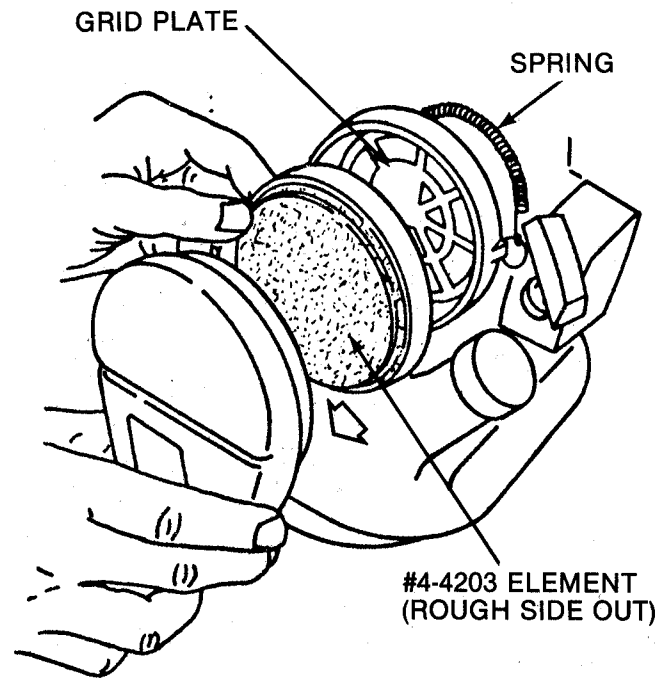

FIG. 8 -- AIR CLEANER DETAIL

## AIR CLEANER - SERVICE EVERY 25 HOURS

Every 25 hours or more frequently if operating under extremely dusty or dirty conditions, service the air cleaner as follows:

1. Move the choke lever to **CHOKE** position. This closes off the intake port to prevent dirt from entering the carburetor while servicing.
2. Roll the cover retaining spring up over top of the air cleaner cover. After removing cover, pull the filter element out of the cover.
3. Wash the filter element in kerosene or dishwashing detergent, squeeze dry and oil with small amount of SAE 30 engine oil. Squeeze element again to distribute oil evenly. **DO NOT** use gasoline.

continued

4. Clean the cover and surface of carburetor plate, insert the serviced filter element in the proper position then snap the cover in place on carburetor plate and roll retaining spring down over cover.

**NOTE:** Replace filter element if frayed or cracked. Refer to the parts section for correct replacement number.

## SPARK PLUG SERVICE

If the engine will not start or is difficult to start, use a spark plug wrench to remove the spark plug. On two cycle engines, the electrodes quickly become oil fouled, especially if the engine is run at low speed too long. The electrodes may also tend to become carbon fouled. Keep the electrodes clean and the gap set at .025". Use NGK BM-7A or Champion CJ6 or equivalent) replacement plug.

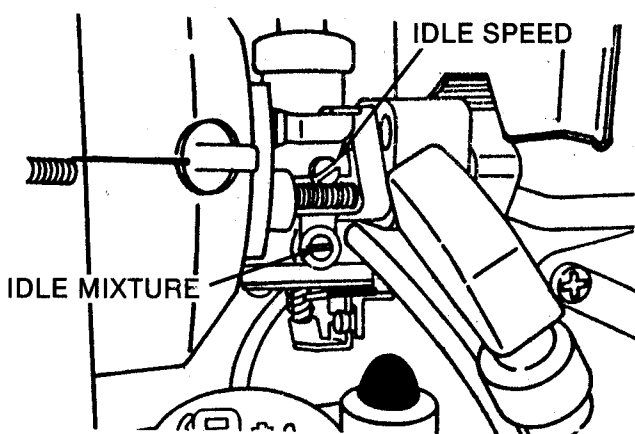

FIG. 9 -- CABURETOR ADJUSTMENTS

## FUEL SYSTEM SERVICE

An all position diaphragm type carburetor is used. The carburetor has a fixed main jet but has adjustable idle speed and idle mixture adjustments. Do not tamper with these adjustments. If the engine will not start, stalls at idler or stalls under rapid acceleration, and the cause is not due to the air cleaner or muffler, or fouled plug, readjust the carburetor as follows.

1. With engine stopped, turn the idler mixture screw to the right until the needle bottoms lightly--do not force it closed. Turn it to the left 1-1/2 turns.
2. Start the engine and allow time for it to warm up. Check idler speed operation. If the engine stall, turn the idle speed to the right 1/8 turn at a time until it idles properly.
3. Test acceleration. If the engine stumbles or stalls, turn the idle mixture screw to the left 1/8 turn at a time until proper acceleration is achieved. Recheck idle speed setting and readjust as needed.

**NOTE:** Keep the carburetor free of gum formation by using only clean fresh fuel. Whenever possible, drain the fuel or run until the fuel tank is dry, particularly when the blower is to be stored for any length of time.

## SPARK ARRESTER MUFFLER

The muffler includes a built-in spark arrester. The arrester functions to prevent sparks generated in the combustion process within the engine from being discharged along with the exhaust gases. This fire prevention device is required by many government agencies for gasoline engine powered products for uses in federal or state forest, brush and grass lands. Without proper service, the arrester screen will quickly become clogged with carbon causing power loss and poor performance.

**SERVICE** arrester after each 5 hours of operation. After muffler parts have cooled down, take the cover off the muffler and remove the spark arrester as shown in figure 10. Clean the arrester screen with a wire brush. Check to make sure screen has not deteriorated to the point where sparks could escape. Replace arrester and or gasket as needed. Reinstall components in sequence shown. **WARNING:** Never touch hot muffler or cover!

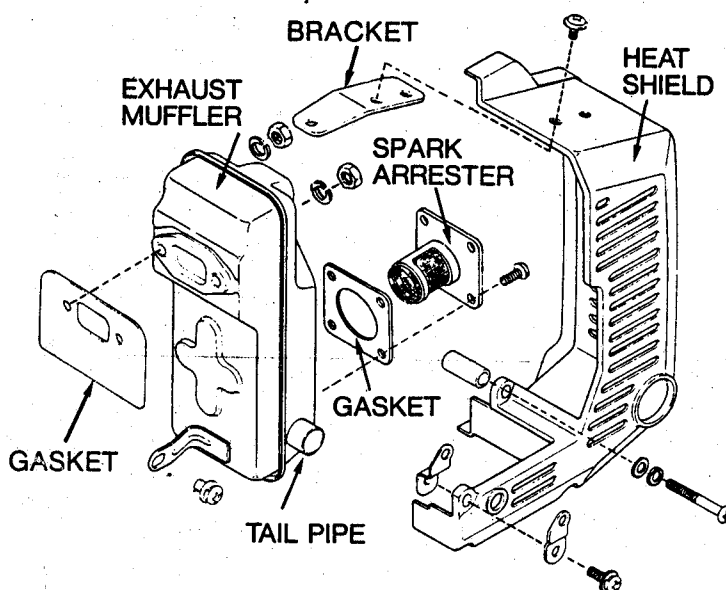

FIG. 10 -- MUFFLER/SHIELD DETAIL

## OFF-SEASON STORAGE

Before storing the unit during the off-season or for any period where the unit will not be used for 30 days or more, preserve the unit by taking the following steps:

1. Run the engine dry of fuel or drain all fuel from the tank.
2. Remove the spark plug, squirt small amount of 2-cycle engine oil into cylinder, pull rope starter several times and reinstall the plug.
3. Place dust cover over unit and store in high area out of reach of children and dry shed protected from weather.

# TROUBLESHOOTING

<b>ENGINE RUNS ABNORMALLY</b>	Engine getting fuel, but spark plug doesn't fire	Spark plug is getting fire.	<ul style="list-style-type: none"> <li>a. Engine flooding</li> <li>b. Carbon buildup on spark plug</li> <li>c. Broken insulator</li> <li>d. Improperly gapped plug</li> </ul>
		Spark plug is not getting fire.	<ul style="list-style-type: none"> <li>a. Fouled or dirty contact points</li> <li>b. Faulty connection of MTI unit</li> <li>c. Poor connection between coil and MTI unit</li> <li>d. Cut wire or short-circuited ignition coil</li> </ul>
	Engine getting fuel and spark plug fires.	Compression is good	a. Improper fuel or fuel mixture
		Compression is bad	<ul style="list-style-type: none"> <li>a. Cylinder gasket worn or broken</li> <li>b. Spark plug loose</li> <li>c. Worn piston rings</li> </ul>
	Fuel is not reaching carburetor		<ul style="list-style-type: none"> <li>a. No fuel in tank</li> <li>b. Fuel cap vent hole is clogged</li> <li>c. Clogged fuel port in carburetor</li> <li>d. Crimped or torn fuel line</li> </ul>
<b>ENGINE FAILS TO START</b>	Engine runs, but has no power	Compression is good and engine doesn't misfire	<ul style="list-style-type: none"> <li>a. Improper fuel or fuel mixture</li> <li>b. Element in air filter is clogged</li> <li>c. Loose connection on fuel pipe</li> <li>d. Choke lever in "ON" position</li> <li>e. Carbon buildup inside cylinder, exhaust pipe and muffler*</li> </ul>
		Compression is poor and engine is misfiring	<ul style="list-style-type: none"> <li>a. Fouled spark plug</li> <li>b. Plug wire is short-circuiting</li> <li>c. Improper fuel or fuel mixture</li> <li>d. Piston rings worn</li> <li>e. Cylinder walls are scarred</li> <li>f. Piston head cracked</li> </ul>
	Engine is overheating		<ul style="list-style-type: none"> <li>a. Poor fuel feed</li> <li>b. Not enough oil in fuel mixture</li> <li>c. Oil is not well mixed</li> <li>d. Excessive carbon buildup</li> <li>e. Overloaded operation</li> <li>f. High speed operation without load</li> <li>g. Faulty spark plug (Improper timing)</li> <li>h. Buildup of dirt on cooling fins of cylinder</li> </ul>
	Poor acceleration		<ul style="list-style-type: none"> <li>a. Carburetor out of adjustment</li> <li>b. Poor quality gasoline/oil</li> <li>c. Excessive carbon buildup*</li> </ul>

\*Clogged Spark Arrestor Screen

## Service Notes

---



---



---



---



---



---



---

## **SNAPPER TOTAL PROTECTION**

### **FULL TWO-YEAR WARRANTY**

**- NON-COMMERCIAL USERS -**

FOR TWO YEARS FROM THE ORIGINAL PURCHASE DATE OF THIS PRODUCT FOR YOUR NON-COMMERCIAL USE, SNAPPER POWER EQUIPMENT, THROUGH A SNAPPER DEALER, WILL REPAIR THE PRODUCT FREE OF CHARGE, IF IT DOES NOT WORK FOR ANY REASON.

RETURN THE PRODUCT TO A SNAPPER DEALER FOR REPAIR UNDER THIS WARRANTY.

YOU PROVIDE THE USUAL MAINTENANCE AS SPECIFIED IN THE OWNER/OPERATOR MANUALS.

THERE IS NO OTHER EXPRESS WARRANTY.

LIABILITY FOR INCIDENTAL AND CONSEQUENTIAL DAMAGES ARE EXCLUDED. SOME STATES DO NOT ALLOW THE EXCLUSION OF INCIDENTAL OR CONSEQUENTIAL DAMAGES, SO THIS EXCLUSION MAY NOT APPLY TO YOU.

THIS WARRANTY GIVES YOU SPECIFIC LEGAL RIGHTS, AND YOU MAY ALSO HAVE OTHER LEGAL RIGHTS WHICH VARY FROM STATE TO STATE AND COUNTRY TO COUNTRY.

### **LIMITED WARRANTY**

**- COMMERCIAL USERS -**

FOR NINETY (90) DAYS FROM THE ORIGINAL PURCHASE DATE OF THIS PRODUCT FOR YOUR COMMERCIAL USE, SNAPPER POWER EQUIPMENT, THROUGH AN AUTHORIZED SNAPPER DEALER, WILL REPAIR THE PRODUCT FREE OF CHARGE, IF IT IS FOUND TO BE DEFECTIVE IN MATERIAL OR WORKMANSHIP.

RETURN THE PRODUCT TO A SNAPPER DEALER FOR REPAIR UNDER THIS WARRANTY.

YOU PROVIDE THE USUAL MAINTENANCE AS SPECIFIED IN THE OWNER/OPERATOR MANUALS.

THERE IS NO OTHER EXPRESS WARRANTY.

IMPLIED WARRANTIES, INCLUDING THOSE OF MERCHANTABILITY AND FITNESS FOR A PARTICULAR PURPOSE, ARE LIMITED TO NINETY (90) DAYS FROM THE ORIGINAL PURCHASE DATE. SOME STATES DO NOT ALLOW LIMITATIONS ON HOW LONG AN IMPLIED WARRANTY LASTS, SO THE ABOVE LIMITATION MAY NOT APPLY TO YOU.

LIABILITY FOR INCIDENTAL AND CONSEQUENTIAL DAMAGES ARE EXCLUDED. SOME STATES DO NOT ALLOW THE EXCLUSION OR LIMITATION OF INCIDENTAL OR CONSEQUENTIAL DAMAGES, SO THE ABOVE EXCLUSION MAY NOT APPLY TO YOU.

THIS WARRANTY GIVES YOU SPECIFIC LEGAL RIGHTS, AND YOU MAY ALSO HAVE OTHER LEGAL RIGHTS WHICH VARY FROM STATE TO STATE AND COUNTRY TO COUNTRY.

**PLEASE COMPLETE THE ATTACHED SNAPPER PRODUCT REGISTRATION CARD AND PROMPTLY MAIL IT TO SNAPPER POWER EQUIPMENT, McDONOUGH, GEORGIA 30253.**

## **SNAPPER POWER EQUIPMENT**

McDonough, Georgia 30253

**A Division of Fuqua Industries**





## Free Manuals Download Website

<http://myh66.com>

<http://usermanuals.us>

<http://www.somanuals.com>

<http://www.4manuals.cc>

<http://www.manual-lib.com>

<http://www.404manual.com>

<http://www.luxmanual.com>

<http://aubethermostatmanual.com>

Golf course search by state

<http://golfingnear.com>

Email search by domain

<http://emailbydomain.com>

Auto manuals search

<http://auto.somanuals.com>

TV manuals search

<http://tv.somanuals.com>