

Attachment Illustrated Parts List



Attachment

Mfg. No.	Description
1694499	Catcher, Turbo Clean Sweep Triple

Simplicity

MANUFACTURING, INC.
500 N. Spring Street / PO Box 997
Port Washington, WI 53074-0997 USA

www.simplicitymfg.com

© Copyright 2005 Simplicity Manufacturing, Inc. All Rights Reserved. Printed In USA.

Part No.: 1731896

Rev. 07/2005

TP 400-4219-00-AT-SMA

Cover & Bag Group - Triple

986509

NOTE: Unless noted otherwise,
use the standard hardware torque
specification chart.

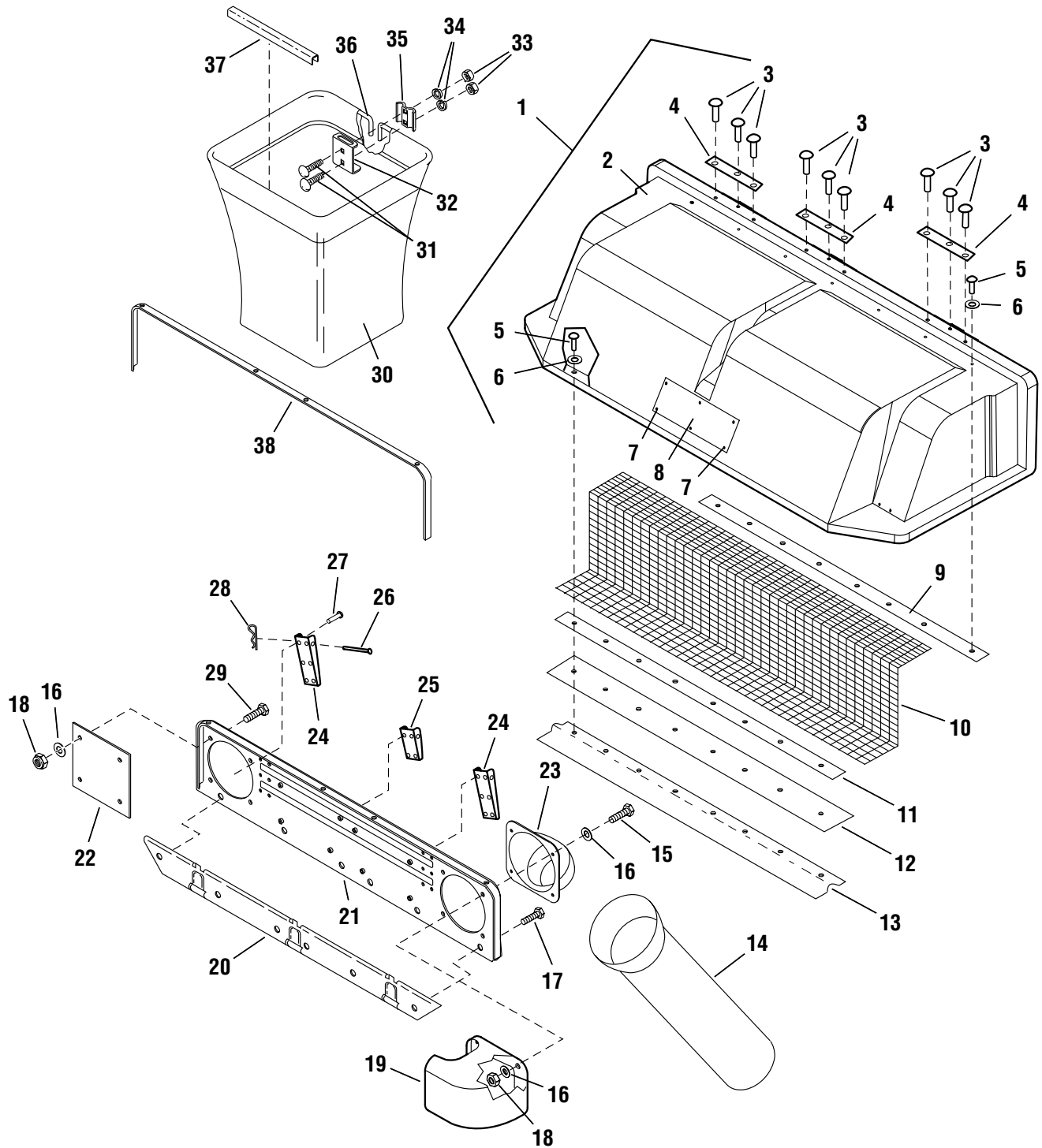

Cover & Bag Group - Triple

REF NO	PART NO.	QTY.	DESCRIPTION
1	1717025	1	COVER & SCREEN ASSEMBLY, Grass Collector Complete (Incl. Ref. Nos. 2, 3, 4, 5, 6, 7, 8, 9, 10, 11, 12 & 13)
2	1717026	1	COVER, Grass Catcher Black Plastic
3	1960241	9	RIVET, Pop, .25OD .500L Steal,Steal Stem .50HD Black
4	1717067	3	PLATE & TUBE ASSEMBLY, Hinge
5	2825160	25	RIVET, Pop, .188D .527L Steal,Steal Stem .37HD Dia.
6	1910531	16	WASHER, Rivet, .188 (0.20ID x 0.50OD x .05TH) Black
7	1667248	6	CLIP, Canoe .437LG .375DIA
8	1704405	1	DECAL, WARNING Do Not Open Cover
9	1716970	1	CLAMP, Screen 16GA 40.0LG
10	1717041	1	SCREEN, Black Poly, 19.5 x 45.0
11	1717524	1	CLAMP, Seal, .060THK .75WD 48.00LG
12	1716968	1	SEAL, Black Rubber, .075 x 3.00 x 48.0
13	1716972	1	ANGLE, Screen, 14GA 48"LG
14	1719807	1	CHUTE, Grass Collector Upper, 5.76ID 21.7L Scribed
15	1921333	4	CAPSCREW, Hex Head, 5/16-18 x 1 G5 Black
16	1919326	12	WASHER, 5/16 (0.34ID x 0.75OD x .06THK) Black
17	1925003	3	CAPSCREW, Hex Washer Head Taptite, 1/4-20 x 1/2 Black
18	1919438	8	NUT, Hex Lock ESNA Light, 5/16-18NC-3B Black
19	1717039	1	DEFLECTOR, Black Plastic Grass Collector
20	1716973	1	CHANNEL & BRACKET ASSEMBLY, Support
21	1716966	1	PLATE & BRACES ASSEMBLY, 3 Bag Grass Catcher
22	1725969	1	COVER, Inlet, .125THK 8.12 x 8.12 Plexiglass
23	1717038	1	DUCT, Inlet Black Plastic Grass Collector
24	1720875	2	BRACKET, Hinge 3 Bag, 12GA 6.00LG with Point
25	1720945	1	BRACKET, Hinge 3 Bag, 12GA 2.75LG
26	1672344	3	PIN, Round Head Drilled, 3/8 x 2-3/4 Black
27	1928707	16	RIVET, Pop, .188D .277L AL, AL Stem .37HD Black
28	1960074	3	CLIP, Hair Pin, .093DIA Spring Wire 1.625LG Black
29	1921332	4	CAPSCREW, Hex Head, 5/16-18 x 3/4 G5 Black
30	1703764	1	BAG, Grass, 15.4 x 16 x 22.5 White Poly Cloth
31	1931333	2	CARRIAGE BOLT, 5/16-18 x 3/4 G5 Black
32	1703807	1	HANGER, Grass Bag Hoop
33	1917372	2	NUT, Hex 5/16-18 NC-2B Black
34	1917356	2	LOCKWASHER, Spring 3/8 Black
35	1672023	1	CLAMP, Wire Diameter 1/2 (2), .344 Holes (3)
36	1703855	1	HOOP, 1/2 ROD 16.12 x 16.75
37	1675707	1	EDGING, 13.50LG PVC Tube White
38	1717082	1	SEAL, Black Plastic 73"

Footnotes

The above parts group applies to the following Mfg. Nos.:

1694499 - Catcher

Front Weight Carrier Group

986507

NOTE: Unless noted otherwise,
use the standard hardware torque
specification chart.

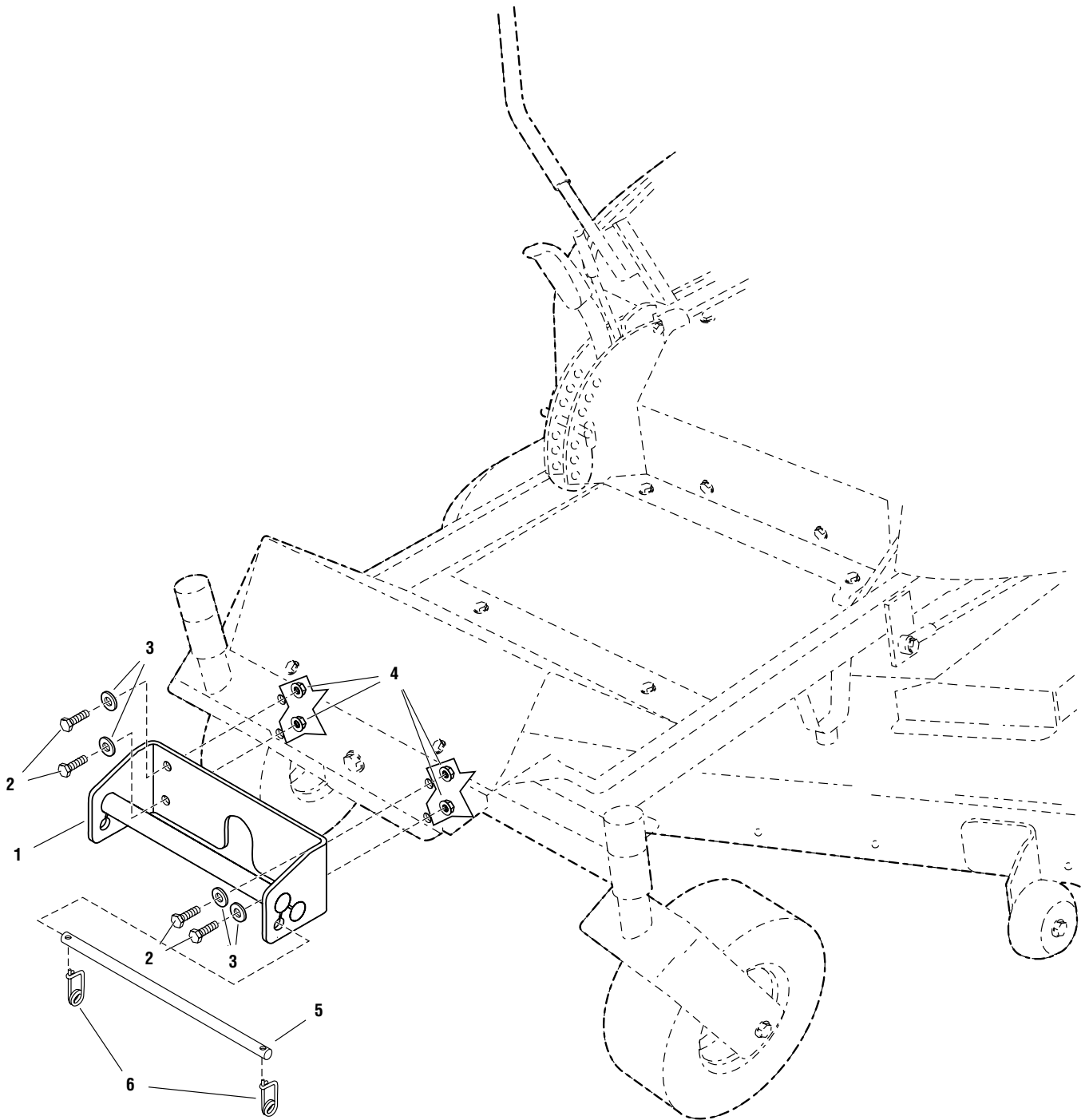

The above parts group applies to the following Mfg. Nos.:

1694499 - Catcher

Front Weight Carrier Group

REF NO	PART NO.	QTY.	DESCRIPTION
1	5049082	1	HOLDER ASSEMBL, Weight
2	1921333	4	CAPSCREW, Hex Head, 5/16-18 x 1 G5 Black
3	1919326	4	WASHER, 5/16 (0.34ID x 0.75OD x .06THK) Black
4	1927557	4	NUT, Hex Flange Whiz Lock, 5/16-18 Large Black
5	5049143	1	ROD, Retaining, 1/2 x 13-3/4LG
6	2176012	2	RETAINER, Pin, Spring

Footnotes

The above parts group applies to the following Mfg. Nos.:

1694499 - Catcher

Mount Group

986508

NOTE: Unless noted otherwise, use the standard hardware torque specification chart.

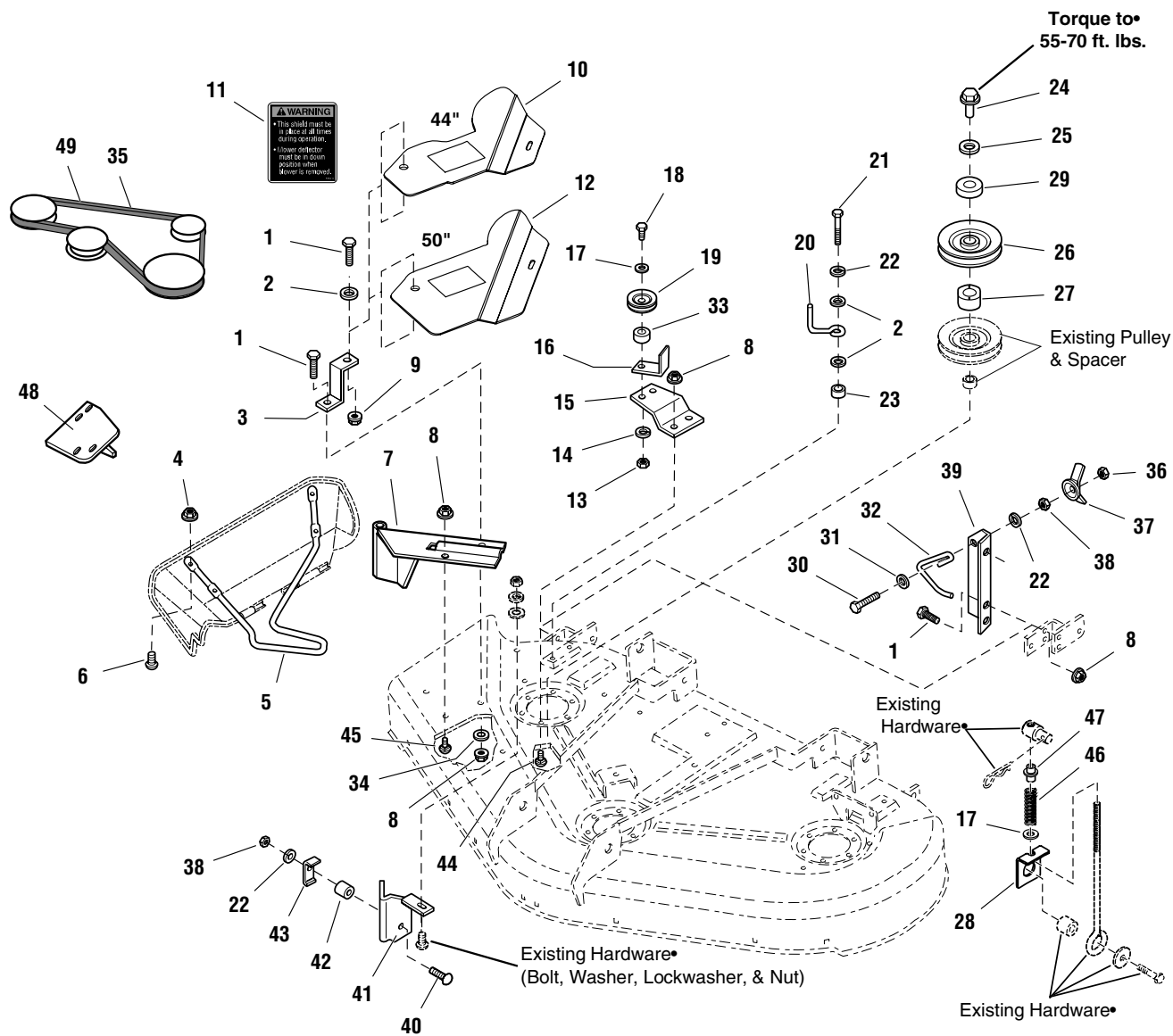

The above parts group applies to the following Mfg. Nos.:
 1694499 - Catcher

Mount Group

REF NO	PART NO.	QTY.	DESCRIPTION
1	1921333	4	CAPSCREW, Hex Head, 5/16-18 x 1 G5 Black
2	1919326	3	WASHER, 5/16 (0.34ID x 0.75OD x .06THK) Black
3	1718304	1	SUPPORT, Belt Cover 10GA 1.0WD 3.0LG
4	1933896	4	NUT, Hex Lock, 10-24 with Nylon Insert NC3B Black
5	1718295	1	ROD, .375DIA 22.0LG
6	1960404	4	SCREW, Truss Head Phillips, #10-24 x 3/4 Black
7	1722546	1	PIVOT & BRACKETS ASSEMBLY, 38, 44 & 50"
8	1931277	6	NUT, Hex Flange Whiz Lock, 5/16-18 Small Black
9	1919438	1	NUT, Hex Lock ESNA Light, 5/16-18NC-3B Black
10	5049171	1	COVER, Belt 44" 12GA
11	1717291	2	DECAL, WARNING Sheild & Mower Deflector
12	5049170	1	COVER, Belt 50" 12GA
13	1916950	1	NUT, Hex 3/8-16 NC-2B Black
14	1916965	1	LOCKWASHER, Spring 3/8
15	1704768	1	BRACKET, Z .164TH 5.88WD 3.21LG
16	1724373	1	BRACKET, L 12GA 1.24WD 2.24LG 2.28LG
17	1924940	1	WASHER, 3/8 (0.41ID x 0.87OD x .08THK) Black
18	1923701	1	CAPSCREW, Hex Head, 3/8-16 x 2 G5 Black
19	1714817	1	PULLEY, Idler, 2.75OD 0.380ID 0.50W
20	2172845	1	STOP, Belt, .188WIRE 1.750,2.250 Black
21	1921221	1	CAPSCREW, Hex Head, 5/16-18 x 1-1/2 G5 Black
22	1917356	1	LOCKWASHER, Spring 5/16 Black
23	1710703	1	SPACER, 0.328ID x 0.499OD x 0.625LG Powdered Metal
24	1713523	1	NUT, Sleeve, 9/16-18 x 3/4INT x 1.34LG Black
25	1603592	1	WASHER, Bellville, 0.88ID x 1.75OD x .08TH Black
26	1709941	1	PULLEY, 04.30OD 1.000ID 0.579 Groove 9GA
27	1713623	1	HUB, .79ID x 1.5OD x .73LG Metafusion
28	5049145	1	PLATE, Spring Support 10GA
29	5049088	1	SPACER, 0.812ID x 1.75OD x 0.50LG
30	1960318	1	CAPSCREW, Hex Head, 5/16-18 x 2-1/2 G5 Flat Black
31	1919381	1	WASHER, 5/16 (0.34ID x 1.00OD x .13THK) Black
32	1705064	1	SPRING, Latch, .125WIRE 4.3LG Black
33	2108717	1	SPACER, 0.390ID x 0.625OD x .265LG
34	1922755	1	WASHER, 3/8 (0.41ID x 1.00OD x .13THK) Black
35	1705142	1	V-BELT, 3L, 44" Mower Deck
36	1923362	1	NUTHex Centerlock, 5/16-18 Black
37	1679163	1	NUT & CUP ASSEMBLY, Wing, 5/16-18 E-Coat
38	1917372	2	NUT,Hex, 5/16-18 NC-2B Black
39	1704982	1	PLATE, Anchor
40	1960223	1	CARRIAGE BOLT, 5/16-18 x 1-1/4 G5 Black
41	1659867	1	BRACKET ASSEMBLY, Cutoff, 44"
42	1666294	1	SPACER, 0.385ID x 0.668OD x 0.455LG Powdered Metal Black
43	1705308	1	BRACKET, L 12GA 1.00WD 1.98LG 0.62LG
44	1923325	2	CAPSCREW, Hex Head, 5/16-18 x 7/8 G5 Black

Footnotes

The above parts group applies to the following Mfg. Nos.:

1694499 - Catcher

Mount Group

986508

NOTE: Unless noted otherwise, use the standard hardware torque specification chart.

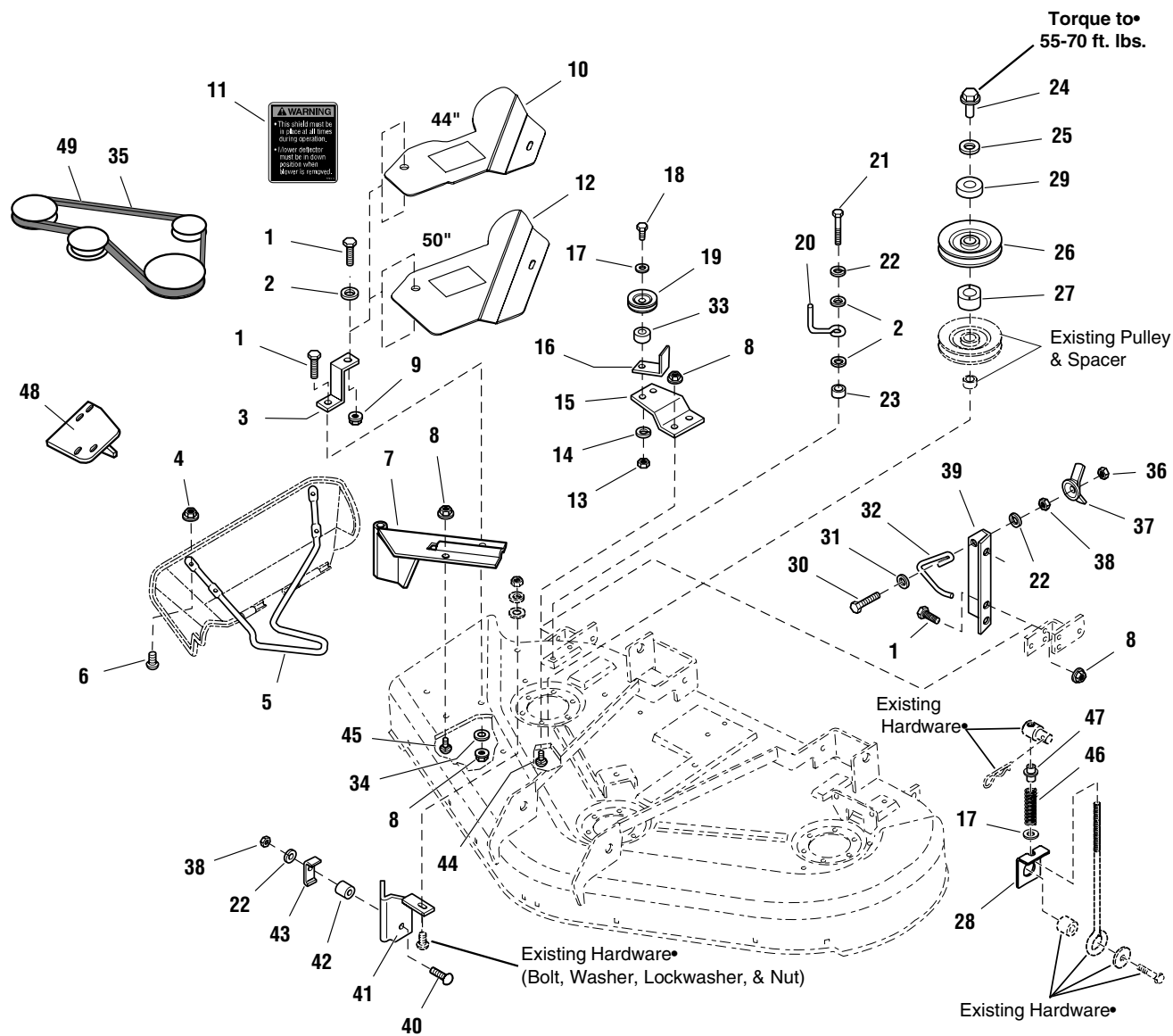

The above parts group applies to the following Mfg. Nos.:

1694499 - Catcher

Mount Group

REF NO	PART NO.	QTY.	DESCRIPTION
45	1931333	1	CARRIAGE BOLT, 5/16-18 x 3/4 G5 Black
46	5049159	1	SPRING, Compression, 0.720OD x 2.25 LG .085 Wire
47	5049144	1	SPACER, 0.390ID x 0.75OD x 1.13 LG YELLOW
48	1704983	1	BRACKET & PLATE ASSEMBLY, Clamp
49	1707956	1	V-BELT, 3L, 50" Mower Deck

Footnotes

The above parts group applies to the following Mfg. Nos.:

1694499 - Catcher

Tubes & Support Group - Triple

986506

NOTE: Unless noted otherwise,
use the standard hardware torque
specification chart.

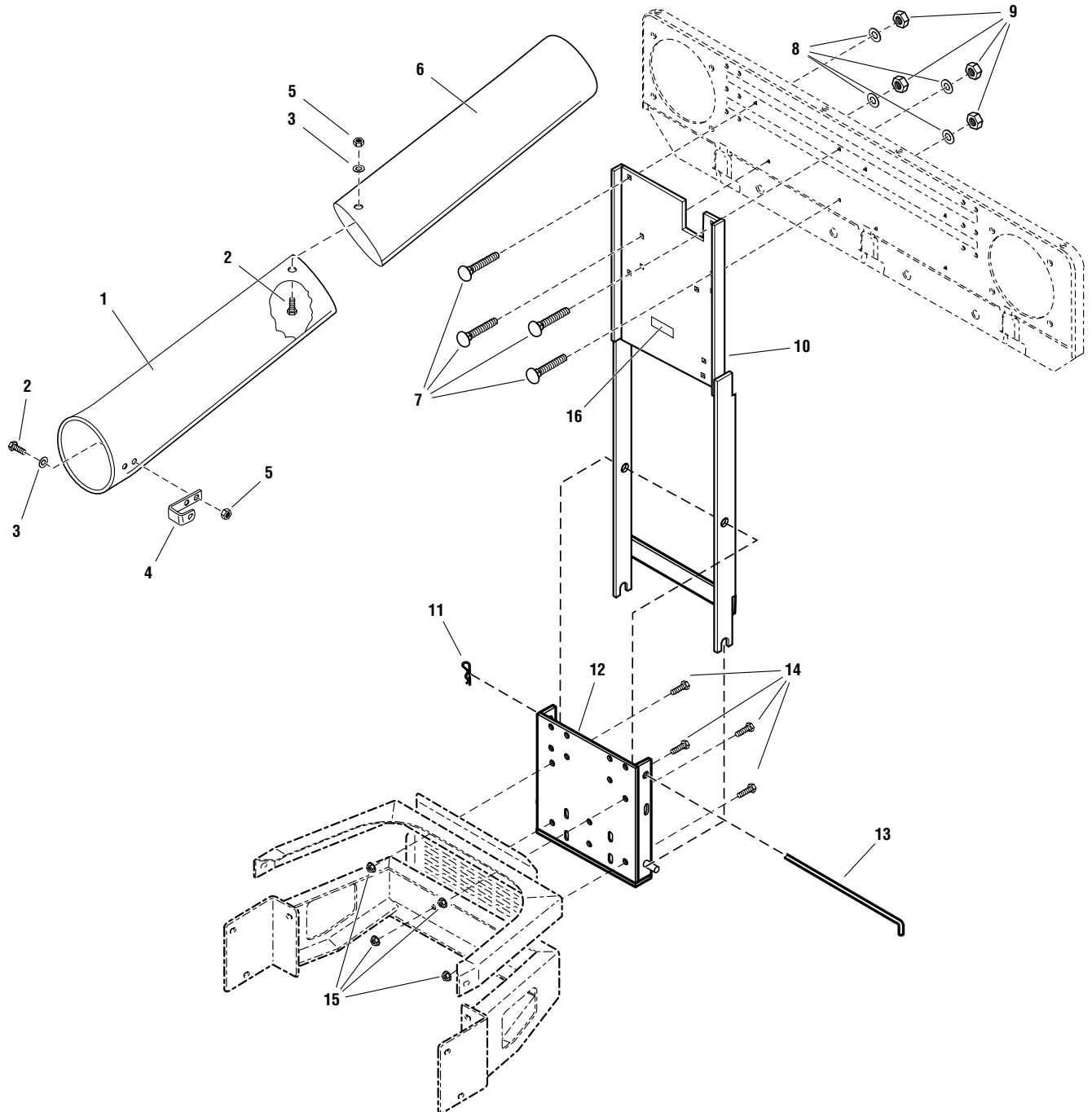

The above parts group applies to the following Mfg. Nos.:

1694499 - Catcher

Tubes & Support Group - Triple

REF NO	PART NO.	QTY.	DESCRIPTION
1	5049152	1	CHUTE, Grass Collector Lower, Black Poly
2	1960404	5	SCREW, Truss Head Phillips, #10, 24 x 3/4 Black
3	1960096	5	WASHER, 3/16 (0.19ID x 0.75OD x .06THK) Black
4	1705063	1	CLIP, Spring, 1.40 x 1.48 Open 3.50LG 0.88WD
5	1933896	5	NUT, Hex Lock, 10-24 with Nylon Insert NC3B Black
6	5049151	1	CHUTE, Grass Collector Middle, Black Poly
7	1931335	4	CARRIAGE BOLT, 5/16-18 x 1 G5 Black
8	1917356	4	LOCKWASHER, Spring, 5/16 Black
9	1917372	4	NUT, Hex 5/16-18 NC-2B Black
10	1723437	1	SUPPORT ASSEMBLY, Triple Collector
11	1960033	1	CLIP, Hair Pin, .125DIA Spring Wire 2.562LG Black
12	1726968	1	PLATE & PINS ASSEMBLY, Hitch Triple Collector Black
13	1717085	1	ROD, Hitch, .625DIA 16.5LG
14	1921176	4	CAPSCREW, Hex Head, 1/2-13 x 1-1/4 G5 Black
15	1960668	4	NUT, Hex Flange Whiz Lock, 1/2-13 Black
16	*	1	DECAL, ID Plate

Footnotes

* Not a serviceable part.

The above parts group applies to the following Mfg. Nos.:

1694499 - Catcher

Hardware Identification & Torque Specifications

Common Hardware Types

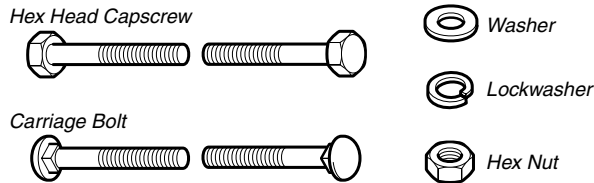

Standard Hardware Sizing

When a washer or nut is identified as 1/2", this is the *Nominal size*, meaning the *inside diameter* is 1/2 inch; if a second number is present it represent the *threads per inch*

When bolt or capscrew is identified as 1/2 - 16 x 2", this means the *Nominal size*, or *body diameter* is 1/2 inch; the second number represents the *threads per inch* (16 in this example, and the final number is the *body length* of the bolt or screw (in this example 2 inches long).

The guides and ruler furnished below are designed to help you select the appropriate hardware and tools.

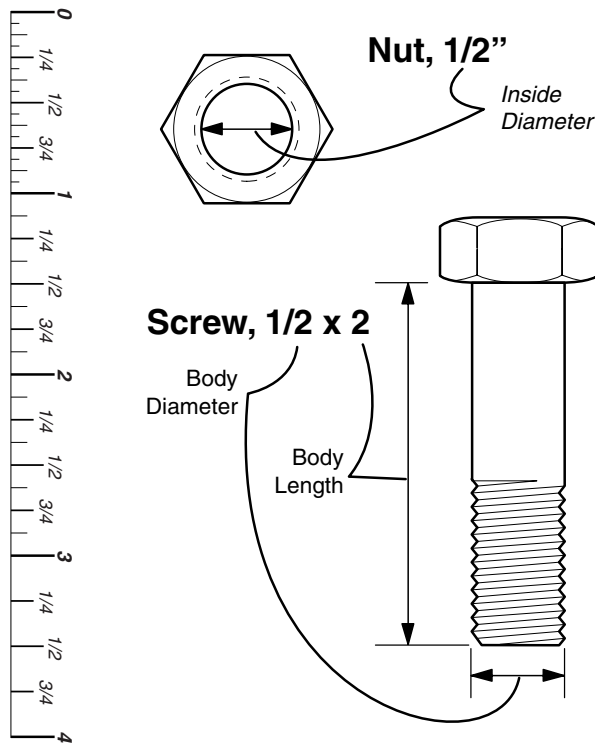

Torque Specification Chart						
FOR STANDARD MACHINE HARDWARE (Tolerance ± 20%)						
Hardware Grade	No Marks SAE Grade 2		SAE Grade 5		SAE Grade 8	
	in/lbs ft/lbs	Nm.	in/lbs ft/lbs	Nm.	in/lbs ft/lbs	Nm.
8-32	19	2.1	30	3.4	41	4.6
8-36	20	2.3	31	3.5	43	4.9
10-24	27	3.1	43	4.9	60	6.8
10-32	31	3.5	49	5.5	68	7.7
1/4-20	66	7.6	8	10.9	12	16.3
1/4-28	76	8.6	10	13.6	14	19.0
5/16-18	11	15.0	17	23.1	25	34.0
5/16-24	12	16.3	19	25.8	27	34.0
3/8-16	20	27.2	30	40.8	45	61.2
3/8-24	23	31.3	35	47.6	50	68.0
7/16-14	30	40.8	50	68.0	70	95.2
7/16-20	35	47.6	55	74.8	80	108.8
1/2-13	50	68.0	75	102.0	110	149.6
1/2-20	55	74.8	90	122.4	120	163.2
9/16-12	65	88.4	110	149.6	150	204.0
9/16-18	75	102.0	120	163.2	170	231.2
5/8-11	90	122.4	150	204.0	220	299.2
5/8-18	100	136	180	244.8	240	326.4
3/4-10	160	217.6	260	353.6	386	525.0
3/4-16	180	244.8	300	408.0	420	571.2
7/8-9	140	190.4	400	544.0	600	816.0
7/8-14	155	210.8	440	598.4	660	897.6
1-8	220	299.2	580	788.8	900	1,244.0
1-12	240	326.4	640	870.4	1,000	1,360.0

NOTES

- These torque values are to be used for all hardware excluding: locknuts, self-tapping screws, thread forming screws, sheet metal screws and socket head setscrews.
- Recommended seating torque values for locknuts:
 - for prevailing torque locknuts - use 65% of grade 5 torques.
 - for flange whizlock nuts and screws - use 135% of grade 5 torques.
- Unless otherwise noted on assembly drawings, all torque values must meet this specification.

Wrench & Fastener Size Guide



1/4" Bolt or Nut
Wrench—7/16"

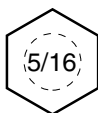

5/16" Bolt or Nut
Wrench—1/2"

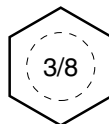

3/8" Bolt or Nut
Wrench—9/16"



7/16" Bolt or Nut
Wrench (Bolt)—5/8"
Wrench (Nut)—11/16"

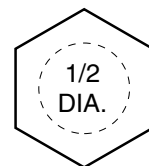

1/2" Bolt or Nut
Wrench—3/4"

Free Manuals Download Website

<http://myh66.com>

<http://usermanuals.us>

<http://www.somanuals.com>

<http://www.4manuals.cc>

<http://www.manual-lib.com>

<http://www.404manual.com>

<http://www.luxmanual.com>

<http://aubethermostatmanual.com>

Golf course search by state

<http://golfingnear.com>

Email search by domain

<http://emailbydomain.com>

Auto manuals search

<http://auto.somanuals.com>

TV manuals search

<http://tv.somanuals.com>