

82099
**Safety Instructions
& Operator's Manual
for**

SNAPPER

RIDER

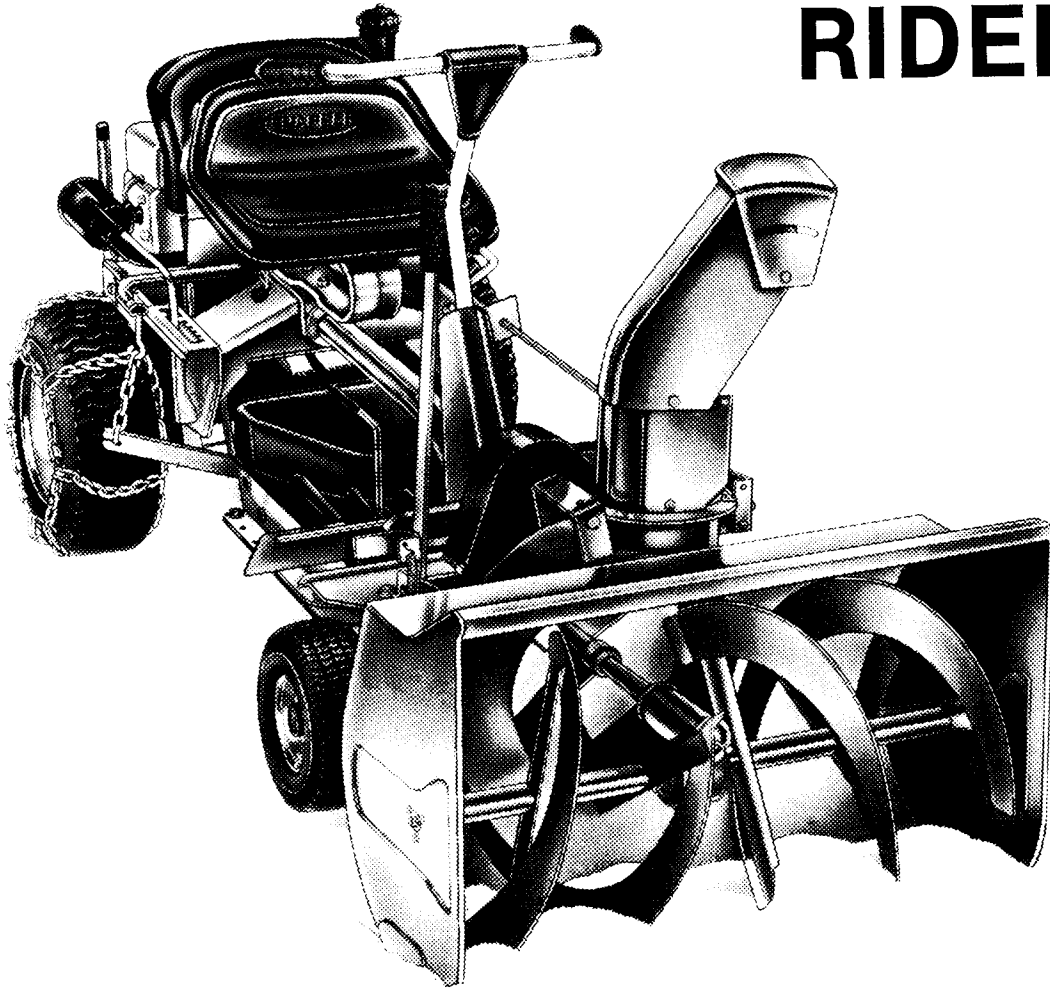

SNOW THROWER ATTACHMENT

Thank you for buying the Snow Thrower attachment for your SNAPPER Riding Mower. This two-stage Thrower will do a great job of clearing snow from your drives and walks on the rear engine Rider which not only provides weight on the rear drive wheels for excellent traction but gives you good forward visibility. This manual covers the recommended procedures for operating the unit as a snow thrower plus detailed instructions for converting the Rider to and from the mower mode as the seasons change. Before operating in the snow thrower mode, be sure to read the important safety instructions on the inside page of this manual. When converting back to the mower mode at the end of the snow season, review the important safety instructions and other information in the Riding Mower Operator's Manual (Snapper #1-2629).

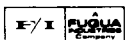

McDonough Power Equipment McDonough, GA • 30253





SAFETY INSTRUCTIONS



WARNING: This powerful snow thrower is capable of amputating hands and feet and of throwing objects causing property damage and personal injury! Failure to observe the following safety precautions could result in serious injury. Read this manual carefully and question your Snapper Dealer if something is not clear. Should the dealer be unable to answer to your satisfaction, send a letter to the Snapper Customer Service Department at McDonough Power Equipment, Post Office Box 777, McDonough, Georgia 30253, or Phone 1-404-957-9141.

PROTECTION FOR CHILDREN

1. DO NOT allow children in area when Snow Thrower is being operated.
2. DO NOT allow pre-teen children to operate the Snow Thrower.
3. DO NOT allow irresponsible teenagers to operate the machine — allow teenager only if exhibiting mature judgment and then only after thorough instruction and under close supervision of an experienced operator.

PREPARATION

1. Read this manual, get to know where all controls are located and practice how to use them before starting for the first time and at the beginning of each season. Pay attention to Decals on the Rider and snow thrower.
2. Wear protective clothing including face mask in extreme cold and boots which will give you maximum footing on slippery surfaces.
3. Before the first snow fall, check the area to be cleared and remove all objects such as doormats, sticks, toys, wires, rocks, etc., which could be hurled or jam the snow thrower.
4. Survey the area to be cleared beforehand and plan where snow is to be blown. Be prepared to release blower clutch or to change deflector quickly to discharge away from windows, cars, buildings and doorways to avoid property damage or personal injury from hurled objects.
5. Adjust the collector housing height by adjusting skid shoes to clear rough spots or gravelled surfaces before starting.
6. Handle fuel with care. Store only in approved gasoline container. Move machine outdoors where fumes can be safely dissipated before filling tank. Never add fuel when engine is running. Allow cooling off period after stopping to prevent spilled fuel from igniting on contact with hot engine parts.

OPERATIONAL PRECAUTIONS

1. Before starting, make visual check to make sure blower housing is clear and all guards and shields are in place and tight.
2. Warn everyone in advance to stay clear of area but keep especially watchful for children and pets darting into area while operating.
3. Start engine only when exhaust fumes can be dissipated, allow brief warm-up period, practice operation of controls outside before putting the machine to work.
4. Start in slow speed and adjust traction speed to insure safe operation.
5. Transport unit with blower clutch released and activate only when snow is to be cleared. Set deflector to discharge desired distance beforehand.
6. Adjust traction speed slow enough to avoid overloading capacity resulting in clogging of the blower housing.
7. Should the blower become clogged, release traction and blower clutch controls and, as an additional precaution, stop the engine before attempting to unclog the collector and impellers.
8. If you strike a hard object and break the auger shear pin, stop the engine and disconnect the spark plug wire before inspecting for damage, and/or replacing the shear pin.
9. Stop the engine if unit starts to vibrate excessively as this normally indicates mechanical problems. Disconnect the spark plug wire to prevent unintentional starting before servicing or repairing the machine.
10. Avoid clearing steep slopes and keep away from drop-off areas where machine could tip over. Clear snow up and down slopes whenever possible.
11. Stop the engine and remove the key whenever you leave the unit unattended to eliminate the possibility of children or untrained adults attempting to operate the machine.

OPERATION

Make sure that each person you allow to operate your Snow Throwing Rider reads this manual beforehand then pays particular attention to the Safety Precautions on page 2 and to the warning decals on the unit.

PRE-START PROCEDURE

Before the initial start-up in winter, make sure that the oil in the crankcase of the engine has been changed to the weight and grade specified for winter operation in the engine owner's manual. Perform the following before each start-up during the snow season.

- **ENGINE LUBE:** Check level and add as needed to bring up to the Full mark.
- **FUEL:** Move unit outside and fill tank.
- **TIRES:** Check pressure and bring up to specifications.
- **SKID SHOES:** Reset as needed to suit area to be cleared.
- **DEFLECTOR:** Set cap to throw desired distance.
- **UNIT:** Visually check to make sure all guards are in place and secure.

EMERGENCY STOPPING PROCEDURES

Before starting, know how to stop the Rider and Snow Throwing quickly in preparation for possible emergency situations. Refer to Figure 1 for location of controls. Forward motion of the Rider is stopped by depressing the CLUTCH/BRAKE pedal on the left side. The snow thrower augers are stopped by lifting your feet off the BLADE PEDAL or by overriding the pedal by pulling the BLADE LEVER inward and backward to the OFF position. The engine is stopped by either turning the IGNITION keyswitch to OFF or by pushing the ENGINE THROTTLE CONTROL rearward to STOP. Operation of the other controls are described wherever pertinent in the following.

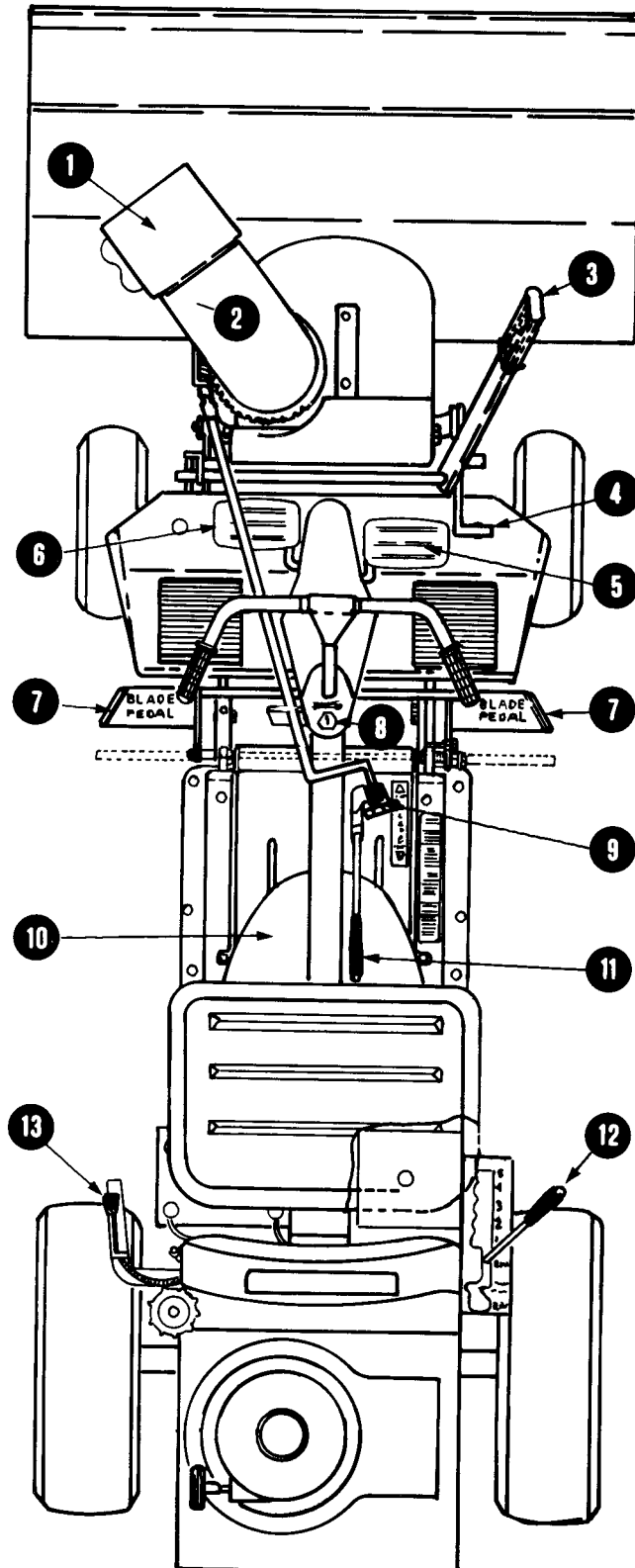

- 1 - DEFLECTOR CAP
- 2 - DISCHARGE CHUTE
- 3 - LIFT HANDLE
- 4 - LIFT LATCH
- 5 - AUX. BRAKE PEDAL
- 6 - CLUTCH/BRAKE PEDAL
- 7 - BLADE PEDAL
- 8 - IGNITION KEYSWITCH
- 9 - CHUTE CRANK
- 10 - CARRIER COVER
- 11 - BLADE LEVER
- 12 - TRANSMISSION SHIFT
- 13 - ENGINE CONTROL (THROTTLE)

FIGURE 1 - OVERHEAD VIEW SHOWING LOCATION OF CONTROLS

OPERATING PROCEDURES

Whenever possible, push the unit outdoors before adding fuel or starting the engine. If the unit must, however, be started inside the garage or shed, make sure the doors are wide open for maximum ventilation and the unit is driven outside immediately after starting. After performing the prescribed pre-start checks and services, proceed as follows to operate the unit.

1. **ENGINE (THROTTLE) CONTROL:** Move control knob to **START**.
2. **ENGINE IGNITION:** Insert key in switch and turn to **ON**.
3. **STARTING ENGINE:** If manual start, pull **STARTER ROPE** out in smooth steady motion until engine starts. On electric start, push **STARTER BUTTON** and hold until engine starts — note: if engine fails to start after cranking for over 30 seconds, locate and correct cause or crank the engine manually.
4. **ENGINE WARM-UP:** Allow brief warm-up period outdoors to avoid stalling cold engine then reset **ENGINE CONTROL** to desired run position.
5. **RIDER MOTION:** To begin forward or rearward motion, pull back on the **Thrower lift handle** to latch in transport position (Figure 2), depress the **CLUTCH/BRAKE pedal** and move the **SHIFT LEVER** to #1 forward speed or into **REV** to back up — hold lever in **REV** while backing up and depress **CLUTCH/BRAKE pedal** to stop reverse motion. The **CLUTCH/BRAKE pedal** does not have to be depressed to shift to higher speeds. Push the **CLUTCH/BRAKE pedal** all the way down to stop forward or rearward motion.

SNOW THROWER OPERATION: After driving to the area to be cleared, stop forward motion and proceed as follows:

1. Set **ENGINE CONTROL** in fast position.
2. Pull back on **LIFT LEVER** and depress **LIFT LATCH** with right foot then move the lever forward until the unit rests on its skid shoes.
3. Move the **BLADE LEVER** forward to **ON** position and hold then depress the **BLADE PEDAL** with right foot. Note, the blower auger blades and impeller will begin rotation when the blade lever is shifted **ON**. Note that the blade lever is blocked from forward movement if the blade pedal is pressed first.

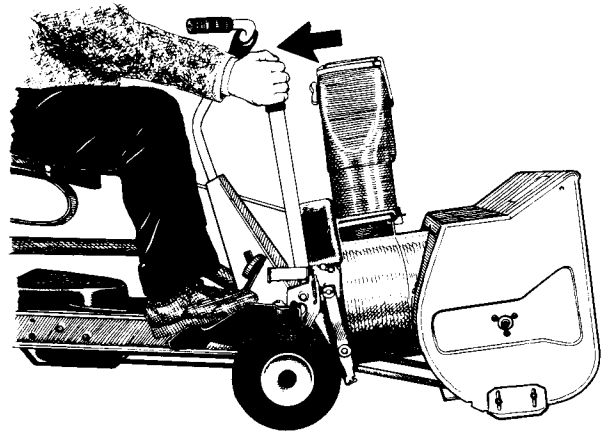

FIGURE 2 - PULL REARWARD TO TRANSPORT

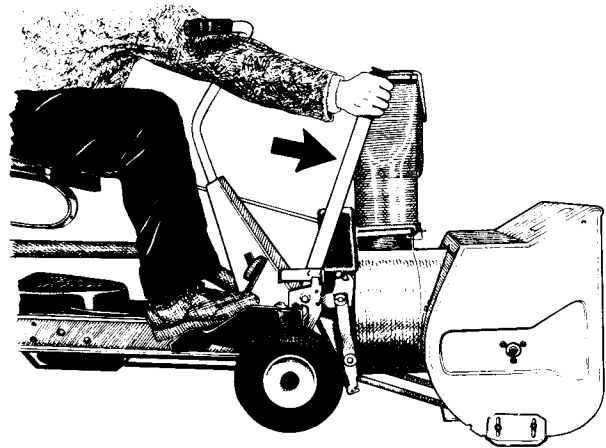

FIGURE 3 - LATCH FORWARD FOR HEAVY SNOW

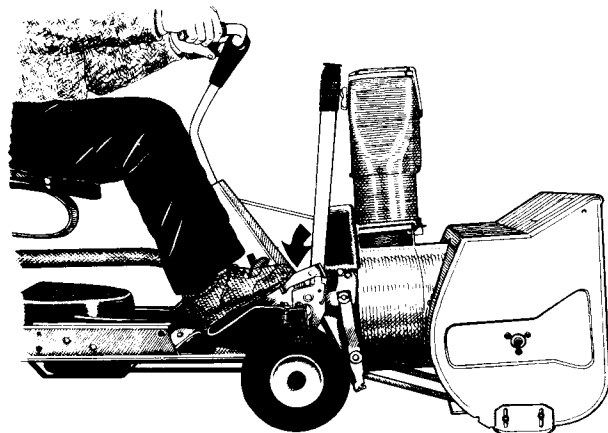

FIGURE 4 - UNLATCH TO FLOAT POSITION

4. To clear snow, move the transmission SHIFT LEVER into #1 speed, release the CLUTCH/BRAKE pedal and move slowly forward into the snow. Set the ground speed higher to suit the snow conditions as you progress.
5. Before proceeding into heavy snow, push the lift lever all the way forward until the latches catch over the forward edges of the side braces. This shifts the blower unit out of float position into solid contact with the surface. Use this position only in extra heavy snow conditions. To shift back to float position in normal conditions, simply depress the rear of the latch lever on the right (Figures 3 and 4).

SERVICES

LUBRICATION SERVICES

Refer to the Engine Manual for lubrication requirements on the engine. The Snow Thrower unit has two grease fittings on the augers and two on the auger shaft bearings as shown in Figure 5. The unit also has a lube checkpoint at the front of the auger-impeller gearbox shown in Figure 6. Service these and the other general lube points as follows:

AUGER LUBRICATION: ONCE EACH YEAR, preferably at the end of the winter season, remove the two shear bolts, apply grease to the fittings then spin the auger to work the grease out along the auger shaft. Continue greasing and spinning augers until grease appears at both ends of each auger tube. Reinstall shear bolts and nuts after servicing. This procedure will prevent the auger shaft from rusting to the auger tube.

BEARING LUBE: ONCE EACH YEAR, apply one or two shots of grease from gun to the bearing grease fittings located at the ends of the auger shaft just inside the blower housings.

GENERAL LUBE POINTS: ONCE EACH YEAR, (or more often if rust formation hampers operation), spread a light coating of grease on the chute crank worm and on the underside of the gear ring at the base of the discharge chute. Also squirt oil from oil can into the gap between the inside of the discharge chute and the outside of the discharge flange of the blower housing. Crank chute back and forth while oiling to spread lubrication evenly over both surfaces.

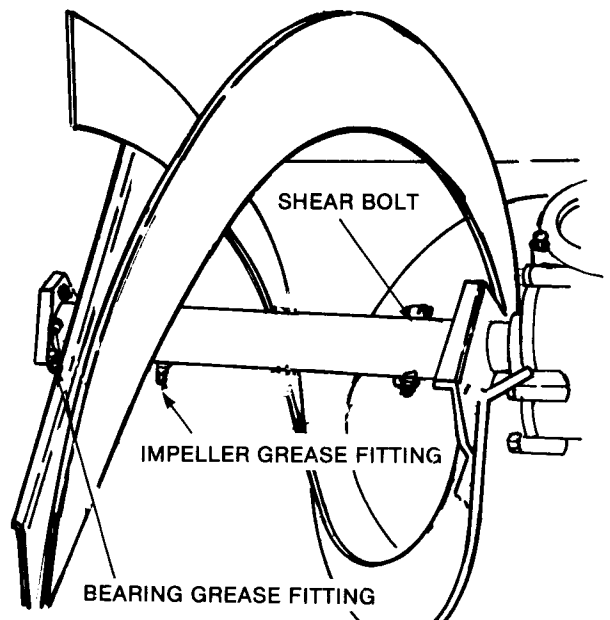

FIGURE 5 - AUGER GREASE FITTINGS

GEARBOX LUBE: AFTER EACH 25 HOURS of operation (or each time the engine oil level is changed) remove the plug at the front of the gearbox and check the oil level. With the Thrower on a flat, level surface, the oil should be even with the lower edge of the check hole. Use an oil can containing the same weight and grade of oil specified for the engine crankcase to bring the level up to the point of overflowing from the hole. Reinstall the oil plug after servicing.

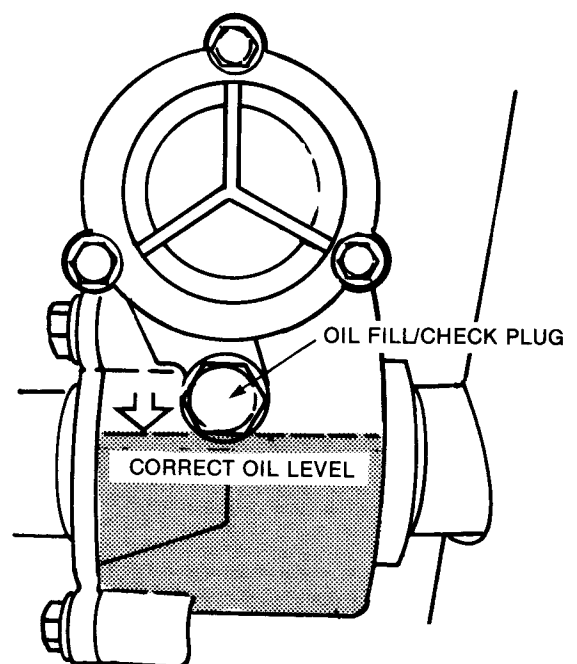

FIGURE 6 - BLOWER GEAR BOX

SEASONAL CHANGE-OVER

At the end of the winter season, convert the Rider back to mower configuration using the following procedure. Tools required for the conversion are a pair of pliers and two each 7/16, 1/2 and 9/16" wrenches. Keep in mind while removing the snow thrower components that the carrier weighs about 70 pounds and the blower unit about 125 pounds.

SNOW THROWER REMOVAL: As the components are detached and removed, reinstall the fasteners wherever possible to keep these handy for installation at the start of the next snow season.

STEP 1: Remove the four bolts securing the spindle cover to the side rails of the carrier unit, turn the cover sideways and lift over the blade lever to remove.

STEP 2: Loosen the engine drive belt idler and slip the engine belt off the carrier pulleys (Figure 7).

STEP 3: Unplug the wiring harness terminals from the carrier interlock switch (Figure 8).

STEP 4: Unhook the blower belt tensioning spring from the right edge of the carrier and slip the belt off the pulley on the underside of the carrier (Figure 9).

STEP 5: Disconnect and remove the carrier unit by lifting the chains off the rear lift hooks and pulling the cotter pin from the end of the front lift support pin and pulling this pin, slide the carrier unit out from under the Rider.

STEP 6: Pull the rear pin out of the universal joint at the chute crank worm gear then slide the crank rod toward the rear out of the bracket. The crank bracket does not have to be removed unless this is so desired.

STEP 7: Use the pliers to unhook the lift assist springs from the top rod of the lift handle assembly (Figure 10).

STEP 8: Place a block of wood under the impeller section of the blower to prevent it from falling when separated then remove the cotter pins and two clevis pins from the support arms (Figure 11).

STEP 9: Disconnect the lift links by pulling the cotter pins and bending the top edges of the links outward and over the posts (Figure 12).

STEP 10: The blower unit can now be pulled away from the Rider. The lift handle assembly does not have to be removed from the Rider unless so desired. Remove this by removing the capscrews securing the braces to the

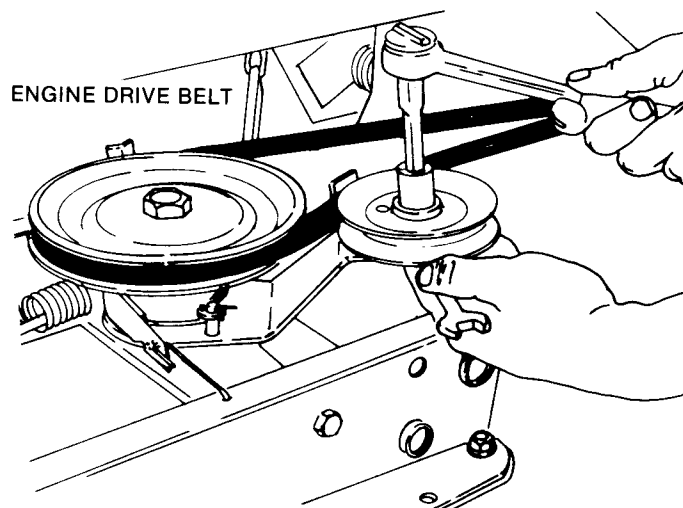

FIGURE 7 - LOOSEN IDLER PULLEY

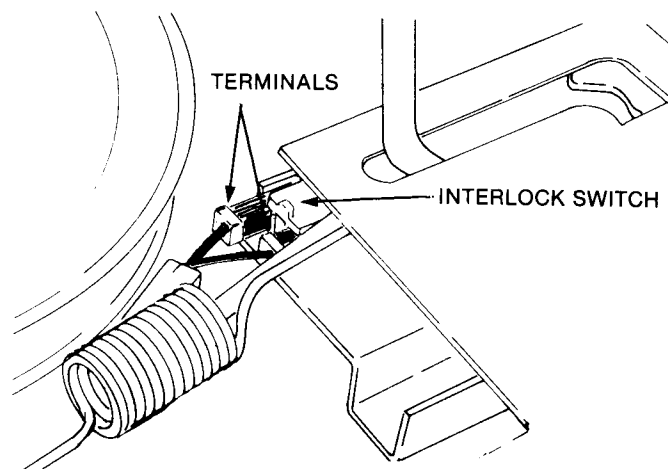

FIGURE 8 - DISCONNECT INTERLOCK

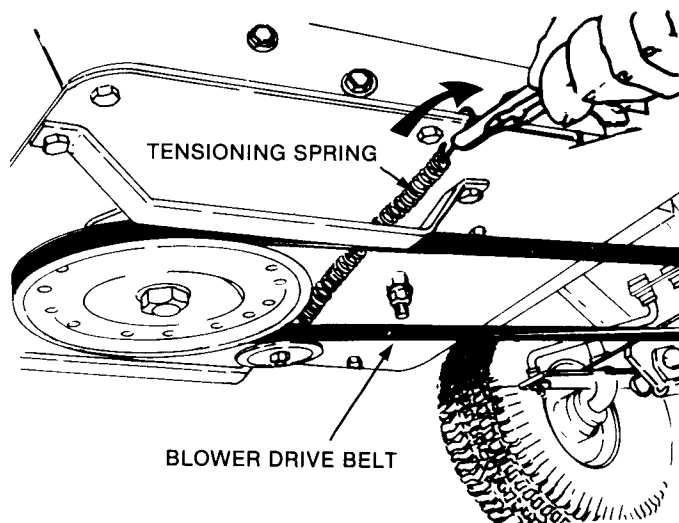

FIGURE 9 - UNHOOK BLOWER BELT SPRING

front end. Service the Blower unit before placing in storage during the off season following instructions on page 5 of this manual.

MOWER INSTALLATION PROCEDURE: After the snow thrower attachment has been removed, install the mower deck to the Rider as follows:

STEP 1: Remove the spindle cover from the mower and slide the unit into position under the Rider.

STEP 2: Lift the front edge of the mower to align holes in the front lift arms with those in the mounting supports on the underside of the front end, insert the support pin and lock with a cotter pin thru the hole in the end.

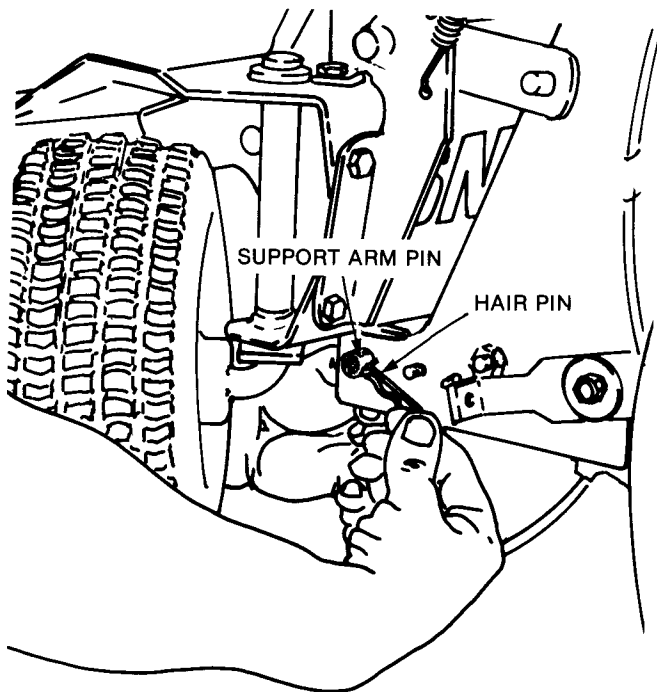

FIGURE 11 - PULL SUPPORT ARM PINS

STEP 3: Hook the chains on the rear lift arms to the chain hooks on the rear end of the Rider. Refer to the instructions on page 7 of the Riding Mower Operator's Manual for details on levelling the mower on your particular model.

STEP 4: Connect the wiring harness terminals to the mower deck interlock.

STEP 5: Loosen the idler pulley and install the engine drive belt then adjust tension as described on page 7 of the Riding Mower Operator's Manual. Install the spindle cover to complete the mower installation procedure.

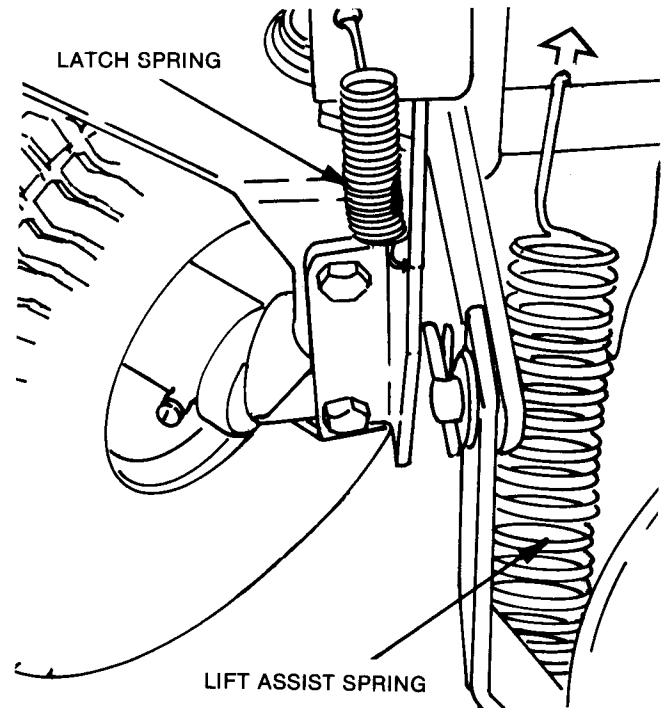

FIGURE 10 - UNHOOK LIFT ASSIST SPRING

NOTE: Refer to the SNAPPER Riding Mower Operator's Manual (#1-2629) for important Safety and operating instructions while using the Rider in the mower configuration. Make sure that the engine oil is changed to the weight and grade specified in the engine owner's manual for summer temperatures before mowing.

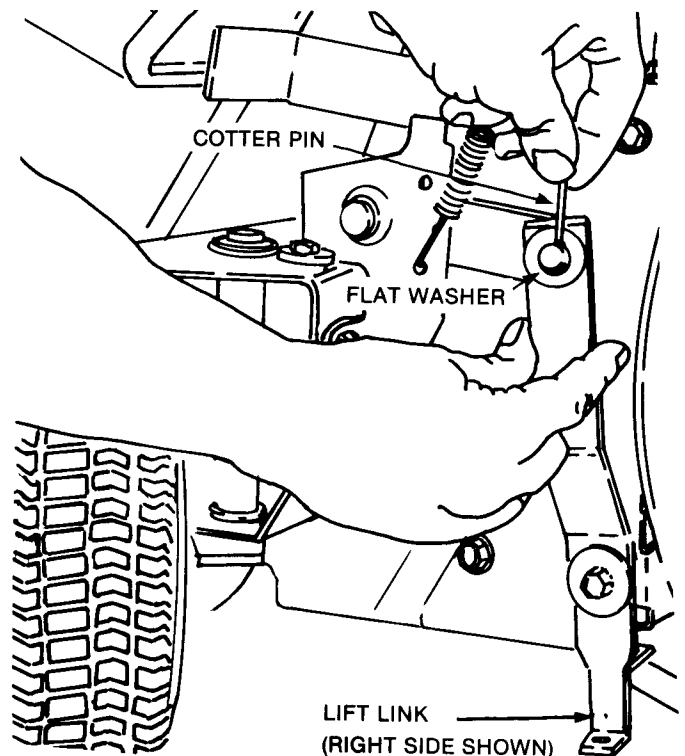

FIGURE 12 - DISCONNECT LIFT LINKS

MANUFACTURER'S 90 DAY LIMITED WARRANTY

For Ninety (90) days from purchase date for a non-commercial user, or for Thirty (30) days from purchase date for a commercial user, McDONOUGH POWER EQUIPMENT, through any factory authorized service dealer, will replace for the original purchaser, free of charge, any part or parts found upon examination by the factory at McDonough, Georgia, to be defective in material or workmanship or both.

All transportation cost incurred by the purchaser in submitting material to an authorized service dealer for replacement under this warranty must be borne by the purchaser.

This warranty does not apply to parts that have been damaged by accident, alteration, abuse, improper lubrication, normal wear, or other cause beyond our control.

There is no other express warranty.

Implied warranties, including those of merchantability and fitness for a particular purpose, are limited to ninety (90) days from purchase for non-commercial users, and for thirty (30) days from purchase for commercial users and to the extent permitted by law any and all implied warranties are excluded. This is the exclusive remedy. Liabilities for consequential damages under any and all warranties are excluded.

Some states do not allow limitations on how long an implied warranty lasts or do not allow the exclusion or limitation of incidental or consequential damages, so the above limitation or exclusion may not apply to you.

This warranty gives you specific legal rights, and you may also have other rights which vary from state to state.

McDONOUGH POWER EQUIPMENT, McDONOUGH, GEORGIA 30253

ACCESSORIES

For added performance and traction, wheel weight, tire chain and drift cutter kits are available from your Snapper Dealer. A brief description of these kits and their function is as follows.

WHEEL WEIGHT KIT #1-4242: Includes two weights which fit inside the rims of the rear wheels to add approximately forty pounds for improved traction.

TIRE CHAIN KITS: Order kit #6-0357 for wide tires or #6-0358 for narrow 4.80-4.00 x 8" rear tires.

DRIFT CUTTER KIT #6-0472: Cutter bar easily installs on side of blower housing and extends above housing to slice into high banks and knock the snow down into the path of the collector.

Other SNAPPER Products

SNAPPER tillers can be converted to walking tractors so you can also plow or cultivate.

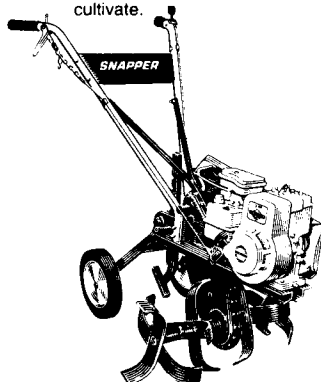

19" and 21" SNAPPER walk mowers are superior bagging mowers which can be converted to mulching mowers and leaf shredders.

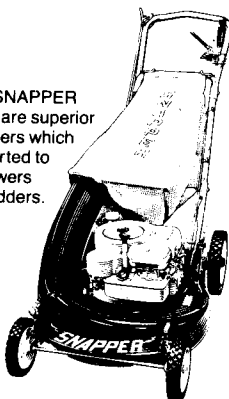

SNAPPER tractors with hydrostatic transmissions have a single pedal that controls both your speed and direction. Great for maneuvering on the lawn or in the garden.

Shown with optional cutting unit. 42", 48" and 54" units available.

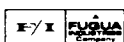
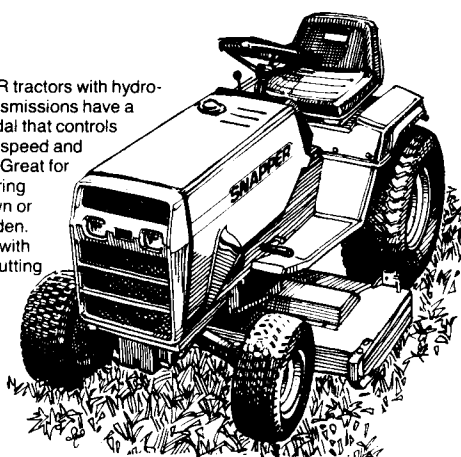

McDonough Power Equipment McDonough, GA • 30253

SNAPPER 

#6-0514 EXTENDER KIT FOR SNOW THROWER ATTACHMENT ON 33" AND 42" SNAPPER RIDERS

Since wider front ends are used on the 33 and 42" models, width extenders must be installed on the sides of the blower to keep the front wheels tracking inside the path of the cleared snow.

In addition, the 33" models have extended main tubes which require a longer belt and installation of extender braces on the underside of the front end for proper positioning of the carrier assembly.

Before installing components of the 82099 Snow Thrower Attachment Kit on 33 and 42" models, install components from this extender kit as follows:

WIDTH EXTENDERS - 33 and 42" MODELS

STEP 1: Remove the skid shoes from both sides and save these items and the fasteners.

STEP 2: Assemble the left side brace to the outside of the left width extender as shown in Figure 1 and secure with one of the carriage bolts removed in Step 1 and with a 5/16 split lockwasher (Item 6) and 5/16 hex nut (Item 5) from kit. Repeat this procedure to assemble the right side brace and extender.

STEP 3: Move the left side brace/extender assembly into position on the blower, secure at the two upper points with the 5/16-18 x 3/4 hex head capscrews (Item 4) inserted from the inside and with 5/16 split lockwashers (Item 6) and 5/16 hex nuts (Item 5) on outside of blower.

STEP 4: Place the skid shoe between the blower housing and side brace, align holes and insert two 5/16-18 x 1" carriage bolts (Item 3) from inside and secure on outside of brace with the hex flange nuts removed in Step 1.

STEP 5: Note the two holes drilled thru the width extender but not thru the blower housing. Using the extender holes as the guide, drill thru the blower housing at these two points with a 11/32" drill bit. Secure with two 5/16 x 3/4 capscrews (Item 4) inserted from the inside and with two 5/16 split lockwashers (Item 6) and 5/16 hex nuts (Item 5) on outside of blower.

STEP 6: Repeat procedure called for in Steps 3, 4 and 5 to install the brace extender components on the right side.

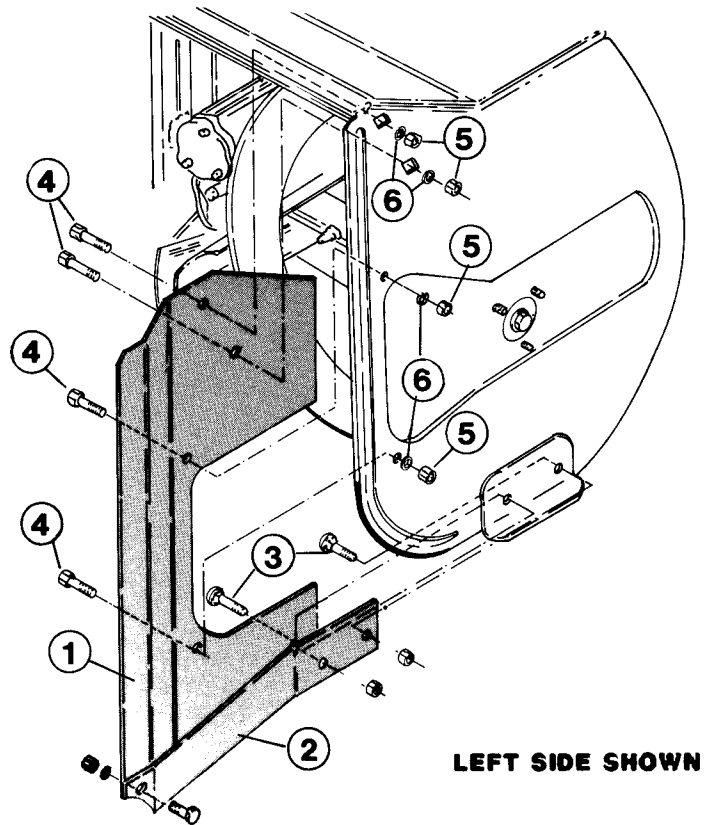

FIGURE -1 WIDTH EXTENDER COMPONENTS

KITS PARTS LISTING

ITEM	PART NO.	DESCRIPTION	QTY.
1	3-9999	EXTENDER, RIGHT SIDE	1
-	3-5000	EXTENDER, LEFT SIDE	1
2	3-8022	BRACE, RIGHT SIDE	1
-	3-8023	BRACE, LEFT SIDE	1
3	9-0208	CARRIAGE BOLT, 5/16 x 1"	4
4	9-0206	CAPSCREW, 5/16 x 3/4 HEX HD.	8
5	9-0196	NUT, 5/16-18 HEX	10
6	9-0187	LOCKWASHER, 5/16 SPLIT	10
* 7	3-2212	EXTENDER, SUPPORT	2
* 8	1-4240	BELT (NOT SHOWN - FOR 33")	1
* 9	9-0536	BOLT, 5/8 x 1-1/4	4
*10	9-0537	NUT, 5/8-11 HEX	4
*11	9-0333	LOCKWASHER, 5/8 SPLIT	4
*12	9-0183	WASHER, 5/8 FLAT	4

*ITEMS 7-12 SHOWN ON FIGURE 3, PAGE 2

SUPPORT EXTENDERS - 33" MODELS ONLY

After the cutter deck has been removed, stand the Rider on its rear bumpers and install the extenders shown in Figure 3 as follows:

STEP 1: Position the support extenders (Item 7) on the inside of the support braces on the underside of the front end.

STEP 2: Insert two 5/8 x 1-1/4 bolts (Item 9) in each extender as shown in Figure 3 then install flat washers (Item 12), split lockwashers (Item 11) and 5/8 hex nuts (Item 10) and securely tighten these. When installing the snow thrower carrier assembly from Kit #82009, insert the support pin thru the rear holes in these support extenders.

STEP 3: Because of the extended tube on the 33" models, use the belt (Item 8) provided in the kit in place of the carrier to blower drive belt furnished in Kit #82099.

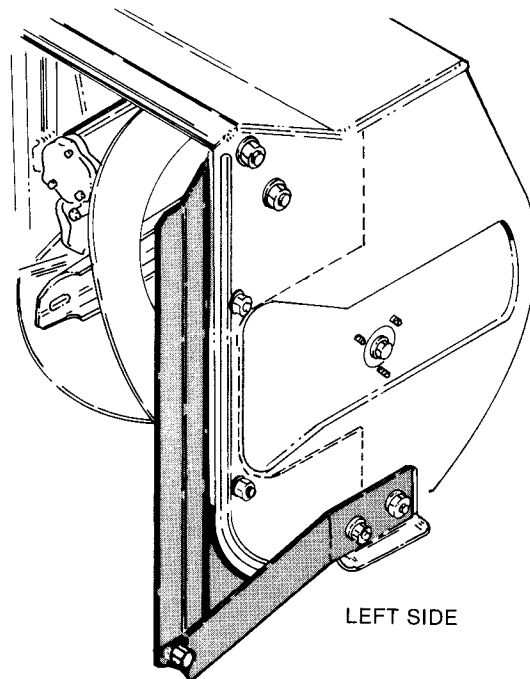

FIGURE -2 WIDTH EXTENDER INSTALLED

SEE PARTS LIST ON PAGE 1

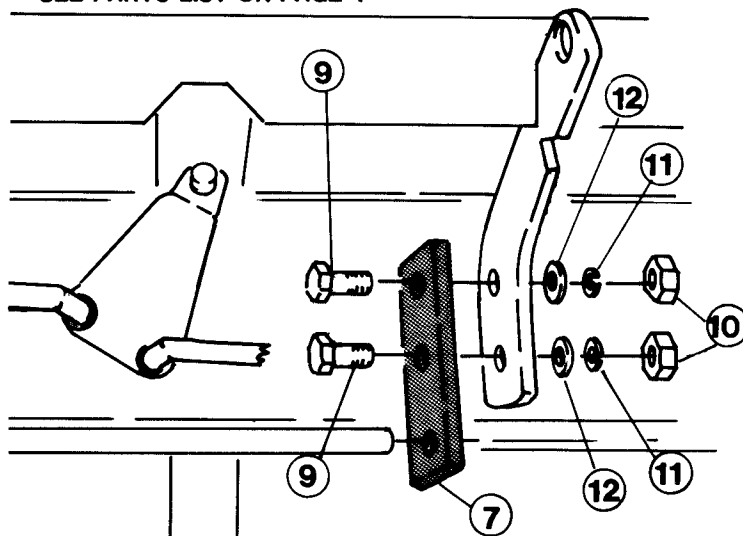

FIGURE -3 SUPPORT EXTENDER FOR 33"

42" ENGINE DRIVE DISC AND BELT REPLACEMENT NOTE

To attain snow throwing capabilities on 42" models, the 6" O.D. drive disc assembly and engine belt furnished on these models should be removed and replaced by a smaller diameter 4" O.D. (5-0169) drive disc assembly and 1-0749 engine belt. The 6" O.D. disc and engine belt will have to be reinstalled at the end of the winter season when converting back to the mower.

McDonough Power Equipment
McDonough, GA • 30253



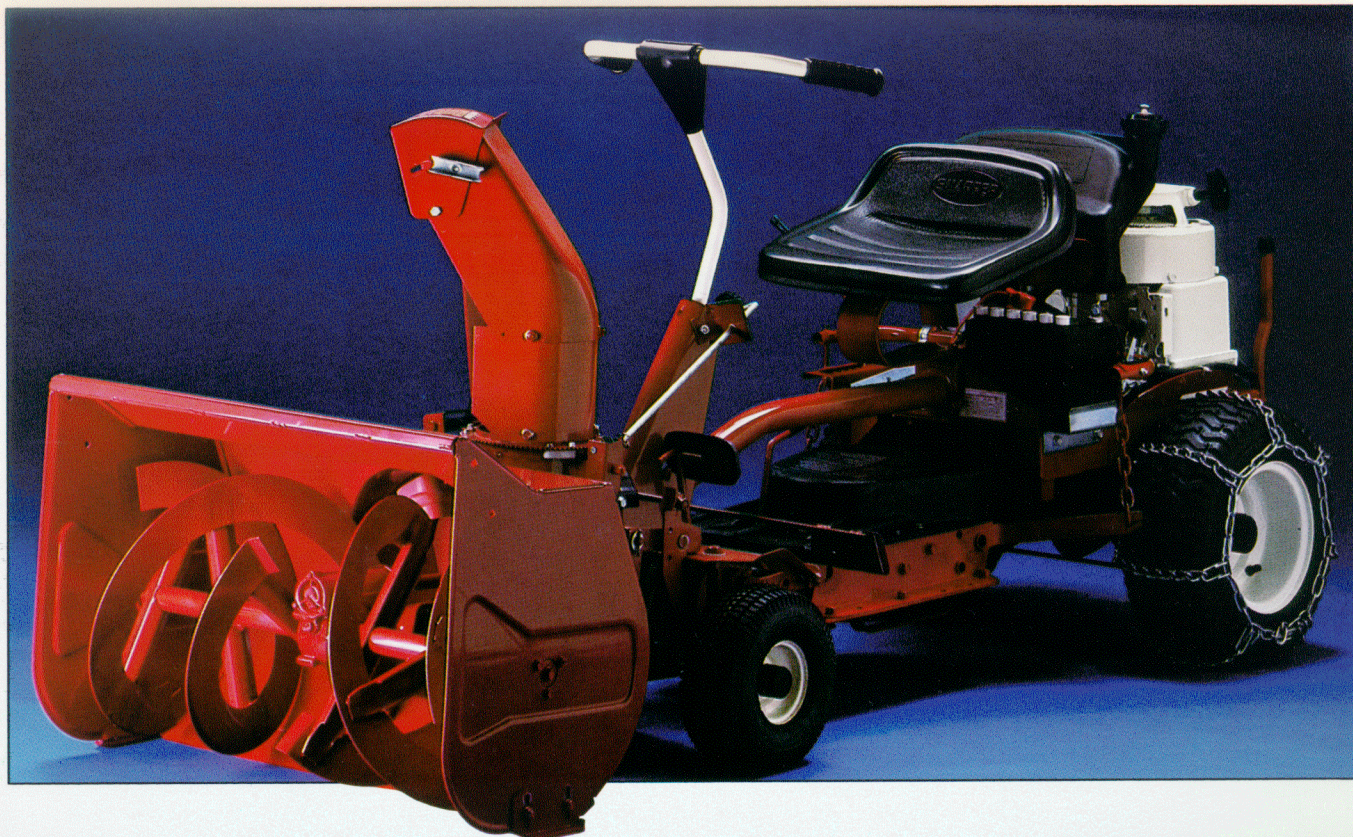

SNAPPER RIDERS NOW HAVE FOUR SEASON VERSATILITY

The new season is winter, and the Snapper rider, known for its strong drive that operates when the going gets tough, now has a front-mounted two-stage snowthrower attachment. It will help you handle deep snowfall, heavy slush, and

ice-encrusted snowbanks.

The new attachment is two-stage in design. In the **First Stage** of operation, powerful auger blades, driven by a bronze drive



gear, move snow to the **Second Stage** where it is forcefully discharged by a 12 inch impeller with four blades. The discharge chute is rotated from the operator's position as the direction crank is turned. A strong worm gear assembly effortlessly rotates the chute 180° in all conditions.

The snowthrower attaches easily, just replace the cutting unit with the carrier and attach the snowthrower with 2 pins. All 8 and 11 H.P. SNAPPER rear engine riders accept the 30 inch snowthrower model. For wide front end model Snapper riders, there is a width extension kit that attaches to each side of the snowthrower unit for extra clearing. The SNAPPER rider and snowthrower attachment, truly a versatile unit to help you get through those tough winters.

SPECIFICATIONS

Augers	15" dia. with shear pin protection
Clearing widths	30"—34"
Discharge chute rotation	180°
Hardened skid shoes	Adjustable and reversible
Impeller	12" dia. with 4 blades
Overall height	42"
Overall width	30"—34"
Scraper blade	Adjustable
Sealed gear case	Steel worm & bronze worm gear
Shipping weight	215 lbs.
Snowthrower clutch control	Mechanical deadman
Optional accessories	Drift cutter bars
	Wheel weights
	Tire chains



McDonough Power Equipment McDonough, GA • 30253



82099 SNOWTHROWER MODIFICATION

When the belt stretches the spring loaded idler takes up the slack pulling the belt out of alignment with the mule drive pulley causing it to come off. SEE ORIGINAL BOTTOM VIEW SHOWN ON LEFT.

Stand Rider and Snowthrower on end. Use a 11029 idler pulley and fit onto belt as shown (1) and push belt outward until belt is aligned with front pulley. (2) Then mark the spindle mounting plate at the center of the pulley and drill a 5/16" hole.

Then in the side view insert a 5/16 bolt (length unknown) (3) through the frame, stack washers or make a spacer (4) to position the new pulley to (5) hold the belt straight, then add a 5/16 washer (6) and 5/16 lock nut (7). JR

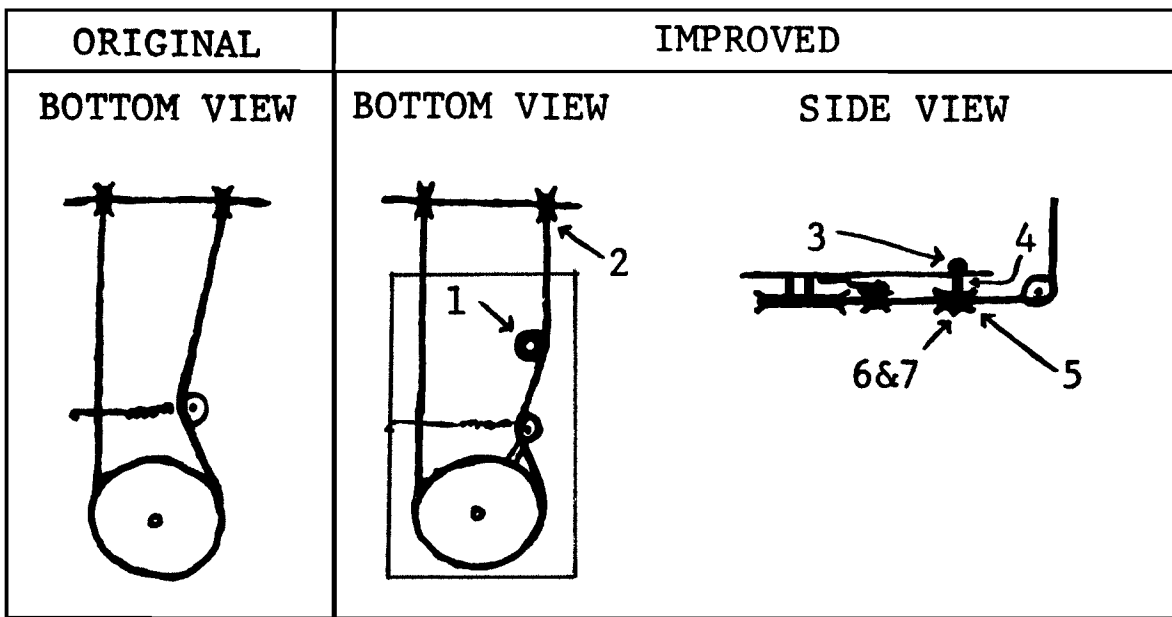

Free Manuals Download Website

<http://myh66.com>

<http://usermanuals.us>

<http://www.somanuals.com>

<http://www.4manuals.cc>

<http://www.manual-lib.com>

<http://www.404manual.com>

<http://www.luxmanual.com>

<http://aubethermostatmanual.com>

Golf course search by state

<http://golfingnear.com>

Email search by domain

<http://emailbydomain.com>

Auto manuals search

<http://auto.somanuals.com>

TV manuals search

<http://tv.somanuals.com>