

Safety Instruction & Operator's Manual for

# **SNAPPER**<sup>®</sup>

## **TOTAL PROTECTION**

### **IRT4 SERIES 2 TILLER**

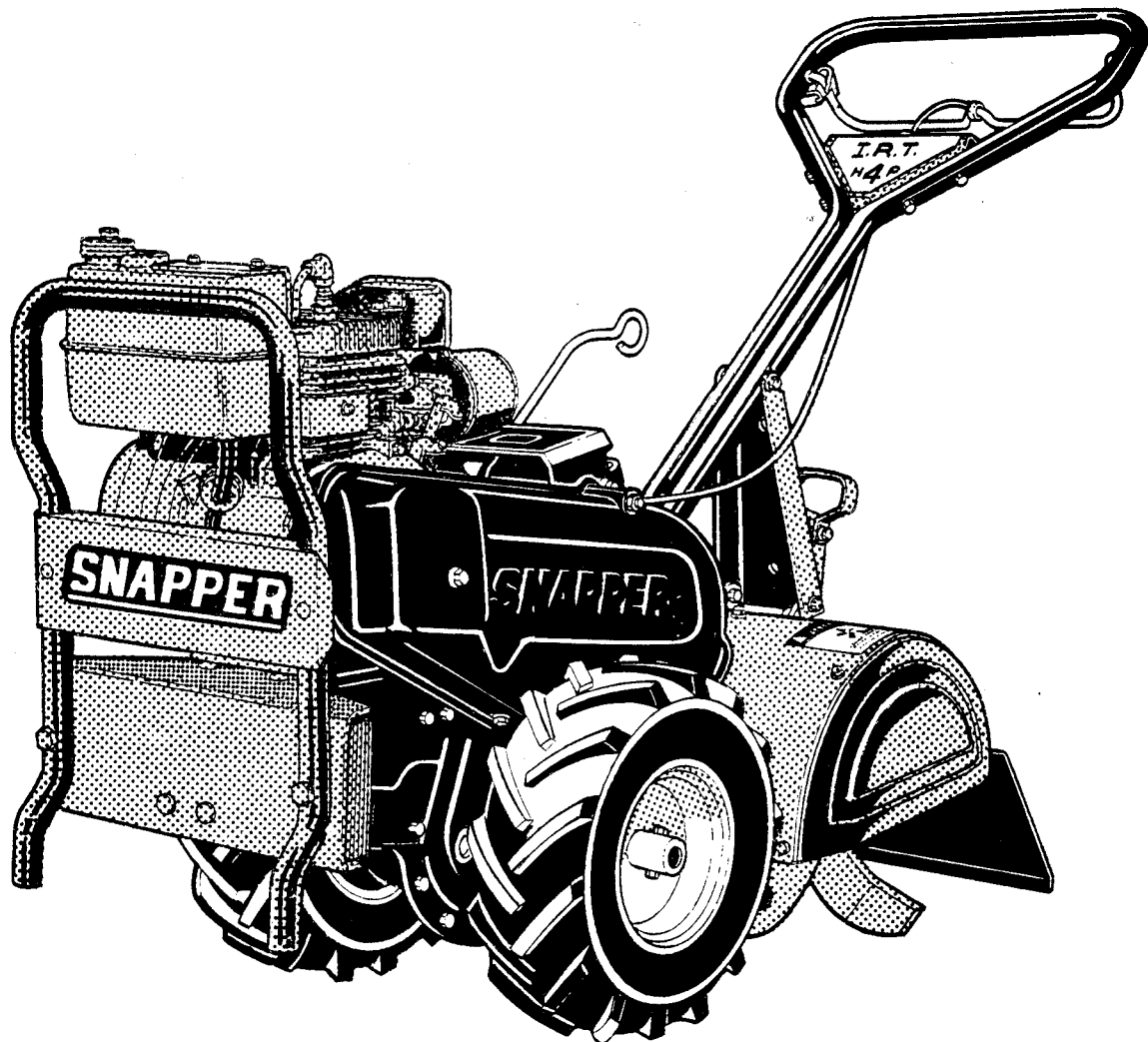

Thank you for buying a **SNAPPER** product! Your Tiller was designed and built to provide long and satisfactory service. Study this manual carefully before operating the Tiller and pay particular attention to the Important Safety Instructions found herein. Keep in mind that a Tiller, like any other mechanical device, can be potentially dangerous if used improperly. Following the instructions in this and the engine manual will help you continue to enjoy the trouble-free operation expected of a **SNAPPER**.

# IMPORTANT SAFETY INSTRUCTIONS

Warning: This tilling machine is capable of causing personal injury! Failure to observe the following instructions could result in serious injury to the operator or persons in the operational area. Carefully read these instructions and be sure to question your **SNAPPER** Dealer if in doubt about anything. Should the Dealer not answer to your satisfaction, write or call the **SNAPPER** Customer Service Department at McDonough, GA., 30253 (Phone 404-957-9141).

1. Become thoroughly familiar with all controls and learn how to stop tine rotation quickly in preparation for emergencies.
2. Never allow children or immature, uncoordinated or inexperienced persons to operate your tiller.
3. Keep everyone safely away from the area being tilled.
4. Be especially watchful for children and pets darting into the area while operating.
5. Wear protective clothing and appropriate shoes to provide best footing on uneven terrain.
6. Persons under the influence of alcohol or drugs must not be allowed to operate your tiller.
7. Stay alert, give complete and undivided attention to the job on hand.
8. Fill fuel tank only when engine is stopped and not hot. Fill outside where fumes can be safely dissipated.
9. Make sure clutch is disengaged before attempting to start.
10. Keep feet, hands and clothing safely away from tines at all times.
11. Disengage the tines and stop the engine before making any adjustments, attempting to clean or clear tines, or leaving the operator's position even momentarily!
12. Remember to avoid operating the engine in any enclosed area where deadly exhaust fumes could accumulate.

# IRT4 SERIES 2 REAR TINE TILLER

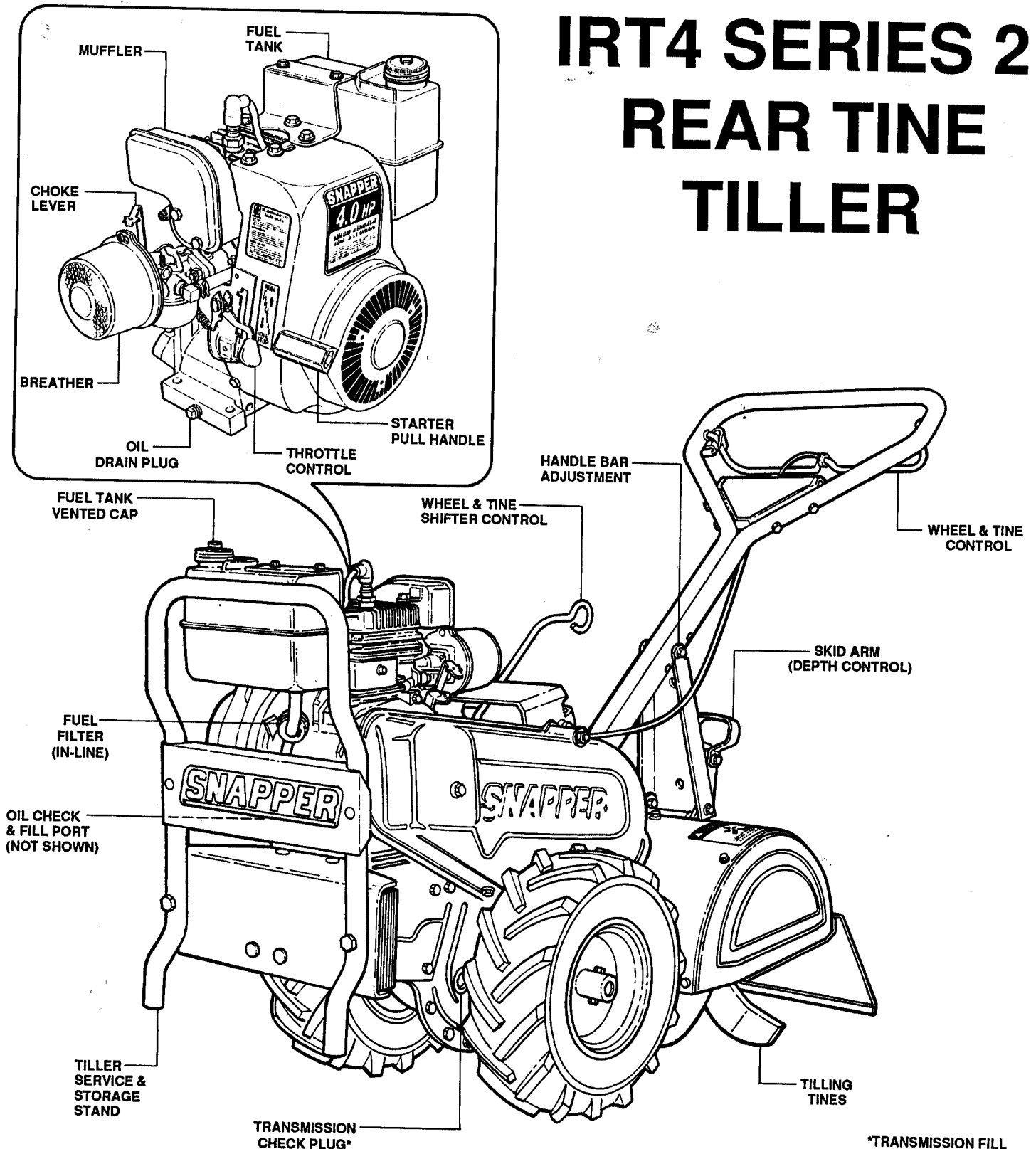

FIGURE 1

\*TRANSMISSION FILL PLUG NOT SHOWN. REFER TO FIGURE 9.

**INTRODUCTION:** This manual covers the recommended operating procedure and routine service requirements on SNAPPER IRT4 Series 2 Rear Tine Tillers. It is recommended that all operators of this tiller become thoroughly familiar with the controls and proper operation of the unit before operating. Specific details involving the engine are found in the separate engine owner's manual. Study these manuals before operating and keep both handy for future reference. Refer to Figure 1 above for location of controls and other essential components on the IRT4.

# OPERATING INSTRUCTIONS

## BEFORE OPERATING:

Be thoroughly familiar with all controls and how to use them before operating your tiller. Make the following checks and perform the services as required before each startup.

## PRE-START CHECK LIST

**CHECK ENGINE OIL** and bring level up to full. (Refer to engine manual for oil specifications).

**CHECK AIR CLEANER** and replace paper filter once a year or every 100 operating hours. More often if used in extremely dusty conditions. Refer to Figure 13.

**CHECK GUARDS** to make sure all are in proper position and securely tightened.

**FILL FUEL TANK** where fumes will be safely dissipated. Refer to Engine Manual for specifications.

**CHECK FUEL TANK VENT** to make sure it is open.

## STARTING - STOPPING

Know beforehand how to stop the tines, wheel drive and engine in preparation for possible emergencies. The engine is stopped by pulling the engine THROTTLE CONTROL "DOWN" to STOP. See Figure 2.

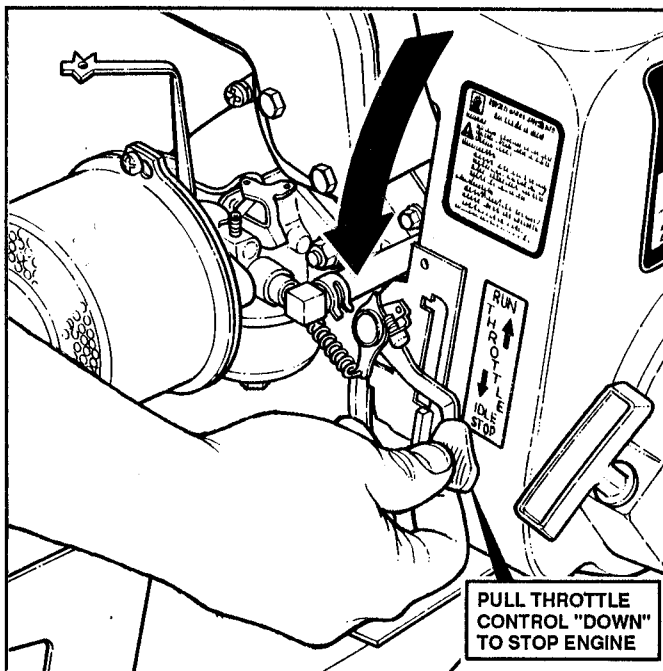

FIGURE 2

Tine rotation is stopped by releasing the WHEEL & TINE CONTROL which stops the driven wheels and tine rotation, even with the TINE CLUTCH in engaged position. See Figure 3.



FIGURE 3

## OPERATE ENGINE AS FOLLOWS:

**STEP 1:** Shift the transmission into NEUTRAL and make sure WHEEL & TINE CONTROL is in released position. See Figure 4.

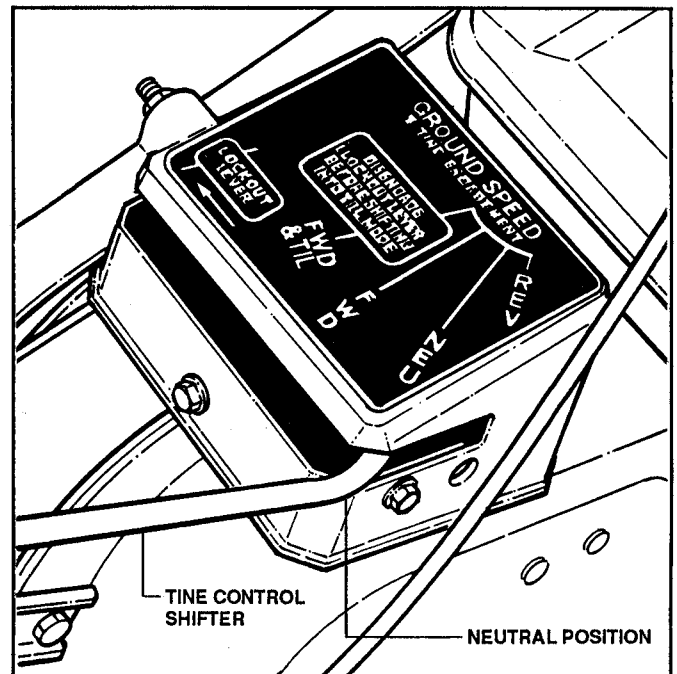

FIGURE 4

**STEP 2:** On cold starts, move the CHOKE CONTROL on the engine to CHOKE position. See Figure 5.

# OPERATING INSTRUCTIONS

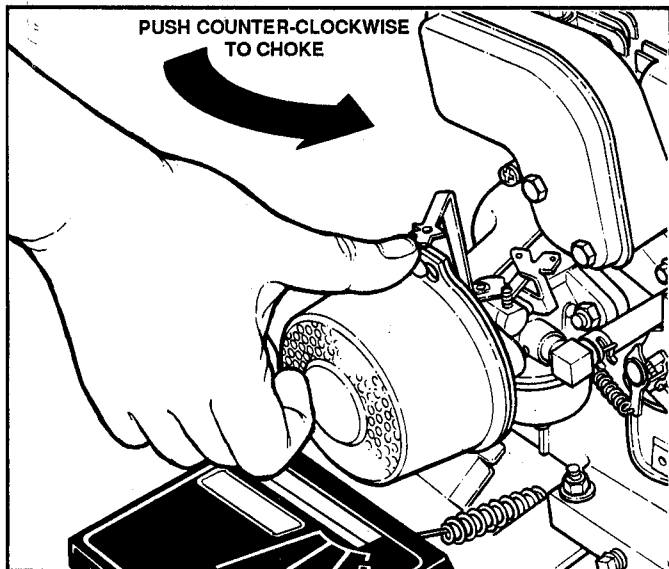

FIGURE 5

**STEP 3:** Move THROTTLE CONTROL to the RUN position.

**STEP 4:** Move around to right side of unit and place foot on top of right wheel, hold handle bar (see starting procedure decal), and pull ROPE STARTER on engine in smooth, steady motion until engine starts. To prolong the life of the rope, guide the starter handle back to the engine rather than allowing it to snap back.

**STEP 5:** Allow brief engine warm-up period, move choke lever to RUN position and move the engine THROTTLE CONTROL "UP" to the desired speed setting. Refer to TILLING PROCEDURE section in next column.

**STEP 6:** To stop the engine, pull the engine THROTTLE CONTROL "DOWN" to STOP.

## HANDLE BAR ADJUSTMENT

Remove retaining screw and nut from handle bar support. Adjust handle bar "UP" or "DOWN" as required. Reinstall screw and nut. See Figure 6. Additional adjustment can be obtained by repositioning the lower end of the handle bar into one of three holes in the transmission case.

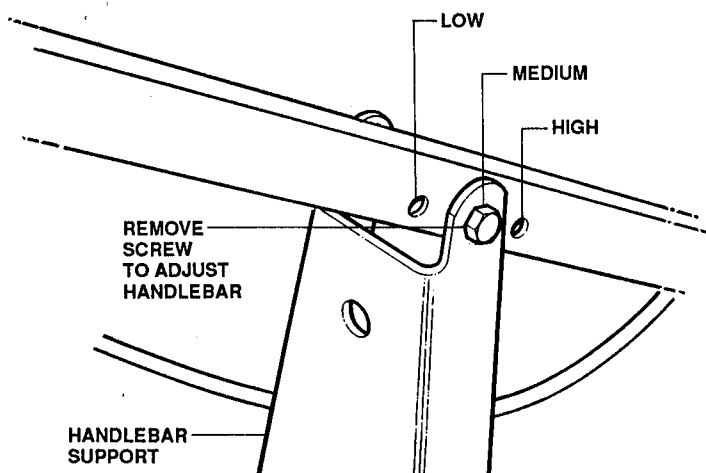

FIGURE 6

## TRANSPORTING TO SITE

To avoid gouging the lawn or pavement, raise the tines to clear the surface before transporting the unit to the tilling site. Release the WHEEL & TINE CONTROL and lift the rear of the tiller to take the weight off the skid arm, then push it downward into the notch setting which will allow the tines to clear the surface. Shift the TINE CLUTCH lever to NEUTRAL. Start the engine, pull the WHEEL & TINE CONTROL back to the handle bar to engage the wheel drive and transport to the tilling site. The tiller can also be shifted into NEUTRAL and pushed to the site. See Figure 7.

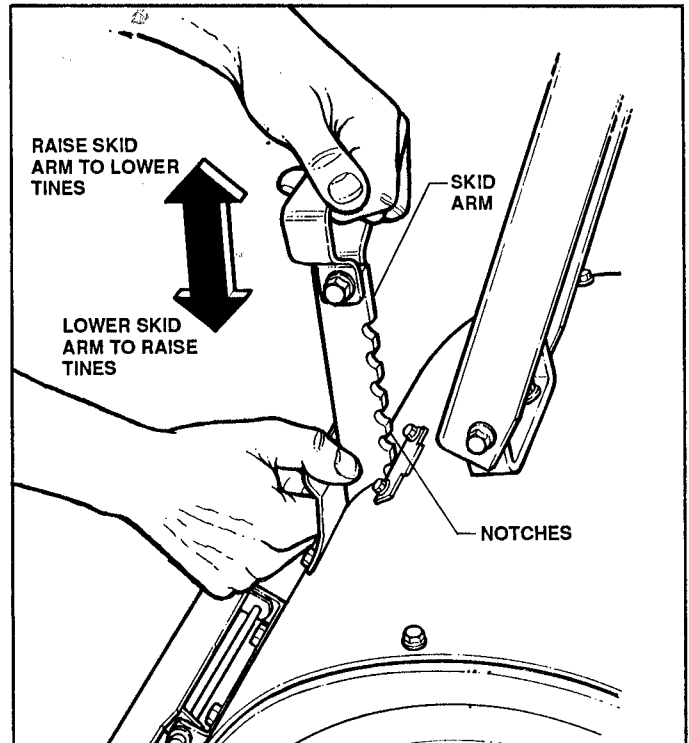

FIGURE 7

## TILLING PROCEDURE

The IRT4 TILLER is set up for reverse tine rotation only. Shifting the transmission lever to REVERSE will disengage the tines while the tiller is moving backwards.

1. **SET HANDLE BAR** in desired position before engaging CLUTCH CONTROL.
2. **SET SKID ARM** in highest position for deepest tilling depth and intermediate notches for lesser depth.
3. **SET SPEED** by moving THROTTLE CONTROL to desired speed setting.
4. **BEGIN TILLING** by shifting TRANSMISSION LEVER to FWD/TILL position. Step behind tiller and lift "UP" on WHEEL & TINE CONTROL to start tilling. See Figure 8.
5. **TILLING HINTS:** Let the tiller do the work! Do not try to hold it back. If forward motion of the unit ceases while tilling deep, lift "UP" slightly on the handle bar to resume forward motion.

# OPERATING INSTRUCTIONS/SERVICE

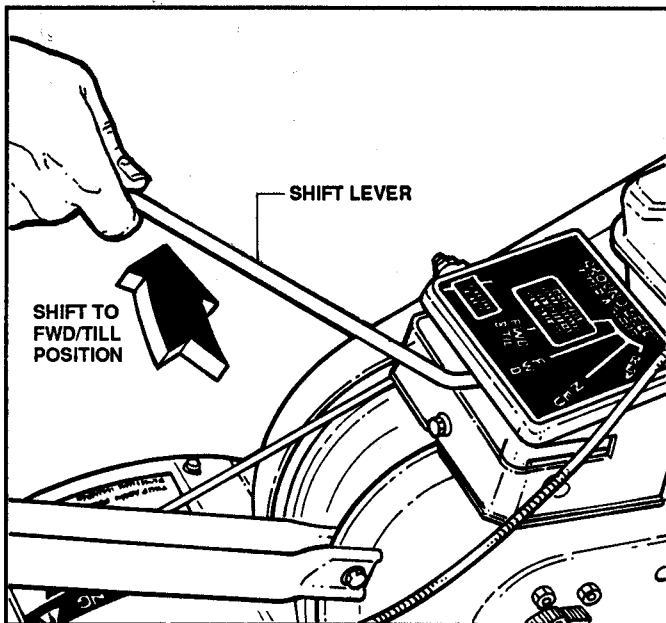

FIGURE 8

6. **ROUGH TERRAIN HINT:** If tilling over very rough, uneven ground, till at light depth setting on the first path to smooth the surface. On especially rough terrain, the tiller could hang up underneath with the wheels spinning free. Under this condition, lift the handle bar, then turn the tiller diagonally across the rise to gain traction.

## SERVICE PARTS & ASSISTANCE

To retain the original quality of your Tiller, use only genuine **SNAPPER** replacement parts. Specify the model and serial number as found on the nameplate of your Tiller when contacting your **SNAPPER** Dealer for parts or service assistance. Only numbers of certain routine service parts are listed in this manual. Your **SNAPPER** Dealer has a complete listing of all components. For engine parts, look for the engine manufacturer's dealers under the heading **ENGINES** - gasoline in the yellow pages of your telephone directory. **SNAPPER** Dealers are listed under **LAWN MOWERS**.

## STANDING TILLER ON END

**CAUTION:** If the fuel tank is over one-half full when the tiller is placed on end, gasoline may leak from the carburetor vent hole and drip down the outside of the engine causing a potential fire hazard! Gasoline may also leak unnoticed into the engine cylinder causing engine damage.

Take the necessary steps to prevent fuel leakage before standing tiller on end. Any draining or transfer of fuel must be done outside with the engine cool and away from ignition sources. If the tiller is stored on end for any length of time, check for oil leakage.

## WARNING!

**NEVER STAND THE TILLER ON END WITH THE ENGINE RUNNING!**

Stop the engine and disconnect the spark plug wire to prevent accidental starting before standing on end.

**SERVICE NOTE:** Since a tiller normally operates under extremely dusty or dirty conditions, the air cleaner, engine oil and cooling fins must be serviced as specified in the engine manual at frequent intervals. The tiller itself should be serviced as follows:

**ENGINE SERVICE:** Refer to the engine owner's manual for details. Engine oil is drained by removing front filler plug and standing tiller on end.

## TILLER LUBRICATION

**CHAIN CASE:** Check the level of the grease in the chain case at the beginning of each tilling season. Check by removing the plastic plug located beside the axle shaft on the lower left hand side. The level should be up to the edge of the opening. To add grease, remove the filler plug located just forward of the pulley shaft on the R.H. side. Add **SNAPPER** Transmission grease as needed to bring level up to bottom edge of the check plug opening. The total capacity of the case is about 1 U.S. Standard quart - do not exceed this amount. Reinstall plugs after checking. See Figure 9.

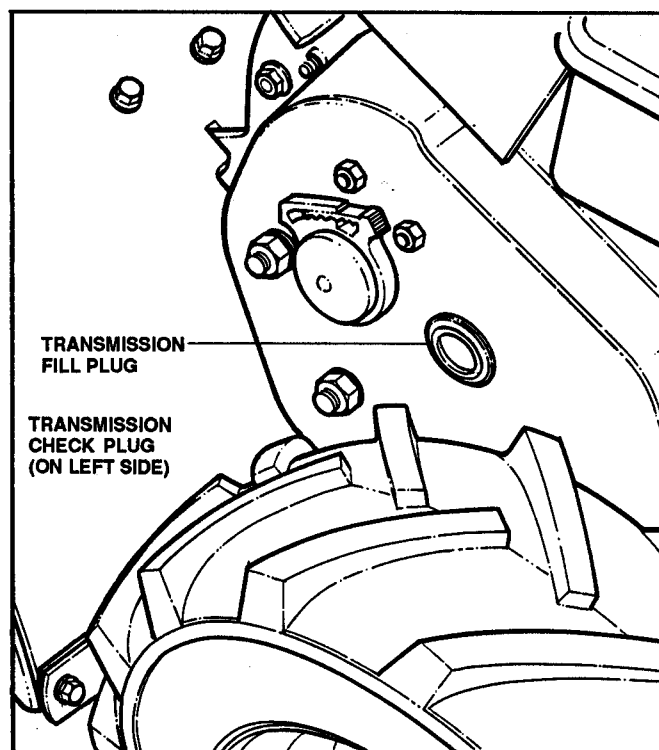

FIGURE 9

# SERVICE

## TILLER TINES

**TINE SERVICE:** The **SNAPPER IRT4 Series 2 TILLER** has R.H. and L.H. tines. Check both tines periodically for loose or missing fasteners. Replace the assembly when blades are badly worn or damaged. Use **SNAPPER #4-9735 R.H.** and **#4-9734 L.H.** tines with **#1-5676** shear bolts and **#9-0222** locknuts for replacement purposes.

The tines are bolted securely to the tine shaft with a special shear bolt (**SNAPPER #1-5676**) and locknut (**#9-0222**) on each side. Keep spares on hand in case a bolt shears off or becomes lost while tilling. See Figure 10. **NOTE:** Do not over-tighten shear bolts as this will cause failure. Tighten 5 to 8 foot pounds of torque maximum!

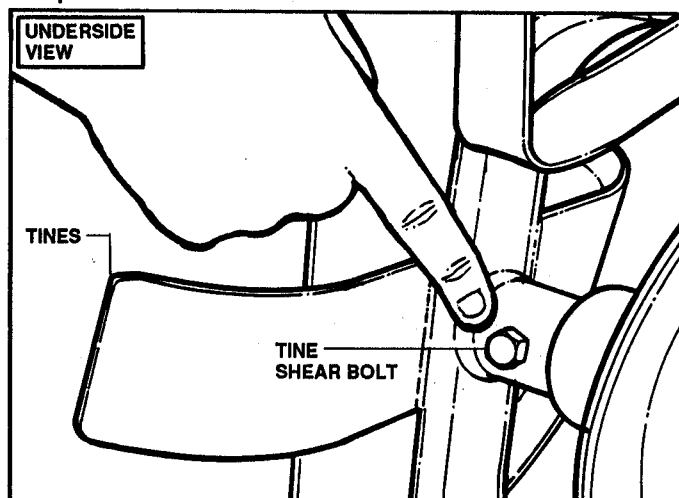

FIGURE 10

## BELT ADJUSTMENT - REPLACEMENT

**BELT TENSION ADJUSTMENT:** To check, remove L.H. wheel and drive belt guard. Measure the length of the **IDLER PULLEY SPRING** at the end of the control cable. Move the **WHEEL & TINE CONTROL** up to the handle bar and measure the extended length of the spring. When properly adjusted, the spring should extend 1/4" to 1/2" when **WHEEL & TINE CONTROL** is engaged. If adjustment is required, loosen and reposition the jam-nuts on the threaded ends of the cable conduits. To increase spring extension, turn the jam-nuts closer to the cable fittings. See Figure 11.

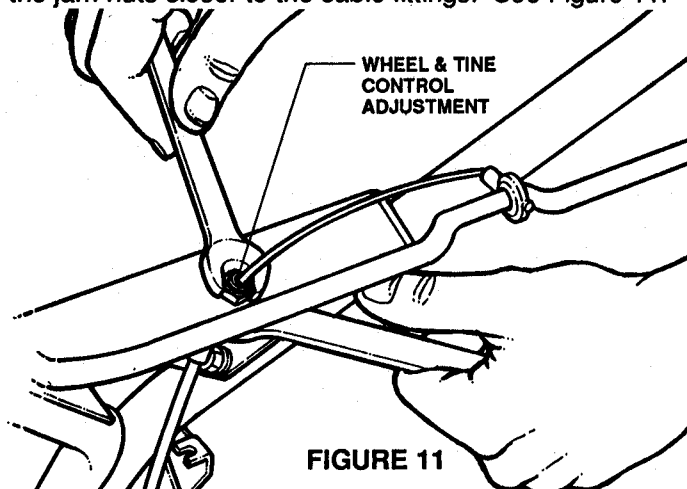

FIGURE 11

**BELT ADJUSTMENT TEST:** Start engine and pull **WHEEL & TINE CONTROL** to handle bar, then release and observe tines and wheel drive which should stop. If tines or wheels continue after **WHEEL & TINE CONTROL** is released, the clutch spring extension is too great. Readjust using the foregoing procedure.

## BELT REPLACEMENT

1. Remove the left hand wheel.
2. Remove two (2) 1/2" screws and nuts from guard.
3. Remove guard.
4. Remove old belt and replace with new belt. Belt must be **OVER TOP** of **IDLER** and within **BELT GUIDE** for proper installation. See Figure 12.

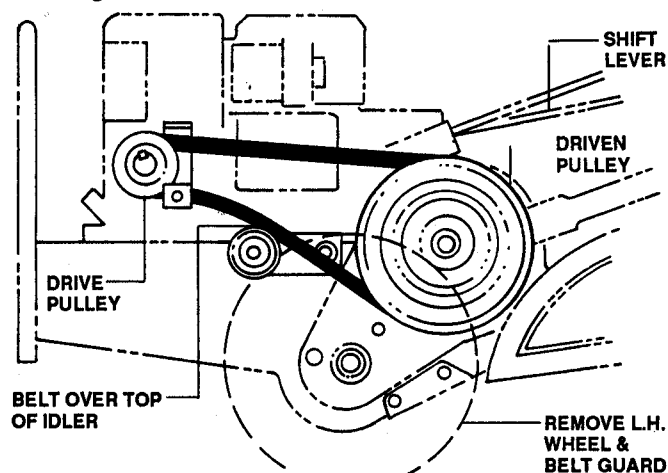

FIGURE 12

## AIR CLEANER - REPLACEMENT

### CAUTION!

**NEVER RUN ENGINE WITHOUT COMPLETE AIR CLEANER INSTALLED ON ENGINE!**

1. Loosen two (2) cover screws. (These need not be removed completely).
2. Rotate cover slightly and remove it from base. See Figure 13.
3. Replace paper filter with new filter as shown in Figure 13. (Replacement filters are available at any Authorized Service Center.)

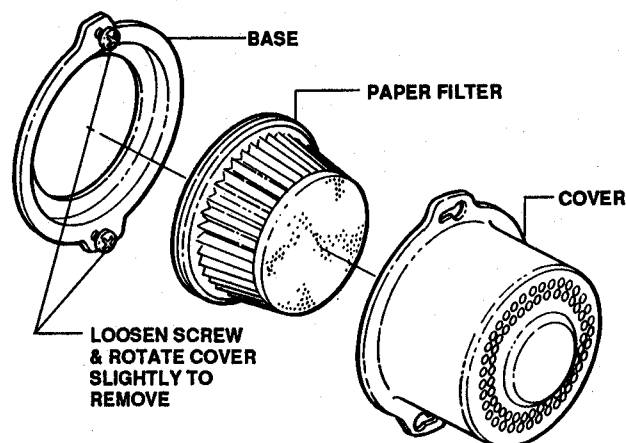

FIGURE 13

# **SNAPPER**<sup>®</sup>

## **OFF-SEASON STORAGE**

Thoroughly clean all external surfaces and tines before storing the Tiller. The Tiller may be stored on end, however, the following steps must be taken.

1. Drain gasoline from fuel system and drain the engine crankcase oil (refer to engine manual for details).
2. After standing the Tiller on end, check the plugs in the chain case for leakage. After extended period, some grease may seep thru upper bearing races.
3. At the start of the new season, replenish engine crankcase oil and add gasoline to the fuel tank after returning the Tiller to its wheels.
4. Before starting, move the ENGINE CONTROL to STOP and pull rope starter slowly several times. If excessive resistance is felt, remove the spark

plug and pull rope starter rapidly to spin the engine and clear oil from the cylinder. Clean and reinstall the spark plug before attempting to start the engine.

## **ACCESSORIES**

Your tiller can be converted to become an even more versatile garden tool with the addition of the optional accessory kits listed below. Contact your **SNAPPER Dealer** for complete information on these and other kits which may be made available later for your **Model IRT4 Series 2 Tiller**.

- HILLER/FURROWER .....#6-0731
- CULTIVATOR SHIELD KIT.....#6-0865
- Contact your **SNAPPER Dealer** for complete information on this kit.

## **SNAPPER TOTAL PROTECTION**

### **FULL TWO-YEAR WARRANTY**

**- NON-COMMERCIAL USERS -**

FOR TWO YEARS FROM THE ORIGINAL PURCHASE DATE OF THIS PRODUCT FOR YOUR NON-COMMERCIAL USE, SNAPPER POWER EQUIPMENT, THROUGH A SNAPPER DEALER, WILL REPAIR THE PRODUCT FREE OF CHARGE, IF IT DOES NOT WORK FOR ANY REASON.

RETURN THE PRODUCT TO A SNAPPER DEALER FOR REPAIR UNDER THIS WARRANTY.

YOU PROVIDE THE USUAL MAINTENANCE AS SPECIFIED IN THE OWNER/OPERATOR MANUALS.

THERE IS NO OTHER EXPRESS WARRANTY.

LIABILITY FOR INCIDENTAL AND CONSEQUENTIAL DAMAGES ARE EXCLUDED. SOME STATES DO NOT ALLOW THE EXCLUSION OF INCIDENTAL OR CONSEQUENTIAL DAMAGES, SO THIS EXCLUSION MAY NOT APPLY TO YOU.

THIS WARRANTY GIVES YOU SPECIFIC LEGAL RIGHTS, AND YOU MAY ALSO HAVE OTHER LEGAL RIGHTS WHICH VARY FROM STATE TO STATE AND COUNTRY TO COUNTRY.

### **LIMITED WARRANTY**

**- COMMERCIAL USERS -**

FOR NINETY (90) DAYS FROM THE ORIGINAL PURCHASE DATE OF THIS PRODUCT FOR YOUR COMMERCIAL USE, SNAPPER POWER EQUIPMENT, THROUGH AN AUTHORIZED SNAPPER DEALER, WILL REPAIR THE PRODUCT FREE OF CHARGE, IF IT IS FOUND TO BE DEFECTIVE IN MATERIAL OR WORKMANSHIP.

RETURN THE PRODUCT TO A SNAPPER DEALER FOR REPAIR UNDER THIS WARRANTY.

YOU PROVIDE THE USUAL MAINTENANCE AS SPECIFIED IN THE OWNER/OPERATOR MANUALS.

THERE IS NO OTHER EXPRESS WARRANTY.

IMPLIED WARRANTIES, INCLUDING THOSE OF MERCHANTABILITY AND FITNESS FOR A PARTICULAR PURPOSE, ARE LIMITED TO NINETY (90) DAYS FROM THE ORIGINAL PURCHASE DATE. SOME STATES DO NOT ALLOW LIMITATIONS ON HOW LONG AN IMPLIED WARRANTY LASTS, SO THE ABOVE LIMITATION MAY NOT APPLY TO YOU.

LIABILITY FOR INCIDENTAL AND CONSEQUENTIAL DAMAGES ARE EXCLUDED. SOME STATES DO NOT ALLOW THE EXCLUSION OR LIMITATION OF INCIDENTAL OR CONSEQUENTIAL DAMAGES, SO THE ABOVE EXCLUSION MAY NOT APPLY TO YOU.

THIS WARRANTY GIVES YOU SPECIFIC LEGAL RIGHTS, AND YOU MAY ALSO HAVE OTHER LEGAL RIGHTS WHICH VARY FROM STATE TO STATE AND COUNTRY TO COUNTRY.

PLEASE COMPLETE THE ATTACHED SNAPPER PRODUCT REGISTRATION CARD AND PROMPTLY MAIL IT TO SNAPPER POWER EQUIPMENT, McDONOUGH, GEORGIA 30253.

**SNAPPER POWER EQUIPMENT**

**McDonough, GA., 30253 U.S.A.**



#1-7228 (IR 9/90 Issue)

Printed in U.S.A.



## Free Manuals Download Website

<http://myh66.com>

<http://usermanuals.us>

<http://www.somanuals.com>

<http://www.4manuals.cc>

<http://www.manual-lib.com>

<http://www.404manual.com>

<http://www.luxmanual.com>

<http://aubethermostatmanual.com>

Golf course search by state

<http://golfingnear.com>

Email search by domain

<http://emailbydomain.com>

Auto manuals search

<http://auto.somanuals.com>

TV manuals search

<http://tv.somanuals.com>