

Stereo Cassette Deck

Operating Instructions

TC-SP55

©2000 Sony Corporation

Do not install the appliance in a confined space, such as a bookcase or built-in cabinet.

This system is equipped with the Dolby* B-type noise reduction system.

* Manufactured under license from Dolby Laboratories.

“Dolby” and the double-D symbol are trademarks of Dolby Laboratories.

The TC-SP55 tape deck is designed only for the CMT-SP55MD Micro Hi-Fi component system

Here are some of the features you can use with this tape deck when connected with the CMT-SP55MD Micro Hi-Fi component system (see page 4).



Auto Power On/Off

The tape deck power is tied with the CMT-SP55MD Micro Hi-Fi component system.

Synchro Recording

You can easily record a CD onto a tape (see pages 6 and 10).

Automatic Source Selection

You can switch from another source to the tape deck and start playing a tape just by pressing  or  on the tape deck (see page 8).

Timer

You can wake up to music or record a radio programme at a preset time. For details, refer to “Falling asleep to music” and “Waking up to music” in the CMT-SP55MD Operating Instructions, and “Timer recording radio programmes” on page 15.

Remote Control

You can operate the tape deck using the remote supplied with CMT-SP55MD.

Table of Contents

Getting Started

Hooking up the system	4
-----------------------------	---

Operations

Recording a CD on a tape	
— CD-TAPE Synchro Recording	6
Playing a tape	7
Recording a tape on an MD	9
Recording your favourite CD tracks on a tape	
— CD-TAPE Synchro Recording	10
Recording an MD on a tape	11
Recording your favourite portions on a tape	
— Manual Recording	13
Recording from the radio	14
Timer recording radio programmes	15

Additional Information

Precautions	17
Troubleshooting	18
Messages	19
Specifications	19
Index	Back cover

Hooking up the system

Perform the following procedure **1** and **2** to hook up your system using the supplied cord.

Note

Be sure to hook up the system with the mains lead unplugged from the mains. Hooking up the system with the mains lead plugged in may cause the system to malfunction.

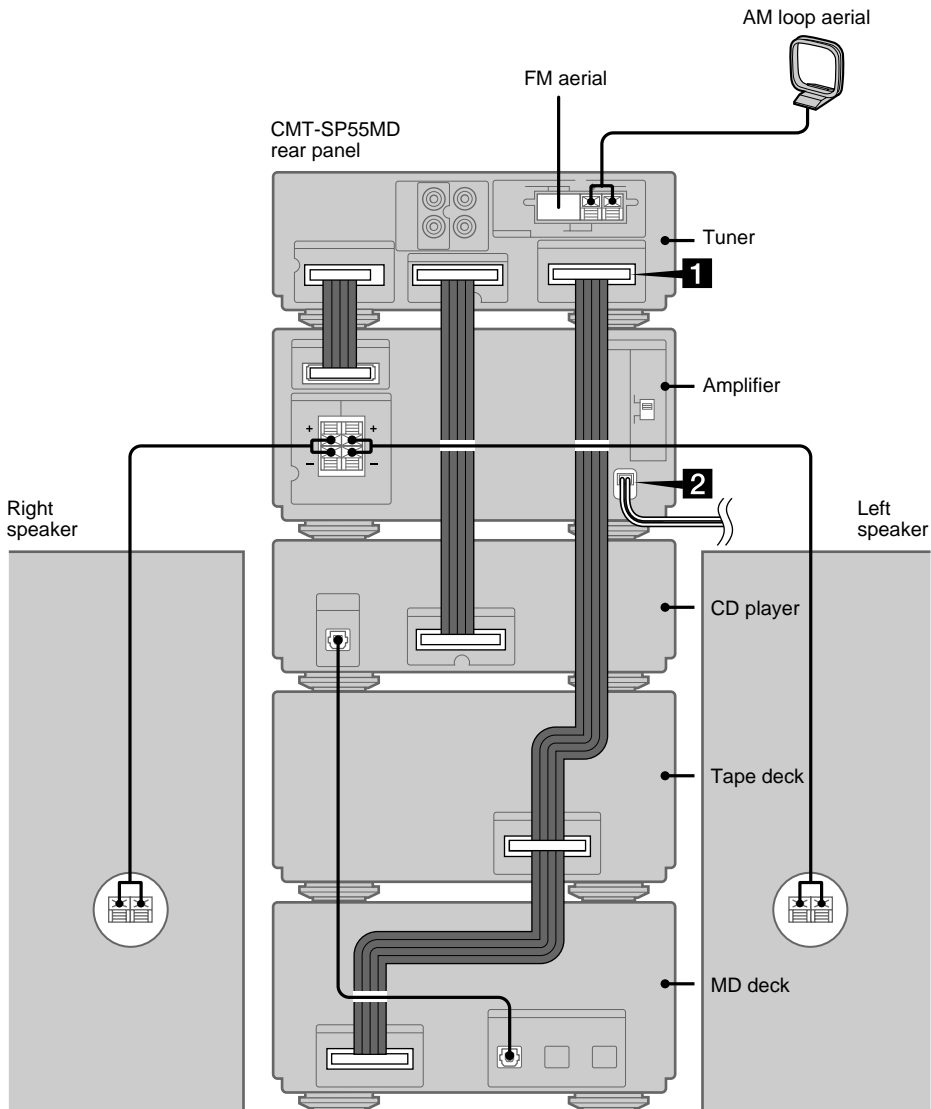

Preparations

- 1 Stack the components vertically in the order of tuner, amplifier, CD player, tape deck and MD deck.
- 2 Disconnect the system cable supplied with CMT-SP55MD from the SYSTEM CONTROL 3 connectors on the tuner and MD deck.

- 1** Connect the SYSTEM CONTROL 3 connectors (red) in the order of the tuner, tape deck and MD deck using the system cable supplied with TC-SP55.

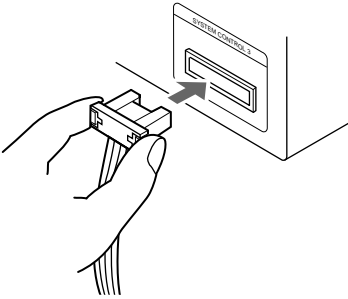

Notes

- The system cable is used to send signals and electricity between the components for interlinked operation.
Be sure to insert the connector horizontally until it clicks into place. Otherwise the system will not operate correctly.
- Keep the system cable away from the aerials to prevent noise or malfunction.

- 2** Connect the mains lead to the mains after you complete all the connections.

Arranging the components side by side

Once you have finished the connections, you can rearrange the components as desired.

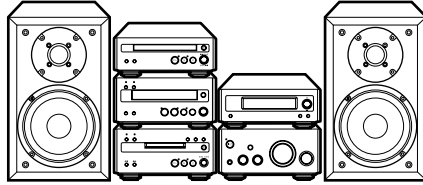

Tip

All information for the TC-SP55 tape deck appears in the display on the tuner of CMT-SP55MD.

Recording a CD on a tape — CD-TAPE Synchro Recording

You can make an analogue recording of a CD on a tape. You can use TYPE I (normal) or TYPE II (CrO₂) tape. The recording level is automatically adjusted.

You can also record a programme of favourite tracks (see page 10).

To turn on the system, press I/⏻ (power).

The tape deck turns on automatically.

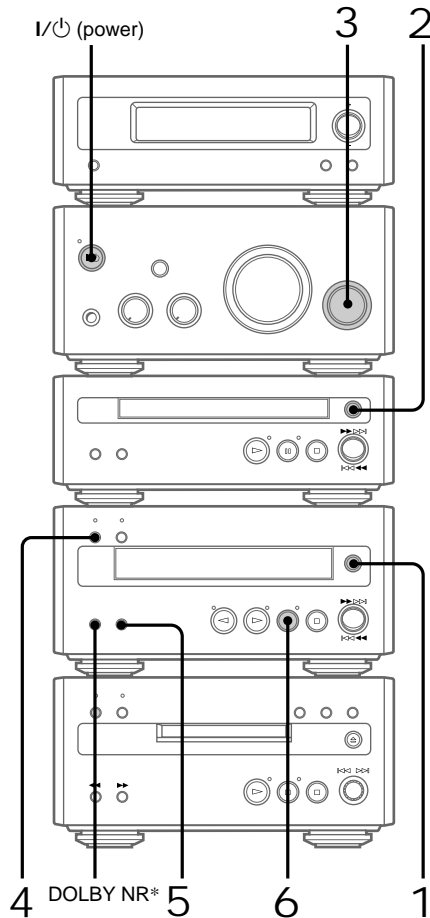

* This tape deck is equipped with the Dolby B-type noise reduction system.

- 1 Press on the tape deck to open the cassette tray and insert a blank tape.

With the side you want to record on facing up.

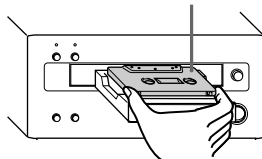

Press again to close the cassette tray.

- 2 Press on the CD player and place a CD on the disc tray.

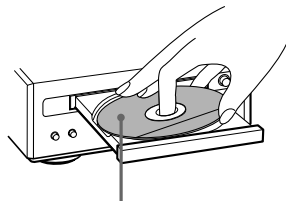

With the label side up. When you play a CD single (8 cm CD), place it on the inner circle of the tray.

Press again to close the disc tray.

- 3 Turn FUNCTION until “CD” appears.

- 4 Press CD SYNC REC on the tape deck. The CD SYNC REC indicator lights up. The tape deck stands by for recording and the CD player pauses for play.

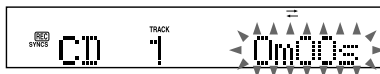

5 Press **DIRECTION** repeatedly until \rightleftarrows appears to record on one side or \rightleftarrows (or \rightleftarrows) to record on both sides.

6 Press \square on the tape deck.
Recording starts.
When the recording is completed, the CD player and the tape deck stop automatically.

To	Do this
Stop recording	Press \square on the tape deck or CD player.
Remove the tape and CD	Press \triangle on the tape deck and CD player in stop mode.

Tips

- When you want to record on the reverse side, press \triangleleft on the tape deck in step 5.
- When you record on both sides, be sure to start from the front side. If you start from the reverse side, recording stops at the end of the reverse side.
- If you select both sides recording and the tape reaches the end of the front side part-way through a track, the entire track is recorded again from the beginning of the reverse side.
- When you want to reduce the hiss noise in high-frequency signals recorded at low level, press **DOLBY NR** after step 5 so "DOLBY NR" appears in the display. Turning **DOLBY NR** on reduces the noise when playing back these types of signals.

Playing a tape

You can use any type of tape, TYPE I (normal), TYPE II (CrO₂) or TYPE IV (metal), since the tape deck automatically detects the tape type (ATS*).

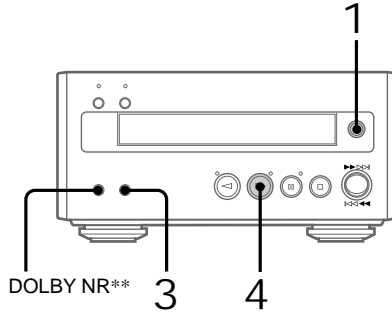

- * ATS: Automatic Tape Selection
- ** This tape deck is equipped with the Dolby B-type noise reduction system.

1 Press \triangle on the tape deck to open the cassette tray and insert a recorded tape.
With the side you want to play facing up.

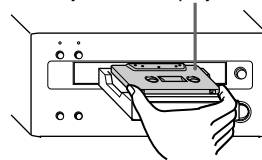

Press \triangle again to close the cassette tray.

2 Turn **FUNCTION** on the amplifier until "TAPE" appears.

3 Press **DIRECTION** repeatedly until \rightleftarrows appears to play one side or \rightleftarrows (or \rightleftarrows *) to play both sides.

- * The tape deck stops automatically after repeating the sequence five times.

continued

Playing a tape (continued)

- 4 Press ▷ on the tape deck.
The indicator on the ▷ button lights up, then the tape starts playing from the front side.
Press ◁ on the tape deck to play the reverse side.

To	Do this
Stop play	Press □ on the tape deck.
Pause	Press ⏸ on the tape deck. The indicator on the ⏸ button lights up. Press again to resume play.
Find the succeeding track (AMS*)	Press ►►► on the tape deck for the front side during playback. Press ◀◀◀ on the tape deck for the reverse side during playback. Each time you press the button, the display shows the number of tracks to be skipped.
Find the preceding track (AMS*)	Press ◀◀◀ on the tape deck for the front side during playback. Press ►►► on the tape deck for the reverse side during playback. Each time you press the button, the display shows the number of tracks to be skipped.

To	Do this
Fast-forward	Press ⏩⏩⏩ or ►►► on the tape deck in stop mode.
Rewind	Press ◀◀◀ or ►►► on the tape deck in stop mode.
Remove or replace the tape	Press ⏏ on the tape deck.
Adjust the volume	Turn VOLUME.

* The Automatic Music Sensor (AMS) feature detects a blank space of more than four seconds between tracks to locate tracks quickly.

Tips

- You can switch from another source to the tape deck and start playing a tape just by pressing ▷ or ◁ on the tape deck (**Automatic Source Selection**).
- To listen to a tape recorded with the Dolby noise reduction system, press DOLBY NR so “DOLBY NR” appears in the display.

Note

The AMS feature may not work in the following cases:

- the blank space between tracks is four seconds or less.
- the sound source recorded on the right channel is different from that on the left channel.
- low volume or low sound continues for a long time.
- the TV is too close to the system.

Recording a tape on an MD

You can make an analogue recording of a tape on an MD. You can use TYPE I (normal), TYPE II (CrO₂) tape. The recording level is automatically adjusted.

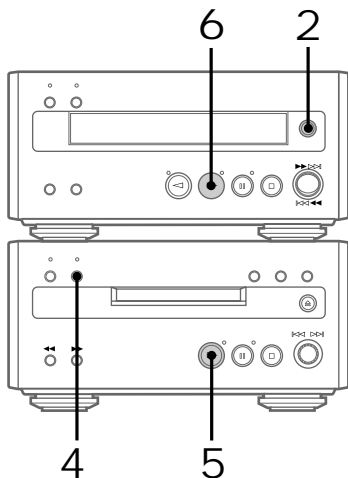

1 Insert a recordable MD.

With the arrow pointing toward the deck.

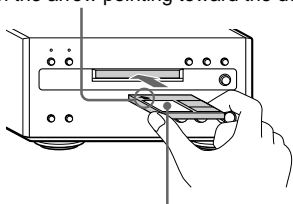

With the label side up, and the shutter on the righthand side.

2 Press on the tape deck to open the cassette tray and inset a tape.

With the side you want to play facing up.

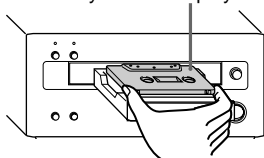

Press  again to close the cassette tray.

3 Turn FUNCTION on the amplifier until "TAPE" appears.

4 Press REC on the MD deck. The MD deck stands by for recording.



Tape playback side

>>> appears for the front side, and <<< for the reverse side. To play the side not indicated, press  on the tape deck and remove the tape to reverse the tape side, then do steps 3 and 4 again.

5 Press on the MD deck. Recording starts.

6 Press on the tape deck.

To stop recording

Press  on the MD deck.

Tips

- If you use a partially recorded MD, recording starts after the recorded tracks. To erase the recorded contents, refer to "Erasing recordings" in the CMT-SP55MD Operating Instructions.
- If the Smart Space function is on and there is no sound input for about 3 seconds or more (but less than 30 seconds) while recording, the MD deck replaces this silence with a blank of about 3 seconds and continues recording. However, this function may not activate if there is noise.

Note

If the MD is record protected, "C11" and "Protected" appear alternately and the MD cannot be recorded. Remove the MD, then slide the record protection tab to the closed position.

Recording your favourite CD tracks on a tape

— CD-TAPE Synchro Recording

You can select your favourite CD tracks with the Programme Play feature, then record the programme on a tape using the Synchro Recording feature. This lets you rearrange the track order while making sure the playback time fits on each side of the tape.

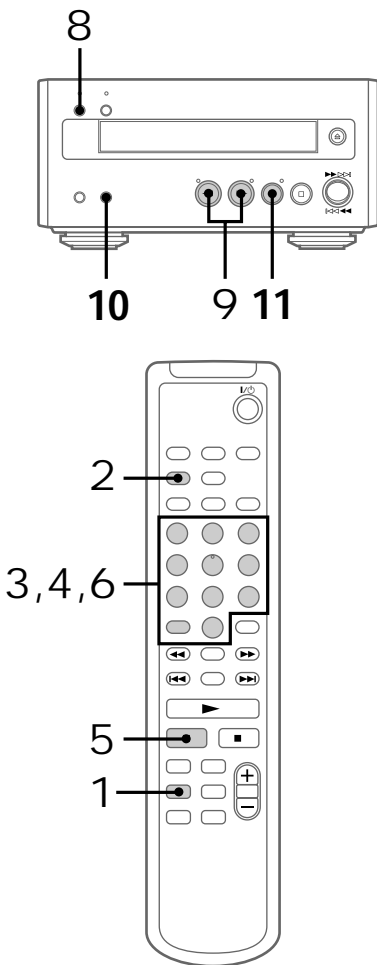

Selecting the tracks

- 1 Press CD on the remote to switch the function to CD.
- 2 Press PLAY MODE on the remote repeatedly until "PROGRAM" appears.

- 3 Press the track number of the track you want to record.

To select track number 11 and higher

Press >10 once and then the number buttons of the track number.

For example, to select track 32, press >10, 3, and 2.

- 4 Repeat step 3 to select the tracks to be recorded on the side where recording is to start.

- 5 Press **II** on the remote.
Recording pauses at the end of the side where recording starts. "P" appears and the total playing time display changes to "0m00s".

- 6 Repeat step 3 to select the tracks to be recorded on the reverse side.

Recording on a tape

- 7 Insert a blank tape.
- 8 Press CD SYNC REC on the tape deck.
The tape deck stands by for recording and the CD player pauses for play.

- 9 Press \triangleright on the tape deck to record starting from the front side.
To record from the reverse side, press \triangleleft on the tape deck.

- 10 Press DIRECTION repeatedly until \rightleftarrows appears to record on one side or \rightleftarrows (or \rightleftarrows) to record on both sides.

If you select both sides recording and the tape reaches the end of the front side part-way through a track, the entire track is recorded again from the beginning of the reverse side. When you start recording from the reverse side, the recording stops at the end of the reverse side even though you select \rightleftarrows .

- 11 Press \square on the tape deck.
CD play and tape recording start.
When the recording is completed, the CD player and the tape deck stop automatically.

To stop recording

Press \square on the tape deck or CD player.

If the tape becomes full during recording

The CD player and the tape deck automatically stop.

Tip

When you want to reduce the hiss noise in high-frequency signals recorded at low level, press DOLBY NR after step 10 so "DOLBY NR" appears in the display. Turning DOLBY NR on reduces the noise when playing back these types of signals.

Recording an MD on a tape

You can make an analogue recording of an MD on a tape with the tracks in the same sequence as the original MD.

You can also record a programme of favourite tracks.

Recording tracks in the same sequence as the original MD

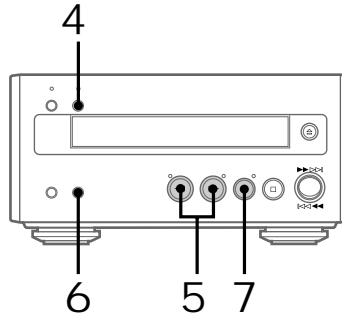

- 1 Insert a blank tape.
- 2 Insert an MD.
- 3 Turn FUNCTION on the amplifier until "MD" appears.
- 4 Press \bullet REC on the tape deck.
The tape deck stands by for recording.
- 5 Press \triangleright on the tape deck to record starting from the front side.
To record from the reverse side, press \triangleleft on the tape deck.

continued

Recording an MD on a tape (continued)

- 6 Press DIRECTION repeatedly until \rightleftarrows appears to record on one side or \rightleftarrows (or \rightleftarrows) to record on both sides.

If you select both sides recording and the tape reaches the end of the front side part-way through a track, the entire track is recorded again from the beginning of the reverse side. When you start recording from the reverse side, the recording stops at the end of the reverse side even though you select \rightleftarrows .

- 7 Press \square on the tape deck.
Recording starts.

- 8 Press \triangleright on the MD deck.
MD play starts.
When the recording is completed, the MD deck stops.

To stop recording

Press \square on the tape deck.

Tip

When you want to reduce the hiss noise in high-frequency signals recorded at low level, press DOLBY NR after step 6 so "DOLBY NR" appears in the display. Turning DOLBY NR on reduces the noise when playing back these types of signals.

Recording your favourite MD tracks

You can select your favourite MD tracks with the Programme Play feature, then record the programme on a tape.

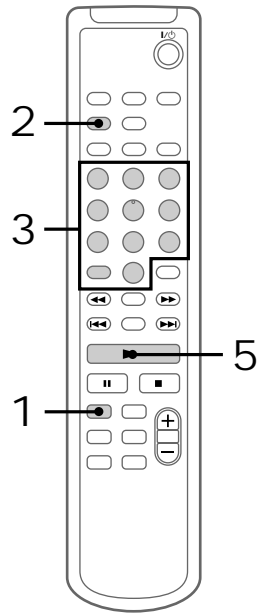

- 1 Press MD to switch the function to MD.
- 2 Press PLAY MODE repeatedly until "PROGRAM" appears in stop mode.

- 3 Press the track number of the track you want to record.

To select track number 11 and higher

Press >10 once and then the number buttons of the track number.

For example, to select track 32, press >10, 3, and 2.

To select track number 100 and higher

Press >10 twice and then the number buttons of the track number.

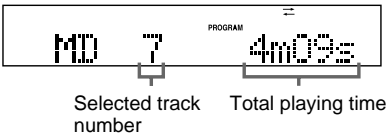

- 4 To programme additional tracks, repeat step 3.

Each time you programme, the total time of the programme is displayed. You can make a programme of up to 25 tracks.

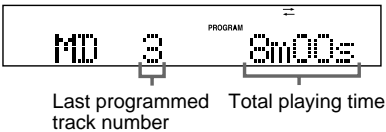

- 5 Insert a blank tape.

- 6 Do steps 3 to 8 of "Recording tracks in the same sequence as the original MD" (see page 11).

Recording your favourite portions on a tape

— Manual Recording

With manual recording, you can record just the portions you like from a CD or an MD on a tape. The recording level is automatically adjusted.

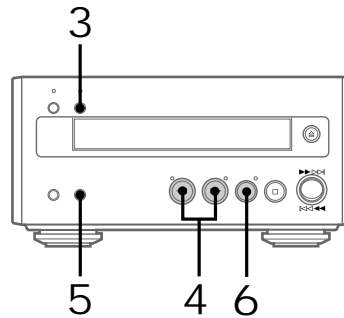

- 1 Insert a blank tape.
- 2 Turn FUNCTION on the amplifier until "CD" or "MD" appears.
 - CD: Recording from the CD
 - MD: Recording from the MD
- 3 Press ● REC on the tape deck. The tape deck stands by for recording.
- 4 Press ▷ on the tape deck to record starting from the front side. To record from the reverse side, press ◁ on the tape deck.

continued

Recording your favourite portions on a tape (continued)

- 5 Press **DIRECTION** repeatedly until \rightleftarrows appears to record on one side or \rightleftarrows (or \rightleftarrows) to record on both sides.

When you start recording from the reverse side, the recording stops at the end of the reverse side even though you select \rightleftarrows .

- 6 Press \square on the tape deck.
Recording starts.

- 7 Press \triangleright on the CD player or MD deck.

To	Press
Stop recording	\square on the tape deck.
Pause	\square on the tape deck.

Tip

When you want to reduce the hiss noise in high-frequency signals recorded at low level, press **DOLBY NR** after step 5 so "DOLBY NR" appears in the display. Turning **DOLBY NR** on reduces the noise when playing back these types of signals.

Recording from the radio

You can make an analogue recording a radio programme on a tape. You can use **TYPE I** (normal) or **TYPE II** (CrO₂) tape. The recording level is automatically adjusted.

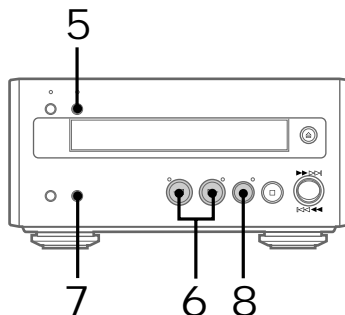

- 1 Insert a blank tape.
- 2 Press **TUNER/BAND** repeatedly on the tuner to select "AM" or "FM".
- 3 Press **TUNING MODE** on the tuner repeatedly until "PRESET" appears.
- 4 Press **TUNING +** or **-** on the tuner to select the desired preset station.



Preset number and frequency (or station name* or RDS station name)

* The station name appears only if you have labelled the station (refer to the **CMT-SP55MD** Operating Instructions).

- 5 Press \bullet **REC** on the tape deck.
The \bullet **REC** indicator lights up.
The tape deck stands by for recording.

- 6 Press ▷ on the tape deck to record starting from the front side.
To record from the reverse side, press ◁ on the tape deck.

- 7 Press DIRECTION repeatedly until ⇔ appears to record on one side or ⇄ (or ⇄⇄) to record on both sides.

If you select both sides recording and the tape reaches the end of the front side part-way through a track, the entire track is recorded again from the beginning of the reverse side. When you start recording from the reverse side, the recording stops at the end of the reverse side even though you select ⇄.

- 8 Press □ on the tape deck.
Recording starts.

To	Do this
Stop recording	Press □ on the tape deck.
Pause	Press □ on the tape deck. Press □ again or ▷ on the tape deck to restart recording.
Remove the tape	Press ⏏ on the tape deck in stop mode.

Tips

- If noise is heard while recording an AM radio programme, move the AM loop aerial to reduce the noise or connect a ground wire to the ⚡ terminal (refer to the CMT-SP55MD Operating Instructions).
- When you record on both sides, be sure to start from the front side. If you start from the reverse side, recording stops at the end of the reverse side.
- If you select both sides recording and the tape reaches the end of the front side part-way through a track, the entire track is recorded again from the beginning of the reverse side.
- When you want to reduce the hiss noise in high-frequency signals recorded at low level, press DOLBY NR after step 7 so “DOLBY NR” appears in the display. Turning DOLBY NR on reduces the noise when playing back these types of signals.

Timer recording radio programmes

To timer record, you must first preset the radio station and set the clock (refer to the CMT-SP55MD Operating Instructions).

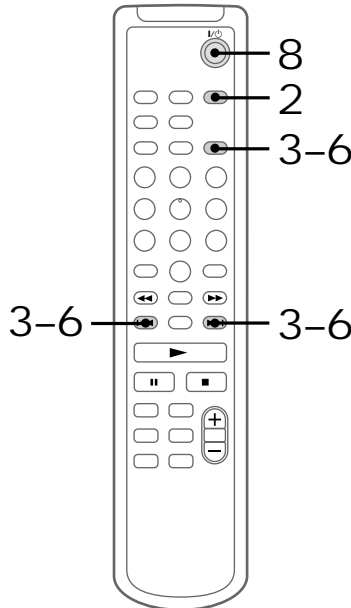

- 1 Tune in the preset radio station (refer to the CMT-SP55MD Operating Instructions).
- 2 Press CLOCK/TIMER SET.
- 3 Press ◀◀ or ▶▶ repeatedly until “SET TAPE REC” appears, then press ENTER/YES.
The hour indication flashes.

continued

Timer recording radio programmes (continued)

-
- 4 Set the time to start recording.
Press ◀◀ or ▶▶ repeatedly to set the hour, then press ENTER/YES.
The minute indication flashes.



Press ◀◀ or ▶▶ repeatedly to set the minute, then press ENTER/YES.
The hour indication flashes again.

-
- 5 Set the time to stop recording following the procedure in step 4.
“OFF TIME NG” appears if the start time and the stop time settings are the same.
Change the stop time.

-
- 6 Press ◀◀ or ▶▶ repeatedly to select the recording source, then press ENTER/YES.

The indication changes as follows:

When recording on a tape

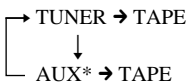

* You can select the connected component for recording source. Set the timer on both systems to the same time.

When you press ENTER/YES, the start time, stop time and other setting contents appear in turn, then the original display returns.

“REC” lights up.

-
- 7 Insert a blank tape.

-
- 8 Press I/⏻ to turn off the system.
-

To cancel the procedure
Press CLOCK/TIMER SET.

To change the setting
Start over from step 1.

To check the setting/activate the timer

Press CLOCK/TIMER SELECT and press ◀◀ or ▶▶ repeatedly until “SEL TAPE REC” appears. Then press ENTER/YES.
It is not necessary to set the start and stop times every time.

To cancel the timer

Press CLOCK/TIMER SELECT and press ◀◀ or ▶▶ repeatedly until “TIMER OFF” appears. Then press ENTER/YES.

Tip

The system automatically turns on about 30 seconds before the start time and prepares for timer-recording. Recording starts as soon as the system is ready, so recording may start earlier than the preset time.

Notes

- You cannot activate Daily Timer and the recording timer at the same time.
- Do not operate the system from the time the system turns on until the recording starts (about 30 seconds before the preset time).
- If the system is on about 30 seconds before the preset time, the timer-recording will not be activated.
- The volume is reduced to minimum during recording.

Precautions

On safety

- The unit is not disconnected from the AC power source (mains) as long as it is connected to the wall outlet, even if the unit itself has been turned off.
- Unplug the system from the mains if it is not to be used for an extended period of time.
To disconnect the mains lead, pull it out by the plug. Never pull the cord itself.
- Should any solid object or liquid fall into the system, unplug the system and have it checked by qualified personnel before operating it any further.
- When you connect the mains lead to the mains, even if the power is off, the system begins charging for remote and timer functions. Therefore the surface of this unit become warm, this is normal.

On placement

- Place the system in a location with adequate ventilation to prevent heat build up.
- Do not place the system in an inclined position.
- Do not place the system in locations where it is;
 - Extremely hot or cold
 - Dusty or dirty
 - Very humid
 - Subject to vibrations
 - Subject to direct sunlight.

On operation

If the system is brought directly from a cold to a warm location, or is placed in a very damp room, moisture may condense on the pinch roller and heads inside the tape deck. Should this occur, the system will not operate properly. Remove the tape and leave the system turned on for about an hour until the moisture evaporates.

If you have any questions or problems concerning your system, please consult your nearest Sony dealer.

Cleaning the cabinet

Use a soft cloth slightly moistened with mild detergent solution.

Before placing a cassette in the tape deck

Take up any slack in the tape. Otherwise, the tape may get entangled in the parts of the tape deck and become damaged.

When using a tape longer than 90 minutes

The tape is very elastic. Do not change the tape operations such as play, stop, and fast-winding frequently. The tape may get entangled in the tape deck.

To save a tape permanently

To prevent a tape from being accidentally recorded over, break off the cassette tab from side A or B as illustrated.

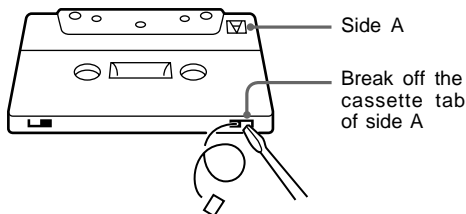
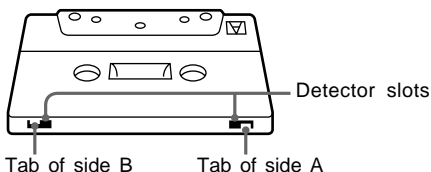

If you later want to reuse the tape for recording, cover the broken tab with adhesive tape. However, be careful not to cover the detector slots which allow the tape deck to automatically detect the type of tape.

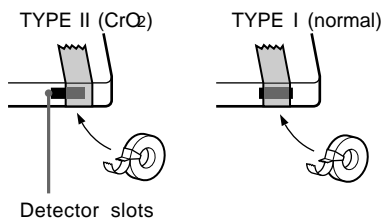

continued

Cleaning the tape heads

Clean the tape heads after every 10 hours of use.

When the tape heads become dirty;

- the sound is distorted
- there is a decrease in sound level
- the sound drops out
- the tape does not erase completely
- the tape does not record.

Be sure to clean the tape heads before you start an important recording or after playing an old tape.

Use a separately sold dry-type or wet-type cleaning cassette. For details, refer to the instructions of the cleaning cassette.

Demagnetising the tape heads

Demagnetise the tape heads and the metal parts that has contact with the tape after every 20 to 30 hours of use with a separately sold demagnetising cassette. For details, refer to the instructions of the demagnetising cassette.

Troubleshooting

If you have any problem using this system, use the following checklist.

First, check that the mains lead is connected firmly and that the speakers are connected correctly and firmly.

Should any problem persist, consult your nearest Sony dealer. When bringing the system in for repairs, be sure to bring in the entire system. This product is a system product, and the entire system is needed to determine the location requiring repair.

The cassette tray does not close.

- Turn on the power again, and close the cassette tray.

The tape does not record.

- No cassette is inserted. Insert a cassette.
- The tab has been removed from the cassette. Cover the broken tab with adhesive tape (see page 17).
- The tape has wound to the end.

The tape does not record or play, or there is a decrease in sound level.

- The heads are dirty. Clean them.
- There is slack in the tape. Take up any slack in the tape.
- The record/playback heads are magnetised. Demagnetise them (see this page).

The tape does not erase completely.

- The record/playback heads are magnetised. Demagnetise them (see this page).

There is excessive wow or flutter, or the sound drops out.

- The capstans or pinch rollers in the tape deck are dirty. Clean them using a cleaning cassette (see this page).

Noise increases or the high frequencies are erased.

- The record/playback heads are magnetised. Demagnetise them (see this page).
-

Messages

One of the following messages may appear or flash in the display during operation.

Cannot SYNC

- There is no tape in the tape deck, or the tab has been removed from the cassette.
 - The tabs and the direction setting do not match.
-

No TAB

You cannot record the tape because the tab has been removed from the cassette.

No Tape

There is no tape in the tape deck.

Specifications

Tape deck section (TC-SP55)

Recording system	4-track 2-channel stereo (DOLBY NR OFF)
Frequency response	40 – 14,000 Hz (± 3 dB), using Sony TYPE I cassettes 40 – 15,000 Hz (± 3 dB), using Sony TYPE II cassettes

General

Dimensions (w/h/d) incl. projecting parts and controls	Approx. 202 × 101 × 283 mm
Mass	Approx. 1.9 kg
Supplied accessory	System cable (1)

Design and specifications are subject to change without notice.

Index

A, B

Adjusting the volume 8
Automatic Source Selection 8

C, D, E, F, G

CD-TAPE Synchro Recording 6,
10
Connecting. *See* Hooking up

H, I, J, K, L

Hooking up the system 4

M, N, O

Messages 19

P, Q

Playing a tape 7
Protecting recordings 17

R

Recording
 a CD 6, 10, 13
 a radio programme 14
 a tape 9
 an MD 11, 13
 manual recording 13, 14
 timer-recording 15

S

Saving recordings 17

T, U, V, W, X, Y, Z

Timer-recording 15
Troubleshooting 18

Free Manuals Download Website

<http://myh66.com>

<http://usermanuals.us>

<http://www.somanuals.com>

<http://www.4manuals.cc>

<http://www.manual-lib.com>

<http://www.404manual.com>

<http://www.luxmanual.com>

<http://aubethermostatmanual.com>

Golf course search by state

<http://golfingnear.com>

Email search by domain

<http://emailbydomain.com>

Auto manuals search

<http://auto.somanuals.com>

TV manuals search

<http://tv.somanuals.com>