

Cordless Telephone ***with Answering System***

Operating Instructions

US

900^{MHz}
CALLER ID
with call waiting

SPP-A1070

Owner's Record

The model and the serial numbers are located at the bottom of the unit. Record the serial number in the space provided below. Refer to these numbers whenever you call upon your Sony dealer regarding this product.

Model No. SPP-A1070

Serial No. _____

IMPORTANT SAFETY INSTRUCTIONS

When using your telephone equipment, basic safety precautions should always be followed to reduce the risk of fire, electric shock and injury to persons, including the following:

1. Do not use this product near water, for example, near a bath tub, wash bowl, kitchen sink, or laundry tub, in a wet basement, or near a swimming pool.
2. Avoid using a telephone (other than a cordless type) during an electrical storm. There may be a remote risk of electric shock from lightning.
3. Do not use the telephone to report a gas leak in the vicinity of the leak.
4. Use only the power cord and batteries indicated in this manual. Do not dispose of batteries in a fire. They may explode. Check with local codes for possible special disposal instructions.

SAVE THESE INSTRUCTIONS

INFORMATION FOR FCC REGULATION CLAIM

1. This equipment complies with Part 15 and Part 68 of the FCC rules for the United States. On the bottom of this equipment is a label that contains, among other information, the FCC certification number and ringer equivalence number (REN) for this equipment. If requested, this information must be provided to the telephone company.
2. This equipment connect to nationwide telephone network through a modular telephone jack which applicable certification jack (connector) is USOC-RJ11C.
3. The FCC compliant telephone cord and modular plug is provided with this equipment. This equipment is designed to be connected to the telephone network or premises wiring using a compatible modular jack that is part 68 compliant.
4. The REN is used to determine the quantity of devices that may be connected to the telephone line. Excessive RENs on the telephone line may result in the devices not ringing in response to an incoming call. Typically, the sum of the RENs should not exceed five (5.0). To be certain of the number of devices that may be connected to a line, as determined by the total RENs, contact the local telephone company.
5. If this equipment (SPP-A1070) causes harm to the telephone network, the telephone company will notify you in advance that temporary discontinuance of service may be required. But if advance notice isn't practical, the telephone company will notify the customer as soon as possible. Also, you will be advised of your right to file a complaint with the FCC if you believe it is necessary.
6. The telephone company may make changes to it's facilities, equipment, operations or procedures that could affect the operation of the equipment. If this happens the telephone company will provide advance notice so you can make the necessary modifications to maintain uninterrupted service.
7. If trouble is experienced with this equipment (SPP-A1070), for repair or warranty information, please contact Sony Direct Response Center: Tel 1-800-222-7669. If the equipment is causing harm to the telephone network, the telephone company may request that you disconnect the equipment until the problem is resolved.
8. All repairs will be performed in an authorized Sony service station.

9. This equipment may not be used on coin service provided by the Phone Company or Party Lines.

10. This equipment is hearing aid compatible.

When programming emergency numbers and (or) making test calls to emergency numbers:

1. Remain on the line and briefly explain to the dispatcher the reason for the call.
2. Perform such activities in the off-peak hours, such as early morning or late evenings.

Operation is subject to the following two conditions: (1) This device may not cause interference, and (2) This device must accept any interference, including interference that may cause undesired operation.

Caution

You are cautioned that any changes or modifications not expressly approved in this manual could void your authority to operate this equipment.

Privacy of communications may not be ensured when using this phone.

Note

This equipment has been tested and found to comply with the limits for a Class B digital device, pursuant to Part 15 of the FCC Rules. These limits are designed to provide reasonable protection against harmful interference in a residential installation. This equipment generates, uses and can radiate radio frequency energy and, if not installed and used in accordance with the instructions, may cause harmful interference to radio communications. However, there is no guarantee that interference will not occur in a particular installation. If this equipment does cause harmful interference to radio or television reception, which can be determined by turning the equipment off and on, the user is encouraged to try to correct the interference by one or more of the following measures:

- Reorient or relocate the receiving antenna.
- Increase the separation between the equipment and receiver.
- Connect the equipment into an outlet on a circuit different from that to which the receiver is connected.
- Consult the dealer or an experienced radio/TV technician for help.

IMPORTANTES INSTRUCCIONES DE SEGURIDAD

A fin de reducir el riesgo de incendio, descarga eléctrica y lesiones a las personas cuando usted use su equipo telefónico, siempre debe observar precauciones básicas de seguridad, entre ellas:

1. No use este producto cerca del agua, por ejemplo, cerca de una bañera, lavabo, fregadero de cocina o lavadora, en un sótano mojado o cerca de una piscina.
2. Evite usar un teléfono (que no sea del tipo inalámbricos) durante una tormenta eléctrica. Existe la remota posibilidad de shock eléctrico debido a rayos.
3. Para notificar una fuga de gas, no utilice el teléfono en la vecindad de dicha fuga.
4. Utilice solamente el cable de alimentación y las pilas indicados en este manual. No tire las pilas al fuego. Podrían explotar. Compruebe los códigos locales con respecto a las instrucciones especiales sobre cómo deshacerse de ellas.

GUARDE ESTAS INSTRUCCIONES

INFORMACIÓN PARA LA DEMANDA DE LA REGLAMENTACIÓN DE LA FCC

1. Este equipo cumple con la Parte 15 y la Parte 68 de las reglas de la FCC para EE.UU. En la base de este equipo hay una etiqueta que contiene, entre otra información, el número de certificado de la FCC y el número de equivalencia de timbre de llamada (REN) para este equipo. Cuando se solicite, esta información deberá ofrecerse a la compañía telefónica.

2. Este equipo se conecta a la red telefónica nacional a través de una toma telefónica modular cuya toma (conector) de certificado aplicable es USOC-RJ11C.
3. Con este equipo se suministran un cable telefónico y una clavija modular que cumplen las normas de la FCC. Este equipo ha sido diseñado para conectarse a la red telefónica o la instalación de un usuario utilizando una toma modular compatible que esté de acuerdo con la Parte 68.
4. El REN se utiliza para determinar la cantidad de dispositivos que podrán conectarse a la línea telefónica. El exceso de REN conectados a la línea telefónica puede resultar en que los dispositivos no contesten a llamadas entrantes. Normalmente, la suma de REN no deberá ser superior a cinco (5,0). Para enterarse del número total de REN que puede conectarse a una línea, póngase en contacto con la compañía telefónica.
5. Si este equipo (SPP-A1070) produce daños en la red telefónica, la compañía telefónica le notificará con antelación que es posible que se requiera la interrupción temporal del servicio. Pero si la notificación con antelación no es práctica, la compañía telefónica lo notificará al cliente lo antes posible. Además, se le notificará el derecho a realizar una reclamación a la FCC si usted lo considera necesario.
6. La compañía telefónica puede realizar cambios en sus instalaciones, equipos, operaciones, o procedimientos que pueden afectar la operación del equipo. Cuando suceda esto, la compañía telefónica le avisará con antelación para que pueda realizar las modificaciones necesarias a fin de mantener ininterrumpido el servicio.
7. Si experimenta algún problema con este equipo (SPP-A1070), con respecto a la reparación o a la información sobre la garantía, póngase en contacto con Sony Direct Response Center: Tel 1-800-222-7669 (EE. UU. solamente). Si el equipo causa problemas en la línea, la compañía telefónica puede solicitarle que desconecte el equipo hasta que se resuelva el problema.
8. Todas las reparaciones deberá realizarlas un centro de reparaciones Sony.
9. Este equipo puede no utilizarse en el servicio de pago previo proporcionado por la compañía telefónica o la línea compartida.
10. Este equipo es compatible con dispositivos para ayuda a la audición.

Cuando programe números de emergencia y (o) realice llamadas de prueba a los mismos:

1. Permanezca poco tiempo en la línea y explique a la otra parte la razón de la llamada.
2. Realice tales actividades en horas no punta, como por la mañana temprano o a últimas horas de la tarde.

La operación está sometida a las dos condiciones siguientes: (1) Este dispositivo puede no causar interferencia, y (2) Este dispositivo deberá aceptar cualquier interferencia, incluyendo la que pueda causar una operación indeseada.

Precaución

Se le advierte que cualquier cambio o modificación no aprobado expresamente en el presente manual podría anular su autorización para operar este equipo.

El secreto de las comunicaciones puede no asegurarse cuando utilice este teléfono.

Nota

Este equipo se ha sometido a pruebas y se ha determinado que cumple los límites para un aparato digital Clase B de conformidad con la Parte 15 de las Reglas FCC. Dichos límites están diseñados para brindar protección razonable contra interferencia dañina en una instalación residencial. Este equipo genera, utiliza y puede radiar energía de radiofrecuencia y, si no se instala y se usa de acuerdo con las instrucciones, puede ocasionar interferencia dañina en las radiocomunicaciones. Sin embargo, no hay garantía de que no ocurra interferencia en una instalación específica. En caso de que este equipo ocasione interferencia dañina en la recepción de radio o televisión, que se puede determinar apagando y encendiendo el equipo, se le insta al usuario a que trate de corregir la interferencia mediante una o más de las siguientes medidas:

- Reorientar o reubicar la antena de recepción.
- Aumentar la separación entre el equipo y el receptor.
- Conectar el equipo en un enchufe de un circuito distinto al circuito al cual está conectado el receptor.
- Consultar con el distribuidor o con un técnico experimentado de radio / televisión para ayuda.

Table of contents

Getting Started

- 6 Step 1: Settin up the base unit
 - 9 Step 2: Prepare the battery pack
 - 11 Step 3: Change the display language
 - 12 Step 4: Choose the dialing mode
 - 13 Step 5: Set the date and time
 - 14 Identifying the parts
-

Basics

- 18 Making calls
 - 20 Redialing
 - 21 Receiving calls
-

Telephone Features

- 22 One-touch dialing
- 22 Storing phone number
- 23 Making calls with one-touch dialing
- 24 Phone Directory
- 24 Storing phone numbers and names
- 25 Changing a stored name and/or phone number
- 26 Erasing a memory location
- 27 Making calls from the Phone Directory
- 28 Setting the ringer type
- 28 Turning off the ringer of the handset
- 29 Locating the handset

Answering Machine Features

- 30 Setting up the answering machine
- 30 Setting the time and day of the week
- 31 Recording the greeting
- 33 Setting the number of rings
- 34 Setting the audible message alert
- 35 Turning on the answering function

- 37 Playing back messages
- 38 Adjusting the speaker volume
- 38 Erasing messages
- 39 Selecting the Announcement Only Mode
- 40 Screening calls
- 41 Recording a memo message
- 42 Operating from an outside phone
- 42 Setting the remote ID code (security code)
- 43 Picking up new messages

Caller ID Features

- 45 Understanding the Caller ID service
- 45 When you receive a call
- 46 Looking at the Caller ID list
- 46 Viewing the Caller ID list
- 47 Erasing data from the Caller ID list
- 49 Using the Caller ID list
- 49 Calling back a number from the Caller ID list
- 50 Storing a number of the Caller ID list into the Phone Directory
- 51 To change the number of digits of the phone number
- 53 Using "Caller ID with call waiting" service

Additional Information

- 54 Mounting the base unit on a wall
 - 55 Carrying the handset by the belt clip
 - 57 Notes on power sources
 - 58 Maintenance
 - 59 Troubleshooting
 - 62 Specifications
 - 63 Index
-

Back cover LIMITED WARRANTY

Step 1

Setting up the base unit

Do the following steps:

- Choose the best location
- Connect the base unit

Choose the best location

Where you place the base unit affects the reception quality of the handset.

Away from television sets and other electronic equipment

Away from noise sources such as a window by a street with heavy traffic

Away from heat sources, such as radiators, airducts, and sunlight

Away from a microwave oven

Away from excessive moisture, extremely low temperatures, dust, mechanical vibration, or shock

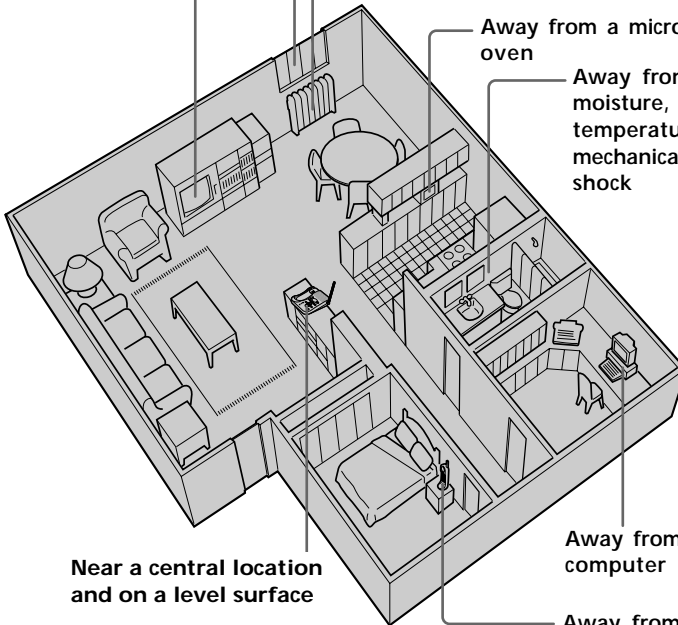

Near a central location and on a level surface

Away from a personal computer

Away from another cordless telephone

- CAUTION:**
- Should you experience intermittent loss of audio during a conversation, try moving closer to the base or move base unit away from other noise sources.
 - The cordless telephone operates at a frequency that may cause interference to nearby TVs and VCRs; the base unit should not be placed near or on the top of a TV or VCR; and, if interference is experienced, moving the cordless telephone farther away from the TV or VCR will often reduce or eliminate the interference.

Connect the base unit

If you want to hang the base unit on the wall, see page 54.

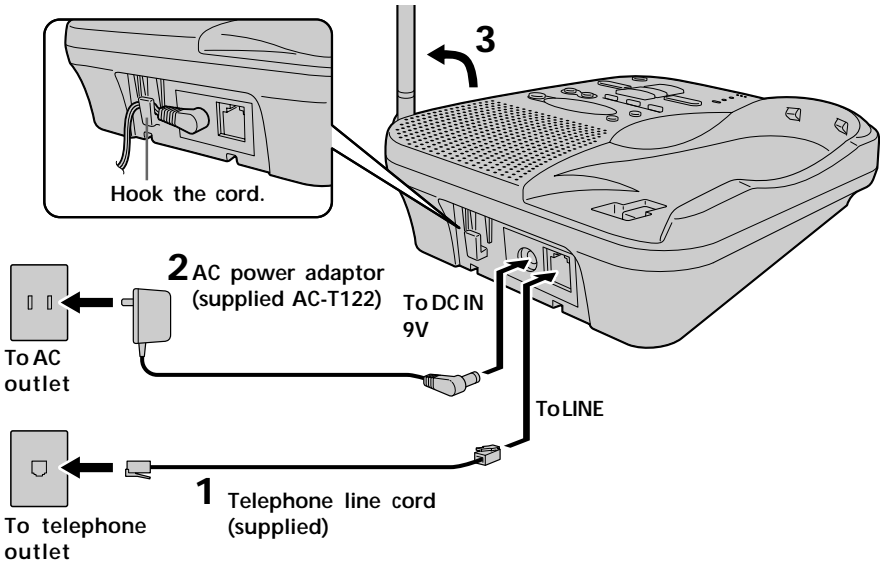

- 1** Connect the telephone line cord to the LINE jack and to a telephone outlet.
- 2** Connect the AC power adaptor to the DC IN 9V jack and to an AC outlet.
- 3** Raise the antenna. Make sure it points towards the ceiling.

continued

Step 1: Setting up the base unit (continued)

Notes

- Use only the supplied AC-T122 AC power adaptor. Do not use any other AC power adaptor.
- Connect the AC power adaptor to a continuous power supply.
- Place the base unit close to the AC outlet so that you can unplug the AC power adaptor easily.

Polarity of the plug



Tip

If your telephone outlet is not modular, contact your telephone service company for assistance.

Modular



Step 2

Prepare the battery pack

Charge the battery pack for more than 12 hours before you start using your phone.

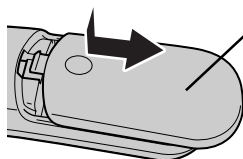

- 1** Slide open the battery compartment lid of the handset.

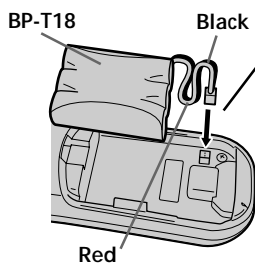

- 2** Connect the battery connector with correct polarity (black wire goes on right side and red wire goes on left).

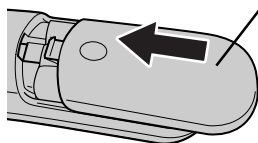

- 3** Insert the battery pack, and close the lid.

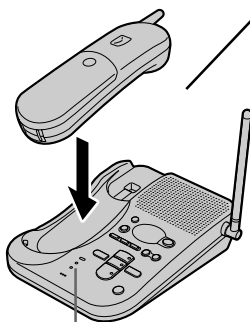

- 4** Place the handset on the base unit.
The CHARGE lamp lights up when the handset is properly seated on the charge terminals of the base unit. Charge the battery pack for more than 12 hours so that the battery is fully charged. The CHARGE lamp remains lit even after charging is completed.

continued

Step 2: Prepare the battery pack (continued)

Battery duration

A fully charged battery pack lasts for:

- Approx. 7 hours when you use the handset continuously
- Approx. 7 days when the handset is in standby mode.

Notes

- The battery pack will gradually discharge over a long period of time, even when not in use.
- If you leave the battery pack in the handset without charging it, the battery pack will be completely discharged.
It may require several times of charging to recover to its full capacity.
- While charging, the battery pack warms up. This is not a malfunction.

To obtain the best performance from the battery

Do not place the handset on the base unit after each call. The battery works best if the handset is returned to the base unit after two or three calls. However, do not leave the handset off the base unit for a long period of time as this will completely discharge the battery pack.

When to purchase a new battery pack

If the battery lasts only a few minutes even after **12 hours** of charging, the usable life of the battery has expired and needs replacement. Contact your local Sony authorized dealer or service center, and ask for Sony **BP-T18** rechargeable battery pack.

Note

Battery life may vary depending on usage condition and ambient temperature.

Step 3

Change the display language

You can choose English or Spanish as the display language by following the procedure below.

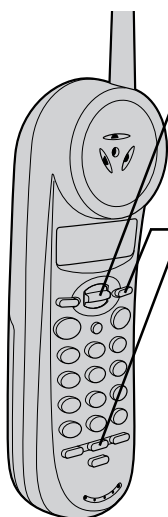

- 1 Press **PGM**.
- 2 Raise or lower the Jog lever until “LANGUAGE” or “IDIOMA” appears on the display.
- 3 Press **SELECT**.



- 4 Raise or lower the Jog lever to change the display language, and then press **PGM**.

You will hear a long confirmation beep.

Note

Do not allow more than 20 seconds to elapse between each step of the procedure.

Tip

You may press **SELECT** instead of pressing **PGM** in step 4.

Step 4

Choose the dialing mode

For the telephone to work properly, select an appropriate dialing mode (tone or pulse).

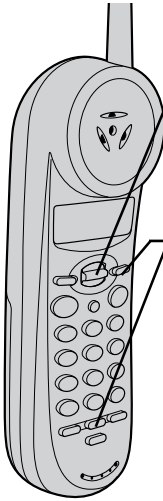

1 Press **PGM**.

2 Raise or lower the Jog lever until “DIAL MODE” appears on the display.

3 Press **SELECT**.



4 Raise or lower the Jog lever to choose the dialing mode (“TONE” or “PULSE”), and then press **PGM**.
You will hear a long confirmation beep.

Note

Do not allow more than 20 seconds to elapse between each step of the procedure.

Tip

You may press **SELECT** instead of pressing **PGM** in step 4.

If you aren't sure of your dialing system

Make a trial call with the dialing mode set to “TONE”.

If the call connects, leave the setting as is; otherwise, set to “PULSE”.

Step 5

Set the date and time

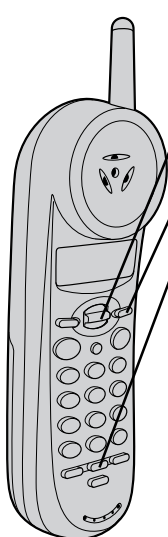

- 1 Press **(PGM)**.
- 2 Raise or lower the Jog lever until "DATE/TIME" appears on the display.
- 3 Press **(SELECT)**.



- 4 Set the correct month using the Jog lever, then press **(SELECT)**.
- 5 Set the correct day, hour (1 to 12) and minute (00 to 59) as in step 4.
- 6 Choose "AM" or "PM" using the Jog lever, then press **(PGM)**.

You will hear a long confirmation beep and the phone starts counting time.

Tip

You may press **(SELECT)** instead of pressing **(PGM)** in step 6.

Identifying the parts

Refer to the pages indicated in parentheses for details.

Base Unit

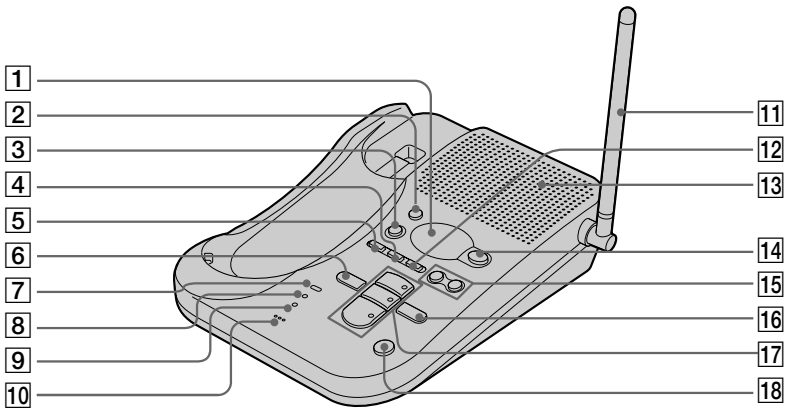

1 Message counter (p. 35, 61)

Indicates the number of new messages recorded. "A" appears in the announcement only mode. "F" appears when there is no space to record messages. "CL" flashes when the power is turned on.

2 REC/MEMO button (p. 31, 41)

Press to record a greeting.
Also used to record a memo message.

3 ERASE button (p. 32, 38)

Erases the recorded greeting or messages.

4 SELECT button (p. 30)

Press to enter the selection and bring you to the next selection.

5 TIME/SET button (p. 30)

Press to check the current time.
Also used to set the timer of the base unit.

6 REPEAT/SLOW button (p. 37)

Press to repeat the current message.
Also used to go back to the previous message or to play the message slowly.

7 NEW CALL lamp (p. 46)

Flashes when there is a "NEW" data in the Caller ID list.

8 CHARGE lamp (p. 9, 19)

Lights while the battery is being charged.

9 LINE lamp (p. 18)

Lights when the handset is in use.

10 MIC (microphone) (p. 31, 41)

11 Antenna (p. 7, 54)

12 MENU button (p. 30, 42)

Press repeatedly to select a setting item when setting up the answering machine.

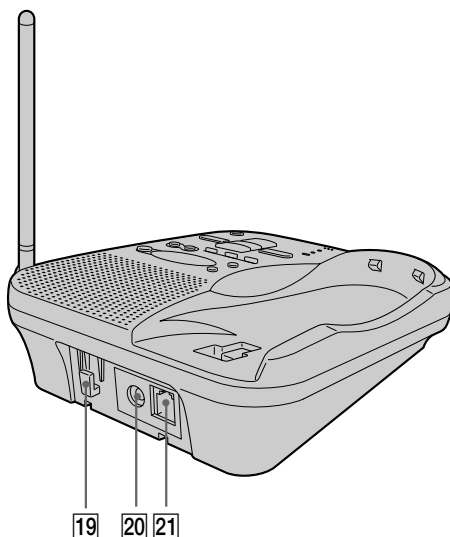

- 13 Speaker** (p. 38)
- 14 ANSWER ON/OFF button** (p. 35)
Turns the answering function on or off. Lights when the answering function is on, and flashes when a new message is recorded.
- 15 VOLUME +/- buttons** (p. 38)
Adjusts the speaker volume.
- 16 SKIP/QUICK button** (p. 37)
Press to skip to the next message. Keep the button pressed for quick playback of messages.
- 17 PLAY/STOP (MAILBOX 1, 2, 3) buttons** (p. 37, 38)
Plays back the messages in each mail box.
- 18 HANDSET LOCATOR button** (p. 29)
Allows you to page the handset.
- 19 Hook for AC power adaptor cord** (p. 7)
- 20 DC IN 9V jack** (p. 7)
- 21 LINE (telephone line) jack** (p. 7)

continued

Identifying the parts (continued)

Handset

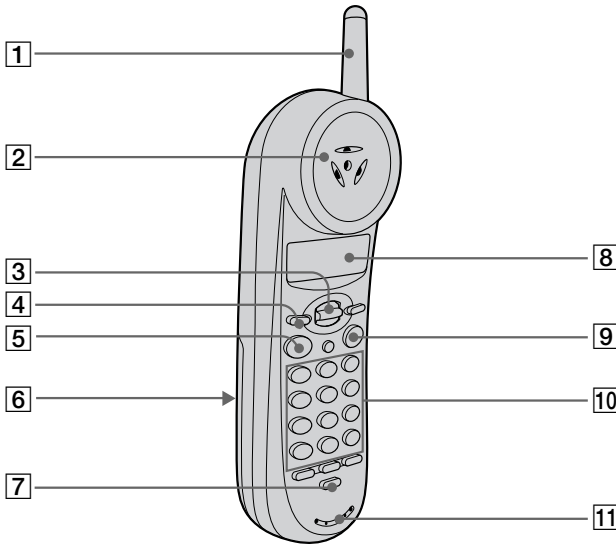

- | | |
|--|--|
| 1 Antenna | 10 Dialing keys |
| 2 Speaker | 11 Microphone |
| 3 Jog lever (p. 11, 22, 46) | 12 FLASH button (p. 18, 53)
Switches to a second call if you have "call waiting" service, or lets you make a new call. |
| 4 HOLD button (p. 18)
Press to put a call on hold. | 13 ✖ TONE button (p. 18)
Allows you to switch temporarily to tone dialing. |
| 5 TALK button (p. 18)
Lets you make or receive a call. | 14 ONE-TOUCH button (p. 23) |
| 6 Battery compartment (p. 9) | 15 🎧 (HEADSET) jack (p. 56) |
| 7 CHANNEL button (p. 18)
Press to select a better channel. | 16 SELECT button (p. 11, 22, 24, 48)
Press to enter the selection and bring you to the next selection. |
| 8 Display (p. 11, 45) | |
| 9 OFF button (p. 18)
Allows you to disconnect the call. | |

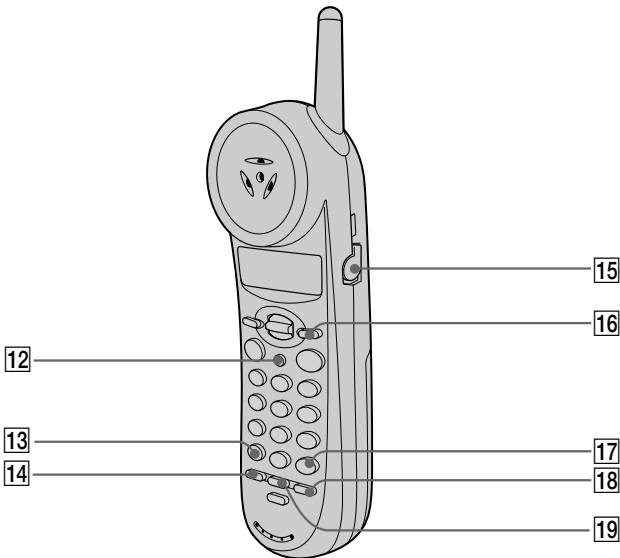

17 # button (p. 51)

Used to change the number of digits of the phone number in the Caller ID list.

18 REDIAL/PAUSE button (p. 20, 23)

Redials the last number called/ inserts a pause in the dialing sequence.

19 PGM (Program) button (p. 11, 22, 24)

Press to start the procedure for setting up the phone such as choosing the dialing mode.

Also used to store the setting to finish the procedure.

Making calls

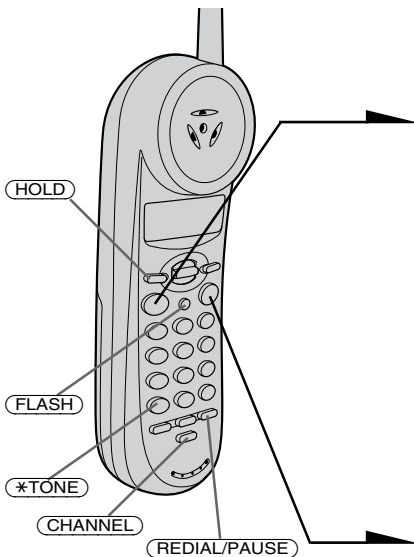

- 1** Pick up the handset from the base unit.
- 2** Press **TALK** and wait until “TALK” appears on the display. You will then hear a dial tone. The LINE lamp on the base unit lights up. If “NO CONNECT” appears on the display, move closer to the base unit.
- 3** Dial the phone number.
- 4** When you’re done talking, press **OFF** or replace the handset on the base unit. The display and the LINE lamp on the base unit go off.

Additional tasks

To	Do this
Select a better channel	Press CHANNEL .
Adjust the handset volume	Raise or lower the Jog lever to set the handset volume.
Put a call on hold	Press HOLD . Press HOLD or TALK to resume the conversation.
Switch to tone dialing temporarily	Press *TONE after you’re connected. “ ! ” appears on the display. The line will remain in tone dialing until disconnected.
Switch to another call (“call waiting” service*)	Press FLASH . Press FLASH again to return to the first caller.
Turn on/off the ringer of the handset	See page 28.

* You need to subscribe to the service from your telephone company.

Notes

- When you increase the sound volume, in some cases the background noise may be increased as well. You should adjust the volume accordingly.
- If another call comes in by “call waiting” service while conversing with an outside caller, you will hear two short beeps.

Tip

To inform you of an incoming call, the display shows “ ** RINGING**” when ringing.

If the battery becomes weak during a call

The handset will beep every few seconds and  and “BATTERY LOW” appears on the display. Finish your call and charge the battery pack.

For optimum performance, charge the battery for a full 12 hours.

Note that during the first 10 - 15 minutes of charging, the phone will be inactive, i.e., unable to make or receive a call. At this time, “NEEDS RECHARGING” appears on the display and the CHARGE lamp flashes.

After this initial 10 - 15 minutes, you **may** be able to use the phone, but the battery duration will be **very short**; thus it is recommended that you **fully charge** the battery before the next usage.

continued

Making calls (continued)

Redialing

- 1 Press **TALK** and wait until “TALK” appears on the display.
The LINE lamp on the base unit lights up.
- 2 Press **REDIAL/PAUSE** to redial the last number dialed.

Note

If the number exceeds 32 digits or if it is erased, five short error beeps will alert you that the number cannot be redialed.

To check the phone number before redialing

While the handset is not in use, press **REDIAL/PAUSE**.

The last number dialed is displayed for five seconds.

To dial the number, press **TALK** while the number is displayed.

Note

The number will not be displayed if the last number dialed exceeds 32 digits or if it is erased.

To erase the last phone number dialed

While the handset is not in use, press **REDIAL/PAUSE** twice within five seconds.

The number will be erased from the memory, and you will hear a long confirmation beep.

Receiving calls

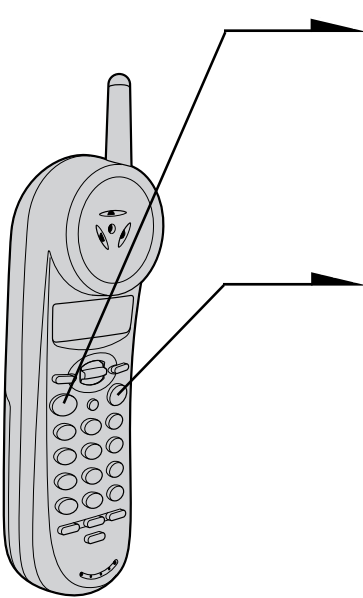

1 When you hear the phone ring, pick up the handset from the base unit, and press **TALK**.
“TALK” appears on the display.
The LINE lamp on the base unit lights up.

2 When you’re done talking, press **OFF** or replace the handset on the base unit.
The display and the LINE lamp on the base unit go off.

If you have subscribed to the Caller ID service

The caller’s number and/or name appears on the display when you receive a call (see page 45). If you receive a call by someone you do not want to answer, press **OFF** to stop the ringer.

One-touch dialing

You can dial with one touch of the key by storing a phone number on the one-touch dialing button. When making long distance calls, it is convenient if the access number of the long distance call service provider is stored beforehand to one-touch dialing button.

Storing phone number

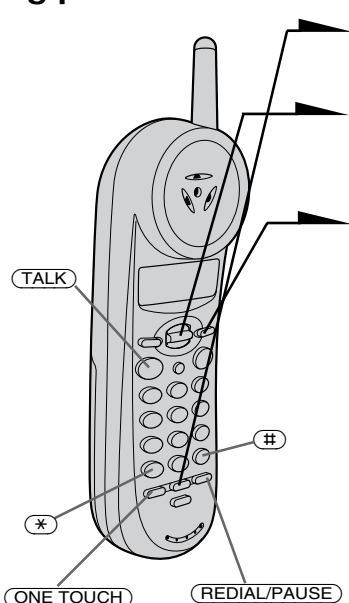

- 1** Press **PGM**.
- 2** Display "SET ONE TOUCH" using the Jog lever.
- 3** Press **SELECT**.

If a number is stored, it appears on the display.
To store a new number, lower the Jog lever several times to erase it.

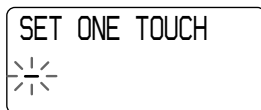

- 4** Enter the phone number.
You can enter up to 16 digits, including a tone and a pause, each of which is counted as one digit.

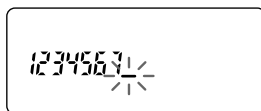

- 5** Press **PGM**.
You will hear a long confirmation beep, and the number is stored.
The display goes off.

Note

Do not allow more than 20 seconds to elapse between each step of the procedure.

Tips

- You may press **(ONE TOUCH)** instead of doing steps 2 and 3.
- The entered phone number **(*)** and **(#)** are displayed as “*” and “#” respectively in step 4.
- You may press **(SELECT)** instead of pressing **(PGM)** in step 5.

To store a number to be dialed via Private Branch Exchange (PBX)

Before entering a phone number in step 4 above, do as follows:

- 1 Enter the outside line access digit (e.g., 9).
- 2 Press **(REDIAL/PAUSE)**.

Making calls with one-touch dialing

- 1 Press **(TALK)** and wait until “TALK” appears on the display.
- 2 Press **(ONE TOUCH)**.

The phone number stored on the one-touch dialing button will appear on the display and will be dialed.

Making Long Distance Calls with one-touch dialing

First of all, store the access number in “Storing phone number” above-mentioned steps, then do as follows:

- 1 Perform steps 1 and 2 in “Making calls with one-touch dialing” above.
- 2 Display “DIRECTORY” by pressing **(SELECT)**.
- 3 Display the name and phone number you want to call (see page 27), then press **(SELECT)** or **(TALK)**.

When you leave the Jog lever raised, or lowered, the names and phone numbers on the display scroll fast.

To check the phone number before one-touch dialing

While the handset is not in use, press **(ONE TOUCH)**.

The number stored on the button appears on the display for 20 seconds. To dial the number, press **(TALK)** while the number is displayed.

Phone Directory

You can dial a number by scrolling through the Phone Directory, in which up to 50 phone numbers can be stored.

Storing phone numbers and names

Example: to store “SONY” “123-4567”.

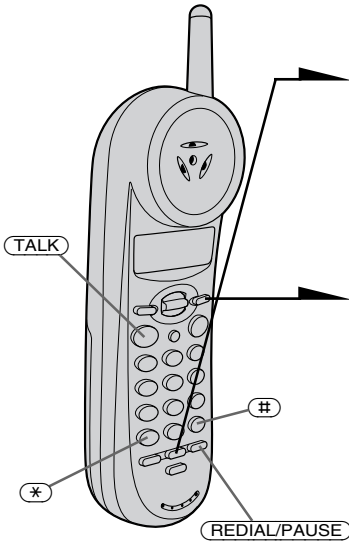

- 1 Press **PGM**.
(Be sure not to press **TALK**.)



- 2 Display “DIRECTORY” using the Jog lever, then press **SELECT**.
“ENTER NAME” appears.

- 3 Enter the name using the dialing keys. You can enter up to 15 characters.

Press a dialing key repeatedly until the desired character appears. (See the character table for details.)

Enter successive characters in the same way.

To enter two characters assigned to the same key, or to enter a “space”, raise the Jog lever to move the cursor to the right.

Example: to enter “SONY”, press **7** four times (S), press **6** three times (O), raise the Jog lever to move the cursor, press **6** twice (N), and press **9** three times (Y).

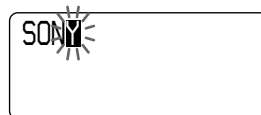

Character table

Key	Character
①	1
②	A → B → C → 2
③	D → E → F → 3
④	G → H → I → 4
⑤	J → K → L → 5
⑥	M → N → O → 6
⑦	P → Q → R → S → 7
⑧	T → U → V → 8
⑨	W → X → Y → Z → 9
⑩	0
*	*
#	& → ' → , → - → . → #

4 Press **(SELECT)**.

“ENTER NUMBER” appears.

5 Enter the phone number.

You can enter up to 16 digits, including a tone and a pause, each of which is counted as one digit.

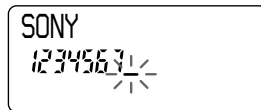

6 Press **(PGM)**.

You will hear a long confirmation beep, and the name and the number are stored. The display goes off.

Notes

- If you intend to save a 51st phone number, you will hear five short error beeps and “MEMORY FULL” will be displayed. You cannot store the phone number. To store another phone number, erase one of the stored phone numbers (see page 26).
- Do not allow more than 20 seconds to elapse between each step of the procedure.

Tips

- If you have entered a wrong name or number in step 3 or 5, lower the Jog lever to erase it. Then enter the correct name or number.
- The entered phone number **(*)** and **(#)** are displayed as “*” and “#” respectively in step 5.

To store a number to be dialed via Private Branch Exchange (PBX)

Before entering a phone number in step 5 above, do as follows:

1 Enter the outside line access digit (e.g., 9).

2 Press **(REDIAL/PAUSE)**.

Changing a stored name and/or phone number

1 Display the name and phone number you want to change by doing steps 1 and 2 on page 27.

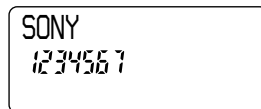

2 Press **(SELECT)**.



continued

Phone Directory (continued)

- 3 Make "EDIT" flash using the Jog lever, then press **(SELECT)**.
The cursor flashes at the last character of the name.
- 4 Lower the Jog lever to erase the characters and enter the new name.
If you want to change only the number, skip this step.
- 5 Press **(SELECT)**.
The cursor flashes at the last digit of the phone number.
- 6 Lower the Jog lever to erase the number and enter the new number.
If you don't want to change the number, skip this step.
- 7 Press **(SELECT)**.
You will hear a long confirmation beep and the name and/or the number is changed.

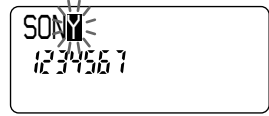

Erasing a memory location

- 1 Display the name and phone number you want to erase by doing steps 1 and 2 on page 27.
- 2 Press **(SELECT)**.
- 3 Make "ERASE" flash using the Jog lever, then press **(SELECT)**.
- 4 Make "YES" flash using the Jog lever, then press **(SELECT)**.
You hear a long confirmation beep and the memory location is erased.

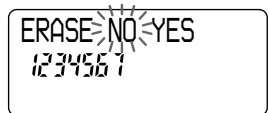
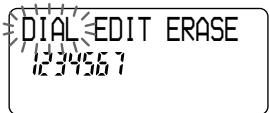
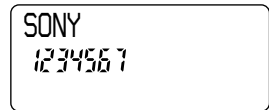

Making calls from the Phone Directory

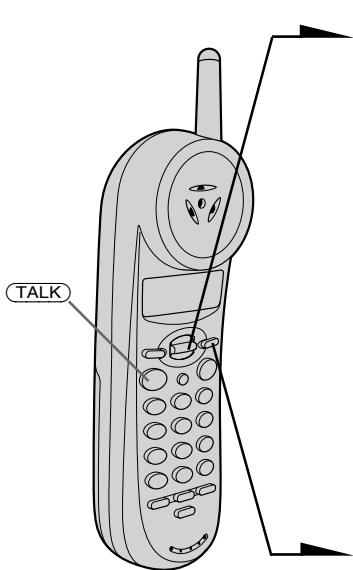

1 Raise the Jog lever.
“DIRECTORY” appears.

2 Display the name and phone number you want to call.

To search in alphabetical order:
Raise or lower the Jog lever.

To search by entering the initial character:
Press the dialing key of the desired character, then lower the Jog lever.

SONY
1234567

3 Press (SELECT).

DIAL EDIT ERASE
1234567

4 Press (SELECT) again.

The phone number will be dialed.

Tip

You may press (TALK) to make a call instead of pressing (SELECT) in steps 3 and 4.

About the search order

The names appear in the following order when you raise or lower the Jog lever.

- Alphabetical order: ABC...XYZ ↔ symbols ↔ * ↔ # ↔ 0 - 9

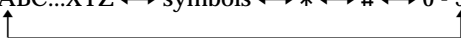

- Initial character: To search for “SONY” for example, press (7) and then lower the Jog lever to search through the names starting with S.

Setting the ringer type

You can select a ringer type of the handset from four types.

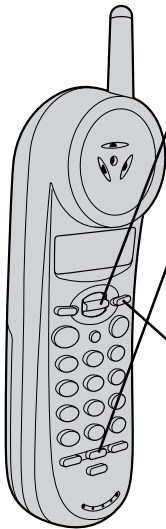

- 1 Press **PGM**.
- 2 Display "RINGER" using the Jog lever.

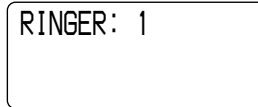

The current ringer type appears.

- 3 Press **SELECT**.
- 4 Select a ringer type ("1" to "4") using the Jog lever.
- 5 Press **PGM**.

You will hear the corresponding ringer tone.

Tip

You may press **SELECT** instead of pressing **PGM** in step 5.

Turning off the ringer of the handset

- 1 Perform steps 1 to 3 in "Setting the ringer type" above.
- 2 Select "OFF" using the Jog lever.
- 3 Press **PGM**.

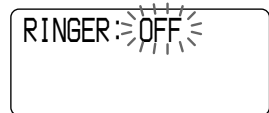

You will hear a long confirmation beep.

Tip

You may press **SELECT** instead of pressing **PGM** in step 3.

When "RINGER" is set to "RINGER OFF"

The handset won't ring. You can still make calls, and also receive calls if another telephone connected to the same line rings to inform you on incoming calls.

To turn the ringer on again

Follow the instructions described in "Setting the ringer type" above.

Locating the handset

You can page the handset from the base unit.

Note that you cannot page if the handset is in use.

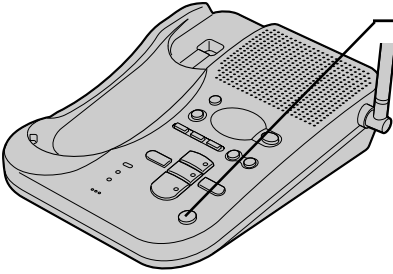

Press **HANDSET LOCATOR**.

The handset rings for about one minute.

To stop ringing, press **OFF** on the handset.

Tip

You can page the handset even when "RINGER" is set to "RINGER OFF".

Setting up the answering machine

Setting the time and day of the week

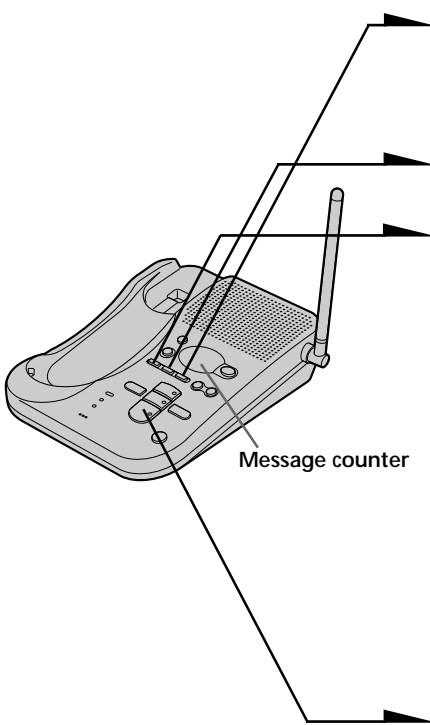

- 1** Press **(MENU)** repeatedly until you hear “Set day and time”. “- -” blinks on the message counter.
- 2** Press **(SELECT)** repeatedly to select the day of the week.
- 3** Press **(TIME/SET)**. The day is set and the hour is announced.
- 4** Press **(SELECT)** repeatedly to select the hour.
- 5** Press **(TIME/SET)**. The hour is set and the minute is announced.
- 6** Press **(SELECT)** repeatedly to select the minute.
- 7** Press **(TIME/SET)**. The day and time you just entered is announced.
- 8** Press **(PLAY/STOP)** to exit the menu setup mode. You will hear a long confirmation beep and the clock restarts.

Notes

- Press and hold **(SELECT)** to increase the minute setting by 10.
- The time and day are preset to Monday, 12:00 AM.
- “CL” flashes when the day and time is cleared or delayed due to a power interruption, or when you connect the base unit to the AC outlet for the first time.

Tip

All the mailbox buttons (**(MAILBOX 1)**, **(MAILBOX 2)** and **(MAILBOX 3)**) work as the **(PLAY/STOP)** button; press any of the three in this case.

To hear the current time

Press **(TIME/SET)**.

The current time setting is announced.

Recording the greeting

You can record your own greeting for the “normal” and “announcement only” modes (see page 39).

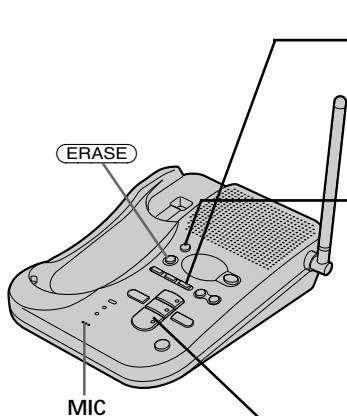

- 1 Press **(MENU)** repeatedly until “Set out-going message” is announced. “- -” blinks on the message counter.
- 2 Press **(REC/MEMO)**. “Now recording” is announced and a long beep sounds.
- 3 Speak into the base unit microphone (MIC). The message counter starts counting. You can record up to 90 seconds.
- 4 To stop recording, press **(PLAY/STOP)**. Your greeting replays automatically.

Notes

- If you do not record your own greeting, the prerecorded greeting will be assigned automatically.
- If your greeting is less than two seconds, the greeting is not recorded. The prerecorded greeting will be assigned automatically.
- If a call comes in during recording, recording stops automatically.
- If 90 seconds have passed or memory becomes full in step 3, recording stops automatically.
- “Memory full” is announced if no recording space is available when you press **(REC/MEMO)**. Erase unnecessary messages (see page 38).

Tip

To record a greeting for the “announcement only” mode, select the announcement only mode first (see page 39), then follow the instructions above. Otherwise, the normal greeting will be recorded.

continued

Setting up the answering machine (continued)

To check the greeting

Press **(MENU)** repeatedly until “Set out-going message” is announced.
Then press **(PLAY/STOP)** to play back the greeting.

To change the greeting

Record a new greeting by following the instructions on page 31. The new greeting replaces the old one.

To erase the greeting

- 1 Press **(MENU)** repeatedly until “Set out-going message” is announced.
- 2 Press **(ERASE)**.

Notes

- You can also erase the greeting during playback.
- If you have erased your own greeting, the prerecorded greeting will be assigned automatically.

Prerecorded greetings

Normal mode:

“Hello, I’m unable to answer your call right now. Please leave your name, number and message after the tone.”

Announcement only mode:

“Hello, I’m unable to answer your call right now. Please call again. Thank you.”

Setting the number of rings

You can select the number of times the phone rings before it answers to take a message.

There are four modes: 2, 4, 6, and Toll Saver.

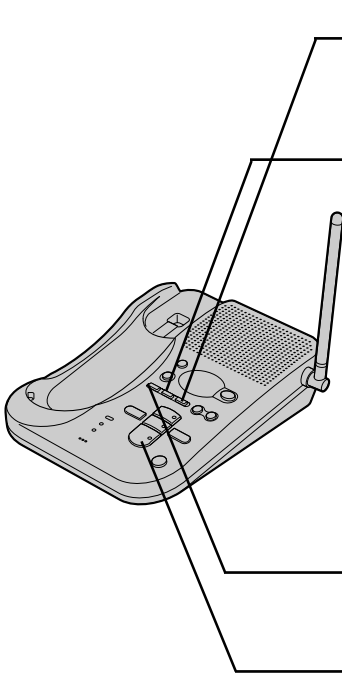

1 Press **MENU** repeatedly until you hear “Set number of rings”. “- -” blinks on the message counter.

2 Press **SELECT** repeatedly to select a ring duration (2, 4, 6, or Toll Saver).

To answer after 2 rings, select “2”.

To answer after 4 rings, select “4”.

To answer after 6 rings, select “6”.

Select “Toll Saver” to answer after 2 rings when there are new messages, and 4 rings where there are no new messages.

3 Press **TIME/SET**. The ring duration setting is announced.

4 Press **PLAY/STOP** to exit the menu setup mode.

Notes

- When the number of rings is set to “Toll Saver”, the phone answers after 2 rings if new messages are recorded. If no new messages are recorded, it answers after 4 rings. When you hear 3 rings, you will know that there are no new messages. You can save the toll for the call when you pick up messages from an outside phone.
- The number of rings is preset to 4 rings.

continued

Setting up the answering machine (continued)

Setting the audible message alert

You have the option of having a beep tell you if you have received any new incoming messages.

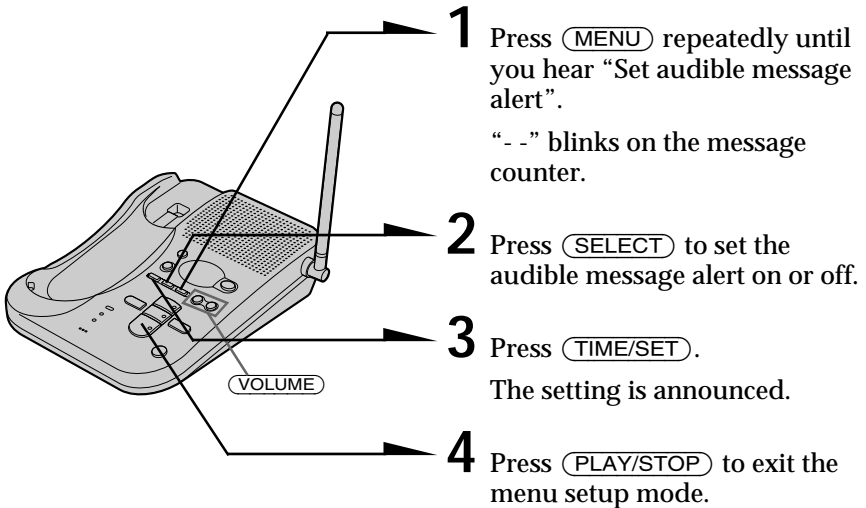

Notes

- When the audible message alert is turned on, you will hear a beep every 10 seconds if there are any new messages.
- To stop the beep, press any button related to the answering machine function or **VOLUME** **+** / **-**.
- The audible message alert is preset to off.

Turning on the answering function

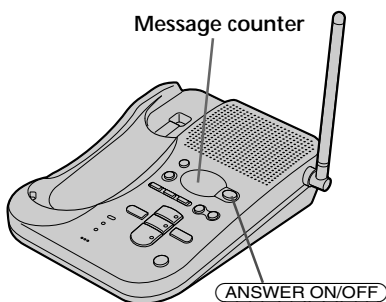

Press **ANSWER ON/OFF** on the base unit.
The ANSWER ON/OFF button lights up.

Mailbox usage

This phone offers you three voice mailboxes, providing a convenient way to share the mailbox feature with other members of your household or business.

When a caller calls

The caller can choose one of the two ways to leave a message:

- If calling from a touch-tone phone, the caller selects a mailbox by pressing *** 1** (MAILBOX 1), *** 2** (MAILBOX 2) or *** 3** (MAILBOX 3) while he or her hears the greeting. The greeting stops and a beep will sound, then the caller can start recording a message.
- Wait until the greeting finishes, then start recording a message. When the caller does not select a mailbox, the message is automatically recorded to MAILBOX 1.

Notes

- If four minutes have passed while recording the incoming message, the line will be disconnected automatically.
- If the message is shorter than two seconds, it will not be recorded.

To turn off the answering function

Press **ANSWER ON/OFF** on the base unit.

The ANSWER ON/OFF button goes off.

Note

The answering function is preset to on.

Tip

The answering machine will automatically answer a call after 10 rings, even if the answering function is off and announces "Please enter your security code" to prompt the caller to turn on the answering function.

continued

Setting up the answering machine (continued)

When the memory is full

The total recording time of this answering machine is approximately 15 minutes (including the greeting, messages, and memo).

When the remaining recording time becomes less than 30 seconds, "F" flashes on the message counter and the answering machine goes into the memory full status.

In this status, the answering machine will not answer a call until after 10 rings even if the answering function is on.

To avoid this erase unnecessary messages (see page 38). You can also erase the messages from an outside phone (see page 44).

Playing back messages

If there are new messages, the message counter flashes the number of new messages.

You will hear beeps if the audible message alert setting is on (see page 34).

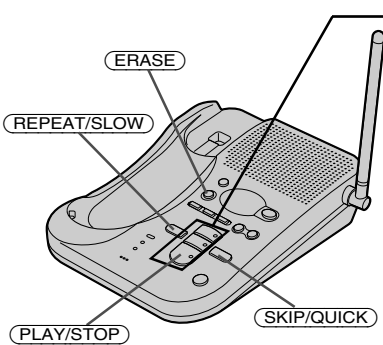

Press a mailbox button (**MAILBOX 1**), (**MAILBOX 2**) or (**MAILBOX 3**) to play back new messages in the selected mailbox.

Additional tasks when playing back messages

To	Do this
Stop playback	Press a mailbox button (MAILBOX 1), (MAILBOX 2) or (MAILBOX 3).
Repeat the current message	Press REPEAT/SLOW during play back.
Skip the current message	Press SKIP/QUICK .
Go back to the previous message	Press REPEAT/SLOW within the first two seconds of the current message playback.
Play back slowly	Press and hold REPEAT/SLOW during play back. Release REPEAT/SLOW to return to normal.
Play back quickly	Press and hold SKIP/QUICK during play back. Release SKIP/QUICK to return to normal.

Notes

- If a call comes in, the play back will stop.
- A time and day stamp is announced after each message.

Tips

- If there are no new messages, all the previously reviewed messages are played back.
- The messages are saved even after a power failure.

continued

Playing back messages (continued)

Adjusting the speaker volume

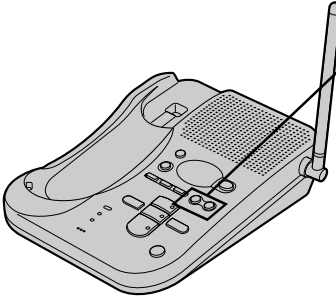

To adjust the speaker volume, press **(VOLUME +)** or **(-)**.

Notes

- When you have reached the minimum or maximum volume level, you will hear three short beeps.
- You cannot adjust the speaker volume while the phone is ringing.

Tip

There are 8 steps for the volume level (1 to 8). The volume level is preset to 5.

Erasing messages

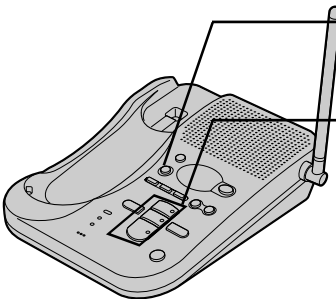

- 1** Press and hold **(ERASE)** for more than two seconds.
- 2** Press a button for the mailbox you want to erase (**(MAILBOX 1)**, **(MAILBOX 2)** or **(MAILBOX 3)**). You will hear a long confirmation beep and all “old” messages in the selected mailbox are erased.

To erase individual messages

Press **(ERASE)** while playing back the message that you want to erase.

Note

The display shows the total number of “new” (i.e. unreviewed) messages. Therefore, the message counter is reset to “0” when you have played back all new messages, whether they have been erased or not. Be sure to erase unnecessary messages before the memory becomes full.

Selecting the Announcement Only Mode

You can set the answering machine to play the greeting without recording incoming messages (announcement only mode). You might want to select this mode when, for example, you expect to be away for a while and you cannot pick up messages.

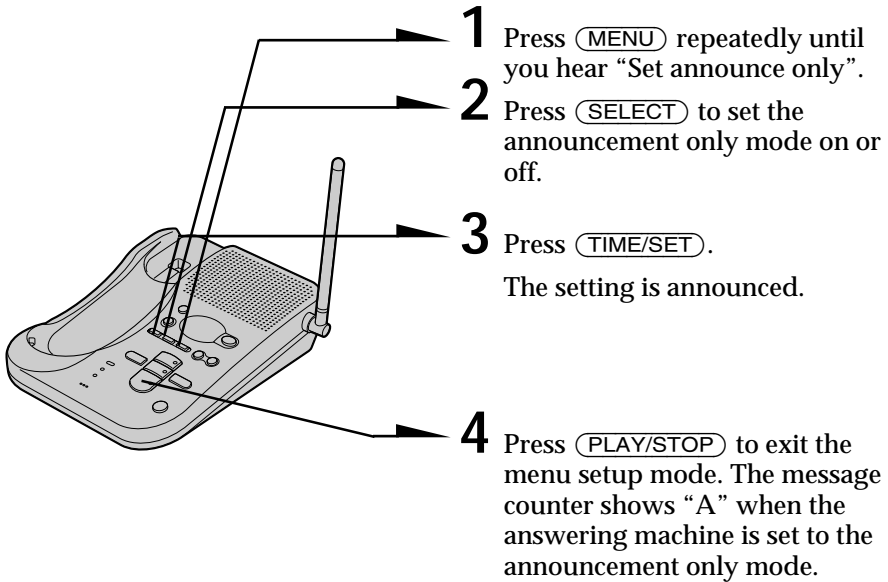

Notes

- To activate announcement only mode, you have to turn on the answering machine.
- The announcement only mode is preset to off.

Screening calls

You can screen calls by leaving the answering machine on while you are at home. When a call is answered, you can hear the message being recorded through the base unit. You can decide either to continue recording or to answer the call.

The message will be recorded, but to hear it you will need to play back the message (see page 37).

To answer the call

Press **TALK** on the handset.

Notes

- Press **VOLUME** **+** or **-** to adjust the speaker volume. If the speaker volume is set at its minimum level, you will not be able to hear incoming calls.
- The answering machine will stop automatically when the handset or a parallel phone is picked up. If the answering machine does not stop, press either **PLAY/STOP** on the base unit, or *** 0** on the handset or parallel phone.
The recording will remain as a new message.

Recording a memo message

You can leave messages for other users of the unit.

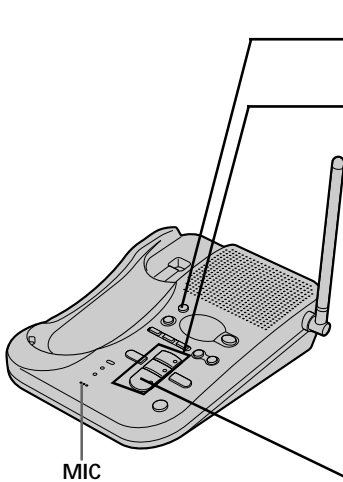

1 Press **REC/MEMO**.

2 Press a mailbox button (**MAILBOX 1**, **MAILBOX 2** or **MAILBOX 3**) to which you want to leave the message.

“Now recording” is announced and counting starts.

3 Speak into the base unit microphone (MIC) to record your message.

A memo can be up to four minutes in length.

4 Press **PLAY/STOP** to stop recording.

The message number on the display increases by one.

Notes

- If the memory becomes full, the answering machine will stop recording.
- “Memory full” is announced if no recording space is available when you press **REC/MEMO**.
- If your message is shorter than two seconds, the recording will be canceled.
- The message counter flashes “99” if you record a memo for more than 99 seconds.
- If a call comes in during recording, the recording will be stopped.

Operating from an outside phone

Setting the remote ID code (security code)

To operate the answering machine from a touch-tone phone while you are away from home, you need to set the remote ID code (security code).

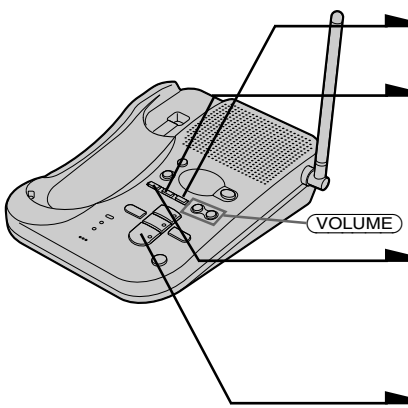

- 1 Press **(MENU)** repeatedly until you hear “Set security code”.
- 2 Press **(SELECT)** to change the remote ID code (security code) setting.
- 3 Press **(TIME/SET)** to confirm your choice.
The new remote ID code (security code) is announced.
- 4 Press **(PLAY/STOP)** to exit the menu setup mode.

Note

Press and hold **(SELECT)** to increase the remote ID code (security code) by 10.

Picking up new messages

- 1 Call your telephone number from a touch-tone phone.
- 2 When you hear the greeting, press (#) and enter your remote ID code (security code).
You will hear a long confirmation beep.
The number of new messages will be announced.
- 3 Press the keys in the “Table of control codes” (see page 44) for the desired operation command.
- 4 When you are finished, disconnect the line.

Notes

- Do not let two seconds elapse between each digit of the remote ID code (security code) and the control code.
- If you did not turn on the answering machine, your phone answers automatically after 10 rings.
- If the message recording memory runs out, the answering machine turns off automatically. “Memory full. Please enter your security code” is announced.
- If you enter wrong remote ID code (security code) three times, the line will be disconnected.
- If no keys are pressed within 20 seconds, the line will be disconnected.

Tips

- Press (*) (0) on the touch-tone keypad or (PLAY/STOP) on the base unit to disconnect the line.
- Cut off the Remote Control Card and carry it with you to see how to operate from an outside phone.

continued

Operating from an outside phone (continued)

Table of control codes

To	Key	Notes
Play back messages in MAILBOX 1	# ①	Plays back from the first new message.
Play back messages in MAILBOX 2	# ②	Plays back from the first new message.
Play back messages in MAILBOX 3	# ③	Plays back from the first new message.
Repeat/skip backward	# ④	Press during play back to repeat a message. To skip backward, press within two seconds after the current message starts.
Get help	* ⑤	Press to access simple voice menu. Press again to access advanced voice menu.
Stop operation	# ⑤	Stops every function.
Skip forward	# ⑥	Press during play back to skip forward.
Record greeting	* ⑦	"Now recording" is announced.
Check greeting	# ⑦	Review your greeting.
Record a memo	* ⑧	Select the mailbox by entering "1", "2" or "3".
Erase individual messages	# ⑨	Press during play back.
Turn answering machine on/off	# ⑩	Turns the system on/off. "Answer machine on" or "Answer machine off" is announced.

Understanding the Caller ID service

Caller ID allows the caller's phone number to be shown on the display before the call is answered. In order to use this feature, you must first subscribe to the Caller ID service. The name of this service may vary depending on your telephone company.

When you receive a call

The phone number appears on the display with the date and time as shown in the following example.

If your Caller ID service includes the caller name service, the caller's name also appears on the display (up to 15 letters).

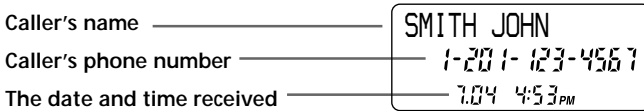

When you answer the call, the Caller ID display changes to the "TALK" display.

Note

If the call is from an office which uses multiple lines, the displayed phone number may not match the number you use to call the extension.

Tip

Even if the ringer of the handset is set to "RINGER OFF", you can receive Caller ID data.

Looking at the Caller ID list

The phone stores the data of the last 50 calls received. It keeps track of all calls received; even if they were not answered.

Viewing the Caller ID list

You can look through the Caller ID list to check the phone number and/or name of the calls received.

While the handset is not in use the display shows the number of “NEW” (calls which you have not viewed) and “OLD” (calls which you have viewed) calls. If there is a “NEW” data, the NEW CALL lamp of the base unit flashes.

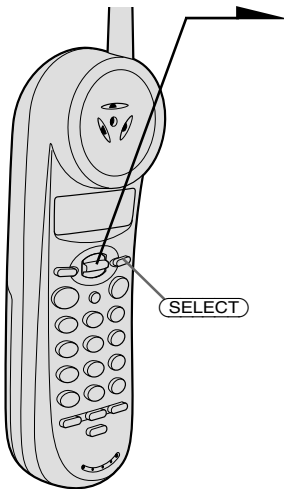
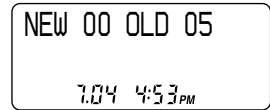

- 1** Lower the Jog lever.
Data for the newest call appears for 20 seconds.
- 2** Lower the Jog lever to display older data or raise to display newer data.

NEW CALL lamp

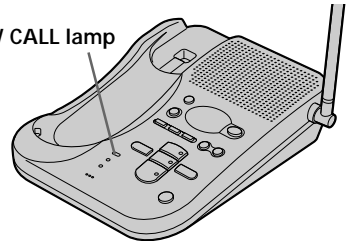

Note

If a 51st call is received, the oldest data is automatically erased.

About the “*” mark

“*” appears if there are two or more calls in a row from the same phone number. The older data will be replaced by the new data, so the calls are counted as only one call.

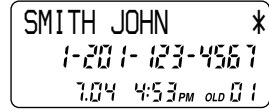

Erasing data from the Caller ID list

Old data will be erased automatically when a 51st call comes in, but you can also manually erase unnecessary data one by one or erase the entire list.

To erase the phone number one by one

1 Display the phone number you want to erase from the Caller ID list (see page 46).

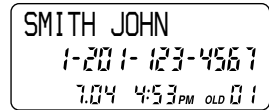

2 Press **(SELECT)**.

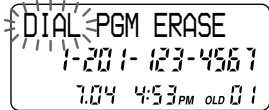

3 Make “ERASE” flash using the Jog lever, then press **(SELECT)**.

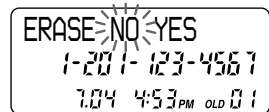

4 Make “YES” flash using the Jog lever, then press **(SELECT)**.

You will hear a long confirmation beep and the data is erased.

continued

Looking at the Caller ID list (continued)

To erase the entire list at once

You can erase the entire list at once only when all the data has become "OLD" data. If there is any "NEW" data, you cannot erase the entire list.

- 1 Display any Caller ID data.

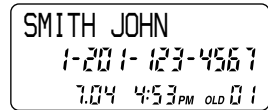

- 2 Press **SELECT**.

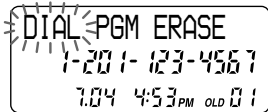

- 3 Make "ERASE" flash using the Jog lever, then press **SELECT**.

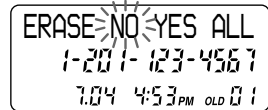

- 4 Make "ALL" flash using the Jog lever, then press **SELECT**.

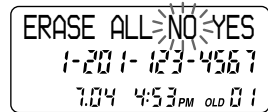

- 5 Make "YES" flash using the Jog lever, then press **SELECT**.

You will hear a long confirmation beep and the entire list is erased.

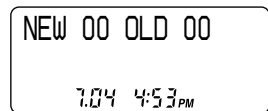

Using the Caller ID list

By using the Caller ID list, you can call back a phone number from the Caller ID list easily, or store numbers from the Caller ID list into the Phone Directory.

Calling back a number from the Caller ID list

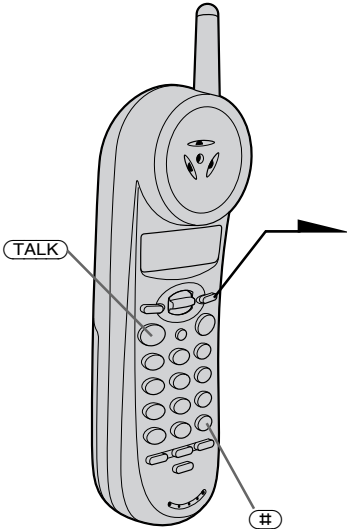

- 1 Display the phone number you want to call from the Caller ID list (see page 46).

SMITH JOHN
1-201-123-4567
7:04 4:53 PM NEW 08

- 2 Confirm the number and press **(SELECT)**.

DIAL PGM ERASE
1-201-123-4567
7:04 4:53 PM NEW 08

- 3 Make "DIAL" flash using the Jog lever, then press **(SELECT)**.
The phone automatically dials the displayed number.

Notes

- If the number displayed in step 1 is not the one you should call back, you can change the number of digits of the phone number (see page 51).
- If the phone is connected to a Private Branch Exchange (PBX), you may not be able to call back from the Caller ID list because an outside line access digit is necessary.

Tip

You may press **(TALK)** to make a call instead of pressing **(SELECT)** in steps 2 and 3.

Using the Caller ID list (continued)

Storing a number of the Caller ID list into the Phone Directory

- 1 Display the name and phone number you want to store from the Caller ID list (see page 46).

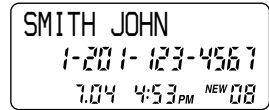

- 2 Confirm the number and press **(SELECT)**.

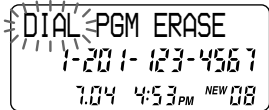

- 3 Make "PGM" flash using the Jog lever, then press **(SELECT)**.

The cursor flashes at the end of the name.

Enter or change the name, if necessary (see page 25).

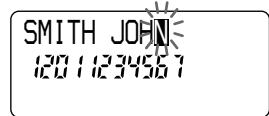

- 4 Press **(SELECT)**.

The cursor flashes at the right of the phone number.

Enter or change the phone number, if necessary (see pages 25 and 26).

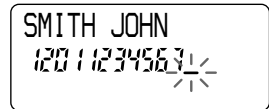

- 5 Press **(SELECT)** again.

You will hear a long confirmation beep and the name and number are stored.

Notes

- Do not allow more than 20 seconds to elapse between each step of the procedure.
- If the number displayed in step 1 is not the one you should store, you can change the number of digits of the phone number (See page 51).
- If the phone is connected to a Private Branch Exchange (PBX), you may need to add an outside line access digit.

To change the number of digits of the phone number

If the number of digits of the phone number in the Caller ID list is different from the actual phone number, you need to adjust the number of digits of the phone number to call back or store into the Phone Directory.

- 1 While the phone number from the Caller ID list is displayed, press **(#)** repeatedly until the phone number with the correct number of digits appears on the display.

Each time you press **(#)**, the number of digits changes as follows.

When you receive the 11 digits phone number

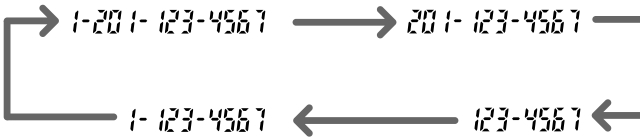

When you receive the 10 digits phone number

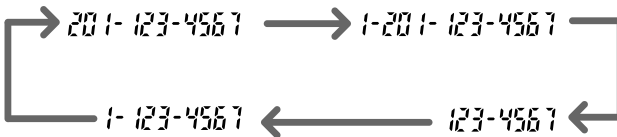

continued

Using the Caller ID list (continued)

When you receive the 8 digits phone number

2 1234567 ← → 12 1234567

When you receive the 7 digits phone number

123-4567 ← → 1- 123-4567

2 Continue the operation to call back or store the phone number with the correct number of digits (see pages 49 and 50).

Notes

- The number of digits of the phone number does not change even if you press **(#)** when you receive the phone number of 6 digits or less.
- You need to adjust the number of digits each time you call back from the Caller ID list as the changes to the Caller ID data is not stored in memory.
- You may not be able to change the number of digits depending on the Caller ID data.

Using “Caller ID with call waiting” service

This telephone is compatible with the “Caller ID with call waiting” service. Make sure that your telephone company offers this service.

Like the basic Caller ID service, you need to subscribe to “Caller ID with call waiting” in order to use this service.

Even though you may have already subscribed to “Caller ID” and “call waiting” as two separate services, you need to request a subscription to “Caller ID with call waiting” as a single service.

This is a new service that combines the two services.

Even though you now have a “Caller ID with call waiting” compatible phone, unless you subscribe to the combined “Caller ID with call waiting” service, you will not be able to see the name and number of the second caller.

When a new call comes in while you are talking, you hear two short beeps. The caller’s name and/or phone number of the new call appears on the display for about 20 seconds.

To switch to another caller

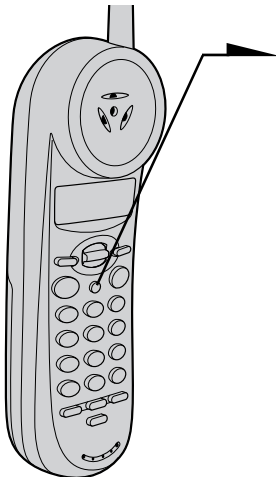

- 1** To switch to the new caller, press **FLASH**.
- 2** To switch back to the first caller, press **FLASH** again.

Mounting the base unit on a wall

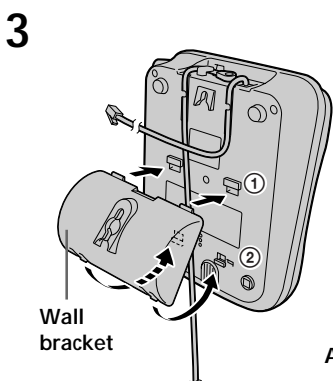
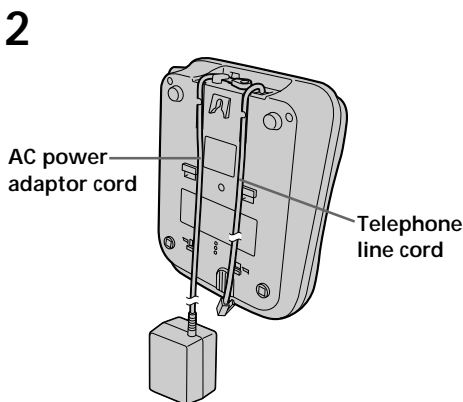
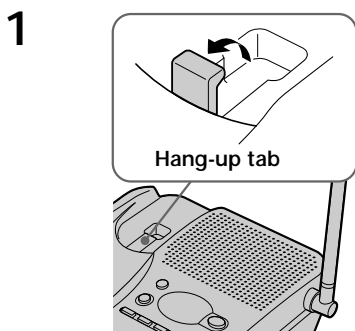

1 Raise the hang up tab.

2 Plug the telephone line cord to the LINE jack and the AC power adaptor to the DC IN 9V jack, and hook the cords.

3 Attach the wall bracket to the center of the base unit. Align the Δ marks of the wall bracket with those of the base unit.

4 Plug the telephone line cord to the telephone outlet, and hook the base unit to the wall plate.

5 Plug the AC power adaptor to an AC outlet. Then raise the antenna so that it points towards the ceiling.

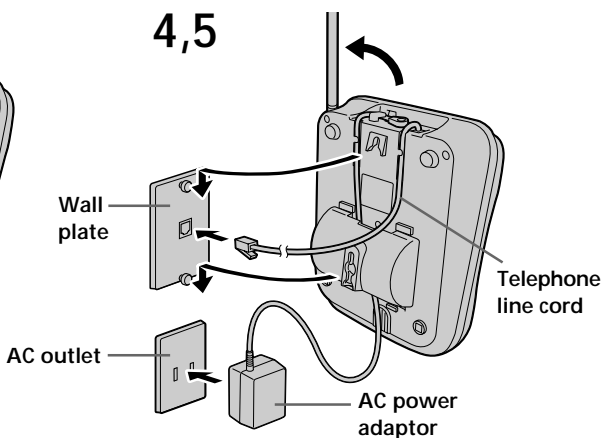

Tip
To remove the wall bracket, press the lower tabs.

Carrying the handset by the belt clip

You can hang the handset on the belt by attaching the belt clip to the handset.

Attaching the belt clip

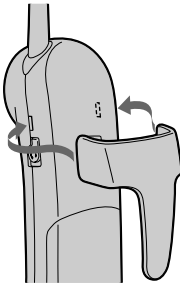

Press the belt clip to the handset. Make sure that the side tabs click and go into the holes on the sides of the handset.

Note

To prevent the handset from dropping, make sure that each tab is completely inserted.

Detaching the belt clip

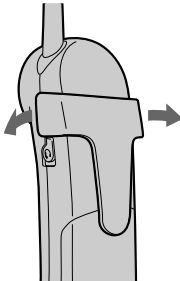

While pressing the back of the belt clip, pull the sides one by one until the tabs come off from the holes.

Note

Remove the belt clip carefully to avoid breaking your fingernails.

Carrying the handset by the belt clip (continued)

Using the headset

You can talk on the cordless handset without using your hands by connecting a headset (optional) to the  (HEADSET) jack on the handset.

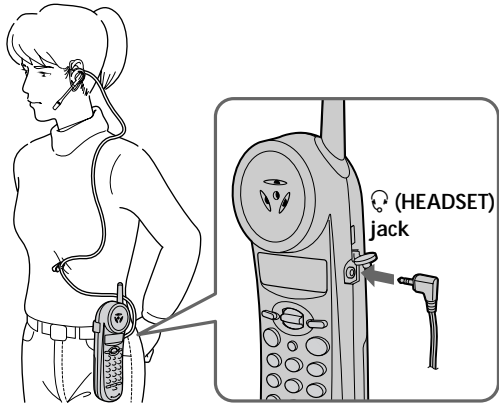

Notes on power sources

On battery pack

- Store the battery pack at a temperature between 41°F (5°C) and 95°F (35°C) for best performance.
- If you do not use the handset for a long period of time, remove the battery pack after charging for more than 12 hours. This maintains battery life.

On power failure

During a power interruption, you cannot make or receive calls, and you cannot use the answering machine.

For the customers in the USA

RECYCLING NICKEL-CADMIUM BATTERIES

Nickel-Cadmium batteries are recyclable. You can help preserve our environment by returning your unwanted batteries to your nearest point for collection, recycling or proper disposal.



Note: In some areas the disposal of nickel-cadmium batteries in household or business trash may be prohibited.

RBRC (Rechargeable Battery Recycling Corporation) advises you about spent battery collection by the following phone number.

Call toll free number: 1-800-822-8837
(United States and Canada only)

Caution: Do not handle damaged or leaking nickel-cadmium batteries.

Maintenance

- Clean the cabinets with a soft cloth slightly moistened with water or a mild detergent solution. Do not use any type of abrasive pad, scouring powder or solvent such as alcohol or benzine as they may damage the finish of the cabinet.
- If the charge terminals of the base unit and handset are soiled, wipe them with a soft cloth.

If you have any questions or problems concerning your phone, please consult your nearest Sony dealer.

Troubleshooting

If you've experienced any of the following difficulties while using your phone, use this troubleshooting to help you remedy the problem. Should any problem persist, consult your nearest Sony dealer.

	Symptom	Remedy
Making calls	You hear five short error beeps when you press TALK .	<ul style="list-style-type: none"> • Make sure you set up the base unit correctly (page 6). • Move the handset closer to the base unit.
	You hear no dial tone.	<ul style="list-style-type: none"> • Make sure the telephone line cord is securely connected to the telephone outlet. • Make sure the battery is fully charged (page 9).
	The phone does not connect at all, even though the number you dial is correct.	<ul style="list-style-type: none"> • Make sure the dialing mode is set correctly (page 12).
	The phone does not redial correctly.	<ul style="list-style-type: none"> • Make sure the last dialed number is really the one you want to dial.
	You hear five short error beeps when you try to redial.	<ul style="list-style-type: none"> • The number you last dialed exceeds 32 digits (including the tone and pause digits if used). • The number you last dialed is erased.
	You cannot perform the redial operations (redialing, checking and erasing the phone number), and "NO CONNECT" appears on the display.	<ul style="list-style-type: none"> • Move the handset closer to the base unit and perform the redial operations again.
Receiving calls	The handset does not ring.	<ul style="list-style-type: none"> • Make sure the ringer is turned on. • The battery may be weak. Charge the battery for more than 12 hours (page 9). • Make sure you set up the base unit correctly (page 6). • Move the handset closer to the base unit.
	"NO LINE" appears on the display.	<ul style="list-style-type: none"> • Make sure the telephone line cord is securely connected to the telephone outlet.
During conversation	You hear interference during conversation.	<ul style="list-style-type: none"> • Move the handset closer to the base unit. • Place the base unit away from noise sources (page 6).
	Your conversation is muted and "NO CONNECT" appear on the display.	<ul style="list-style-type: none"> • This is the out-of-range alarm. Move the handset closer to the base unit within one minute.
	You hear a beep every three seconds and BATTERY LOW appears on the display.	<ul style="list-style-type: none"> • The battery is weak. Charge the battery for more than 12 hours (page 9).

continued

Troubleshooting (continued)

	Symptom	Remedy
Phone Directory	You hear five short error beeps and cannot store a number in the Phone Directory.	<ul style="list-style-type: none"> • Make sure you follow the procedure in storing the number correctly (page 24). • Make sure the number (including the tone and pause digits) does not exceed 16 digits.
	Phone Directory dialing is incorrect.	<ul style="list-style-type: none"> • Store a correct number (page 24).
Answering machine	No sound from the speaker of the base unit.	<ul style="list-style-type: none"> • Adjust the speaker volume.
	Message is not recorded.	<ul style="list-style-type: none"> • The remaining recording time is less than 30 seconds or 99 messages were recorded. The answering machine becomes "Memory full" status and does not record messages. Erase messages (page 38). • The message is less than two seconds. The answering machine does not record messages less than two seconds in length.
Operating from an outside phone	A long confirmation beep does not sound when you enter your remote ID code (security code).	<ul style="list-style-type: none"> • Enter your remote ID code (security code) while the greeting is being played back. • Make sure you are calling from a touch-tone phone.
Caller ID	The caller's name and/or phone number does not appear on the display.	<ul style="list-style-type: none"> • Make sure you have subscribed to Caller ID service. • Caller ID service may not work when the phone is connected to a Private Branch Exchange (PBX). • You answered the call while "** RINGING **" was displayed. Be sure to answer after the Caller ID data is displayed.
	The caller's name and/or phone number does not appear on the display during call waiting.	<ul style="list-style-type: none"> • Make sure you have subscribed to "Caller ID with call waiting" service (page 53). • Make sure nobody is talking with another phone on the same telephone line.
	You cannot dial the number from the Caller ID list.	<ul style="list-style-type: none"> • You may need to change the number of digits of the phone number (page 51). • This function may not work when the phone is connected to a Private Branch Exchange (PBX).

	Symptom	Remedy
Power source/battery	The CHARGE lamp does not light up when you place the handset to charge.	<ul style="list-style-type: none"> Wipe the charge terminals of the base unit and the handset with a soft cloth for better contact of the charge terminals. Make sure the handset is placed on the base unit properly.
	The CHARGE lamp flashes.	<ul style="list-style-type: none"> The battery is empty. Charge the battery for more than 12 hours (page 9).
	The battery duration is short.	<ul style="list-style-type: none"> The battery pack was charged less than 12 hours (due to power failure, etc.). The usage life of the battery has expired and needs replacement.

Message counter

The message counter on the base unit shows the following information.

When the counter shows	It means
Flashing number	Number of messages not yet played back.
CL	Flashes when the day and time is cleared or delayed due to a power interruption, or when you connect the base unit to the AC outlet for the first time. Reset the time correctly (page 30).
A	The announcement only mode is selected (page 39).
F	The recording area is full. Erase unnecessary messages (page 38).

Specifications

General

- Frequency band
902 - 928 MHz
- Operating channel
30 channels
- Dial signal
Tone, 10 PPS (pulse) selectable
- Supplied accessories
 - AC power adaptor AC-T122
 - Telephone line cord
 - Rechargeable battery pack BP-T18
 - Belt clip
 - Wall bracket

Handset

- Power source
Rechargeable battery pack BP-T18
- Battery life
 - Standby: Approx. 7 days
 - Talk: Approx. 7 hours
- Dimensions
 - Approx. 2 1/4 x 1 7/8 x 7 1/4 inches (w/h/d), antenna excluded (approx. 55 x 47 x 183 mm)
 - Antenna: Approx. 1 3/8 inches (approx. 34 mm)
- Mass
Approx. 7.7 oz (approx. 220 g), battery included

Base unit

- Power source
DC 9V from AC power adaptor AC-T122
- Battery charging time
Approx. 12 hours
- Dimensions
 - Approx. 6 3/4 x 2 1/4 x 7 1/2 inches (w/h/d), antenna excluded (approx. 171 x 57 x 189 mm)
 - Antenna: Approx. 6 1/8 inches (approx. 153 mm)
- Mass
Approx. 15 oz (approx. 412 g), wall bracket excluded

Answering machine

- Maximum recording time
Approx. 15 minutes, using incorporated IC
- Greeting message
Up to 90 seconds per each
- Incoming Memo message
Up to 4 minutes per message

Design and specifications are subject to change without notice.

Index

A

- Adjusting volume
 - handset 18
 - speaker 38
- Announcement only 39
- Answering machine
 - turning on 35
- Audible message alert 34

B

- Battery pack
 - charging 9
 - duration 10

C

- Call waiting service 18, 21
- Caller ID 45
 - Caller ID list 46
 - calling back 49
 - storing in Phone Directory 50
- Caller ID with call waiting 53
- Carrying the handset by the belt clip 56
- Connection 7
- Control codes for remote operations 44

D

- Date and time setting 13
- Dialing mode
 - choosing 12
 - switching to the tone temporarily 18
- Directroy
 - Phone Directory 24

E, F

- Erasing
 - Caller ID data 47
 - last phone number dialed 20
 - messages 38
 - Phone Directory 26

G, H

- Greeting 31

I, J, K

- Identifying the parts 14

L

- Language of the display 11
- Locating the handset 29
- Location, base unit 6

M, N

- Mailbox 35, 37
- Making calls 18
- Memo 41
- Messages 37
- Mounting the base unit on a wall 54

O

- One-touch dialing 22
- Operating from an outside phone 42
- OUT OF AREA 45

P, Q

- Phone Directory 24
- Playing
 - announcement only 39
 - messages 37
- PRIVATE 45
- Pulse dialing 12

R

- Recording
 - greeting 31
 - memo 41
- Receiving calls 21
- Redialing 20
- Remote ID code (security code) 42
- Ringer 28

S

- Screening calls 40
- Setting up
 - base unit 6
 - handset 9
- Speaker 38
- Stamping messages with day and time 30
- Storing Caller ID data in Phone Directory 50

T, U

- Table of control codes 44
- Time and date stamp 30
- Toll-saver feature 33
- Tone dialing
 - dialing mode 12
 - switching to 18
- Troubleshooting 59

V, W, X, Y, Z

- Volume
 - handset 18
 - speaker 38

For the customers in the USA

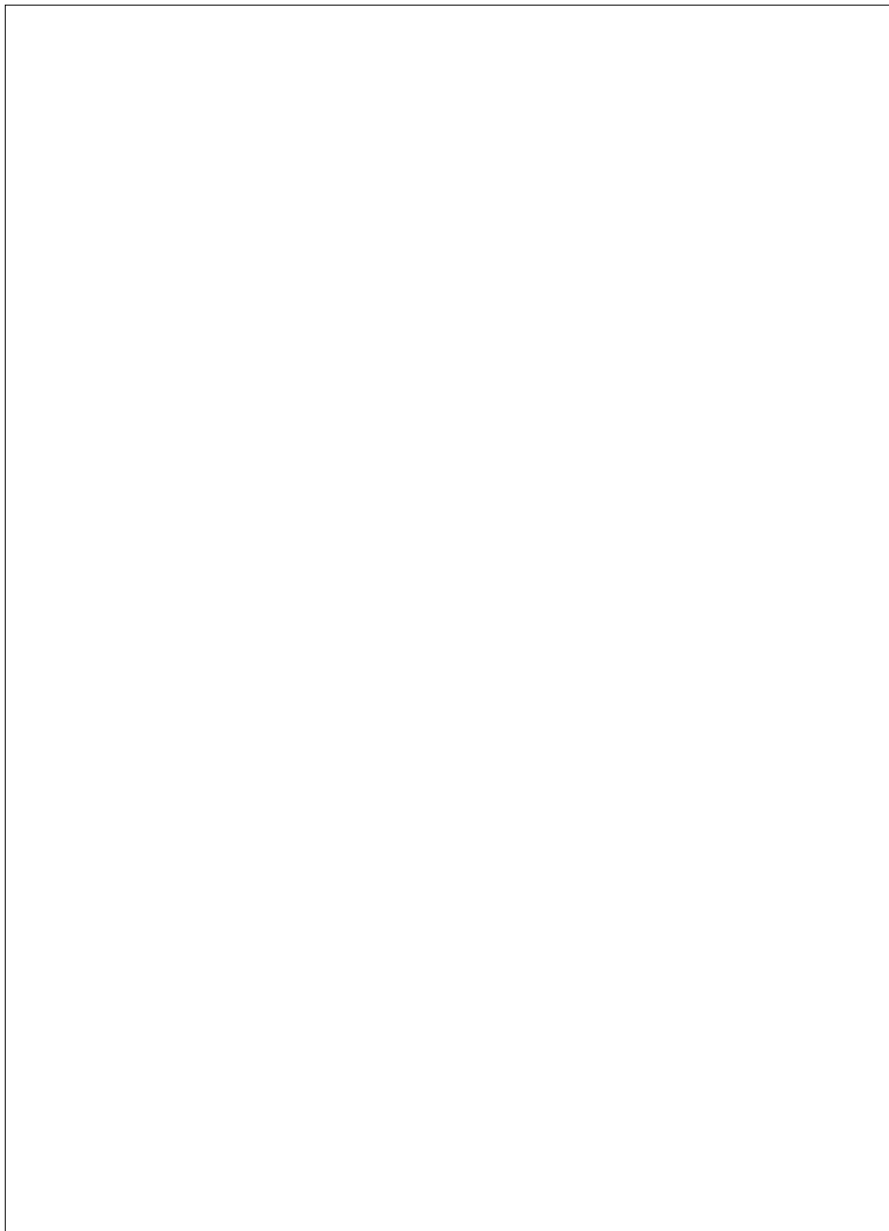

Be sure to save the receipt and attach it to your WARRANTY card when having your equipment repaired at an authorized Sony service center.

For online product registration, please contact
www.sony.com/productregistration

Free Manuals Download Website

<http://myh66.com>

<http://usermanuals.us>

<http://www.somanuals.com>

<http://www.4manuals.cc>

<http://www.manual-lib.com>

<http://www.404manual.com>

<http://www.luxmanual.com>

<http://aubethermostatmanual.com>

Golf course search by state

<http://golfingnear.com>

Email search by domain

<http://emailbydomain.com>

Auto manuals search

<http://auto.somanuals.com>

TV manuals search

<http://tv.somanuals.com>