

Camera Control Unit

Operating Instructions

Before operating the unit, please read this manual thoroughly and retain it for future reference.

**CCU-D50
CCU-D50P**

Owner's Record

The model and serial numbers are located at the rear. Record these numbers in the spaces provided below. Refer to them whenever you call upon your Sony dealer regarding this product.

Model No. _____ Serial No. _____

Important Safety Instructions

- Read these instructions.
- Keep these instructions.
- Heed all warnings.
- Follow all instructions.
- Do not use this apparatus near water.
- Clean only with dry cloth.
- Do not block any ventilation openings. Install in accordance with the manufacturer's instructions.
- Do not install near any heat sources such as radiators, heat registers, stoves, or other apparatus (including amplifiers) that produce heat.
- Do not defeat the safety purpose of the polarized or grounding-type plug. A polarized plug has two blades with one wider than the other. A grounding-type plug has two blades and a third grounding prong. The wide blade or the third prong are provided for your safety. If the provided plug does not fit into your outlet, consult an electrician for replacement of the obsolete outlet.
- Protect the power cord from being walked on or pinched particularly at plugs, convenience receptacles, and the point where they exit from the apparatus.
- Only use attachments/accessories specified by the manufacturer.
- Use only with the cart, stand, tripod, bracket, or table specified by the manufacturer, or sold with the apparatus. When a cart is used, use caution when moving the cart/ apparatus combination to avoid injury from tip-over.
- Unplug this apparatus during lightning storms or when unused for long periods of time.
- Refer all servicing to qualified service personnel. Servicing is required when the apparatus has been damaged in any way, such as power-supply cord or plug is damaged, liquid has been spilled or objects have fallen into the apparatus, the apparatus has been exposed to rain or moisture, does not operate normally, or has been dropped.



WARNING

To prevent fire or shock hazard, do not expose the unit to rain or moisture.

To avoid electrical shock, do not open the cabinet. Refer servicing to qualified personnel only.

THIS APPARATUS MUST BE EARTHED.

CAUTION

The apparatus shall not be exposed to dripping or splashing and no objects filled with liquid, such as vases, shall be placed on the apparatus.

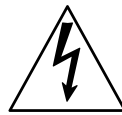
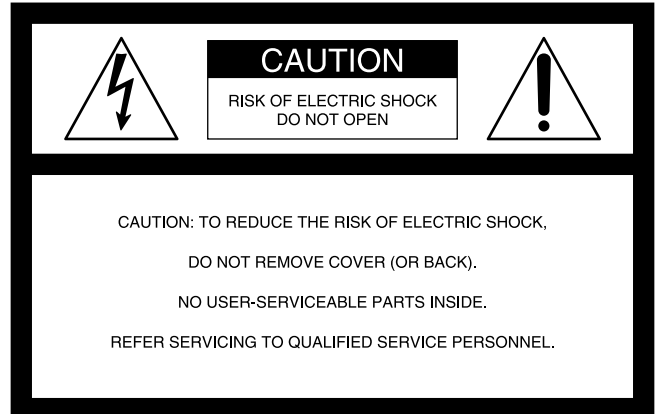

This symbol is intended to alert the user to the presence of uninsulated "dangerous voltage" within the product's enclosure that may be of sufficient magnitude to constitute a risk of electric shock to persons.



This symbol is intended to alert the user to the presence of important operating and maintenance (servicing) instructions in the literature accompanying the appliance.

For customers in the USA (CCU-D50 only)

This equipment has been tested and found to comply with the limits for a Class A digital device, pursuant to Part 15 of the FCC Rules. These limits are designed to provide reasonable protection against harmful interference when the equipment is operated in a commercial environment. This equipment generates, uses, and can radiate radio frequency energy and, if not installed and used in accordance with the instruction manual, may cause harmful interference to radio communications. Operation of this equipment in a residential area is likely to cause harmful interference in which case the user will be required to correct the interference at his own expense.

You are cautioned that any changes or modifications not expressly approved in this manual could void your authority to operate this equipment.

The shielded interface cable recommended in this manual must be used with this equipment in order to comply with the limits for a digital device pursuant to Subpart B of Part 15 of FCC Rules.

For the customers in Europe (CCU-D50P only)

This product with the CE marking complies with both the EMC Directive (89/336/EEC) and the Low Voltage Directive (73/23/EEC) issued by the Commission of the European Community.

Compliance with these directives implies conformity to the following European standards:

EN60065: Product Safety

EN55103-1: Electromagnetic Interference (Emission)

EN55103-2: Electromagnetic Susceptibility (Immunity)

This product is intended for use in the following Electromagnetic Environment(s):

E1 (residential), E2 (commercial and light industrial), E3 (urban outdoors) and E4 (controlled EMC environment, ex. TV studio).

Voor de Klanten in Nederland

- Dit apparaat bevat een vast ingebouwde batterij die niet vervangen hoeft te worden tijdens de levensduur van het apparaat.
- Raadpleeg uw leverancier indien de batterij toch vervangen moet worden.
- De batterij mag alleen vervangen worden door vakbekwaam servicepersoneel.
- Gooi de batterij niet weg maar lever deze in als klein chemisch afval (KCA).
- Lever het apparaat aan het einde van de levensduur in voor recycling, de batterij zal dan op correcte wijze verwerkt worden



Attention-when the product is installed in Rack:

1. Prevention against overloading of branch circuit

When this product is installed in a rack and is supplied power from an outlet on the rack, please make sure that the rack does not overload the supply circuit.

2. Providing protective earth

When this product is installed in a rack and is supplied power from an outlet on the rack, please confirm that the outlet is provided with a suitable protective earth connection.

3. Internal air ambient temperature of this rack

When this product is installed in a rack, please make sure that the internal air ambient temperature of the rack is within the specified limit of this product.

4. Prevention against achieving hazardous condition due to uneven mechanical loading

When this product is installed in a rack, please make sure that the rack does not achieve hazardous condition due to uneven mechanical loading.

5. Install the equipment while taking the operating temperature of the equipment into consideration

For the operating temperature of the equipment, refer to the specifications of the Operating Instructions.

6. When performing the installation, keep the rear of the unit 10 cm (4 inches) or more away from walls in order to obtain proper exhaust and radiation of heat.

Table of Contents

Overview	5
Features	5
Using the CD-ROM Manual	6
Available Functions Depending on the Device	
Connected to the Unit	7
Camera Cable Length.....	8
Rack Mounting	8
Connections	9
Connections for transmitting digital video (SDI) signals	
between this unit and a camera	11
When Using the RM-M7G Remote Control Unit	14
Location and Functions of Parts	15
Front Panel	15
Rear Panel	21
Displaying and Changing Settings	24
Displaying Settings	24
Changing Settings	26
Notes on Use	28
Specifications	29

Features

The CCU-D50/D50P is a camera control unit that can be connected via camera adaptors such as the CA-D50 to DXC-D35/D35WS series digital video cameras (hereafter called cameras) or to DSR-370/570WS series or other DV camcorders (hereafter called camcorders).

This unit has the following features.

Note

When a DXC-D35/D35P/D35WS/D35WSP camera with a serial number indicated in the following table is connected to this unit via a CA-D50, the ROM of the camera must be replaced.

For more information about checking the version and exchanging ROMs, contact your Sony dealer or a Sony service representative.

Camera	Serial number
DXC-D35	10001 to 11325, 18001 to 18581, 100001 to 100356, 110001 to 110030
DXC-D35P	40001 to 42755, 48001 to 49261, 400001 to 402001, 410001 to 410033
DXC-D35WS	10001 to 10750, 18001 to 18336, 100001 to 100394
DXC-D35WSP	40001 to 40420, 48001 to 48366, 400001 to 400030

Digital and analog signal transmission

- Connecting a CA-D50 camera adaptor allows video signals to be transmitted digitally for low signal degradation. (Audio signal transmission is not digital.)
- Connecting a CA-D50 camera adaptor with CCZ cable allows digital video signals to be transmitted up to 75 m (about 246 feet), and analog video signals up to 300 m (about 999 feet).
- The unit has functions to support transmission of return video, prompter signals, and microphone audio.
- The unit has functions for red and green tally and an intercom system.

Remote control of versatile adjustment functions

- Automatic and manual adjustments of white balance, black balance, iris opening and other functions can be made under remote control, together with gain switching and black level adjustments.
- Connecting a remote control panel such as the RCP-TX7 (not available in EU countries) allows cameras/camcorders to be controlled remotely.

Rich variety of input and output signals

The output of the unit is switchable between composite video (VBS), component video (or RGB), S-video, and SDI signals. The unit is equipped with SDI signal input and output connectors and an external reference video signal input connector.

Rack mountable

The unit can be mounted in an EIA standard 19-inch rack.

Using the CD-ROM Manual

The supplied CD-ROM includes operation manuals for the CCU-D50 series of camera control unit (English, French, German, Italian and Spanish versions).

CD-ROM System Requirements

The following are required to access the supplied CD-ROM disc.

- Computer: PC with MMX Pentium 166 MHz or faster CPU, or Macintosh computer with PowerPC CPU.
 - Installed memory: 32 MB or more
 - CD-ROM drive: × 8 or faster
- Monitor: Monitor supporting resolution of 800 × 600 or higher

When these requirements are not met, access to the CD-ROM disc may be slow, or not possible at all.

Preparations

The following software must be installed on your computer in order to use the operation manuals contained in the CD-ROM disc.

- Microsoft Internet Explorer Version 4.0 or higher, or Netscape Navigator Version 4.0 or higher
- Adobe Acrobat Reader Version 4.0 or higher

Notes

- If Microsoft Internet Explorer is not installed, it may be downloaded from the following URL:
<http://www.microsoft.com/ie>
- If Netscape Navigator is not installed, it may be downloaded from the following URL:
<http://home.netscape.com/>
- If Adobe Acrobat Reader is not installed, it may be downloaded from the following URL:
<http://www.adobe.com/products/acrobat/readstep.html>

To Read the CD-ROM Manual

To read the operation manual contained in the CD-ROM disc, do the following.

- 1** Insert the CD-ROM disc in your CD-ROM drive.

A cover page appears automatically in your browser.

If it does not appear automatically in the browser, double click the index.htm file on the CD-ROM disc.

- 2** Select and click the operation manual that you want to read.

A PDF file of the operation manual opens.

Note

If you lose the CD-ROM disc or become unable to read its content, for example because of a hardware failure, contact a Sony service representative.

-
- MMX and Pentium are registered trademarks of Intel Corporation or its subsidiaries in the United States and other countries.
 - PowerPC is a registered trademark of International Business Machines Corporation.
 - Macintosh is a registered trademark of Apple Computer, Inc.
 - Microsoft is a registered trademark of Microsoft Corporation in the United States and/or other countries.
 - Netscape Navigator is a registered trademark of Netscape Communications Corporation in the U.S. and other countries.
 - Adobe and Acrobat are registered trademarks of Adobe Systems Incorporated in the United States and/or other countries.

Available Functions Depending on the Device Connected to the Unit

The following explains the types of signals which can be output and the functions which are available depending on the device connected to this unit.

Output signals

Device connected to the unit	Output signals ^{a)}				
	SDI	VBS	RGB	S-video	Y/R-Y/B-Y
DXC-D35/D35P/D35WS/D35WSP camera + CA-D50 camera adaptor	Yes	Yes	Yes	Yes	Yes
DXC-D35/D35P/D35WS/D35WSP camera + CA-537/537P camera adaptor	No	Yes	Yes	Yes	Yes
DSR-370/370P/570WS/570WSP camcorder	No	Yes	No	No	Yes

a) SDI, RGB, S-video and Y/R-Y/B-Y cannot be output simultaneously.

Adjustment items

Device connected to the unit	Command mode ^{a)}	Detail	Shutter	Clear scan	Knee	Auto knee	ATW	Master gamma
DXC-D35/D35P/D35WS/D35WSP camera + CA-D50 camera adaptor	TX7 mode	Yes	Yes	Yes	Yes	Yes	Yes	Yes
DXC-D35/D35P/D35WS/D35WSP camera + CA-D50 camera adaptor	M5A mode	Yes	Yes	Yes	Yes	Yes	Yes	No
DXC-D35/D35P/D35WS/D35WSP camera + CA-537/537P camera adaptor	M5A mode	Yes	Yes	Yes	Yes	Yes	Yes	No
DSR-370/370P/570WS/570WSP camcorder	M5A mode	Yes	Yes	Yes	Yes	Yes	Yes	No

a) About command mode, see “**16** System setting switches” on page 18.

Remote controller, remote control panel, green tally support

Device connected to the unit	Command mode ^{a)}	RM-M7G	RCP-TX7	Green tally
DXC-D35/D35P/D35WS/D35WSP camera + CA-D50 camera adaptor	TX7 mode	Yes	Yes	Yes
DXC-D35/D35P/D35WS/D35WSP camera + CA-D50 camera adaptor	M5A mode	Yes	No	No
DXC-D35/D35P/D35WS/D35WSP camera + CA-537/537P camera adaptor	M5A mode	Yes	No	No
DSR-370/370P/570WS/570WSP camcorder	M5A mode	Yes	No	No

a) About command mode, see “**16** System setting switches” on page 18.

Overview

Return video signals

When this unit is connected to a camera via a CA-D50 or CA-537/537P Camera Adaptor or when it is connected to a DSR-370/370P/570WS/570WSP camcorder, return video signals can be sent to the camera/camcorder.

Note

When using a CA-537/537P with a serial number of 33271 or higher, set the return signal mode to B&W (see “16 System setting switches” on page 18).

Prompter signals

Prompter signals can be sent to a camera adaptor when this unit is connected to a CA-D50 or a CA-537/537P with a serial number of 33271 or higher. When sending prompter signals, set the return signal mode to B&W (see “16 System setting switches” on page 18).

When a DSR-370//370P/570WS/570WSP camcorder is connected to this unit, it is not possible to send prompter signals to the camcorder.

Camera Cable Length

When using an optional CCZ-An camera cable (n in the model name is a number expressing the cable length in meters), analog transmission distance can be extended up to a maximum of 300 meters (about 999 feet), and digital transmission distance can be extended up to about 75 m (about 246 feet). Use the CABLE COMP buttons (see page 17) on this unit to set a cable compensation value according to the length of the cable you are using.

When a DSR-370//370P/570WS/570WSP camcorder is connected to this unit, reference sync signal and return signal transmission distance can be extended up to 150 m (about 492 feet).

Rack Mounting

The unit can be mounted in a standard 19-inch studio rack with the supplied mounting brackets.

For more information about rack mounting, contact your Sony dealer or a Sony service representative.

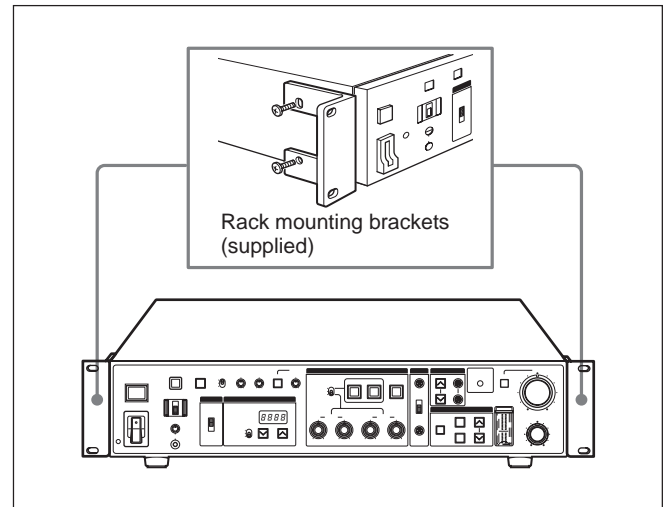

Connections

The following provides examples of how to connect other devices to this unit.

Notes

- Be sure to power this unit off before connecting or disconnecting camera cables.

- Some of the camera/camcorder's switches and knobs may not operate while this unit is connected to it.

For details, refer to the operation manual of the camera/camcorder or camera adaptor.

When using one CCU-D50/D50P unit

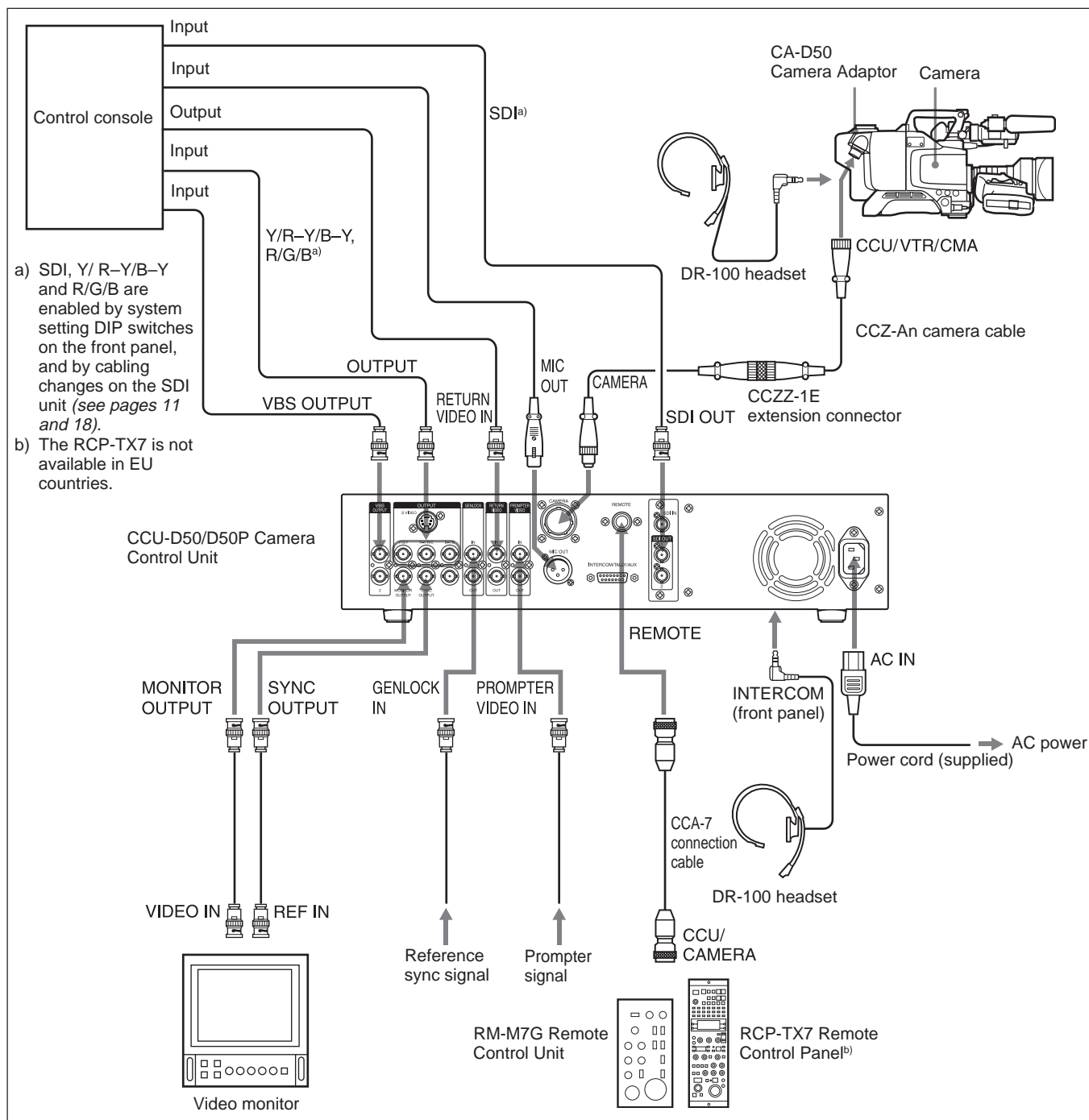

Overview

When using two CCU-D50/D50P units

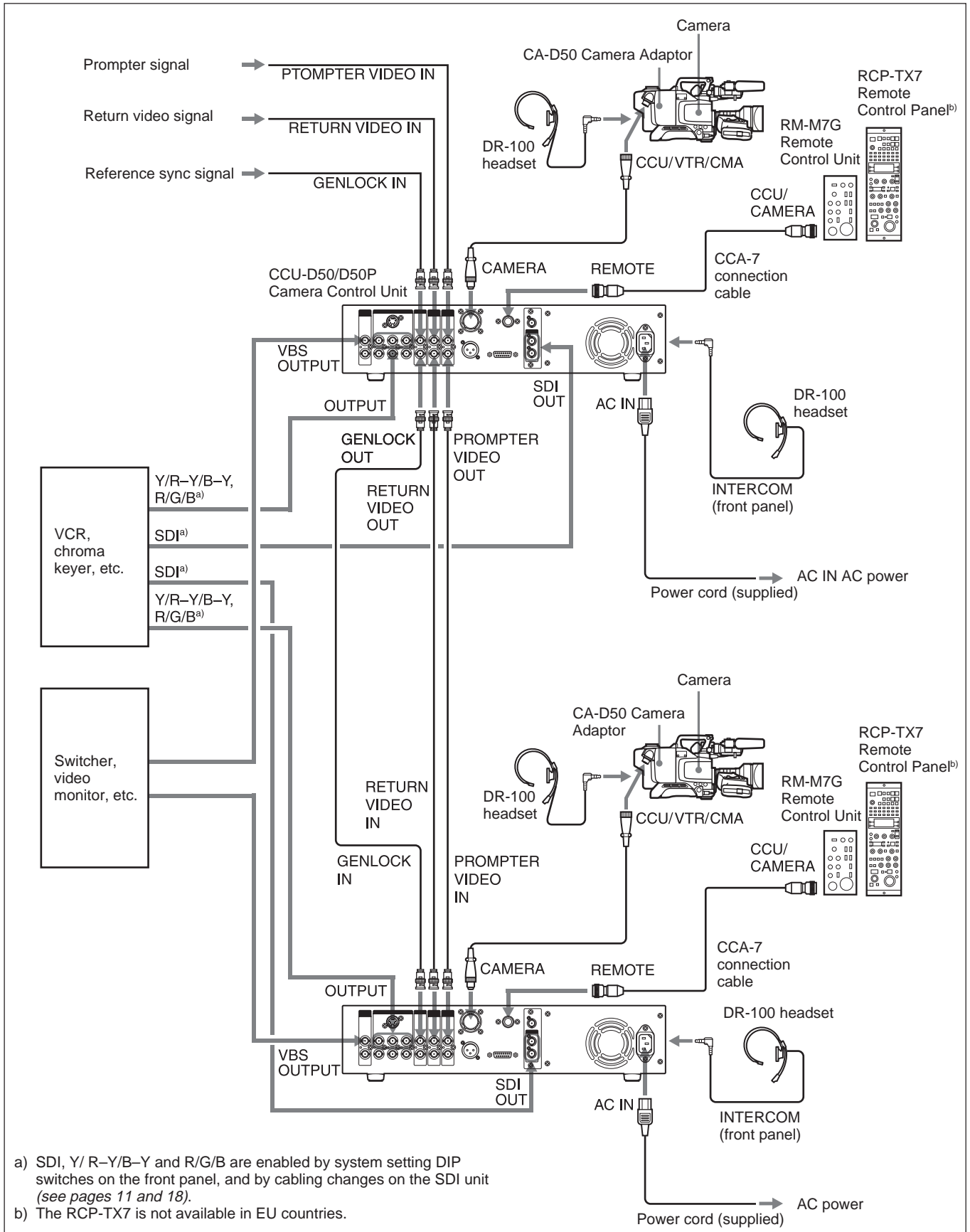

Connections for transmitting digital video (SDI) signals between this unit and a camera

In a system consisting of this unit, a DXC-D35/D35P/D35WS/D35WSP camera, and CA-D50 Camera Adaptor, digital video (SDI) signals can be transmitted between this unit and the camera.

The maximum transmission distance over CCZ camera cable is 75 m (246 feet). The maximum transmission distance over coaxial cable is 200 m (656 feet). To transmit over CCZ cable, you will need to change the cabling in the SDI unit of this unit to SDI mode, and to turn digital transmission on with the system setting switches.

Connections for transmission over CCZ cable (max. length 75 m (246 feet))

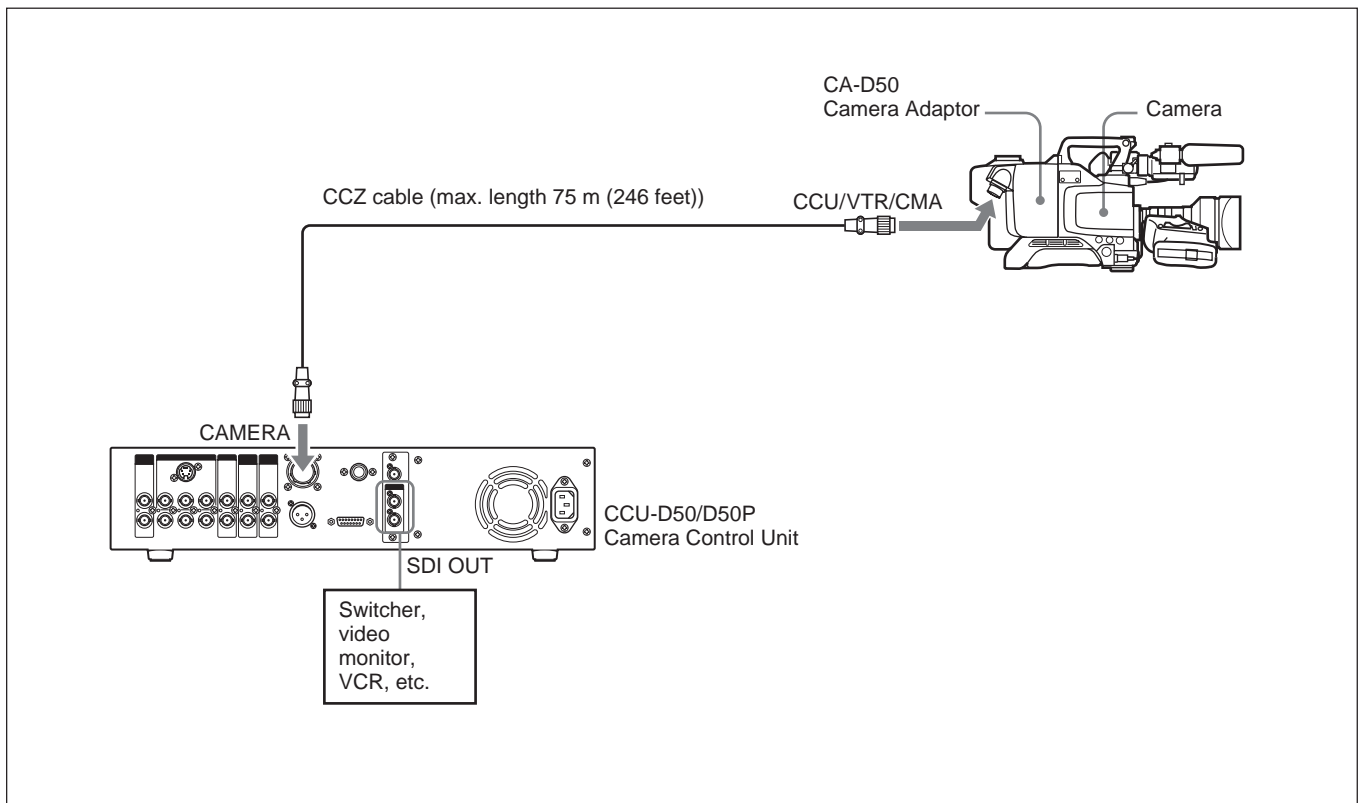

Use the procedure described on the next page to change the cabling in the SDI unit of this unit to SDI mode, and turn digital transmission on with the system setting switches.

Notes

- Set the system setting switches as soon as you change the cabling.
- Y/R–Y/B–Y signals, RGB signals, and S-video signals are not output when transmitting over CCZ cable.

Overview

Note

Be sure to power this unit off before proceeding to the following operation.

- 1 Remove the two screws and gently pull the SDI unit out.

Note

Be careful not to pull the SDI unit out too far. Doing so may disconnect or damage the connectors.

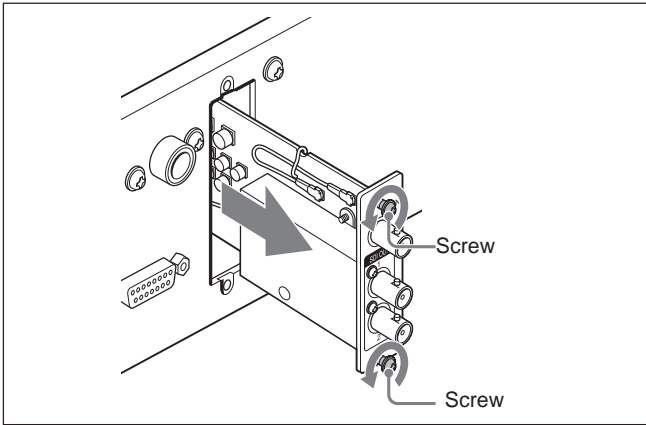

- 2 Open the cable holders of the SDI unit.

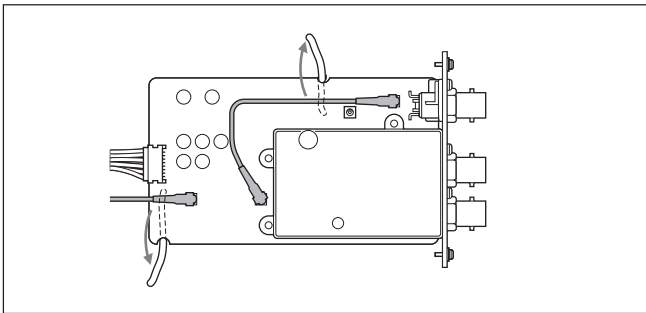

- 3 Change the connections for both cables as shown below.

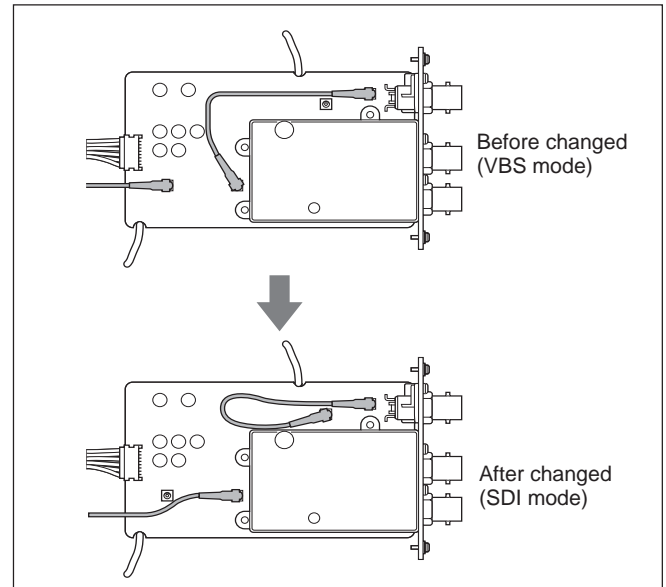

- 4 Close the cable holders.
- 5 Repeat step 1 in reverse to return the SDI unit to its original position.
- 6 Open the cover of the setting switches on the front panel.
- 7 Set system setting switch 3 as shown below.

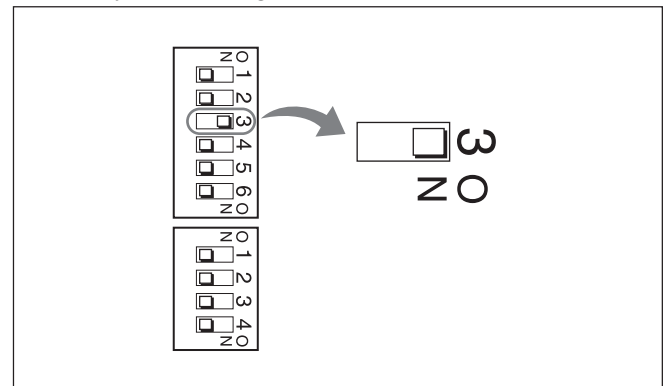

Connections for transmission over RG cable (6/U or 6A/U) (max. length 200 m (656 feet))

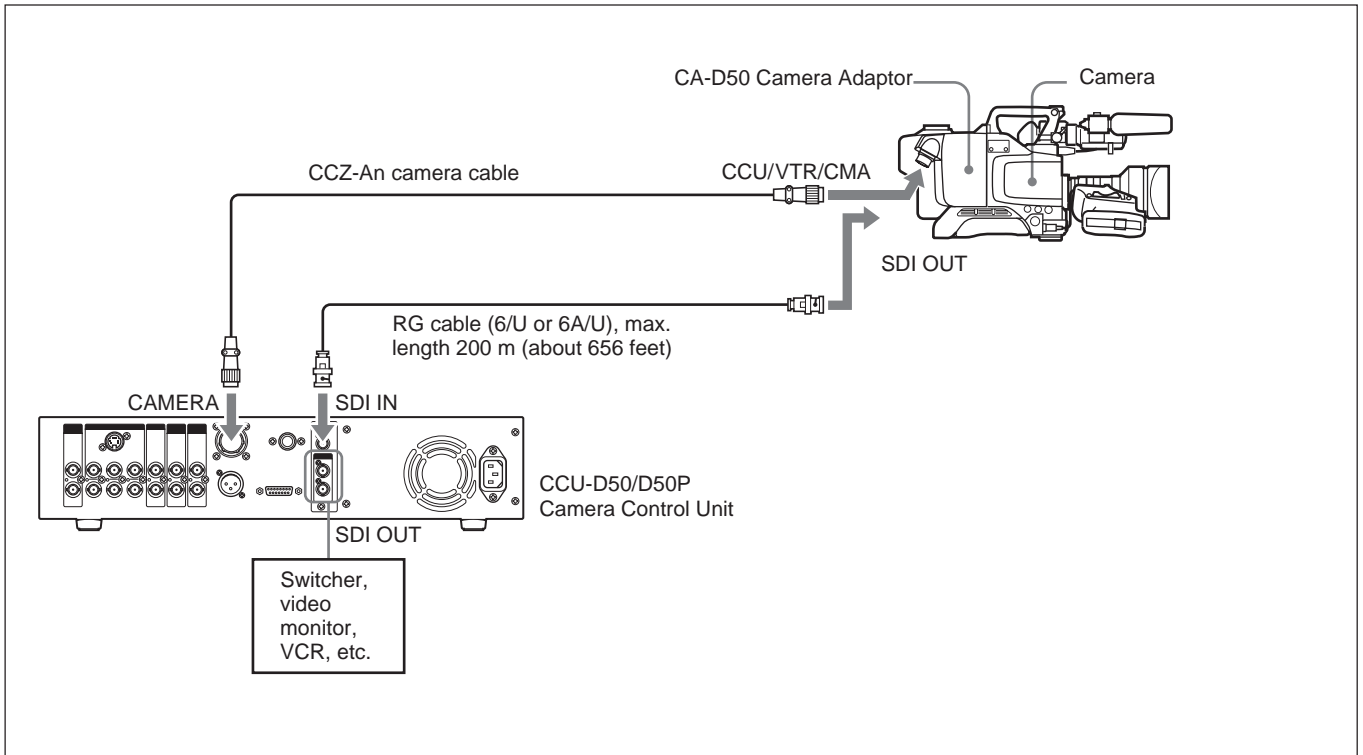

Check that the cabling in the SDI unit of this unit is set to VBS mode, and that digital transmission is turned off with the system setting switches. (See step 3 and 7 in "Connections for transmission over CCZ cable" on page 11.)

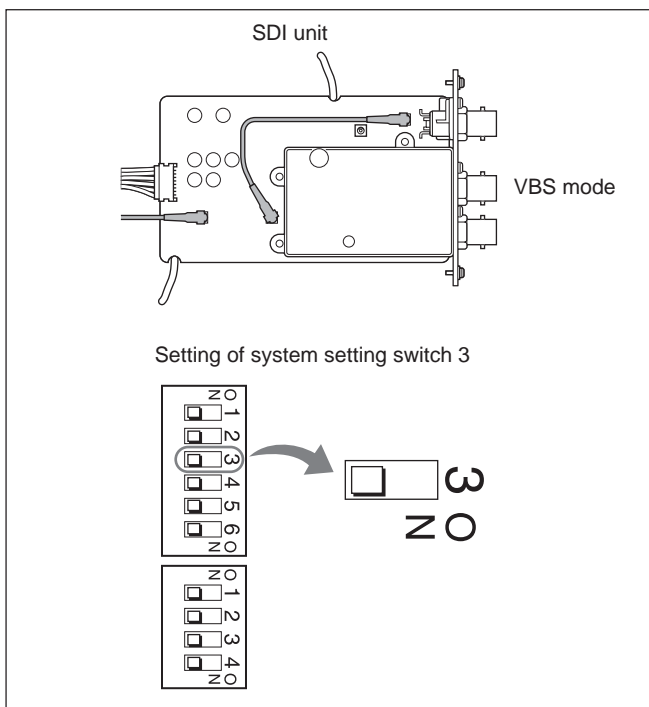

When Using the RM-M7G Remote Control Unit

The RM-M7G Remote Control Unit can be connected directly to this unit. When this unit is powered on, it is set up to control the camera/camcorder. If you have connected an RM-M7G, do the following to set up this unit and the RM-M7G for control from the RM-M7G.

- 1** Set the system setting switches (see “**16** System setting switches” on page 18) on the front panel of this unit according to the connected device.
- 2** Do the following on the RM-M7G.
 - Set the CAMERA SELECT switch to 1.
 - Press the PANEL ACTIVE button.

To control the video camera from this unit

Press the PANEL ACTIVE button on the front panel.

Note

When the camera is being controlled from the front panel of this unit or during automatic white/black balance adjustment, the PANEL ACTIVE button on the RM-M7G may not work. If this occurs, press the RM-M7G PANEL ACTIVE button after completion of the camera control operation from the front panel of this unit or automatic white/black balance adjustment operation.

Location and Functions of Parts

Front Panel

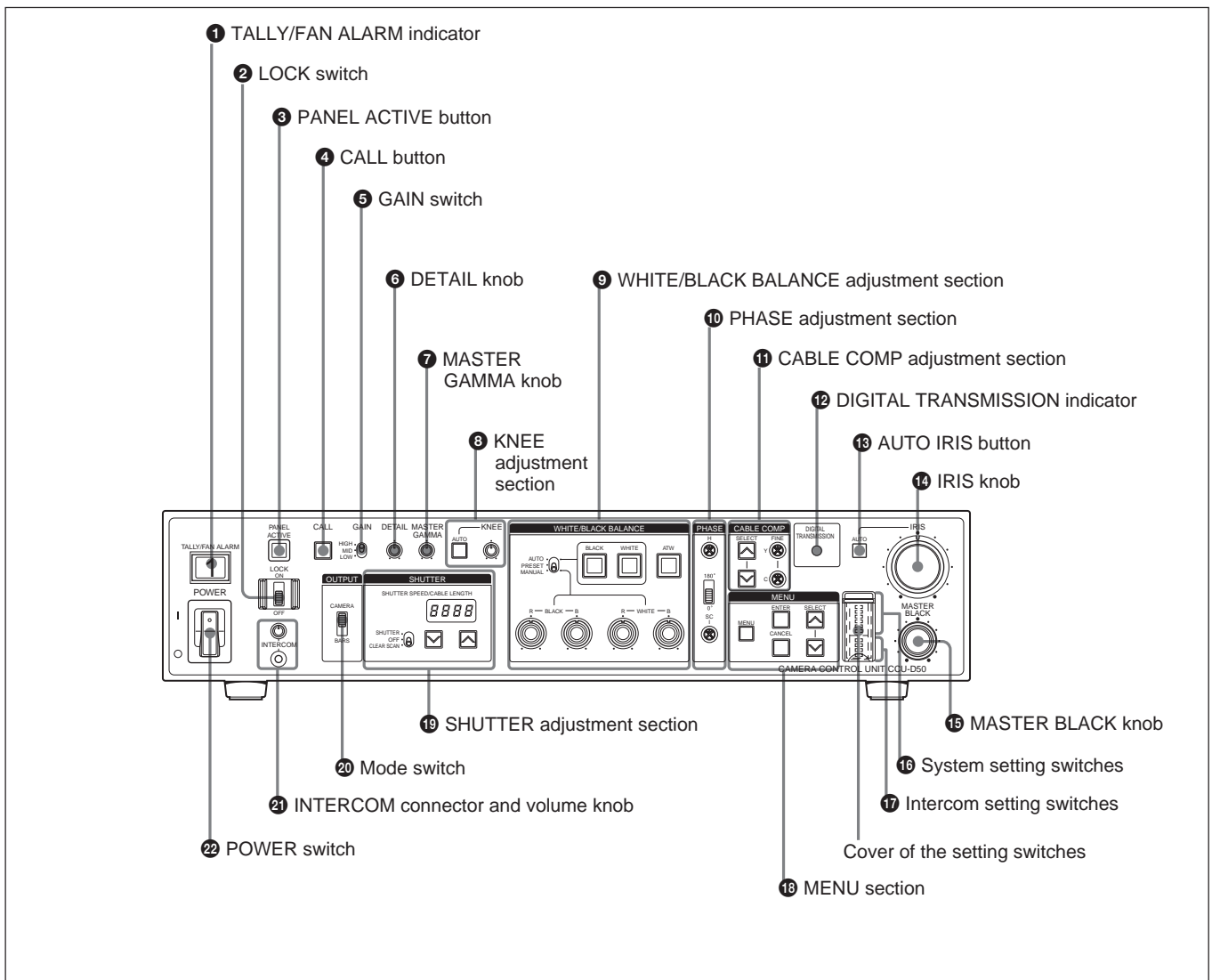

1 TALLY/FAN ALARM indicator

Lights in red when a red tally signal is received, and lights in green when a green tally signal is received. Also lights when the CALL button of the camera/camcorder or this unit is pressed.

This unit is equipped with a cooling fan. If the fan should fail, this indicator flashes in red. Power the unit off immediately and contact your Sony dealer or a Sony service representative for repair. Continuing to use the unit with a malfunctioning fan may shorten the life of this unit.

You can attach the supplied camera number plates to this indicator (*see the following figure*).

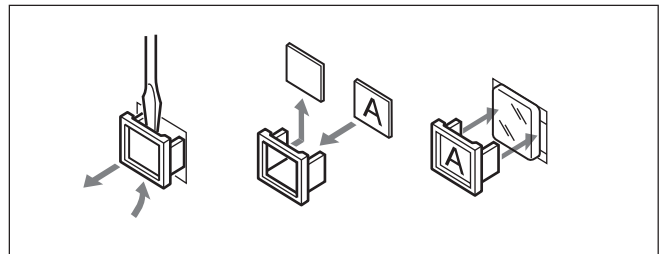

2 LOCK switch

Locks and unlocks the controls on this unit.

ON: Locks all controls on this unit except the CALL button, the INTERCOM volume knob, and the CABLE COMP buttons and CABLE COMP FINE screws.

OFF: Unlocks the controls. Normally leave the switch in this position.

Location and Functions of Parts

3 PANEL ACTIVE button

When the camera/camcorder connected to this unit is being controlled remotely by a remote control unit such as the RM-M7G, pressing this button causes the button to light up and assumes control of the camera/camcorder from this unit. The controls on the front panel are enabled while this button is lit. Pressing the PANEL ACTIVE button on another device causes this button to go off and transfers control of the camera/camcorder away from this unit. This button flashes while the camera/camcorder is powered off.

4 CALL button

Press to call the camera/camcorder operator over the intercom. Pressing this button lights the tally indicators in the camera's viewfinder and on this unit.

5 GAIN switch

Selects one of three video amplifier gain levels (HIGH, MID, LOW). The gain values corresponding to HIGH, MID, and LOW are set by using the menu on the camera/camcorder.

6 DETAIL knob

Rotate to adjust the contours of objects in the picture.

7 MASTER GAMMA knob

Adjusts the gamma curve. The central click position of the KNEE/M.GAMMA/DETAIL knob corresponds to the camera/camcorder preset value.

8 KNEE adjustment section

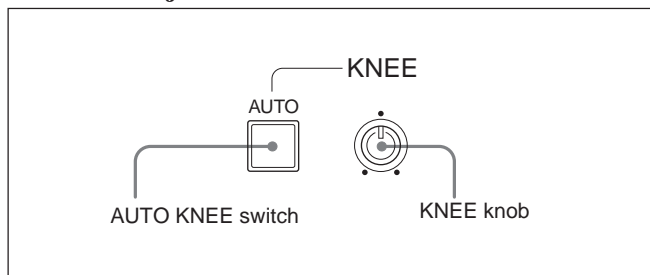

AUTO KNEE switch

Pressing this switch, lighting it, to activate the auto knee circuits and adjust knee automatically.

KNEE knob

Adjusts the knee point when the auto knee circuits are off (when the AUTO KNEE switch is not lit).

9 WHITE/BLACK BALANCE adjustment section

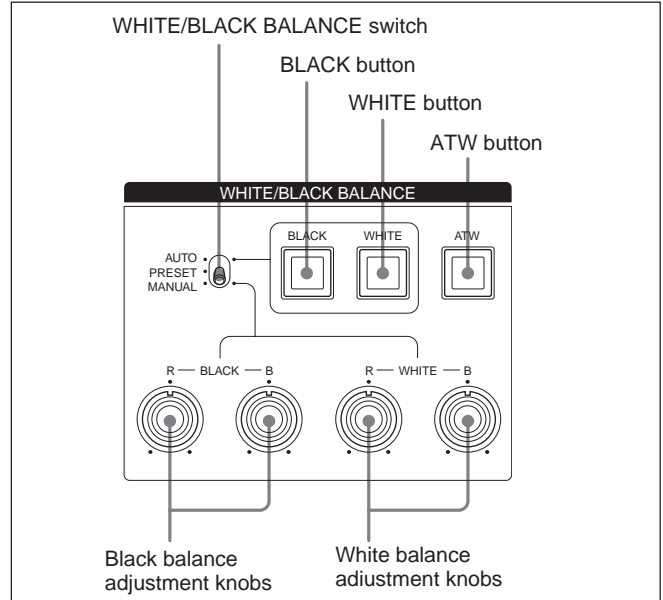

WHITE/BLACK BALANCE switch

Selects the white and black balance adjustment mode.

AUTO: Selects auto adjustment mode, which allows you to adjust the white or black balance by pressing the WHITE or BLACK button. Adjusted values are saved in camera/camcorder memory and called up again when the switch is set to this position again.

PRESET: The white balance value is returned to the preset value. Black balance can be adjusted automatically by pressing the BLACK button.

MANUAL: Selects manual mode, which allows you to adjust the black and white balance with the black balance and white balance adjustment knobs.

BLACK (black balance automatic adjustment) button

Adjusts the black balance automatically when the WHITE/BLACK BALANCE switch is set to AUTO or PRESET. This button lights when adjustment starts, and goes off if adjustment is completed successfully. If adjustment could not be completed successfully, this button flashes for eight seconds at an intervals of about 0.5 seconds.

WHITE (white balance automatic adjustment) button

Adjusts the white balance automatically when the WHITE/BLACK BALANCE switch is set to AUTO or PRESET. This button lights when adjustment starts, and goes off if adjustment is completed successfully. If adjustment could not be completed successfully, this button flashes for eight seconds at an intervals of about 0.5 seconds.

ATW (auto tracking white balance) button

Press this button, lighting it, to adjust white balance automatically according to changes in lighting conditions.

Black balance adjustment knobs

Adjust the black level.

When the WHITE/BLACK BALANCE switch is set to MANUAL, the R knob adjust red components and the B knob adjusts blue components.

White balance adjustment knobs

Adjust the white level.

When the WHITE/BLACK BALANCE switch is set to MANUAL, the R knob adjust red components and the B knob adjusts blue components.

10 PHASE adjustment section

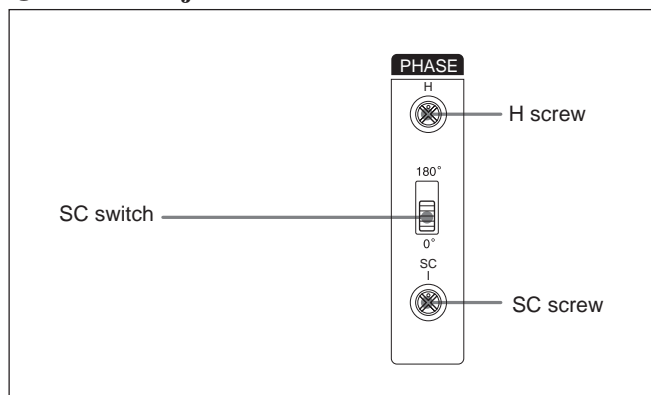

H (horizontal phase adjustment) screw

Use a screwdriver or other tool to adjust the horizontal phase difference between the output signal and an external sync signal.

SC (subcarrier phase adjustment) switch

Adjust the subcarrier phase difference between the output signal and an external sync signal.

SC (subcarrier phase adjustment) screw

After adjusting the subcarrier phase with the SC switch, use a screwdriver or other tool to make fine adjustments by rotating this screw.

11 CABLE COMP (cable compensation) adjustment section

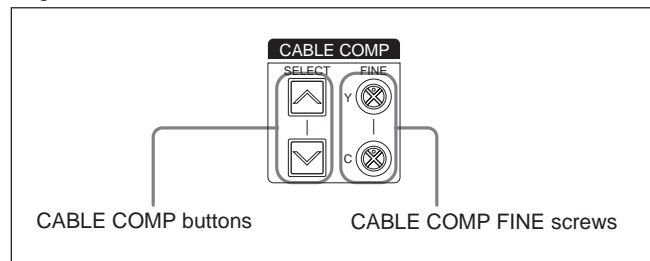

CABLE COMP (cable compensation) buttons

Use these button to adjust cable compensation for the length of the cable you are using. The internal cable compensation circuits prevent signal degradation by adjusting for the length of the cable. Settings are displayed in the SHUTTER SPEED/CABLE LENGTH display window (see page 20).

To change a setting, press the upper or lower button and keep it pressed for about one second. Then release the button and press it again within two seconds. Press and release the button quickly to display the current setting for two seconds.

Set to "L 25" for a cable 10 m (about 33 feet) or less in length.

CABLE COMP FINE (cable compensation fine adjustment) screws

Makes fine compensation adjustments to the video signal output from the VBS OUT connector. After using the CABLE COMP buttons to adjust for cable length, make fine adjustments by rotating these screws with a screwdriver or other tool. The Y screw adjusts the Y (luminance) signal, and the C screw adjusts the C (chroma) signals.

12 DIGITAL TRANSMISSION indicator

Lit in green: Digital signals are being transmitted from the camera/camcorder by CCZ cable or by BNC cable connected to the SDI IN connector.

Lit in red: The unit is in digital transmission mode, but there are no digital video signals being transmitted from the camera/camcorder.

Flashing in red: The unit is in digital transmission mode, but there are no digital or analog video signals being transmitted from the camera/camcorder because the cables are not connected or because the camera/camcorder is powered off.

Location and Functions of Parts

Not lit: The unit is not in digital transmission mode (factory default setting).

13 AUTO IRIS button

Selects the iris adjustment mode. Before using this button, set the IRIS switch on the camera/camcorder to AUTO.

OFF (not lit): Manual adjustments can be made with the IRIS knob.

ON (lit): The iris is adjusted automatically.

14 IRIS knob

When the AUTO IRIS button is off, adjust the camera/camcorder lens iris by rotating this knob. When the button is on, the iris is adjusted automatically.

15 MASTER BLACK knob

Adjusts the video signal black level.

16 System setting switches

Set the following items. Power this unit off before setting switches.

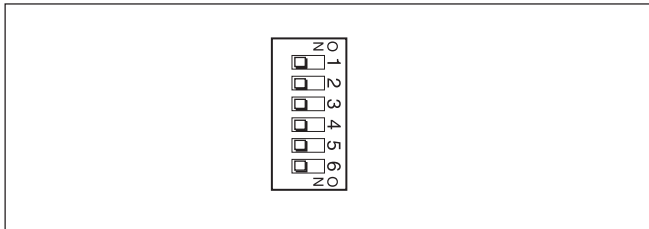

Switch	Item	OFF (default)	ON
Switch 1	CCU command mode	M5A mode	TX7 mode
Switch 2	Return signal mode	Color	B/W
Switch 3	Digital transmission	OFF	ON
Switch 4	Output mode 1	Y/R-Y/B-Y	R/G/B
Switch 5	Output mode 2	Y/R-Y/B-Y	Y/C
Switch 6	Remote/local	Remote	Local

Switch 1: CCU command mode

OFF: Use CCU-M5A system commands (M5A mode). This unit can be used to carry out similar control operations to those available with the CCU-M5A/M5AP.

ON: Use CCU-TX7 system commands (TX7 mode). Select ON (TX7 mode) when this unit is used with CA-D50. The RCP-TX7 (not available in EU countries) can be used in TX7 mode.

Set to off (M5A mode) when this unit is connected to a DSR-370/370P/570WS/570WSP or when this unit is connected to a camera via a CA-537/537P.

Switch 2: Return signal mode

OFF: Transmit color as the return signal.

ON: Transmit B/W as the return signal.

Prompter signals cannot be transmitted when color is selected. Select B/W when using prompter signals.

Switch 3: Digital transmission

ON: Selects digital transmission between this unit and the camera adaptor.

OFF: Selects analog transmission between this unit and the camera adaptor.

For digital transmission, cabling must be changed in the SDI unit of this unit.

Switches 4 and 5: Output mode 1 and output mode 2

Select the type of analog signal output from this unit.

Y/R-Y/B-Y: Output Y, R-Y, and B-Y signals from the Y/G/Y, R-Y/R/C, and B-Y/B OUTPUT connectors. Set the switches as follows.

Switch 4	OFF
Switch 5	OFF

Nothing is output from the S VIDEO connector.

R/G/B: Output G, R, and B signals from the Y/G/Y, R-Y/R/C, and B-Y/B OUTPUT connectors. Set the switches as follows.

Switch 4	ON
Switch 5	- (ON/OFF both OK)

Nothing is output from the S VIDEO connector.

Y/C: Output S-video signals from the S VIDEO OUTPUT connector. Set the switches as follows.

Switch 4	OFF
Switch 5	ON

Note

When switch 3 (digital transmission) is on, the settings of switches 4 and 5 are ignored and no signals are output from any of the Y/G/Y, R-Y/R/C, and S VIDEO connectors.

Switch 6: Remote/local

When switch 1 (CCU command mode) is set to on (TX7 mode), selects whether to control the camera/camcorder from a device connected to the REMOTE connector on the rear panel of this unit or from the front panel.

OFF: Operations on the device connected to the REMOTE connector receive priority.

ON: Operations on the front panel of this unit receive priority.

Note

This switch is disabled when an RM-M7G is connected.

17 Intercom setting switches

Set the intercom mode using switches 1 to 3. Switch 4 is not used.

Power this unit off before setting switches.

Setting to 4W mode

Switch 1	INCOM mode 1	OFF	
Switch 2	INCOM mode 2	OFF	
Switch 3	INCOM mode 3	OFF	

Setting to 2W mode

Switch 1	INCOM mode 1	ON	
Switch 2	INCOM mode 2	– (ON/OFF both OK)	
Switch 3	INCOM mode 3	– (ON/OFF both OK)	

Setting to RTS mode

Switch 1	INCOM mode 1	OFF	
Switch 2	INCOM mode 2	ON	
Switch 3	INCOM mode 3	– (ON/OFF both OK)	

Setting to CLEARCOM mode

Switch 1	INCOM mode 1	OFF	
Switch 2	INCOM mode 2	OFF	
Switch 3	INCOM mode 3	ON	

Note

Always set to 4W mode when there is nothing connected to the INTERCOM/TALLY/AUX connector on the rear panel of this unit. The intercom system may not operate correctly if this switch is set to another mode.

For more information about intercom system connections, contact your Sony dealer or a Sony service representative.

18 MENU section

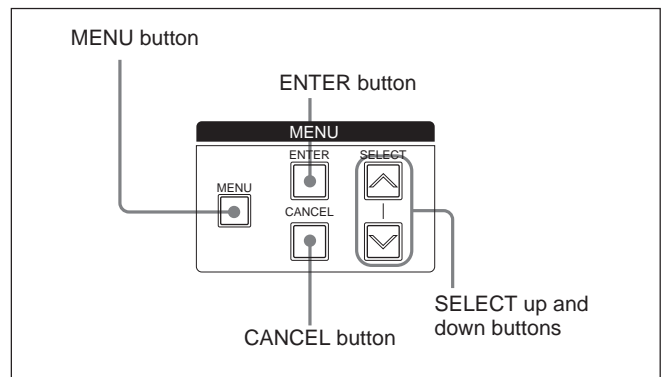

MENU button and indicator

When you press the MENU button, the indicator lights and a menu is displayed on the monitor connected to the MONITOR OUT connector.

On how to change system settings, see page 26.

SELECT up and down buttons

Use to switch between menu pages or settings display pages, to move the arrow within a menu, and to change menu item settings.

ENTER button

Confirms the settings made with the SELECT up and down buttons.

CANCEL button

Cancels the currently selected state and returns the item to its original state.

Location and Functions of Parts

19 SHUTTER adjustment section

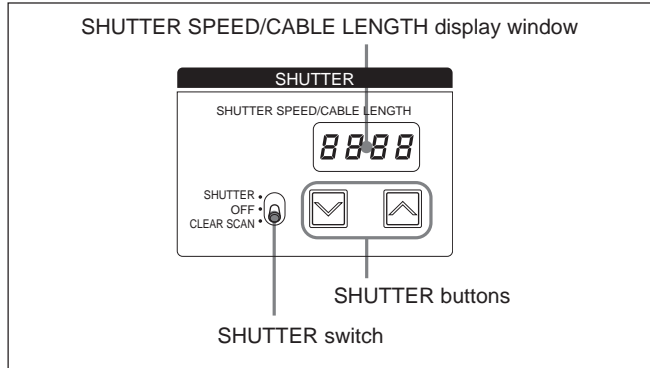

SHUTTER switch

Selects whether or not to use electronic shutter.

SHUTTER: Turns the normal shutter function on.

OFF: Do not use the shutter function.

CLEAR SCAN: Use the clear scan function.

SHUTTER buttons

When the SHUTTER switch is set to CLEAR SCAN or SHUTTER, change the shutter speed or clear scan frequency setting as follows.

When the SHUTTER switch is set to CLEAR

SCAN: Change the clear scan frequency while the button is kept pressed. Press the \wedge button to increase the frequency and the \vee button to decrease it. Pressing both buttons simultaneously resets clear scan frequency to its factory default value.

When the SHUTTER switch is set to SHUTTER:

Change the shutter speed in units of 1 while the button is kept pressed. Press the \wedge button to increase the speed and the \vee button to decrease it.

Note

When EVS is set to ON, "EVS" is displayed. When TLCS is set to ON, "----" is displayed. The shutter speed and clear scan frequency cannot be changed in these cases.

For more information about EVS and TLCS settings, see "Changing Settings" on page 26.

SHUTTER SPEED/CABLE LENGTH display window

When the SHUTTER switch is set to CLEAR SCAN or SHUTTER, displays the shutter speed or clear scan frequency. When the SHUTTER switch is set to OFF, displays "OFF". When the CABLE COMP button (see page 17) is pressed, displays the letter "L" followed by the length of the cable (unit meters).

20 Mode switch

Selects the output signal from this unit.

CAMERA: Camera signal.

BARS: Color bars signal.

21 INTERCOM connector (minijack) and volume knob

Connect a headset such as the DR-100. Adjust the headset speaker volume with the volume knob.

22 POWER switch

Press the "I" side to power this unit on. To power the unit off, press the "O" side of this switch.

Rear Panel

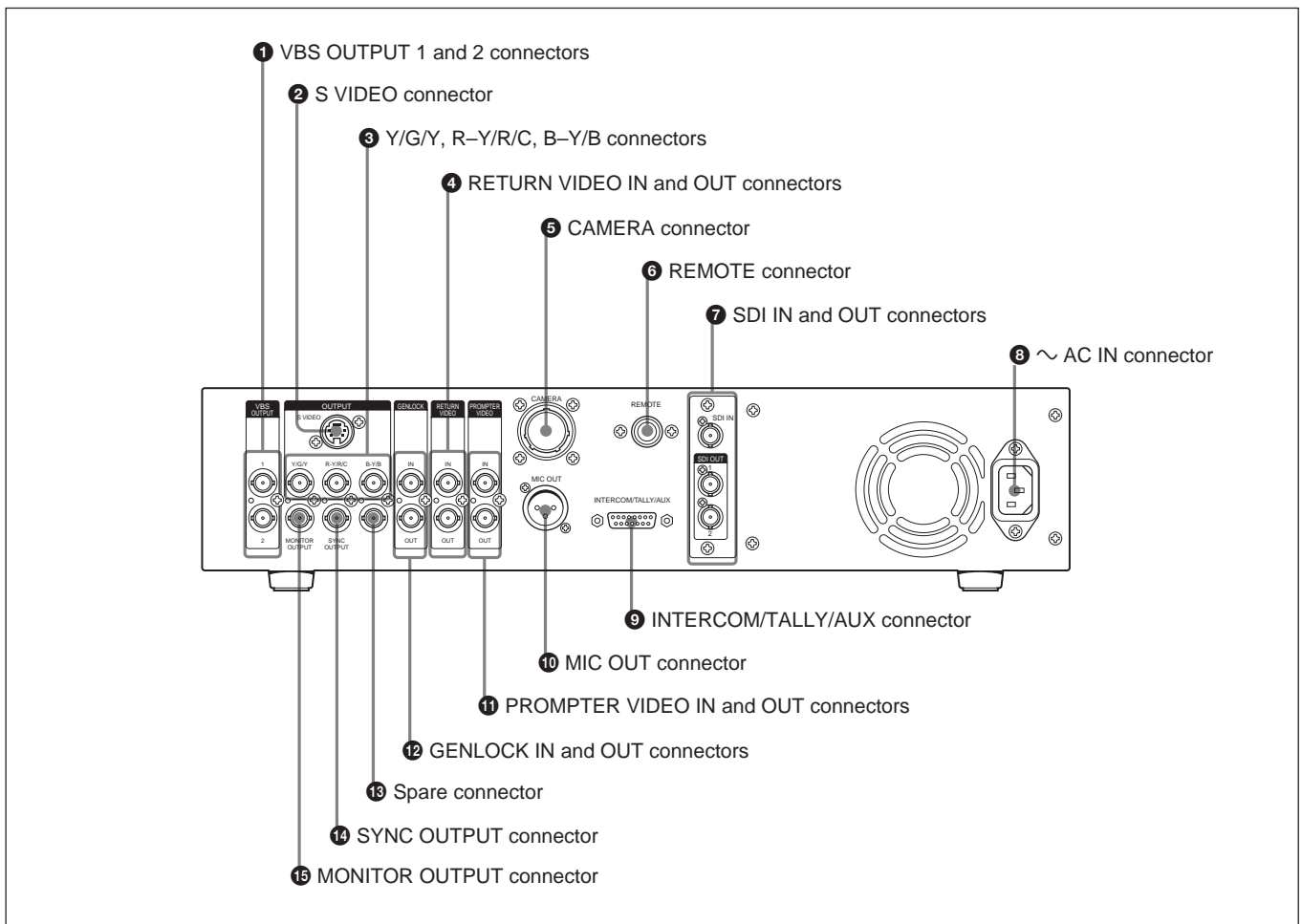

1 VBS OUTPUT (composite video output) 1 and 2 connectors (BNC type)

Output composite video signals. Both connectors output the same signal.

2 S VIDEO (S-video output) connector (Mini-DIN, 4-pin)

Outputs S-video signals.

3 Y/G/Y, R-Y/R/C, B-Y/B (video output) connectors (BNC type)

Output R/G/B signals, Y, R-Y, B-Y component signals, or YC signals.

4 RETURN VIDEO IN and OUT connectors (BNC type)

During on-air transmission or recording, the IN connector accepts signals from devices such as a control console or special effect generator, and the OUT connector supplies the same signal to the camera viewfinder. These connectors have a loop-through configuration, with the signal input to the IN connector being directly output from the OUT connector. The OUT connector is terminated automatically when nothing is connected to it.

Location and Functions of Parts

Note

When using B/W return mode (see “**16** System setting switches” on page 18) and inputting a return video signal to the RETURN VIDEO IN connector, always input a reference sync signal to the GENLOCK IN connector to synchronize the return video signal with the sync signal. Failure to synchronize the return video signal with a sync signal can cause camera/camcorder synchronization to become unstable.

5 CAMERA connector (Z-type, 26-pin)

Connect a CCZ-An camera cable (not supplied) here to connect this unit to devices such as a CA-D50 camera adaptor on the camera.

6 REMOTE connector (10-pin)

Using an CCA-7 connection cable (not supplied), connect to an RM-M7G Remote Control Unit (not supplied) or an RCP-TX7 (not supplied). The RCP-TX7 is not available in EU countries.

7 SDI IN and OUT connectors

These are input and output connectors for digital video (SDI) signals.

8 ~AC IN connector

Connect to an AC power source using the supplied power cord.

9 INTERCOM/TALLY/AUX connector (D-sub, 15-pin)

Inputs and outputs tally and intercom signals. Connect to the tally/intercom connector of the intercom system.

INTERCOM/TALLY/AUX connector pin assignment

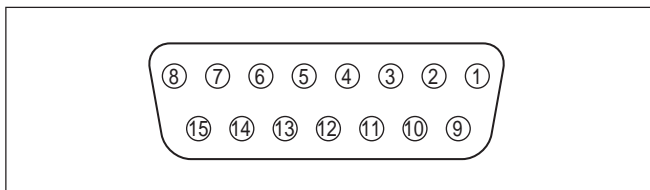

No.	Signal name	Description
1	AUX-RX (X)	Contact your Sony dealer or a Sony service representative.
9	AUX-TX (X)	
2	AUX/TALLY (G)	Gnd (AUX, tally)
10	G TALLY IN	ON: Gnd
3	R TALLY IN	OFF: Open
11	4W (G) IN	4-wire talk, 0 dBu ^{a)} , balanced
4	4W (X) IN	
12	4W (Y) IN	
5	2W (X) IN/OUT	2-wire, 0 dBu ^{a)}
13	2W (G) IN/OUT	Termination required (recommended termination impedance: 600 ohms)
6	RTS (G) IN/OUT	2-wire 0 dBu ^{a)}
14	RTS (X) IN/OUT	Termination required (recommended termination impedance: 200 ohms)
7	4W (Y) OUT	4-wire receive, 0 dBu ^{a)} , balanced
15	4W (G) OUT	
8	4W (X) OUT	

a) 0 dBu = 0.775 V_{rms}

10 MIC OUT (microphone output) connector (XLR, 3-pin)

Outputs microphone signals from the camera/camcorder.

11 PROMPTER VIDEO IN and OUT connectors (BNC type)

Input and output connectors for prompter signals. The IN and OUT connectors have a loop-through configuration, with the signal input to the IN connector being directly output from the OUT connector. The OUT connector is terminated automatically when nothing is connected to it.

12 GENLOCK IN and OUT connectors (BNC type)

The IN connector accepts a reference video signal (black burst or composite video) for external sync. The IN and OUT connectors have a loop-through configuration, with the signal input to the IN connector being directly output from the OUT connector. The OUT connector is terminated automatically when nothing is connected to it.

13 Spare connector

This is a spare connector, not currently used.

14 SYNC OUTPUT connector (BNC type)

Outputs a sync signal from the camera/camcorder.

15 MONITOR OUTPUT connector (BNC type)

Outputs composite video signals for a monitor. When you press the MENU button and the SELECT up and down buttons on the front panel of this unit, information about system settings is superimposed over the video signals output from this connector.

Displaying and Changing Settings

Displaying Settings

When the MENU button on the front panel is unlit, the SELECT up and down buttons can be used to display automatic adjustment items and the current state of the CCU-D50/D50P on a monitor connected to the MONITOR OUT connector. The SELECT up and down buttons can also be used to change pages.

Initial page

The initial page appears immediately after the unit is powered on. Nothing is displayed on the initial page.

Page 1: Normal page

Page 1 displays the current settings of the camera/camcorder.

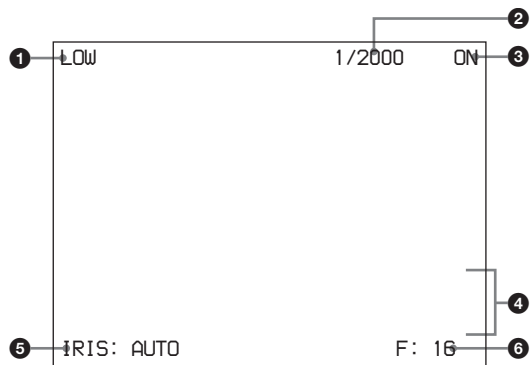

No.	Item	Value
1	Master gain	LOW/MID/HIGH ^{a)}
2	Shutter/clear scan speed	When the SHUTTER switch is set to SHUTTER: 1/100 to 1/2000 (NTSC), 1/60 to 1/2000 (PAL) When the SHUTTER Switch is set to CLEAR SCAN: 60.4 Hz to 200.3 Hz (NTSC), 50.3 Hz to 201.4 Hz (PAL) When EVS is set to ON: EVS When TLCS is set to ON: TLCS
3	Shutter on/off	ON/OFF
4	AWB/ABB progress and result	1st line: AWB (automatic white balance adjustment) or ABB (automatic black balance adjustment) 2nd line: Progress of adjustment 3rd line: Result of adjustment
5	Iris mode	AUTO/MANUAL
6	F value	CLOSE, F:1.4 to F:16

a) A GAIN value is displayed during operations on RCP-TX7.

Note

The F value does not appear when the CCU command mode (see “16 System setting switches” on page 18) is set to off (M5A mode).

Page 2: Control page

Page 2 displays the control settings made on this unit or from the connected control device.

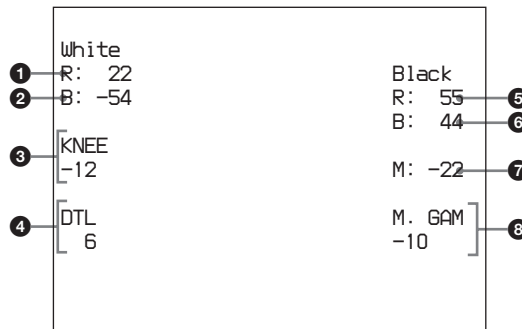

No.	Setting item
1	White balance - red
2	White balance - blue
3	Knee adjustment
4	Detail
5	Black balance - red
6	Black balance - blue
7	Master black
8	Master gamma

When the WHITE/BLACK BALANCE switch (see page 16) is set to AUTO or PRESET, AUTO or PRESET appears instead of a numeric value.

Note

The master gamma value does not appear when the CCU command mode (see “16 System setting switches” on page 18) is set to off (M5A mode).

Displaying and Changing Settings

Page 3 System Setting page

Page 3 displays the current settings of the system including this unit, made by the system setting switches and intercom setting switches (see page 19) on the front panel of this unit.

System Settings		
1	COMMAND MODE	TX7
2	RETURN	COLOR
3	DIGITAL TRANS	OFF
4	OUTPUT	R/G/B
5	COMMAND	LOCAL
6	INTERCOM	4W

Settings by system setting switches

No.	Description	Value
1	CCU command mode (switch 1)	M5A, TX7
2	Return signal mode (switch 2)	COLOR, B/W
3	Digital transmission (switch 3)	ON, OFF
4	Output mode (switches 4 and 5)	Y/C, R/G/B, Y/B-Y/R-Y
5	Remote/local (switch 6)	REMOTE, LOCAL

Settings by intercom setting switches

No.	Description	Value	Intercom setting switch number
6	Intercom mode setting	4W, 2W, RTS, CLEARCOM	1, 2, 3

Page 4: System Setting page

Page 4 displays the current settings of the system including this unit, made on the front panel of this unit.

System Settings		
1	Cable Comp	100m
2	H-Phase	12
3	SC-Phase	-22
4	0/180	0

No.	Description	Value
1	Cable compensation value	25/50/75/100/150/200/250/300 m
2	Horizontal phase adjustment value	-99 to 99
3	Subcarrier phase fine adjustment value	-99 to 99
4	Subcarrier phase adjustment	0/180

Page 5: Diagnosis page

Page 5 displays the results of CCU-D50/D50P self-diagnostics.

Diagnosis		
1	CAMERA Sync	OK
2	COMMAND CAMERA	OK
3	RCP	OK
4	FAN	OK
5	SYSTEM	OK
6	MEMORY	OK
7	PANEL	OK
8	CCU SDI IN	IN

No.	Description	Value
1	Whether sync is being input from camera	OK, NO
2	Status of Command Link with camera	OK, NO
3	Status of Command Link with remote control panel/unit	OK, NO
4	Status of power fan	OK, NG
5	Other CPU status	OK, NG
6	Status of front panel status memory	OK, NG
7	Status of connection with rear panel	OK, NG
8	Presence of SDI input from CCU	IN, NO

Page 6: CA Setting (CA-D50 settings) page

Page 6 displays the current settings of CA-D50. Nothing is displayed when a CA-D50 is not connected, when a camcorder is in use, and when the CCU command mode (see “16 System setting switches” on page 18) is set to off (M5A mode).

CA Settings		
1	SDI PLL	OK
2	CABLE COMP	ON
3	RETURN	COLOR
4	SKIN GATE	ON
5	OUTPUT	R/G/B

No.	Description	Value
①	CA SDI PLL status	OK, NG
②	200 m (656 feet) cable compensation setting	ON, OFF
③	Return signal mode	COLOR, B/W
④	SKIN-GATE MIX function setting	ON, OFF
⑤	Output mode setting	Y/C, R/G/B, Y/B-Y/R-Y

Changing Settings

When the MENU button on the front panel is lit, a menu appears on the monitor connected to the MONITOR OUT connector, allowing you to change the settings of the system including this unit.

To operate the menu

Proceed as follows.

- 1 Press the MENU button on the front panel, turning it on.

A menu appears on the monitor connected to the MONITOR OUT connector.

- 2 Press the SELECT up or down button to select a page, and then press the ENTER button.
- 3 Press the SELECT up or down button to select a menu item, and then press the ENTER button.
- 4 Press the SELECT up or down button to select a setting for the item, and then press the ENTER button.

Press the CANCEL button to return to the previous state.

Page1: Setup Menu page

This page controls camera/camcorder and CCU functions.

Setup Menu		
①	MATRIX	: STANDARD
②	IRIS	: STANDARD
③	EVS	: OFF
④	TITLE	: OFF
⑤	CLOCK	: OFF
⑥	RCP RATE	: 38400
⑦	TLCS	: OFF
⑧	SKIN DTL	: OFF

No.	Function	Settings	Factory default setting
①	Switch color matrix function. ^{a)}	STANDARD, COLORFUL, FL LIGHT	STANDARD
②	Switch AUTO IRIS mode.	STANDARD, SPOT 1., BACK 1.	STANDARD
③	Turn EVS on and off.	ON, OFF	OFF
④	Turn TITLE display on and off.	ON, OFF	OFF
⑤	Turn time display on and off. ^{b)}	CAM, BARS, OFF	OFF
⑥	Set communications speed for REMOTE connector on the rear panel. ^{c)}	38400, 9600	38400
⑦	Turn TLCS function on and off. ^{d)}	ON, OFF	OFF
⑧	Turn skin detail function on and off. ^{d)}	ON, OFF	OFF

- This can also be set for the DXC-D35/D35WS series, but the setting is ignored.
- When the CCU command mode (see “16 System setting switches” on page 18) is set to on (TX7 mode), the selections for this item are CAM, BARS, and OFF. When the CCU command mode is set to off (M5A mode), the selections for this item are ON and OFF. For details, refer to the operation manual of the camera/camcorder.
- Always select 38400 when a RCP-TX7 (not available in EU countries) is connected. Selecting anything other than 38400 will prevent a connection from being made.
- This item does not appear when the CCU command mode is set to off (M5A mode).

Displaying and Changing Settings

Page 2: Volume PRESET page

This page allows you to set the control values for the center click positions of the knobs on the front panel of this unit to 0 or to the factory default values.

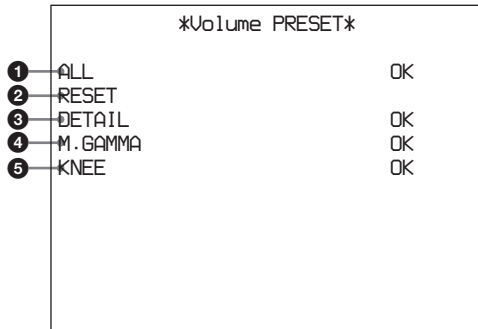

No.	Description
1	Sets the control values of all knobs to 0.
2	Returns all knobs to the factory default control values.
3	Sets the control value of the DETAIL knob only to 0.
4	Sets the control value of the MASTER GAMMA knob only to 0.
5	Sets the control value of the KNEE knob only to 0.

To set center values

Proceed as follows.

- 1 Press the SELECT up and down buttons to select the menu item for the knob that you want to adjust.
- 2 Rotate the knob for the item selected in step 1 to the center click position.
- 3 Press the ENTER button.

The control value for the center click position is set to 0.

Notes on Use

Use and storage locations

Avoid using or storing the unit in the following places:

- Where it is subject to extremes of temperature.
- Near a heat source, such as a radiator or an air duct, or in a place subject to direct sunlight. (Note that in summer the temperature in a car with the windows closed can reach 50°C (122°F).)
- Very damp or dusty places.
- Where rain is likely to reach the unit.
- Places subject to severe vibration.
- Near strong magnetic fields.
- Near transmitting stations generating strong radio waves.

Avoid violent impacts

Dropping the unit, or otherwise imparting a violent shock to it, is likely to cause it to malfunction.

Do not cover with cloth

While the unit is in operation, do not cover it with a cloth or other material. This can cause the temperature to rise, leading to a malfunction.

After use

Turn the unit off.

Care

If the body of the unit is dirty, wipe it with a dry cloth. For severe dirt, use a soft cloth steeped in a small amount of neutral detergent, then wipe dry. Do not use volatile solvents such as alcohol or thinners, as these may damage the finish.

Regarding the transport of this unit

Keep the original carton and associated packing material, and use them when transporting the unit. During transport, do not subject the unit to strong shocks.

Specifications

General

Power requirements

CCU-D50: 100 to 120 V AC,
60 Hz
CCU-D50P: 220 to 240 V AC,
50 Hz

Power consumption

CCU-D50: 1.7 A (entire system
operating, 100 to 120 V AC)
CCU-D50P: 0.8 A (entire system
operating, 220 to 240 V AC)

Peak inrush current

(1) Power ON, current probe
method: 20A (240V), 6A (100 V)
(2) Hot switching inrush current,
measured in accordance with
European standard EN 55103-1:
12A (230 V)

Rated maximum load to camera

4 A, 13 V (at receiving end)

Operating temperature

5°C to 40°C (41°F to 104°F)

Storage temperature

-20°C to +55°C (-4°F to +131°F)

Dimensions (w/h/d, excluding protrusions)

424 × 88 × 283 mm (16 3/4 × 3 1/2 ×
11 1/4 inches)

Mass

Approx. 6.3 kg (13 lb 14 oz)

Output connectors

VBS OUT 1/2

BNC type (1 each)
VBS: 1.0 Vp-p, negative-sync,
75 Ω, unbalanced

S VIDEO

Mini DIN 4-pin (1)
Y: 1.0 Vp-p, negative-sync, 75 Ω,
unbalanced
C: 0.286 Vp-p (burst), no sync

Y/G/Y, R-Y/R/C, B-Y/B

BNC type (1 each) (switchable)
R, G, B: 0.7 Vp-p, 75 Ω, no sync
Y: 1.0 Vp-p, negative-sync, 75 Ω,
unbalanced
R-Y, B-Y: 0.700 Vp-p (CCU-D50)
or 0.525 Vp-p (CCU-D50P), no
sync, 75 Ω, unbalanced
Y: 1.0 Vp-p, negative-sync, 75 Ω,
unbalanced
C: 0.286 Vp-p (burst), no sync

SYNC OUT

BNC type (1)
0.3 Vp-p, negative-sync, 75 Ω,
unbalanced

MONITOR OUT

BNC type (1)
VBS: 1.0 Vp-p, negative-sync,
75 Ω, unbalanced

MIC OUT

XLR 3-pin (male) (1)

SDI OUT 1/2

BNC type (1 each)
0.8 Vp-p, 75 Ω, 270 Mbps

Input connectors

GENLOCK IN/OUT

BNC type (1 each)
VBS: 1.0 Vp-p or black burst (0.45
Vp-p), loop-through, 75 Ω
automatic termination

CAMERA

Z type 26-pin (1)

TALLY/INTERCOM/AUX

D-sub 15-pin (1)

INTERCOM

Mini-jack (1)

SDI IN

BNC type (1)
0.8 Vp-p, 75 Ω, 270 Mbps

REMOTE

10-pin (1)

RETURN VIDEO IN/OUT

BNC type (1 each)
VBS (1.0 Vp-p), loop-through,
75 Ω automatic termination

PROMPTER VIDEO IN/OUT

BNC type (1 each)
VBS (1.0 Vp-p), loop-through,
75 Ω automatic termination

Adjustable items

Iris

Automatic/manual

White balance

Automatic/manual/preset
R, B output levels adjustable
Automatic tracking

Black balance

Automatic/manual
R, B black levels adjustable

Video amplifier gain level

Master black level

Knee point Automatic/manual

Detail level

Gamma compensation

Electronic shutter speed

Clear Scan

Specifications

Video output signal selection
 Camera/color bars
Tally/intercom level
SC phase
H phase
Cable compensation

Design and specifications are subject to change without notice.

If you wish to use the INTERCOM/TALLY/AUX connector, be sure to consult your Sony dealer or a Sony service representative.
--

Accessories supplied

Rack mount brackets (2)
Screws for rack mounting (4)
AC power cord (1)
Camera number plates (1 set)
DIP switch label (1)
SDI switch label (1)
Operating Instructions (1)
CD-ROM Manual (1)
Warranty card (1)

Optional accessories

Color video camera
 DXC-D35/D35P, DXC-D35WS/
 D35WSP
Camera adaptor CA-D50
DV camcorder DSR-370/370P, DSR-570WS/
 570WSP

Studio system devices

Remote control unit
 RCP-TX7 (not available in EU
 countries), RM-M7G
Headset DR-100
Camera cable CCZ-A2 (2 meters, about 7 feet),
 CCZ-A5 (5 meters, about 17
 feet), CCZ-A10 (10 meters, about
 33 feet), CCZ-A25 (25 meters,
 about 83 feet), CCZ-A50 (50
 meters, about 166 feet), CCZ-
 A100 (100 meters, about 333
 feet)
Extension connector for CCZ-A series camera cable
 CCZZ-1B (fixed on wall), CCZZ-
 1E

Free Manuals Download Website

<http://myh66.com>

<http://usermanuals.us>

<http://www.somanuals.com>

<http://www.4manuals.cc>

<http://www.manual-lib.com>

<http://www.404manual.com>

<http://www.luxmanual.com>

<http://aubethermostatmanual.com>

Golf course search by state

<http://golfingnear.com>

Email search by domain

<http://emailbydomain.com>

Auto manuals search

<http://auto.somanuals.com>

TV manuals search

<http://tv.somanuals.com>