

MDS-JE330

SERVICE MANUAL



*US Model
Canadian Model
AEP Model
UK Model
E Model
Australian Model*



US and foreign patents licensed from Dolby Laboratories Licensing Corporation.

Model Name Using Similar Mechanism	MDS-JE520
MD Mechanism Type	MDM-5A
Optical Pick-up Type	KMS-260A/J1N

SPECIFICATIONS

System	MiniDisc digital audio system	Frequency response	5 to 20,000 Hz \pm 0.3 dB
Disc	MiniDisc	Signal-to-noise ratio	Over 94 dB during playback
Laser	Semiconductor laser ($\lambda = 780$ nm) Emission duration: continuous	Wow and flutter	Below measurable limit
Laser output	Less than 44.6 μ W* * This output is the value measured at a distance of 200 mm from the objective lens surface on the Optical Pick-up Block with 7 mm aperture.	Inputs	
Laser diode	Material: GaAlAs	LINE (ANALOG) IN	Jack type: phono Impedance: 47 kilohms Rated input: 500 mVrms Minimum input: 125 mVrms
Revolutions (CLV)	400 rpm to 900 rpm	DIGITAL (OPTICAL) IN	Connector type: square optical Impedance: 660 nm (optical wave length)
Error correction	Advanced Cross Interleave Reed Solomon Code (ACIRC)	Outputs	
Sampling frequency	44.1 kHz	LINE (ANALOG) OUT	Jack type: phono Rated output: 2 Vrms (at 50 kilohms) Load impedance: Over 10 kilohms
Coding	Adaptive Transform Acoustic Coding (ATRAC)		
Modulation system	EFM (Eight-to-Fourteen Modulation)		
Number of channels	2 stereo channels		

— Continued on next page —

MINIDISC DECK



SONY®

General

Power requirements

Where purchased	Power requirements
U.S.A. and Canada	120 V AC, 60 Hz
U.K. and Continental Europe	220 - 230 V AC, 50/60 Hz
Australia	240 V AC, 50/60 Hz
Certain countries in Asia	220 - 240 V AC, 50/60 Hz
Other countries	110 - 120 or 220 - 240 V AC selectable, 50/60 Hz

Power consumption 22 W

Dimensions (approx.) 430 × 95 × 290 mm (17 × 3³/₄ × 11¹/₂ inches) (w/h/d) incl. projecting parts and controls

Mass (approx.) 3.5 kg (7 lb 20 oz)

Supplied accessories

- Audio connecting cords (2)
- Optical cable (1)
- Remote commander (remote) RM-D29M (1)
- R6 (size-AA) batteries (2)

Design and specifications are subject to change without notice.

SELF-DIAGNOSIS FUNCTION

The self-diagnosis function consists of error codes for customers which are displayed automatically when errors occur, and error codes which show the error history in the test mode during servicing. For details on how to view error codes for the customer, refer to the following box in the instruction manual. For details on how to check error codes during servicing, refer to the following "Procedure for using the Self-Diagnosis Function (Error History Display Mode)".

Self-Diagnosis Function

The deck's self-diagnosis function automatically checks the condition of the MD deck when an error occurs, then issues a three-digit code and an error message on the display. If the code and message alternate, find them in the following table and perform the indicated countermeasure. Should the problem persist, consult your nearest Sony dealer.

Three-digit code/Message	Cause/Remedy
C11/Protected	The inserted MD is record-protected. → Take out the MD and close the record-protect slot (page 15).
C13/REC Error	The recording was not made properly. → Set the deck in a stable surface, and repeat the recording procedure. The inserted MD is dirty (with smudges, fingerprints, etc.), scratched, or substandard in quality. → Replace the disc and repeat the recording procedure.
C13/Read Error	The deck could not read the TOC on the MD properly. → Take out the MD and insert it again.
C14/TOC Error	The deck could not read the TOC on the MD properly. → Insert another disc. → If possible, erase all the tracks on the MD (page 30).
C71/Din Unlock	The sporadic appearance of this message is caused by the digital signal being recorded. This will not affect the recording. While recording from a digital component connected through the DIGITAL (OPTICAL) IN connector, the digital connecting cable was unplugged or the digital component turned off. → Connect the cable or turn the digital component back on.

Procedure for using the Self-Diagnosis Function (Error History Display Mode).

Note: Perform the self-diagnosis function in the "error history display mode" in the test mode. The following describes the least required procedure. Be careful not to enter other modes by mistake. If you set other modes accidentally, press the **MENU/NO** button to exit the mode.

1. While pressing the **AMS** knob and **■** button, connect the power plug to the outlet, and release the **AMS** knob and **■** button.
2. Rotate the **AMS** knob and when "[Service]" is displayed, press the **YES** button.
3. Rotate the **AMS** knob and display "ERR DP MODE".
4. Pressing the **YES** button sets the error history mode and displays "total rec".
5. Select the contents to be displayed or executed using the **AMS** knob.
6. Pressing the **AMS** knob will display or execute the contents selected.
7. Pressing the **AMS** knob another time returns to step 4.
8. Pressing the **MENU/NO** button displays "ERROR DP MODE" and exits the error history mode.
9. To exit the test mode, press the **REPEAT** button. The unit sets into the STANDBY state, the disc is ejected, and the test mode ends.

ITEMS OF ERROR HISTORY MODE ITEMS AND CONTENTS

Selecting the Test Mode

Display	Details of History
total rec	Displays the recording time. Displayed as "r□□□□□h". The displayed time is the total time the laser is set to the high power state. This is about 1/4 of the actual recording time. The time is displayed in decimal digits from 0h to 65535h.
total play	Displays the play time. Displayed as "p□□□□□h". The time displayed is the total actual play time. Pauses are not counted. The time is displayed in decimal digits from 0h to 65535h.
retry err	Displays the total number of retries during recording and number of retry errors during play. Displayed as "r□□ p□□". "r" indicates the retries during recording while "p" indicates the retry errors during play. The number of retries and retry errors are displayed in hexadecimal digits from 00 to FF.
total err	Displays the total number of errors. Displayed as "total □□". The number of errors is displayed in hexadecimal digits from 00 to FF.
err history	Displays the 10 latest errors. Displayed as "0□ E@@". □ indicates the history number. The smaller the number, the more recent is the error. (00 is the latest). @@ indicates the error code. Refer to the following table for the details. The error history can be switched by rotating the [AMS] knob.
er refresh	Mode which erases the "retry err", "total err", and "err history" histories. When returning the unit to the customer after completing repairs, perform this to erase the past error history. After pressing the [AMS] button and "er refresh?" is displayed, press the [YES] button to erase the history. "Complete!" will be displayed momentarily. Be sure to check the following when this mode has been executed. <ul style="list-style-type: none"> • The data has been erased. • The mechanism operates normally when recording and play are performed.
tm refresh	Mode which erases the "total rec" and "total play" histories. These histories serve as approximate indications of when to replace the optical pickup. If the optical pickup has been replaced, perform this operation and erase the history. After pressing the [AMS] button and "tm refresh?" is displayed, press the [YES] button to erase the history. "Complete!" will be displayed momentarily. Be sure to check the following when this mode has been executed. <ul style="list-style-type: none"> • The data has been erased. • The mechanism operates normally when recording and play are performed.

Table of Error Codes

Error Code	Details of Error	Error Code	Details of Error
E00	No error	E05	FOK has deviated
E01	Read error. PTOC cannot be read (DISC ejected)	E06	Cannot focus (Servo has deviated)
		E07	Recording retry
E02	TOC error. UTOC error (DISC not ejected)	E08	Recording retry error
		E09	Playback retry error (Access error)
E03	Loading error	E0A	Play retry error (C2 error)
E04	Address cannot be read (Servo has deviated)		

CAUTION

Danger of explosion if battery is incorrectly replaced.
Replace only with the same or equivalent type recommended by the equipment manufacturer.
Discard used batteries according to manufacture's instructions.

ADVARSEL!

Lithiumbatteri - Eksplosionsfare ved fejlagtig håndtering.
Udskiftning må kun ske med batteri af samme fabrikat og type.
Levér det brugte batteri tilbage til leverandøren.

ADVARSEL

Eksplosjonsfare ved feilaktig skifte av batteri.
Benytt samme batteritype eller en tilsvarende type anbefalt av apparatfabrikanten.
Brukte batterier katterier kasseres i henhold til fabrikantens

VARNIG

Explosionsfara vid felaktigt batteribyte.
Använd samma batterityp eller en likvärdig typ som rekommenderas av apparattillverkaren.
Kassera använt batteri enligt gällande föreskrifter.

VAROITUS

Parist voi räjähtää, jos se on virheellisesti asennettu.
Vaihda paristo ainoastaan laitevalmistajan suosittelemaan tyyppiin.
Hävitätä käytetty paristo valmistajan ohjeiden mukaisesti.

Laser component in this product is capable of emitting radiation exceeding the limit for Class 1.

CLASS 1 LASER PRODUCT
LUOKAN 1 LASERLAITE
KLASS 1 LASERAPPARAT

This appliance is classified as a CLASS 1 LASER product. The CLASS 1 LASER PRODUCT MARKING is located on the rear exterior.

CAUTION : INVISIBLE LASER RADIATION WHEN OPEN AND INTERLOCKS DEFEATED. AVOID EXPOSURE TO BEAM.
ADVARSEL : USYNLIG LASERSTRÅLING VED ÅBNING NÅR SIKKERHEDSafbrydere er ude af funktion. undgå udsættelse for stråling.
VORSICHT : UNSICHTBARE LASERSTRAHLUNG. WENN ABDECKUNG GEÖFFNET UND SICHERHEITSSVERRIEGELUNG ÜBERBRÜCKT. NICHT DEM STRAHL AUSSETZEN.
VARO! : AVATTAESSA JA SUOJALUKITUS OHITETTAESSA OLET ALT-TIINA NÄKYMÄTTÖMÄLLE LASERÄTEILYLLE. ÄLÄ KATSO SÄTEESEEN.
VARNING : OSYNLIG LASERSTRÅLING NÅR DENNA DEL ÄR ÖPPNAD OCH SPÄRREN ÄR URKOPPLAD. BETRÄKTA EJ STRÅLEN.
ADVERSEL : USYNLIG LASERSTRÅLING NÅR DEKSEL ÅPNES OG SIKKERHEDSLÅS BRYTES. UNNGÅ EKSPONERING FOR STRÅLEN.
VIGYAZAT! : A BURKOLAT NYITÁSAKOR LÁTHATATLAN LÉZERSUGÁRVESZÉLY! KERÜLJE A BESUGÁRZÁST!

This caution label is located inside the unit.

CAUTION

Use of controls or adjustments or performance of procedures other than those specified herein may result in hazardous radiation exposure.

Notes on chip component replacement

- Never reuse a disconnected chip component.
- Notice that the minus side of a tantalum capacitor may be damaged by heat.

Flexible Circuit Board Repairing

- Keep the temperature of soldering iron around 270°C during repairing.
- Do not touch the soldering iron on the same conductor of the circuit board (within 3 times).
- Be careful not to apply force on the conductor when soldering or unsoldering.

SAFETY-RELATED COMPONENT WARNING !!

COMPONENTS IDENTIFIED BY MARK \triangle OR DOTTED LINE WITH MARK \triangle ON THE SCHEMATIC DIAGRAMS AND IN THE PARTS LIST ARE CRITICAL TO SAFE OPERATION. REPLACE THESE COMPONENTS WITH SONY PARTS WHOSE PART NUMBERS APPEAR AS SHOWN IN THIS MANUAL OR IN SUPPLEMENTS PUBLISHED BY SONY.

ATTENTION AU COMPOSANT AYANT RAPPORT À LA SÉCURITÉ!!

LES COMPOSANTS IDENTIFIÉS PAR UNE MARQUE \triangle SUR LES DIAGRAMMES SCHÉMATIQUES ET LA LISTE DES PIÈCES SONT CRITIQUES POUR LA SÉCURITÉ DE FONCTIONNEMENT. NE REMPLACER CES COMPOSANTS QUE PAR DES PIÈCES SONY DONT LES NUMÉROS SONT DONNÉS DANS CE MANUEL OU DANS LES SUPPLÉMENTS PUBLIÉS PAR SONY.

SAFETY CHECK-OUT

After correcting the original service problem, perform the following safety checks before releasing the set to the customer:
Check the antenna terminals, metal trim, "metallized" knobs, screws, and all other exposed metal parts for AC leakage. Check leakage as described below.

LEAKAGE

The AC leakage from any exposed metal part to earth Ground and from all exposed metal parts to any exposed metal part having a return to chassis, must not exceed 0.5 mA (500 microamperes). Leakage current can be measured by any one of three methods.

1. A commercial leakage tester, such as the Simpson 229 or RCA WT-540A. Follow the manufacturers' instructions to use these instruments.
2. A battery-operated AC milliammeter. The Data Precision 245 digital multimeter is suitable for this job.
3. Measuring the voltage drop across a resistor by means of a VOM or battery-operated AC voltmeter. The "limit" indication is 0.75 V, so analog meters must have an accurate low-voltage scale. The Simpson 250 and Sanwa SH-63Trd are examples of a passive VOM that is suitable. Nearly all battery operated digital multimeters that have a 2V AC range are suitable. (See Fig. A)

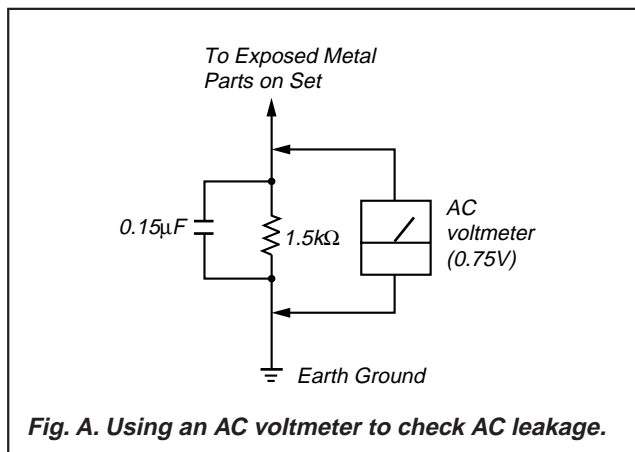

MODEL IDENTIFICATION — BACK PANEL —

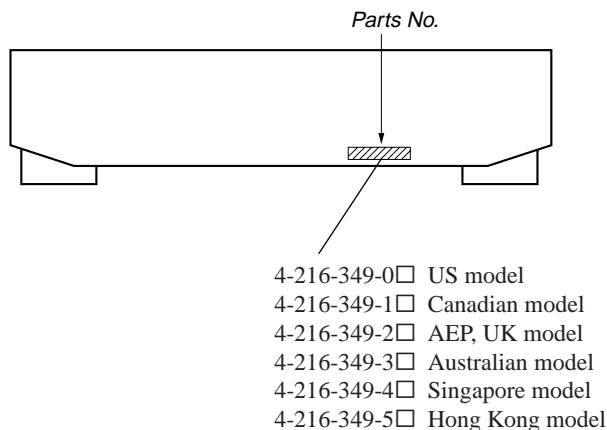

TABLE OF CONTENTS

1. SERVICING NOTE	6
2. GENERAL	11
3. DISASSEMBLY	
3-1. Case and Front Panel	12
3-2. Slider (Cam)	12
3-3. Base Unit (MBU-5A) and BD Board	13
3-4. SW Board and Loading Motor (M103)	13
4. TEST MODE	14
5. ELECTRICAL ADJUSTMENTS	19
6. DIAGRAMS	
6-1. Circuit Boards Location	28
6-2. Block Diagrams	
• BD Section	29
• Main Section	31
6-3. Printed Wiring Board – BD Section –	35
6-4. Schematic Diagram – BD Section – (1/2)	37
Schematic Diagram – BD Section – (2/2)	39
6-5. Schematic Diagram – Main Section – (1/2)	41
Schematic Diagram – Main Section – (2/2)	43
6-6. Printed Wiring Board – Main Section –	45
6-7. Printed Wiring Board – Panel Section –	47
6-8. Schematic Diagram – Panel Section –	49
6-9. Schematic Diagram – BD Switch Section –	51
6-10. Printed Wiring Board – BD Switch Section –	51
6-11. IC Block Diagrams	52
6-12. IC Pin Functions	55
7. EXPLODED VIEWS	
7-1. Case and Back Panel Section	61
7-2. Front Panel Section	62
7-3. Mechanism Section (MDM-5A)	63
7-4. Base Unit Section (MBU-5A)	64
8. ELECTRICAL PARTS LIST	65

SECTION 1 SERVICING NOTE

JIG FOR CHECKING BD BOARD WAVEFORM

The special jig (J-2501-149-A) is useful for checking the waveform of the BD board. The names of terminals and the checking items to be performed are shown as follows.

- GND : Ground
- I+3V : For measuring IOP (Check the deterioration of the optical pick-up laser)
- IOP : For measuring IOP (Check the deterioration of the optical pick-up laser)
- TEO : TRK error signal (Traverse adjustment)
- VC : Reference level for checking the signal
- RF : RF signal (Check jitter)

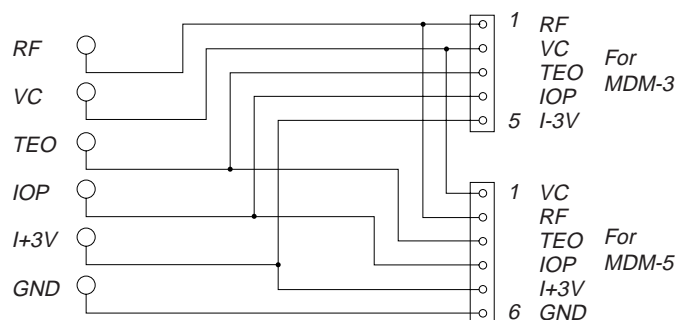
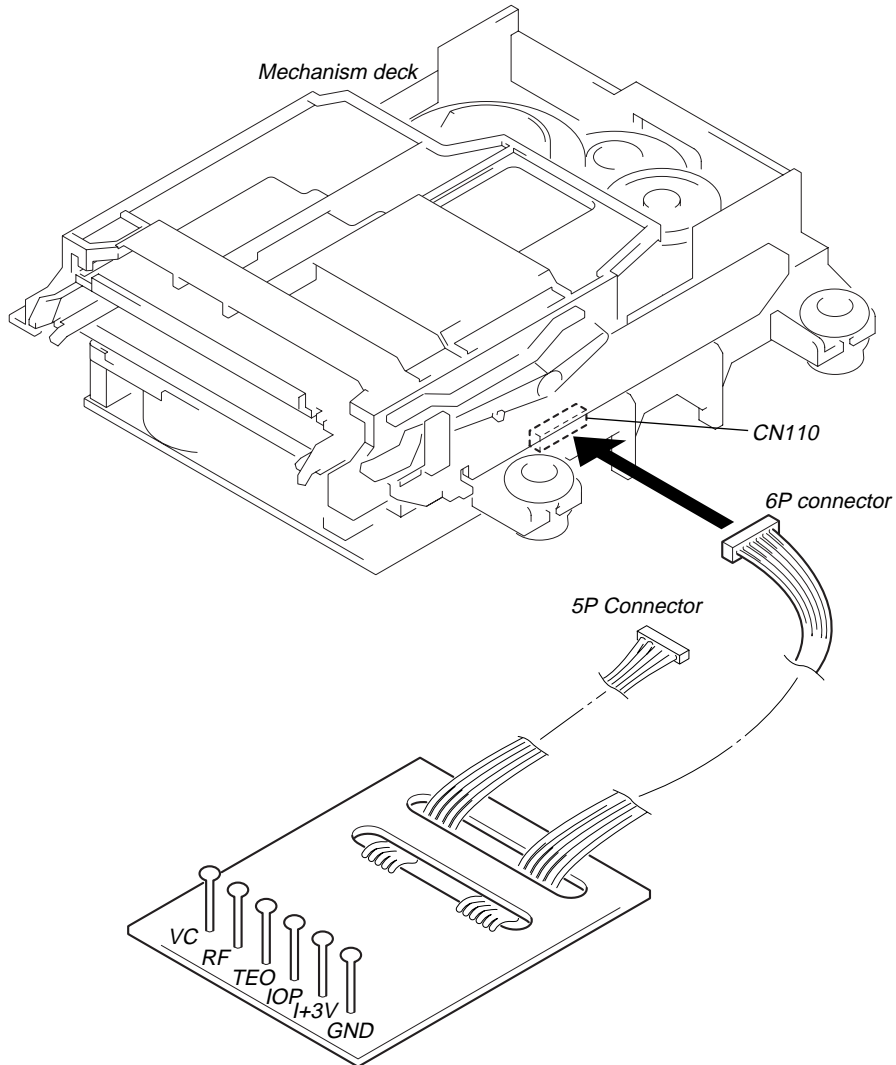

IOP DATA RECORDING AND DISPLAY WHEN OPTICAL PICK-UP AND NON-VOLATILE MEMORY (IC171 OF BD BOARD) ARE REPLACED

The IOP value labeled on the optical pick-up can be recorded in the non-volatile memory. By recording the value, it will eliminate the need to look at the value on the label of the optical pick-up. When replacing the optical pick-up or non-volatile memory (IC171 of BD board), record the IOP value on the optical pick-up according to the following procedure.

Record Procedure:

1. While pressing the **AMS** knob and **■** button, connect the power plug to the outlet, and release the **AMS** knob and **■** button.
2. Rotate the **AMS** knob to display “[Service]”, and press the **YES** button.
3. Rotate the **AMS** knob to display “Iop.Write”, and press the **YES** button.
4. The display becomes “Ref=@@.@” (@ is an arbitrary number) and the numbers which can be changed will blink.
5. Input the IOP value written on the optical pick-up.
To select the number : Rotate the **AMS** knob.
To select the digit : Press the **AMS** knob.
6. When the **YES** button is pressed, the display becomes “Measu=@@.@” (@ is an arbitrary number).
7. As the adjustment results are recorded for the 6 value. Leave it as it is and press the **YES** button.
8. “Complete!” will be displayed momentarily. The value will be recorded in the non-volatile memory and the display will become “Iop Write”.
9. Press the **REPEAT** button to complete.

Display Procedure:

1. While pressing the **AMS** knob and **■** button, connect the power plug to the outlet, and release the **AMS** knob and **■** button.
2. Rotate the **AMS** knob to display “[Service]”, and press the **YES** button.
3. Rotate the **AMS** knob to display “Iop.Read”.
4. “@.@./##.#” is displayed and the recorded contents are displayed.
@.@. : indicates the Iop value labeled on the pick-up.
##.# : indicates the Iop value after adjustment
5. To end, press the **AMS** button or **MENU/NO** button to display “Iop Read”. Then press the **REPEAT** button.

CHECKS PRIOR TO PARTS REPLACEMENT AND ADJUSTMENTS

Before performing repairs, perform the following checks to determine the faulty locations up to a certain extent. Details of the procedures are described in “5 Electrical Adjustments”.

	Criteria for Determination (Unsatisfactory if specified value is not satisfied)	Measure if unsatisfactory:
Laser power check (5-6-2 : See page 21)	<ul style="list-style-type: none"> 0.9 mW power Specified value : 0.84 to 0.92 mW 7.0 mW power Specified value : 6.8 to 7.2 mW 	<ul style="list-style-type: none"> Clean the optical pick-up Adjust again Replace the optical pick-up
	<ul style="list-style-type: none"> Iop (at 7mW) Labeled on the optical pickup Iop value \pm 10mA 	<ul style="list-style-type: none"> Replace the optical pick-up
Traverse check (5-6-3 : See page 21)	<ul style="list-style-type: none"> Traverse waveform Specified value : Below 10% offset 	<ul style="list-style-type: none"> Replace the optical pick-up
Focus bias check (5-6-4 : See page 22)	<ul style="list-style-type: none"> Error rate check Specified value : For points a, b, and c C1 error : Below 220 AD error : Below 2 	<ul style="list-style-type: none"> Replace the optical pick-up
C PLAY check (5-6-5 : See page 22)	<ul style="list-style-type: none"> Error rate check Specified value: a. When using test disc (MDW-74/AU-1) C1 error : Below 80 AD error : Below 2 b. When using check disc (TDYS-1) C1 error : Below 50 	<ul style="list-style-type: none"> Replace the optical pick-up
Self-recording/playback check (REC/PLAY) (5-6-6 : See page 22)	<ul style="list-style-type: none"> CPLAY error rate check Specified value: C1 error : Below 80 AD error : Below 2 	If always unsatisfactory: <ul style="list-style-type: none"> Replace the overwrite head Check for disconnection of the circuits around the overwrite head
		If occasionally unsatisfactory: <ul style="list-style-type: none"> Check if the overwrite head is distorted Check the mechanism around the sled
TEMP check (Temperature compensation offset check) (5-6-1 : See page 21)	<ul style="list-style-type: none"> Unsatisfactory if displayed as T=@@ (##) [NG]” NG (@@, ## are both arbitrary numbers) 	<ul style="list-style-type: none"> Check for disconnection of the circuits around D101 (BD board) Check the signals around IC101, IC121, CN102, CN103 (BD board)

Note:

The criteria for determination above is intended merely to determine if satisfactory or not, and does not serve as the specified value for adjustments.

When performing adjustments, use the specified values for adjustments.

FORCED RESET

The system microprocessor can be reset in the following procedure.

Use these procedure when the unit cannot be operated normally due to the overrunning of the microprocessor, etc.

Procedure :

Remove the short-pin attached to CN406, and then attach it again.

[MAIN BOARD] (Component Side)

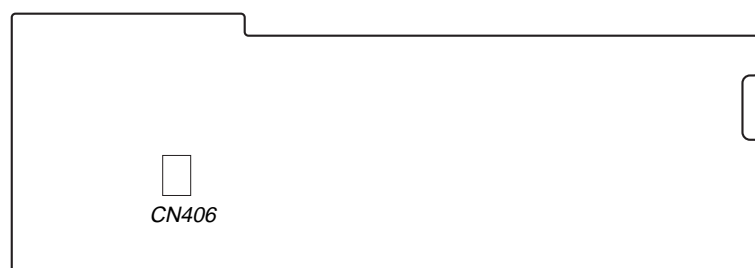

RETRY CAUSE DISPLAY MODE

- In this test mode, the causes for retry of the unit during recording can be displayed on the fluorescent indicator tube. During playback, the “track mode” for obtaining track information will be set. This is useful for locating the faulty part of the unit.
- The following will be displayed :
 - During recording and stop : Retry cause, number of retries, and number of retry errors.
 - During playback : Information such as type of disc played, part played, copyright.
 These are displayed in hexadecimal.

Procedure:









- Procedure 1: Press the  button continuously for about 10 seconds.
 Procedure 2: Press the  button while pressing the  button and  button.
- When the mode is set, “RTs 00c 00e 00” is displayed.
- Press the  button to start recording. Then press the  button and start recording.
- To check the “track mode”, press the  button to start play.
- To exit the test mode, press the  button, and turn OFF the power. When “TOC” disappears, disconnect the power plug from the outlet. If the test mode cannot be exited, refer to “Forced Reset” on page 8.

Fig. 1 Reading the Test Mode Display (During recording and stop)

 Fluorescent display tube display

- @@ : Cause of retry
- ## : Number of retries
- ** : Number of retry errors

Fig. 2 Reading the Test Mode Display (During playback)

 Fluorescent display tube display

- @@ : Parts No. (name of area named on TOC)
- ## : Cluster } Address (Physical address on disc)
- ** : Sector }
- \$\$: Track mode (Track information such as copyright information of each part)

Reading the Retry Cause Display

Hexadecimal	Higher Bits				Lower Bits				Hexadecimal	Cause of Retry	Occurring conditions
	8	4	2	1	8	4	2	1			
Bit	b7	b6	b5	b4	b3	b2	b1	b0			
Binary	0	0	0	0	0	0	0	1	01	shock	When track jump (shock) is detected
	0	0	0	0	0	0	1	0	02	ader5	When ADER was counted more than five times continuously
	0	0	0	0	0	1	0	0	04	Discontinuous address	When ADIP address is not continuous
	0	0	0	0	1	0	0	0	08	DIN unlock	When DIN unlock is detected
	0	0	0	1	0	0	0	0	10	FCS incorrect	When not in focus
	0	0	1	0	0	0	0	0	20	IVR rec error	When ABCD signal level exceeds the specified range
	0	1	0	0	0	0	0	0	40	CLV unlock	When CLV is unlocked
	1	0	0	0	0	0	0	0	80	Access fault	When access operation is not performed normally

Reading the Display:

Convert the hexadecimal display into binary display. If more than two causes, they will be added.

Example

When 42 is displayed:
 Higher bit : 4 = 0100 → b6
 Lower bit : 2 = 0010 → b1
 In this case, the retry cause is combined of “CLV unlock” and “ader5”.

When A2 is displayed:
 Higher bit : A = 1010 → b7+b5
 Lower bit : 2 = 0010 → b2
 The retry cause in this case is combined of “access fault”, “IVR rec error”, and “ader5”.

Reading the Track Mode Display

Hexadecimal	Higher Bits				Lower Bits				Hexa- decimal	Details	
	8	4	2	1	8	4	2	1		When 0	When 1
Bit	b7	b6	b5	b4	b3	b2	b1	b0			
Binary	0	0	0	0	0	0	0	1	01	Emphasis OFF	Emphasis ON
	0	0	0	0	0	0	1	0	02	Monaural	Stereo
	0	0	0	0	0	1	0	0	04	This is 2-bit display. Normally 01.	
	0	0	0	0	1	0	0	0	08	01:Normal audio. Others:Invalid	
	0	0	0	1	0	0	0	0	10	Audio (Normal)	Invalid
	0	0	1	0	0	0	0	0	20	Original	Digital copy
	0	1	0	0	0	0	0	0	40	Copyright	No copyright
	1	0	0	0	0	0	0	0	80	Write prohibited	Write allowed

Reading the Display:

Convert the hexadecimal display into binary display. If more than two causes, they will be added.

Example When 84 is displayed:

Higher bit : 8 = 1000 → b7

Lower bit : 4 = 0100 → b2

In this case, as b2 and b7 are 1 and others are 0, it can be determined that the retry cause is combined of “emphasis OFF”, “monaural”, “original”, “copyright exists”, and “write allowed”.

Example When 07 is displayed:

Higher bit : 0 = 1000 → All 0

Lower bit : 7 = 0111 → b0+b1+b2

In this case, as b0, b1, and b2 are 1 and others are 0, it can be determined that the retry cause is combined of “emphasis ON”, “stereo”, “original”, “copyright exists”, and “write prohibited”.

Hexadecimal → Binary Conversion Table

Hexadecimal	Binary	Hexadecimal	Binary
0	0000	8	1000
1	0001	9	1001
2	0010	A	1010
3	0011	B	1011
4	0100	C	1100
5	0101	D	1101
6	0110	E	1110
7	0111	F	1111

SECTION 2 GENERAL

Front Panel

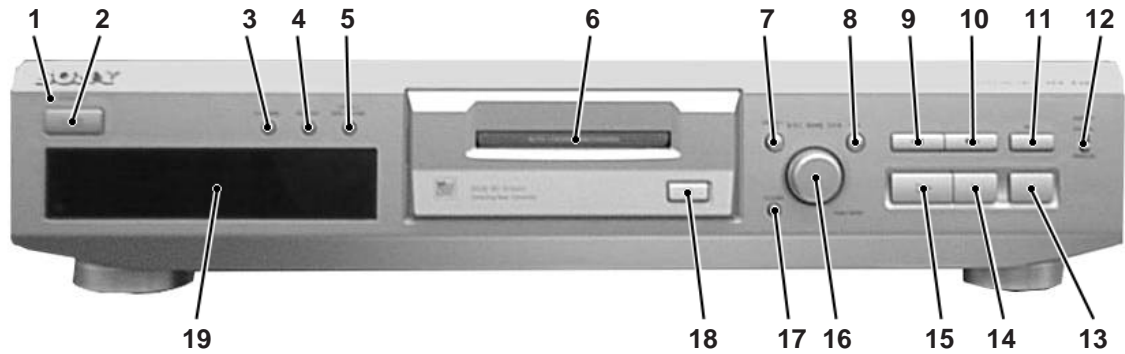

LOCATION OF PARTS AND CONTROLS

- 1 STANDBY indicator
- 2 I/⏻ (Power) button
- 3 PLAY MODE button
- 4 REPEAT button
- 5 LEVEL/DISPLAY/CHAR button
- 6 DISK compartment
- 7 MENU/NO button
- 8 YES button
- 9 ◀◀ button
- 10 ▶▶ button
- 11 ● REC (Recording) button
- 12 INPUT DIGITAL/ANALOG switch
- 13 ■ (stop) button
- 14 || (Pause) button
- 15 ▷ (Play) button
- 16 ◀◀ AMS ▶▶ PUSH ENTOR knob
- 17 CLEAR button
- 18 ☐ (Eject) button
- 19 DISPLAY window

- AMS is the abbreviation for Automatic Music Sensor.

SECTION 3 DISASSEMBLY

Note: Follow the disassembly procedure in the numerical order given.

3-1. CASE AND FRONT PANEL

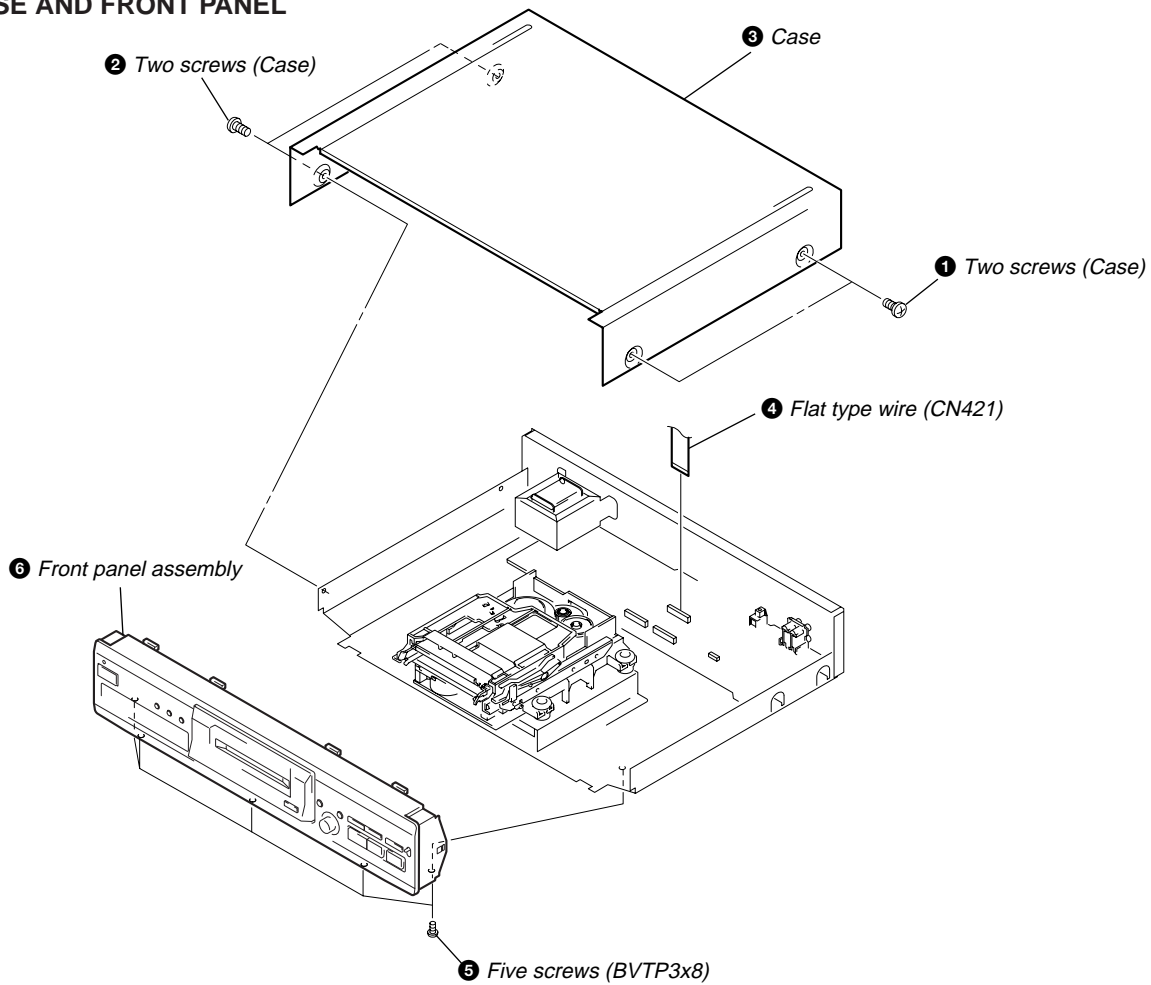

3-2. SLIDER (CAM)

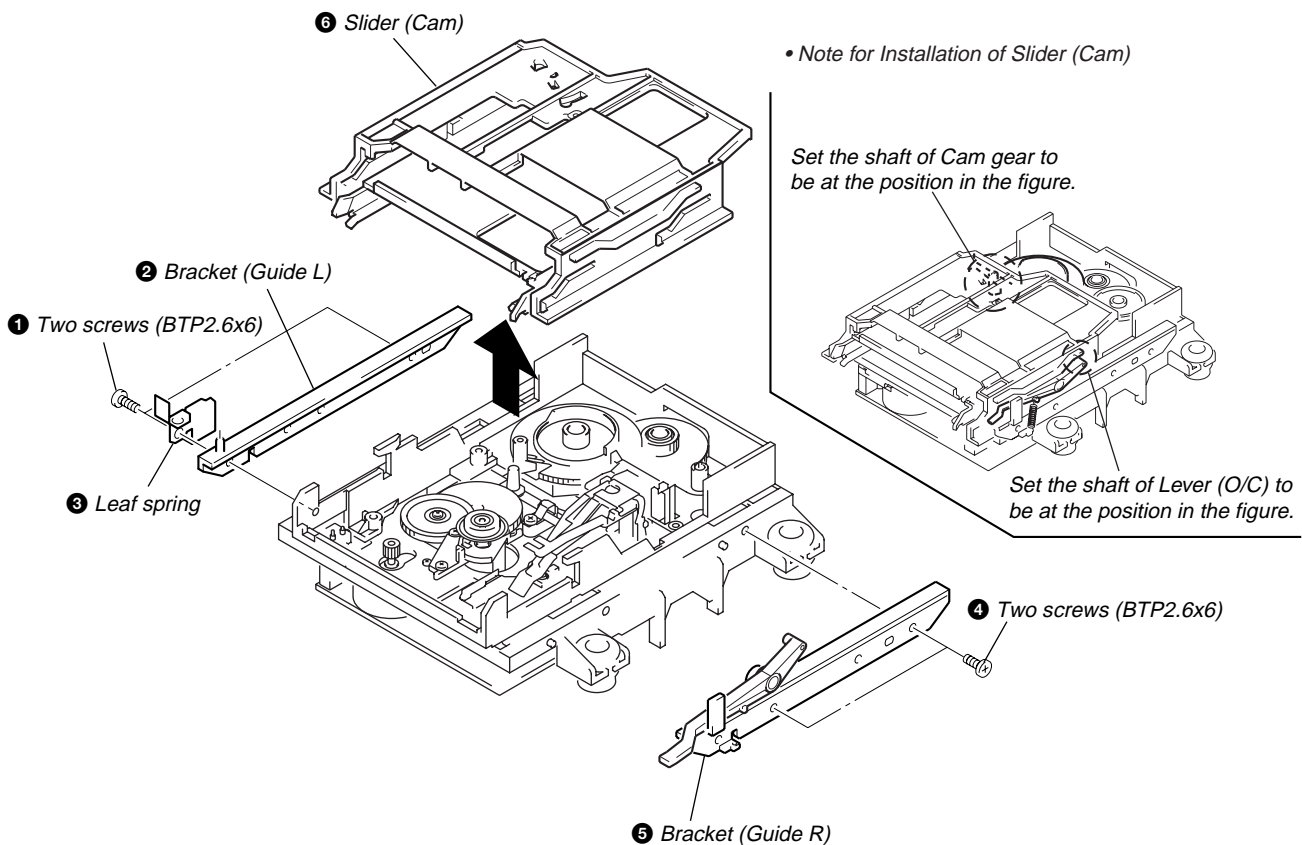

3-3. BASE UNIT (MBU-5A) AND BD BOARD

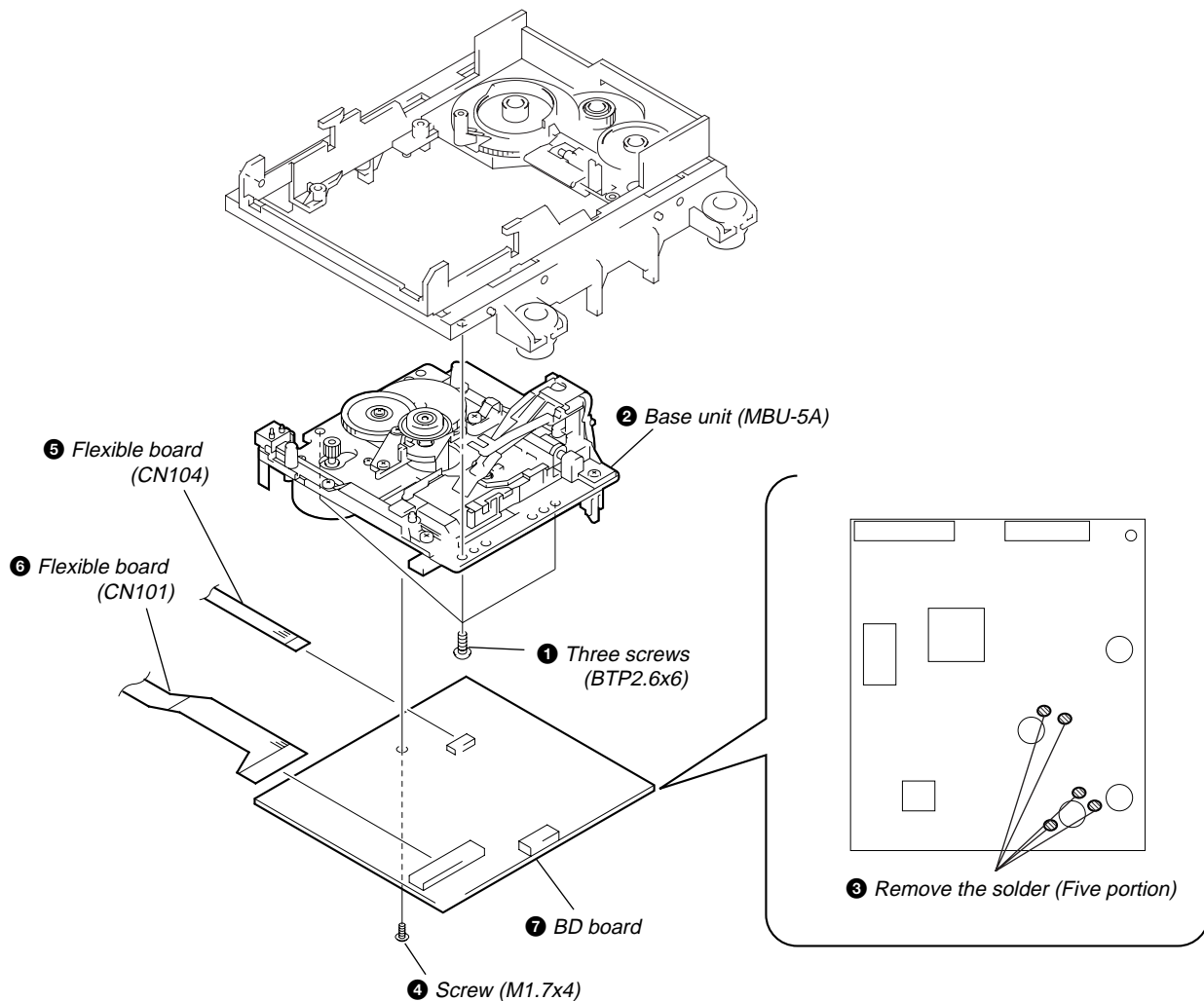

3-4. SW BOARD AND LOADING MOTOR (M103)

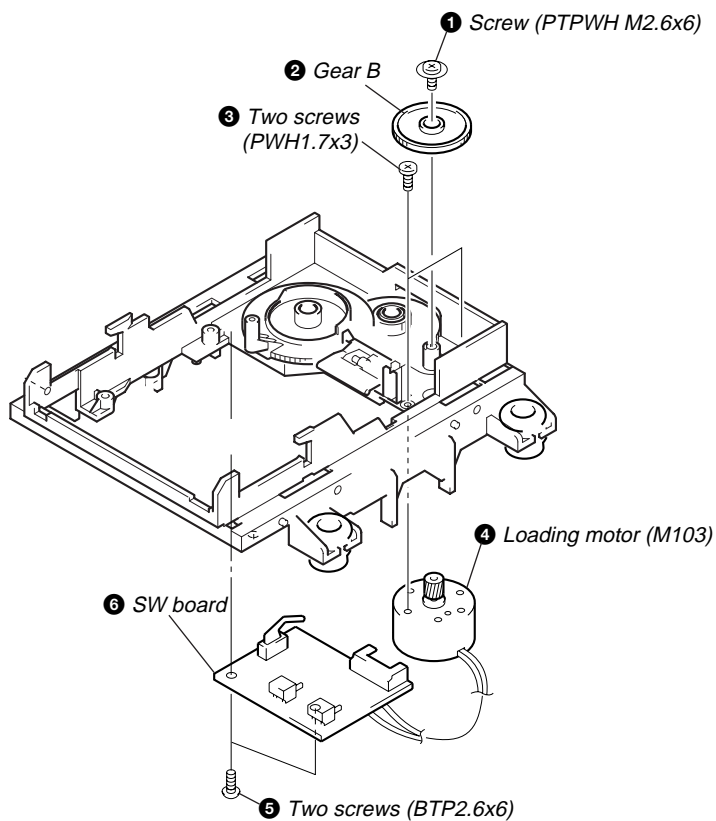

SECTION 4 TEST MODE

4-1. PRECAUTIONS FOR USE OF TEST MODE

- As loading related operations will be performed regardless of the test mode operations being performed, be sure to check that the disc is stopped before setting and removing it.
Even if the **EJECT** button is pressed while the disc is rotating during continuous playback, continuous recording, etc., the disc will not stop rotating.
Therefore, it will be ejected while rotating.
Be sure to press the **EJECT** button after pressing the **MENU/NO** button and the rotation of disc is stopped.

4-1-1. Recording laser emission mode and operating buttons

- Continuous recording mode (CREC MODE)
- Laser power check mode (LDPWR CHECK)
- Laser power adjustment mode (LDPWR ADJUST)
- Traverse (MO) check (EF MO CHECK)
- Traverse (MO) adjustment (EF MO ADJUST)
- When pressing the **REC** button.

4-2. SETTING THE TEST MODE

The following are two methods of entering the test mode.

Procedure 1: While pressing the **AMS** knob and **STOP** button, connect the power plug to an outlet, and release the **AMS** knob and **STOP** button.

When the test mode is set, “[Check]” will be displayed. Rotating the **AMS** knob switches between the following four groups;
...←→ Check ←→ Adjust ←→ Service ←→ Develop ←→ ...

Procedure 2: While pressing the **AMS** knob, connect the power plug to the outlet and release the **AMS** knob.

When the test mode is set, “TEMP CHECK” will be displayed. By setting the test mode using this method, only the “Check” group of method 1 can be executed.

4-3. EXITING THE TEST MODE

Press the **REPEAT** button. The disc is ejected when loaded, and “Standby” display blinks, and the STANDBY state is set.

4-4. BASIC OPERATIONS OF THE TEST MODE

All operations are performed using the **AMS** knob, **YES** button, and **MENU/NO** button.

The functions of these buttons are as follows.

Function name	Function
AMS knob	Changes parameters and modes
YES button	Proceeds onto the next step. Finalizes input.
MENU/NO button	Returns to previous step. Stops operations.

4-5. SELECTING THE TEST MODE

There are 24 types of test modes as shown below. The groups can be switched by rotating the [AMS] knob. After selecting the group to be used, press the [YES] button. After setting a certain group, rotating the [AMS] knob switches between these modes. Refer to “Group” in the table for details selected.

All items used for servicing can be treated using group S. So be carefully not to enter other groups by mistake.

Display	Contents	Mark	Group (*)
TEMP CHECK	Temperature compensation offset check		C S
LDPWR CHECK	Laser power check		C S
EF MO CHECK	Traverse (MO) check		C S
EF CD CHECK	Traverse (CD) check		C S
FBIAS CHECK	Focus bias check		C S
S curve CHECK	S letter check	(X)	C
VERIFY MODE	Non-volatile memory check	(X)	C
DETRK CHECK	Detrack check	(X)	C
TEMP ADJUST	Temperature compensation offset adjustment		A S
LDPWR ADJUST	Laser power adjustment		A S
EF MO ADJUST	Traverse (MO) adjustment		A S
EF CD ADJUST	Traverse (CD) adjustment		A S
FBIAS ADJUST	Focus bias adjustment		A S
EEP MODE	Non-volatile memory control	(X) (!)	D
Impossible	No function	(X)	D
ERR DP MODE	Error history display, clear		S
ADJ CLEAR	Initialization of non-volatile memory of adjustment value		A S
AG Set (MO)	Auto gain output level adjustment (MO)		A S
AG Set (CD)	Auto gain output level adjustment (CD)		A S
Iop Read	IOP data display		C S
Iop Write	IOP data write		A S
S40 @ @ . @ @	Microprocessing version display		C S
CPLAY MODE	Continuous play mode		C A S D
CREC MODE	Continuous recording mode		C A S D

Group (*)

C: Check A: Adjust
S: Service D: Develop

- For details of each adjustment mode, refer to “5. Electrical Adjustments”.
- For details of “ERR DP MODE”, refer to “Self-Diagnosis Function” on page 2.
- If a different mode has been selected by mistake, press the [MENU/NO] button to exit that mode.
- Modes with (X) in the Mark column are not used for servicing and therefore are not described in detail. If these modes are set accidentally, press the [MENU/NO] button to exit the mode immediately. Be especially careful not to set the modes with (!) as they will overwrite the non-volatile memory and reset it, and as a result, the unit will not operate normally.

4-5-1. Operating the Continuous Playback Mode

1. Entering the continuous playback mode

- ① Set the disc in the unit. (Whichever recordable discs or discs for playback only are available.)
- ② Rotate the [AMS] knob and display "CPLAY MODE".
- ③ Press the [YES] button to change the display to "CPLAY MID".
- ④ When access completes, the display changes to "C = [] AD = []".

Note : The numbers "[]" displayed show you error rates and ADER.

2. Changing the parts to be played back

- ① Press the [YES] button during continuous playback to change the display as below.

"CPLAY MID" → "CPLAY OUT" → "CPLAY IN" →



When pressed another time, the parts to be played back can be moved.

- ② When access completes, the display changes to "C = [] AD = []".

Note : The numbers "[]" displayed show you error rates and ADER.

3. Ending the continuous playback mode

- ① Press the [MENU/NO] button. The display will change to "CPLAY MODE".
- ② Press the [EJECT] button to remove the disc.

Note : The playback start addresses for IN, MID, and OUT are as follows.

IN 40h cluster
MID 300h cluster
OUT 700h cluster

4-5-2. Operating the Continuous Recording Mode (Use only when performing self-recording/palyback check.)

1. Entering the continuous recording mode

- ① Set a recordable disc in the unit.
- ② Rotate the [AMS] knob and display "CREC MODE".
- ③ Press the [YES] button to change the display to "CREC MID".
- ④ When access completes, the display changes to "CREC ([])" and [REC] lights up.

Note : The numbers "[]" displayed shows you the recording position addresses.

2. Changing the parts to be recorded

- ① When the [YES] button is pressed during continuous recording, the display changes as below.

"CPLAY MID" → "CPLAY OUT" → "CPLAY IN" →



When pressed another time, the parts to be recorded can be changed. [REC] goes off.

- ② When access completes, the display changes to "CREC ([])" and [REC] lights up.

Note : The numbers "[]" displayed shows you the recording position addresses.

3. Ending the continuous recording mode

- ① Press the [MENU/NO] button. The display changes to "CREC MODE" and [REC] goes off.
- ② Press the [EJECT] button to remove the disc.

Note 1 : The recording start addresses for IN, MID, and OUT are as follows.

IN 40h cluster
MID 300h cluster
OUT 700h cluster

Note 2 : The [MENU/NO] button can be used to stop recording anytime.

Note 3 : Do not perform continuous recording for long periods of time above 5 minutes.

Note 4 : During continuous recording, be careful not to apply vibration.

4-5-3. Non-Volatile Memory Mode (EEP MODE)

This mode reads and writes the contents of the non-volatile memory.

It is not used in servicing. If set accidentally, press the [MENU/NO] button immediately to exit it.

4-6. FUNCTIONS OF OTHER BUTTONS

Function	Contents
▷	Sets continuous playback when pressed in the STOP state. When pressed during continuous playback, the tracking servo turns ON/OFF.
■	Stops continuous playback and continuous recording.
▶▶	The sled moves to the outer circumference only when this is pressed.
◀◀	The sled moves to the inner circumference only when this is pressed.
PLAY MODE → LEVEL/DISPLAY/CHAR (*)	Switches between the pit and groove modes when pressed.
PLAY MODE → PLAY MODE (*)	Switches the spindle servo mode (CLV S ↔ CLV A).
LEVEL/DISPLAY/CHAR	Switches the displayed contents each time the button is pressed
⊞	Ejects the disc
REPEAT	Exits the test mode

(*)When displayed as “PLAY MODE→PLAY MODE”, it means to press the **PLAY MODE** button, and then press it again. When pressed the first time, the fluorescent display tube displays “PROGRAM”.

4-7. TEST MODE DISPLAYS

Each time the **LEVEL/DISPLAY/CHAR** button is pressed, the display changes in the following order.

1. Mode display

Displays “TEMP ADJUST”, “CPLAYMODE”, etc.

2. Error rate display

Displays the error rate in the following way.

C1 = □□□□ AD = □□

C1 = Indicates the C1 error.

AD = Indicates ADER.

3. Address display

The address is displayed as follows. (MO:recordable disc, CD:playback only disc)

If the **LEVEL/DISPLAY/CHAR** button is pressed after pressing the **PROGRAM** button, the display switches from groove to pit or vice versa.

h = □□□□ s = □□□□ (MO pit and CD)

h = □□□□ a = □□□□ (MO groove)

h = Indicates the header address.

s = Indicates the SUBQ address.

a = Indicates the ADIP address.

Note: “-” is displayed when servo is not imposed.

4. Auto gain display (Not used in servicing)

The auto gain is displayed as follows.

AG = □□/□□ [□□]

5. Detrack check display (Not used in servicing)

The detrack is displayed as follows.

ADR = □□□□□□

6. IVR display (Not used in servicing)

The IVR is displayed as follows.

[□□][□□][□□]

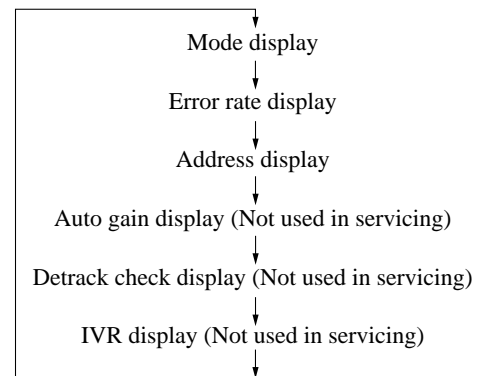

MEANINGS OF OTHER DISPLAYS

Display	Contents	
	When Lit	When Off
▷	During continuous playback (CLV: ON)	STOP (CLV: OFF)
	Tracking servo OFF	Tracking servo ON
REC	Recording mode ON	Recording mode OFF
SYNC	CLV low speed mode	CLV normal mode
L.SYNC	ABCD adjustment completed	
OVER	Tracking offset cancel ON	Tracking offset cancel OFF
B	Tracking auto gain OK	
A-	Focus auto gain OK	
TRACK	Pit	Groove
DISC	High reflection	Low reflection
SLEEP	CLV S	CLV A
MONO	CLV LOCK	CLV UNLOCK
PROGRAM	When the PLAY MODE button is pressed	

SECTION 5 ELECTRICAL ADJUSTMENTS

5-1. PARTS REPLACEMENT AND ADJUSTMENT

- Check and adjust the MDM and MBU as follows.
The procedure changes according to the part replaced

- Abbreviation
OP : Optical pick-up
OWH: Overwrite head

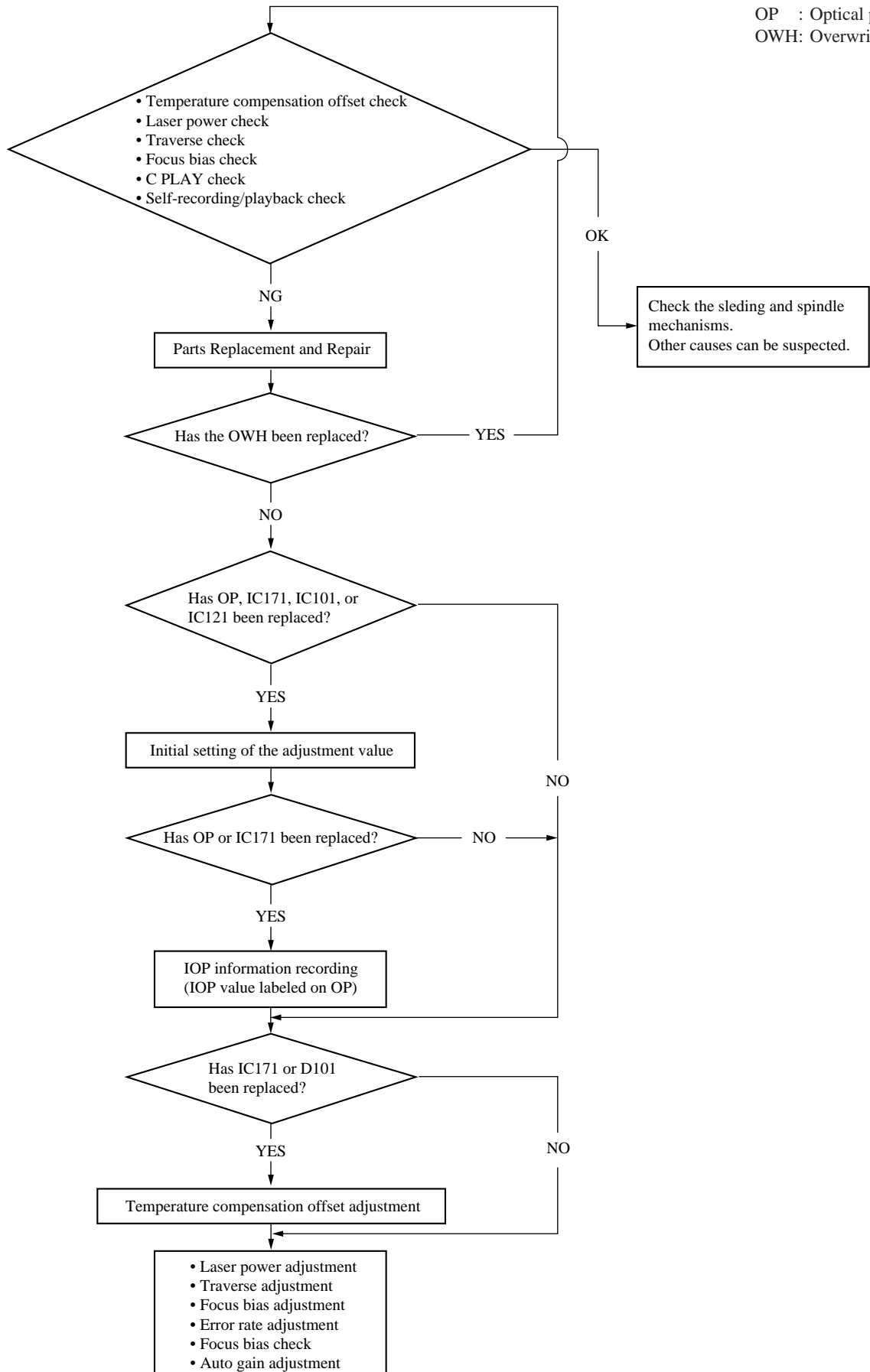

5-2. PRECAUTIONS FOR CHECKING LASER DIODE EMISSION

To check the emission of the laser diode during adjustments, never view directly from the top as this may lose your eye-sight.

5-3. PRECAUTIONS FOR USE OF OPTICAL PICK-UP (KMS-260A)

As the laser diode in the optical pick-up is easily damaged by static electricity, solder the laser tap of the flexible board when using it. Before disconnecting the connector, desolder first. Before connecting the connector, be careful not to remove the solder. Also take adequate measures to prevent damage by static electricity. Handle the flexible board with care as it breaks easily.

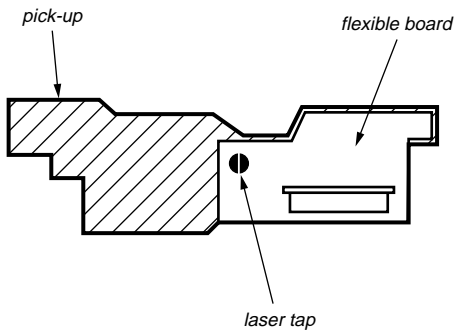

Optical pick-up flexible board

5-4. PRECAUTIONS FOR ADJUSTMENTS

1) When replacing the following parts, perform the adjustments and checks with ○ in the order shown in the following table.

	Optical Pick-up	BD Board			
		IC171	D101	IC101, IC121	IC192
1. Initial setting of adjustment value	○	○	×	○	×
2. Recording of IOP information (Value written in the pick-up)	○	○	×	×	×
3. Temperature compensation offset adjustment	×	○	○	×	×
4. Laser power adjustment	○	○	×	○	○
5. Traverse adjustment	○	○	×	○	×
6. Focus bias adjustment	○	○	×	○	×
7. Error rate check	○	○	×	○	×
8. Auto gain output level adjustment	○	○	×	○	×

- 2) Set the test mode when performing adjustments.
After completing the adjustments, exit the test mode.
Perform the adjustments and checks in "group S" of the test mode.
- 3) Perform the adjustments to be needed in the order shown.

- 4) Use the following tools and measuring devices.
 - Check Disc (MD) TDYS-1 (Parts No. 4-963-646-01)
 - Test Disk (MDW-74/AU-1) (Parts No. 8-892-341-41)
 - Laser power meter LPM-8001 (Parts No. J-2501-046-A)
or
 - MD Laser power meter 8010S (Parts No. J-2501-145-A)
 - Oscilloscope (Measure after performing CAL of prove.)
 - Digital voltmeter
 - Thermometer
 - Jig for checking BD board waveform (Parts No. : J-2501-149-A)
- 5) When observing several signals on the oscilloscope, etc., make sure that VC and ground do not connect inside the oscilloscope.
(VC and ground will become short-circuited.)
- 6) Using the above jig enables the waveform to be checked without the need to solder.
(Refer to Servicing Note on page 6.)
- 7) As the disc used will affect the adjustment results, make sure that no dusts nor fingerprints are attached to it.

5-5. CREATING CONTINUOUSLY RECORDED DISC

* This disc is used in focus bias adjustment and error rate check.

The following describes how to create a continuous recording disc.

1. Insert a disc (blank disc) commercially available.
2. Rotate the **[AMS]** knob and display "CREC MODE".
3. Press the **[YES]** button again to display "CREC MID".
Display "CREC (0300)" and start to recording.
4. Complete recording within 5 minutes.
5. Press the **[MENU/NO]** button and stop recording .
6. Press the **[EJECT]** button and remove the disc.

The above has been how to create a continuous recorded data for the focus bias adjustment and error rate check.

Note :

- Be careful not to apply vibration during continuous recording.

5-6. CHECKS PRIOR TO REPAIRS

These checks are performed before replacing parts according to “approximate specifications” to determine the faulty locations. For details, refer to “Checks Prior to Parts Replacement and Adjustments” (See page 8).

5-6-1. Temperature Compensation Offset Check

When performing adjustments, set the internal temperature and room temperature to 22 to 28°C.

Checking Procedure:

1. Rotate the **[AMS]** knob to display “TEMP CHECK”.
2. Press the **[YES]** button.
3. “T=@@ (##) [OK]” should be displayed. If “T=@@ (##) [NG]” is displayed, it means that the results are bad.
(@@ indicates the current value set, and ## indicates the value written in the non-volatile memory.)

5-6-2. Laser Power Check

Before checking, check the IOP value of the optical pick-up.
(Refer to 5-8. Recording and Displaying IOP Information.)

Connection :

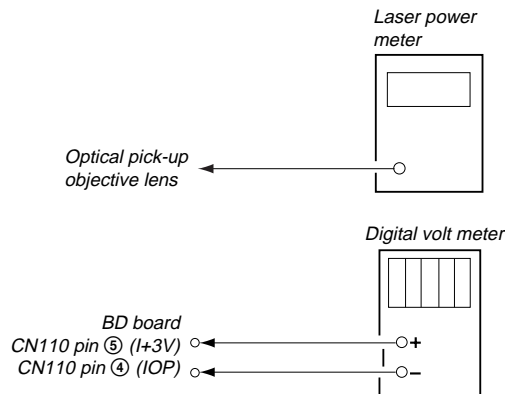

Checking Procedure:

1. Set the laser power meter on the objective lens of the optical pick-up. (When it cannot be set properly, press the **[◀▶]** button or **[▶▶]** button to move the optical pick-up.)
Connect the digital volt meter to CN110 pin ⑤ (I+3V) and CN110 pin ④ (IOP).
2. Then, rotate the **[AMS]** knob and display “LDPWR CHECK”.
3. Press the **[YES]** button once and display “0.9 mW *** \$ []”.
Check that the reading of the laser power meter become 0.84 to 0.92 mW. (***) means IOP value)
4. Press the **[YES]** button once more and display “7.0 mW *** \$ []”.
Check that the reading the laser power meter and digital volt meter satisfy the specified value.

Specified Value :

Laser power meter reading : 7.0 ± 0.2 mW

Digital voltmeter reading : Optical pick-up displayed value ± 10%

(Optical pick-up label)

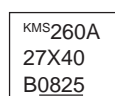

(For details of the method for checking this value, refer to “5-8. Recording and Displaying IOP Information.”)

$lop = 82.5 \text{ mA}$ in this case
 $lop \text{ (mA)} = \text{Digital voltmeter reading (mV)} / 1 \text{ (}\Omega\text{)}$

5. Press the **[MENU/NO]** button and display “LDPWR CHECK” and stop the laser emission.
(The **[MENU/NO]** button is effective at all times to stop the laser emission.)

Note 1: After step 4, each time the **[YES]** button is pressed, the display will be switched between “0.7 mW *** \$ []”, “6.2 mW *** \$ []”, and “Wp ホセイ *** \$ []”. Nothing needs to be performed here.

5-6-3. Traverse Check

Connection :

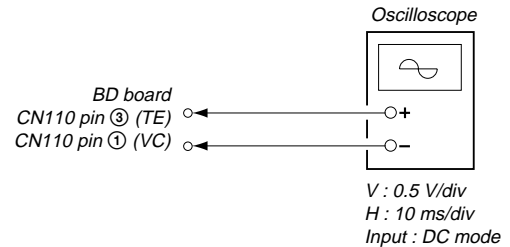

Checking Procedure:

1. Connect an oscilloscope to CN110 pin ③ (TE) and CN110 pin ① (VC) of the BD board.
2. Load a disc (any available on the market). (Refer to Note 1.)
3. Press the **[▶▶]** button and move the optical pick-up outside the pit.
4. Rotate the **[AMS]** knob and display “EF MO CHECK”.
5. Press the **[YES]** button and display “EFB = [] MO-R”.
(Laser power READ power/Focus servo ON/tracking servo OFF/spindle (S) servo ON)
6. Observe the waveform of the oscilloscope, and check that the specified value is satisfied. Do not rotate the **[AMS]** knob.
(Read power traverse checking)

(Traverse Waveform)

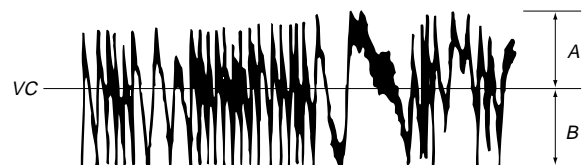

Specified value : Below 10% offset value

$$\text{Offset value (\%)} = \frac{A - B}{2(A + B)} \times 100$$

7. Press the **[YES]** button and display “EFB = [] MO-W”.
8. Observe the waveform of the oscilloscope, and check that the specified value is satisfied. Do not rotate the **[AMS]** knob.
(Write power traverse checking)

(Traverse Waveform)

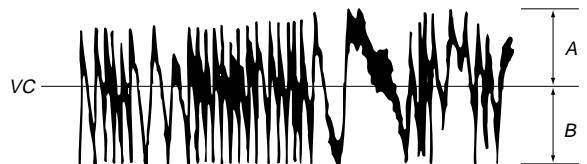

Specified value : Below 10% offset value

$$\text{Offset value (\%)} = \frac{A - B}{2(A + B)} \times 100$$

9. Press the **[YES]** button display “EFB = [] MO-P”.
Then, the optical pick-up moves to the pit area automatically and servo is imposed.

10. Observe the waveform of the oscilloscope, and check that the specified value is satisfied. Do not rotate the **[AMS]** knob.

(Traverse Waveform)

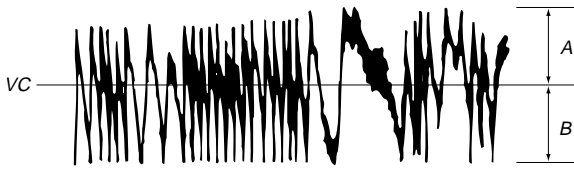

Specified value : Below 10% offset value

$$\text{Offset value (\%)} = \frac{|A - B|}{2(A + B)} \times 100$$

11. Press the **[YES]** button display "EF MO CHECK"
The disc stops rotating automatically.
12. Press the **[⏏]** button and remove the disc.
13. Load the check disc (MD) TDYS-1.
14. Rotate the **[AMS]** knob and display "EF CD CHECK" (C04).
15. Press the **[YES]** button and display "EFB = [] CD". Servo is imposed automatically.
16. Observe the waveform of the oscilloscope, and check that the specified value is satisfied. Do not rotate the **[AMS]** knob.

(Traverse Waveform)

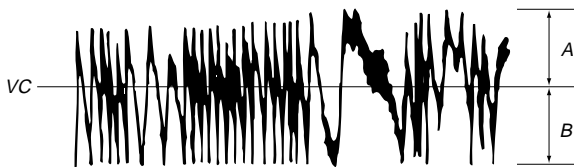

Specified value : Below 10% offset value

$$\text{Offset value (\%)} = \frac{|A - B|}{2(A + B)} \times 100$$

17. Press the **[YES]** button and display "EF CD CHECK".
18. Press the **[⏏]** button and remove the check disc (MD) TDYS-1.

Note 1 : MO reading data will be erased during if a recorded disc is used in this adjustment.

Note 2 : If the traverse waveform is not clear, connect the oscilloscope as shown in the following figure so that it can be seen more clearly.

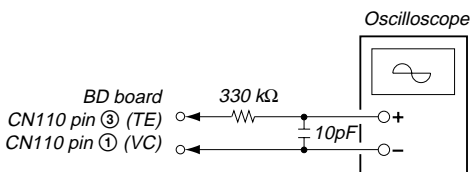

5-6-4. Focus Bias Check

Change the focus bias and check the focus tolerance amount.

Checking Procedure :

1. Load a test disk (MDW-74/AU-1).
2. Rotate the **[AMS]** knob and display "CPLAY MODE".
3. Press the **[YES]** button twice and display "CPLAY MID".
4. Press the **[MENU/NO]** button when "C = [] AD = []" is displayed.
5. Rotate the **[AMS]** knob and display "FBIAS CHECK".
6. Press the **[YES]** button and display "[]/[] c = []".
The first four digits indicate the C1 error rate, the two digits after [/] indicate ADER, and the 2 digits after [c =] indicate the focus bias value.
Check that the C1 error is below 220 and ADER is below 2.
7. Press the **[YES]** button and display "[]/[] b = []".
Check that the C1 error is below 220 and ADER is below 2.
8. Press the **[YES]** button and display "[]/[] a = []".
Check that the C1 error is below 220 and ADER is below 2.
9. Press the **[MENU/NO]** button, next press the **[⏏]** button, and remove the test disc.

5-6-5. C PLAY Checking

MO Error Rate Check

Checking Procedure :

1. Load a test disk (MDW-74/AU-1).
2. Rotate the **[AMS]** knob and display "CPLAY MODE".
3. Press the **[YES]** button and display "CPLAY MID".
4. The display changes to "C1 = [] AD = []".
5. If the C1 error rate is below 80, check that ADER is below 2.
6. Press the **[MENU/NO]** button, stop playback, press the **[⏏]** button, and test disc.

CD Error Rate Check

Checking Procedure :

1. Load a check disc (MD) TDYS-1.
2. Rotate the **[AMS]** knob and display "CPLAY MODE".
3. Press the **[YES]** button twice and display "CPLAY MID".
4. The display changes to "C1 = [] AD = []".
5. Check that the C1 error rate is below 50.
6. Press the **[MENU/NO]** button, stop playback, press the **[⏏]** button, and the test disc.

5-6-6. Self-Recording/playback Check

Prepare a continuous recording disc using the unit to be repaired and check the error rate.

Checking Procedure :

1. Insert a recordable disc (blank disc) into the unit.
2. Rotate the **[AMS]** knob to display "CREC MODE".
3. Press the **[YES]** button to display the "CREC MID".
4. When recording starts, "**REC**" is displayed, this becomes "CREC (@@@@)" (@@@@ is the address), and recording starts.
5. About 1 minute later, press the **[MENU/NO]** button to stop continuous recording.
6. Rotate the **[AMS]** knob to display "C PLAY MODE".
7. Press the **[YES]** button to display "C PLAY MID".
8. "C1 = [] AD = []" will be displayed.
9. Check that the C1 error becomes below 80 and the AD error below 2.
10. Press the **[MENU/NO]** button to stop playback, and press the **[⏏]** button and remove the disc.

5-7. INITIAL SETTING OF ADJUSTMENT VALUE

Note:

Mode which sets the adjustment results recorded in the non-volatile memory to the initial setting value. However the results of the temperature compensation offset adjustment will not change to the initial setting value.

If initial setting is performed, perform all adjustments again excluding the temperature compensation offset adjustment.

For details of the initial setting, refer to "5-4. Precautions on Adjustments" and execute the initial setting before the adjustment as required.

Setting Procedure :

1. Rotate the [AMS] knob to display "ADJ CLEAR".
2. Press the [YES] button. "Complete!" will be displayed momentarily and initial setting will be executed, after which "ADJ CLEAR" will be displayed.

5-8. RECORDING AND DISPLAYING THE IOP INFORMATION

The IOP data can be recorded in the non-volatile memory. The IOP value on the label of the optical pickup and the IOP value after the adjustment will be recorded. Recording these data eliminates the need to read the label on the optical pick-up.

Recording Procedure :

1. While pressing the [AMS] knob and [] button, connect the power plug to the outlet, and release the [AMS] knob and [] button.
2. Rotate the [AMS] knob to display "[Service]", and press the [YES] button.
3. Rotate the [AMS] knob to display "Top.Write", and press the [YES] button.
4. The display becomes Ref=@@.@ (@ is an arbitrary number) and the numbers which can be changed will blink.
5. Input the IOP value written on the optical pick-up.
To select the number : Rotate the [AMS] knob.
To select the digit : Press the [AMS] knob
6. When the [YES] button is pressed, the display becomes "Measu=@@.@." (@ is an arbitrary number).
7. As the adjustment results are recorded for the 6 value. Leave it as it is and press the [YES] button.
8. "Complete!" will be displayed momentarily. The value will be recorded in the non-volatile memory and the display will become "Iop Write".

Display Procedure :

1. Rotate the [AMS] knob to display "Iop.Read".
2. "@@.@/##.#" is displayed and the recorded contents are displayed.
@@.@ indicates the Iop value labeled on the pick-up.
##.# indicates the Iop value after adjustment
3. To end, press the [AMS] button or [MENU/NO] button to display "Iop Read".

5-9. TEMPERATURE COMPENSATION OFFSET ADJUSTMENT

Save the temperature data at that time in the non-volatile memory as 25 °C reference data.

Note :

1. Usually, do not perform this adjustment.
2. Perform this adjustment in an ambient temperature of 22 °C to 28 °C. Perform it immediately after the power is turned on when the internal temperature of the unit is the same as the ambient temperature of 22 °C to 28 °C.
3. When D101 has been replaced, perform this adjustment after the temperature of this part has become the ambient temperature.

Adjusting Procedure :

1. Rotate the [AMS] knob and display "TEMP ADJUST".
2. Press the [YES] button and select the "TEMP ADJUST" mode.
3. "TEMP = [] [OK]" and the current temperature data will be displayed.
4. To save the data, press the [YES] button.
When not saving the data, press the [MENU/NO] button.
5. When the [YES] button is pressed, "TEMP = [] SAVE" will be displayed and turned back to "TEMP ADJUST" display then. When the [MENU/NO] button is pressed, "TEMP ADJUST" will be displayed immediately.

Specified Value :

The "TEMP = []" should be within "E0 - EF", "F0 - FF", "00 - 0F", "10 - 1F" and "20 - 2F".

5-10. LASER POWER ADJUSTMENT

Check the IOP value of the optical pick-up before adjustments. (Refer to 5-8. Recording and Displaying IOP Information.)

Connection :

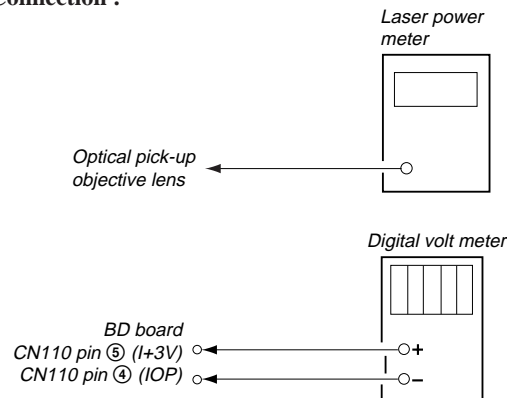

Adjusting Procedure :

1. Set the laser power meter on the objective lens of the optical pick-up. (When it cannot be set properly, press the [◀] button or [▶] button to move the optical pick-up.)
Connect the digital volt meter to CN110 pin 5 (I+3V) and CN110 pin 4 (IOP).
2. Rotate the [AMS] knob and display "LDPWR ADJUST". (Laser power : For adjustment)
3. Press the [YES] button once and display "LD 0.9 mW \$ []".
4. Rotate the [AMS] knob so that the reading of the laser power meter becomes 0.85 to 0.91 mW. Press the [YES] button after setting the range knob of the laser power meter, and save the adjustment results. ("LD SAVE \$ []" will be displayed for a moment.)
5. Then "LD 7.0 mW \$ []" will be displayed.
6. Rotate the [AMS] knob so that the reading of the laser power meter becomes 6.9 to 7.1 mW, press the [YES] button and save it.

Note : Do not perform the emission with 7.0 mW more than 15 seconds continuously.

7. Then, rotate the **AMS** knob and display "LDPWR CHECK".
8. Press the **YES** button once and display "0.9 mW *** \$ []". Check that the reading of the laser power meter become 0.85 to 0.91 mW. (***) means IOP value)
9. Press the **YES** button once more and display "7.0 mW *** \$ []". Check that the reading of the laser power meter and digital volt meter satisfy the specified value.
Note down the digital voltmeter reading value.

Specified Value :

Laser power meter reading : 7.0 ± 0.1 mW

Digital voltmeter reading : Optical pick-up displayed value $\pm 10\%$

(Optical pick-up label)

KMS260A
27X40
B0825

(For details of the method for checking this value, refer to "5-8. Recording and Displaying IOP Information".)

$I_{op} = 82.5$ mA in this case

$I_{op} \text{ (mA)} = \text{Digital voltmeter reading (mV)} / 1 \text{ (}\Omega\text{)}$

10. Press the **MENU/NO** button and display "LDPWR CHECK" and stop the laser emission.
(The **MENU/NO** button is effective at all times to stop the laser emission.)
11. Rotate the **AMS** knob to display "Iop.Write".
12. Press the **YES** button. When the display becomes Ref=@@.@ (@ is an arbitrary number), press the **YES** button to display "Measu=@@.@" (@ is an arbitrary number).
13. The numbers which can be changed will blink. Input the Iop value noted down at step 9.
To select the number : Rotate the **AMS** knob.
To select the digit : Press the **AMS** knob
14. When the **YES** button is pressed, "Complete!" will be displayed momentarily. The value will be recorded in the non-volatile memory and the display will become "Iop Write".

Note 1: After step 4, each time the **YES** button is pressed, the display will be switched between "0.7 mW *** \$ []", "6.2 mW *** \$ []", and "Wp ホセイ *** \$ []". Nothing needs to be performed here.

5-11. TRAVERSE ADJUSTMENT

Connection :

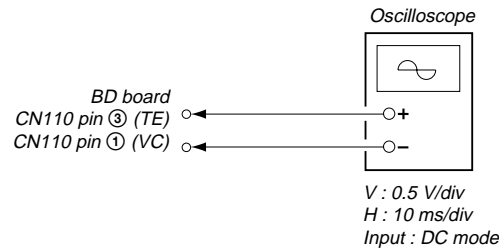

Adjusting Procedure :

1. Connect an oscilloscope to CN110 pin ③ (TE) and CN110 pin ① (VC) of the BD board.
2. Load a disc (any available on the market). (Refer to Note 1.)
3. Press the **▶▶** button and move the optical pick-up outside the pit.
4. Rotate the **AMS** knob and display "EF MO ADJUST".
5. Press the **YES** button and display "EFB = [] MO-R".
(Laser power READ power/Focus servo ON/tracking servo OFF/spindle (S) servo ON)
6. Rotate the **AMS** knob so that the waveform of the oscilloscope becomes the specified value.
(When the **AMS** knob is rotated, the [] of "EFB = []" changes and the waveform changes.) In this adjustment, waveform varies at intervals of approx. 2%. Adjust the waveform so that the specified value is satisfied as much as possible.
(Read power traverse adjustment)

(Traverse Waveform)

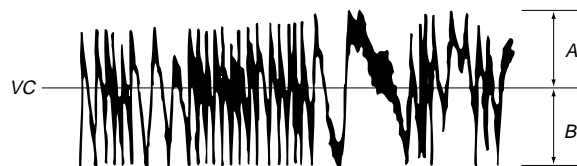

Specification A = B

7. Press the **YES** button and save the result of adjustment to the non-volatile memory ("EFB = [] SAVE" will be displayed for a moment. Then "EFB = [] MO-W" will be displayed).
8. Rotate the **AMS** knob so that the waveform of the oscilloscope becomes the specified value.
(When the **AMS** knob is rotated, the [] of "EFB = []" changes and the waveform changes.) In this adjustment, waveform varies at intervals of approx. 2%. Adjust the waveform so that the specified value is satisfied as much as possible.
(Write power traverse adjustment)

(Traverse Waveform)

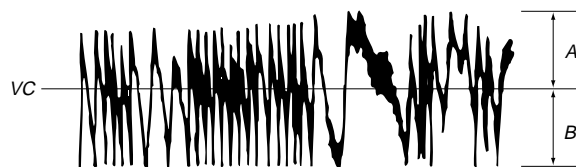

Specification A = B

9. Press the **YES** button, and save the adjustment results in the non-volatile memory. ("EFB = [] SAVE" will be displayed for a moment.)
10. "EFB = [] MO-P". will be displayed.
The optical pick-up moves to the pit area automatically and servo is imposed.

- Rotate the **[AMS]** knob until the waveform of the oscilloscope moves closer to the specified value.
In this adjustment, waveform varies at intervals of approx. 2%. Adjust the waveform so that the specified value is satisfied as much as possible.

(Traverse Waveform)

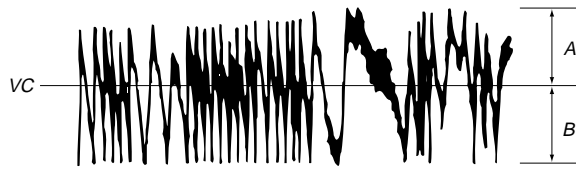

Specification $A = B$

- Press the **[YES]** button, and save the adjustment results in the non-volatile memory. ("EFB = **[]** SAVE" will be displayed for a moment.)
Next "EF MO ADJUST" is displayed. The disc stops rotating automatically.
- Press the **[]** button and remove the disc.
- Load the check disc (MD) TDYS-1.
- Rotate **[AMS]** knob and display "EF CD ADJUST".
- Press the **[YES]** button and display "EFB = **[]** CD". Servo is imposed automatically.
- Rotate the **[AMS]** knob so that the waveform of the oscilloscope moves closer to the specified value.
In this adjustment, waveform varies at intervals of approx. 2%. Adjust the waveform so that the specified value is satisfied as much as possible.

(Traverse Waveform)

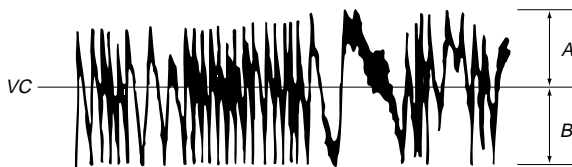

Specification $A = B$

- Press the **[YES]** button, display "EFB = **[]** SAVE" for a moment and save the adjustment results in the non-volatile memory. Next "EF CD ADJUST" will be displayed.
- Press the **[]** button and remove the check disc (MD) TDYS-1.

Note 1 : MO reading data will be erased during if a recorded disc is used in this adjustment.

Note 2 : If the traverse waveform is not clear, connect the oscilloscope as shown in the following figure so that it can be seen more clearly.

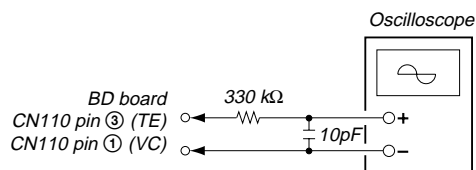

5-12. FOCUS BIAS ADJUSTMENT

Adjusting Procedure :

- Load a test disk (MDW-74/AU-1).
- Rotate the **[AMS]** knob and display "CPLAY MODE".
- Press the **[YES]** button and display "CPLAY MID".
- Press the **[MENU/NO]** button when "C1 = **[]** AD = **[]**" is displayed.
- Rotate the **[AMS]** knob and display "FBIAS ADJUST".
- Press the **[YES]** button and display "**[]** a = **[]**".
The first four digits indicate the C1 error rate, the two digits after [/] indicate ADER, and the 2 digits after [a =] indicate the focus bias value.
- Rotate the **[AMS]** knob in the clockwise direction and find the focus bias value at which the C1 error rate becomes 220 (Refer to Note 2).
- Press the **[YES]** button and display "**[]** b = **[]**".
- Rotate the **[AMS]** knob in the counterclockwise direction and find the focus bias value at which the C1 error rate becomes 220.
- Press the **[YES]** button and display "**[]** c = **[]**".
- Check that the C1 error rate is below 50 and ADER is 00. Then press the **[YES]** button.
- If the "**[]**" in "**[]** - **[]** - **[]**" is above 20, press the **[YES]** button.
If below 20, press the **[MENU/NO]** button and repeat the adjustment from step 2.
- Press the **[]** button to remove the test disc.

Note 1 : The relation between the C1 error and focus bias is as shown in the following figure. Find points a and b in the following figure using the above adjustment. The focal point position C is automatically calculated from points a and b.

Note 2 : As the C1 error rate changes, perform the adjustment using the average value.

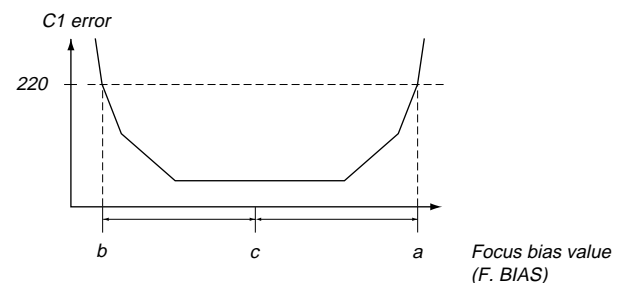

5-13. ERROR RATE CHECK

5-13-1. CD Error Rate Check

Checking Procedure :

1. Load a check disc (MD) TDYS-1.
2. Rotate the [AMS] knob and display "CPLAY MODE".
3. Press the [YES] button twice and display "CPLAY MID".
4. The display changes to "C1 = [] AD = []".
5. Check that the C1 error rate is below 20.
6. Press the [MENU/NO] button, stop playback, press the [] button, and remove the test disc.

5-13-2. MO Error Rate Check

Checking Procedure :

1. Load a test disc (MDW-74/AU-1).
2. Rotate the [AMS] knob and display "CPLAY MODE".
3. Press the [YES] button and display "CPLAY MID".
4. The display changes to "C1 = [] AD = []".
5. If the C1 error rate is below 50, check that ADER is 00.
6. Press the [MENU/NO] button, stop playback, press the [] button, and remove the test disc.

5-14. FOCUS BIAS CHECK

Change the focus bias and check the focus tolerance amount.

Checking Procedure :

1. Load a test disc (MDW-74/AU-1).
2. Rotate the [AMS] knob and display "CPLAY MODE".
3. Press the [YES] button twice and display "CPLAY MID".
4. Press the [MENU/NO] button when "C1 = [] AD = []" is displayed.
5. Rotate the [AMS] knob and display "FBIAS CHECK".
6. Press the [YES] button and display "[]/[] c = []".
The first four digits indicate the C1 error rate, the two digits after [/] indicate ADER, and the 2 digits after [c =] indicate the focus bias value.
Check that the C1 error is below 50 and ADER is below 2.
7. Press the [YES] button and display "[]/[] b = []".
Check that the C1 error is below 220 and ADER is below 2.
8. Press the [YES] button and display "[]/[] a = []".
Check that the C1 error is below 220 and ADER is below 2.
9. Press the [MENU/NO] button, next press the [] button, and remove the continuously recorded disc.

Note 1 : If the C1 error and ADER are above other than the specified value at points a (step 8. in the above) or b (step 7. in the above), the focus bias adjustment may not have been carried out properly. Adjust perform the beginning again.

5-15. AUTO GAIN CONTROL OUTPUT LEVEL ADJUSTMENT

Be sure to perform this adjustment when the pickup is replaced. If the adjustment results becomes "Adjust NG!", the pickup may be faulty or the servo system circuits may be abnormal.

5-15-1. CD Auto Gain Control Output Level Adjustment

Adjusting Procedure :

1. Insert the check disc (MD) TDYS-1.
2. Rotate the [AMS] knob to display "AG Set (CD)".
3. When the [YES] button is pressed, the adjustment will be performed automatically.
"Complete!!" will then be displayed momentarily when the value is recorded in the non-volatile memory, after which the display changes to "AG Set (CD)".
4. Press the [] button to remove the disc.

5-15-2. MO Auto Gain Control Output Level Adjustment

Adjusting Procedure :

1. Insert the reference disc (MDW-74/AU-1) for recording.
2. Rotate the [AMS] knob to display "AG Set (MO)".
3. When the [YES] button is pressed, the adjustment will be performed automatically.
"Complete!!" will then be displayed momentarily when the value is recorded in the non-volatile memory, after which the display changes to "AG Set (MO)".
4. Press the [] button to remove the disc.

5-15. ADJUSTING POINTS AND CONNECTING POINTS

[BD BOARD] (SIDE A)

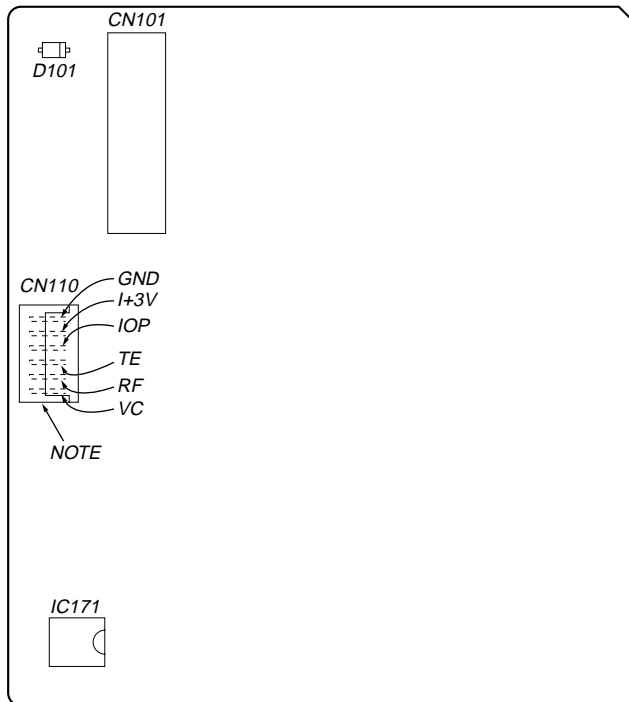

[BD BOARD] (SIDE B)

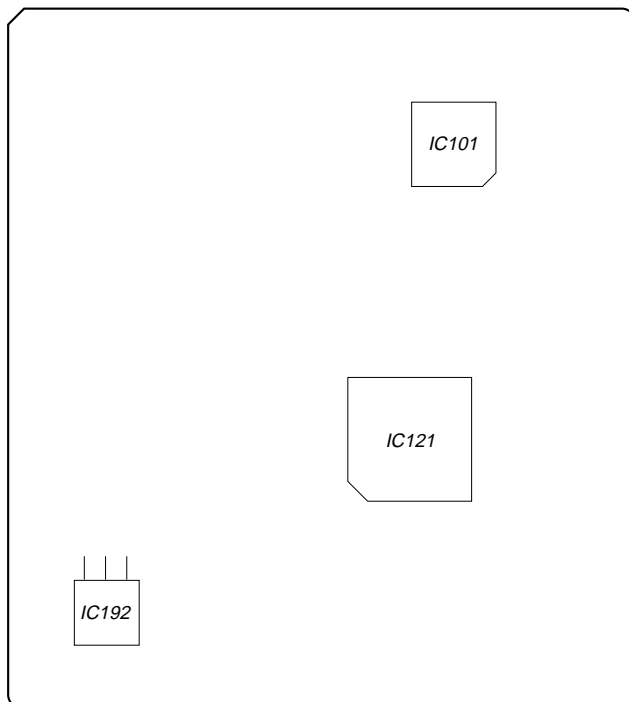

NOTE: It is useful to use the jig. for checking the waveform. (Refer to Servicing Note on page 6.)

SECTION 6 DIAGRAMS

6-1. CIRCUIT BOARDS LOCATION

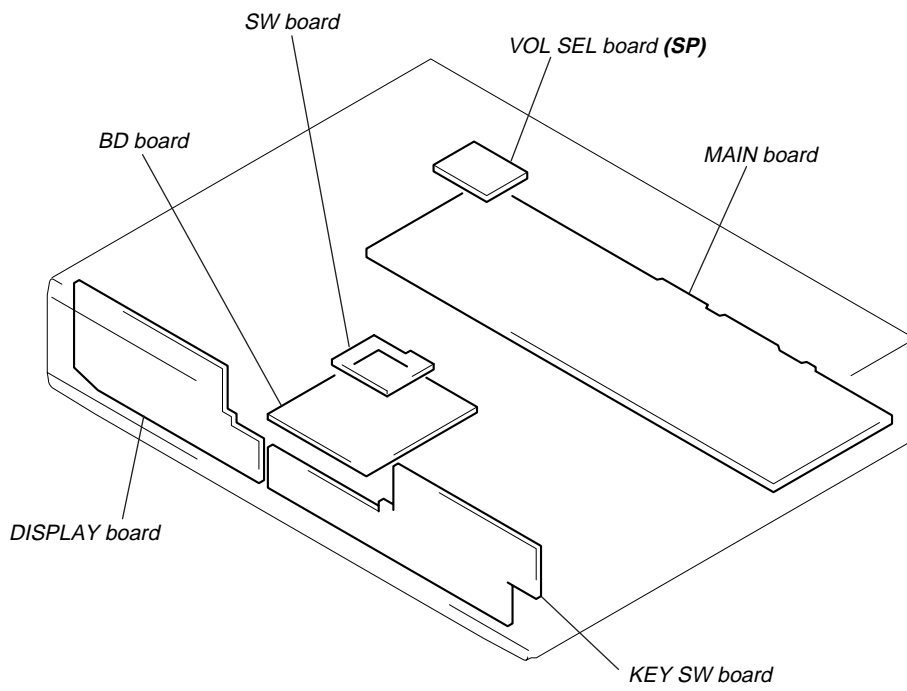

6-2. BLOCK DIAGRAMS
- BD SECTION -

DIGITAL SERVO SIGNAL PROCESSOR, DIGITAL SIGNAL PROCESSOR
EFM/ACIRC ENCODER/DECODER, SHOCK-PROOF MEMORY CONTROLLER,
ATRAC ENCODER/DECODER
IC121

- R-ch is omitted.
- Signal path
 - ▬ : PB
 - ▬ : REC
 - ▬ : PB (Digital out)
 - ▬ : REC (Digital in)

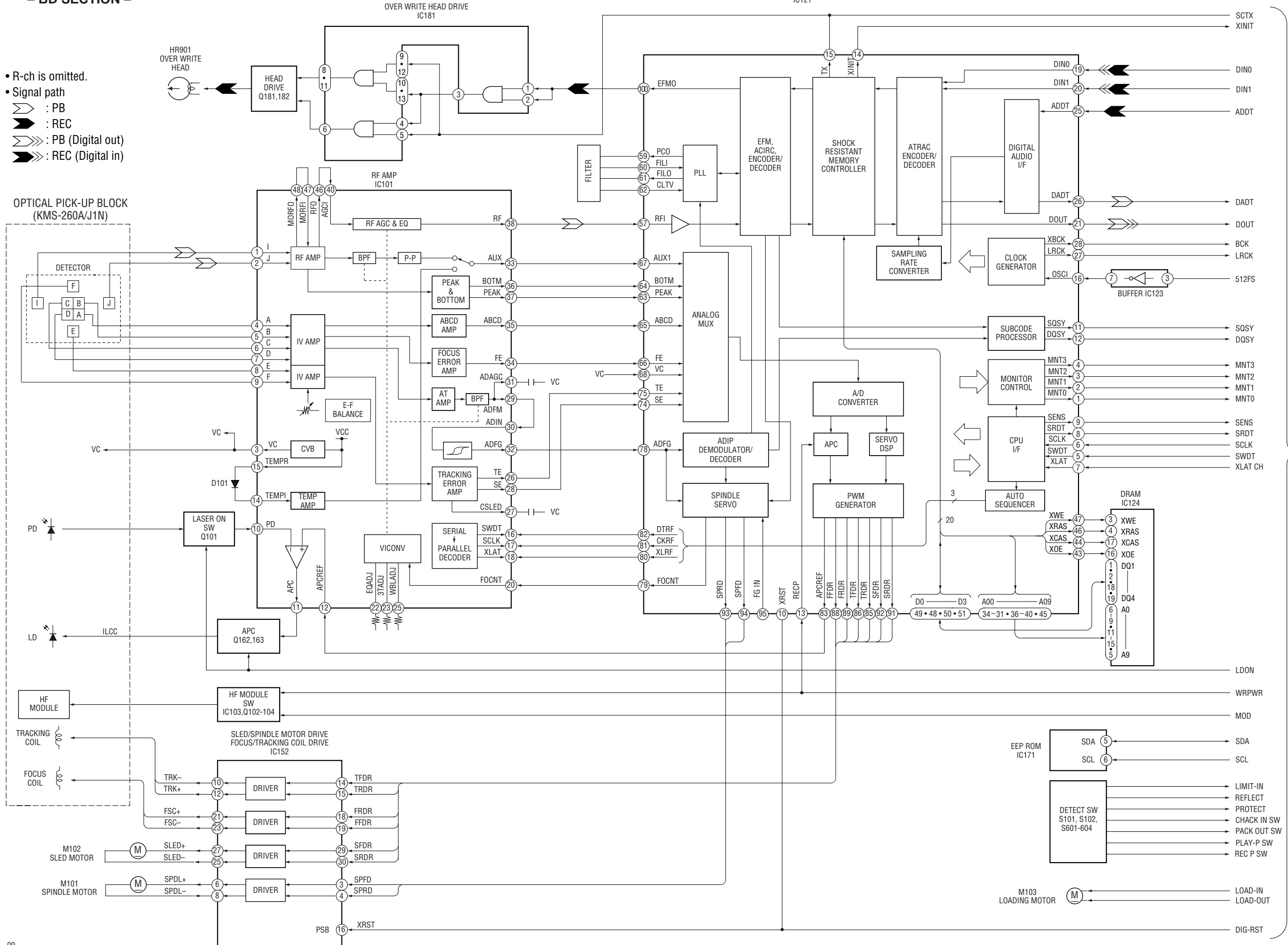

MAIN SECTION
(Page 31)

- MAIN SECTION -

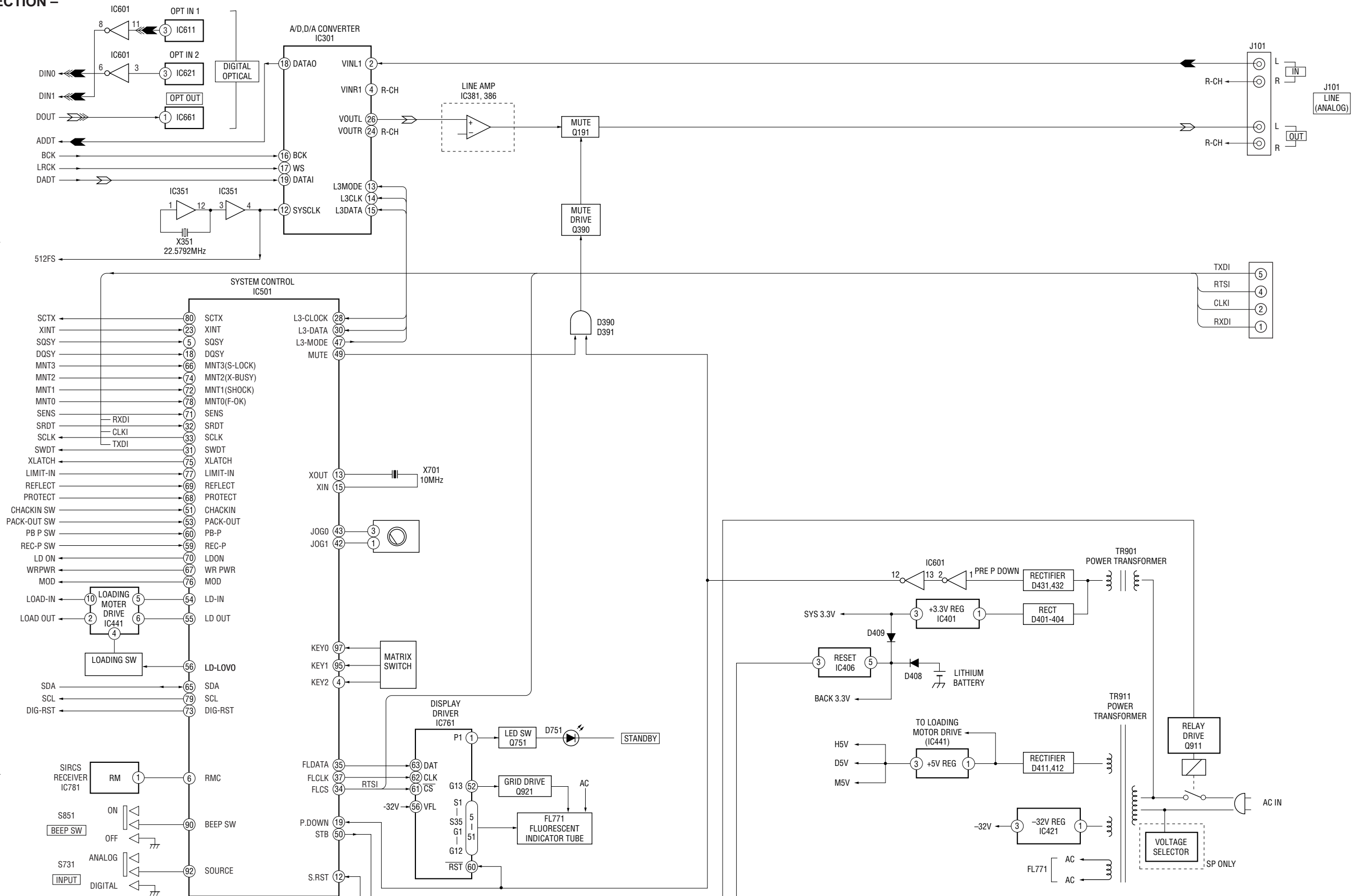

BD SECTION
(Page 30)

- R-ch is omitted.
- Signal path
- ▬ : PB
- ▬ : REC
- ▬ : PB (Digital out)
- ▬ : REC (Digital in)

THIS NOTE IS COMMON FOR PRINTED WIRING BOARDS AND SCHEMATIC DIAGRAMS.
(In addition to this, the necessary note is printed in each block.)

For schematic diagrams.

Note:

- All capacitors are in μF unless otherwise noted. pF: μpF 50 WV or less are not indicated except for electrolytics and tantalums.
- All resistors are in Ω and $1/4\text{W}$ or less unless otherwise specified.
- Δ : internal component.
- \square : panel designation.

Note:
 The components identified by mark Δ or dotted line with mark Δ are critical for safety.
 Replace only with part number specified.

Note:
 Les composants identifiés par une marque Δ sont critiques pour la sécurité.
 Ne les remplacer que par une pièce portant le numéro spécifié.

- $\text{B}+$: B+ Line.
- $\text{B}-$: B- Line.
- \square : adjustment for repair.
- no mark : STOP
- () : Play the test disc (TDYS-1)
- < > : REC
- * : Can not be measured.
- Voltages are taken with a VOM (Input impedance 10 M Ω). Voltage variations may be noted due to normal production tolerances.
- Waveforms are taken with an oscilloscope. Voltage variations may be noted due to normal production tolerances.
- Circled numbers refer to waveforms.
- Signal path.
 - \rightarrow : PB
 - \blacktriangleright : REC
 - \rightarrow : PB (DIGITAL OUT)
 - \blacktriangleright : REC (DIGITAL IN)
- Abbreviation
 - CND : Canadian model.
 - SP : Singapore model.

For printed wiring boards.

Note:

- \circ : parts extracted from the component side.
- \square : parts extracted from the conductor side.
- \circ : Through hole.
- \square : Pattern from the side which enables seeing. (The other layers' patterns are not indicated.)

Caution:
 Pattern face side: Parts on the pattern face side seen from the (Side B) pattern face are indicated.
 Parts face side: Parts on the parts face side seen from the (Side A) parts face are indicated.

Indication of transistor

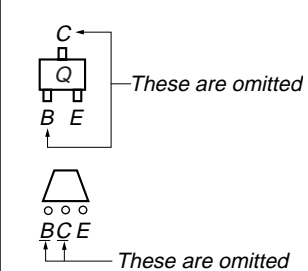

WAVEFORMS

- BD (1/2) SECTION -

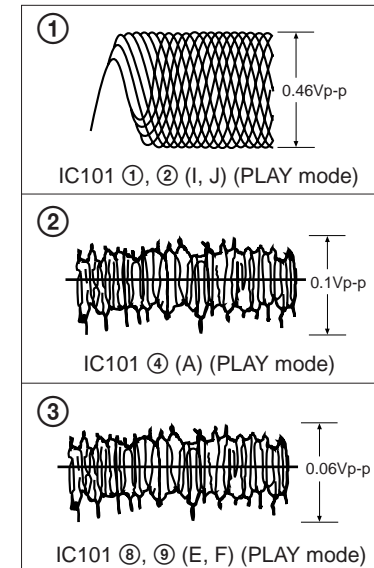

- MAIN SECTION -

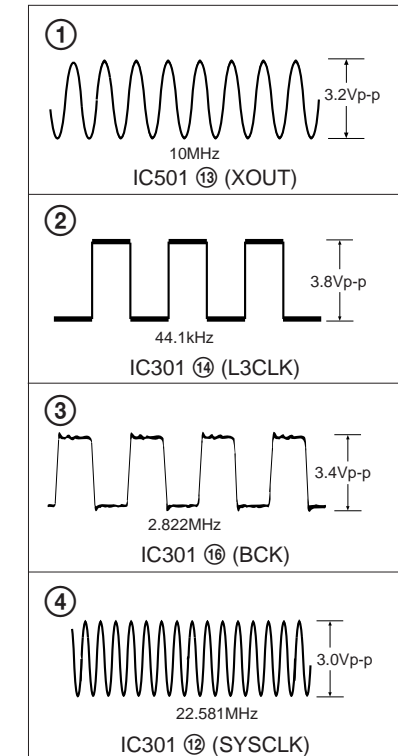

- BD (2/2) SECTION -

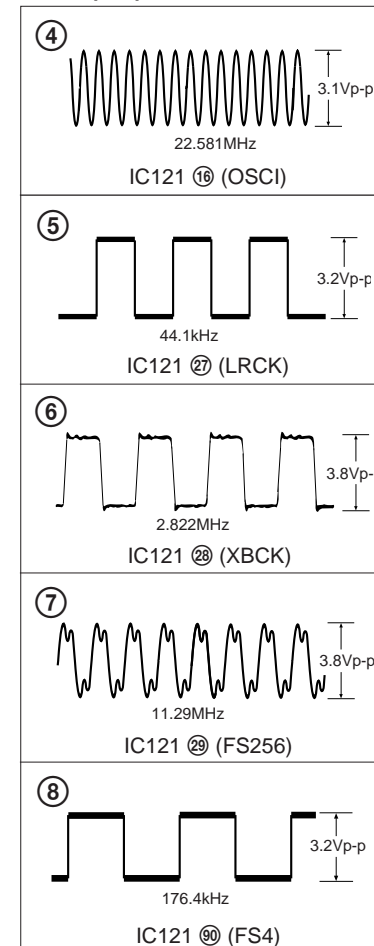

- DISPLAY SECTION -

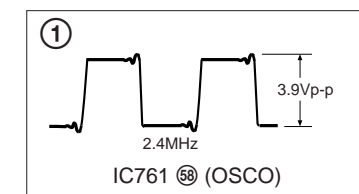

6-3. PRINTED WIRING BOARD – BD SECTION –
 • See page 28 for Circuit Boards Location.

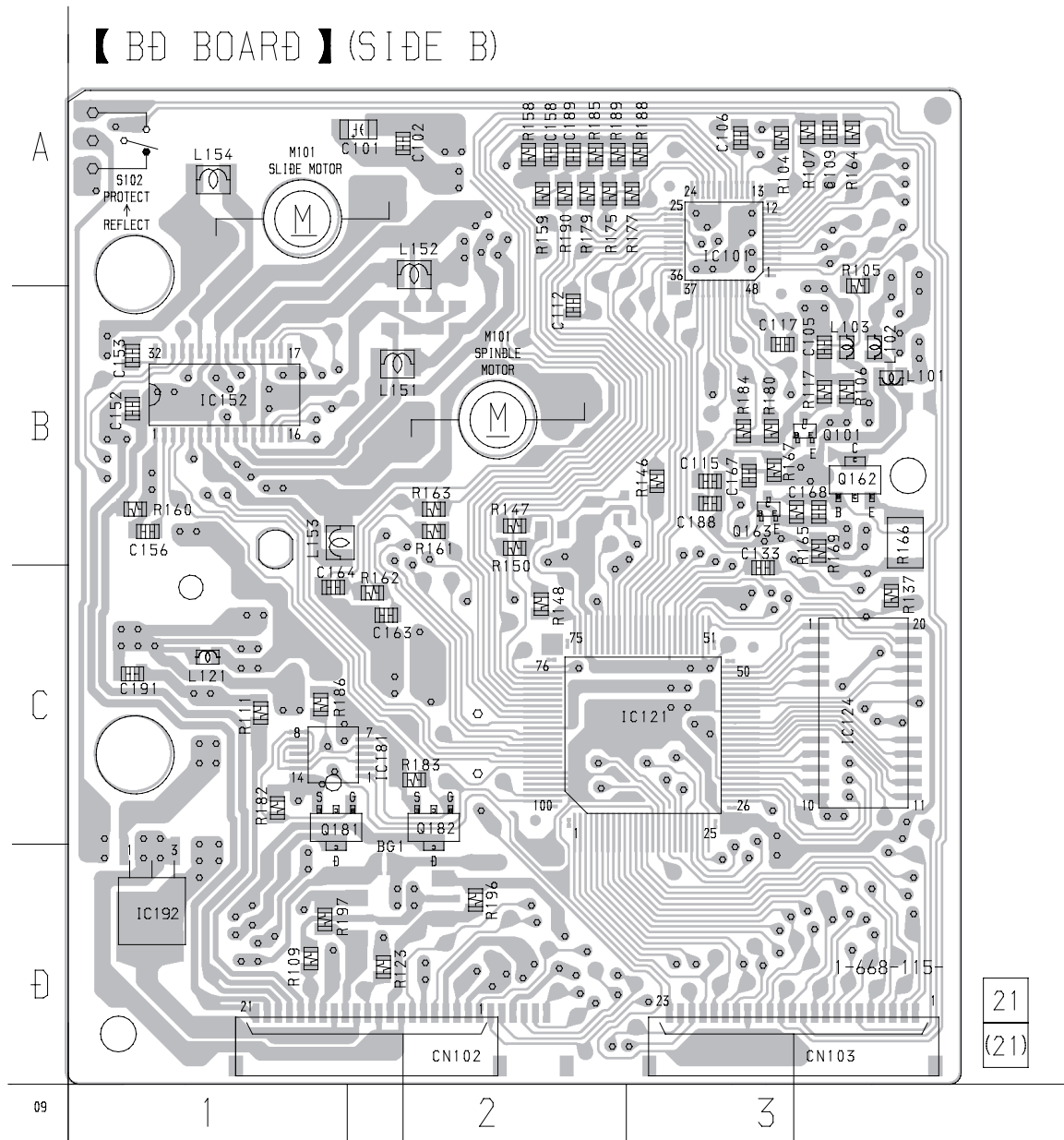
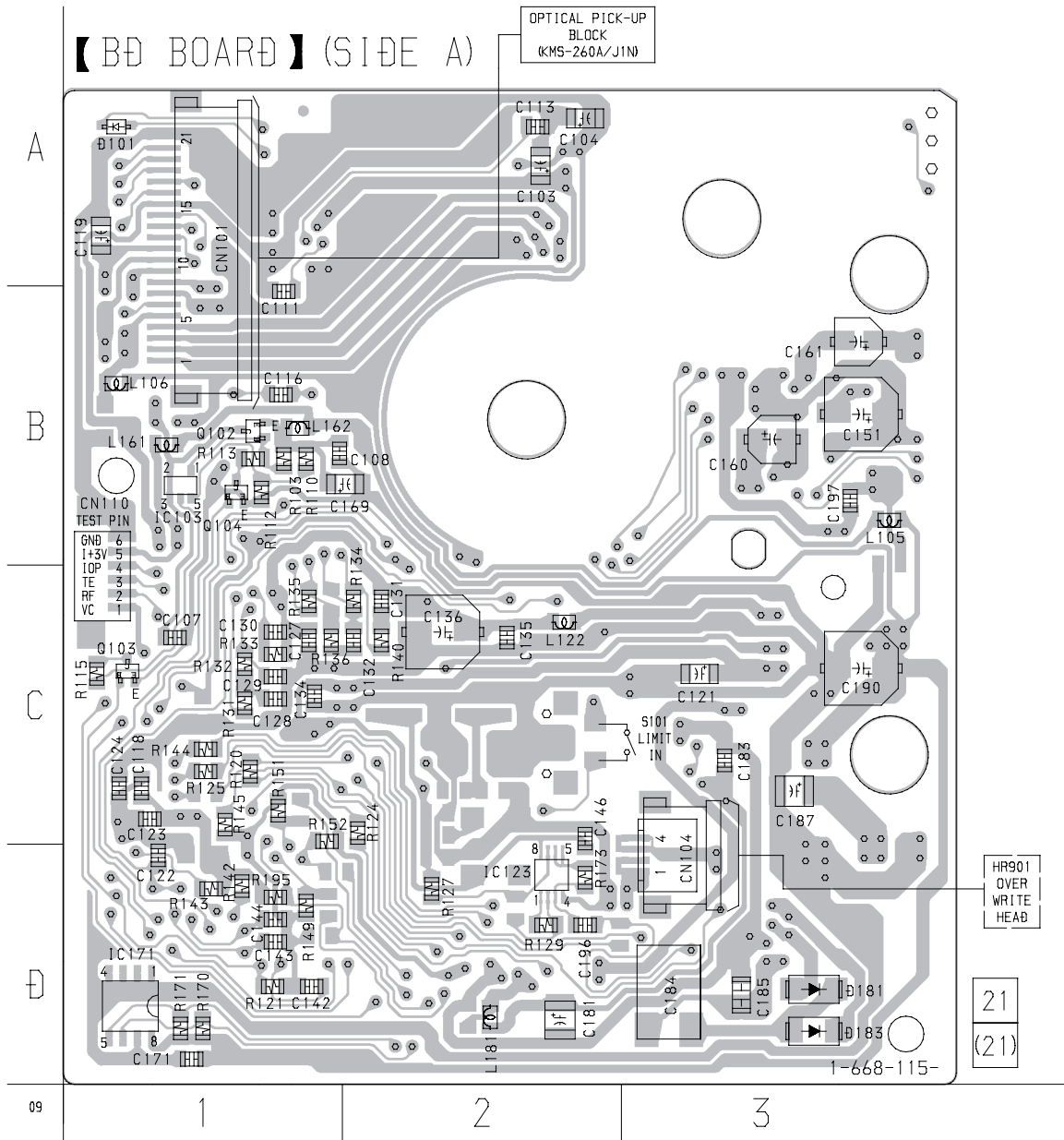

(Page 45) **A**

(Page 45) **B**

• Semiconductor Location

Ref. No.	Location
D101	A-1
D181	D-3
D183	D-3
IC103	B-1
IC123	D-2
IC171	D-1
Q102	B-1
Q103	B-1
Q104	B-1

• Semiconductor Location

Ref. No.	Location
IC101	A-3
IC121	C-3
IC124	C-3
IC152	B-1
IC181	C-1
IC192	D-1
Q101	B-3
Q162	B-3
Q163	B-3
Q181	C-1
Q182	C-2

6-4. SCHEMATIC DIAGRAM – BD (1/2) SECTION –

- See page 34 for Waveforms.
- See page 52 for IC Block Diagrams.
- See page 55 for IC Pin Functions.

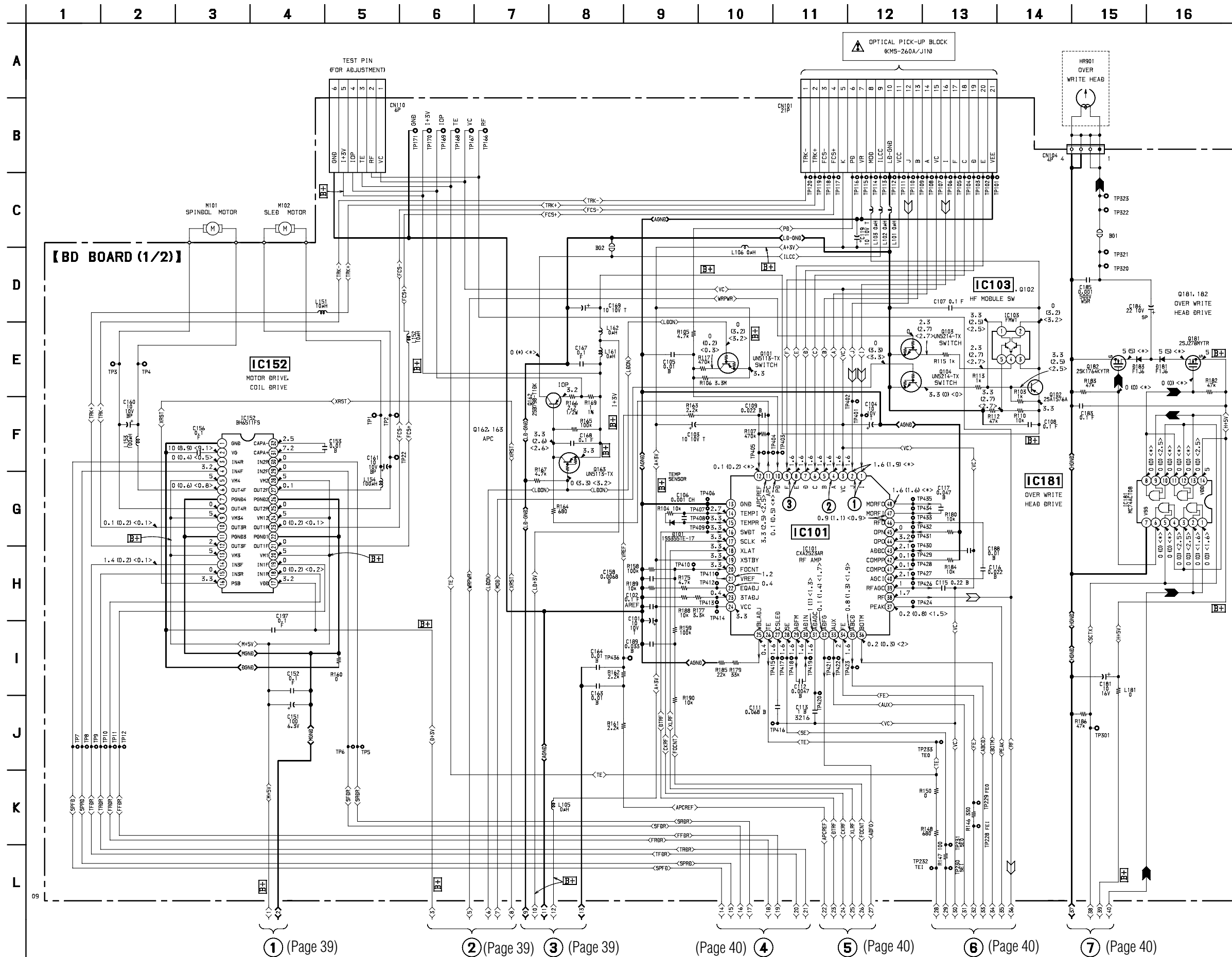

① (Page 39) ② (Page 39) ③ (Page 39) (Page 40) ④ ⑤ (Page 40) ⑥ (Page 40) ⑦ (Page 40)

6-5. SCHEMATIC DIAGRAM – BD (2/2) SECTION –

- See page 34 for Waveforms.
- See page 35 for Printed Wiring Board.

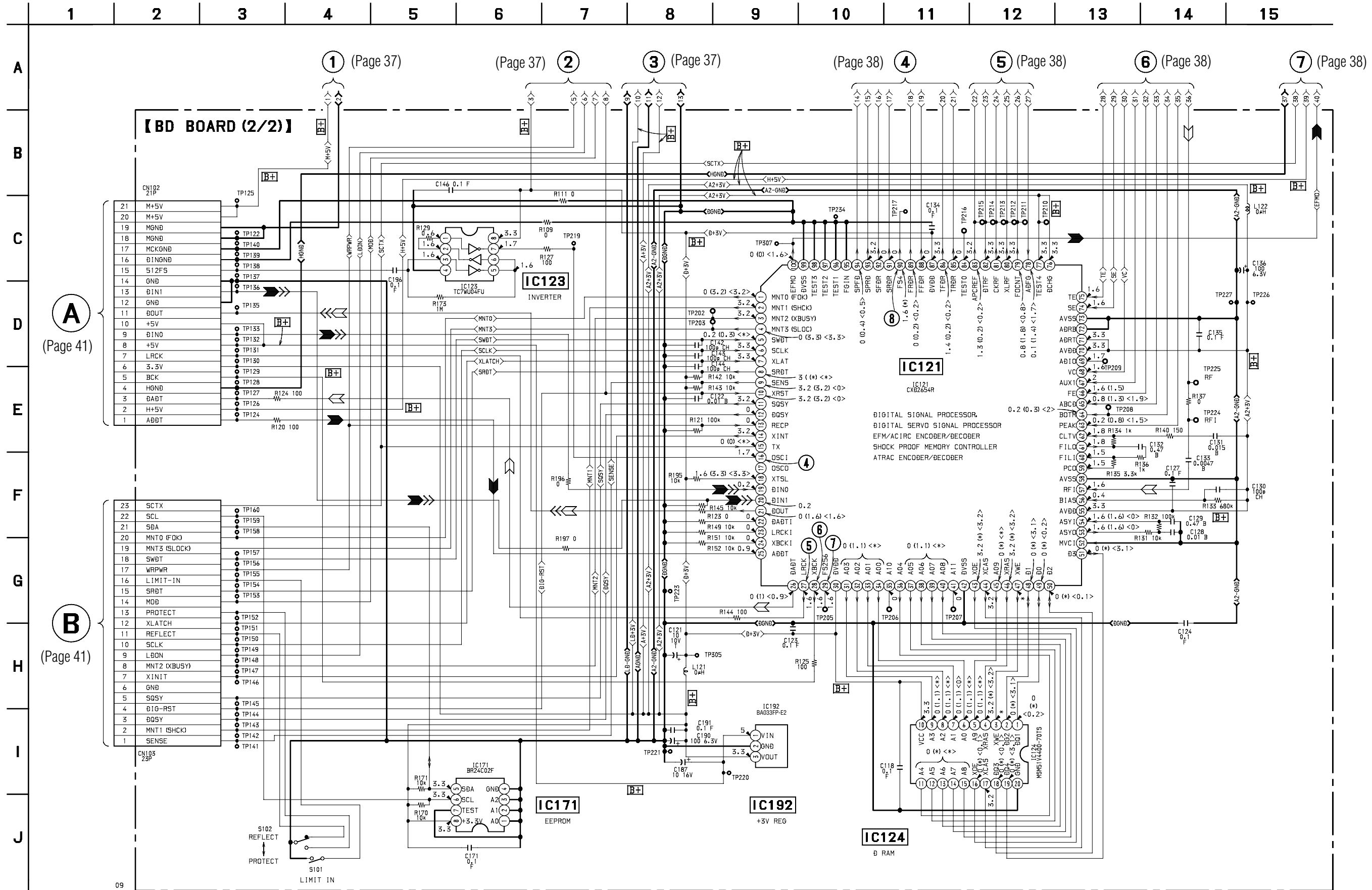

6-6. SCHEMATIC DIAGRAM – MAIN (1/2) SECTION –

- See page 34 for Waveforms.
- See page 45 for Printed Wiring Board.
- See page 59 for IC Pin Functions.

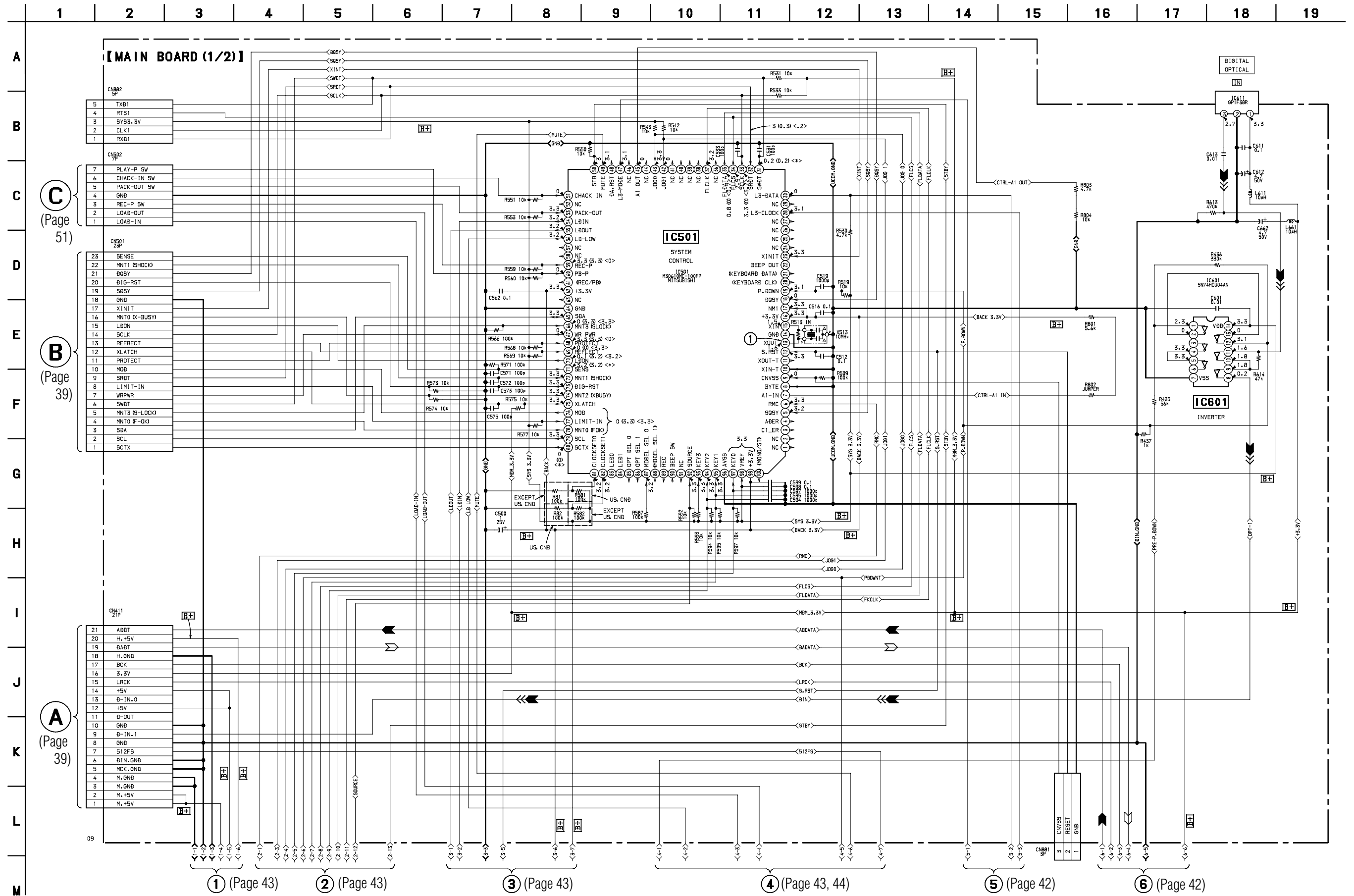

6-7. SCHEMATIC DIAGRAM – MAIN (2/2) SECTION –

- See page 34 for Waveforms.
- See page 54 for IC Block Diagrams.

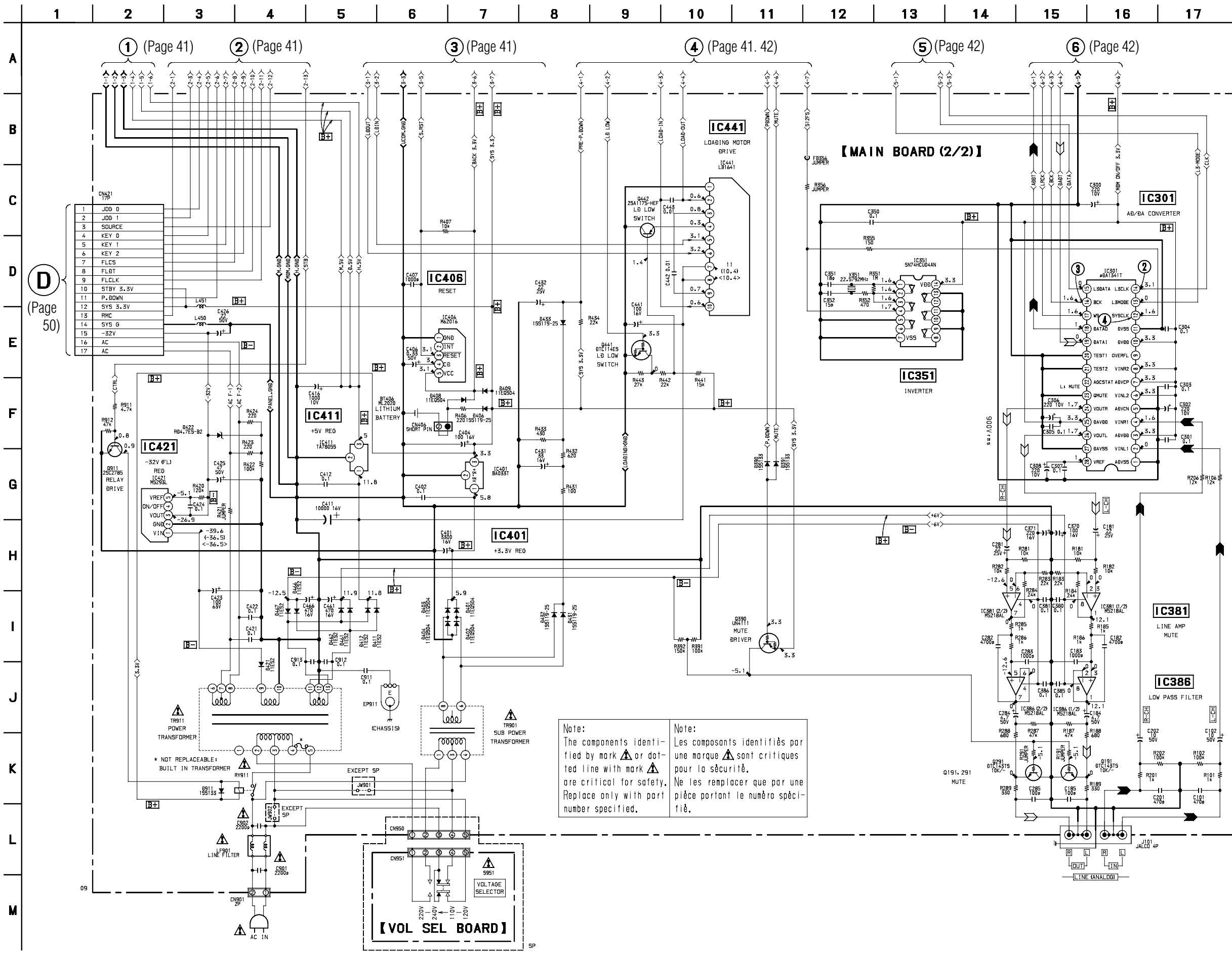

Note: The components identified by mark \blacktriangle or dotted line with mark \blacktriangle are critical for safety. Replace only with part number specified.

Note: Les composants identifiés par une marque \blacktriangle sont critiques pour la sécurité. Ne les remplacer que par une pièce portant le numéro spécifié.

6-8. PRINTED WIRING BOARD – MAIN SECTION –
 • See page 28 for Circuit Boards Location.

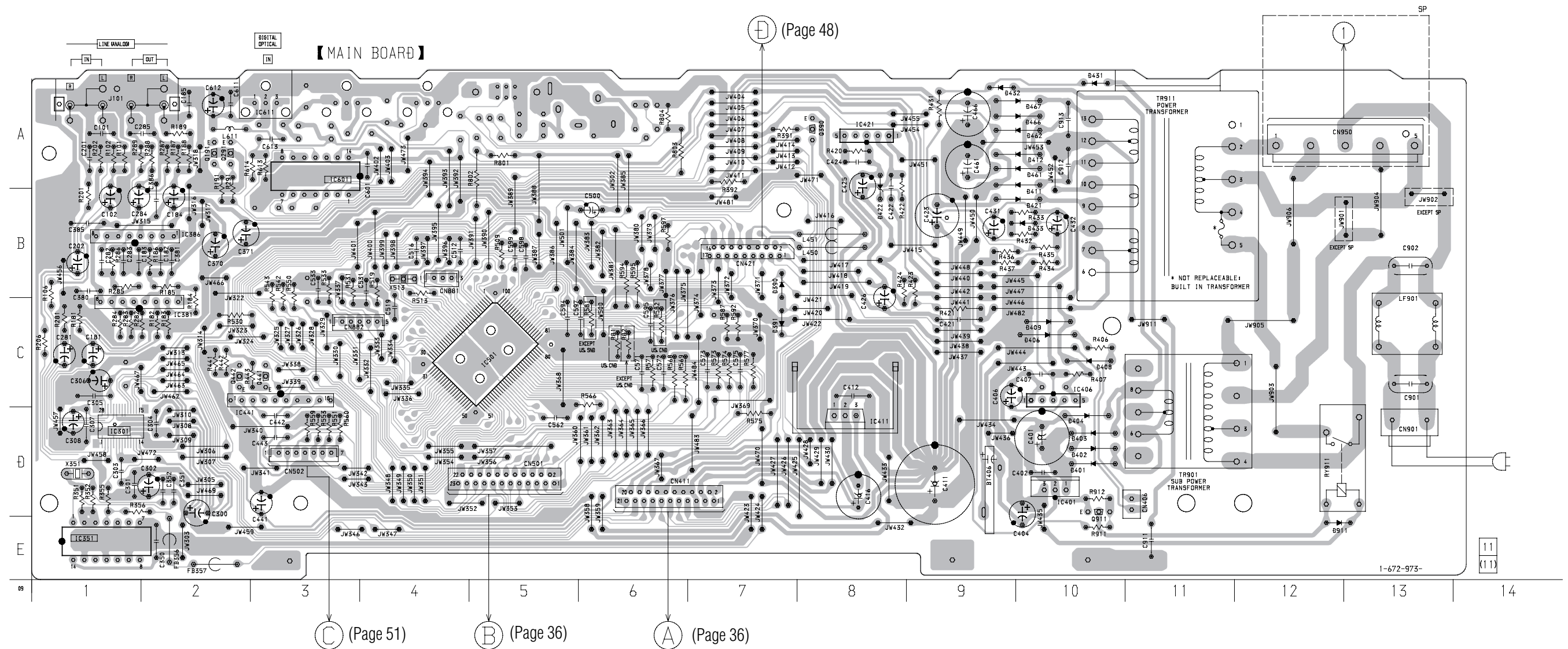

• Semiconductor Location

Ref. No.	Location	Ref. No.	Location
D390	B-7	IC301	D-1
D391	C-7	IC351	E-1
D401	D-10	IC381	C-2
D402	D-10	IC386	B-2
D403	D-10	IC401	D-10
D406	C-10	IC406	C-10
D408	C-10	IC411	D-8
D409	C-10	IC421	A-8
D411	A-10	IC441	C-3
D412	A-10	IC501	C-5
D421	B-10	IC601	A-3
D422	A-8	IC611	A-3
D431	A-10		
D432	A-9	Q191	A-2
D433	B-10	Q291	A-2
D461	A-10	Q390	A-8
D462	A-10	Q441	C-3
D466	A-10	Q442	C-2
D467	A-10	Q911	D-10
D911	E-12		

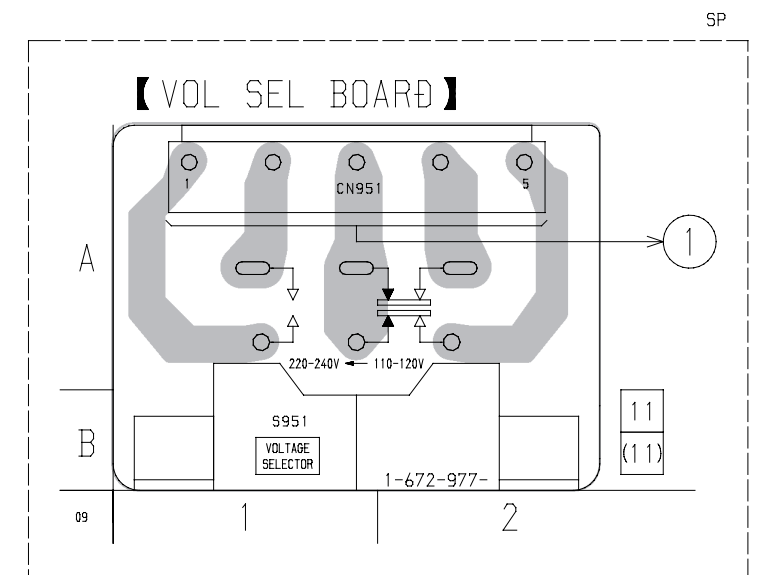

6-9. PRINTED WIRING BOARD – PANEL SECTION –
 • See page 28 for Circuit Boards Location.

【 DISPLAY BOARD 】

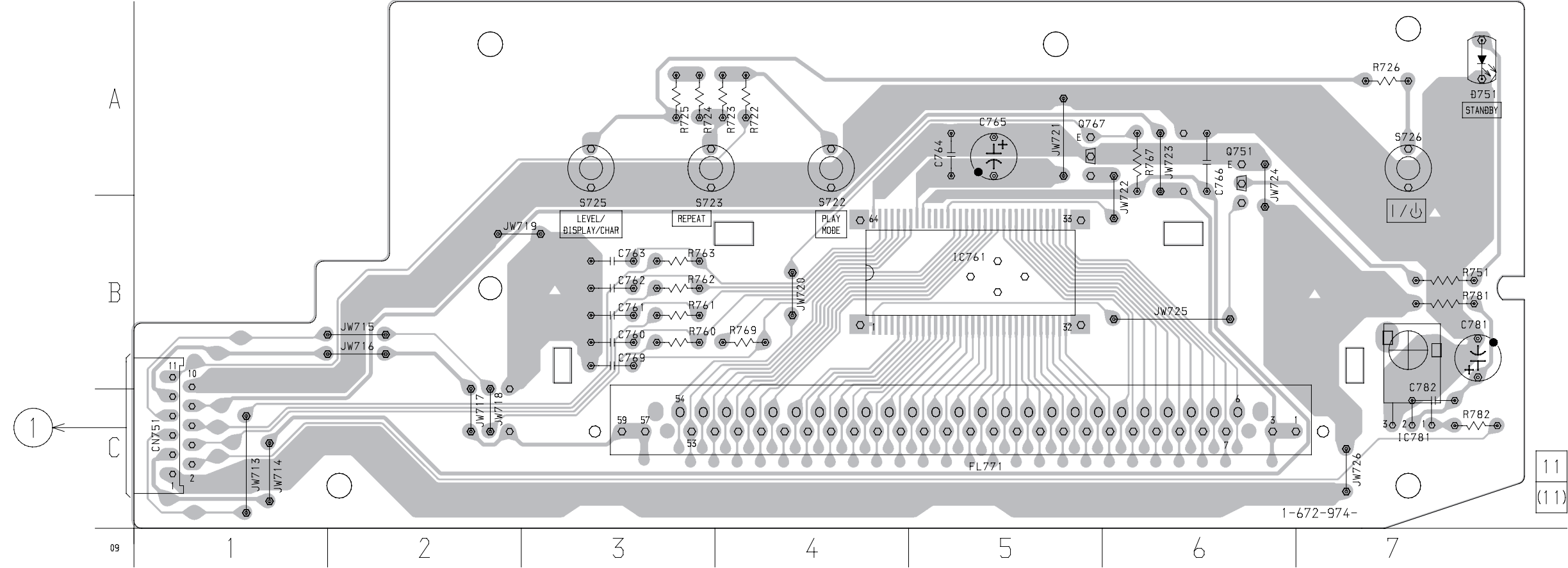

• Semiconductor Location

Ref. No.	Location
D751	A-1
IC761	B-5
IC781	B-7
Q751	A-6
Q767	A-5

【 KEY SW BOARD 】

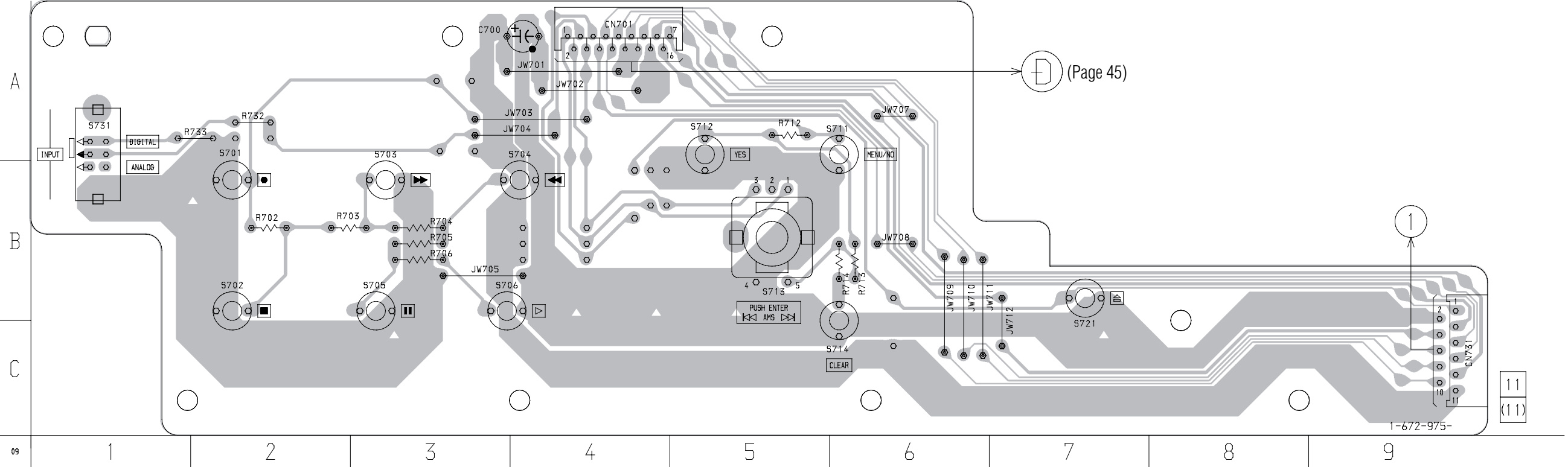

6-10. SCHEMATIC DIAGRAM – PANEL SECTION –
 • See page 34 for Waveforms.

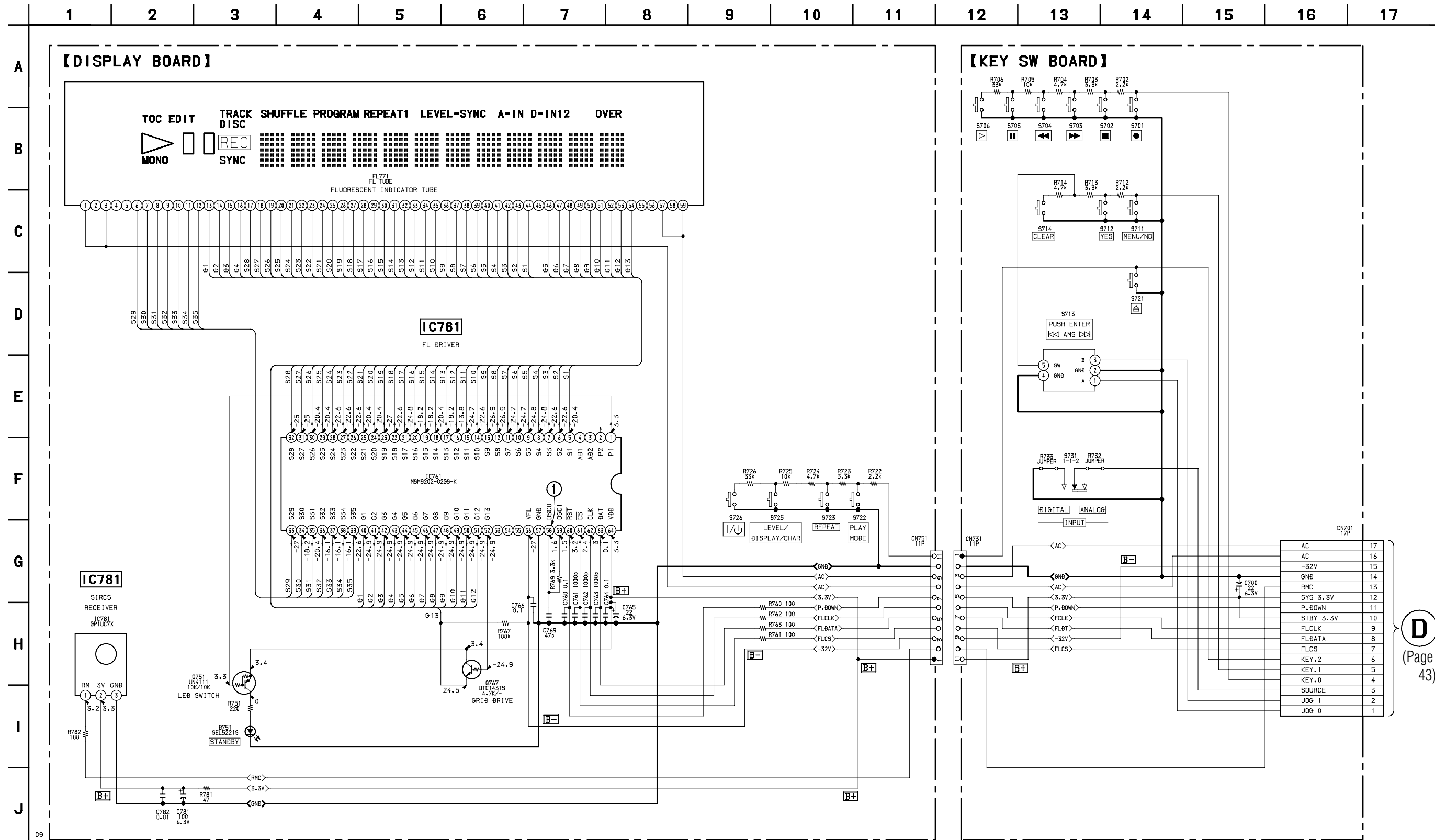

D
 (Page 43)

6-11. SCHEMATIC DIAGRAM – BD SWITCH SECTION –

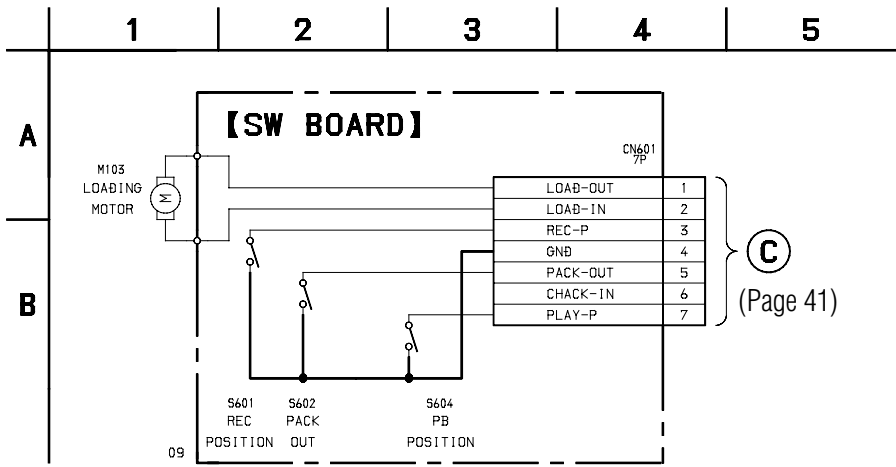

6-12. PRINTED WIRING BOARD – BD SWITCH SECTION –
• See page 28 for Circuit Boards Location.

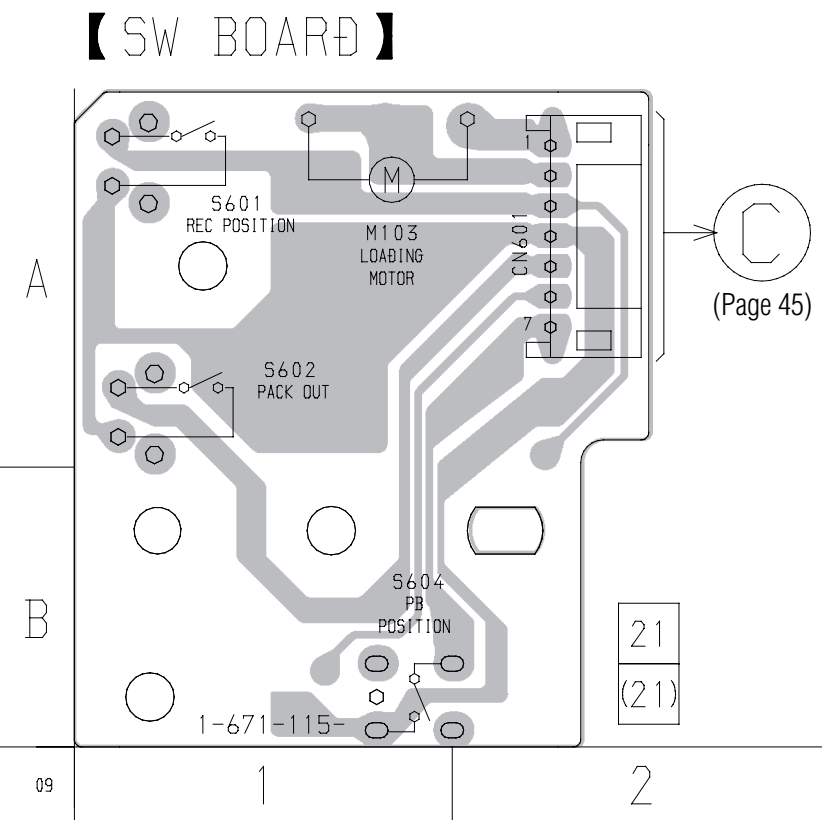

6-13. IC BLOCK DIAGRAMS

– BD Section –

IC101 CXA2523AR

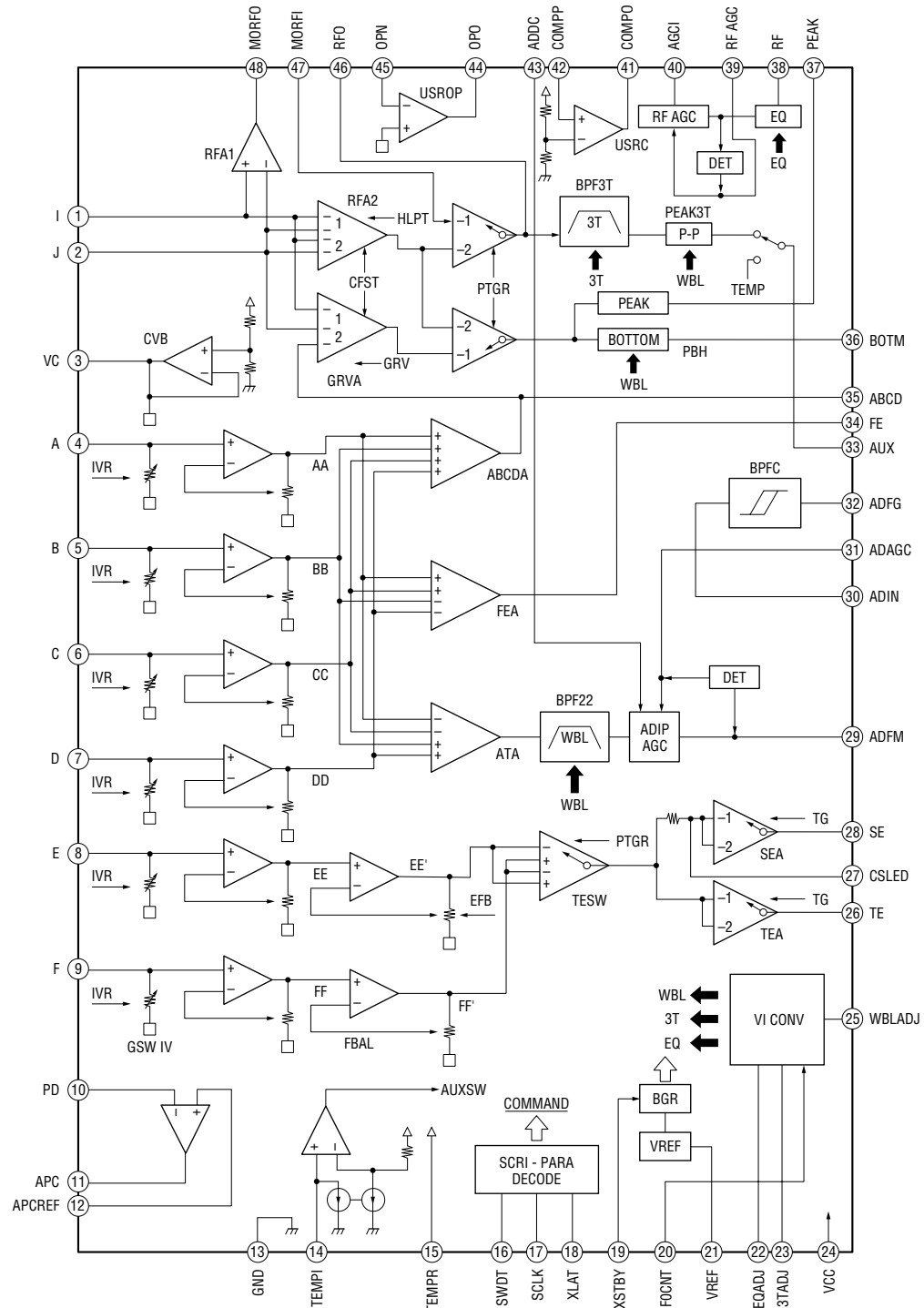

IC121 CXD2654R

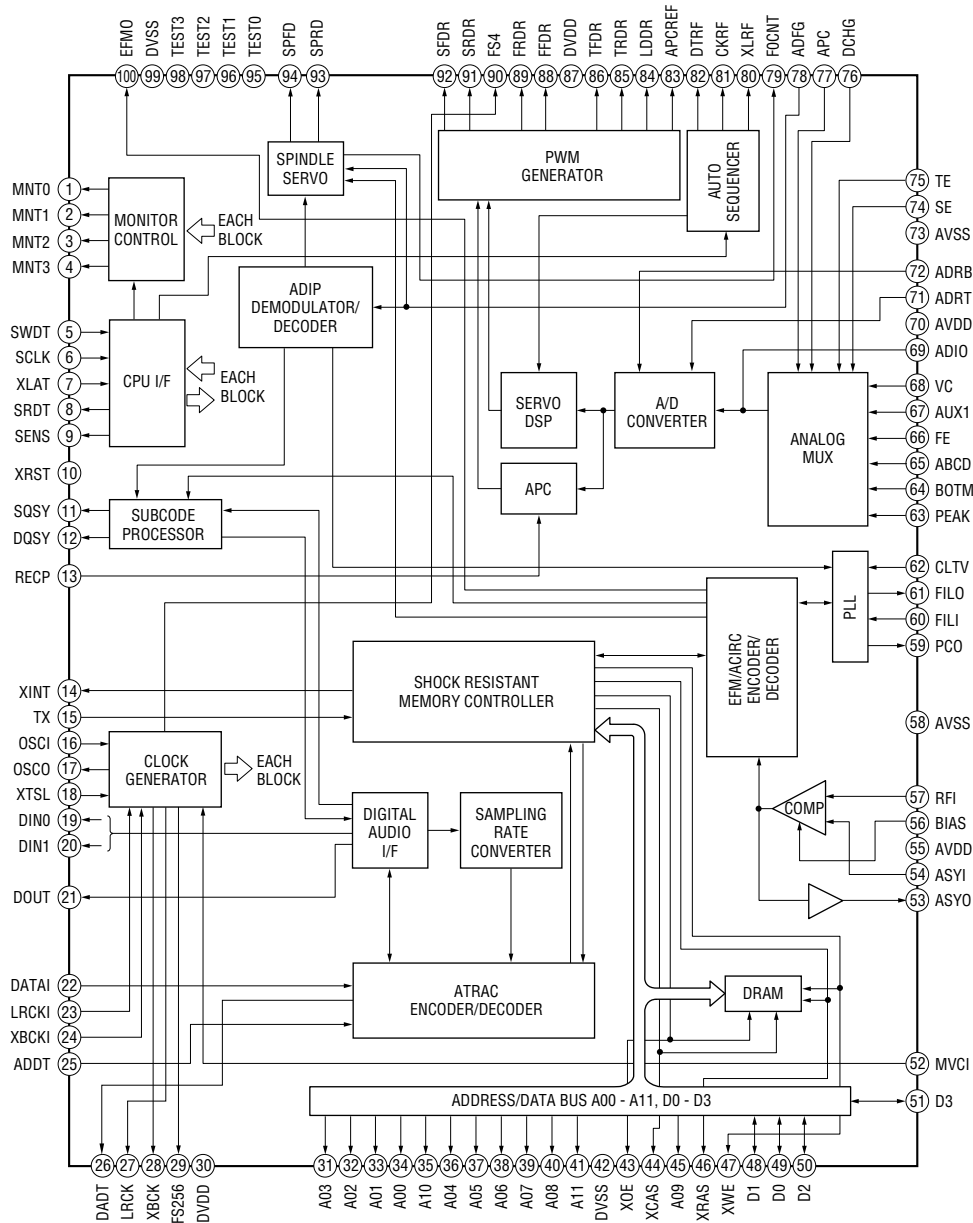

IC152 BH6511FS-E2

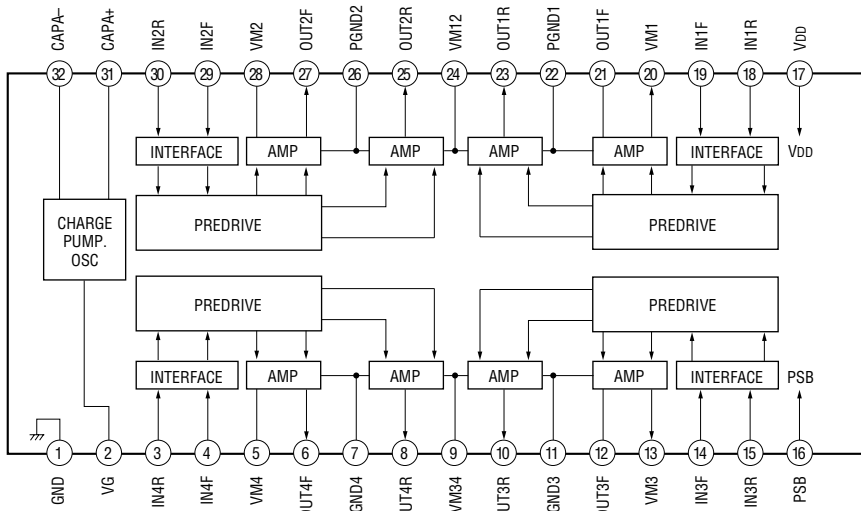

• MAIN section

IC301 UDA1341TS/N2

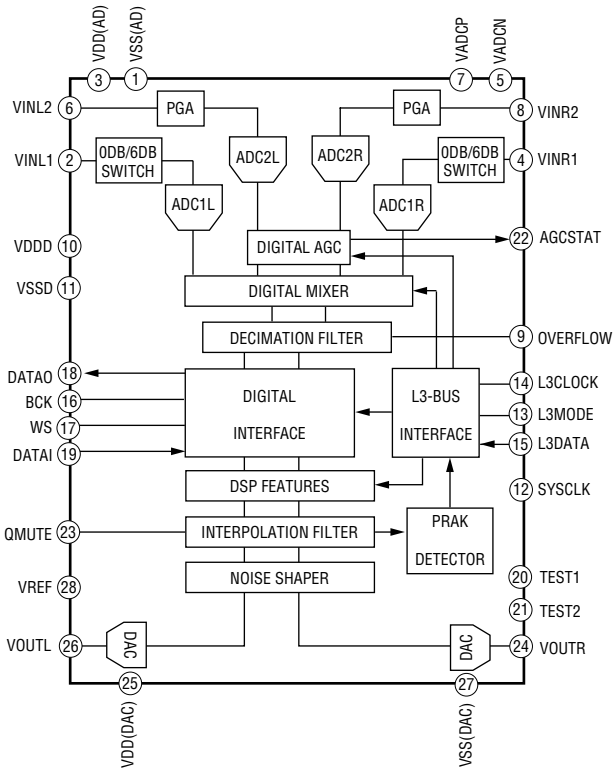

IC381 M5218AL

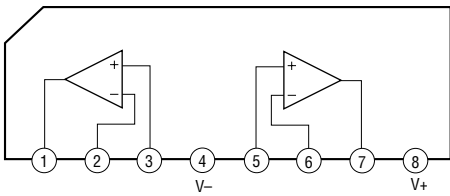

IC406 M62016L

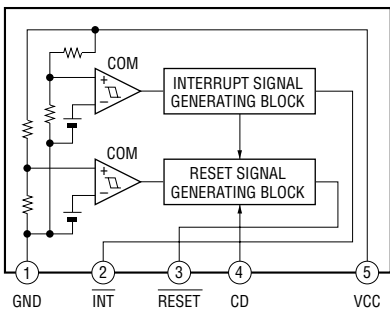

IC441 LB1641

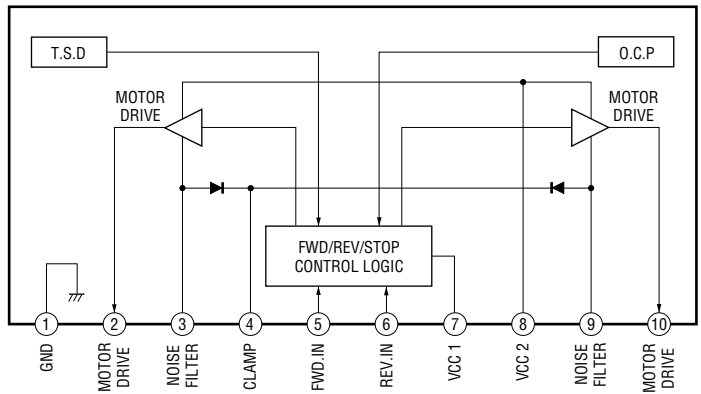

6-14. IC PIN FUNCTIONS

• IC101 RF Amplifier (CXA2523AR) (BD board)

Pin No.	Pin Name	I/O	Function
1	I	I	I-V converted RF signal I input
2	J	I	I-V converted RF signal J input
3	VC	O	Middle point voltage (+1.5V) generation output
4 to 9	A to F	I	Signal input from the optical pick-up detector
10	PD	I	Light amount monitor input
11	APC	O	Laser APC output
12	APCREF	I	Reference voltage input for setting laser power
13	GND	—	Ground
14	TEMPI	I	Temperature sensor connection
15	TEMPR	O	Reference voltage output for the temperature sensor
16	SWDT	I	Serial data input from the CXD2650R or CXD2652AR
17	SCLK	I	Serial clock input from the CXD2650R or CXD2652AR
18	XLAT	I	Latch signal input from the CXD2650R or CXD2652AR “L”: Latch
19	XSTBY	I	Stand by signal input “L”: Stand by
20	FOCNT	I	Center frequency control voltage input of BPF22, BPF3T, EQ from the CXD2650R or CXD2652AR
21	VREF	O	Reference voltage output (Not used)
22	EQADJ	I/O	Center frequency setting pin for the internal circuit EQ
23	3TADJ	I/O	Center frequency setting pin for the internal circuit BPF3T
24	Vcc	—	+3V power supply
25	WBLADJ	I/O	Center frequency setting pin for the internal circuit BPF22
26	TE	O	Tracking error signal output to the CXD2650R or CXD2652AR
27	CSLED	—	External capacitor connection pin for the sled error signal LPF
28	SE	O	Sled error signal output to the CXD2650R or CXD2652AR
29	ADFM	O	FM signal output of ADIP
30	ADIN	I	ADIP signal comparator input ADFM is connected with AC coupling
31	ADAGC	—	External capacitor connection pin for AGC of ADIP
32	ADFG	O	ADIP duplex signal output to the CXD2650R or CXD2652AR
33	AUX	O	I ₃ signal/temperature signal output to the CXD2650R or CXD2652AR (Switching with a serial command)
34	FE	O	Focus error signal output to the CXD2650R or CXD2652AR
35	ABCD	O	Light amount signal output to the CXD2650R or CXD2652AR
36	BOTM	O	RF/ABCD bottom hold signal output to the CXD2650R or CXD2652AR
37	PEAK	O	RF/ABCD peak hold signal output to the CXD2650R or CXD2652AR
38	RF	O	RF equalizer output to the CXD2650R or CXD2652AR
39	RFAGC	—	External capacitor connection pin for the RF AGC circuit
40	AGCI	I	Input to the RF AGC circuit The RF amplifier output is input with AC coupling
41	COMPO	O	User comparator output (Not used)
42	COMPP	I	User comparator input (Fixed at “L”)
43	ADDC	I/O	External capacitor pin for cutting the low band of the ADIP amplifier
44	OPO	O	User operation amplifier output (Not used)
45	OPN	I	User operation amplifier inversion input (Fixed at “L”)
46	RFO	O	RF amplifier output
47	MORFI	I	Groove RF signal is input with AC coupling
48	MORFO	O	Groove RF signal output

- Abbreviation
APC: Auto Power Control
AGC: Auto Gain Control

• IC121 Digital Signal Processor, Digital Servo Signal Processor, EFM/ACIRC Encoder/Decoder, Shock-proof Memory Controller, ATRAC Encoder/Decoder, 2M Bit DRAM (CXD2654R) (BD board)

Pin No.	Pin Name	I/O	Function
1	MNT0 (FOK)	O	FOK signal output to the system control (monitor output) “H” is output when focus is on
2	MNT1 (SHCK)	O	Track jump detection signal output to the system control (monitor output)
3	MNT2 (XBUSY)	O	Monitor 2 output to the system control (monitor output)
4	MNT3 (SLOC)	O	Monitor 3 output to the system control (monitor output)
5	SWDT	I	Writing data signal input from the system control
6	SCLK	I (S)	Serial clock signal input from the system control
7	XLAT	I (S)	Serial latch signal input from the system control
8	SRDT	O (3)	Reading data signal output to the system control
9	SENS	O (3)	Internal status (SENSE) output to the system control
10	XRST	I (S)	Reset signal input from the system control “L”: Reset
11	SQSY	O	Subcode Q sync (SCOR) output to the system control “L” is output every 13.3 msec. Almost all, “H” is output
12	DQSY	O	Digital In U-bit CD format or MD format subcode Q sync (SCOR) output to the system control
13	RECP	I	Laser power switching input from the system control “H”: Recording, “L”: Playback
14	XINT	O	Interrupt status output to the system control
15	TX	I	Recording data output enable input from the system control
16	OSCI	I	System clock input (512Fs=22.5792 MHz)
17	OSCO	O	System clock output (512Fs=22.5792 MHz) (Not used)
18	XTSL	I	System clock frequency setting “L”: 45.1584 MHz, “H”: 22.5792 MHz (Fixed at “H”)
19	DIN0	I	Digital audio input (Optical input)
20	DIN1	I	Digital audio input (Optical input)
21	DOUT	O	Digital audio output (Optical output)
22	DADTI	I	Serial data input
23	LRCKI	I	LR clock input “H” : Lch, “L” : R ch
24	XBCKI	I	Serial data clock input
25	ADDT	I	Data input from the A/D converter
26	DADT	O	Data output to the D/A converter
27	LRCK	O	LR clock output for the A/D and D/A converter (44.1 kHz)
28	XBCK	O	Bit clock output to the A/D and D/A converter (2.8224 MHz)
29	FS256	O	11.2896 MHz clock output (Not used)
30	DVDD	—	+3V power supply (Digital)
31 to 34	A03 to A00	O	DRAM address output
35	A10	O	DRAM address output (Not used)
36 to 40	A04 to A08	O	DRAM address output
41	A11	O	DRAM address output (Not used)
42	DVSS	—	Ground (Digital)
43	XOE	O	Output enable output for DRAM
44	XCAS	O	$\overline{\text{CAS}}$ signal output for DRAM
45	A09	O	Address output for DRAM
46	XRAS	O	$\overline{\text{RAS}}$ signal output for DRAM
47	XWE	O	Write enable signal output for DRAM (Used : CXD2652AR, Not used : CXD2650R)

* I (S) stands for Schmidt input, I (A) for analog input, O (3) for 3-state output, and O (A) for analog output in the column I/O

Pin No.	Pin Name	I/O	Function
48	D1	I/O	Data input/output for DRAM
49	D0	I/O	
50, 51	D2, D3	I/O	
52	MVCI	I (S)	Clock input from an external VCO (Fixed at "L")
53	ASYO	O	Playback EFM duplex signal output
54	ASYI	I (A)	Playback EFM comparator slice level input
55	AVDD	—	+3V power supply (Analog)
56	BIAS	I (A)	Playback EFM comparator bias current input
57	RFI	I (A)	Playback EFM RF signal input
58	AVSS	—	Ground (Analog)
59	PCO	O (3)	Phase comparison output for the recording/playback EFM master PLL
60	FILI	I (A)	Filter input for the recording/playback EFM master PLL
61	FILO	O (A)	Filter output for the recording/playback EFM master PLL
62	CLTV	I (A)	Internal VCO control voltage input for the recording/playback EFM master PLL
63	PEAK	I (A)	Light amount signal peak hold input from the CXA2523R
64	BOTM	I (A)	Light amount signal bottom hold input from the CXA2523R
65	ABCD	I (A)	Light amount signal input from the CXA2523R
66	FE	I (A)	Focus error signal input from the CXA2523R
67	AUX1	I (A)	Auxiliary A/D input
68	VC	I (A)	Middle point voltage (+1.5V) input from the CXA2523R
69	ADIO	O (A)	Monitor output of the A/D converter input signal (Not used)
70	AVDD	—	+3V power supply (Analog)
71	ADRT	I (A)	A/D converter operational range upper limit voltage input (Fixed at "H")
72	ADRB	I (A)	A/D converter operational range lower limit voltage input (Fixed at "L")
73	AVSS	—	Ground (Analog)
74	SE	I (A)	Sled error signal input from the CXA2523R
75	TE	I (A)	Tracking error signal input from the CXA2523R
76	DCHG	I (A)	Connected to +3V power supply
77	APC	I (A)	Error signal input for the laser digital APC (Fixed at "L")
78	ADFG	I (S)	ADIP duplex FM signal input from the CXA2523R (22.05 ± 1 kHz)
79	F0CNT	O	Filter f ₀ control output to the CXA2523R
80	XLRF	O	Control latch output to the CXA2523R
81	CKRF	O	Control clock output to the CXA2523R
82	DTRF	O	Control data output to the CXA2523R
83	APCREF	O	Reference PWM output for the laser APC
84	TEST0	O	PWM output for the laser digital APC (Not used)
85	TRDR	O	Tracking servo drive PWM output (-)

- Abbreviation

EFM: Eight to Fourteen Modulation

PLL : Phase Locked Loop

VCO: Voltage Controlled Oscillator

Pin No.	Pin Name	I/O	Function
86	TFDR	O	Tracking servo drive PWM output (+)
87	DVDD	—	+3V power supply (Digital)
88	FFDR	O	Focus servo drive PWM output (+)
89	FRDR	O	Focus servo drive PWM output (-)
90	FS4	O	176.4 kHz clock signal output (X'tal) (Not used)
91	SRDR	O	Sled servo drive PWM output (-)
92	SFDR	O	Sled servo drive PWM output (+)
93	SPRD	O	Spindle servo drive PWM output (-)
94	SPFD	O	Spindle servo drive PWM output (+)
95	FGIN	I (S)	Test input (Fixed at "L")
96 to 98	TEST1 to TEST3	I	
99	DVSS	—	Ground (Digital)
100	EFMO	O	EFM output when recording

- Abbreviation

EFM: Eight to Fourteen Modulation

• IC501 System Control (M30620MC-400FP) (MAIN board)

Pin No.	Pin Name	I/O	Function
1, 2	NC	O	Not used (Fixed at "L")
3	C1ER	O	C1 error rate voltage output (Fixed at "L")
4	ADER	O	AD error rate voltage output (Fixed at "L")
5	SQSY	I	ADIP sync or subcode Q sync input from CXD2654R
6	RMC	I	Remote controls
7	A1 IN	I	A1 Control input (Fixed at "L")
8	BYTE	I	Data bus changed input (Fixed at "L")
9	CNVSS	—	Ground
10	XIN-T	O	Not used (Fixed at "L")
11	XOUT-T	O	Not used (Fixed at "L")
12	S.RST	I	System rest input
13	XOUT	O	Main clock output (7.0MHz)
14	GND	—	Ground
15	XIN	I	Main clock input (7.0MHz)
16	+3.3V	—	+3.3V power supply
17	NMI	I	(Fixed at "H")
18	DQSY	I	Digital in sync input
19	P.DOWN	I	Power down detection input "L": Power down
20	KEYBOARD CLK	O	Not used
21	KEYBOARD DATA	O	Not used
22	BEEP OUT	—	Not used
23	XINIT	I	Interrupt status input from CXD2654R
24 to 27	NC	O	Not used
28	L3 CLOCK	O	Serial clock signal output to IC301
29	NC	O	Not used
30	LC DATA	O	Serial data signal output to IC301
31	SWDT	O	Writing data signal output to the serial bus
32	SRDT	I	Reading data signal input from the serial bus
33	SCLK	O	Clock signal output to the serial bus
34	FLCS	O	Chip select signal output to the display driver
35	FLDATA	O	Serial data signal output to the display driver
36	NC	O	Not used (Fixed at "L")
37	FLCLK	O	Serial clock signal output to the display driver
38 to 41	NC	O	Not used
42, 43	JOG1, JOG0	I	Jog dial pulse input from the rotary encoder
44	NC	O	Not used
45	A1 OUT	O	A1 output
46	NC	O	Not used
47	L3 MODE	O	Serial mode signal output to IC301
48	DA.RST	O	Not used Reset: "L"
49	MUTE	O	DA line out muting output Mute: "L"
50	STB	O	Strobe signal output to the power supply circuit Power supply ON: "H", stand by: "L"
51	CHACK IN	I	Detection input from the chucking-in switch "L": Chucking
52	NC	I	Not used (Fixed at "L")
53	PACK-OUT	I	Detection input from the loading out switch. Loaded out position: "L", Others: "H"
54	LDIN	I	Loading motor control input
55	LDOUT	O	Loading motor control output
56	LD-LOW	O	Loading motor voltage control output Low voltage: "H"
57, 58	NC	O	Not used (Fixed at "L")
59	REC-P	I	Detection signal input from the recording position detection switch

Pin No.	Pin Name	I/O	Function
60	PB-P	I	Detection signal input from the playback position detection switch
61	REC/PB	O	Not used Write: "H"
62	+3.3V	—	+3.3V power supply
63	NC	O	Not used (Fixed at "L")
64	GND	—	Ground
65	SDA	I/O	Data signal input/output pin with the backup memory
66	MNT3 (SLOCK)	I	In the state of spindle srvo lock from the CXD2564R
67	WR PWR	O	Write power ON/OFF output
68	PROTECT	I	Recording-protection claw detection input from the protection detection switch Protect: "H"
69	REFLECT	I	Disk reflection rate detection input from the reflect detection switch Disk with low reflection rate: "H"
70	LDON	O	Laser ON/OFF control output "H": Laser ON
71	SENS	I	Internal status (SENSE) input from the CXD2654R
72	NMT1 (SHOCK)	I	Track jump signal input from the CXD2654R
73	DIG-RST	O	Digital rest signal output to the CXD2654R and motor driver Reset: "L"
74	MNT2 (XBUSY)	I	In the state of executive command from the CXD2654R
75	XLATCH	O	Latch signal output to the serial bus
76	MOD	O	Laser modulation switching signal output
77	LIMIT-IN	I	Detection input from the limit switch Sled limit-In: "L"
78	MNT0 (FOK)	I	Focus OK signal input from the CXD26504R "H" is input when focus is on
79	SCL	O	Clock signal output to the backup memory
80	SCTX	O	Writing data transmission timing output to the CXD2654R Shared with the magnetic head ON/OFF output
81	CLKSET0	I	Clock destination select pin US, Canadian: "L", Except US, Canadian : "H"
82	CLKSET1	I	Clock destination select pin US, Canadian: "H", Except US, Canadian : "L"
83	LED0	O	Not used
84	LED1	O	
85	OPT DEL	O	
86	OPT SEL	O	
87	MODE SEL 0	I	Mode selector
88	MODE SEL 1	O	Not used
89	$\overline{\text{REC}}$	O	
90	BEEP SW	O	
91	NC	I	
92	SOURCE	I	Input source change input (A/D input)
93 to 95	KEY 3 to KEY 1	I	Key input pin (A/D input)
96	AVSS	—	Ground (Analog)
97	KEY0	I	Key input pin (A/D input)
98	VREF	—	A/D reference voltage (Fixed at "H")
99	+3.3V	—	+3.3V power supply
100	MONO/ST	I	Monaural, stereo change input Monaural: "H"

SECTION 7 EXPLODED VIEWS

NOTE:

- Items marked “*” are not stocked since they are seldom required for routine service. Some delay should be anticipated when ordering these items.
- The mechanical parts with no reference number in the exploded views are not supplied.
- Hardware (# mark) list and accessories and packing materials are given in the last of this parts list.

- Abbreviation
CND : Canadian model
HK : Hong Kong model
SP : Singapore model
AUS : Australian model

The components identified by mark \triangle or dotted line with mark \triangle are critical for safety. Replace only with part number specified.

Les composants identifiés par une marque \triangle sont critiques pour la sécurité. Ne les remplacer que par une pièce portant le numéro spécifié.

7-1. CASE AND BACK PANEL SECTION

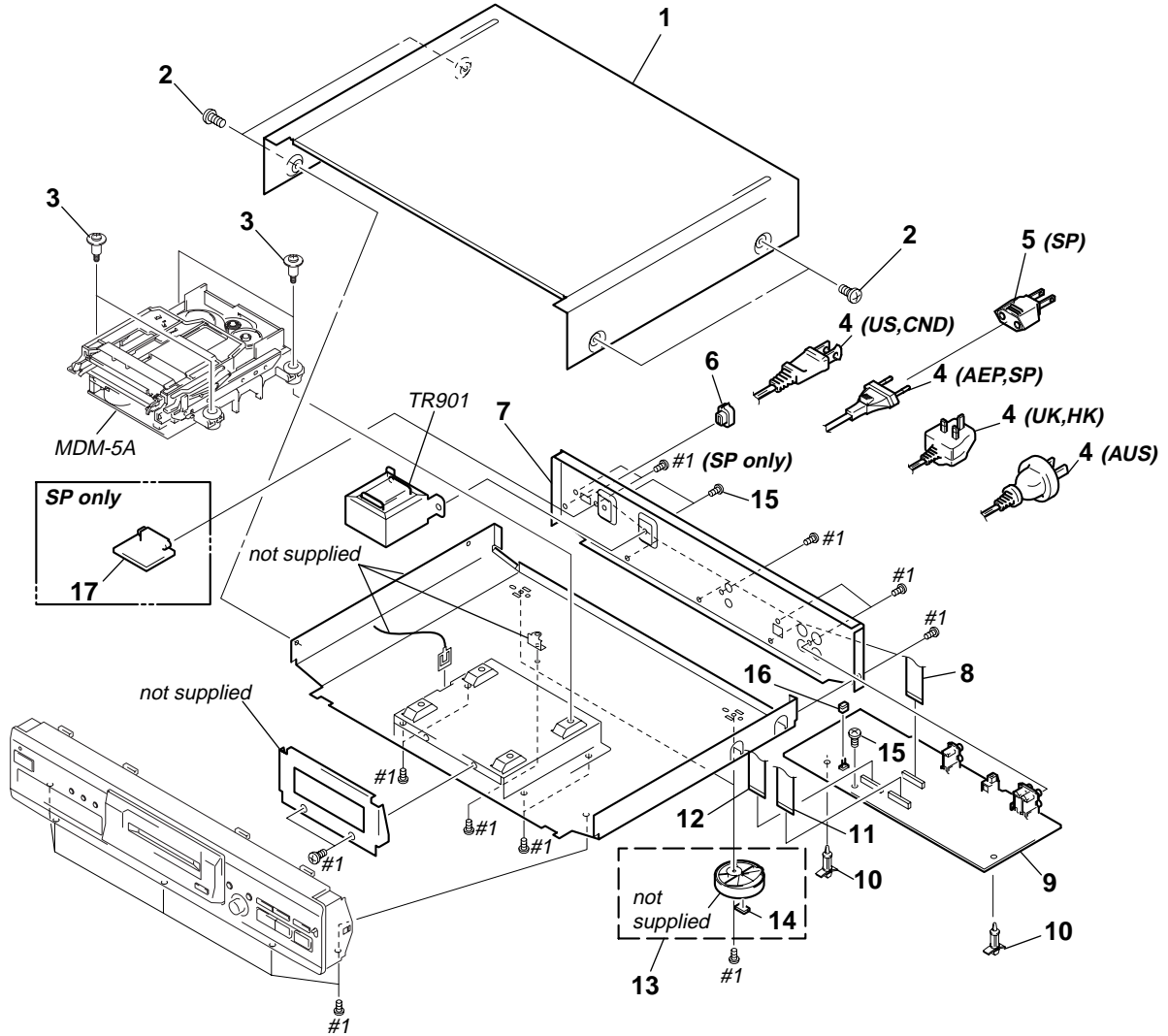

Ref. No.	Part No.	Description	Remark	Ref. No.	Part No.	Description	Remark
1	4-983-661-01	CASE (408226)		8	1-790-509-11	WIRE (FLAT TYPE) (17 CORE)	
2	4-210-291-01	SCREW (CASE 3 TP2)		* 9	A-4724-608-A	MAIN BOARD, COMPLETE (US,CND)	
3	4-999-839-11	SCREW (+BVTTWH M3), STEP		* 9	A-4724-611-A	MAIN BOARD, COMPLETE (AEP,UK,HK,AUS)	
\triangle 4	1-696-586-21	CORD, POWER (UK,HK)		* 9	A-4724-614-A	MAIN BOARD, COMPLETE (SP)	
\triangle 4	1-696-846-21	CORD, POWER (AUS)		* 10	4-954-051-51	HOLDER, PC BOARD	
\triangle 4	1-751-275-11	CORD, POWER (AEP,SP)		11	1-783-140-11	WIRE (FLAT TYPE) (23 CORE)	
\triangle 4	1-783-531-31	CORD, POWER (US,CND)		12	1-783-139-11	WIRE (FLAT TYPE) (21 CORE)	
5	1-569-008-21	ADAPTOR, CONVERSION 2P (SP)		13	X-4947-207-1	FOOT ASSY (F50150S)(AEP,UK,SP,HK,AUS)	
* 6	3-703-244-00	BUSHING (2104), CORD		13	X-4947-208-1	FOOT ASSY (F50150S)(US,CND)	
* 7	4-216-349-02	PANEL, BACK (US)		14	4-977-358-11	CUSHION (US,CND)	
* 7	4-216-349-12	PANEL, BACK (CND)		15	4-886-821-11	SCREW, S TIGHT, +PTTWH 3X6	
* 7	4-216-349-22	PANEL, BACK (AEP,UK)		16	1-569-972-21	SOCKET, SHORT 2P	
* 7	4-216-349-32	PANEL, BACK (AUS)		* 17	1-672-977-11	VOL SEL BOARD (SP)	
* 7	4-216-349-42	PANEL, BACK (SP)		\triangle TR901	1-433-693-11	TRANSFORMER, POWER (US,CND)	
* 7	4-216-349-52	PANEL, BACK (HK)		\triangle TR901	1-433-694-11	TRANSFORMER, POWER (AEP,UK,HK,AUS)	
				\triangle TR901	1-433-695-11	TRANSFORMER, POWER (SP)	

7-2. FRONT PANEL SECTION

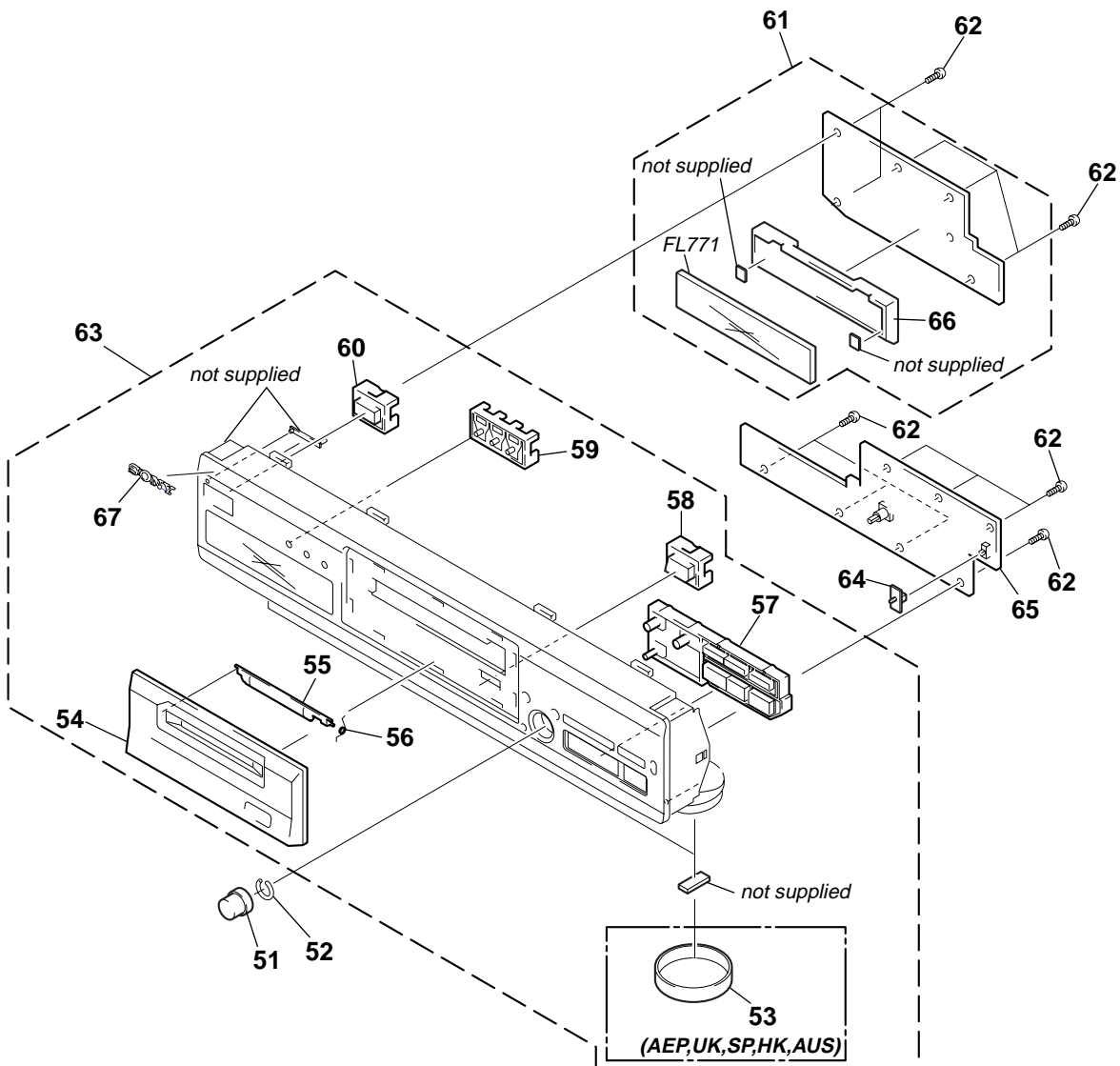

Ref. No.	Part No.	Description	Remark	Ref. No.	Part No.	Description	Remark
51	4-996-687-51	KNOB (AMS)		* 61	A-4724-613-A	DISPLAY BOARD, COMPLETE (AEP,UK,HK,AUS)	
52	3-354-981-11	SPRING (SUS), RING		* 61	A-4724-616-A	DISPLAY BOARD, COMPLETE (SP)	
53	4-977-593-11	RING (DIA. 50), ORNAMENTAL (AEP,UK,SP,HK,AUS)		62	4-951-620-01	SCREW (2.6X8), +BVTP	
54	4-216-342-01	ESCUTCHEON		63	X-4951-023-1	PANEL ASSY, FRONT (US,CND)	
55	4-996-690-12	LID (CARTRIDGE)		63	X-4951-024-1	PANEL ASSY, FRONT (AEP,UK,SP,HK,AUS)	
56	4-976-593-11	SPRING (LID), TORSION		64	4-998-595-01	KNOB (SLIDE)	
57	4-216-343-01	BUTTON (FUNCTION)		* 65	A-4724-609-A	KEY SW BOARD, COMPLETE (US,CND)	
58	4-216-346-01	BUTTON (EJECT)		* 65	A-4724-612-A	KEY SW BOARD, COMPLETE (AEP,UK,HK,AUS)	
59	4-216-345-01	BUTTON (SUB)		* 65	A-4724-615-A	KEY SW BOARD, COMPLETE (SP)	
60	4-216-344-01	BUTTON (POWER)		* 66	4-216-341-01	HOLDER (FL)	
* 61	A-4724-610-A	DISPLAY BOARD, COMPLETE (US,CND)		67	4-996-698-01	EMBLEM, SONY	
				FL771	1-517-865-11	INDICATOR TUBE, FLUORESCENT	

7-3. MECHANISM SECTION (MDM-5A)

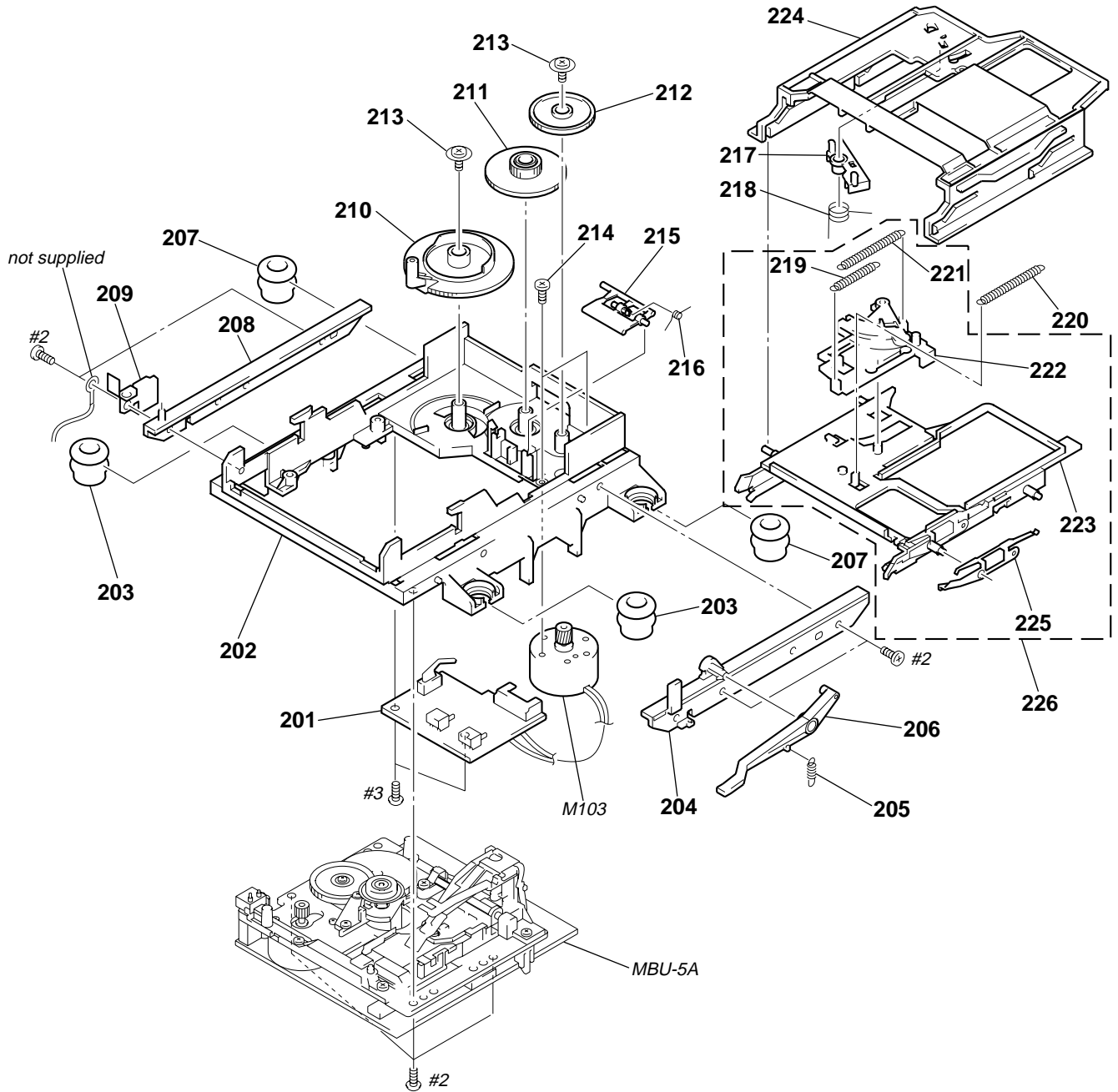

Ref. No.	Part No.	Description	Remark	Ref. No.	Part No.	Description	Remark
* 201	1-671-115-21	SW BOARD		215	4-996-227-01	LEVER (HEAD)	
* 202	4-996-217-01	CHASSIS		216	4-996-229-01	SPRING (HEAD LEVER), TORSION	
203	4-996-223-11	INSULATOR (F)		217	4-996-212-01	LEVER (LIMITTER)	
* 204	4-996-218-01	BRACKET (GUIDE R)		218	4-996-213-01	SPRING (LIMITTER), TORSION	
205	4-996-277-01	SPRING (O/C), TENSION		219	4-996-214-01	SPRING (SLIDER), TENSION	
206	4-996-226-01	LEVER (O/C)		220	4-966-216-01	SPRING (HOLDER), TENSION	
207	4-999-347-01	INSULATOR (R)		221	4-996-215-11	SPRING (LOCK LEVER), TENSION	
* 208	4-996-225-01	BRACKET (GUIDE L)		222	X-4949-246-1	SLIDER ASSY	
209	4-988-466-11	SPRING (ELECTROSTATIC), LEAF		223	X-4949-245-1	HOLDER ASSY	
210	4-996-219-01	GEAR (CAM GEAR)		* 224	4-996-211-11	SLIDER (CAM)	
211	4-996-220-01	GEAR (A)		225	4-998-763-01	SPRING (SHUTTER), LEAF	
212	4-996-221-01	GEAR (B)		226	A-4680-409-A	HOLDER	
213	4-933-134-01	SCREW (+PTPWH M2.6X6)		M103	X-4949-264-1	MOTOR ASSY, LOADING	
214	4-996-224-01	SCREW (1.7X3), +PWH					

7-4. BASE UNIT SECTION (MBU-5A)

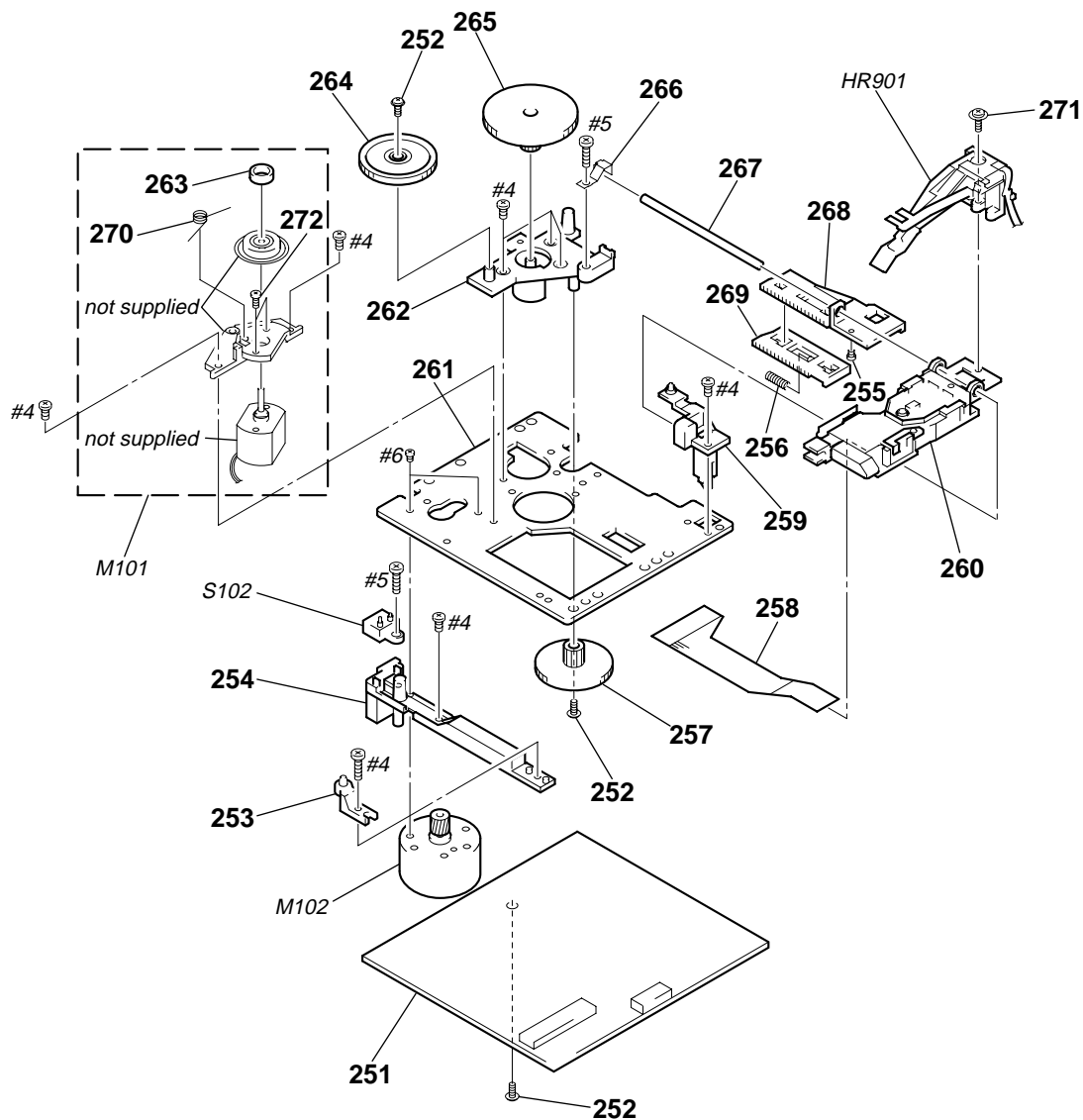

The components identified by mark \triangle or dotted line with mark \triangle are critical for safety. Replace only with part number specified.

Les composants identifiés par une marque \triangle sont critiques pour la sécurité. Ne les remplacer que par une pièce portant le numéro spécifié.

Ref. No.	Part No.	Description	Remark	Ref. No.	Part No.	Description	Remark
251	A-4699-893-A	BD BOARD, COMPLETE		264	4-996-260-01	GEAR (SL-A)	
252	3-372-761-01	SCREW (M1.7), TAPPING		265	4-996-261-01	GEAR (SL-B)	
* 253	4-996-267-01	BASE (BU-D)		266	4-996-264-01	SPRING (SHAFT), LEAF	
* 254	4-996-255-01	BASE (BU-C)		267	4-996-265-01	SHAFT, MAIN	
255	4-900-590-01	SCREW, PRECISION SMALL		268	4-996-256-11	SL (BASE)	
256	4-996-258-01	SPRING, COMPRESSION		269	4-996-257-01	RACK (SL)	
257	4-996-262-01	GEAR (SL-C)		270	4-996-263-01	SPRING (CLV), TORSION	
* 258	1-667-954-11	FLEXIBLE BOARD		271	4-988-560-01	SCREW (+P 1.7X6)	
* 259	4-210-664-11	BASE (BU-A)		272	4-211-036-01	SCREW (1.7X2.5), +PWH	
\triangle 260	8-583-028-01	OPTICAL PICK-UP KMS-260A/K1NP		HR901	1-500-502-11	HEAD, OVER WRITE	
* 261	4-996-252-01	CHASSIS, BU		M101	A-4672-475-A	MOTOR ASSY, SPINDLE	
* 262	4-996-254-01	BASE (BU-B)		M102	A-4672-474-A	MOTOR ASSY, SLED	
263	4-967-688-11	MAGNET, ABSORPTION		S102	1-762-148-21	SWITCH, PUSH (2 KEY)	

SECTION 8 ELECTRICAL PARTS LIST

BD

Note:

The components identified by mark Δ or dotted line with mark Δ are critical for safety. Replace only with part number specified.

Les composants identifiés par une marque Δ sont critiques pour la sécurité. Ne les remplacer que par une pièce portant le numéro spécifié.

When indicating parts by reference number, please include the board name.

- Due to standardization, replacements in the parts list may be different from the parts specified in the diagrams or the components used on the set.
- -XX, -X mean standardized parts, so they may have some difference from the original one.
- Items marked "*" are not stocked since they are seldom required for routine service. Some delay should be anticipated when ordering these items.
- RESISTORS
All resistors are in ohms
METAL: Metal-film resistor
METAL OXIDE: Metal Oxide-film resistor
F : nonflammable

- SEMICONDUCTORS
In each case, u: μ , for example:
uA...: μ A..., uPA...: μ PA..., uPB...: μ PB...,
uPC...: μ PC..., uPD...: μ PD...
- CAPACITORS
uF : μ F
- COILS
uH : μ H
- Abbreviation
CND : Canadian model
HK : Hong Kong model
SP : Singapore model
AUS : Australian model

Ref. No.	Part No.	Description	Remark	Ref. No.	Part No.	Description	Remark
	A-4699-893-A	BD BOARD, COMPLETE *****		C163	1-163-021-91	CERAMIC CHIP 0.01uF	10% 50V
		< CAPACITOR >		C164	1-163-021-91	CERAMIC CHIP 0.01uF	10% 50V
				C167	1-163-038-91	CERAMIC CHIP 0.1uF	25V
C101	1-125-822-11	TANTALUM 10uF	20% 10V	C168	1-163-038-91	CERAMIC CHIP 0.1uF	25V
C102	1-163-038-91	CERAMIC CHIP 0.1uF	25V	C169	1-125-822-11	TANTALUM 10uF	20% 10V
C103	1-125-822-11	TANTALUM 10uF	20% 10V	C171	1-163-038-91	CERAMIC CHIP 0.1uF	25V
C104	1-125-822-11	TANTALUM 10uF	20% 10V	C181	1-104-913-11	TANTAL. CHIP 10uF	20% 16V
C105	1-163-021-91	CERAMIC CHIP 0.01uF	10% 50V	C183	1-163-038-91	CERAMIC CHIP 0.1uF	25V
C106	1-163-275-11	CERAMIC CHIP 0.001uF	5% 50V	C184	1-117-970-11	ELECT CHIP 22uF	20% 10V
C107	1-163-038-91	CERAMIC CHIP 0.1uF	25V	C185	1-164-611-11	CERAMIC CHIP 0.001uF	10% 500V
C108	1-163-038-91	CERAMIC CHIP 0.1uF	25V	C187	1-104-913-11	TANTAL. CHIP 10uF	20% 16V
C109	1-163-037-11	CERAMIC CHIP 0.022uF	10% 25V	C188	1-163-021-91	CERAMIC CHIP 0.01uF	10% 50V
C111	1-164-344-11	CERAMIC CHIP 0.068uF	10% 25V	C189	1-163-989-11	CERAMIC CHIP 0.033uF	10% 25V
C112	1-163-017-00	CERAMIC CHIP 0.0047uF	5% 50V	C190	1-126-206-11	ELECT CHIP 100uF	20% 6.3V
C113	1-109-982-11	CERAMIC CHIP 1uF	10% 10V	C191	1-163-038-91	CERAMIC CHIP 0.1uF	25V
C115	1-164-489-11	CERAMIC CHIP 0.22uF	10% 16V	C196	1-163-038-91	CERAMIC CHIP 0.1uF	25V
C116	1-163-037-11	CERAMIC CHIP 0.022uF	10% 25V	C197	1-163-038-91	CERAMIC CHIP 0.1uF	25V
C117	1-163-809-11	CERAMIC CHIP 0.047uF	10% 25V			< CONNECTOR >	
C118	1-163-038-91	CERAMIC CHIP 0.1uF	25V	CN101	1-569-479-21	CONNECTOR, FPC 21P	
C119	1-125-822-11	TANTALUM 10uF	20% 10V	CN102	1-784-833-21	CONNECTOR, FFC(LIF(NON-ZIF))21P	
C121	1-125-822-11	TANTALUM 10uF	20% 10V	CN103	1-784-834-21	CONNECTOR, FFC(LIF(NON-ZIF))23P	
C122	1-163-021-91	CERAMIC CHIP 0.01uF	10% 50V	CN104	1-770-687-11	CONNECTOR, FFC/FPC 4P	
C123	1-163-038-91	CERAMIC CHIP 0.1uF	25V	CN110	1-695-440-21	PIN, CONNECTOR (PC BOARD) 6P	
C124	1-163-038-91	CERAMIC CHIP 0.1uF	25V			< DIODE >	
C127	1-163-038-91	CERAMIC CHIP 0.1uF	25V	D101	8-719-988-61	DIODE 1SS355TE-17	
C128	1-163-021-91	CERAMIC CHIP 0.01uF	10% 50V	D181	8-719-046-86	DIODE F1J6TP	
C129	1-107-823-11	CERAMIC CHIP 0.47uF	10% 16V	D183	8-719-046-86	DIODE F1J6TP	
C130	1-163-251-11	CERAMIC CHIP 100PF	5% 50V			< IC >	
C131	1-163-023-00	CERAMIC CHIP 0.015uF	5% 50V	IC101	8-752-080-95	IC CXA2523AR	
C132	1-107-823-11	CERAMIC CHIP 0.47uF	10% 16V	IC103	8-729-903-10	IC TRANSISTOR FMW1	
C133	1-163-017-00	CERAMIC CHIP 0.0047uF	5% 50V	IC121	8-752-389-44	IC CXD2654R	
C134	1-163-038-91	CERAMIC CHIP 0.1uF	25V	IC123	8-759-096-87	IC TC7WU04FU(TE12R)	
C135	1-163-038-91	CERAMIC CHIP 0.1uF	25V	IC124	8-759-498-44	IC MSM51V4400-70TS-K	
C136	1-126-206-11	ELECT CHIP 100uF	20% 6.3V	IC152	8-759-430-25	IC BH6511FS-E2	
C142	1-163-251-11	CERAMIC CHIP 100PF	5% 50V	IC171	8-759-487-04	IC BR24C02F-E2	
C143	1-163-251-11	CERAMIC CHIP 100PF	5% 50V	IC181	8-759-481-17	IC MC74ACT08DTR2	
C144	1-163-251-11	CERAMIC CHIP 100PF	5% 50V	IC192	8-759-460-72	IC BA033FP-E2	
C146	1-163-038-91	CERAMIC CHIP 0.1uF	25V			< COIL >	
C151	1-126-206-11	ELECT CHIP 100uF	20% 6.3V	L101	1-414-813-11	FERRITE 0uH	
C152	1-163-038-91	CERAMIC CHIP 0.1uF	25V	L102	1-414-813-11	FERRITE 0uH	
C153	1-163-021-91	CERAMIC CHIP 0.01uF	10% 50V	L103	1-414-813-11	FERRITE 0uH	
C156	1-163-038-91	CERAMIC CHIP 0.1uF	25V	L105	1-414-813-11	FERRITE 0uH	
C158	1-163-019-00	CERAMIC CHIP 0.0068uF	10% 50V	L106	1-414-813-11	FERRITE 0uH	
C160	1-104-601-11	ELECT CHIP 10uF	20% 10V				
C161	1-104-601-11	ELECT CHIP 10uF	20% 10V				

Ref. No.	Part No.	Description	Remark	Ref. No.	Part No.	Description	Remark				
L121	1-414-813-11	FERRITE	0uH	R151	1-216-073-00	METAL CHIP	10K 5% 1/10W				
L122	1-414-813-11	FERRITE	0uH	R152	1-216-073-00	METAL CHIP	10K 5% 1/10W				
L151	1-412-029-11	INDUCTOR CHIP	10uH	R158	1-216-097-91	RES,CHIP	100K 5% 1/10W				
L152	1-412-029-11	INDUCTOR CHIP	10uH	R159	1-216-097-91	RES,CHIP	100K 5% 1/10W				
L153	1-412-032-11	INDUCTOR CHIP	100uH	R160	1-216-295-91	SHORT	0				
L154	1-412-032-11	INDUCTOR CHIP	100uH	R161	1-216-057-00	METAL CHIP	2.2K 5% 1/10W				
L161	1-414-813-11	FERRITE	0uH	R162	1-216-057-00	METAL CHIP	2.2K 5% 1/10W				
L162	1-414-813-11	FERRITE	0uH	R163	1-216-057-00	METAL CHIP	2.2K 5% 1/10W				
L181	1-216-295-91	SHORT	0	R164	1-216-045-00	METAL CHIP	680 5% 1/10W				
< TRANSISTOR >				R165	1-216-097-91	RES,CHIP	100K 5% 1/10W				
Q101	8-729-403-35	TRANSISTOR	UN5113	R166	1-220-149-11	REGISTER	2.2 10% 1/2W				
Q102	8-729-026-53	TRANSISTOR	2SA1576A-T106-QR	R167	1-216-065-91	RES,CHIP	4.7K 5% 1/10W				
Q103	8-729-402-93	TRANSISTOR	UN5214	R169	1-219-724-11	METAL CHIP	1 1% 1/4W				
Q104	8-729-402-93	TRANSISTOR	UN5214	R170	1-216-073-00	METAL CHIP	10K 5% 1/10W				
Q162	8-729-101-07	TRANSISTOR	2SB798-DL	R171	1-216-073-00	METAL CHIP	10K 5% 1/10W				
Q163	8-729-403-35	TRANSISTOR	UN5113	R173	1-216-121-91	RES,CHIP	1M 5% 1/10W				
Q181	8-729-018-75	TRANSISTOR	2SJ278MY	R175	1-216-065-91	RES,CHIP	4.7K 5% 1/10W				
Q182	8-729-017-65	TRANSISTOR	2SK1764KY	R177	1-216-061-00	METAL CHIP	3.3K 5% 1/10W				
< RESISTOR >				R179	1-216-085-00	METAL CHIP	33K 5% 1/10W				
R103	1-216-049-91	RES,CHIP	1K	5%	1/10W	R180	1-216-073-00	METAL CHIP	10K 5% 1/10W		
R104	1-216-073-00	METAL CHIP	10K	5%	1/10W	R182	1-216-089-91	RES,CHIP	47K 5% 1/10W		
R105	1-216-065-91	RES,CHIP	4.7K	5%	1/10W	R183	1-216-089-91	RES,CHIP	47K 5% 1/10W		
R106	1-216-133-00	METAL CHIP	3.3M	5%	1/10W	R184	1-216-073-00	METAL CHIP	10K 5% 1/10W		
R107	1-216-113-00	METAL CHIP	470K	5%	1/10W	R185	1-216-081-00	METAL CHIP	22K 5% 1/10W		
R109	1-216-295-91	SHORT	0	R186	1-216-089-91	RES,CHIP	47K 5% 1/10W				
R110	1-216-073-00	METAL CHIP	10K	5%	1/10W	R188	1-216-073-00	METAL CHIP	10K 5% 1/10W		
R111	1-216-295-91	SHORT	0	R189	1-216-073-00	METAL CHIP	10K 5% 1/10W				
R112	1-216-089-91	RES,CHIP	47K	5%	1/10W	R190	1-216-073-00	METAL CHIP	10K 5% 1/10W		
R113	1-216-049-91	RES,CHIP	1K	5%	1/10W	R195	1-216-073-00	METAL CHIP	10K 5% 1/10W		
R115	1-216-049-91	RES,CHIP	1K	5%	1/10W	R196	1-216-295-91	SHORT	0		
R117	1-216-113-00	METAL CHIP	470K	5%	1/10W	R197	1-216-295-91	SHORT	0		
R120	1-216-025-91	RES,CHIP	100	5%	1/10W	< SWITCH >					
R121	1-216-097-91	RES,CHIP	100K	5%	1/10W	S101	1-762-596-21	SWITCH, PUSH (1 KEY)(LIMIT IN)			
R123	1-216-295-91	SHORT	0	*****							
R124	1-216-025-91	RES,CHIP	100	5%	1/10W	*	A-4724-610-A	DISPLAY BOARD, COMPLETE (US,CND)			
R125	1-216-025-91	RES,CHIP	100	5%	1/10W	*****					
R127	1-216-025-91	RES,CHIP	100	5%	1/10W	*	A-4724-616-A	DISPLAY BOARD, COMPLETE (SP)			
R129	1-216-295-91	SHORT	0	*****							
R131	1-216-073-00	METAL CHIP	10K	5%	1/10W	*	A-4724-613-A	DISPLAY BOARD, COMPLETE (AEP,UK,HK,AUS)			
R132	1-216-097-91	RES,CHIP	100K	5%	1/10W	*****					
R133	1-216-117-00	METAL CHIP	680K	5%	1/10W	*	4-216-341-01	HOLDER (FL)			
R134	1-216-049-91	RES,CHIP	1K	5%	1/10W	*****					
R135	1-216-061-00	METAL CHIP	3.3K	5%	1/10W	< CAPACITOR >					
R136	1-216-049-91	RES,CHIP	1K	5%	1/10W	C760	1-164-159-11	CERAMIC	0.1uF	50V	
R137	1-216-295-91	SHORT	0	C761	1-162-294-31	CERAMIC	0.001uF	10%	50V		
R140	1-216-029-00	METAL CHIP	150	5%	1/10W	C762	1-162-294-31	CERAMIC	0.001uF	10%	50V
R142	1-216-073-00	METAL CHIP	10K	5%	1/10W	C763	1-162-294-31	CERAMIC	0.001uF	10%	50V
R143	1-216-073-00	METAL CHIP	10K	5%	1/10W	C764	1-164-159-11	CERAMIC	0.1uF	50V	
R144	1-216-025-91	RES,CHIP	100	5%	1/10W	C765	1-126-153-11	ELECT	22uF	20%	6.3V
R145	1-216-073-00	METAL CHIP	10K	5%	1/10W	C766	1-164-159-11	CERAMIC	0.1uF	50V	
R146	1-216-037-00	METAL CHIP	330	5%	1/10W	C769	1-162-215-31	CERAMIC	47PF	5%	50V
R147	1-216-025-91	RES,CHIP	100	5%	1/10W	C781	1-124-584-00	ELECT	100uF	20%	10V
R148	1-216-045-00	METAL CHIP	680	5%	1/10W	C782	1-162-306-11	CERAMIC	0.01uF	20%	16V
R149	1-216-073-00	METAL CHIP	10K	5%	1/10W						
R150	1-216-295-91	SHORT	0								

DISPLAY

KEY SW

MAIN

Ref. No.	Part No.	Description	Remark
		< CONNECTOR >	
CN751	1-784-642-11	CONNECTOR, BOARD TO BOARD 11P	
		< DIODE >	
D751	8-719-046-44	DIODE SEL5221S (STANDBY)	
		< FLUORESCENT INDICATOR >	
FL771	1-517-865-11	INDICATOR TUBE, FLUORESCENT	
		< IC >	
IC761	8-759-426-98	IC MSM9202-02GS-K	
IC781	8-749-013-92	IC GP1UC7X	
		< TRANSISTOR >	
Q751	8-729-422-57	TRANSISTOR UN4111	
Q767	8-729-900-74	TRANSISTOR DTC143TS	
		< RESISTOR >	
R722	1-249-421-11	CARBON 2.2K 5% 1/4W F	
R723	1-247-843-11	CARBON 3.3K 5% 1/4W	
R724	1-249-425-11	CARBON 4.7K 5% 1/4W F	
R725	1-249-429-11	CARBON 10K 5% 1/4W	
R726	1-249-435-11	CARBON 33K 5% 1/4W	
R751	1-249-409-11	CARBON 220 5% 1/4W F	
R760	1-247-807-31	CARBON 100 5% 1/4W	
R761	1-247-807-31	CARBON 100 5% 1/4W	
R762	1-247-807-31	CARBON 100 5% 1/4W	
R763	1-247-807-31	CARBON 100 5% 1/4W	
R767	1-249-441-11	CARBON 100K 5% 1/4W	
R769	1-247-843-11	CARBON 3.3K 5% 1/4W	
R781	1-249-401-11	CARBON 47 5% 1/4W F	
R782	1-247-807-31	CARBON 100 5% 1/4W	
		< SWITCH >	
S722	1-762-875-21	SWITCH, KEYBOARD (PLAY MODE)	
S723	1-762-875-21	SWITCH, KEYBOARD (REPEAT)	
S725	1-762-875-21	SWITCH, KEYBOARD (LEVEL/DISPLAY/CHAR)	
S726	1-762-875-21	SWITCH, KEYBOARD (I/⏏)	
		< CAPACITOR >	
C700	1-126-153-11	ELECT 22uF 20% 6.3V	
		< CONNECTOR >	
CN701	1-779-554-11	CONNECTOR,FFC(LIF(NON-ZIF))17P	
CN731	1-784-641-11	CONNECTOR, BOARD TO BOARD 11P	

Ref. No.	Part No.	Description	Remark
		< RESISTOR >	
R702	1-249-421-11	CARBON 2.2K 5% 1/4W F	
R703	1-247-843-11	CARBON 3.3K 5% 1/4W	
R704	1-249-425-11	CARBON 4.7K 5% 1/4W F	
R705	1-249-429-11	CARBON 10K 5% 1/4W	
R706	1-249-435-11	CARBON 33K 5% 1/4W	
R712	1-249-421-11	CARBON 2.2K 5% 1/4W F	
R713	1-247-843-11	CARBON 3.3K 5% 1/4W	
R714	1-249-425-11	CARBON 4.7K 5% 1/4W F	
		< SWITCH >	
S701	1-762-875-21	SWITCH, KEYBOARD (●)	
S702	1-762-875-21	SWITCH, KEYBOARD (■)	
S703	1-762-875-21	SWITCH, KEYBOARD (▶▶)	
S704	1-762-875-21	SWITCH, KEYBOARD (◀◀)	
S705	1-762-875-21	SWITCH, KEYBOARD (■)	
S706	1-762-875-21	SWITCH, KEYBOARD (▷)	
S711	1-762-875-21	SWITCH, KEYBOARD (MENU/NO)	
S712	1-762-875-21	SWITCH, KEYBOARD (YES)	
S713	1-475-543-11	ENCODER, ROTARY (PUSH ENTER/I◀◀ AMS ▷▶I)	
S714	1-762-875-21	SWITCH, KEYBOARD (CLEAR)	
S721	1-762-875-21	SWITCH, KEYBOARD (⊕)	
S731	1-762-404-11	SWITCH, SLIDE (INPUT DIGITAL/ANALOG)	

*	A-4724-608-A	MAIN BOARD, COMPLETE (US,CND) *****	
*	A-4724-611-A	MAIN BOARD, COMPLETE (AEP,UK,HK,AUS) *****	
*	A-4724-614-A	MAIN BOARD, COMPLETE (SP) *****	
	7-685-872-09	SCREW +BVTT 3X8 (S)	
		< BATTERY >	
BT406	1-528-887-11	BATTERY, LITHIUM SECONDARY	
		< CAPACITOR >	
C101	1-162-290-31	CERAMIC 470PF 10% 50V	
C102	1-126-964-11	ELECT 10uF 20% 50V	
C181	1-128-551-11	ELECT 22uF 20% 25V	
C182	1-162-600-11	CERAMIC 0.0047uF 30% 16V	
C183	1-162-294-31	CERAMIC 0.001uF 10% 50V	
C184	1-126-963-11	ELECT 4.7uF 20% 50V	
C185	1-162-282-31	CERAMIC 100PF 10% 50V	
C201	1-162-290-31	CERAMIC 470PF 10% 50V	
C202	1-126-964-11	ELECT 10uF 20% 50V	
C281	1-128-551-11	ELECT 22uF 20% 25V	
C282	1-162-600-11	CERAMIC 0.0047uF 30% 16V	
C283	1-162-294-31	CERAMIC 0.001uF 10% 50V	
C284	1-126-963-11	ELECT 4.7uF 20% 50V	
C285	1-162-282-31	CERAMIC 100PF 10% 50V	
C300	1-126-934-11	ELECT 220uF 20% 10V	
C301	1-164-159-11	CERAMIC 0.1uF 50V	

MAIN

Ref. No.	Part No.	Description			Remark	Ref. No.	Part No.	Description			Remark
C302	1-126-934-11	ELECT	220uF	20%	10V	C901	1-113-920-11	CERAMIC	0.0022uF	20%	250V
C303	1-164-159-11	CERAMIC	0.1uF		50V	C902	1-113-920-11	CERAMIC	0.0022uF	20%	250V
C304	1-164-159-11	CERAMIC	0.1uF		50V						
C305	1-164-159-11	CERAMIC	0.1uF		50V	C911	1-164-159-11	CERAMIC	0.1uF		50V
C306	1-126-934-11	ELECT	220uF	20%	10V	C912	1-164-159-11	CERAMIC	0.1uF		50V
C307	1-164-159-11	CERAMIC	0.1uF		50V	C913	1-164-159-11	CERAMIC	0.1uF		50V
C308	1-126-934-11	ELECT	220uF	20%	10V	< CONNECTOR >					
C350	1-164-159-11	CERAMIC	0.1uF		50V	CN406	1-568-683-11	PIN, CONNECTOR (PC BAORD)	2P		
C351	1-162-205-31	CERAMIC	18PF	5%	50V	CN411	1-784-418-11	CONNECTOR, FFC(LIF(NON-ZIF))	21P		
C352	1-162-203-31	CERAMIC	15PF	5%	50V	CN421	1-779-285-11	CONNECTOR, FFC(LIF(NON-ZIF))	17P		
C370	1-126-933-11	ELECT	100uF	20%	16V	CN501	1-784-417-11	CONNECTOR, FFC(LIF(NON-ZIF))	23P		
C371	1-126-934-11	ELECT	220uF	20%	16V	* CN502	1-568-934-11	PIN, CONNECTOR	7P		
C380	1-164-159-11	CERAMIC	0.1uF		50V						
C381	1-164-159-11	CERAMIC	0.1uF		50V	CN881	1-506-468-11	PIN, CONNECTOR	3P		
C385	1-164-159-11	CERAMIC	0.1uF		50V	* CN882	1-568-954-11	PIN, CONNECTOR	5P		
C386	1-164-159-11	CERAMIC	0.1uF		50V	* CN901	1-580-230-11	PIN, CONNECTOR (PC BOARD)	2P		
C401	1-126-936-11	ELECT	3300uF	20%	16V	< DIODE >					
C402	1-164-159-11	CERAMIC	0.1uF		50V	D390	8-719-911-19	DIODE	1SS119-25		
C404	1-126-933-11	ELECT	100uF	20%	16V	D391	8-719-911-19	DIODE	1SS119-25		
C406	1-124-252-00	ELECT	0.33uF	20%	50V	D401	8-719-210-21	DIODE	11EQS04		
C407	1-162-294-31	CERAMIC	0.001uF	10%	50V	D402	8-719-210-21	DIODE	11EQS04		
C411	1-126-939-11	ELECT	10000uF	20%	16V	D403	8-719-210-21	DIODE	11EQS04		
C412	1-164-159-11	CERAMIC	0.1uF		50V	D404	8-719-210-21	DIODE	11EQS04		
C416	1-126-926-11	ELECT	1000uF	20%	10V	D406	8-719-911-19	DIODE	1SS119-25		
C421	1-164-159-11	CERAMIC	0.1uF		50V	D408	8-719-210-21	DIODE	11EQS04		
C422	1-164-159-11	CERAMIC	0.1uF		50V	D409	8-719-210-21	DIODE	11EQS04		
C423	1-128-576-11	ELECT	100uF	20%	63V	D411	8-719-024-99	DIODE	11ES2-NTA2B		
C424	1-164-159-11	CERAMIC	0.1uF		50V	D412	8-719-024-99	DIODE	11ES2-NTA2B		
C425	1-126-967-11	ELECT	47uF	20%	50V	D421	8-719-024-99	DIODE	11ES2-NTA2B		
C426	1-126-965-11	ELECT	22uF	20%	50V	D422	8-719-109-81	DIODE	RD4.7ESB2		
C431	1-126-966-11	ELECT	33uF	20%	16V	D431	8-719-911-19	DIODE	1SS119-25		
C432	1-128-551-11	ELECT	22uF	20%	25V	D432	8-719-911-19	DIODE	1SS119-25		
C441	1-126-933-11	ELECT	100uF	20%	16V	D433	8-719-911-19	DIODE	1SS119-25		
C442	1-162-306-11	CERAMIC	0.01uF	20%	16V	D461	8-719-024-99	DIODE	11ES2-NTA2B		
C443	1-162-306-11	CERAMIC	0.01uF	20%	16V	D462	8-719-024-99	DIODE	11ES2-NTA2B		
C461	1-126-935-11	ELECT	470uF	20%	16V	D466	8-719-024-99	DIODE	11ES2-NTA2B		
C466	1-126-935-11	ELECT	470uF	20%	16V	D467	8-719-024-99	DIODE	11ES2-NTA2B		
C500	1-131-347-00	TANTALUM	1uF	10%	35V	D911	8-719-911-19	DIODE	1SS119-25		
C512	1-164-159-11	CERAMIC	0.1uF		50V	< IC >					
C516	1-164-159-11	CERAMIC	0.1uF		50V	IC301	8-759-553-65	IC	UDA1341TS/N2		
C519	1-162-294-31	CERAMIC	0.001uF	10%	50V	IC351	8-759-917-18	IC	SN74HCU04AN		
C531	1-162-282-31	CERAMIC	100PF	10%	50V	IC381	8-759-634-50	IC	M5218AL		
C533	1-162-282-31	CERAMIC	100PF	10%	50V	IC386	8-759-634-50	IC	M5218AL		
C562	1-164-159-11	CERAMIC	0.1uF		50V	IC401	8-759-445-59	IC	BA033T		
C571	1-162-282-31	CERAMIC	100PF	10%	50V	IC406	8-759-481-02	IC	M62016L		
C572	1-162-282-31	CERAMIC	100PF	10%	50V	IC411	8-759-231-53	IC	TA7805S		
C573	1-162-282-31	CERAMIC	100PF	10%	50V	IC421	8-759-633-42	IC	M5293L		
C575	1-162-282-31	CERAMIC	100PF	10%	50V	IC441	8-759-822-09	IC	LB1641		
C594	1-162-294-31	CERAMIC	0.001uF	10%	50V	IC501	8-759-577-40	IC	M30620MC-400FP		
C595	1-162-294-31	CERAMIC	0.001uF	10%	50V	IC601	8-759-917-18	IC	SN74HCU04AN		
C597	1-162-294-31	CERAMIC	0.001uF	10%	50V	IC611	8-749-012-70	IC	GP1F38R (DIGITAL OPTICAL IN)		
C598	1-164-159-11	CERAMIC	0.1uF		50V	< JACK >					
C599	1-164-159-11	CERAMIC	0.1uF		50V	J101	1-784-429-11	JACK, PIN 4P (LINE (ANALOG) IN)			
C601	1-162-306-11	CERAMIC	0.01uF	20%	16V						
C611	1-164-159-11	CERAMIC	0.1uF		50V						
C612	1-126-963-11	ELECT	4.7uF	20%	50V						
C613	1-162-306-11	CERAMIC	0.01uF	20%	16V						

Ref. No.	Part No.	Description	Remark	Ref. No.	Part No.	Description	Remark
		< COIL >		R433	1-247-822-11	CARBON 430 5%	1/4W
L611	1-410-509-11	INDUCTOR 10uH		R434	1-249-433-11	CARBON 22K 5%	1/4W
		< LINE FILTER >		R435	1-249-438-11	CARBON 56K 5%	1/4W
				R436	1-247-891-00	CARBON 330K 5%	1/4W
LF901	1-411-547-11	FILTER, LINE		R437	1-249-417-11	CARBON 1K 5%	1/4W F
		< TRANSISTOR >		R441	1-249-431-11	CARBON 15K 5%	1/4W
Q191	8-729-900-74	TRANSISTOR DTC143TS		R442	1-249-433-11	CARBON 22K 5%	1/4W
Q291	8-729-900-74	TRANSISTOR DTC143TS		R443	1-249-434-11	CARBON 27K 5%	1/4W
Q390	8-729-422-57	TRANSISTOR UN4111		R509	1-249-441-11	CARBON 100K 5%	1/4W
Q441	8-729-900-80	TRANSISTOR DTC114ES		R513	1-247-903-00	CARBON 1M 5%	1/4W
Q442	8-729-119-76	TRANSISTOR 2SA1175-HEF		R519	1-249-429-11	CARBON 10K 5%	1/4W
Q911	8-729-119-78	TRANSISTOR 2SC2785-HEF		R530	1-249-429-11	CARBON 10K 5%	1/4W
		< RESISTOR >		R531	1-249-429-11	CARBON 10K 5%	1/4W
R81	1-249-441-11	CARBON 100K 5%	1/4W (US,CND)	R533	1-249-429-11	CARBON 10K 5%	1/4W
R82	1-249-441-11	CARBON 100K 5%	1/4W (AEP,UK,SP,HK,AUS)	R542	1-249-429-11	CARBON 10K 5%	1/4W
R101	1-249-417-11	CARBON 1K 5%	1/4W F	R543	1-249-429-11	CARBON 10K 5%	1/4W
R102	1-249-441-11	CARBON 100K 5%	1/4W	R550	1-249-429-11	CARBON 10K 5%	1/4W
R106	1-249-430-11	CARBON 12K 5%	1/4W	R551	1-249-429-11	CARBON 10K 5%	1/4W
R181	1-249-429-11	CARBON 10K 5%	1/4W	R553	1-249-429-11	CARBON 10K 5%	1/4W
R182	1-249-429-11	CARBON 10K 5%	1/4W	R559	1-249-429-11	CARBON 10K 5%	1/4W
R183	1-249-433-11	CARBON 22K 5%	1/4W	R560	1-249-429-11	CARBON 10K 5%	1/4W
R184	1-247-864-11	CARBON 24K 5%	1/4W	R566	1-249-441-11	CARBON 100K 5%	1/4W
R185	1-249-417-11	CARBON 1K 5%	1/4W F	R568	1-249-429-11	CARBON 10K 5%	1/4W
R186	1-249-417-11	CARBON 1K 5%	1/4W F	R569	1-249-429-11	CARBON 10K 5%	1/4W
R187	1-249-437-11	CARBON 47K 5%	1/4W	R571	1-249-441-11	CARBON 100K 5%	1/4W
R188	1-249-415-11	CARBON 680 5%	1/4W F	R573	1-249-429-11	CARBON 10K 5%	1/4W
R189	1-249-411-11	CARBON 330 5%	1/4W	R574	1-249-429-11	CARBON 10K 5%	1/4W
R201	1-249-417-11	CARBON 1K 5%	1/4W F	R575	1-249-429-11	CARBON 10K 5%	1/4W
R202	1-249-441-11	CARBON 100K 5%	1/4W	R577	1-249-429-11	CARBON 10K 5%	1/4W
R206	1-249-430-11	CARBON 12K 5%	1/4W	R581	1-249-441-11	CARBON 100K 5%	1/4W (AEP,UK,SP,HK,AUS)
R281	1-249-429-11	CARBON 10K 5%	1/4W	R582	1-249-441-11	CARBON 100K 5%	1/4W (US,CND)
R282	1-249-429-11	CARBON 10K 5%	1/4W	R587	1-249-441-11	CARBON 100K 5%	1/4W
R283	1-249-433-11	CARBON 22K 5%	1/4W	R592	1-249-429-11	CARBON 10K 5%	1/4W
R284	1-247-864-11	CARBON 24K 5%	1/4W	R594	1-249-429-11	CARBON 10K 5%	1/4W
R285	1-249-417-11	CARBON 1K 5%	1/4W F	R595	1-249-429-11	CARBON 10K 5%	1/4W
R286	1-249-417-11	CARBON 1K 5%	1/4W F	R597	1-249-429-11	CARBON 10K 5%	1/4W
R287	1-249-437-11	CARBON 47K 5%	1/4W	R613	1-247-895-00	CARBON 470K 5%	1/4W
R288	1-249-415-11	CARBON 680 5%	1/4W F	R614	1-249-437-11	CARBON 47K 5%	1/4W
R289	1-249-411-11	CARBON 330 5%	1/4W	R801	1-249-426-11	CARBON 5.6K 5%	1/4W
R351	1-247-903-00	CARBON 1M 5%	1/4W	R803	1-249-425-11	CARBON 4.7K 5%	1/4W F
R352	1-249-413-11	CARBON 470 5%	1/4W F	R804	1-249-429-11	CARBON 10K 5%	1/4W
R355	1-249-407-11	CARBON 150 5%	1/4W F			< RELAY >	
R391	1-249-441-11	CARBON 100K 5%	1/4W	RY911	1-755-324-11	RELAY	
R392	1-247-883-00	CARBON 150K 5%	1/4W			< TRANSFORMER >	
R406	1-249-409-11	CARBON 220 5%	1/4W F	TR901	1-433-702-11	TRANSFORMER, POWER (SUB)(US,CND)	
R407	1-249-429-11	CARBON 10K 5%	1/4W	TR901	1-433-703-11	TRANSFORMER, POWER (SUB)(AEP,UK,HK,AUS)	
R420	1-247-881-00	CARBON 120K 5%	1/4W	TR901	1-433-704-11	TRANSFORMER, POWER (SUB)(SP)	
R422	1-249-441-11	CARBON 100K 5%	1/4W	△ TR911	1-433-693-11	TRANSFORMER, POWER (US,CND)	
R423	1-249-409-11	CARBON 220 5%	1/4W F	△ TR911	1-433-694-11	TRANSFORMER, POWER (AEP,UK,HK,AUS)	
R424	1-249-409-11	CARBON 220 5%	1/4W F	△ TR911	1-433-695-11	TRANSFORMER, POWER (SP)	
R431	1-247-807-31	CARBON 100 5%	1/4W				
R432	1-247-826-00	CARBON 620 5%	1/4W				

MAIN **SW** **VOL SEL**

Ref. No.	Part No.	Description	Remark
		< VIBRATOR >	
X351	1-579-314-11	VIBRATOR, CRYSTAL (22.5792MHz)	
X513	1-781-174-21	VIBRATOR, CERAMIC (10MHz)	

*	1-671-115-21	SW BOARD *****	
		< CONNECTOR >	
CN601	1-506-486-11	PIN, CONNECTOR 7P	
		< SWITCH >	
S601	1-572-126-21	SWITCH, PUSH (1 KEY)(REC POSITION)	
S602	1-572-126-21	SWITCH, PUSH (1 KEY)(PACK OUT)	
S604	1-771-264-11	SWITCH, PUSH(DETECTION)(1 KEY) (PB POSITION)	

*	1-672-977-11	VOL SEL BOARD (SP) *****	
		< SWITCH >	
S951	1-771-474-11	SWITCH, POWER (VOLTAGE CHANGE)(SP)	

		MISCELLANEOUS *****	
△4	1-696-586-21	CORD, POWER (UK,HK)	
△4	1-696-846-21	CORD, POWER (AUS)	
△4	1-751-275-11	CORD, POWER (AEP,SP)	
△4	1-783-531-31	CORD, POWER (US,CND)	
5	1-569-008-21	ADAPTOR, CONVERSION 2P (SP)	
8	1-790-509-11	WIRE (FLAT TYPE) (17 CORE)	
11	1-783-140-11	WIRE (FLAT TYPE) (23 CORE)	
12	1-783-139-11	WIRE (FLAT TYPE) (21 CORE)	
16	1-569-972-21	SOCKET, SHORT 2P	
* 258	1-667-954-11	FLEXIBLE BOARD	
△260	8-583-028-01	OPTICAL PICK-UP KMS-260A/K1NP	
FL771	1-517-865-11	INDICATOR TUBE, FLUORESCENT	
HR901	1-500-502-11	HEAD, OVER WRITE	
M101	A-4672-475-A	MOTOR ASSY, SPINDLE	
M102	A-4672-474-A	MOTOR ASSY, SLED	
M103	X-4949-264-1	MOTOR ASSY, LOADING	
S102	1-762-148-21	SWITCH, PUSH (2 KEY)	
△TR901	1-433-693-11	TRANSFORMER, POWER (US,CND)	
△TR901	1-433-694-11	TRANSFORMER, POWER (AEP,UK,HK,AUS)	
△TR901	1-433-695-11	TRANSFORMER, POWER (SP)	

Ref. No.	Part No.	Description	Remark
		ACCESSORIES & PACKING MATERIALS *****	
	1-418-270-11	REMOTE COMMANDER (RM-29M)	
	1-558-271-11	CORD, CONNECTION (AUDIO 108cm)(UK)	
	1-574-264-11	CORD, OPTICAL PLUG	
	1-776-263-51	CORD, CONNECTION (AUDIO 100cm) (US,CND,AEP,SP,HK,AUS)	
	3-865-784-11	MANUAL, INSTRUCTION (ENGLISH)	
	3-865-784-21	MANUAL, INSTRUCTION (FRENCH, SPANISH, PORTUGUESE)(CND,AEP)	
	3-865-784-31	MANUAL, INSTRUCTION (GERMAN, DUTCH, ITALIAN)(AEP)	
	3-865-784-41	MANUAL, INSTRUCTION (SWEDISH, DANISH, FINNISH)(AEP)	
	3-865-784-51	MANUAL, INSTRUCTION (ENGLISH, POLISH, RUSSIAN)(AEP)	
	3-865-784-61	MANUAL, INSTRUCTION (CHINESE)(SP,HK)	
	4-981-643-11	COVER, BATTERY (for RM-29M)	

		***** HARDWARE LIST *****	
#1	7-685-646-79	SCREW +BVTP 3X8 TYPE2 N-S	
#2	7-685-133-19	SCREW (DIA. 2.6) (IT3B)	
#3	7-685-533-19	SCREW +BTP 2.6X6 TYPE2 N-S	
#4	7-621-772-20	SCREW +B 2X5	
#5	7-621-772-40	SCREW +B 2X8	
#6	7-627-852-08	SCREW,PRECISION +P 1.7X2.5	

The components identified by mark △ or dotted line with mark △ are critical for safety. Replace only with part number specified.	Les composants identifiés par une marque △ sont critiques pour la sécurité. Ne les remplacer que par une pièce portant le numéro spécifié.
--	--

Free Manuals Download Website

<http://myh66.com>

<http://usermanuals.us>

<http://www.somanuals.com>

<http://www.4manuals.cc>

<http://www.manual-lib.com>

<http://www.404manual.com>

<http://www.luxmanual.com>

<http://aubethermostatmanual.com>

Golf course search by state

<http://golfingnear.com>

Email search by domain

<http://emailbydomain.com>

Auto manuals search

<http://auto.somanuals.com>

TV manuals search

<http://tv.somanuals.com>