

SONY®

Cinema Processor System

DIGITAL FILM SOUND DECODER

DFP-D3000

DIGITAL FILM SOUND READER

DFP-R3000

SDDS Sony Dynamic
Digital Sound®

QUICK START GUIDE
1st Edition (Revised 1)

Table of Contents

Check List	3
1. Introduction	1-1
2. Equipment and accessories	2-1
3. Basic checks of site and installation	3-1
4. Checks of correct DFP-R3000 Reader mounting	4-1
5. A-Chain alignment using DFP-D3000 front panel controls	5-1
6. B-Chain Alignment	6-1
7. Overall systems check and listening test	7-1
8. Troubleshooting	8-1
9. Appendix	9-1
9.1 DFP-D3000 Rear Panel Connector Pin Assignment	9-1
9.2 DFP-D3000 Input/Output Level	9-4
9.3 Changeover Settings	9-5
9.4 Settings for using DFP-D3000 as DFP-D2000	9-6
9.4.1 Conditions	9-6
9.4.2 Connections and Settings When Connecting to the Output of the Existing System	9-6
9.4.3 Connections and Settings When Connecting to the Input of the Existing System	9-9
9.5 Description on Connection of DA-20 and DFP-D3000	9-12
9.5.1 Outline of System	9-12
9.5.2 Requirements at SDDS Side	9-12
9.5.3 Connections of the DA-20 and Setting the Operation Mode ...	9-12
9.5.4 Connections for Using AUX1 Input	9-13
9.5.5 Connections for Using AUX2 Input	9-15
9.5.6 Audio Connecting the DA-20 and DFP-D3000	9-17
9.6 Connecting the CP-500 and DFP-3000	9-18
9.6.1 Connecting the DFP-D3000 to the CP-500 with the DFP-D3000 as master	9-18
9.6.2 Connecting the DFP-3000 to the CP-500 with the CP-500 as master	9-23

9.7	Connecting the DTS-6, DTS-6D and DFP-D3000	9-26
9.7.1	Outline of System	9-26
9.7.2	Requirements of SDDS Side	9-26
9.7.3	Connecting the DTS Processor DTS-6	9-26
9.7.4	Connection of Control Signals from DTS Processor DTS-6D	9-31
9.7.5	Audio Connecting the DTS-6, DTS-6D and DFP-D3000	9-36
9.8	Corresponding to DFP-D3000 Surround EX	9-37
9.8.1	Restrictions on Control of Surround EX Decoder	9-37
9.8.2	Connections of Audio System	9-37
9.8.3	Actual Connection of Control System	9-39
9.8.4	SA-10 Operations When Controlling from the DFP-D3000	9-40
9.8.5	Controlling Surround EX from DA-20	9-41
9.8.6	Controlling Surround EX from DTS-6 or DTS-6D	9-43
9.8.7	Controlling Surround EX control from Automation Controller	9-43
9.8.8	Adjustments of Audio System	9-44
9.9	Test Cable for Performing A-Chain Adjustment	9-51
9.10	Adjusting the Analog Track Pickup	9-52
9.10.1	Preliminary Preparations Before Adjustments	9-52
9.10.2	Lateral Film Guide Adjustment	9-52
9.10.3	Lateral Exciter Lamp Adjustment	9-52
9.10.4	Lateral Solar Cell Adjustment	9-52
9.10.5	Vertical Adjustment of Exciter Lamp	9-53
9.10.6	Slit Lens Adjustment	9-53
9.10.7	Double Checking of Illumination Inconsistency	9-53
9.10.8	Wiring Check	9-53
9.11	Description of the DFP-D3000 Setup Software Menus	9-54
9.11.1	Start-up Screen	9-54
9.11.2	Description of File Menu Items	9-56
9.11.3	Description of Config Menu Items	9-57
9.11.4	Description of Preset Menu Items	9-58
9.11.5	Description of A-Chain Menu Items	9-59
9.11.6	Description of Tools Menu Items	9-60
9.11.7	Description of Master Menu Items	9-61
9.11.8	Description of Test Menu Items	9-62
9.11.9	Description of Help Menu Items	9-63

Note

SDDS is a registered trademark of Sony Corporation.
DTS, DTS ES and DTS Extended Surround are trademarks or registered trademarks of Digital Theater Systems, Inc.
Dolby, Dolby Digital and Dolby Surround are trademarks or registered trademarks of Dolby Laboratories Licensing Corporation.

Unless otherwise specified, all name of companies and products are trademarks or registered trademarks of the respective companies.

Check list

This is a step by step check list for the experienced installer. Refer to the associated sections of this Guide for additional information and see the Tech Notes for specific details.

	Page
1. Read about the advanced features of the DFP-3000 Player System.	1-1
2. Check that you have all necessary components and equipment.	2-1
2.1 Components included with the DFP-D3000 Decoder.	2-1
2.2 Components included with the DFP-R3000 Reader.	2-1
2.3 Additional equipment available from Sony.	2-1
2.4 Personal equipment you will need.	2-1
3. Perform basic checks of the Decoder.	3-1
3.1 Ensure that the Decoder's installed environment is acceptable.	3-1
3.2 Connect the Reader to the Decoder, turn on mains power, and confirm activity.	3-1
Caution! Do not hot-plug the Reader!	
3.3 Confirm that the Decoder firmware is version 2.74 or later.	3-1
3.4 Confirm that the Setup Software on your laptop is version 2.00 build 2.055 or later. Check Tech Note TN99121401 for the latest version.	3-2
3.5 Confirm a solid earth ground for the Decoder chassis.	3-2
3.6 Be sure that the optical input connector is wired correctly- it's not the same as others'.	3-2
3.7 Confirm that the interface wiring has been done properly. The Appendices and Tech Notes offer details on specific installation issues.	3-2
4. Confirm that the Reader is mounted correctly on the projector.	4-1
4.1 Confirm the correct installation for your projector according to the DFP-R3000 Installation Guide that comes with the Reader.	4-1
4.2 Be sure you have at least 32 frames between the Reader LEDs and the gate.	4-1
4.3 Make sure the film path is not twisted or misaligned.	4-1
5. Align the A-Chain.	5-1
5.1 Align and clean the solar cell and optics. See Tech Note 99111901 for details.	5-1
5.2 Connect your test cable, X-Y oscilloscope, and real time analyzer (RTA) to the front panel Headphone jack (see Tech Note TN99101201 for instructions on making this cable). Use Monitor Select position 1. Use the Decoder's front panel facilities to perform A-Chain calibration. ..	5-1
5.3 Go to the Config menu and enter the default password "SONY".	5-1
5.4 Play a tone loop and trim the gain for projector 1 (OPT1) L and R inputs. Block the slit slowly and confirm that R drops before L.	5-3

	Page
5.5 Play a B&W pink noise loop and set the slit loss EQ frequency for L and R. Repeat 5.4, 5.5, and 5.6 for the second projector of a changeover installation.	5-4
6. Align the B-Chain.	6-1
6.1 Connect your laptop to the Decoder's RS232 port with a null-modem serial cable, launch the Setup Software, and "connect" the Software to the Decoder.	6-1
6.2 Open the Master DFP-3000 screen and set the Master Volume to 0.0 dB and set the -20 dBFS output level reference to -10 dBu.	6-1
6.3 Zero out the Software on the main screen, link Mutes to Selects, and bring up the Test Signal screen.	6-1
6.4 Select pink noise; select All On; use PC function keys to select output channels.	6-2
6.5 Check that noise is coming from the selected non-sub channel at about 85 dB SPL, or 82 dB for the L and R surround speakers.	6-3
6.6 Use your RTA and each non-sub channel's graphic EQ to dial in the X-curve for each speaker except the subwoofer.	6-3
6.7 Adjust each screen speaker to exactly 85 dB SPL and the surrounds to 82 dB SPL.	6-3
6.8 Set the subwoofer channel's parametric EQ for smooth response ; set each preset's subwoofer low pass filter to 100 Hz or lower except SDDS, which should be higher.	6-4
6.9 Referring to your RTA, set the level of the analog subwoofer so that its bands are about the same level as the center speaker's bands in its flat response region.	6-4
6.10 Again referring to your RTA, set the level of the digital (SDDS) subwoofer bands to 10 dB higher than the flat bands of the center speaker.	6-5
6.11 Set the surround channel delay for each appropriate Preset.	6-6
6.12 Set AUX inputs' subwoofer levels to +10 dB, if other digital systems are installed.	6-6
	Page
6.13 Adjust the sync between optical tracks and SDDS.	6-7
6.14 Configure your presets for names, output matrix, and fallback.	6-7
6.15 Match levels between presets using the trims; set bypass levels; set HI levels.	6-10
7. Perform an overall systems checkout and listening test.	7-1
8. Refer to the Troubleshooting section for help with problems you encounter.	8-1
9. Appendix with connector pinout charts.	9-1

1. Introduction

The Sony DFP-3000 Cinema Processor forms the heart of the projection booth sound system in your theatre. It provides a sophisticated system for playing SDDS digital sound tracks, high quality optical soundtrack playback, comprehensive B-Chain control, and many other features. Here are just a few:

- The DFP-3000 system of projector-mounted reader and rack-mounted decoder perform traditional audio processing entirely in the digital domain. Inputs are processed with 20-bit A/D converters and then slit-loss EQ, noise reduction, and matrix decoding are all processed and adjusted digitally. After B-chain processing, fully balanced outputs are driven by 20-bit D/A converters.
- A comprehensive fallback system with two auxiliary inputs permits automatic playback of all three digital sound systems (by connecting the analog outputs of the other digital decoders into the AUX inputs of the DFP-D3000) as well as optical and non-sync inputs. You can select an AUX input to play in the event there is no SDDS digital soundtrack, a second auxiliary input to play if the first has no valid audio, and optical to play automatically if no digital soundtrack of any kind is available.
- The B-Chain system of the DFP-3000 is exceptionally flexible. It provides seven channels of multi-band graphic equalization, surround delays, subwoofer parametric EQ and separate low pass filter for optical and digital play, and many other functions. These are all implemented in powerful DSP's to make setup fast and easy using Windows-based software.
- SDDS Fader Automation lets you set levels reel by reel. Your settings are retained in non-volatile memory and automatically restored whenever that reel is played again.
- A front panel headphone monitor with selection switch lets you perform many tests using headphones or test equipment directly at the decoder front panel.
- The DFP-3000 is designed for professional applications as well as cinemas. It has balanced inputs and outputs for lowest noise and you can select professional operating references if required.

This Quick Start Guide is intended to assist experienced cinema engineers in systematically installing, setting up, and maintaining the Sony DFP-3000 cinema processor system. Instructions are complete, but brief. For more detailed information, Sony offers the following comprehensive manuals:

- DFP-R3000 Installation Manual (for installation of the Reader)
- DFP-R3000 Maintenance Manual (for component-level service of the Reader)
- DFP-D3000 Maintenance Manual (for component-level service of the Decoder)

The information in this Guide is presented in the same order that most cinema engineers follow when setting up a new theatre. If you go through the sections step-by-step you will be sure to touch on the most important points.

Sony Cinema Products would like to hear from you. We hope you will contact us and tell us your experiences in using this Guide so that we may constantly improve its value to you.

2. Equipment and accessories

Your purchase of a DFP-3000 system includes the following items in two boxes:

In the Reader box you will find :

2.1 Digital Film Sound Reader Unit	1	DFP-R3000
Reader-to-Decoder Cable, 10 meter*	1	1-783-382-11
Adapter EA	1	3-194-819-03
Spacers	4	
Bolt, Hex 3/8"	4	3-185-981-01
Washer 10	4	7-688-000-32
Screw, Hex 4 × 12	5	7-683-421-04
Washer 4	5	7-688-004-12
Spring Washer 4	5	7-623-210-22

2.2 In the Decoder box you will find:

Film Sound Decoder Unit	1	DFP-D3000
AC Power Cable	1	Varies by Country
Plug Holder	1	Varies by Country
AC Adapter (backup supply)	1	Varies by Country
Operation Manual	1	3-862-212-02

2.3 Personal equipment you will need:

Personal computer (laptop) running Windows 3.1 or later	486-66 with 32 Mb RAM, Floppy drive, serial port, 20 Mb available disk space.
Null modem cable, RS232C	Pentium 120+ MHz recommended
Real Time Analyzer	With 9-pin male on D3000 end
Oscilloscope	With calibrated microphone (s)
Allen wrench set, ANSI	2-Ch, 10 MHz minimum
Allen wrench set, Metric	Up to 3/8-inch
Tweaker	Up to 6 mm (small straight slot screw driver)

2.4 The following additional equipment is available from Sony:

Connector kit	Free	STK-2202
Setup Software	Free	STK-2233
Test Film Kit		Contact Sony
#1 JIS screwdriver, cross point type		7-700-749-03
Reader-to-Decoder Cable, 50 meter*		1-783-896-11

*Neither the 10 meter nor 50 meter cable can be cut, spliced, or re-pinned.

3. Basic checks of site and installation.

Before you begin making settings and adjustments to your DFP-3000 system, it's best to confirm some basic conditions. Here is a check list.

3.1 Check that the Decoder environment is suitable.

The DFP-D3000 Decoder is intended to be mounted in a rack chassis along with other cinema equipment. However, it should not be mounted in close proximity to power amplifiers or other equipment which may radiate strong magnetic fields or which give off high heat. Observe the ambient temperature limit of 40° C (104° F) and if the interior of the rack is excessively warm, provide more ventilation to lower the temperature.

Note

Do not “hot plug” the Reader! The Reader gets its power through the cable that connects it to the Decoder. Do not remove or install this cable while the Decoder AC power is on. Doing so may cause damage to the Reader and void its warranty.

3.2 Confirm basic power up activity.

Connect the Reader to the Decoder using its cable. Note that this special cable cannot be cut or spliced. Connect the line cord to a mains supply of 100-240 VAC 50/60 Hz and connect the backup power supply to a mains supply for which it is rated. The LED in the SELECT switch will be illuminated Red. Switch on the Decoder. The SELECT switch LED will go out, the LCD display will be illuminated, the MASTER LEVEL numerical display will go through a brief count and then display its last +/- dB setting. The illuminated PRESET switch shows the last and current Preset selected and the LCD display shows its name and any fallback Preset that is assigned to it.

3.3 Confirm the proper version of Decoder firmware.

The instructions contained in this Guide relate to functions and features associated with DFP-D3000 firmware versions v2.74 and higher. See TN99121401 for the latest versions of all forms of firmware and software for Sony cinema products. The following steps illustrate how to display the DFP-D3000 firmware version on the front panel LCD screen:

1. Select any Preset by pressing its PRESET button twice. The display should appear as illustrated.

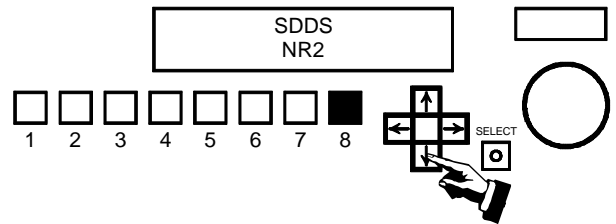

2. Press the  button.

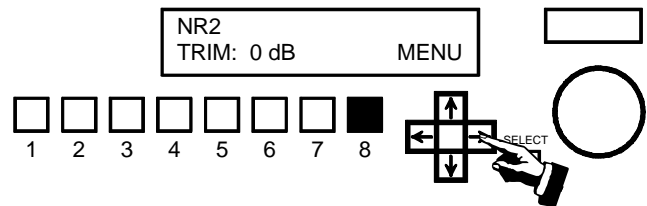

3. The NR2 TRIM value will now be flashing. Press the  button so that the MENU option is flashing.

4. With the MENU option flashing, press the SELECT button.

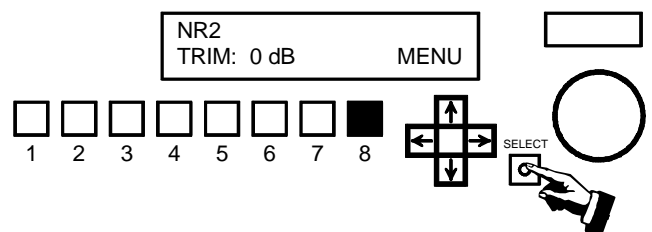

- The STATUS option will now be flashing. Press the SELECT button again.

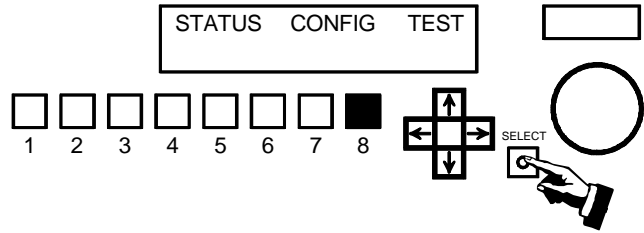

- The firmware version will now be indicated in the upper right corner of the LCD display.

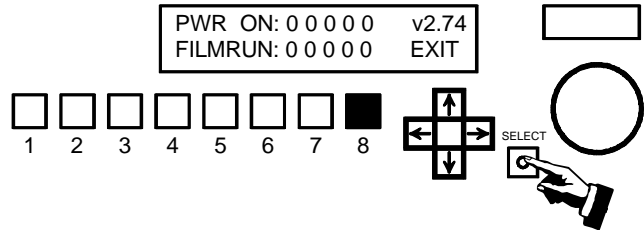

- Press the SELECT button while the EXIT option is flashing to leave this area of the menu system.

3.4 Check the version of the Setup Software on your computer.

The Setup Software is updated frequently. Be sure you are using the latest version, which will be v2.00, build 2.055 or higher. You can check the SDDS web site or contact Sony Cinema Products to determine the latest version and to request a free copy. You can check the version of Setup Software you are using by launching the program and selecting **Help>About. . .** from the pull down menu at the top of the main screen.

3.5 Confirm a proper chassis earth ground.

Most audio grounding schemes require that the chassis of the DFP-D3000 have a solid electrical connection to the rack in which it is mounted. The finish on the rack mounting rails may be very durable. Make sure that the mounting screws cut through the finish of the DFP-D3000 and that the mounting ears make electrical connection through the rack rails' finish to the rack itself. Test this with an ohm meter. Additionally, a screw terminal Technical Ground is available on the back panel of the Decoder, to help make a solid ground connection. Do not remove the line cord safety ground pin in an attempt to avoid ground loops. This precaution is already taken care of in the design of the DFP-D3000 and removing the pin will have no benefit, but doing so will compromise electrical safety and may violate electrical codes.

3.6 Check the optical input connector wiring.

Make sure that the optical input connector is wired according to the pinout diagram in the Appendix. Use individually shielded twisted pair cable. See Chapter 5, A-Chain Alignment, for information regarding the optical pre-amp test points. Note that the wiring of this connector may not correspond to that of other cinema processors.

3.7 Confirm proper audio interface wiring.

The Sony DFP-D3000 Decoder unit uses professionally balanced audio interface connectors, pinned according to the THX convention, for interconnections to amplifiers, crossovers, limiters, booth monitors, and other cinema processors. Unfortunately, many such devices do not employ balanced inputs or outputs. It is essential that proper balanced to unbalanced interface wiring techniques are used when connecting to these devices so as to ensure optimum operating conditions for the DFP-D3000 and connected equipment. Failure to use proper techniques in your sound rack wiring may result in reduced system headroom, improper theatre calibration, and compromised sound performance. For a guide to properly interconnecting balanced and unbalanced audio signals, refer to Tech Note TN99060401.

Wiring of other equipment.

This following is an illustration of the DFP-D3000 rear panel.

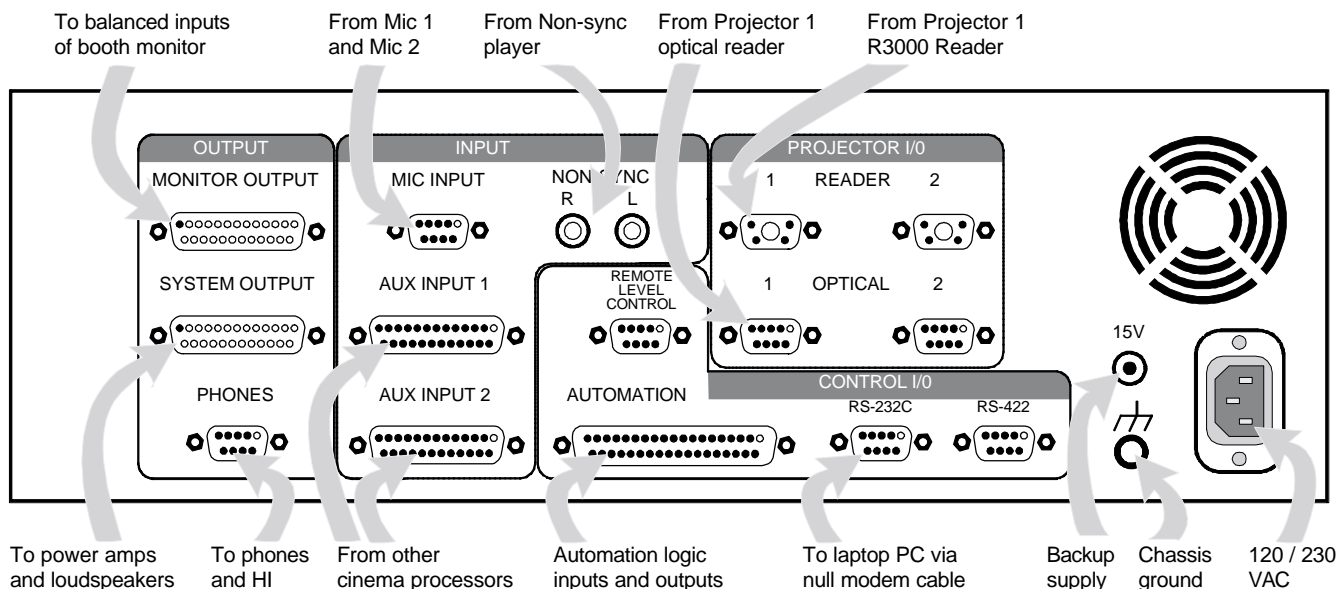

Note that these D-Sub connectors have metric (M2.5 × .45) jack screw receptacles and require mating connectors with metric jack screws. A kit of such connectors is provided with each DFP D3000. **Do not use standard D-Sub connectors with 4-40 jack screws.**

Cinema processors.

Refer to the list of available Tech Notes in the Appendix of this Guide for instructions on correct audio and logic interconnections to other cinema processors. Note that Sony connectors use the THX® pinout convention, but other equipment may not. Therefore, pre-fabricated cables or cables made with flat ribbon computer-type cable are generally not acceptable for use with the DFP-D3000. The DFP-3000 cinema processor is capable of exceptional performance; do not degrade this by using inferior cables. Sony strongly recommends that all audio interconnections in your cinema sound rack be made using high quality audio-grade twisted pair shielded cables or individually shielded multipair cable. Contact your dealer for information regarding pre-wired audio cables for the DFP-D3000, available from several cinema accessory distributors.

Non-sync inputs.

The non-sync inputs of the DFP-D3000 are on consumer standard RCA-type connectors. One dedicated non-sync input is available. If additional non-sync inputs are required, the MIC1 input can easily be configured for line level operation, and the two eight-channel AUX inputs can serve as additional line level inputs for electronic projectors, DVD, magnetic film dubbers, and other external analog sound sources.

Microphone inputs.

The MIC1 and MIC2 inputs have built in microphone preamplifiers, so that external mixers or line-matching devices are not required to directly connect a microphone level input. Input connections are balanced on a single D-Sub 9-pin female connector. 48-volt phantom power for condenser microphones is available, and can be switched on using the setup software or the front panel. See the instructions for MIC configuration later in this Guide for more detailed information.

AUX inputs.

If either of the two 8-wide balanced AUX inputs are used for sources other than cinema processors, take note that the sophisticated automatic fallback system of the DFP-3000 requires these inputs to be enabled by a logic command to make them active. To use AUX1 or AUX2 for external sound sources other than digital film sound decoders, short Pin 34 (AUX1 DATA OK) or Pin 35 (AUX2 DATA OK) to GROUND on the Automation connector to enable the AUX1 or AUX2 inputs. See Tech Note TN99042801. Another approach is to chose No Fallback (*) as the fallback option for an AUX Preset, which prevents fallback and so forces the AUX input to play whenever it is selected.

Headphones and HI output.

A single D-Sub 9 pin connector provides a L/R stereo headphone output from the back panel. This is a parallel of the front panel headphone jack and is affected by the MONITOR SELECT switch and HEADPHONES level control. This connector also has two pins providing MONO outputs, which can be used to feed most Hearing Impaired transmission systems. Signal level for the HI outputs can be calibrated by an adjustment control located inside the Decoder. Detailed instructions for Hearing Impaired output level adjustment is discussed in Section 6.15 of this Guide.

Automation inputs and outputs.

All automation logic inputs and outputs are brought to a single 37-pin D-Sub connector on the DFP-D3000. For a complete description of the connections available, see Tech Note TN99042801. Other Tech Notes describe specific means of connecting to other types of cinema equipment; see Tech Note TN99070701.

RS-232C connector.

This 9-pin female D-Sub connector is used to connect an external PC-compatible computer using a null-modem cable.

RS-422 connector.

Contact your Sony service or sales representative for details on the use of this connector.

Remote level control.

Remote control of the Master Volume is possible by connecting a 100k-ohm linear taper potentiometer. The wiring convention of this potentiometer is unique to Sony, so follow the documentation in the Appendix carefully.

Bypass (backup) power supply.

The DFP-D3000 is provided with an external DC power supply which provides emergency power to bypass components within the Decoder. This power supply allows the Decoder to continue playing optical tracks in the event its main power has been turned off. Check that this power supply has the correct AC mains voltage rating for your country and is connected to the AC mains and to the back of the Decoder. A small red LED in the SELECT switch on the front panel of the Decoder indicates when the unit is being powered only by the backup power supply.

4. Checks of correct DFP-R3000 Reader mounting.

Do not “hot plug” the Reader!

The Reader gets its power through the cable that connects it to the Decoder. Do not remove or install this cable while the Decoder power is on. Doing so may cause damage to the Reader and void the warranty.

4.1 Confirm the minimum frame offset.

Specific installation instructions for mounting the Reader to each type of projector are available in the DFP-R3000 Installation Guide provided with the Reader. Following these instructions will ensure at least the minimum frame offset between the Reader’s LEDs and the picture gate. The Reader LED offset must be at least 32 frames ahead of the projector gate. Since the loop ahead of the intermittent affects this offset, use a nominal loop when making this determination. The maximum total frame offset possible with the DFP-3000 is 115 frames.

4.2 Check the film path alignment.

Proper alignment of the film path entering and exiting the Reader, as well as adequate tension on the incoming film, is essential to correct operation of the DFP-R3000 Reader. Carefully check that the all rollers on the in-feed mechanism, the Reader, the Adapter plate, and the projector are aligned and that no twisting of the film path occurs. Adjust the positioning of the Reader if necessary.

5. A-Chain alignment using DFP-D3000 front panel controls

The most direct means of A-Chain alignment is to use with external test equipment and the controls available through the Decoder front panel. There are two approaches. The first, recommended for experienced cinema engineers, is to align the projector's optical playback system so as to produce nominal settings (preset gain = 0.0 dB) in the DFP-D3000. This has the potential benefit of best sound quality as preamplifiers, noise reduction, and matrix decoding circuits will be operating at optimal levels. The second approach is to set the DFP-D3000 to match the existing alignments in the projector's optical playback system. This approach has the benefit of ease of setup, but requires that the optical system is already correctly aligned. Gain trims should end up near 0.0 dB with a properly aligned projector. With either approach, it is important to first ensure a high quality optical system alignment. For detailed instructions on aligning a forward scan optical reader system, see Tech Note TN99111901; to align a specific brand of reverse scan reader, follow its manufacturer's documentation.

5.1 The following instructions require that the projector's optical reader has been properly aligned, the projector is mechanically sound, and its optical playback system is clean. See TN99111901 for instructions on aligning a forward scan optical reader.

The initial steps for A-Chain alignment are common to both alignment approaches.

5.2.1 Prepare a test cable.

This cable connects from a standard 1/4-inch stereo phone plug to the input connectors of your multichannel Real Time Analyzer (RTA) and simultaneously to the inputs of your dual-channel X-Y oscilloscope. The front panel phone jack on the Decoder has line-level output signals wired with Tip = Lt, Ring = Rt, and Sleeve = audio common (ground). The Lt and Rt signals connect to each input of your RTA and to the horizontal and vertical inputs of your oscilloscope. See available Tech Note TN99101201 for details on making up this test cable.

5.2.2 Connect the test cable.

Set up your oscilloscope for X-Y display, i.e., to display phase relationships between two equal signals. Connect the test cable to the X and Y oscilloscope inputs. Connect Lt or Rt to your RTA input. Insert the phone plug end of the test cable into the headphones jack on the front panel of the DFP-D3000.

5.2.3 Set the MONITOR SELECT switch of the Decoder to position 1 (the LCD screen will briefly display L+LC+C+SL/R+RC+SR). Set the adjacent HEADPHONES volume control to the 12:00 (straight up) position.

5.3 Enter the A-Chain access password in order to adjust preamplifier gains and set the slit loss equalization frequency. You will need to play customary alignment films at times during this process. The default A-Chain password is "SONY".

5.3.1 Select any Preset other than non-sync by pressing its PRESET button twice. If you have selected Preset 8 for SDDS the LCD display will appear as illustrated.

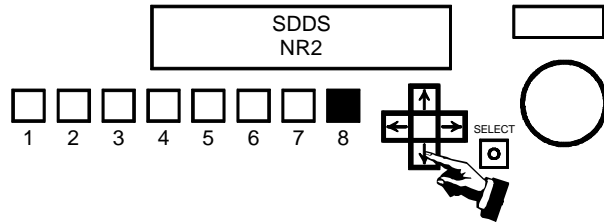

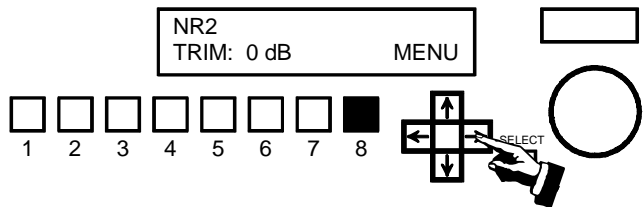

5.3.2 Press the  button.

5.3.3 The NR2 TRIM value will now be flashing. Press the  button so that the MENU option is flashing.

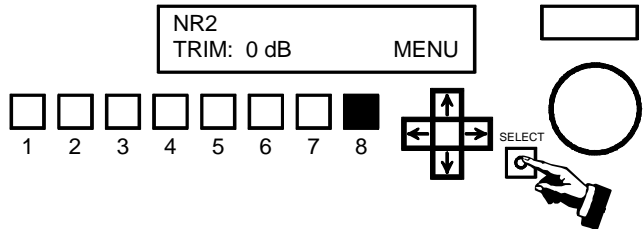

5.3.4 With the MENU option flashing, press the SELECT button.



5.3.5 The STATUS option will now be flashing. Press the  button again. This will cause the CONFIG option to flash.

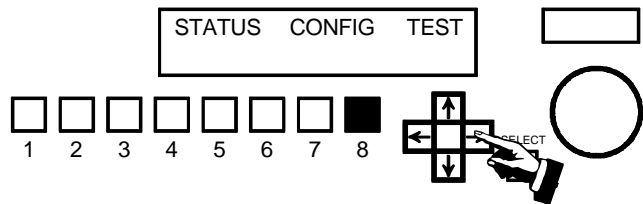

5.3.6 With the CONFIG option flashing, press the SELECT button.

5.3.7 Turn the MASTER VOLUME control clockwise until the first character in the password field is changed to "S". The default A-Chain password is "SONY".

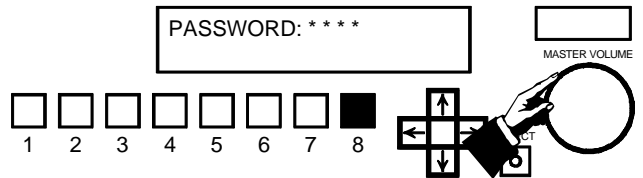

5.3.8 When the first character becomes "S", press the SELECT button to enter it and move to the next character. Continue using the MASTER VOLUME control and SELECT button to enter all characters of SONY.

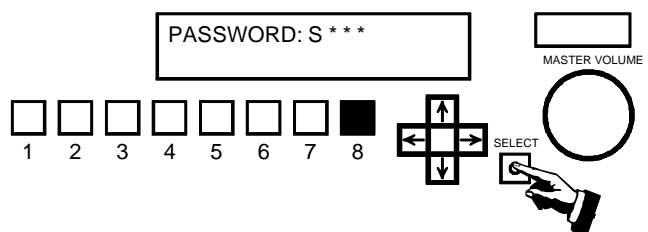

5.3.9 When you enter the last correct character you will see the ADMIT option flashing. Press the SELECT button to proceed to the A-Chain functions menus.

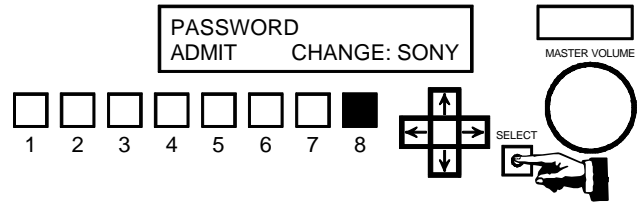

5.3.10 This is the A-Chain Calibration menu for OPT1L (the left optical input from projector 1). Use the buttons to select among left and right inputs from two projectors and the buttons to select between Slit Loss and Gain adjustments. The MASTER VOLUME control adjusts the values of GAIN or S_LOSS.

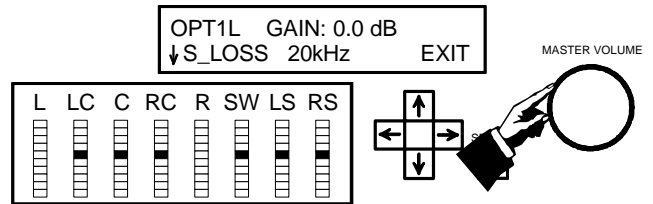

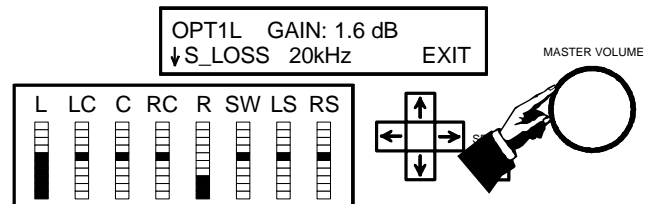

You must now decide whether to align the optical reader to the DFP-D3000 or the DFP-D3000 to the reader. If you decide to adjust the reader to achieve gain settings of 0.0 dB (or as close as possible) you must make adjustments to the exciter lamp voltage or reverse scan preamplifier gain, and possibly other adjustments, according to your experience. Otherwise, use the following steps to adjust the DFP-D3000 to accommodate the correctly aligned reader's output.

5.4a Play a Calibration Tone loop. The signal amplitude will be indicated on the L and R meters, while the single LED on the remaining meters serves as a reference. Use the Master Volume control to set the gain for the Left optical input from projector 1 (OPT1L) to match the single LED's as shown. Note that the meter sensitivity in this calibration mode is much higher than in normal film playback operation.



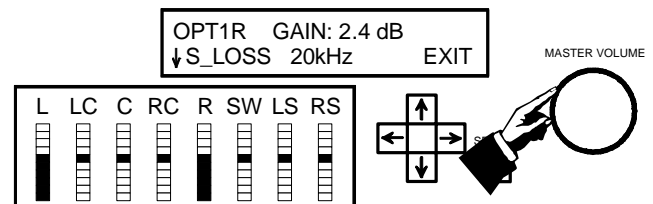

5.4b Use the buttons to select the Right optical input (OPT1R) and use the Master Volume control to set the gain so that the signal level is correct. If you chose to align the reader to the DFP-D3000, you would have the L and R bars aligned to match the single LED's and all gain settings would be at 0.0 dB.



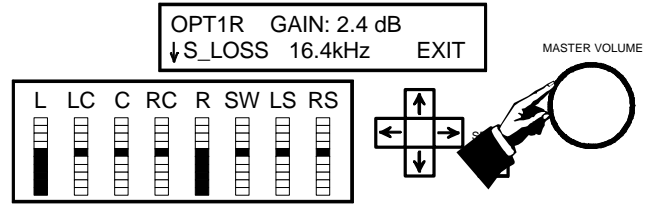

5.5a Use the   buttons to change the selected parameter to slit loss (S_LOSS). Play a B&W Pink Noise test film and use the Master Volume control to adjust the slit loss frequency to achieve the flattest response, as indicated by your RTA. The result that is achievable depends on the slit height and other properties of the reader and the actual high frequency flatness of your pink noise test film.

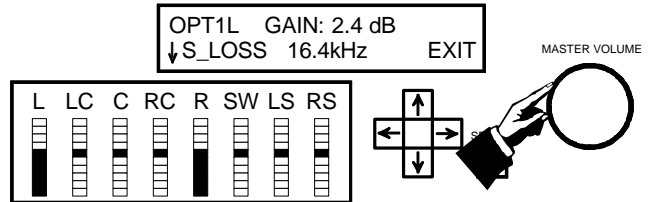

5.5b Use the   buttons to return to the Left optical input and use the Master Volume control to adjust the slit loss compensation frequency to achieve the flattest response.



This completes the A-Chain alignment procedure. To return to the main LCD menu, use the   buttons to select the EXIT option and press the SELECT button. You may also press any PRESET button twice to exit all menus and return the Decoder to normal operation with that Preset selected and its parameters loaded.

6. B-Chain Alignment

B-Chain alignment is performed using the DFP-D3000, Setup Software, and your own test equipment. To begin, connect your computer to the Decoder using a null modem cable, launch the Setup Software, and “connect” the Setup Software to the DFP-D3000 using the **Config>Connect to DFP...** menus. Set up your microphones and analyzer (THX R2 or other multichannel real time analyzer) in the theatre. Refer to SMPTE Standard 202M, B-Chain Electroacoustic Response, for more detailed information on microphone placement, theatre acoustics, and the “X” curve. Note that the DFP-D3000 must be set up with the Master Fader nominally set to 0.0 (not 7) and that from this position 10 dB of boost and full cut is available, with an audio/dB fader taper.

6.1 Open the **Master DFP-3K Settings** screen by selecting **Master DFP-D3000** under the **Master** option in the main screen menu bar.

6.2 Ensure that the **Master Volume** is set to **0.0 dB**. Select the appropriate output level for the DFP-D3000; this is the absolute signal level that corresponds to the -20 dBFS reference point. In most cases you should chose -10 dBu (145 mV).

Use your real time analyzer (RTA) to check the SPL in the theatre and ensure that it is in the right range when the Master Volume is 0.0 dB.

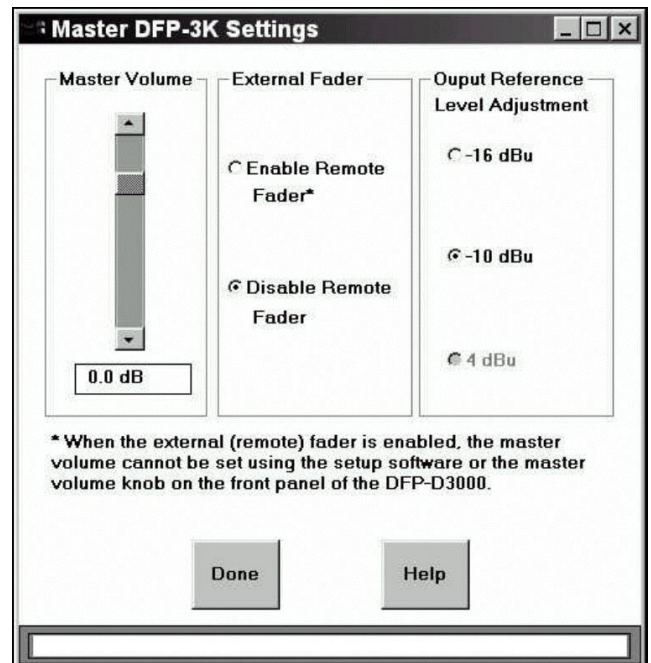

6.3a Move **all** Channel Level Trims to the center setting (0.0 dB). Center all equalizer sliders at 0.0 dB. To quickly set all EQ levels to 0.0 dB, access the **Reset Channel** function in the **Tools** pull-down menu located in the main screen menu bar. The illustration shows the main screen of the Setup Software in this condition, for the Left output channel.

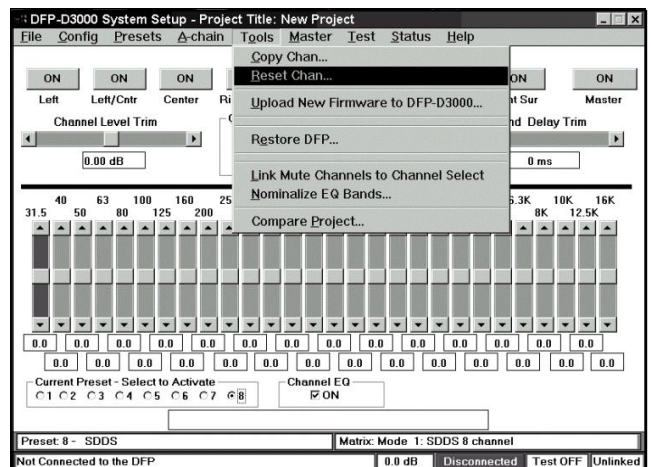

6.3b Link the channel mutes to the channel selects using the **Tools** selection of the main screen and selecting **Link Mute Channels to Channel Select**.

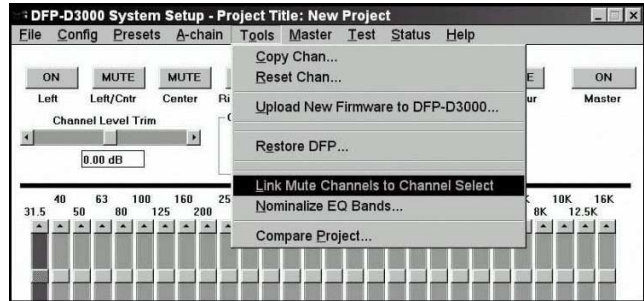

6.3c To bring up the **DFP Test Signal Generator** screen, select the **Signal Generation** option under the **Test** item on the main screen menu bar.

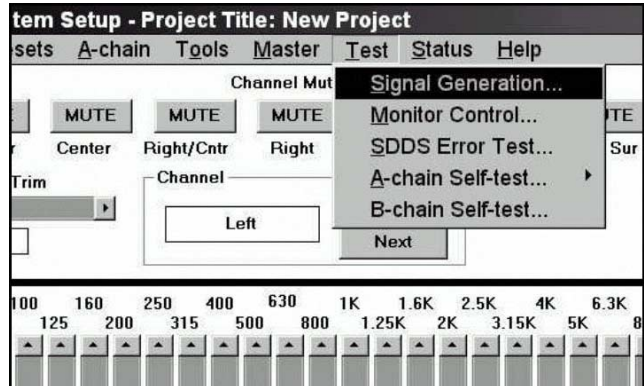

6.4a Select **Pink Noise** in the **Signals** area. Pink noise can be sent to the outputs only at -20 dBFS. This is handled automatically by the software.

6.4b Enable all outputs by selecting **All On** in the **Output Channel** area. The software automatically mutes all channels to prevent accidentally sending loud sounds into the theatre.

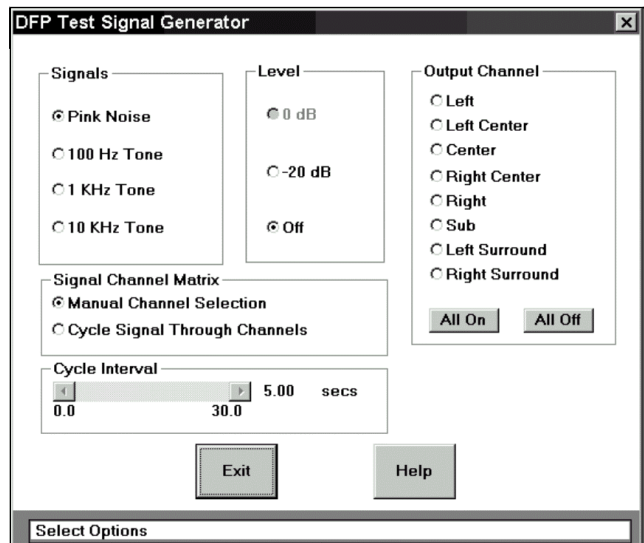

When **All On** is selected, a warning will appear. Read it carefully and select **Yes** if you wish to continue.

When you finish the setup, return to the main screen by pressing **Exit**.

Note that the bottom of the main screen now shows **PINK** to indicate that pink noise is being generated and **Linked** to show that channel mutes are linked to channel selects.

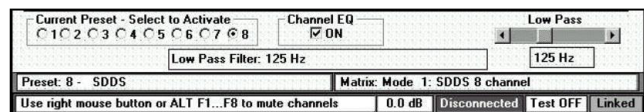

6.4c B-Chain alignment is performed on output channels individually. You can use the function keys as an aid in channel selection or use the MUTE/ON buttons illustrated in 6.3a. Because the channels are linked, pressing a function key or button selects and un-mutes (turns on) that channel while muting (turns off) all other output channels.

Function Key	Channel
F1	Left
F2	Left Center
F3	Center
F4	Right Center
F5	Right
F6	Subwoofer, (LFE)
F7	Left Surround
F8	Right Surround

6.5 Now select each output channel in succession, confirm that the noise sound is coming from the correct loudspeaker, and adjust the channel's equalization and level. Start by adjusting the equipment between the System Outputs of the DFP-D3000 and the loudspeakers to achieve about 85 dBC SPL in each screen loudspeaker, measured individually (82 dBC for each of the two surround channels). This equipment may include crossovers and power amplifiers from a number of manufacturers so specific instructions cannot be given here. Sony recommends using several measurement microphones and a microphone multiplexer to drive your RTA, but each engineer will have their own preferred measurement techniques.

6.6 Adjust the graphic equalizer to achieve the "X" curve of SMPTE 202M, or other frequency response that has been established for your theatre. Do this for each loudspeaker attached to an output channel, except the subwoofer. Setting the graphic equalizer for best results requires skill and experience, but a few general points can be made. Make small adjustments and let the RTA display settle down after each adjustment. Cutting EQ is always better than boosting EQ. Adjacent bands with boost and cut differences of more than 3dB indicates problems that aren't appropriate for EQ to correct; try to end up with a smooth equalizer setting using as little EQ as possible and no more than a few dB difference between adjacent bands. Use even less EQ on the surround loudspeakers. The screen speakers should all have the same EQ settings (if they are the same cabinet type); if they aren't very close, there may be problems that EQ should not be used to address. Don't boost low bands in an attempt to extend the low frequency response; that is mainly determined by the cabinet design. Remember that you can only adjust for the sound that comes directly from the loudspeakers to the measurement microphone; you cannot do much about the sound that is influenced by the auditorium acoustics or resonances and you should avoid the temptation to try to do so. If you see wide variations when you move your microphones around in the auditorium, position them closer to the front so as to measure more sound direct from the loudspeakers and have less influence from the sound that has bounced around the auditorium (which you can't affect with EQ).

6.7 When all loudspeakers except the subwoofer have been EQ'd, make a wideband adjustment in the equipment between the DFP-D3000 and each of the loudspeakers (such as with a power amplifier gain control) to achieve 85 dBC SPL from each screen loudspeaker. This is a wideband sound pressure measurement; at this point, the individual bands of your RTA will each be at about 70 dB SPL. The left and right surround cabinet groups should each be set for 82 dBC wideband. It is better to achieve this result with an adjustment of amplifier gain than by using a Channel Level Trim, and when using a Channel Level Trim, it is better to preserve full headroom by using attenuation (cut, or -dB) instead of gain (boost, or +dB).

6.8 To set the equalization for the subwoofer loudspeaker, press F6 to select the Subwoofer output channel and bring up the 2-band parametric equalizer. Verify that sound is coming from the subwoofer loudspeaker cabinet.

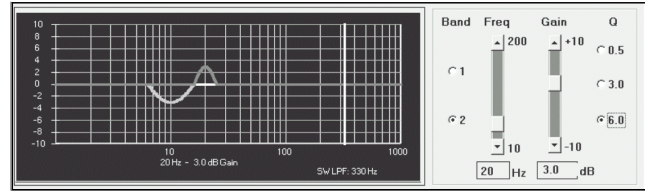

Adjusting the subwoofer equalizer is especially difficult and benefits from experience with the particular cabinet model used. Use as little EQ as possible and allow your RTA display extra time to settle between adjustments. Aim for a smooth, rather than extended, response. Note that the higher frequencies are rolled off by the subwoofer low pass filter, whose frequency is shown below the graphic display and is indicated by the vertical yellow line. Use 330 Hz for this step and reduce the setting later, using separate settings for optical, digital, and other presets.

The analog subwoofer channel level trim affects the subwoofer output level of all eight presets. The SDDS subwoofer level is an offset trim from this value. The AUX subwoofer offset settings are also offset from the analog subwoofer channel level trim.

6.9 The recommended method of setting the analog subwoofer level is to use the internal pink noise generator as you have previously done for the screen speakers and adjust the subwoofer power amplifier input gain control and the subwoofer level trim (which is essentially in series with the subwoofer power amplifier's input gain control) to make the subwoofer's RTA bands match the level of the Center channel's RTA bands where they are flat. Use attenuation in preference to gain at the subwoofer level trim and achieve gain with the subwoofer power amplifier's input control. When you make a change to the Analog Channel Level Trim slider while the Subwoofer output channel is selected, the software will automatically select a non-SDDS Preset.

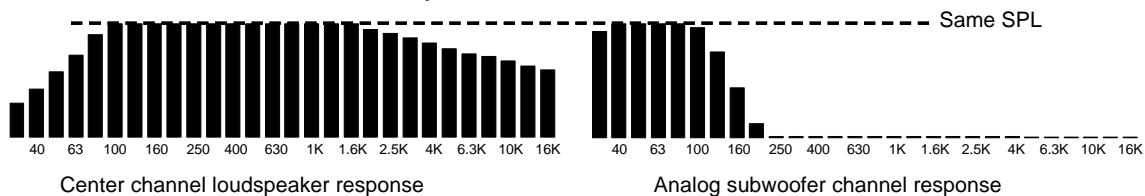

Purists may want to set the optical subwoofer level by playing a pink noise loop and adjusting to make the overall response of the screen speakers as flat and extended as possible as a result of the subwoofer's supplementation. This technique is beyond the scope of this Guide.

Recognize that the **SDDS** (and other digital formats') **subwoofer** is an effects channel that delivers low frequency sounds that are designed to enhance certain elements of a particular film. The **analog subwoofer** is derived from the optical L,C,R channels and is intended to compensate for limitations of the screen speakers being used; modern, full-range screen loudspeakers may need little or no analog subwoofer supplementation. For a longer discussion, see Tech Note TN99051701.

The low pass filter frequency for the optical preset must first be set to match the response of the subwoofer to the response of the screen speakers. Wide range screen speakers can have the optical subwoofer low pass filter set to the lowest value of 80 Hz; 100 Hz is a good starting point for most modern screen loudspeakers.

What ever method is used, a final listening test, using film having a high quality optical track with familiar, wide range content should be auditioned to ensure that the subwoofer level is set for best sound and optimal low frequency balance. If you use a non-sync audio source, such as a music CD, for this test, be sure to select Mode 6, 7, 8, or 9 for your non-sync Preset in the Preset Configuration screen (see Step 6.11), so that the analog subwoofer output is active.

6.10 When adjusting the SDDS subwoofer (LFE) level offset, the SDDS Preset must be made the active Preset. Select the preset manually with the **Active Preset** option under the **Presets** item in the main screen menu bar and then selecting the SDDS Preset, or by clicking the appropriate radio button at the lower left of the main screen.

8 is the default preset for SDDS. Press F6 to manually the subwoofer output channel. Alternatively, the software will automatically select the SDDS Preset when you have selected the Subwoofer output channel and click the SDDS Subwoofer Offset slider.

Use the **SDDS Subwoofer Offset** slider control and your real time analyzer (RTA) to set 10 dB of in-band gain of the subwoofer's bands as compared to the previously calibrated Center speaker's bands in the region of its flat frequency response. Be sure to allow extra time for the low frequency bands to settle to their final values.

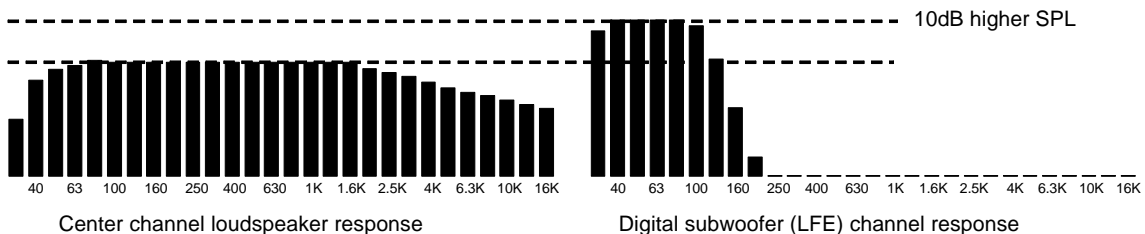
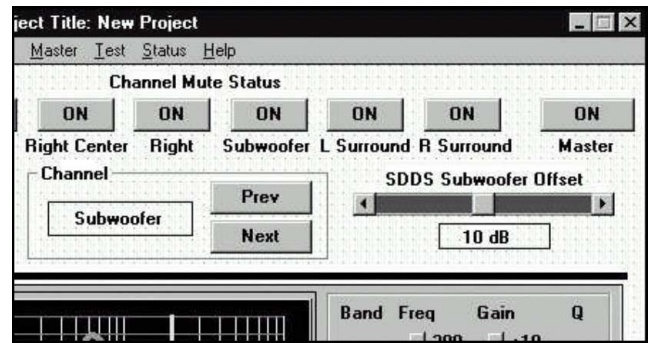

This procedure, which requires an RTA, matches the playback gain of the SDDS Preset's subwoofer loudspeaker in the cinema to the playback response of the digital subwoofer (LFE loudspeaker) on the stage where the film's sound track was mixed.

When evaluating the SDDS digital subwoofer (LFE) level, no listening test is entirely definitive, because the amount of energy in the LFE channel is a creative decision made when the soundtrack of each film was mixed. For the same reason, the digital subwoofer (LFE) low pass filter setting has no relationship to the screen loudspeakers' performance. It merely serves to exclude undesirable sound from the subwoofer (LFE) cabinet. The actual sounds reproduced on the digital subwoofer (LFE) channel are determined by what was put there by the film's sound mixer, as long as the filter frequency is not set so low as to remove sounds the mixer intended to be included. Setting the digital subwoofer low pass filter frequency to 100 to 200 Hz should be acceptable and either setting should sound the same when actual film is exhibited; start with 160 Hz. Subwoofer manufacturers may have specific recommendations for their cabinets.

Note that the result of a wideband SPL measurement of pink noise from the SDDS subwoofer (LFE) will depend on both the level Trim setting and the low pass filter Frequency setting. For a LPF frequency setting of 100 Hz, a wideband measurement made with an SPL meter will show approximately 91 dB. Such a measurement should only be made to confirm that a correctly calibrated theatre has not drifted, and cannot be used as a primary calibration measurement in place of an RTA. Also remember that the analog subwoofer channel trim is effectively in series with the subwoofer amplifier's input gain control. This means that **an adjustment to the analog subwoofer channel trim also affects the playback level of all digital subwoofer signals.**

Note that the graphic and parametric equalizer settings adjust for the frequency response of each of the loudspeaker cabinets in the theatre. This means they affect the output from all Preset inputs. The output channel level trims, including the analog subwoofer channel level trim, also affect all Presets. These settings are retained in the DFP-D3000's non-volatile memory as a single set of overall adjustments to the playback system. Other settings, such as subwoofer low pass filter frequency and surround speaker delay, may be unique to each format or signal source. These values are stored as individual settings for and within each of the eight Presets.

6.11 To set the surround channel delay and enable it for each Preset, bring up the **Preset Configuration** screen by selecting the **Preset Configuration** option under the **Presets** item in the main screen menu bar. This screen allows you to select each Preset, make a level trim (to balance the relative level of each Preset), set a surround delay, and set the subwoofer low pass filter (LPF) frequency for that Preset.

In the latest versions of software you can also set surround delay and subwoofer LPF frequency at the main screen, according to the output channel selected.

The surround channel delay can be set with elaborate science based on SMPTE 202M. However, an easy rule-of-thumb approach is to set the milliseconds of delay for optical sources (NR2) to equal the length of the theatre (in feet) +10. For digital sources (SDDS) it should be set to 60 % of the optical surround delay.

6.12 If a cinema digital audio system is connected to one of the AUX inputs, you must set its corresponding subwoofer input level offset. The playback level of the subwoofer in today's cinema digital audio systems is offset by 10 dB. To access the **AUX Input Calibration** screen, select the **AUX Inputs** option from the **A-chain** item in the main screen menu bar. Click to select the correct offset.

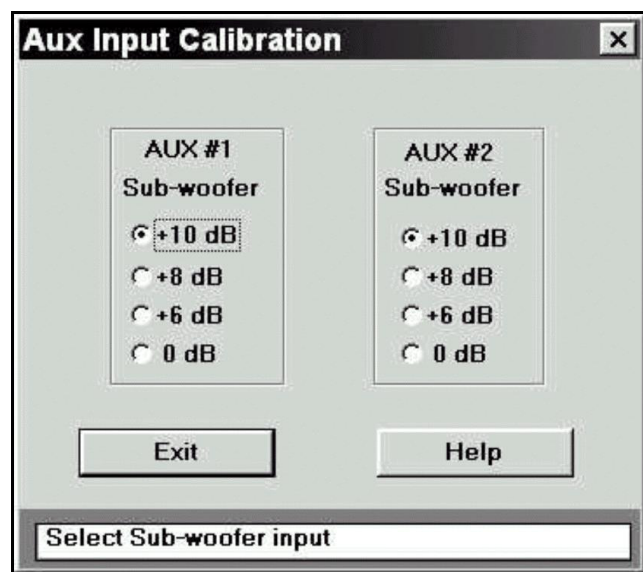
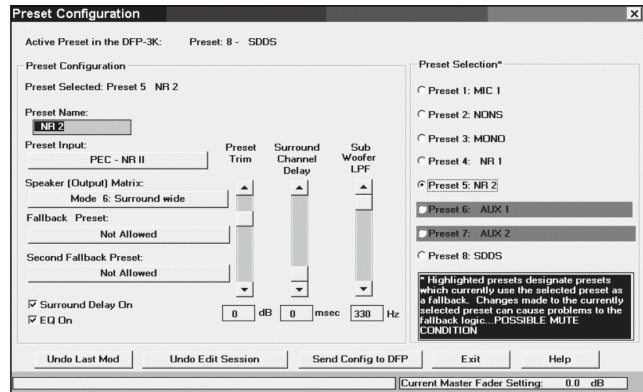

6.13 To adjust the synchronization between optical and SDDS playback, access the **Master SDDS Settings** screen by selecting **Master SDDS** from the **Master** item on the main screen menu bar.

First set the coarse adjustment of frame offset by counting the actual frames of film between the projector's film gate and the LEDs of the DFP-R3000 Reader. You must have at least 32 frames. This adjustment cannot be changed while film is running.

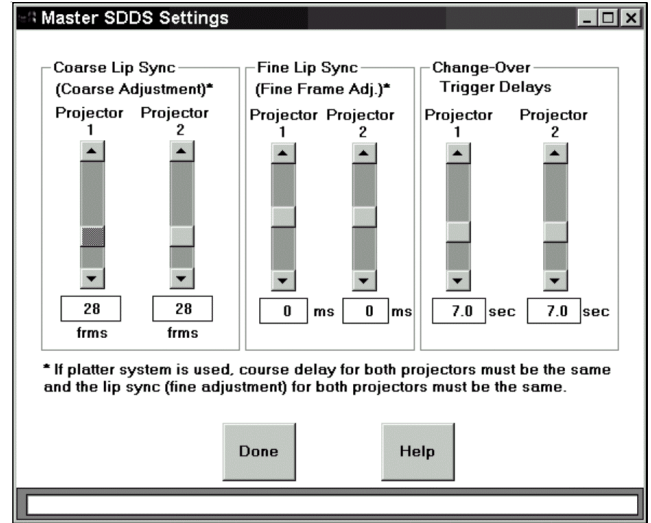

Now adjust the Fine Lip Sync by playing the SDDS Installation reel or a quality, dialog-heavy feature print (not a trailer, which may have loose sync) and comparing optical and digital dialog. Set the fine lip sync to make the two coincident. Do this by plugging headphones into the front panel of the DFP-D3000 and turning the Monitor switch to position 5 (the LCD display will briefly indicate "Lt+Rt/SOURCE_Cch"). The left output will contain the optical center channel and the right output will contain the digital center channel audio. Verify your setting by watching the film from a mid-audience position and check that the dialog synchronization appears to be correct; don't use the projection booth monitor while looking through the booth's port hole or you will retard the sound by about two frames.

The DFP-D3000 allows you to use this same feature to check synchronization of the AUX input signals. This means that if you also have DTS or SRD sources you can check their synchronization against the optical tracks, even though their manufacturers do not offer this capability.

6.14 Setting up Preset configurations. A Preset is a set of retained DFP-D3000 Decoder settings that apply to a particular input signal. These settings are associated with eight numbered switch buttons on the front panel of the Decoder which are used to select inputs. Pressing any of these buttons once will cause the LCD screen to display its current assignments; this is only a display function. Pressing a button twice will select its associated input as the signal source for the Decoder and will also load the corresponding Preset's retained parameters.

Sony recommends that these default Preset assignments be Maintained, but the signal type can be renamed for convenience. For Example, AUX1 could be renamed to DTS, but keep it as Preset 6 unless you have good reason to do otherwise.

Button	Input Signal Type
1	Microphone
2	Non-sync
3	PEC - Academy mono
4	PEC - NR1
5	PEC - NR2
6	AUX1
7	AUX2
8	SDDS

The following parameters are stored in the DFP-D3000 for each Preset:

- Preset name (up to 12 user-entered characters)
- Input signal type (microphone, non-sync, PEC, AUX, or SDDS)
- Speaker output matrix (1 of 16 available matrix options)
- Fallback presets (for presets with AUX or SDDS input formats)
- Preset trim (fader offset for each Preset)
- EQ On/Off switch
- Surround delay On/Off switch
- Surround delay
- Sub-woofer low pass filter frequency
- Fade in time (same for all non-sync presets)

To change these parameters, access the Preset Configuration screen from the Preset Configuration option under the Presets item in the main screen menu bar.

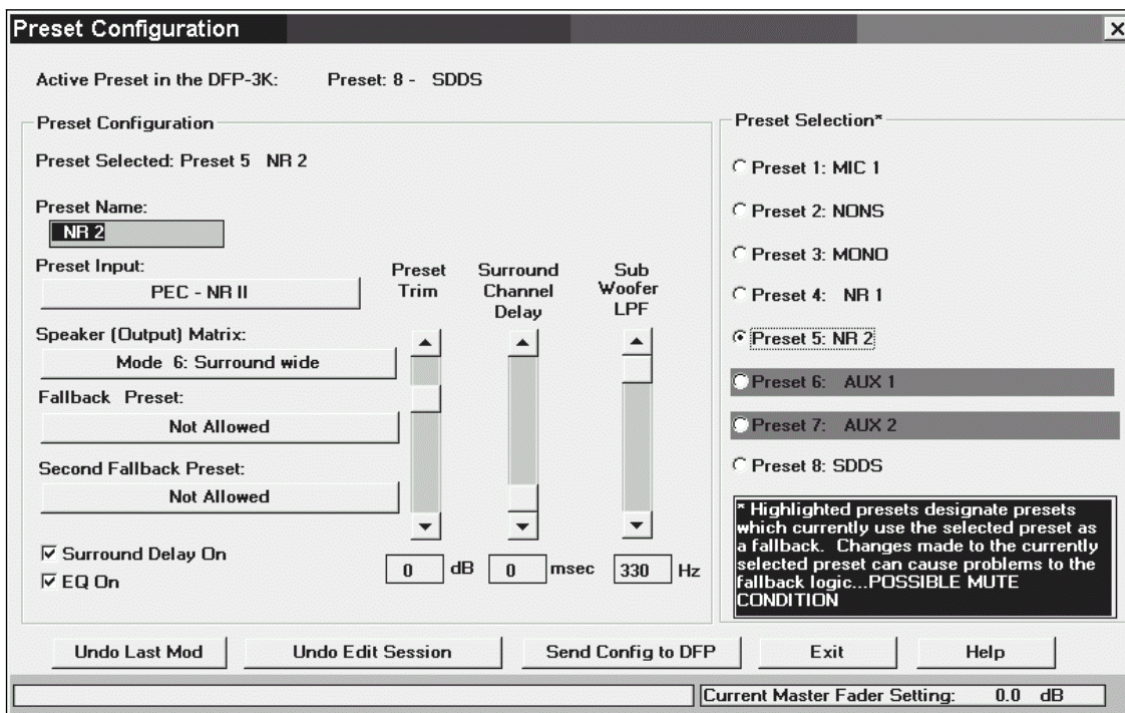

To re-configure a Preset, select the candidate Preset from the list of preset configurations in the **Preset Selection** area of the screen. After selecting the Preset, the various fields in the **Preset Configuration** area will change to reflect its current configuration. If the selected Preset is a fallback assignment for other Presets (in the event their digital data becomes unavailable), such Presets will be highlighted in red in the **Preset Selection** area. If a change is made to the selected Preset which renders it invalid as a fallback for one of its highlighted Presets, the setup software will display a warning and attempt to select another valid Preset to replace the one you have modified. A list of changes will be displayed when the modified Preset's new configuration is sent to the DFP-D3000 Decoder. If you are using firmware v3.0 or later, check with Sony to see if changes have been made to functions available from the Preset Configuration screen.

The **Preset Name** edit box is used to change the name of a preset configuration. Alternate Preset names are entirely up to the user, but cannot exceed 12 characters in length. The Setup Software automatically formats the name to center it in the DFP-D3000 front panel LCD display. To change the input signal type, click on the **Preset Input** edit box and select the signal type from a list that pops up. Sony suggests that you maintain the default selections.

To change the output format for the selected Preset, click on the **Speaker (Output) Matrix** edit box and select from the list that pops up. This list automatically contains only those matrix formats that are allowed for the type of input signal that you have chosen. Here are all the matrix modes and their meanings:

Mode	Name	Meaning
1	SDDS	Eight inputs sent directly to eight outputs
2	SDDS 7.1CH	#1 except LC and RC mixed into L, C, R; SW to SW, LC, and RC outs
3	SDDS 6CH	#1 except LC and RC mixed into L, C, R; SL +SR to SL out; SW to LC and RC
4	SDDS 5.1CH	#1 except LC and RC mixed into L, C, R; SW in to SW out only
5	SDDS 4CH	#1 except LC and RC mixed into L, C, R; SL +SR to SL out; SW to SW only
6	Surround wide	L, R matrix decoded as Lt, Rt, bass extended; to L, C, R, SL = SR, SW
7	Surround narrow	L, R matrix decoded as Lt, Rt, bass extended; to LC, C, RC, SL = SR, SW
8	Stereo wide	L, R in to L, R out; bass extension synthesized and sent to SW
9	Stereo narrow	L, R in to LC, RC out; bass extension synthesized and sent to SW
10	Mono	C in to C out with Academy Filter; SW output off
11	Normal	L, R in to L, R out; SW output off
12	Normal narrow	L, R in to LC, RC out; SW output off
13	Matrix decode W	L, R matrix decoded as Lt, Rt and sent to L, C, R, SL = SR; SW off
14	Matrix decode N	L, R matrix decoded as Lt, Rt and sent to LC, C, RC, SL = SR; SW off
15	Surround	L, R in to SL, SR out; SW output off
16	LRS	L, R matrix decoded as Lt, Rt and sent to L, R with SL = SR; SW off

For the AUX1, AUX2, and SDDS Presets, fallback Presets can be selected. To select a fallback Preset, use the edit button just below the **Fallback Preset** label. If no fallback is permitted for the type of input you have selected, this button will indicate **Not Allowed**. Otherwise, when you click on it, a selection list will pop up which shows all Presets including No Preset, with prohibited Presets grayed out to indicate they are unavailable. The SDDS Preset allows selection of a second fallback preset making it possible for all digital formats to be played automatically with optical as an overall fallback if no digital formats are available on a particular reel. For example, the fallback sequence SDDS → AUX1 → AUX2 → NR2 indicates that if SDDS data becomes unavailable, the DFP-3000 will fall back to its AUX1 input. If neither formats are available, the DFP-3000 will fall back to its AUX2 input. Finally, if no digital formats of any kind are available, the DFP-3000 will fall back to its optical (NR2) input. All this assumes, of course, that the other digital systems are installed and that their logic interfaces are properly wired to the DFP-D3000.

For each Preset, graphic and parametric equalization can be switched on or off, surround delay processing can be switched on or off, the number of seconds of surround delay can be set if surround delay processing is switch on, a volume offset for the preset can be specified, and the sub-woofer low pass filter frequency can be set. To select and set these parameters, use the appropriate control in the **Preset Configuration** area of the screen. If the test signal generator is running, only the preset offset, surround channel delay and EQ on/off switch controls, surround delay setting, and the sub-woofer low pass filter frequency controls are active.

After making modifications to a Preset Configuration, use the **Send Config to DFP** button to send the changes to the DFP-3000 decoder from your connected laptop. Even if the **Send Config to DFP** button is not used, the Setup Software will automatically send the new parameters to the DFP-3000 decoder when the **Exit** button for the **Preset Configuration** screen is clicked. Save these settings as a theatre file when prompted in case they need to be restored to recover from unintended changes, transferred to another processor, or reloaded to the DSP-82 board if it is ever replaced.

6.15 At this point the DFP-3000 system needs only a few final adjustments. The **Preset level trims** can be set according to the preferred methods of each cinema engineer. To access the trim of a Preset from the front panel, select the Preset by pressing its button twice and then press the Down arrow. Adjust the Master Volume control to change the preset trim in order to match the Preset to the SDDS loudness level; when satisfied with the level, press the Up arrow to store the setting and return to normal operation. Some may chose to adjust external non-sync distribution amplifiers to achieve the desired level and leave the DFP-D3000 non-sync trim at 0.0 dB. If the screen has additional digital formats, play a quad format feature and block the LEDs of the various readers and use the DFP-D3000's fallback system to automatically switch between formats, comparing loudness by listening to the booth monitor. This allows checking the fallback wiring as well as the preset level matching. Normally, it is best to use output trims on the other digital players to achieve 85 dB SPL at each speaker in the same manner as was done for the SDDS format with the DFP-D3000 (using pink noise and an SPL meter), but the Preset trims can also be used if convenient. When making this test, blocking the DFP-R3000 reader's LEDs will allow you to confirm operation of the SDDS ACM (Analog Concealment Mode) fallback to optical or other preset.

The **bypass level** setting is made by adjusting two trimmer potentiometers (for Lt and Rt) located at the left of the lower circuit board inside the DFP-D3000. These are adjusted to produce the same output level to L and R when the unit is powered Off while playing a pink noise loop through the optical inputs. Remove two silver screws at the right of the front panel and swing it aside to reach these two trim controls.

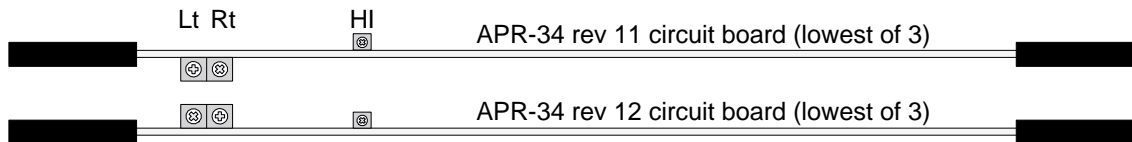

The single **HI** (hearing impaired) output level trim potentiometer is located to the right of the bypass level trim controls and is marked HI on the circuit board. It adjusts the HI output from .7 to 7 V at its rear panel PHONES connector.

7. Overall systems check and listening test.

The basic installation, alignment, and test of the DFP-3000 Cinema Processor System is now complete. Before signing off on the job, the installer will want to play familiar reference films and listen in the house to confirm that all is well. It might also be a good idea to repeat the synchronization test of 6.13 with actual film. Adjust the fine lipsync if necessary; using the front panel for this will require the "SDDS" password.

8. Troubleshooting

Experienced cinema engineers will have their own methods and styles of troubleshooting. Here are some tips that relate to the SDDS format and the DFP-3000 system. Check with Sony Cinema Products for a Tech Note with more details.

Problems with playing SDDS.

First, ensure that the film actually has SDDS tracks on it. These tracks are the light blue or cyan areas at the outside of both rows of sprocket holes. The dark blue spots are very small, but you should be able to see a fine granularity in this area-not just a smooth blue area.

The first indication of problems playing SDDS titles due to poor print quality or dirty optics may be flickering of the film title displayed on the Decoder's LCD display (SDDS Fader Automation must be enabled to display the film title). Clean the Reader optics.

The SYSTEM OK LED on the DFP-D3000 front panel indicates that battery power is OK and that the unit is properly communicating with its Reader. The DATA PRESENT LED will flash if film is running through the Reader at 24 frames/second (+/- 5%) and comes on solidly when SDDS data is being received from the Reader.

Next to the MASTER VOLUME fader is a switch labeled MUTING. If this switch is illuminated, sound does not appear at the outputs. Press it to restore sound output.

The REMOTE LED indicates that the Decoder is being controlled through its serial port, at which time the front panel controls and most of the AUTOMATION connector's inputs are locked out. Be sure your laptop software is "disconnected".

The Reader will turn on its bright red LEDs when the black sprocket roller is turning and it is receiving power through its cable. If the DFP-D3000 is powered and you don't see LEDs on the Reader, check that the Reader cable is plugged in and is not damaged.

The matrix modes described in section 6.14 can be complicated. If you have channels missing, particularly the subwoofer, on a certain Preset, check that you have selected the desired matrix mode for that Preset.

The EXT FADER button on the front panel of the DFP-D3000 enables a remote fader. If this function is active (as indicated by its illuminated switch), the MASTER VOLUME control becomes inoperative and the external fader takes over. Don't use this switch unless an external fader is actually connected or your sound may be muted.

The PROJECTOR LEDs indicate which projector's DFP-R3000 Reader is selected in a changeover environment, using the rear Automation connector pins. Be sure the correct Reader is selected. Optical soundtrack reader selection is also selected at the Automation connector, but has no bearing on these LED indicators.

Problems playing other digital formats.

For other digital systems to play automatically according to fallback settings or when their Preset is selected, their analog audio outputs must be correctly wired to an AUX input and their logic outputs must be correctly wired to the AUTOMATION connector of the DFP-D3000. Basically Pin 34 must be grounded for AUX1 to play and Pin 35 must be grounded to play AUX2, otherwise selecting these Presets will play only their specified fallback sources. The same effect can be achieved in software by selecting "No Fallback" (indicated by *) as the fallback for AUX 1 or 2. This will prevent them from ever going to their fallback presets, but will also preempt selecting optical (NR2) as a fallback in the event their data fails.

If you **lose sound during a show** you can place the DFP-3000 into bypass by turning off its mains power at the front panel; an orange LED in the SELECT switch will come on unless the bypass power supply is not connected. When running off the bypass supply, the Decoder will play in stereo from its optical input, but without noise reduction or matrix decoding. If you lose digital sound for brief periods or if you are unable to play optical soundtracks, the first thing to ensure is that the exciter lamp is working. See Tech Note TN99111901 for help with a forward scan optical reader system.

Use the front panel HEADPHONE output and its MONITOR SELECT switch as a quick troubleshooting aid. The signal source that is selected will be displayed on the LCD screen for five seconds after you move the selector switch to a new position.

In the event you have difficulty.

Sony Cinema Products operates service offices around the world. Contact us for assistance any the following locations:

Sony Cinema Products Corporation Engineering Services Division

West Coast (USA)
10950 W. Washington Boulevard
Culver City CA 90232, USA
Phone: +1 310 244-3484
Fax: +1 310 244-0484
Hours: 8:30am to 5:00pm PST
With 24-hour telephone response
e-mail: sddstech@scpc.sony.com

Sony Cinema Products Corporation Engineering Services Division

East Coast (USA)
123 West Tyron Avenue
Teaneck NJ 07666, USA
Phone: +1 201 833-5778
Fax: +1 201 833-5860
Hours: 8:30am to 5:00pm EST

Sony Cinema Products Europe Engineering Services Division

Europe, Middle East, Africa
25 Golden Square
London W1R 6LU, England
Phone: +44 171 533 1475
Fax: +44 171 533 1590
Hours: 9:00am to 6:00pm GMT

Sony System Service, Tokyo Tokki Service Center

Japan
7-22-17 TOC Building 8F
Nishi Gotanda, Shinagawa-ku
Tokyo, 141-0031, Japan
Phone: +81 3 5436 7510
Fax: +81 3 5436 7519
Hours: 9:00am to 6:00pm JST

9. Appendix

Useful references for installing the system are described here. We also provide useful technical information for installing the DFP-3000 system. Please contact SONY Service Center for more information.

9.1 DFP-D3000 Rear Panel Connector Pin Assignment

SYSTEM (25-pin D-Sub Male)

MONITOR (25-pin D-Sub Male)

AUX1, AUX 2 (25-pin D-Sub Female)

(all according to the THX™ convention)

Pin	Signal
1	Left GND (ground)
2	Left HOT (+, or in-phase of balanced signal)
3	Left Center COLD (–, or out-of-phase of balanced signal)
4	Center GND (ground)
5	Center HOT (+, or in-phase of balanced signal)
6	Right Center COLD (–, or out-of-phase of balanced signal)
7	Right GND (ground)
8	Right HOT (+, or in-phase of balanced signal)
9	Surround Left GND (ground)
10	Surround Left COLD (–, or out-of-phase of balanced signal)
11	Surround Right COLD (–, or out-of-phase of balanced signal)
12	Subwoofer, LFE, COLD (–, or out-of-phase of balanced signal)
13	Subwoofer, LFE, GND (ground)
14	Left COLD (–, or out-of-phase of balanced signal)
15	Left Center GND (ground)
16	Left Center HOT (+, or in-phase of balanced signal)
17	Center COLD (–, or out-of-phase of balanced signal)
18	Right Center GND (ground)
19	Right Center HOT (+, or in-phase of balanced signal)
20	Right COLD (–, or out-of-phase of balanced signal)
21	No connection
22	Surround Right GND (ground)
23	Surround Left HOT (+, or in-phase of balanced signal)
24	Surround Right HOT (+, or in-phase of balanced signal)
25	Subwoofer, LFE, HOT (+, or in-phase of balanced signal)

MIC INPUT (9-pin D-Sub Female)

Pin	Signal
1	Mic 1 GND (ground)
2	Mic 1 HOT (+, or in-phase of balanced signal)
3	No connection
4	Mic 2 GND (ground)
5	Mic 2 HOT (+, or in-phase of balanced signal)
6	Mic 1 COLD (-, or out-of-phase of balanced signal)
7	No connection
8	No connection
9	Mic 2 COLD (-, or out-of-phase of balanced signal)

OPTICAL 1, OPTICAL 2 (9-pin D-Sub Female)

Pin	Signal
1	Left GND (ground)
2	Left HOT (+, or in-phase of balanced signal)
3	No connection
4	Right GND (ground)
5	Right HOT (+, or in-phase of balanced signal)
6	Left COLD (-, or out-of-phase of balanced signal)
7	No connection
8	No connection
9	Right COLD (-, or out-of-phase of balanced signal)

PHONES (9-pin D-Sub Female)

Pin	Signal
1	GND (ground)
2	GND (ground)
3	No connection
4	Headphone Left
5	Headphone Right
6	Mono Hearing Impaired
7	Mono Hearing Impaired
8	No connection
9	Headphone GND (ground)

REMOTE LEVEL CONTROL (Remote Fader) (9-pin D-sub Female)

Pin	Signal
1	Remote potentiometer ground (min gain end)
2	MAIN FADE (input)
3	No connection
4	No connection
5	No connection
6	Remote potentiometer wiper
7	Remote potentiometer DC drive (max gain end)
8	Remote Tally output for LED
9	GND (ground)

AUTOMATION (37-pin D-Sub Female)

Pins in bold type changed after v2.63 firmware.

Pin	Function	Signal
1	Chassis Ground	GND
2	Projector 1 Motor Start	Input: Low = MOTOR 1 RUNNING
3	Master Mute command	Input pulse: Low = MUTE or UNMUTE
4	Preset 1 Select (and tally pulldown)	Input pulse: Low = SELECT
5	Preset 2 Select (and tally pulldown)	Input pulse: Low = SELECT
6	Preset 3 Select (and tally pulldown)	Input pulse: Low = SELECT
7	Preset 4 Select (and tally pulldown)	Input pulse: Low = SELECT
8	Preset 5 Select (and tally pulldown)	Input pulse: Low = SELECT
9	Preset 6 Select (and tally pulldown)	Input pulse: Low = SELECT
10	Preset 7 Select (and tally pulldown)	Input pulse: Low = SELECT
11	Preset 8 Select (and tally pulldown)	Input pulse: Low = SELECT
12	Motor 1	Output tally: Low = MOTOR 1 RUNNING
13	Motor 2	Output tally: Low = MOTOR 2 RUNNING
14, 15	Logic Common	0 V
16, 17	Tally Common	0 V
18	Optical Change Over Command	Input: Low = PEC 2, High = PEC 1
19	Optical Change Over Tally	Output tally: Low = PEC 2 selected
20	Projector 1 Tally	Output tally: Low = SDDS Reader 1 selected
21	Projector 2 Tally	Output tally: Low = SDDS Reader 2 selected
22	Master Mute Tally	Output tally: Low = Master muted
23	Pink Noise	Input: Low = ON
24-29	Reserved	No Connections
30	+5 V	Power
31	+5 V	Power
32	SDDS Data OK (any preset active)	Output pulse: Low = SDDS OK
33	Projector 2 Motor Start	Input: Low = MOTOR 2 RUNNING
34	AUX1 Digital Data OK	Input: Low = Data OK
35	AUX2 Digital Data OK	Input: Low = Data OK
36	SDDS Data not OK	Output pulse: Low = SDDS NG
37	Reserved	No Connection

9.2 DFP-D3000 Input/Output Level

The DFP-D3000 input/output levels are as follows:

AUX input reference level:

The reference level is -8.2 dBu (= 300 mV). The signal level can be increased for other channels only for the Sub Woofer channel input. (Select from 0 dB, +6 dB, +8 dB, +10 dB).

Set this item from the setup software.

Non-Sync input reference level:

Select from +4 dBu reference, -10 dBu reference, and -16 dBu. (Set from the setup software.)

Microphone 1 input reference level:

This input can be used not only as the microphone input but as the line input (monaural) as well.

The level of the microphone input can be adjusted within the range of -20 dBu and -60 dBu.

During line input, the level can be selected from +4 dBu reference, -10 dBu reference, and -16 dBu reference. (Set from the setup software.)

The default values are -50 dBu for the microphone input, and -10 dBu for the line input.

Microphone 2 input reference level:

The level of the microphone input can be adjusted within the range of -20 dBu and -60 dBu (1 dB step).

The default value is -50 dBu.

Phantom power (+48 V) can be supplied for both Microphone inputs 1 and 2.

PEC input reference level:

If A-chain automatic adjustment is performed using the reference film recording the 880 Hz sine wave (film recorded with Dolby Tone) in the DFP-D3000, the DFP-D3000 meter will be set to -20 dB (20 dB below the maximum level of the digital signal processing) when the film reference signal is played back.

Reference level of the digital unit:

20 dB (-20 dBFs) below the maximum level (0 dBFs) of digital signal processing. In digital signal processing, basically -20 dBFs will be directly output to the output if the equalizer level, trim level, etc. have not been adjusted

Audio output level (SYSTEM OUTPUT, MONITOR OUTPUT)

Select from the -16 dB reference or -10 dBu reference. However the system can handle the +4 dBu reference output.

9.3 Changeover Settings

The following signals must be connected to control changeover from the projector.

- Connect the Motor 1 Start signal (output) of the projector to the Pin 1 Proj. 1 motor start terminal (input) of the DFP-D3000 Automation connector. (ON at low level)
- Connect the Motor 2 Start signal (output) of the projector to the Pin 33, Proj. 2 motor start terminal (input) of the DFP-D3000 Automation connector. (ON at low level)
- Connect the Change over command output (gate switching control signal of the projector) of the projector to the Pin 18, C/O CMD IN terminal of the DFP-D3000 Automation connector. (At the Low level, Projector 2 is selected. At the High level, Projector 1 is selected.)
- Connect the Ground signal of the projector to Pins 14 to 17 of the DFP-D3000 Automation connector (Logic common or Tally common)

To control the changeover from the projector, set the time from the start of the motor of the projector to changeover to 7 seconds. Also set the Ramp Time (start up time) to less than 3 seconds (the faster the better).

The following shows the connections for using the DFP-D3000 data detection function for controlling the Dolby surround decoder DA-20 changeover operations.

DFP-D3000 Automation Connector (DB37 F, Cable M)	DA-20 Motor start connector (DB9 F, Cable M)
Pin 12, Motor 1 (start command out)	Pin 1, Motor start Proj. 1 (Input)
Pin 13, Motor 2 (start command out)	Pin 9, Motor start Proj. 2 (Input)
Pin 16, Tally Common	Pin 5, GND

To perform changeover operations, be sure to adjust the lip sync of both projectors. Details of the lip sync adjustment are provided in Section 6.11 of this manual.

The following shows the system configuration and connections of the controller during basic changeover.

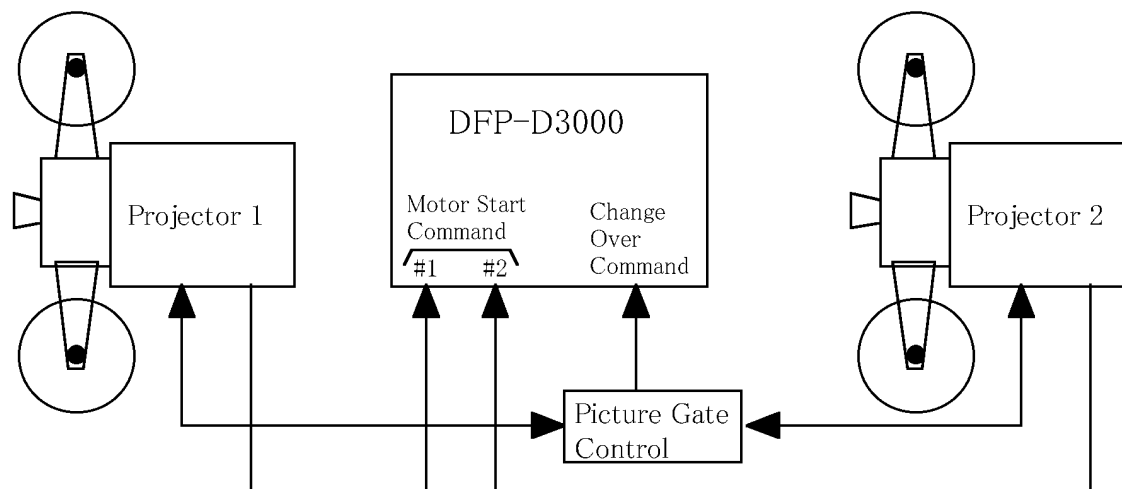

9.4 Settings for using DFP-D3000 as DFP-D2000

The DFP-D3000 operations must be set appropriately using the setup software.

9.4.1 Conditions

When the DFP-D3000 has been added to the existing cinema processor master, **do not turn off the power of the DFP-D3000 while running** the film (including film which does not record SDDS).

No sounds will be output including the existing system if turned OFF.

9.4.2 Connections and Settings when Connecting the Output of an Existing System

1. Connecting the system

Input signals from an existing system to the AUX1 input or AUX2 input for the audio system.

At the same time, connect the theater amplifier to SYSTEM OUT. Also connect the SDDS READER (DFP-D3000) to the DFP-D3000.

Automation connection is required if changeover is to be performed or if switching to other digital formats using the DFP-D3000. The connections are as follows.

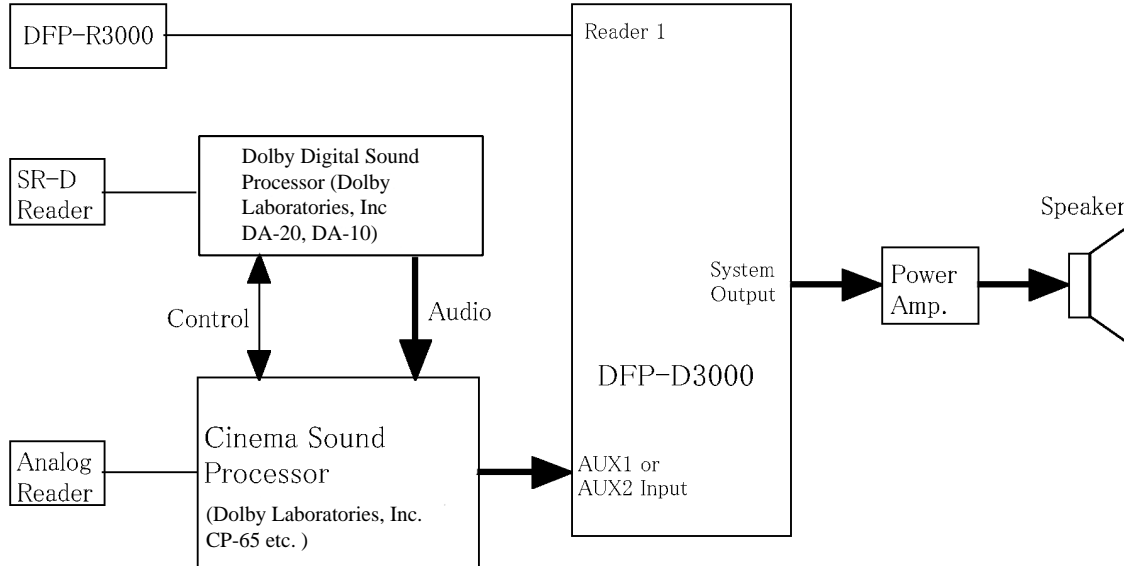

2. Setting of output preset corresponding to AUX1 or AUX2

The following shows an example of the settings of the Preset Configuration screen of the setup software. For this example, signals from the existing system are connected to the AUX1 input.

With this system configuration, set the Fallback of the AUX input to the AUX input itself. (In other words, no Fallback operations. Details are as shown at (1) of the following setting example.) Set the EQ of the AUX input to OFF, and use an equalizer which has been adjusted at the existing system side. Set Surround Delay in the same way. (Details are as shown at (2) of the following setting example.)

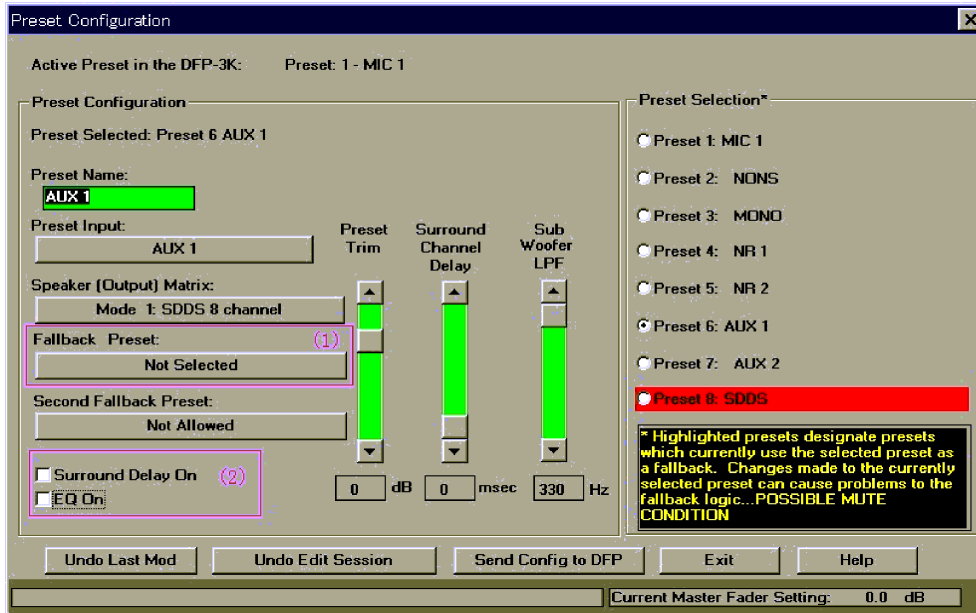

3. Setting the output preset corresponding to SDDS

The following shows an example of the settings of the Preset Configuration screen of the setup software. With SDDS, set the Fallback setting to AUX1. (Details are as shown at (1) of the following setting example.) Like the DFP-D2000, for the inputs corresponding to SDDS, EQ must be turned ON and B-chain and Surround Delay must be set.) (Details are as shown at (2) of the following setting example.)

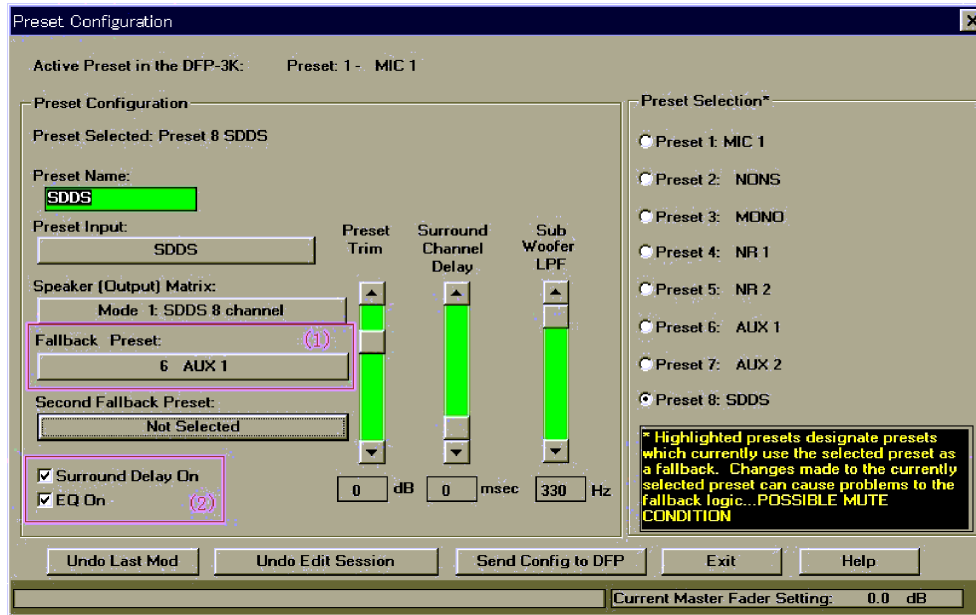

4. Precautions for operations of the above system

- Do not turn off the power of the DFP-D3000 while running the film (including film which does not record SDDS). No sounds will be output including the existing system if turned OFF.
- Adjust the volumes of AUX and SDDS using the Output Offset setting of the Preset Configuration screen to eliminate the difference when AUX and SDDS signals are switched.
- If requiring the same operations as the DFP-D2000, set the preset switches (eight large switches on the front panel) of the DFP-D3000 to preset (Preset 8 at shipment) corresponding to SDDS.
- If the AUX input Fallback setting is not set for some DFP-D3000 setup software versions, in some cases, the Preset Configuration screen cannot be exited. In such cases, set Fallback without using the setup software. Set Fallback by selecting the preset number.

9.4.3 Connections and Settings When Connecting to the Input of the Existing System

1. Connections of the system

For the audio system, connect SYSTEM OUT to the external input of the existing cinema processor.

Connect the SDDS reader (DFP-R3000) to the DFP-D3000.

Automation connection or connection of the AUX input is required if changeover is to be performed or if switching to other digital formats using the DFP-D3000.

The following shows an example of connections.

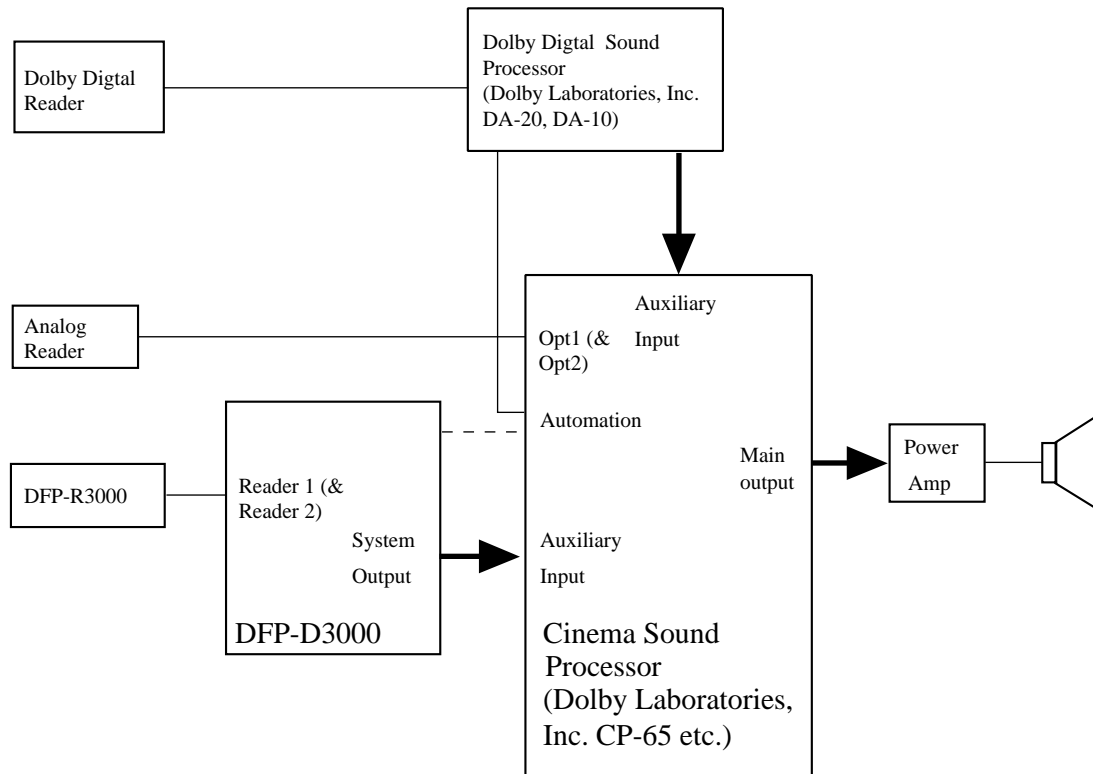

2. Setting of output preset corresponding to SDDS

The following shows an example of the settings of the Preset Configuration of the setup software at this time.

Set the Fallback of the SDDS to "No Fallback". (Refer to (1) in the example of settings screen.)

With this system configuration, do not adjust the B-chain of the DFP-D3000 in order to use the B-chain function of the existing cinema microprocessor. To prevent accidents, set the EQ setting at the Preset settings to OFF. (Refer to (2) in the example of settings screen.) To send signals to the AUX input of the DFP-D3000 from another cinema processor, the AUX input connected to that signal can be selected as the Fallback setting.

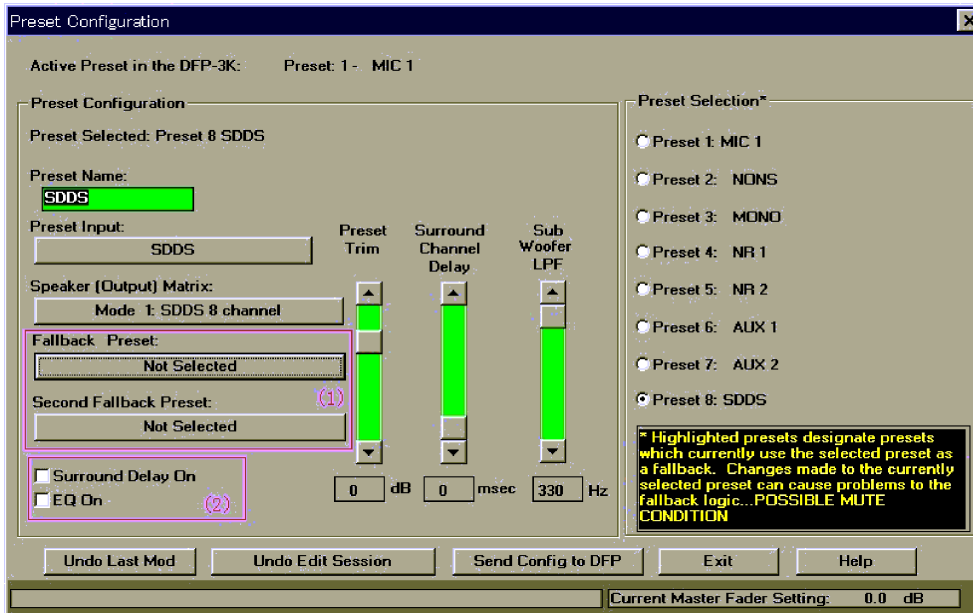

3. Setting of output preset corresponding to AUX1 or AUX2 (Optional)

Set the Fallback of the AUX input to the corresponding AUX input (so that the Fallback function does not operate). Set the AUX input equalizer setting to the same setting as the SDDS format. The following shows an example of the settings of the Preset Configuration screen of the setup software.

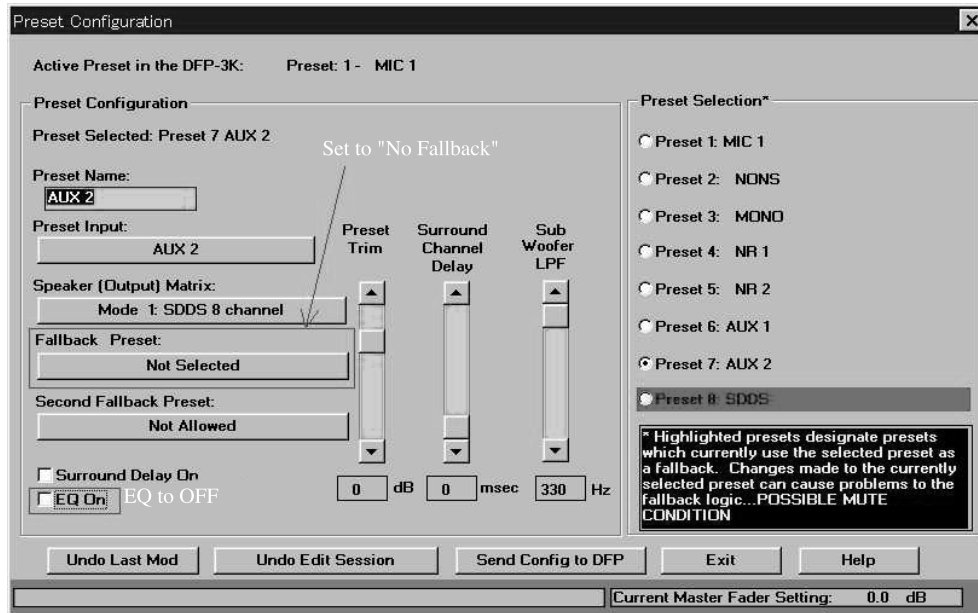

4. Precautions in operations on the above system

- Use the DFP-D3000 master control at 0.0 dB. However, if the signal level of the SDDS input must be controlled at the DFP-D3000 according to the settings of the existing system, adjust the master control.
- Always set the preset switches (eight large switches on the front panel) of the DFP-D3000 to the preset (Preset 8 at shipment) corresponding to SDDS. If film sound processor other than the DFP-D3000 are connected, select the preset corresponding to the external processor or the preset corresponding to the SDDS as necessary.
- In some cases, the Preset Configuration screen cannot be exited if the AUX input Fallback setting is not set for some DFP-D3000 setup software versions. In such cases, set the Fallback function without using the setup software. In this case, set the Fallback by selecting the preset number.

9.5 Description on Connection of DA-20 and DFP-D3000

9.5.1 Outline of System

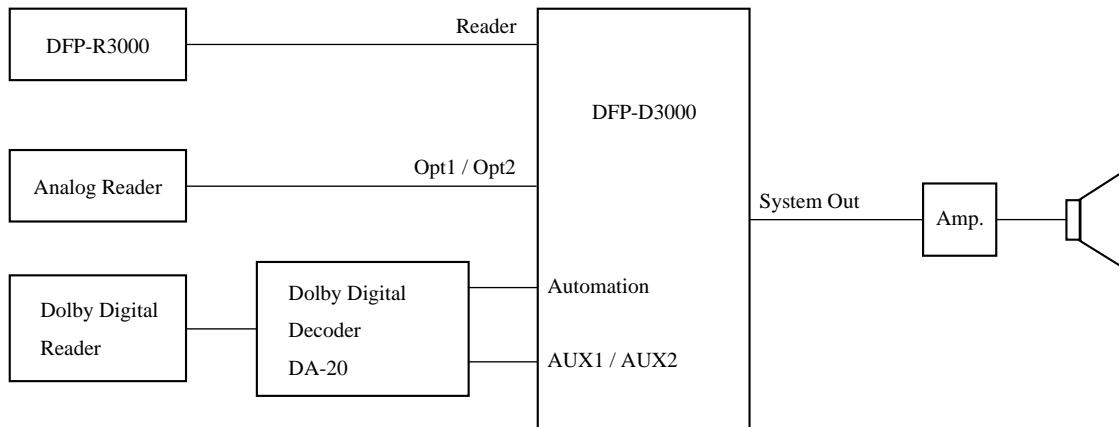

9.5.2 Requirements at SDDS Side

If the DFP-D3000 software is V2.21 or above, the SDDS can be controlled using the method described in this manual.

Check the software version at the Status screen of the DFP-D3000 menu. For details on operating the DFP-D3000 menu, refer to the DFP-D3000 operation manual.

9.5.3 Connection to the DA-20 and Setting the Operation Mode

Using the J8 (CP Audio Conn.) terminal (25-pin D-sub connector) for the Dolby Laboratories DA-20, connect signals from here to the DFP-D3000 AUX INPUT1 or AUX INPUT 2 connector. As the DA-20 unit uses a male connector, prepare a cable with a female connector.

Using the J6 (Sense/Control) terminal (25-pin D-sub connector) as the DA-20 side control signal output terminal, connect signals from here to the DFP-D3000 Automation connector. As the DA-20 unit uses a male connector, prepare a cable with a female connector.

For this connection, the DA-20 operation mode must be set to the **CP-200 mode (position 3)**. The switch for this setting can be accessed without opening the cover. (It is the blue rotary digital switch which can be seen from the front panel operation side.)

9.5.4 Connections for Using the AUX1 Input

Connect Pins 12 (GND) and 14 (sense 0) of the J6 connector of DA20.

Connect Pin 1 (Control 0 output) of the J6 connector of DA20 to Pin 34 (AUX 1 Fallback input, Lip+) of Automation connector.

Connect Pin 12 (GND) of the J6 connector of DA20 to Pin 14 (Logic Common) of the DFP-D3000 Automation connector.

The following shows a specific example of connections. Refer to Section 9.5.6 for details of connections of the audio system connectors

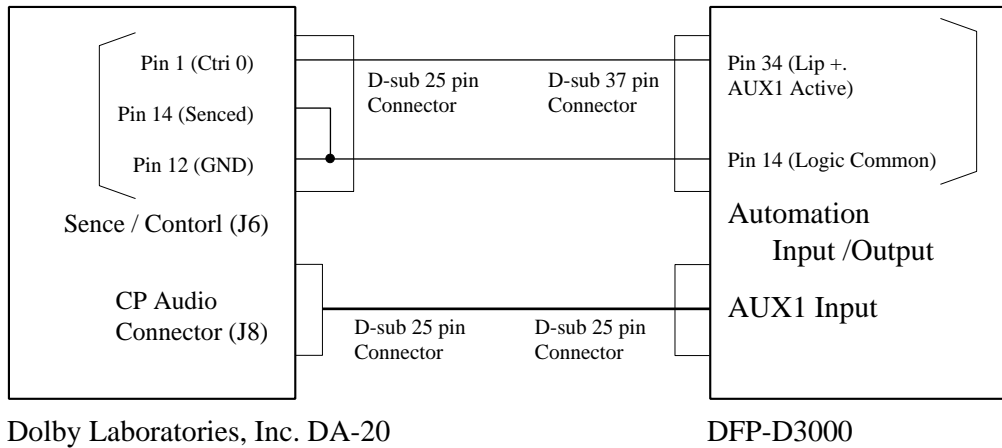

1. Overview of System

DA20
Sense/Control (J6)
25-pin D-Sub (male)

DFP-D3000
Automation
37-pin D-Sub (female)

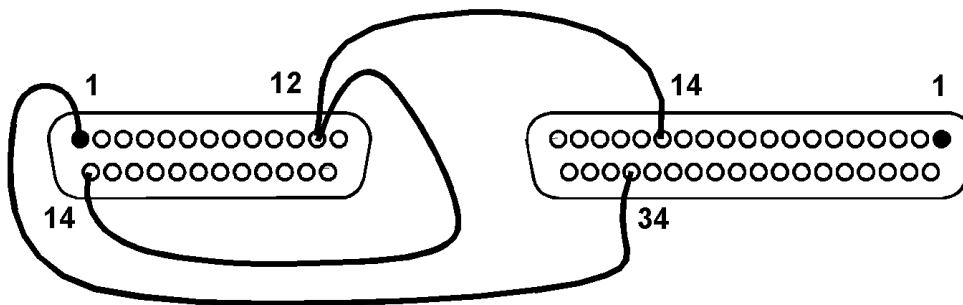

2. Connections of Control System (Including Pin Assignment)

For this connection, open the Preset Configuration screen of the DFP-D3000 setup software, and set the Primary Fallback setting to “NR2” in the preset corresponding to the AUX1 input. (Check the enclosed part of the screen.)

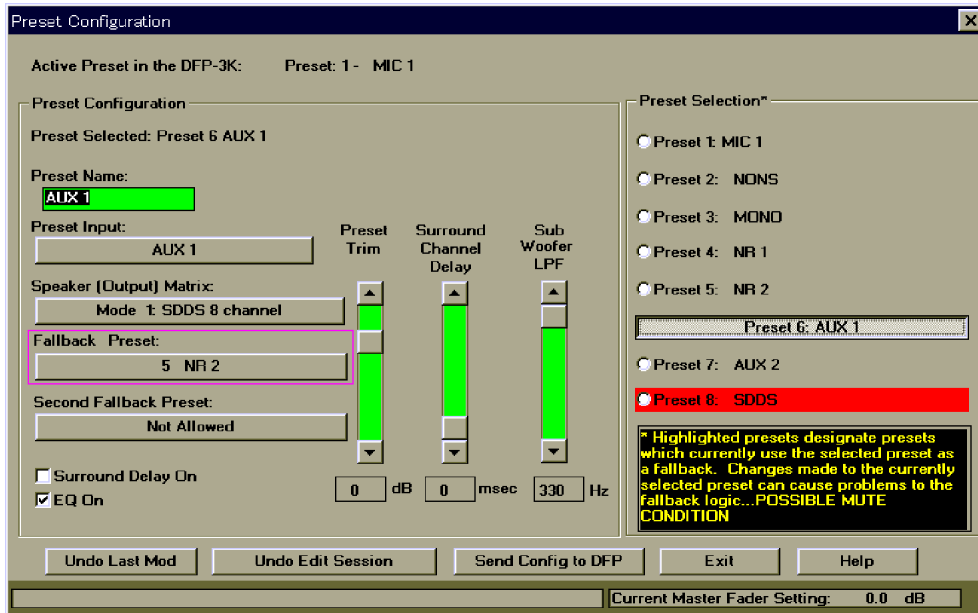

Preset Configuration Screen (When AUX1 is selected)

If Fallback must be performed in the order of AUX1 input and Analog input from SDDS, set the Primary Fallback setting to “AUX1” in the preset corresponding to the SDDS. (Check the enclosed part of the screen.)

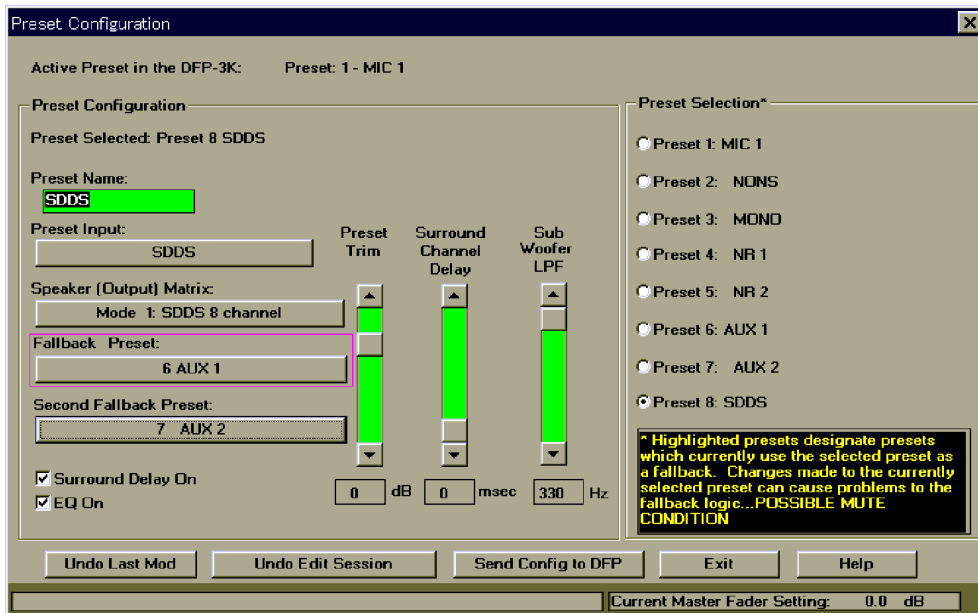

Preset Configuration Screen (When SDDS is selected)

9.5.5 Connections for Using AUX2 Input

Connect Pins 12 (GND) and 14 (sense 0) of the J6 connector of DA20.

Connect Pin 1 (Control 0 output) of the J6 connector of DA20 to Pin 35 (Lip -, AUX1 Fallback input) of Automation connector.

Connect Pin 12 (GND) of the J6 connector of DA20 to Pin 14 (Logic Common) of the DFP-D3000 Automation connector.

The following shows a specific example of connections. Refer to Section 9.5.6 for details of connections of the audio system connectors.

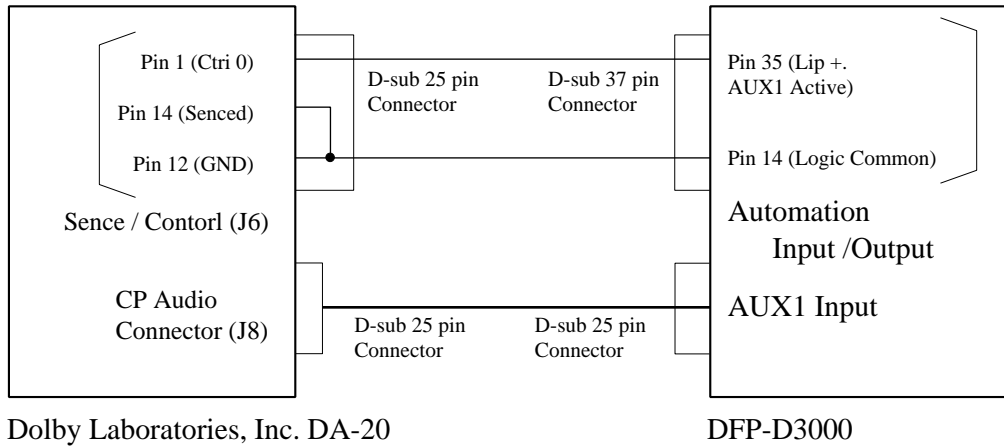

1. Overview of System

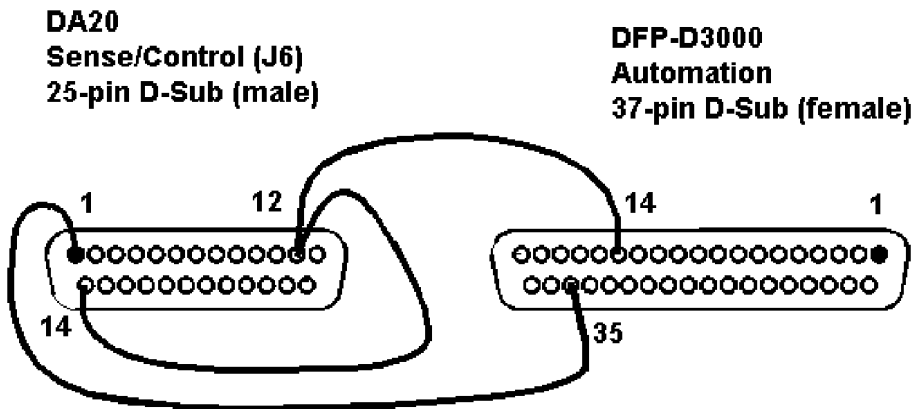

2. Connections of Control System (Including Pin Assignment)

For this connection, open the Preset Configuration screen of the DFP-D3000 setup software, and set the Primary Fallback setting to “NR2” in the preset corresponding to the AUX2 input.

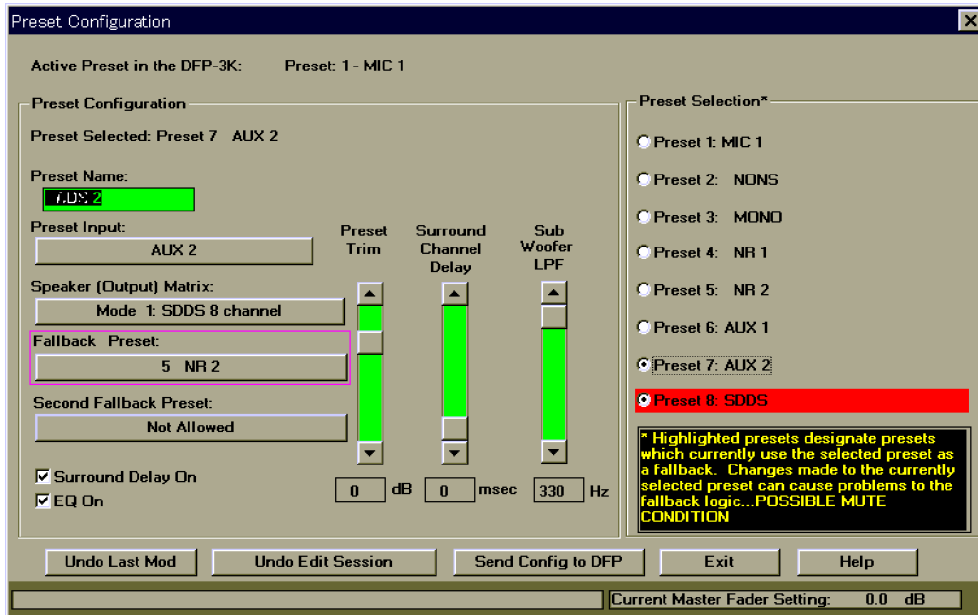

Preset Configuration Screen (When AUX2 is selected)

If Fallback must be performed in the order of AUX2 input and Analog input from SDDS, set the Primary Fallback setting to “AUX2” in the preset corresponding to the SDDS.

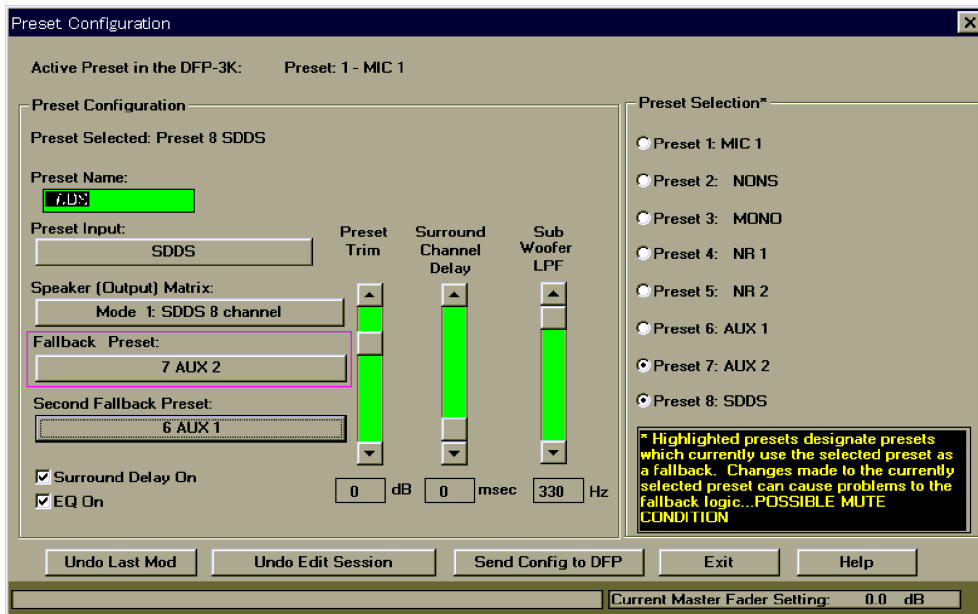

Preset Configuration Screen (When SDDS is selected)

9.5.6 Audio Connecting the DA-20 and DFP-D3000

For details of the connection, refer to the following table.

DFP-D3000 AUX Input 1/2 (DB25, F/Cable M)	DA-20 CP Audio Conn. J8 (DB25 M/Cable F)
1 Left Ground	N.C.
2 Left Hot	14 Left out
3 Left Center Cold	N.A.
4 Center Ground	N.C.
5 Center Hot	20 Center Out
6 Right Center Cold	N.A.
7 Right Ground	N.C.
8 Right Hot	17 Right Out
9 Left Surround Ground	N.C.
10 Left Surround Cold	4 AGND
11 Right Surround Cold	3 AGND
12 Sub Woofer Cold	12 AGND
13 Sub Woofer Ground	N.C.
14 Left Cold	1 AGND
15 Left Center Ground	N.A.
16 Left Center Hot	N.A.
17 Center Cold	8 AGND
18 Right Center Ground	N.A.
19 Right Center Hot	N.A.
20 Right Cold	5 AGND
21 N.C.	N.C.
22 Right Surround Ground	N.C.
23 Left Surround Hot	15 Left Surround Out
24 Right Surround Hot	2 Right Surround Out
25 Sub Woofer Hot	24 Sub Woofer Out

N.A.: No corresponding function. N.C.: Not connected.

Note

All audio grounds must be connected to the shield side of each twisted pair cables at the DFP-D3000.

9.6 Connecting the CP-500 and DFP-3000

When constructing the system by combining the Dolby Laboratories CP-500 and DFP-D3000, as both are equipped with analog pickup interfaces and system control terminals, the functions of both equipments will clash.

It is therefore important to decide which to master depending on ease of constructing the system and uses by the customer. This document describes both the connection when using the DFP-D3000 as the master and the connection when using the CP-500 as the master.

9.6.1 Connecting the DFP-D3000 to the CP-500 with the DFP-D3000 as the master

The advantage of this connection is that the merits of the DFP-D3000 such as high sound quality equalizer circuit and digital signal switching can be put to full use.

The disadvantages on the other hand are; because the CP-500 is unable to output SR-D format OK/NG switching signals at the voltage level, the Fallback control circuit of the DFP-D3000 cannot be used as it is. The same effects can be obtained by using an optional board (cat. 684 card) outputting pulses and performing preset switching of the DFP-D3000 according to the preset switching of the CP-500.

In this case, connect the analog track (PEC) and input from the cinema processor other than the CP-500 to the DFP-D3000, and also connect Fallback if necessary. This means that the CP-500 side is dedicated to playback in the SR-D format.

In this case, the following restrictions apply to both the DFP-D3000 and CP-500.

DFP-D300: Firmware version 2.60 and higher

CP-500: CP-500 units with firmware v1.51 or higher and control board Cat. 684 is installed.

If the software of the DFP-D3000 or CP-500 is older than the above, contact a Dolby Laboratories dealer for the CP-500 and a Sony service center for the DFP-D3000 to upgrade the firmware to the latest version.

1. System Configuration

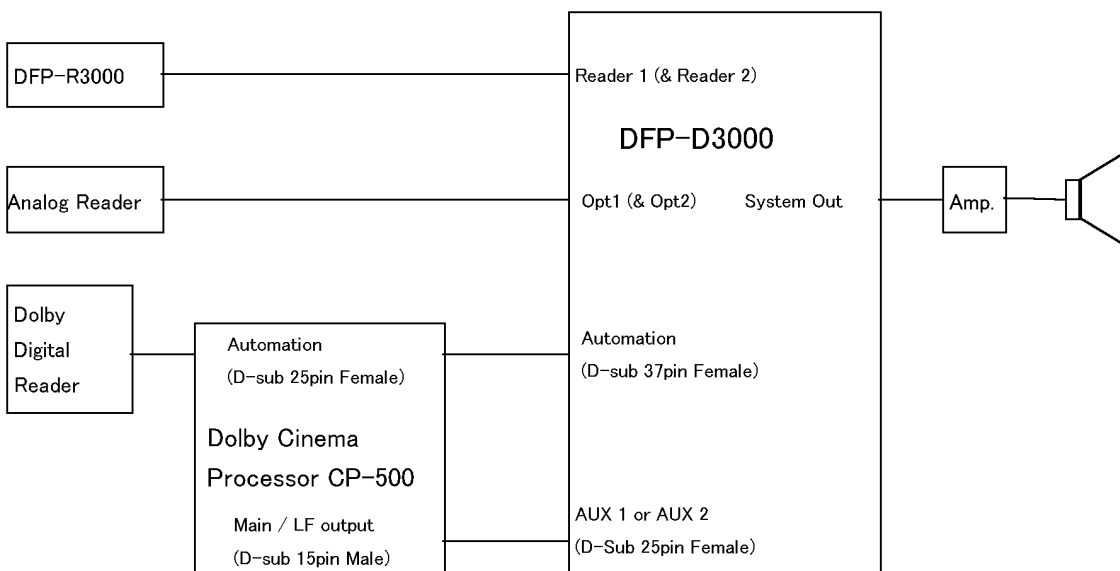

2. Logic wiring connections

DFP-D3000 Automation I/O Connector (D-sub Connector, 37 pin, Female)		CP-500 Automation Connector (D-sub Connector, 25 pin, Female)	
Pin No.	Function	Pin No.	Function
Pin 8	Preset 5 Select (NR2)	Pin 3	SK3 format select (Dolby SR)
Pin 9	Preset 6 Select (AUX 1)	Pin 4	SK4 format select (Dolby Digital)
Pin 14	Logic Common	Pin 12	Ground
Pin 11	Preset 8 Select (SDDS) - Shorted to - SDDS data OK	Pin 6	SK6 format select (Non Sync 1)
Pin 32			
Pin 36	SDDS data not OK	Pin 2	SK2 format select (Dolby A)
Pin 15	Logic Common - Shorted to -		
Pin 34	AUX1 Digital Data OK		

3. Audio wiring connections

DFP-D3000 AUX input 1/2 (D-sub connector, 25 pin, Female)		CP-500 Main / LF output connector (15 pin Phoenix type, Male)	
Pin No.	Function	Pin No.	Function
Pin 1	Left Ground	–	No Connection
Pin 2	Left Hot (+)	1	Left Channel
Pin 4	Center Ground	–	No Connection
Pin 5	Center Hot (+)	5	Center Channel
Pin 7	Right Ground	–	No Connection
Pin 8	Right Hot (+)	3	Right Channel
Pin 9	Left Surround Ground	–	No Connection
Pin 10	Left Surround Cold (–)	8	Signal Ground
Pin 11	Right Surround Cold (–)	10	Signal Ground
Pin 12	Subwoofer Cold (–)	12	Signal Ground
Pin 13	Subwoofer Ground	–	No Connection
Pin 14	Left Cold (–)	2	Signal Ground
Pin 17	Center Cold (–)	6	Signal Ground
Pin 20	Right Cold (–)	4	Signal Ground
Pin 22	Right Surround Ground	–	No Connection
Pin 23	Left Surround Hot (+)	7	Left Surround Channel
Pin 24	Right Surround Hot (+)	9	Right Surround Channel
Pin 25	Subwoofer Hot (+)	11	Subwoofer Channel

Note

The inputs of the DFP-D3000 are professionally balanced, whereas the outputs of the CP-500 are not. Therefore shielded wires should be connected to all DFP-D3000 audio grounds.

4. Procedures for setting up the CP-500

First, confirm that the CP-500 is equipped with firmware version 1.51 or higher.

Next, enable the “Auto Digital” function by referring to the CP-500 Installation Manual. The source format of the “Auto Digital” function should be set to Dolby A (SK2), and the target format to Dolby Digital (SK4). It is crucial that Dolby SR (SK3) is not assigned as a source format of the “Auto Digital” function. These instructions assume that the CP-500 preset is configured for Dolby A on SK2, Dolby SR on SK3, Dolby Digital on SK4 and Non Sync 1 on SK6.

Set the level of all output channels of the CP-500 to the DFP-D3000 AUX Port input reference level. (−8.2 dBu. This value is equivalent to −10 dBV or 300 mV.)

During operation, ensure that the master fader on the CP-500 is disabled or kept at 7.0 at all times.

5. Setting up the DFP-3000

First, confirm that the DFP-D3000 is equipped with firmware version 2.60 or higher.

The DFP-D3000 is configured for SDDS on Preset 8 and that Dolby Digital is on Preset 6 (using the AUX1 input). We recommend that you don't change Preset assignments from the defaults unless there is a strong requirement for doing so. If Preset assignments are to be changed, we recommend setting up the theatre completely and confirming that all is working correctly before making the reassignments.

In this system, set the fallback structure corresponding to the SDDS input (Preset 8) of the DFP-3000 as follows. The Preset Configuration screen of the Setup software will display as follows. ((1) of the following diagram.)

SDDS → [AUX 2] → NR2 (Set the AUX2 input when using the DTS, etc.)

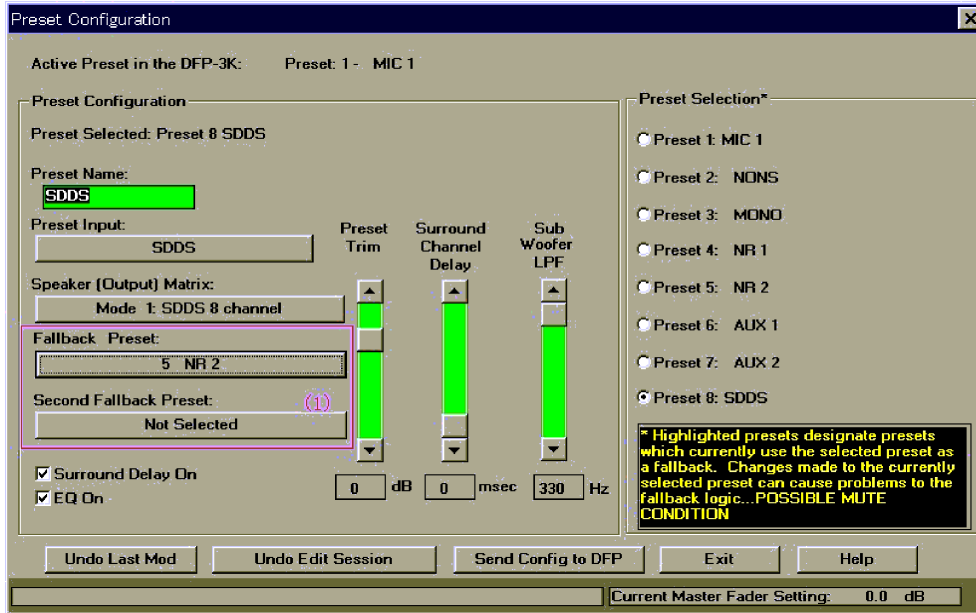

If equalizer adjustments for B-chain have been performed on the CP-500, set the equalizer setting of the corresponding preset (Preset 6) of the DFP-D3000 to “OFF”. In the same way, if the Surround Delay is set at the CP-500 side, set the DFP-D3000 Surround Delay to “OFF”. The Preset Configuration screen of the Setup software will display as follows. ((2) of the following diagram.)

Generally, as the equalizer and delay quality of the DFP-3000 are better than CP-500, use the DFP-3000. The preset fallback setting corresponding to the CP-500 can be left at the default setting. (Because it is fixed to prevent hardware fallback.)

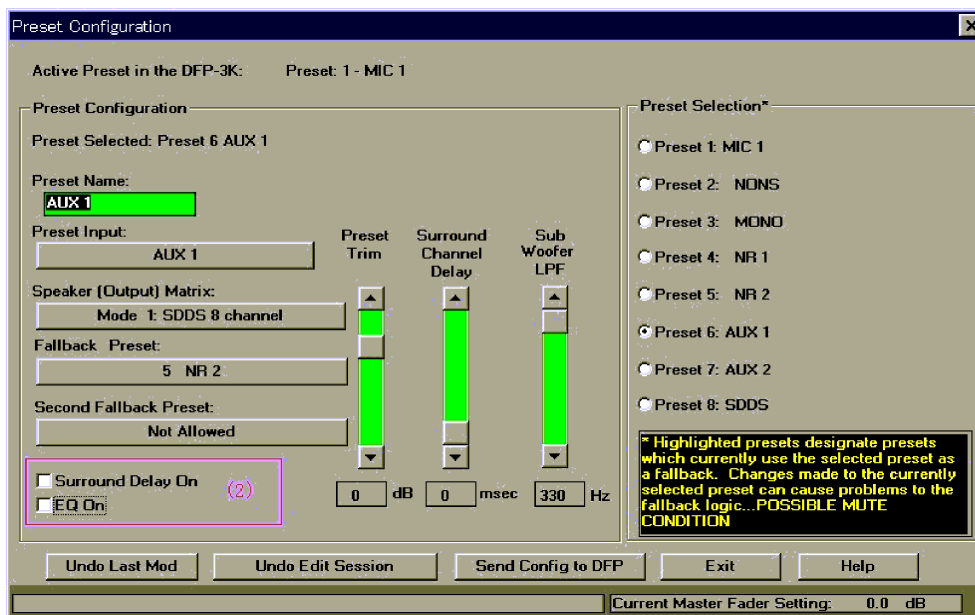

6. Using as the changeover system

When using the system combining the DFP-D3000 and CP-500 in the changeover format, it is necessary to supply the motor start pulse and change over command signals for the CP-500 as well. Therefore, add the following signals to the control signal line and connect the cables.

Projector	DFP-D3000 Automation I/O Connector (D-sub Connector, 37pin, Female)		CP-500 Motor Start Connector (D-sub Connector, 9pin, Female)	
Signal	Pin No.	Function	Pin No.	Function
Projector 1 Motor Start	Pin 12	Motor 1	Pin 1	Motor Start Projector 1
Projector 2 Motor Start	Pin 13	Motor 2	Pin 9	Motor Start Projector 2
Picture Gate Select	Pin 19	C/O command, tally	Pin 3	Change Over Relay
Common	Pin 16	Tally Common	Pin 5	GND

9.6.2 Connecting the DFP-3000 to the CP-500 with the CP-500 as master.

When using the CP-500 as the master, use the DFP-D3000 for only the playback of the SDDS. This setting has the following problems.

1. The CP-500 input and output are unbalanced while those of the DFP-D3000 are balanced, therefore compared to the CP-500, effects of external noises are less.
2. The powerful theatre control features and easy setup of the A- and B-chain of the DFP-3000 will be disabled.
3. Channel level trims of the CP-500 will affect the SDDS channels.
4. The CP-500 analog bass and treble controls will also affect SDDS playback.

However, when using the CP-500 as the master in consideration of the ease of operations, set the CP-500 and DFP-D3000 as follows.

1. System configuration

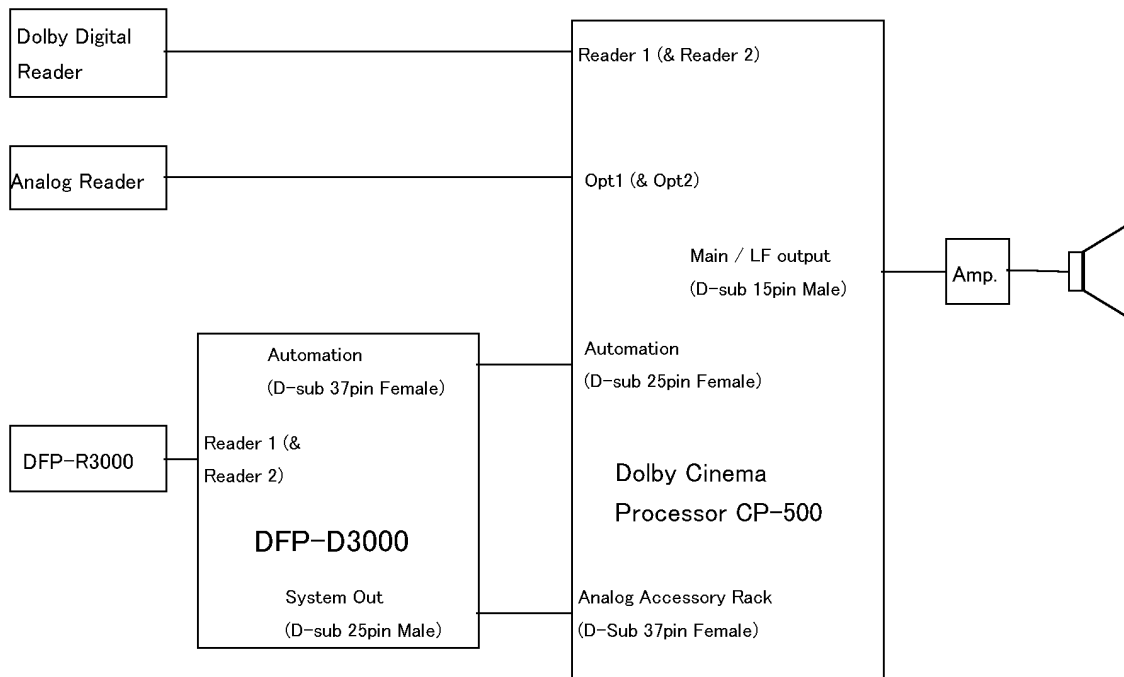

2. Logic wiring connections

DFP-D3000 Automation I/O Connector (D-sub connector, 37 pin, Female)		CP-500 Automation Connector (D-sub connector, 25 pin, Female)	
Pin No.	Function	Pin No.	Function
Pin 16	Tally Common	Pin 12	Signal Ground
Pin 32	SDDS Data OK - Wired to -	Pin 6	SK6 Format Select Input (Note.)
Pin 11	Preset 8 select		
Pin 36	SDDS Data not OK	Pin 4	SK4 Format Select Input (Note.)

Note

These connections are valid only if the Dolby Digital format is assigned to SK4 and SDDS (User 1 or higher) is assigned to SK 6 on the CP-500. On the DFP-D3000, SDDS must be assigned to Preset 8.

3. Audio wiring connections

DFP-D3000 System Output connector (D-sub connector, 25 pin, Male)		CP-500 Main/LF output connector (D-sub connector, 37 pin, Female)	
Pin No.	Function	Pin No.	Function
Pin 1	Left Ground	–	No Connection
Pin 2	Left Hot (+)	7	X10 (Left)
Pin 4	Center Ground	–	No Connection
Pin 5	Center Hot (+)	6	X11 (Center)
Pin 7	Right Ground	–	No Connection
Pin 8	Right Hot (+)	5	X12 (Right)
Pin 9	Left Surround Ground	–	No Connection
Pin 10	Left Surround Cold (–)	26	Signal Ground
Pin 11	Right Surround Cold (–)	27	Signal Ground
Pin 12	Subwoofer Cold (–)	28	Signal Ground
Pin 13	Subwoofer Ground	–	No Connection
Pin 14	Left Cold (–)	36	Signal Ground
Pin 17	Center Cold (–)	34	Signal Ground
Pin 20	Right Cold (–)	29	Signal Ground
Pin 22	Right Surround Ground	–	No Connection
Pin 23	Left Surround Hot (+)	2	X11 (Left Surround)
Pin 24	Right Surround Hot (+)	3	X12 (Right Surround)
Pin 25	Subwoofer Hot (+)	4	X13 (Subwoofer)

Note

The outputs of the DFP-3000 are professionally balanced, whereas the inputs of the CP-500 are not. Therefore all DFP-D3000 audio grounds should be connected to shielded wires.

4. Setting up the CP-500

On the CP-500, make a custom user format derived from Format 5 (SR). Then change the settings of the CP-500 as follows. (For details, refer to the instruction manual of the CP-500.)

- (1) After copying existing format (5), press “Accessory Rack” and select “Xmit/Receive enable”
- (2) Press “Channel Mute”. Two cross point tables appear.
- (3) Open all cross points.
- (4) The first cross point table is called “Accessory rack”. Connect the corresponding channels. (For example, connect the input Left Channel to the output Left Channel. Set other channels in the same way.)
- (5) The second cross point table (named “Normal”) should be left open.
- (6) Save the user format as User 1 (or another name) and configure the format selector so that this user format is assigned to SK6.

With the Automation wiring specified above, if SDDS data is normally detected even once, the DFP-D3000 will send signals to the CP-500 SK6 so that SDDS input sounds are output.

The user format set this way is not set as the source of the audio digital function of the CP-500. Therefore each time films on more than two digital formats are played back, the SDDS playback is interrupted, and the SR-D format sound is played back.

5. Audio input/output level adjustments

Since the channel output adjustment and output bass and treble adjustments of the CP-500 is done on the output board (in the analog domain), these settings will also affect SDDS. Therefore, adjust the B-chain of the CP-500 prior to the B-chain of the DFP-D3000.

To obtain an optimum gain structure, select -10 dBu reference as the DFP-D3000 reference output level, and increase the channel level trims to approximately $+2$ dB to match the 300 mV reference input level of the CP-500.

With this set-up, the master fader of the CP-500 will not affect the playback levels for formats played through the DFP-D3000 and vice versa.

6. DFP-D3000 settings

Basically, as the DFP-D3000 is used only for SDDS reading, use it at the shipment settings. Do not adjust the DFP-D3000 equalizer and surround delay settings, but set them at the CP-500. It is recommended that the DFP-D3000 SDDS Preset (Preset 8) EQ and Surround Delay settings are set to OFF.

7. Using as a changeover system

When using the system combining the DFP-D3000 and CP-500 in the changeover format, it is necessary to supply the motor start pulse and change over command signals for the CP-500 as well. Therefore, add the following signals to the control signal line and connect the cables.

Projector	DFP-D3000 Automation I/O Connector (D-sub Connector, 37pin, Female)		CP-500 Motor Start Connector (D-sub Connector, 9pin, Female)	
Signal	Pin No.	Function	Pin No.	Function
Projector 1 Motor Start	Pin 12	Motor 1	Pin 1	Motor Start Projector 1
Projector 2 Motor Start	Pin 13	Motor 2	Pin 9	Motor Start Projector 2
Picture Gate Select	Pin 19	C/O command, tally	Pin 3	Change Over Relay
Common	Pin 16	Tally Common	Pin 5	GND

9.7 Connecting the DTS-6, DTS-6D and DFP-D3000

9.7.1 Outline of System

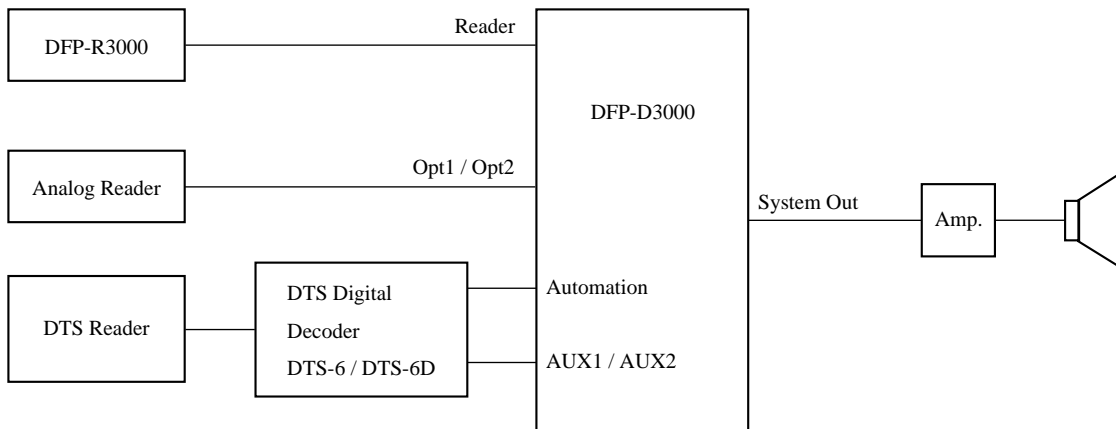

9.7.2 Requirements of SDDS Side

The DFP-D3000 software version must be more than 2.21. You can check the software version at the Status screen of the DFP-D3000 menu. For details, refer to the DFP-D3000 operation manual.

9.7.3 Connecting the DTS Processor DTS-6

DTS-6 side output: Use the DTS-6 STEREO terminal (15-pin D-sub connector).

Notes

1. No DTS Automation interface board is necessary.
2. The DTS output board operation mode in the DTS-6 system must be set to the CP-200 mode. (Set using two DIP switches. For details, refer to the DTS-6 manual.)

1. Connecting DTS-6 to the AUX1 Input Terminal

Connect Pins 13 (DTS S/W Enable Output) of the DTS-6 STEREO connector and 34 (Lip+, AUX1 Fallback Input) of the DFP-D3000 Automation connector.

Connect Pin 8 (GND) of the DTS-6 STEREO connector and Pin 14 of the DFP-D3000 Automation connector (Logic Common). The following shows a specific example of connections.

For audio signals, connect an adapter (DTS-6 option) for connecting the DTS-6 to the CP-500 to the JM21 connector of the DTS-6, and use the D-Sub 25-pin of this adapter to connect the AUX1 connector of the DFP-D3000. Refer to Section 9.7.5 of this manual for details of the connector pin assignment.

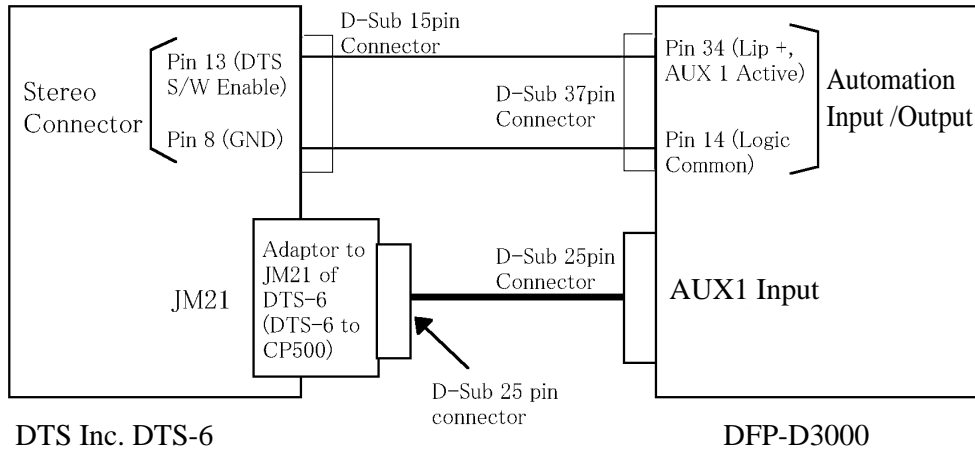

1. Overall System Configuration

DTS-6
"Stereo" connector
15-pin D-Sub (male)

DFP-D3000
Automation connector
37-pin D-Sub (female)

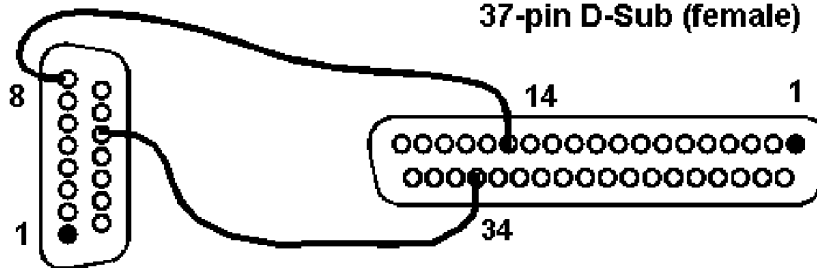

2. Connection of Controller (Including Pin Assignment)

For this connection, open the Preset Configuration screen of the DFP-D3000 setup software, and set the Primary Fallback setting to “NR2” in the preset corresponding to the AUX1 input. (Check the enclosed part of the screen.)

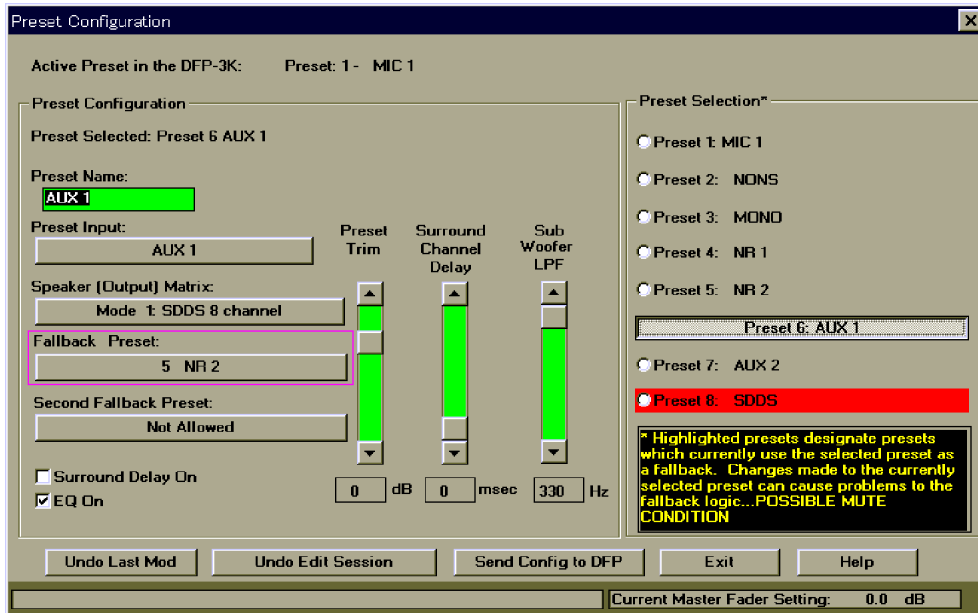

Preset Configuration Screen (When AUX1 is selected)

If fallback must be performed in the order of AUX1 input and Analog input from SDDS, set the Primary Fallback setting to “AUX1” in the preset corresponding to the SDDS. (Check the enclosed part of the screen.)

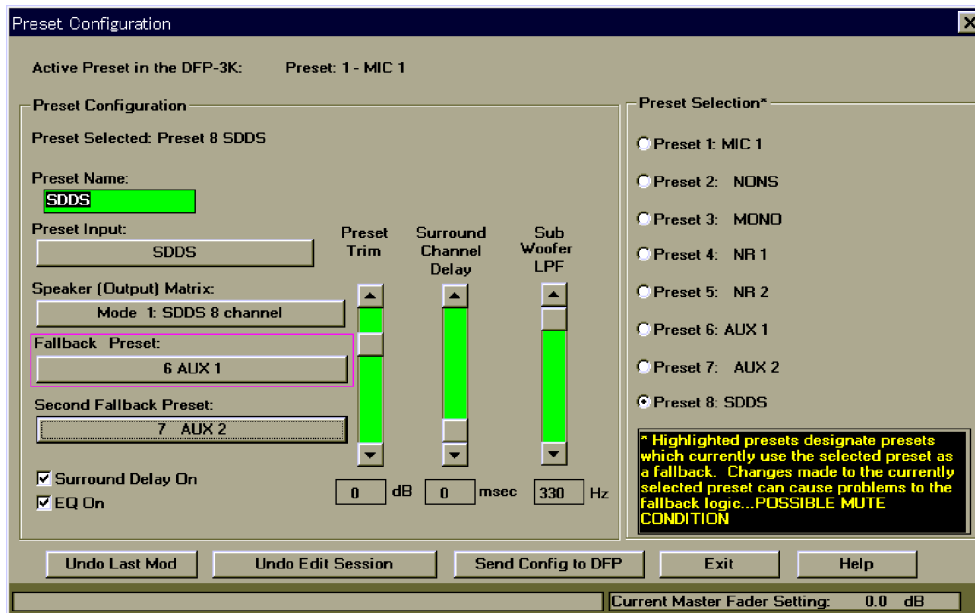

Preset Configuration Screen (When SDDS is selected)

2. Connecting DTS-6 to the AUX2 Input Terminal

Connect Pin 13 (DTS S/W Enable Output) of the DTS-6 STEREO connector and Pin 35 (Lip-, AUX2 Fallback input) of the DFP-D3000 Automation connector.

Connect Pin 8 (GND) of the DTS-6 STEREO connector and Pin 14 of the DFP-D3000 Automation connector (Logic Common). The following shows a specific example of connections.

For audio signals, connect an adapter (DTS-6 option) for connecting the DTS-6 to the CP-500 to the JM21 connector of the DTS-6, and use the D-Sub 25-pin of this adapter to connect the AUX1 connector of the DFP-D3000. Refer to Section 9.7.5 of this manual for details of the connector pin assignment.

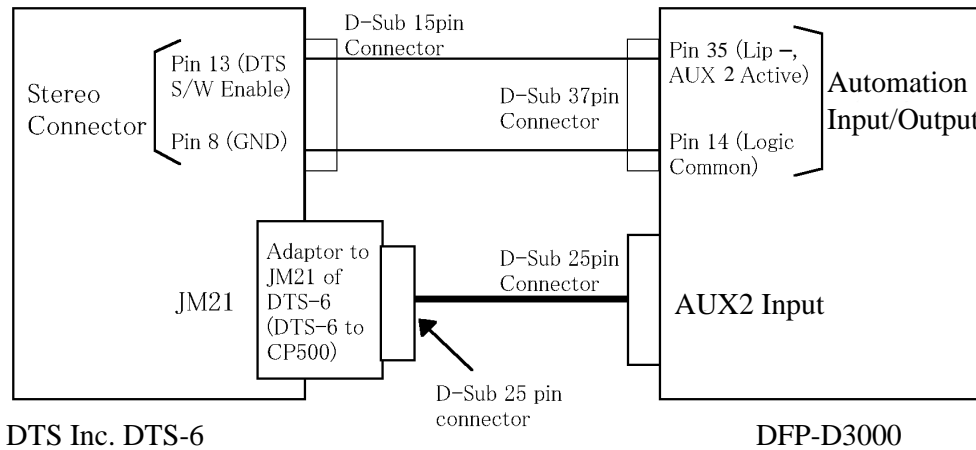

1. Overall System Configuration

DTS-6

"Stereo" connector
15-pin D-Sub (male)

DFP-D3000

Automation connector
37-pin D-Sub (female)

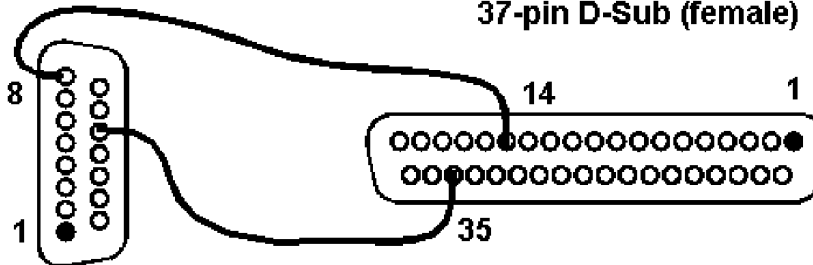

2. Connection of Controller (Including Pin Assignment)

For this connection, open the Preset Configuration screen of the DFP-D3000 setup software, and set the Primary Fallback setting to “NR2” in the preset corresponding to the AUX2 input.

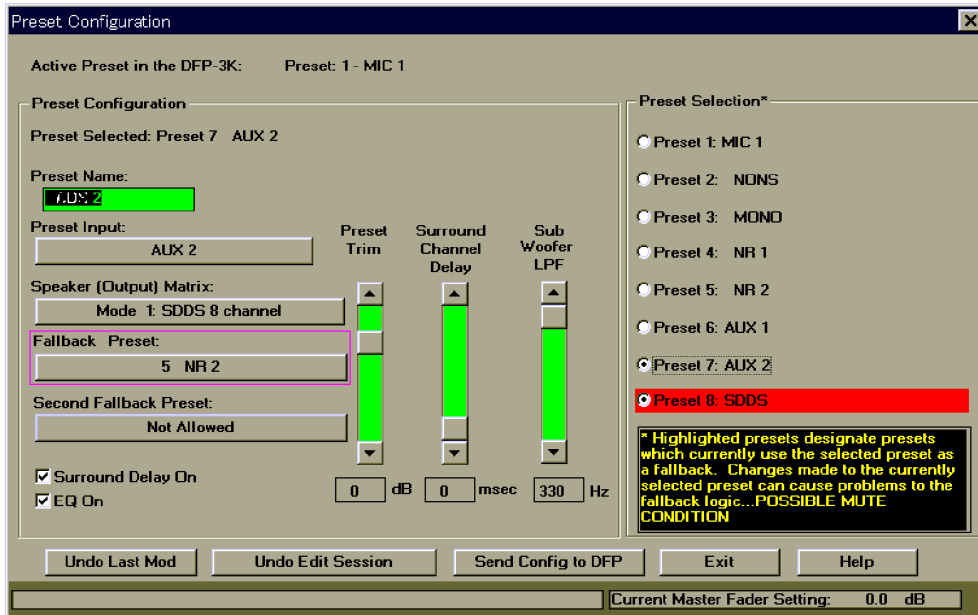

Preset Configuration Screen (When AUX2 is selected)

If fallback must be performed in the order of AUX2 input and Analog input from SDDS, set the Primary Fallback setting to “AUX2” in the preset corresponding to the SDDS.

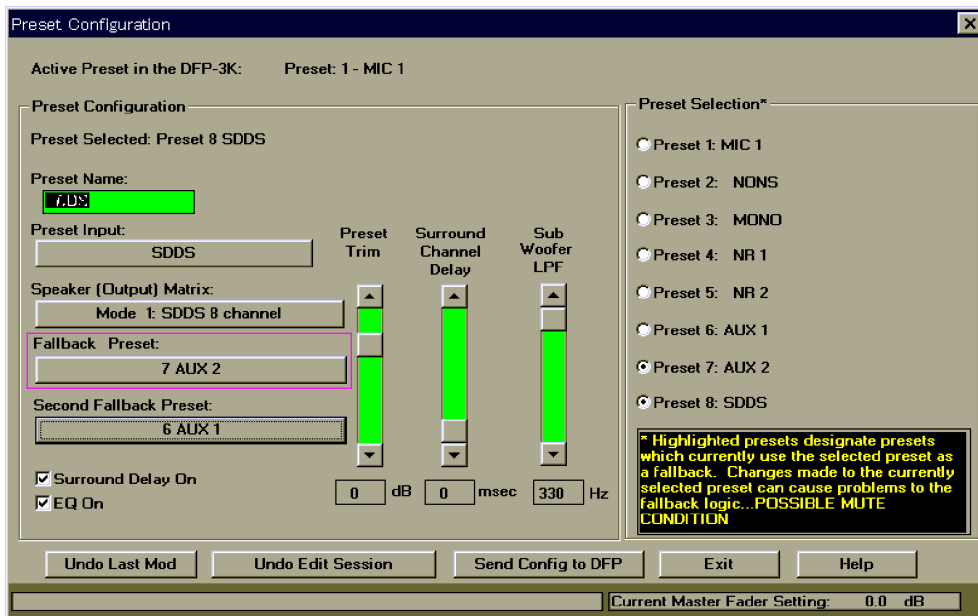

Preset Configuration Screen (When SDDS is selected)

9.7.4 Connection of Control Signals from DTS Processor DTS-6D

DTS6D side output: Use the DTS-6D Automation terminal (25-pin D-sub connector).
There is no need to use the DTS Automation interface board.

The following shows an example of system control system connections.

1. Connecting the DTS-6D to the AUX1 input terminal

Connection when using the AUX1 terminal

Connect Pin 10 (GND when Digital output) of the DTS-6D Automation connector and Pin 34 (Lip+, AUX1 Fallback input) of the DFP-D3000 Automation connector.

Connect Pin 13 (GND) of the DTS-6 Automation terminal and Pin 14 of the DFP-D3000 Automation connector (Logic Common). The following shows a specific example of connections.

For audio signals, use a DTS-6D analog output connector (D-sub, 25 pin) to connect the AUX1 of the DFP-D3000. Refer to Section 9.7.5 of this manual for details of the connector pin assignment.

Note

When connecting the DTS-6D to the DFP-D3000, the DTS Automation Interface board is not necessary.

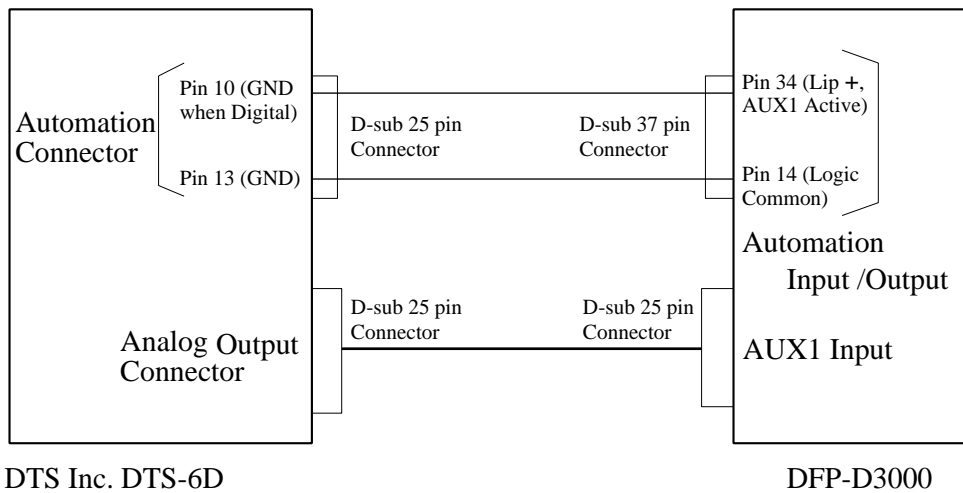

1. Overall System Configuration

DTS-6D
Automation connector, J1
25-pin D-Sub (male)

DFP-D3000
Automation connector
37-pin D-Sub (female)

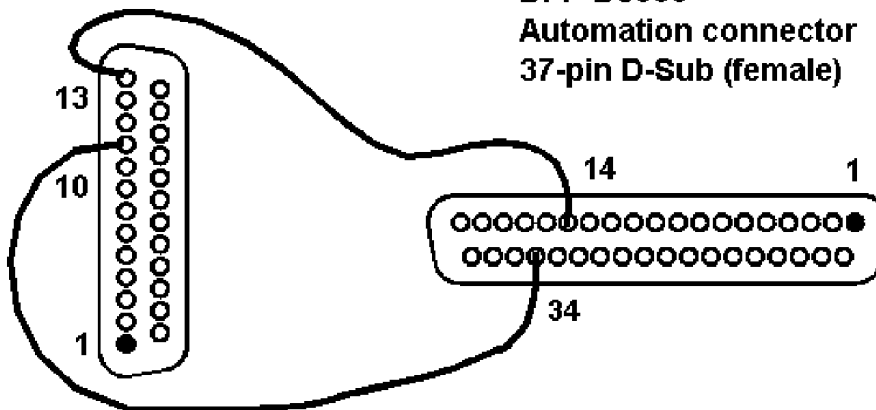

2. Connection of Controller

For this connection, open the Preset Configuration screen of the DFP-D3000 setup software, and set the Primary Fallback setting to “NR2” in the preset corresponding to the AUX1 input. (Check the enclosed part of the screen.)

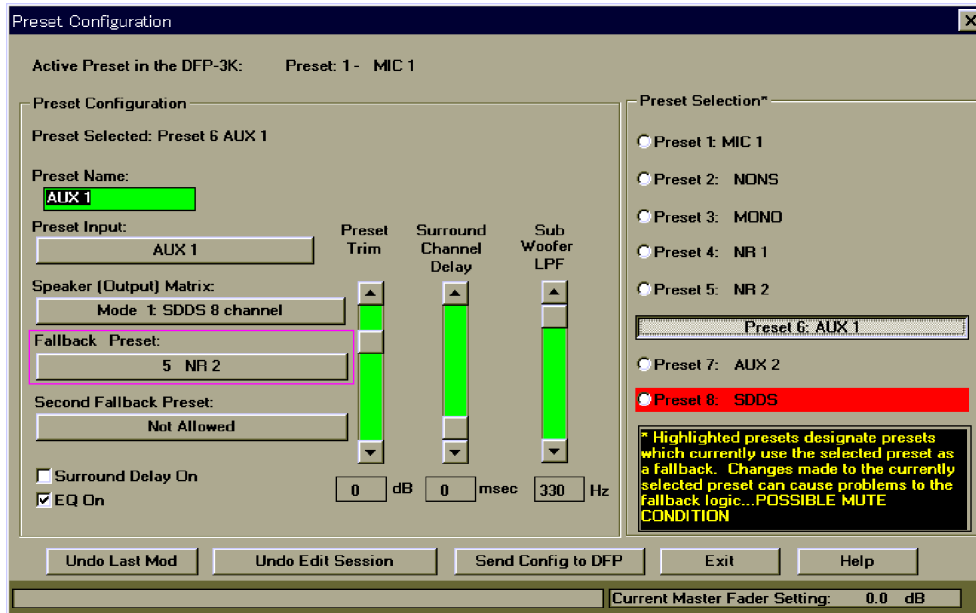

Preset Configuration Screen (When AUX1 is selected)

If fallback must be performed in the order of AUX1 input and Analog input from SDDS, set the Primary Fallback setting to AUX1 in the preset corresponding to the SDDS. (Check the enclosed part of the screen.)

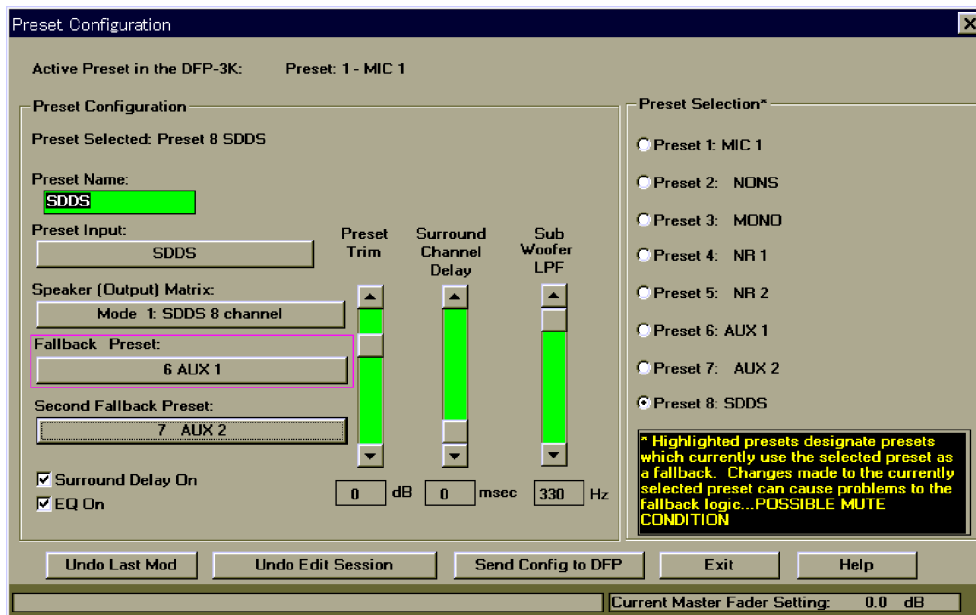

Preset Configuration Screen (When SDDS is selected)

2. Connecting the DTS-6D to the AUX2 input terminal

Connection when using the AUX2 terminal

Connect Pin 10 (GND when Digital output) of the DTS-6D Automation connector and Pin 35 (Lip-, AUX2 Fallback input) of the DFP-D3000 Automation connector.

Connect Pin 13 (GND) of the DTS-6D Automation terminal and Pin 14 of the DFP-D3000 Automation connector (Logic Common). The following shows a specific example of connections.

For audio signals, use a DTS-6D analog output connector (D-sub, 25 pin) to connect the AUX2 of the DFP-D3000. Refer to Section 9.7.5 of this manual for details of the connector pin assignment.

Note

When connecting the DTS-6D to the DFP-D3000, the DTS Automation Interface board is not necessary.

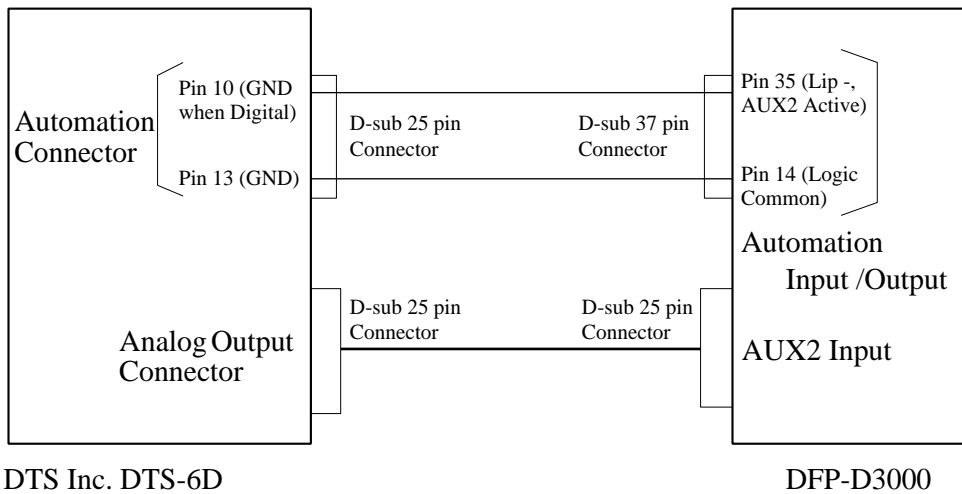

1. Overall System Configuration

DTS-6D
Automation connector, J1
25-pin D-Sub (male)

DFP-D3000
Automation connector
37-pin D-Sub (female)

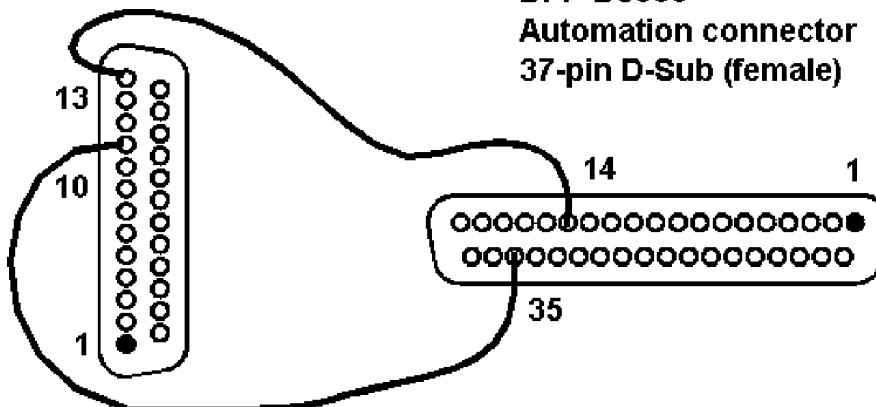

2. Connection of Controller

For this connection, open the Preset Configuration screen of the DFP-D3000 setup software, and set the Primary Fallback setting to “NR2” in the preset corresponding to the AUX2 input.

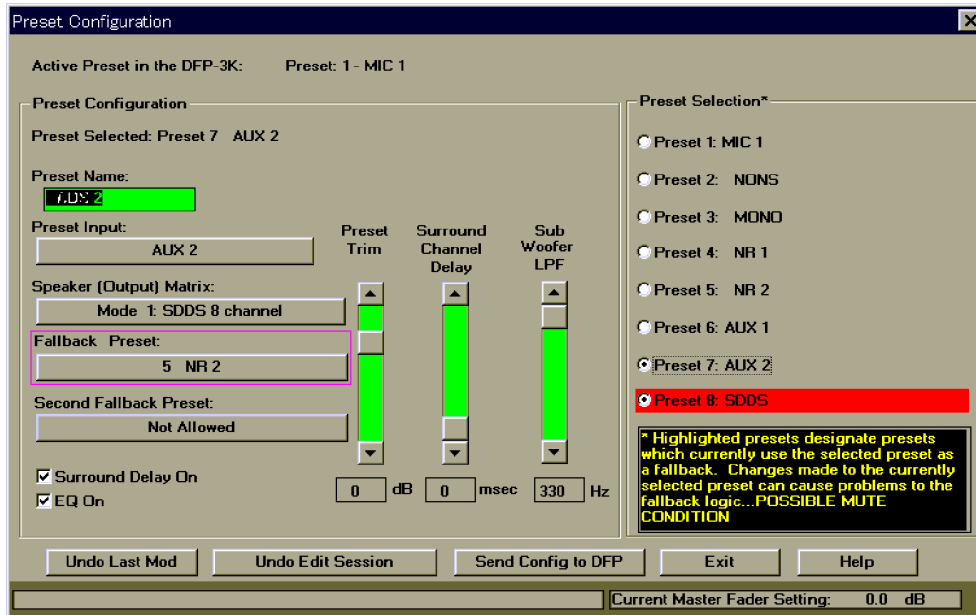

Preset Configuration Screen (When AUX2 is selected)

If fallback must be performed in the order of AUX2 input and Analog input from SDDS, set the Primary Fallback setting to “AUX2” in the preset corresponding to the SDDS.

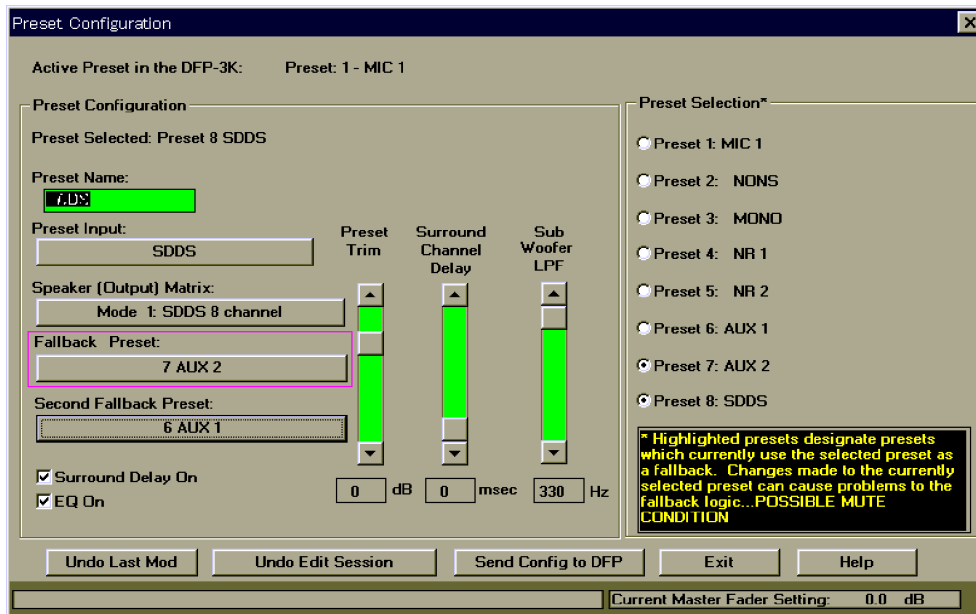

Preset Configuration Screen (When SDDS is selected)

9.7.5 Audio Connecting the DTS-6, DTS-6D and DFP-D3000

For details of the connection, refer to the following table.

DFP-D3000 AUX Input 1/2 (DB25, F/Cable M)	DTS-6 Adaptor to JM21 "TS6 to CP500"	DTS-6D Analog out (DB25 M/Cable F)
1 Left Ground	N.C.	N.C.
2 Left Hot	14 Left	14 Left
3 Left Center Cold	N.A.	N.A.
4 Center Ground	N.C.	N.C.
5 Center Hot	20 Center	20 Center
6 Right Center Cold	N.A.	N.A.
7 Right Ground	N.C.	N.C.
8 Right Hot	17 Right	17 Right
9 Left Surround Ground	N.C.	N.C.
10 Left Surround Cold	4 Audio Return	4 Audio Return
11 Right Surround Cold	3 Audio Return	3 Audio Return
12 Sub Woofer Cold	12 Audio Return	12 Audio Return
13 Sub Woofer Ground	N.C.	N.C.
14 Left Cold	1 Audio Return	1 Audio Return
15 Left Center Ground	N.A.	N.A.
16 Left Center Hot	N.A.	N.A.
17 Center Cold	8 Audio Return	8 Audio Return
18 Right Center Ground	N.A.	N.A.
19 Right Center Hot	N.A.	N.A.
20 Right Cold	5 Audio Return	5 Audio Return
21 N.C.	N.C.	N.C.
22 Right Surround Ground	N.C.	N.C.
23 Left Surround Hot	15 Left Surround Out	15 Left Surround Out
24 Right Surround Hot	2 Right Surround Out	2 Right Surround Out
25 Sub Woofer Hot	24 Sub Woofer Out	24 Sub Woofer Out

N.A.: No corresponding function. N.C.: Not connected.

Notes

1. All audio grounds must be connected to the shield side of each twisted pair cables at the DFP-D3000.
2. The DTS-6 audio outputs must be connected using the "DTS6 to CP500 adaptor" provided by the DTS dealer.

9.8 Corresponding to DFP-D3000 Surround EX

9.8.1 Restrictions on Control of Surround EX Decoder

1. For Surround EX, information for expressing “Surround EX” on film in any digital format is not written. For this reason, when controlling the Surround EX processor, there is a need to control the Surround EX decoder from the DFP-D3000 only when processing the Surround EX decoding for the SDDS signal.
2. When performing Surround EX decoding for other digital formats, accurate control from the DFP-D3000 is not possible. In this case, use the control signal from each equipment. Due to effects of the fallback operation on the DFP-D3000, operations may not be smooth in some cases.
3. The DFP-D3000 software must be changed to a version above V2.61. If B-chain settings have already been completed, change the setup software version for the DFP-D3000 to V2.00 build 2.044 or above, and read out the set data before upgrading the version. After upgrading the version, re-send the read out data to the unit.
For DFP-D3000 models shipped after September 1999, use the software provided at shipment.

9.8.2 Connections of Audio System

Connect the audio system as follows.

Of the DFP-D3000 audio outputs, connect the Surround Left output and Surround Right output to the SA-10 Surround input. To connect the Surround outputs of the SA-10, connect the four outputs from the SA-10 (Surround Left, Surround Back-Left, Surround Back-Right, Surround Right) to the speaker via the power amplifier according to the SA-10 manual. In this case, use the switching circuit in the SA-10 to turn ON and OFF the Surround EX mode to switch the sounds.

The following restrictions apply in the combination with the V2.61 software.

- At the DFP-D3000 side, as the EQ setting cannot be changed for every preset, if combining with the Surround EX processor, adjust the level and equalizer of the surround channel at the Surround EX processor side.
(In other words, for the surround channels, adjust the B-chain using the Surround EX processor.)
Therefore at the DFP-D3000, turn OFF the equalizer of the surround channel, and at the same time, adjust the offset of the surround channel level so that the output level of the surround channel becomes -16 dBu. When adjusting the sound level, set the amplitude to a high level at the power amplifier.
- For channels other than the surround channel, adjust the equalizer at the DFP-D3000 side.

Example of Audio System Connection

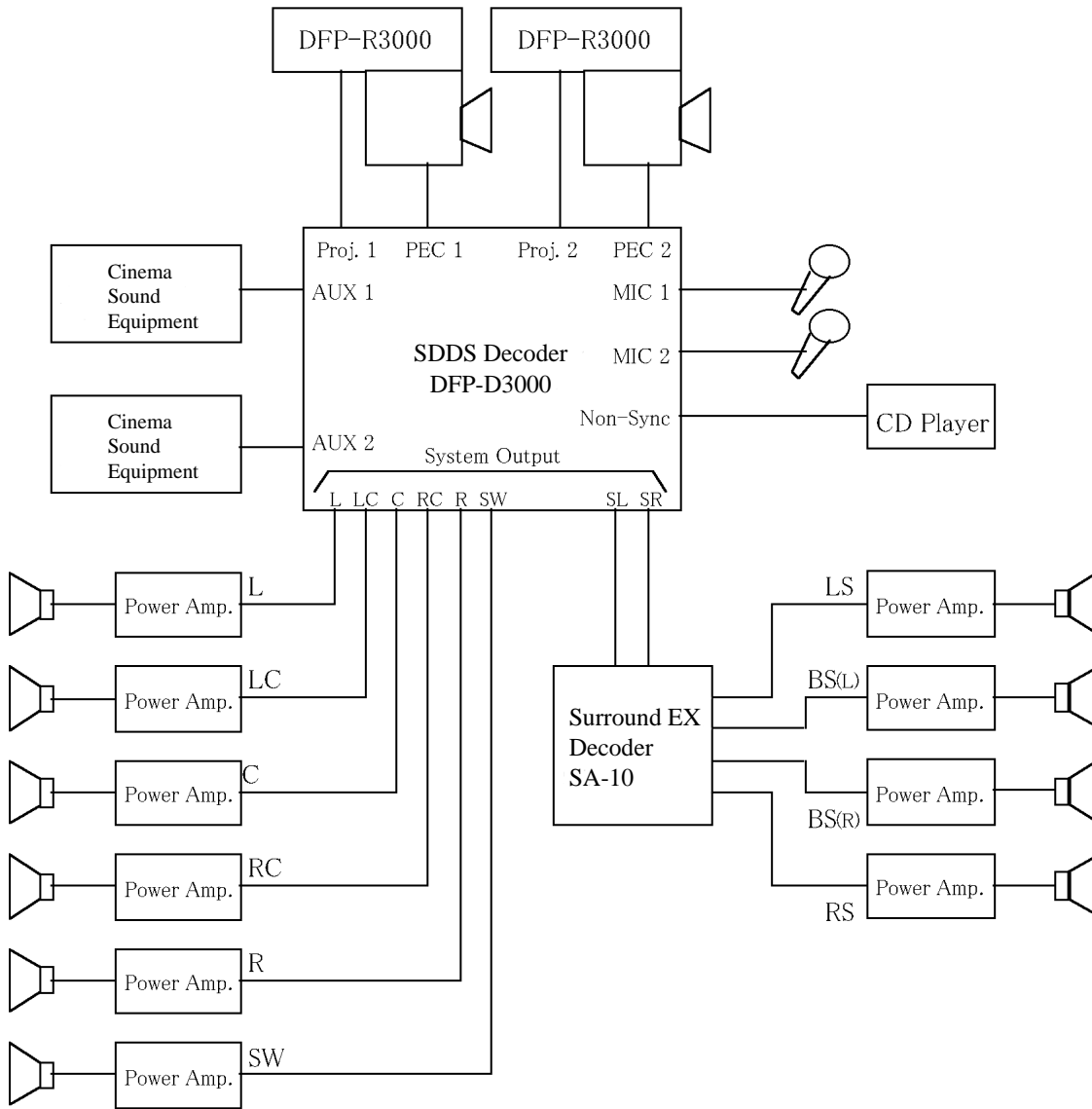

L : Left Channel	LC : Left Center Channel	C : Center Channel
RC : Right Center Channel	R : Right Channel	SW : Sub Woofer Channel
LS : Left Surround Channel	RS : Right Surround Channel	BS : Back Surround Channel

During normal operations: The same sounds are output from the LS channel speaker and BS (L) channel speaker. The same sounds will also be output from the RS channel speaker and BS (R) channel speaker.

During Surround EX: The same sounds are output from the BS (L) channel speaker and BS (R) channel speaker. Different sounds will also be output from the LS channel speaker and RS channel speaker. (In other words, there are three surround channels: LS, BS, and RS.)

9.8.3 Actual Connection of Control System

When controlling operations of the Dolby Laboratories SA-10 (Surround EX processor) from the DFP-D3000 (switch the Surround EX mode between ON and OFF), connect the control input connector on the rear panel of the SA-10 and Automation connector on the DFP-D3000 as follows.

1. Settings at the SA-10 (Surround EX Processor) side

- Set the control mode switch SW1 (located on the daughter board) in the SA-10 to the “CP65” position.
- Push in (Normal position) the “Alignment Switch S602” on the rear of the SA-10 front panel.
- Set the “Surround switch” on the SA-10 front panel to the “Enable” position.

2. Connections of the Control Cable Between the DFP-D3000 and SA-10

- Connect Pin 14 (Logic Common) of the DFP-D3000 Automation connector to Pin 12 (GND) of the Control Input connector of SA-10.
- Connect Pin 32 (SDDS OK) of the DFP-D3000 Automation connector to Pin 4 (CTRL 4, EX decode mode) of the Control Input connector of SA-10.
- Connect Pin 36 (ACM) of the DFP-D3000 Automation connector to Pin 2 (CTRL1, non decode mode) of the Control Input connector of SA-10.

With this connection, the signal for indicating the read state of the SDDS is sent to the SA-10 control signal input which is the Surround EX Processor, and the SA-10 operations are controlled via the control cable according to the SDDS signal state.

9.8.4 SA-10 Operations When Controlling from the DFP-D3000

The system combining the DFP-D3000 and SA-10 performs the following operations at the settings and connections described until now.

1. When the SDDS film is played back

The following operations are performed when the SDDS film is played back.

When the SDDS film is identified by the DFP-D3000, the SDDS OK pulse is output from Pin 32 of the Automation connector. As a result of sending the pulse to the SA-10 control input, the “Surround EX Mode” LED lights up on the Surround EX Processor SA-10, and the Surround EX decode function turns ON (EX mode).

If there are large scratches on the SDDS film, or if film with no SDDS signal arrives and SDDS signal cannot be read, the ACM pulse is output from the Pin 36 of the Automation connector. As a result, the “Surround EX Mode” LED lights up on the Surround EX Processor SA-10, and the Surround EX decode function goes OFF (normal mode).

2. When other format film is played back

In this case, even if the Surround Mode switch on the SA-10 front panel is set to the “Surround EX Enable” mode, the “Surround EX Mode” LED lights up on the Surround EX Processor SA-10, and the Surround EX decode function goes OFF (normal mode).

Note

Even other format sounds (Dolby Digital, DTS, Dolby SR) are played without selecting the SDDS sound in the use of films recorded with SDDS, Surround EX control will be performed using the read state of the SDDS data. This must be borne in mind carefully.

9.8.5 Controlling Surround EX from DA-20

When combining the Dolby Digital format decoder Dolby Laboratories DA-20 and DFP-D3000, the SDDS decoder DFP-D3000 should be used instead of the CP-65 and CP-55 Dolby Laboratories Cinema sound processors. For the DFP-D3000, as Dolby Digital format conditions are detected using the level signal (method of determining the OK/NG state of the digital format according to the High/Low state of the terminal voltage) as done in the Dolby Laboratories cinema sound processor CP-200, operations will be different from the current Dolby Laboratories cinema processor (adopts pulse signal input).

To control surround EX from the DA-20, use the following method.

1. Since the DFP-D3000 is designed so that the designated operations are performed when it receives the Dolby Laboratories CP-200 control signal (voltage level output method), set the DA-20 operations in the same way as when CP-200 is used. For reference, a diagram showing the connection of the DFP-D3000 and DA-20 is shown on the next page.
2. Distribute the signal sent from the DA-20 from the DFP-D3000 Automation connector, convert the signal to a pulse signal, and send to the SA-10 control signal input. In this case, use the signal conversion adapter Cat. 845 available from Dolby. Connect this adapter to the SA-10 Control Input terminal (J3). Specifically, connect DA-20 and DFP-D3000.

DA-20, Sense/Control (J6, 25-pin D-sub)	DFP-D3000 Automation (37-pin D-sub)	Cat. 845 (to SA-10, J3 Control Input)
Pin 1, CTRL0 Output	Pin 34: AUX1 digital data OK or Pin 35: Aux2 digital data OK	Red Wire (for Pin 1)

Note that with the Cat. 845 adapter, true level signals are not converted to pulse signals (level signal components are continuously output). As a consequence, SA-10 cannot be controlled simultaneously from all digital formats. To control SA-10 from other formats, stop the Cat. 845 operations. For details on the Cat. 845, contact Dolby Laboratories or a Dolby Laboratories Dealer.

At such settings, when Dolby Digital format signals are read correctly, the Surround EX decoder will operate and Surround EX decoding is performed. If the Dolby Digital format signals are not read correctly, Surround EX decoding will not be performed. In this case, when preset is selected but the Preset corresponding to the Dolby Digital format signal is not selected correctly, Surround EX decoding may be performed where not needed.

To control SA-10 from the DFP-D3000, third party solutions are available from a variety of outside vendors and suppliers of cinema equipment, such as Smart Devices Inc (USA), Hasso GmbH (Germany) and others. Contact the vendors directly for the latest information about their available products.

1. Connecting DA-20 to the AUX1 input terminal

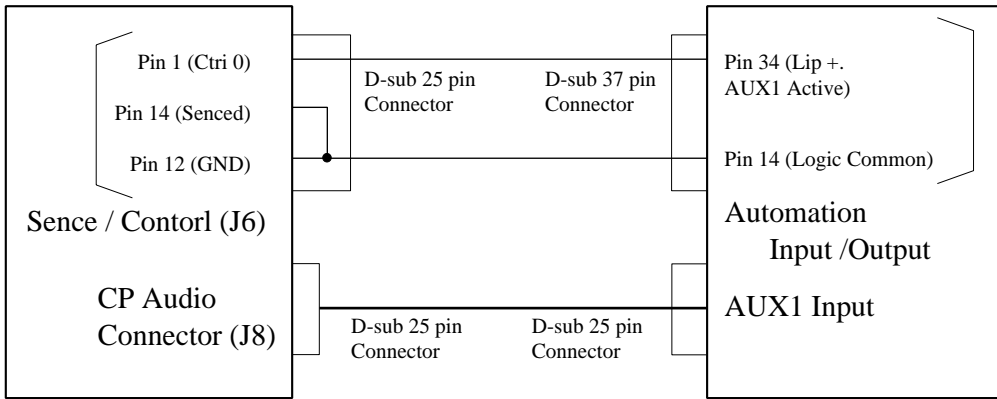

Dolby Laboratories, Inc. DA-20

DFP-D3000

2. Connecting DA-20 to the AUX2 input terminal

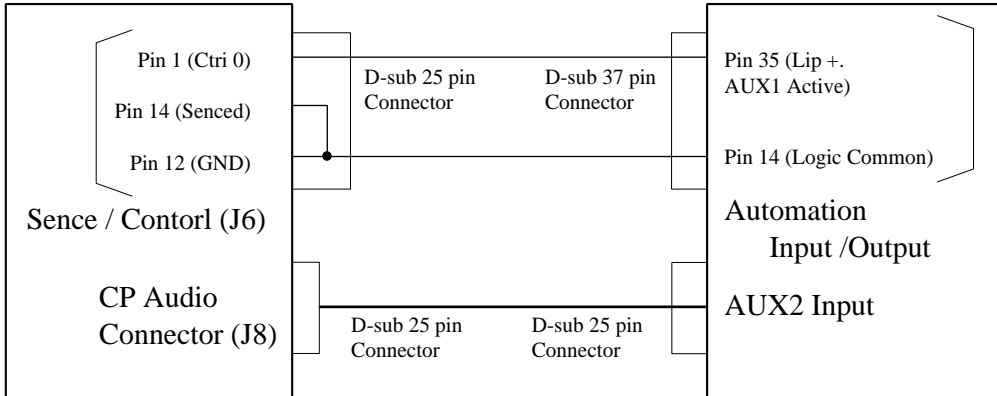

Dolby Laboratories, Inc. DA-20

DFP-D3000

9.8.6 Controlling Surround EX from DTS-6 or DTS-6D

When using the DTS Co. DTS-6 or DTS-6D in the DFP-D3000 system, SA-10 operations can be controlled from these cinema processors (DTS decoder) in the DFP-D3000 system.

In this case, connect the control cables of the DTS-6 or DTS-6D and SA-10 as follows. In this case, the SA-10 can be controlled regardless of the DFP-D3000 control cables.

DTS-6 “to BS22” connector (IDC 10-pin Connector)	DTS-6D Automation connector (DB25 female)	SA-10 J3, Control Input (DB25 female)
Pin 6: Relay Common	Pin 13: Output common	Pin 12: GND
Pin 9: out (N.O.)	Pin 11: Logic SR	Pin 2: CTRL 1, non-decode Mode
Pin 7: IN (N.O)	Pin 25: Logic DTS	Pin 5: CTRL 4, EX decode mode

The following cables are required other than the above for the DTS-6D system.

Connect Pin 6 “Force SR +” and Pin 9 “+5V Output” of the Automation connector.

Connect Pin 19 “Force SR –” and Pin 22 “5V GND” of the Automation connector.

9.8.7 Controlling Surround EX control from Automation Controller

When fallback using several digital formats is adopted in the DFP-D3000 system, or the SDDS signal cannot be read, it is necessary to cancel the SA-10 Surround EX decoding operations as soon as possible. It is also necessary to ensure compatibility for films not recorded with the Surround EX signal. By changing the preset settings of the DFP-D3000, and preparing preset using the Surround EX not corresponding to the SDDS input and preset not using the Surround EX (same as the Dolby Laboratories CP-500), Surround EX can be controlled from an external Automation controller. The examples of preset settings and connection methods of control cables are shown on the next page onwards. However when using this connection method, set the Processor Select switch in the SA-10 to the CP-500 side.

DFP-D3000 Preset	DFP-D3000 Automation (37 pin, D-Sub, Female)	SA-10, J3 Control Input (25 pin, D-sub, Female)
Preset 1: SDDS	Pin 4: Preset 1	Pin 2: CTRL 1
Preset 2: Non-Sync	Pin 5: Preset 2	Pin 3: CTRL 2
Preset 3: Mono	(Pin 6: Ptdry 3) No need	No need to connect
Preset 4: NR1	Pin 7: Preset 4	Pin 4: CTRL 3
Preset 5: NR2	Pin 8: Preset 5	Pin 5: CTRL 4
Preset 6: AUX 1	Pin 9: Preset 6	Pin 6: CTRL 5
Preset 7: AUX 2	Pin 10: Preset 7	Pin 7: CTRL 6
Preset 8: SDDS EX	Pin 11: Preset 8	Pin 8: CTRL 7
	Pin 16: Tally Common	Pin 12: GND

9.8.8 Adjustments of Audio System

Details of the connections and adjustments of the audio system are provided in “Connections of the Audio System”. Below, the adjustment methods are described.

Of the DFP-D3000 audio output, the Surround Left output and Surround Right output will be connected to the Surround input of the SA-10. Currently, as the EQ setting cannot be changed for each preset in the DFP-D3000, when combining it with the Surround EX processor, adjust the level with the equalizer of the surround channel at the Surround EX processor side. In other words, perform B-chain adjustments using the Surround EX processor for the surround channels.

For the Surround EX processor, if the level of signals input to the surround processor is not adjusted properly, the designated surround effects cannot be obtained. For this reason, there is a need to adjust the level of signals sent to the Surround EX processor from the SDDS.

The following describes the procedures for setting the level of the signal output from the DFP-D3000 to the Surround EX processor, and the equalizer.

Equipment required

- Personal computer installing the DFP-D3000 setup software
- Interlink cables (cross cables and all pins must be cross connected)
- Audio level meter (or AC voltmeter)

Adjusting/setting procedures and measurements

1. Connect the DFP-D3000 and personal computer using interlink cables. When using a commercially available interlink cable, as male D-Sub 9 pin connectors are provided at the two ends of the cable, it is necessary to change only the DFP-D3000 side to the female connector. In this case, use a commercially available polarity converter connector (gender changer) to convert the connector shape. As the DFP-D3000 uses mm screws (ISO standard) for fixing the connector (side secured by the screws), when using cables for the PC, the adjustment/setting/measurement can be done more easier if the fixing screws at the connecting side of the cable to the PC is removed.
2. Turn on the power of the DFP-D3000 and Surround EX processor. Turn the power of the power amplifier until level adjustments complete.

- Start the DFP-D3000 setup software on the PC. When started, the screen shown in Fig. 1 will be displayed. Click “Connect to DFP” from the Config menu to start communication with the DFP-D3000. At this time, the serial number information of the unit will be required. The serial number of the unit is indicated at the name plate on the right side of the unit. If the setup software has not yet been started, the serial number can also be viewed on the LCD screen of the DFP-D3000. (For details on operations, refer to the menu tree in the operation manual.)

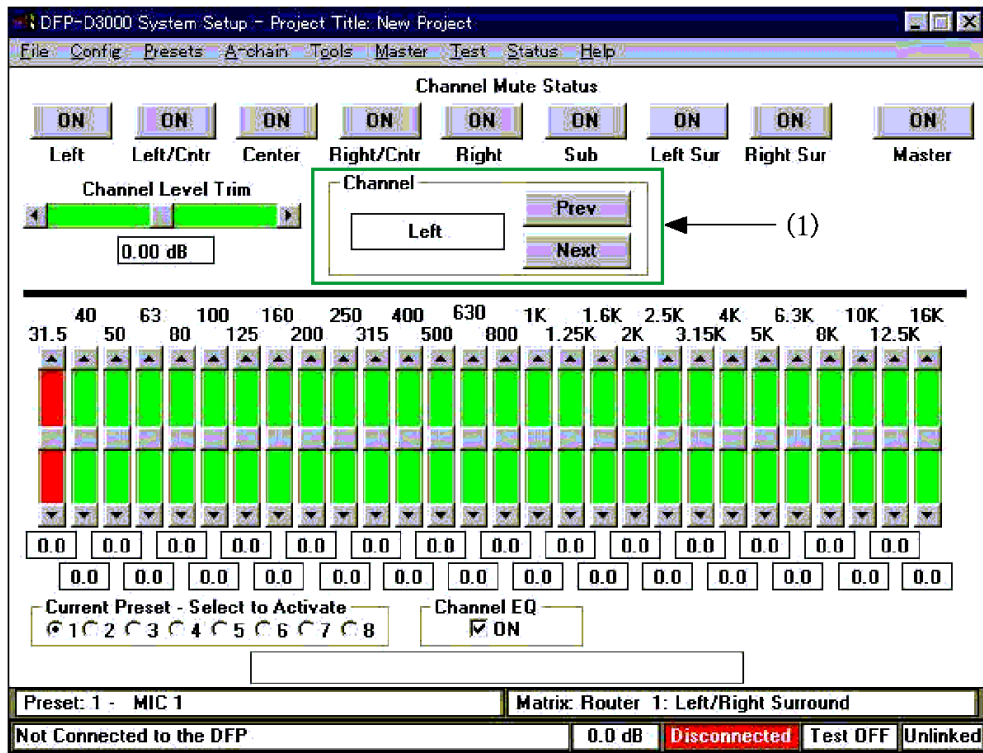

Fig. 1. Initial State of Setup Screen

- Select “Master DFP-D3000” from the “Master” menu at the screen shown in Fig. 1. The screen shown in Fig. 2 will be displayed.

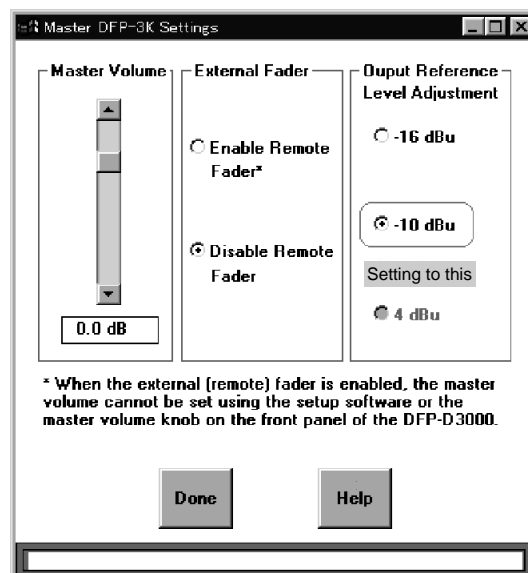

Fig.2. DFP-D3000 Output Reference Level Setting Screen

5. Check that the Master Output level is -10 dBu on the screen shown in Fig. 2.
(Setting at shipment)
If the setting is different, change the setting. After setting, press the Done button to exit this screen.
(Returns to the screen in Fig .1.)
6. Select “Signal Generation” from the “Test” menu at the screen shown in Fig. 1. The screen shown in Fig. 3 will be displayed.

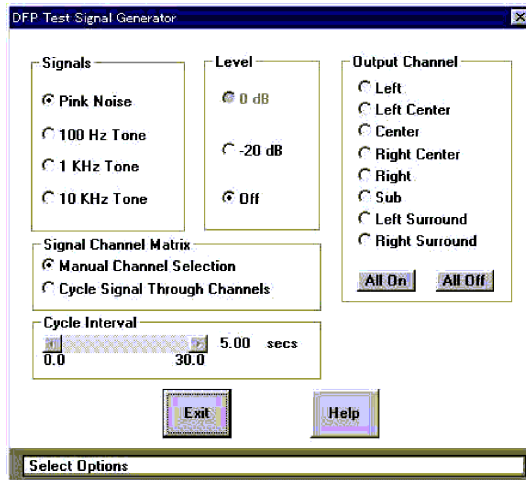

Fig. 3. Setting Screen of DFP-D3000 Oscillator

7. Change the oscillator settings as follows at this screen. (Refer to Fig. 4.)
 Signals: Select “1 kHz Tone”.
 Level: Select “ -20 dB”.
 Output channel: Press “All On” and select all outputs.

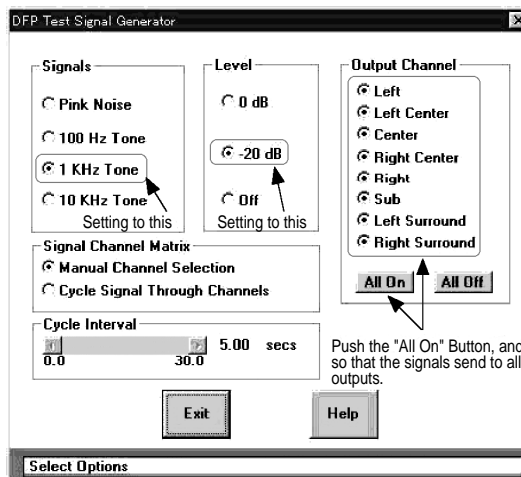

Fig. 4. DFP-D3000 Oscillator Setting in Surround EX Processor Level Adjustments

The message shown in Fig. 5 appears. Press the “Yes” button.

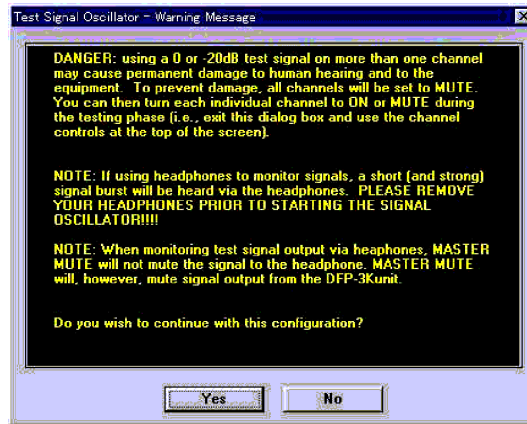

Fig. 5. Warning Message When the Oscillator is set to ON

8. After setting the oscillator, select “EXIT” at the screen shown in Fig. 4 to exit the oscillator screen. At this time, the audio output and master output of each channel on the channel adjustment screen will be muted. As shown in Fig. 6, press the Surround channel and master output buttons, and set the outputs to “ON”.

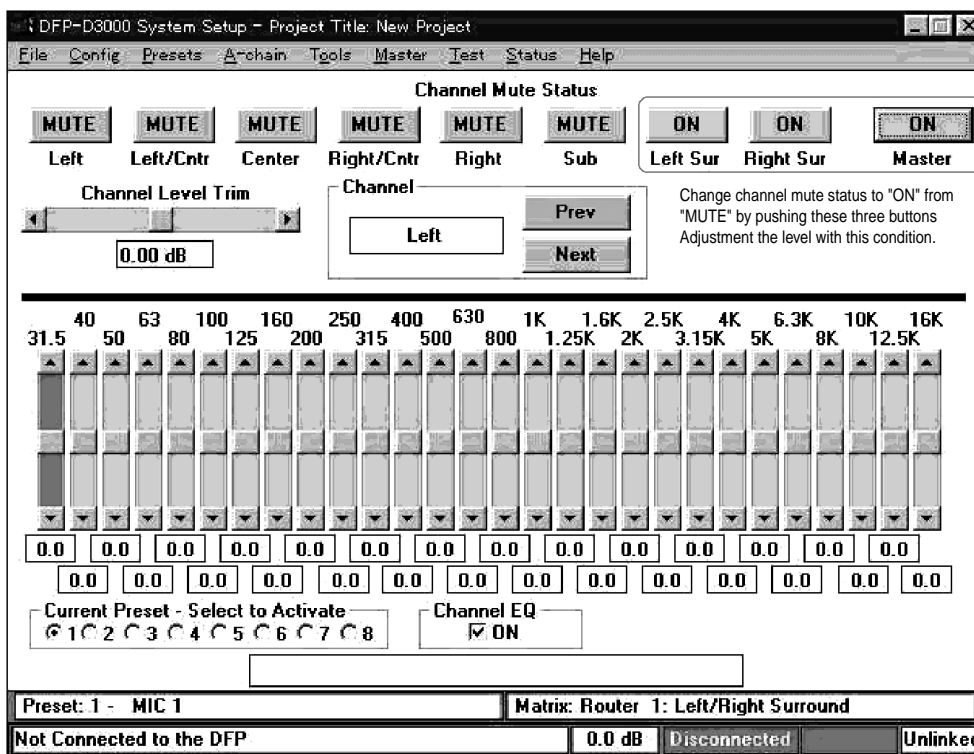

Fig. 6. Channel Screen Settings After Oscillator is Turned ON

9. Using the “Prev” and “Next” buttons at (1) on the screen shown in Fig. 1, select the “Surround Left” and “Surround Right” as the channels to be set. (Set the display in the white frame to “Surround Left” and “Surround Right”). The screen changes to that shown in Fig. 7.

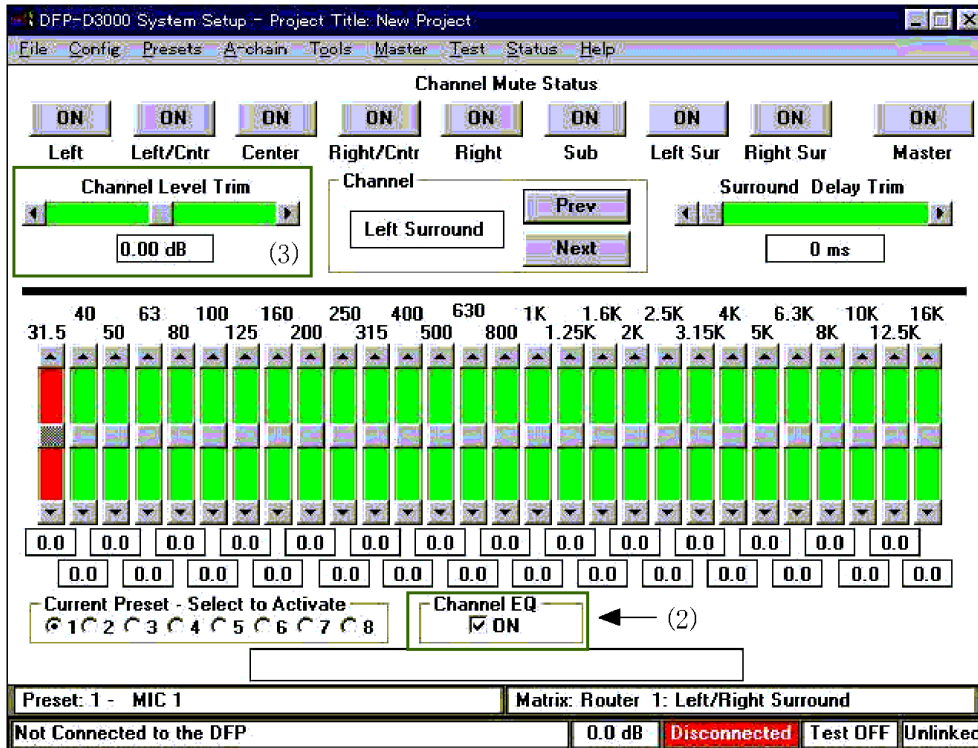

Fig. 7. Screen for Adjustments (For Surround Left)

10. If the check box on the left of “ON” displayed at “Channel EQ” at (2) of the screen shown in Fig. 7 is checked, remove the check mark (as shown in Fig. 9).
11. Move the slider of “Channel Level Trim” at (3) at the screen shown in the Fig. 7, and lower the audio output level from -3 dB to -6 dB. (At the initial state, the audio output reference level will be -10 dBu (approximately 240 mV for the voltage display, state shown in Fig. 8).
12. In this state, measure the level of the DFP-D300 Surround Left channel output and Surround Right channel output. Adjust the “Channel Level Trim” value of the surround channel measured so that the output level becomes 120 mV (-16 dBu). (Refer to the Surround EX processor manual for the test points measured.) Fig. 8 shows an example of the settings at the screen when adjustments have been completed.

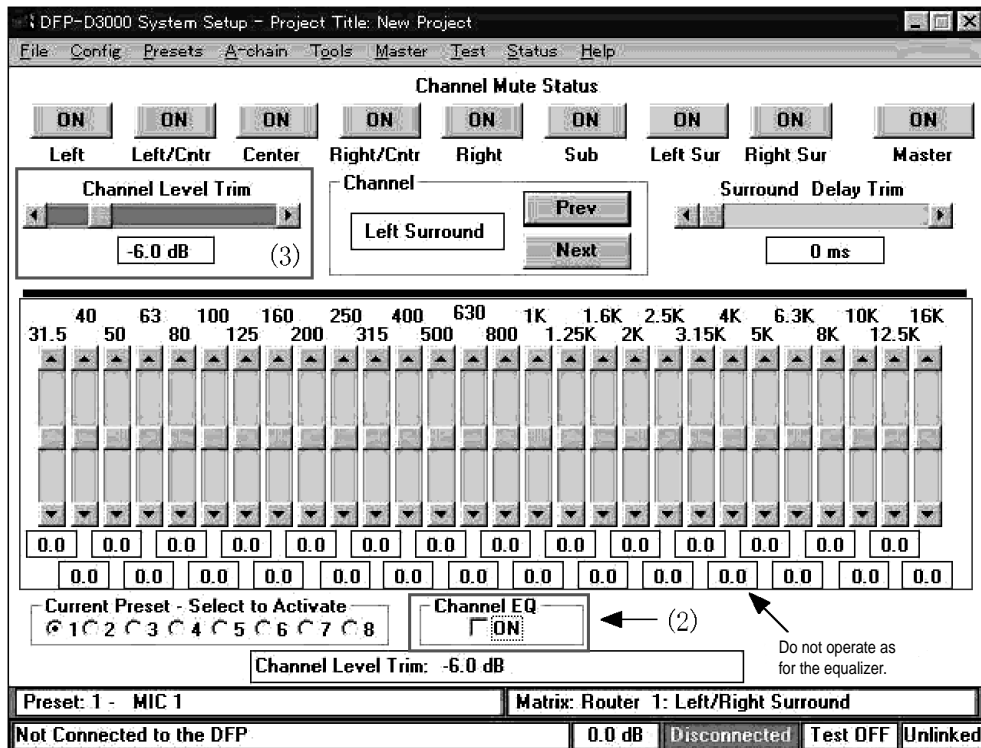

Fig. 8. Example of Screen After Completing Checks and Adjustments

13. After adjusting the level of one surround channel, return to step 9, and adjust the level of the other surround channel.
14. After adjusting the level of the surround channel, save the changed data on a disk. Refer to steps 6,7,8 and stop the operations of the oscillator. (Operations can be stopped once here. In this case, end the setup software.)
15. Click “Master” at “Channel Mute Status” of the setup software to mute the master volume, and then turn on the power of the power amplifier.
16. Click “Master” of the “Channel Mute Status” to unmute the master volume, and then adjust the B-chain (surround adjustment: adjustment of frequency characteristics and level) according to the Surround EX processor manual at the Surround EX processor side (and amplifier level adjustment knob). If pink noise must be generated at the Cinema Processor side, generate pink noises from the DFP-D3000 setup software.
17. Perform all adjustments of the B-chain other than the Surround output as done normally at the DFP-D3000 side.
18. After completing all adjustments, click “Disconnect to DFP” from the Config menu on the setup software, end communication with the DFP-D3000 to end the setup software.

Note

It is also possible to play film recorded with Dolby tone instead of the built-in oscillator to adjust the output level of the DFP-D3000. If SDDS format film with such tones are not available, use a Dolby Digital format or analog film and switch the preset according to the film used.

In this case, open the "Preset Configuration" in the "Preset" menu, set the "Offset Trim" setting of the preset number corresponding to the format of the film played back to 0 dB before performing the actual adjustments.

When performing adjustments, also switch the preset setting according to the corresponding film format at "Current Preset-Select to Activate" at the bottom left of the channel adjustment screen.

As of December 1999, there is no film for adjustment recorded with Dolby tones in the SDDS format. Therefore use the Dolby Digital format or analog format level film or use the built-in oscillator of the DFP-D3000.

One of the reasons for why this manual recommends the use of the built-in oscillator is because; effects of the offset trim setting at each preset may be received during adjustments when the Surround EX processor is added to the existing equipment.

(When the offset trim is set, there may be a difference between the reference level (-20 dB) in the unit and the level of the signal from the film used for adjusting the signal level). When the built-in oscillator is used, the effects of the offset trim setting are not received.

9.9 Test Cable for Performing A-Chain Adjustment

The DFP-D3000 provides a convenient, front-panel phone jack with a selector switch. This jack can be used to connect a spectrum analyzer (RTA) and X-Y oscilloscope to facilitate A-Chain calibrations and adjustments. The following diagram shows the connections of the cables for connecting the spectrum analyzer and X-Y oscilloscope to the DFP-3000 headphone.

Required parts

1/4-inch (6.3 mm) stereo headphone (TRS or Tip, Ring, Sleeve) plug
Shielded cable

Actual Wiring Diagram

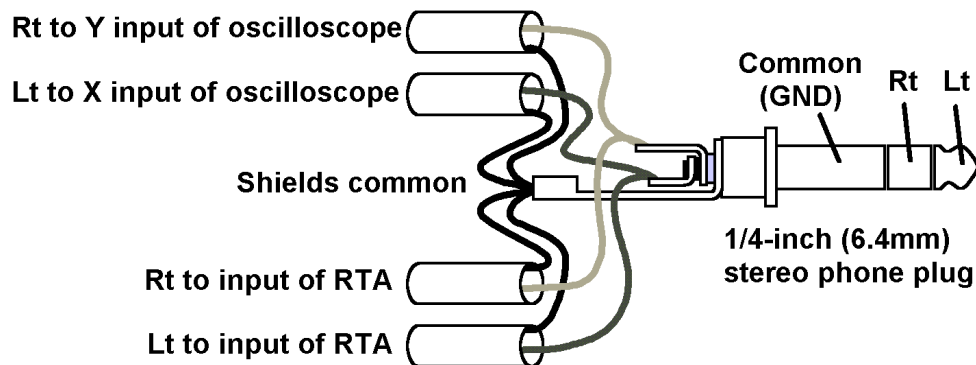

Notes

1. In the above Actual Wiring Diagram, the headphone plug cover is shown removed.
2. Use quality shielded cables for connecting the external equipment and the headphone plug. Always connect all shielded cables (shaded part) to the Sleeve Common terminal of the headphone plug.
3. The input terminal of the external equipment side differs in shape at each equipment. To construct a cable, be sure to refer to the manual of each equipment. Also be sure to connect the shielded cables to the common (GND) terminal of the input signal.
4. When checking and adjusting the A-chain using this cable, set the DFP-D3000 headphone monitor select switch to No. 5 (Lt + Rt) before starting work. This information will also be displayed on the LCD during the setting.

9.10 Adjusting the Analog Track Pickup

Digital audio tracks set a very high standard of quality for theatrical sound playback. In order to minimize the difference between sound from digital tracks and sound reproduced from a film's optical tracks, the proper skills as well as caution are required for ensuring the best performance of the optical reader. This chapter mainly describes the forward scan reader. As reverse scan readers have related adjustments which may be slightly different for each brand, contact the appropriate manufacturer for specific instructions. When adjusting the optical reader, follow the adjustment method indicated in the manual of the reader used.

When adjusting A-Chain inputs, it is not necessary to provide commands to the Automation system of the projector if the exciter lamp of the analog surround track is lit. (Only when the exciter lamp is off must the Automation system be operated to light the exciter lamp.) The exciter lamp voltage should normally be set to 75-85 % of its rated voltage as recommended by the manufacturer. As the following adjustments typically interact with each other, they must be rechecked after initial settings.

9.10.1 Preliminary Preparations Before Adjustments

First thoroughly clean the sound head optics. Replace the exciter lamp if it is discolored or if it is not sufficiently bright across the width of the slit and when its light falls on a white card held about an inch in front of the optics. Be sure that the solar cell is mounted 1 mm away from the film. The most common causes of uneven illumination are misaligned optics, dirty or aged exciter lamp, dirty optics or slit, and running of the exciter lamp at a voltage that is too low.

9.10.2 Lateral Film Guide Adjustment

The next step in adjusting the projector's optical reader is to ensure that the optical pickup is correctly adjusted to the optical tracks on the film. This is done by playing a loop of the SMPTE Buzz Track test film and adjusting the projector's lateral film guide for equal and minimum high and low frequency sound from the left and right outputs. If you are adjusting an overscanning reverse scan reader you can also perform this adjustment using the X-Y oscilloscope by equalizing the perpendicular X and Y traces.

9.10.3 Lateral Exciter Lamp Adjustment

Next in setting up a forward scan reader, roll a Cat. 97 "left/right" or "crosstalk" loop and observe the signal when the film is run using a dual trace oscilloscope. Adjust the lateral position of the exciter lamp to equalize the left and right output signal levels. Generally this adjustment can be facilitated by setting so that the two channels overlap on the oscilloscope.

9.10.4 Lateral Solar Cell Adjustment

While playing the left/right loop, adjust the lateral position of the solar cell so as to achieve minimal crosstalk between left and right output outputs. Generally, this adjustment can be facilitated by setting so that two input states can be observed separately on the oscilloscope.

9.10.5 Vertical Adjustment of Exciter Lamp

For forward scan readers, set the oscilloscope to the X-Y display mode, and connect the same signals to the RTA (real time analyzer, spectrum analyzer). Play a loop film recorded with (black-and-white) pink noise signal, and adjust the output level from the analog pickup to the point where the highest frequency characteristics become. If necessary, adjust to the preferred frequency characteristics.

9.10.6 Slit Lens Adjustment

Adjust the focus of the slit lens of the pickup where the frequency characteristics of the pink noise becomes the flattest. Rotate the slit lens so that the phase difference becomes minimum on the X-Y oscilloscope, and adjust the azimuth of the slit.

9.10.7 Double Checking of Illumination Inconsistency

Even illumination from the slits is essential to reducing high level distortion and in the decoding of surround signals from the Lt/Rt. Falloff at the outside edges will result in high frequency loss and playback that sounds muffled. Assuring proper playback of high levels is especially important, as modern analog track cameras can readily print stereo tracks at 130 % modulation without loss of the septum, and this extra range is commonly utilized.

To check for proper illumination, play a 100 % modulation alignment film, such as the Cat. 97 left/right film, and also a 50 % or 60 % modulation alignment film, such as the Cat. 69T. The levels of the left signal and right signal should be equal to each other when playing either film. If they are not, the slit image is imperfect in illumination flatness or in its alignment on the solar cell. The result will be distortion of loud sounds and leakage into the surround speakers.

This same test can be done using the old evenness of illumination test film, also called the "snake loop" or in Europe "scanning beam," (SMPTE Test Film No. P35-SB) though this film was designed for mono solar cells. The most direct means of testing for evenness of illumination may be the Cat. 566 Illumination Uniformity test film. This film does not have conventional stereo tracks; instead it has six tracks of 100 Hz to 4 kHz spread across the entire optical track area. The Lt and Rt outputs are to be summed and sent to a spectrum analyzer, where the relative heights of the six bands gives direct indication of illumination of the slit across the entire solar cell.

9.10.8 Wiring Check

As a basic wiring check, slowly block the reader's sound lens and note that the right channel level drops before the left channel.

This completes the mechanical adjustments of the analog track reader, but remember that these adjustments interact and it may be necessary to repeat these procedures to obtain the very best performance.

9.11 Description of the DFP-D3000 Setup Software Menus

The DFP-D3000 is provided with a DFP-D3000 setup software which runs on Windows 95 for simple settings of functions. The use of this software allows easy settings of functions of the DFP-D3000. The data set can be saved and copied on a PC.

The software screens described in this chapter are those of the Version 2.00 Build 2.054. Therefore, screen contents and menu items may differ according to the software version. For details on the latest setup procedure, contact a Sony Service Center.

9.11.1 Start-up Screen

You can perform B-chain adjustments (surround adjustments) of each channel at this screen. When the system is started, the left channel will be started as shown in the following diagram. Only the sub woofer channel screen differs. The sub woofer screen is displayed on the next page.

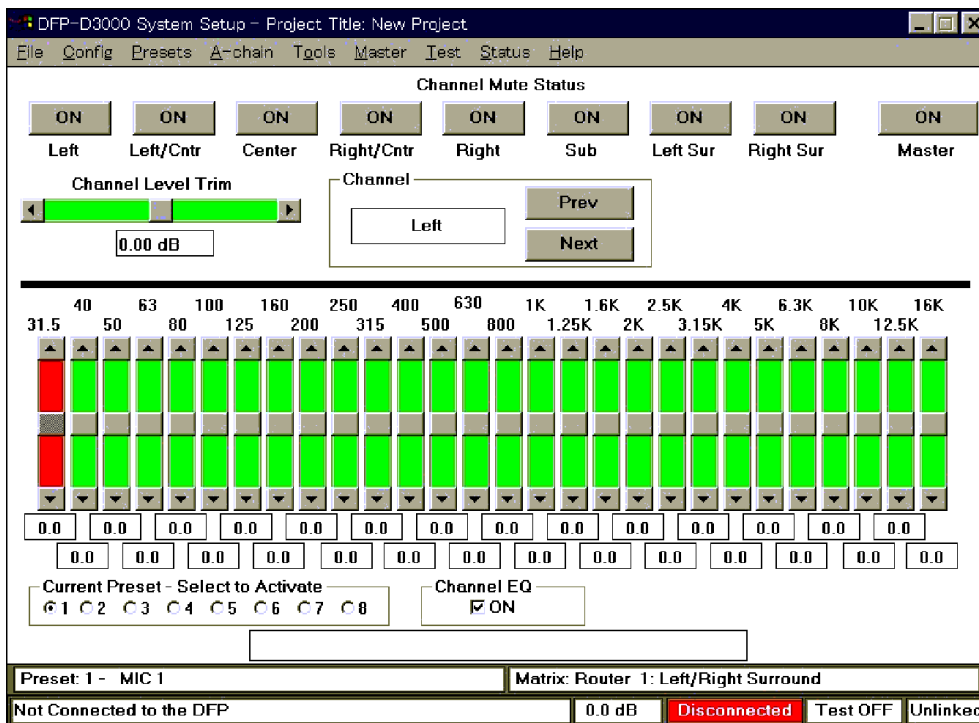

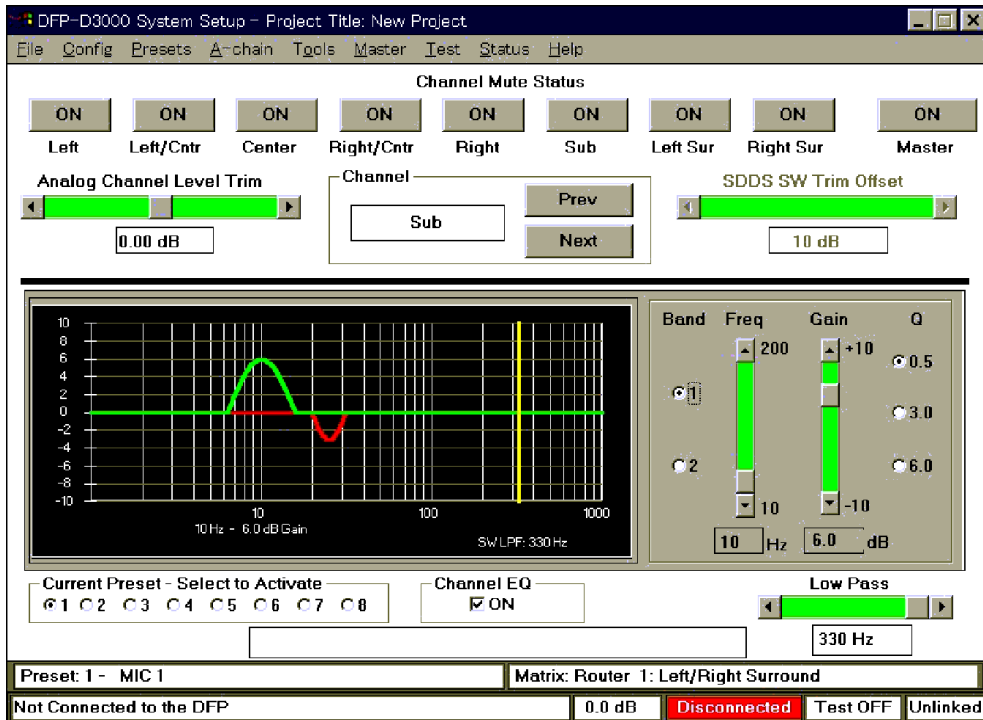

1. Start-up Screen Menus

- File menu: Menu on file operations
- Config menu: DFP-D3000 connection and software setting menus
- Presets menu: DFP-D3000 preset function setting menus
- A-chain menu: DFP-D3000 AUX input, PEC input, MIC input, and Non-Sync input setting menus
- Tools menu: Menu of useful functions for DFP-D3000 settings
- Master menu: DFP-D3000 audio output and Lip Sync setting menus
- Test menu: DFP-D3000 adjustment signal and check function menus
- Status screen: Displays the DFP-D3000 and film status
- Help menu: DFP-D3000 setup software help menu

2. Details of settings at the Start-up screen

The following can be set at the start-up screen (B-chain adjustment screen)

- Room equalizer adjustment
Adjustment of room surround characteristics to optimum levels while observing the measuring device (RTA, real time analyzer) used. The parametric equalizer is used for the subwoofer channel, while the graphic equalizer is used for the other channels.
- Level adjustment of each channel
Corrects the differences in level caused by deviation of amplifier characteristics and deviation of speaker characteristics.
The analog input level and SDDS input level can be set separately for the subwoofer channel only.
- Equalizer ON/OFF for each channel
The room equalizer can be turned ON/OFF by channel. This is effective regardless of the preset setting.
- Mute ON/OFF setting by channel
- Mute ON/OFF setting of the master output
- Switching of room equalizer screen

9.11.2 Description of File Menu Items

The following shows the File menu screen.

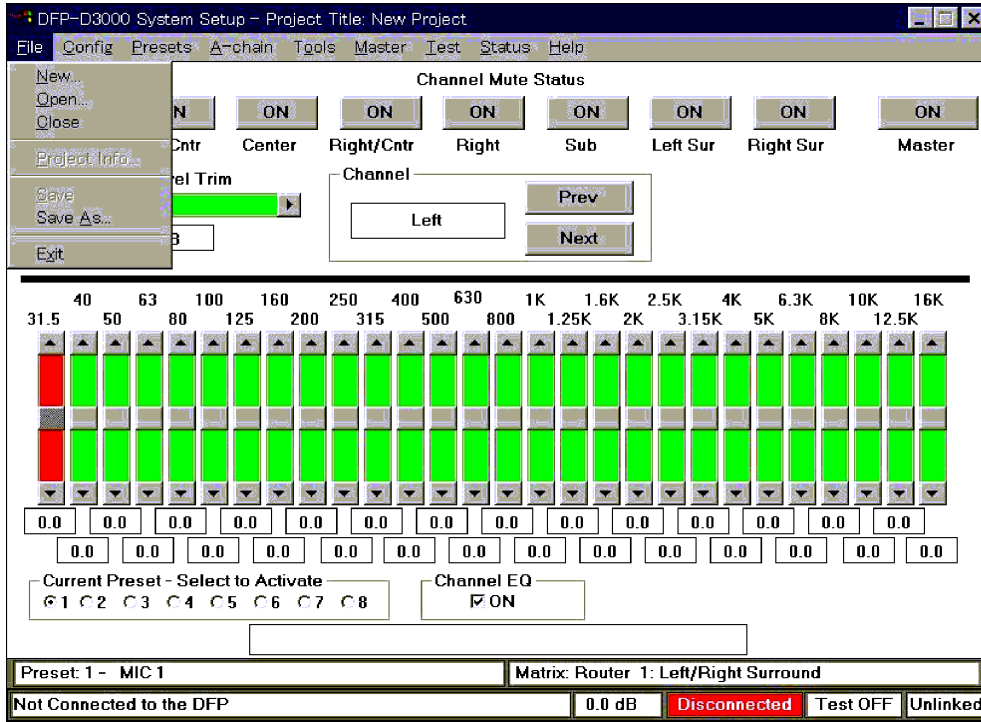

The items of the File menu have the following functions.

- New: Opens a new project file
- Open: Opens the project file on the disk
- Close: Closes the current project file opened
- Project Info: Displays the current project information (screen name, etc.)
- Save: Saves the opened project in a file
- Save as: Saves the current project opened in a new file
- Exit: Ends the setup software

9.11.3 Description of Config Menu Items

The following shows the Config menu screen.

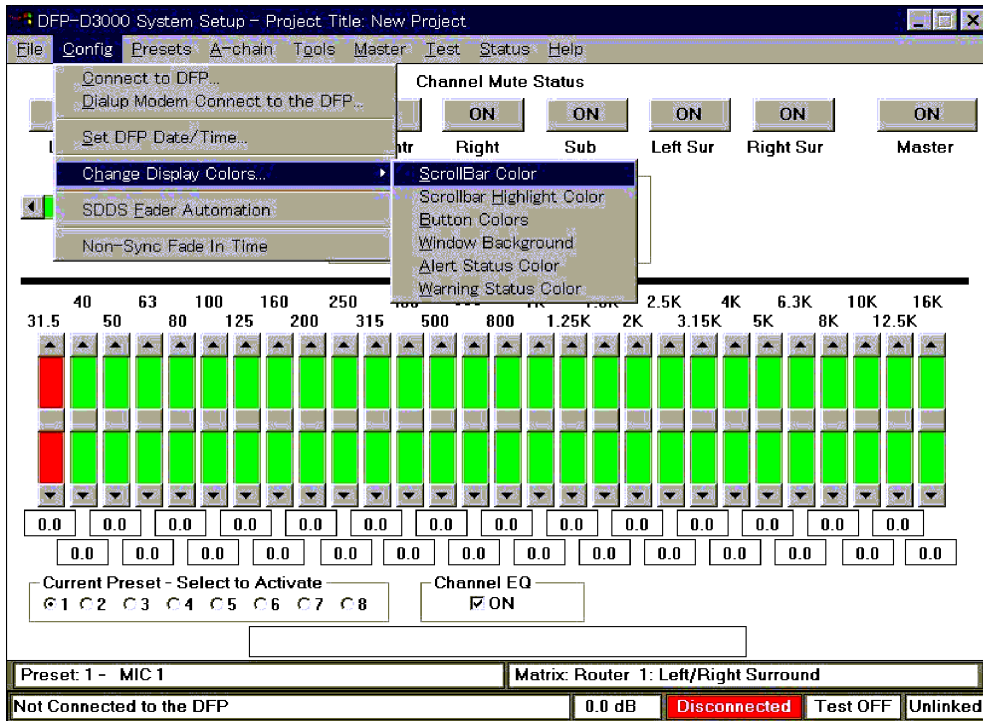

The items of the Config menu have the following functions.

- Connect to DFP: Connects to the DFP-D3000 (displayed when not connected)
- Disconnect to DFP: Disconnects the connection with the DFP-D3000 (displayed when connected)
- Dial up Modem Connect to DFP: Currently not supported (connected through the modem)
- Set DFP Date/Time: Sets the internal clock of the DFP-D3000
- Change Display colors: Sets the color of the setup software screen
 - Scroll Bar: Screen scroll bar color
 - Scroll Bar Highlight Color: Highlighted scroll bar color
 - Button Colors: Screen button color
 - Window Back Ground: Window background color
 - Alert Status Color: Alert display color
 - Warning Status color: Warning display color
- SDDS Fader Automation: SDDS fader Automation setting
- Non-Sync Fade In Time: Used for controlling the fader according to the SDDS title data
- Non-Sync Fade In Time: Fad-in time setting when Non-sync input is selected

9.11.4 Description of Preset Menu Items

The following shows the Preset menu screen.

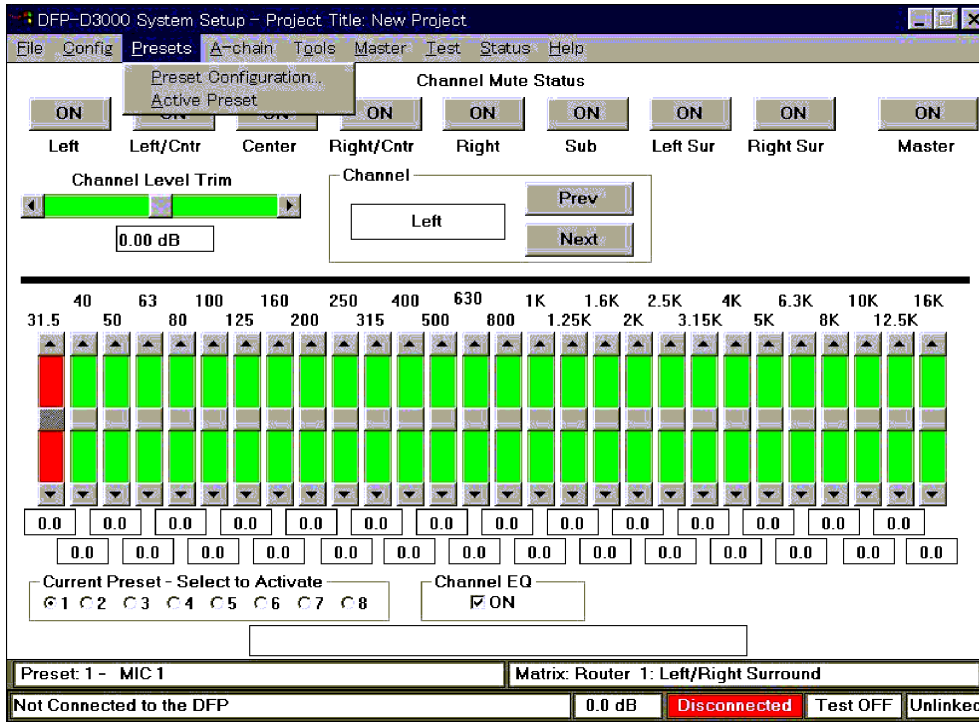

The items of the Preset menu have the following functions.

Preset Configuration: Setting screen of inputs, matrices, and levels corresponding to each preset

Active Preset: Screen for switching presets from the PC

9.11.5 Description of A-Chain Menu Items

The following shows the A-Chain menu screen.

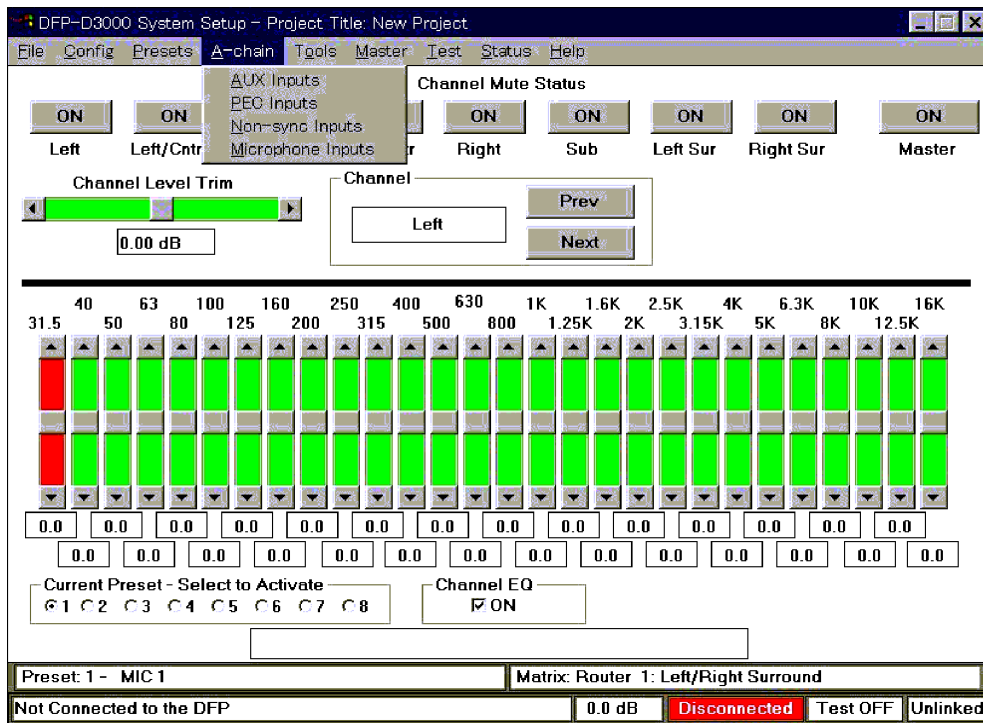

The items of the A-Chain menu have the following functions.

AUX Inputs: Reference input level setting of each AUX input

PEC Inputs: PEC input adjustment menu

The following screen appears when this is selected.

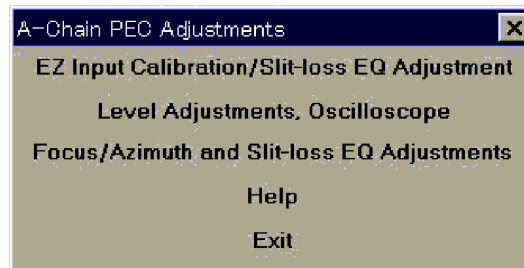

Level Adjustments Oscilloscope:

Displays the PEC signal level adjustment screen and wave

Focus/Azimuth and Slit loss EQ adjustments:

Displays the PEC focus and azimuth adjustment support and slit loss EQ setting screen

Help:

Recalls PEC input adjustment help

Exit:

Ends PEC input adjustments

Non-sync Inputs: For adjusting the Non-sync input level

Microphone Inputs: Mic-Input level adjustment

9.11.6 Description of Tools Menu Items

The following shows the Tool menu screen.

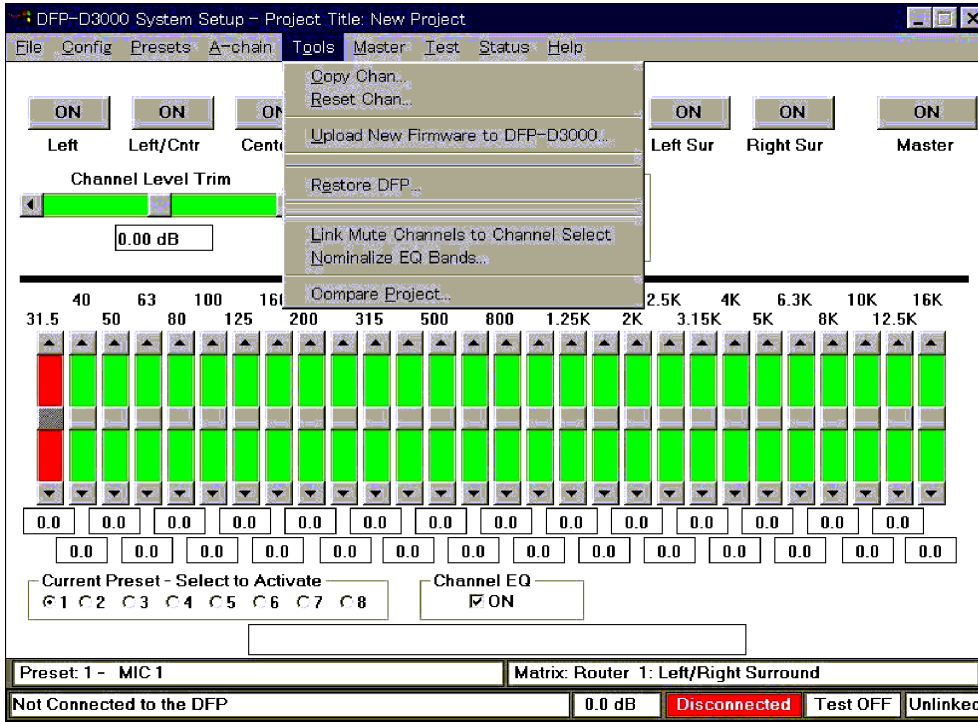

The items of the Tool menu have the following functions.

- Copy Chan: Copies the B-chain setting channel
- Reset Chan: Returns the B-chain adjustment value to the initial state (0)
- Upload New Firmware to DFP-D3000: For installing new software (firmware) to the DFP-D3000.
- Restore DFP: For transferring set data to the DFP-D3000.
- Link Mute Channels to Channel Select: For linking the B-chain adjustment channel selection to the Mute ON/OFF setting (Displayed when not linked)
- Unlink Mute Channels to Channel Select: For setting to not link the B-chain adjustment channel selection to the Mute ON/OFF setting (Displayed when linked)
- Nominalize EQ Bands: Offsets EQ in general
- Compare Project: Displays the difference in the comparison of the current setting and file setting in the disk

9.11.7 Description of Master Menu Items

The following shows the Master menu screen.

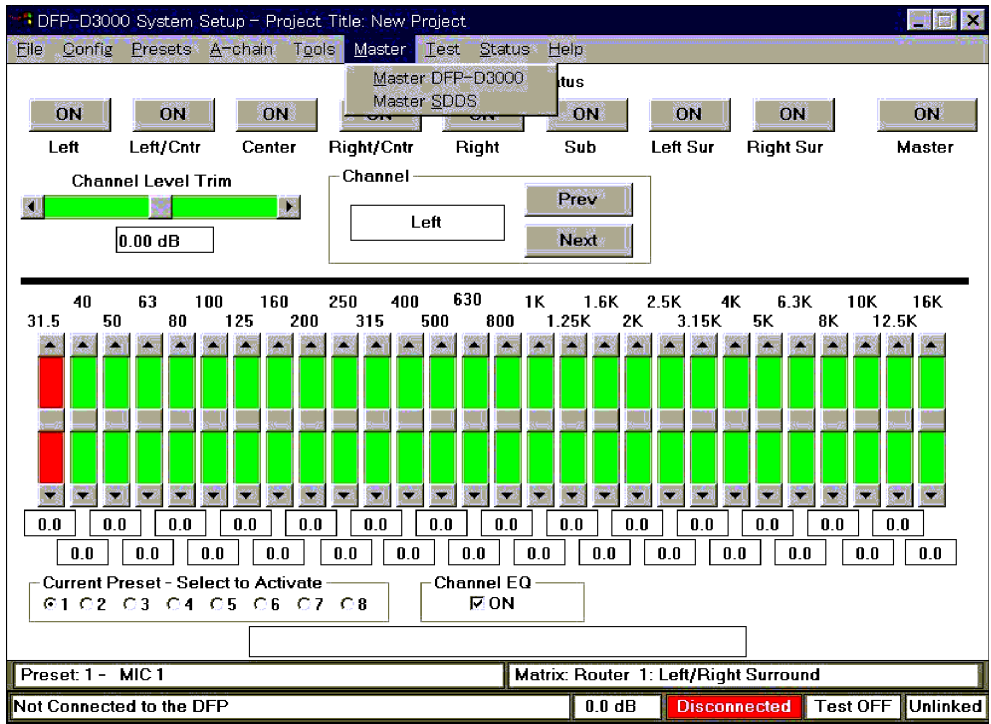

The items of the Master menu have the following functions.

Master DFP-D3000: For setting the DFP-D3000 output level and master fader

Master SDDS: For setting the SDDS lip sync and changeover

9.11.8 Description of Test Menu Items

The following shows the Test menu screen.

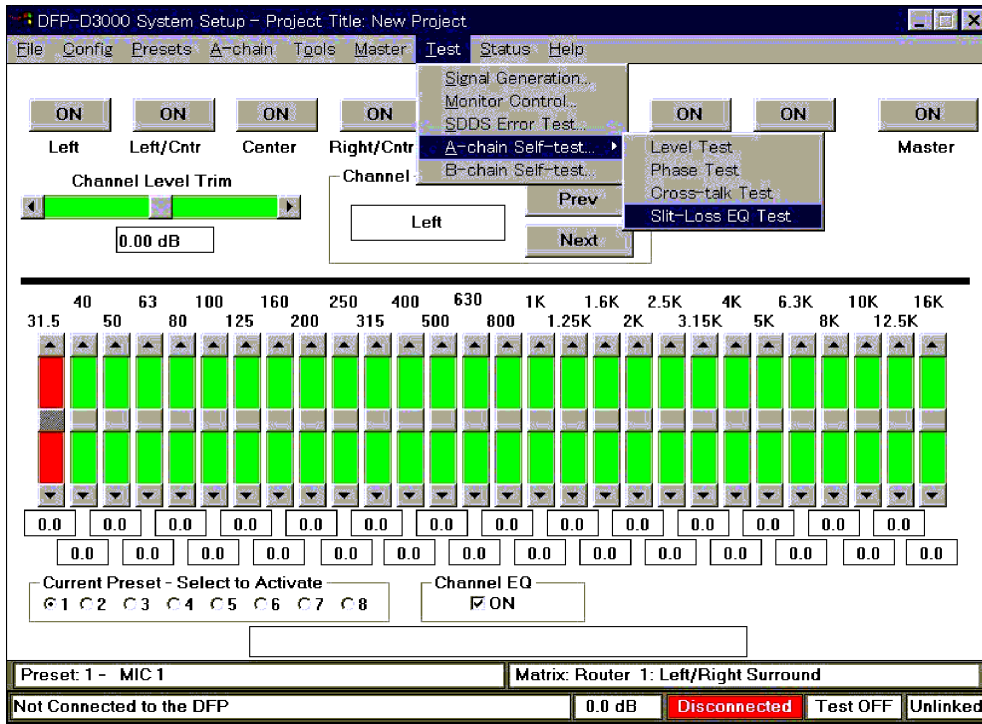

The items of the Test menu have the following functions.

Signal Generation: For setting the test signal generation

Monitor Control: For setting the headphone monitor

Linear Error Test: For checking the SDDS playback state and film state

A-Chain Self Test: For checking PEC operations (Comparison with existing data)

Level Test: For checking the playback level

Phase Test: For checking the signal phase

Crosstalk Test: For checking the signal crosstalk state

Slit loss EQ Test: For checking the slit loss EQ setting

B-chain Self Test: B-chain operation test. For checking the speaker connections.

9.11.9 Description of Help Menu Items

The following shows the Help menu screen.

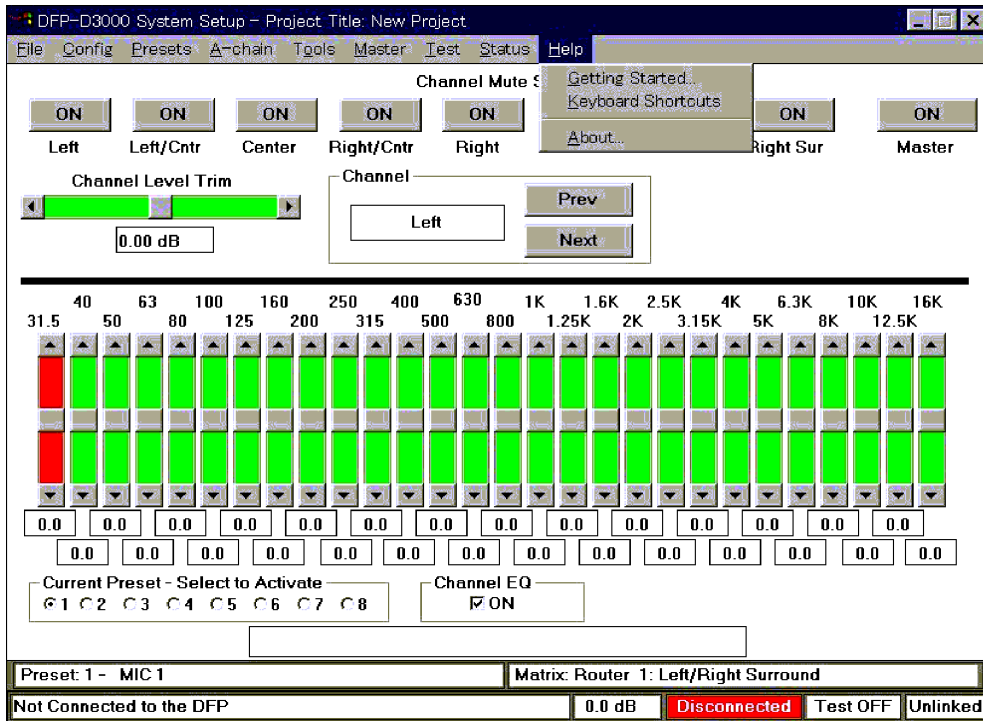

The items of the Help menu have the following functions.

- Getting Started: For displaying the initial help screen and accessing the English help items
- Keyboard short Cuts: Description of keyboard short cut
- About: For displaying the software version, Build number, and Copy Right

このマニュアルに記載されている事柄の著作権は当社にあります。

従って、当社の許可なしに無断で複写したり、説明内容(操作、保守等)と異なる目的で本マニュアルを使用することを禁止します。

The material contained in this manual consists of information that is the property of Sony Corporation. Sony Corporation expressly prohibits the duplication of any portion of this manual or the use thereof for any purpose other than the operation or maintenance of the equipment described in this manual without the express written permission of Sony Corporation.

Le matériel contenu dans ce manuel consiste en informations qui sont la propriété de Sony Corporation. Sony Corporation interdit formellement la copie de quelque partie que ce soit de ce manuel ou son emploi pour tout autre but que des opérations ou entretiens de l'équipement à moins d'une permission écrite de Sony Corporation.

Das in dieser Anleitung enthaltene Material besteht aus Informationen, die Eigentum der Sony Corporation sind. Die Sony Corporation untersagt ausdrücklich die Vervielfältigung jeglicher Teile dieser Anleitung oder den Gebrauch derselben für irgendeinen anderen Zweck als die Bedienung oder Wartung der in dieser Anleitung beschriebenen Ausrüstung ohne ausdrückliche schriftliche Erlaubnis der Sony Corporation.

DFP-D3000 (SY)
DFP-R3000 (SY) E
9-976-890-02

Sony Corporation
Communication System Solutions Network Company

Printed in Japan
2001. 1 08
©2000

Free Manuals Download Website

<http://myh66.com>

<http://usermanuals.us>

<http://www.somanuals.com>

<http://www.4manuals.cc>

<http://www.manual-lib.com>

<http://www.404manual.com>

<http://www.luxmanual.com>

<http://aubethermostatmanual.com>

Golf course search by state

<http://golfingnear.com>

Email search by domain

<http://emailbydomain.com>

Auto manuals search

<http://auto.somanuals.com>

TV manuals search

<http://tv.somanuals.com>