

**SONY**<sup>®</sup>

3-859-544-12(1)

# *Mini Hi-Fi Component System*

---

Operating Instructions

f

*MHC-RX90*

©1996 by Sony Corporation

## WARNING

To prevent fire or shock hazard, do not expose the unit to rain or moisture.

To avoid electrical shock, do not open the cabinet. Refer servicing to qualified personnel only.

Do not install the appliance in a confined space, such as a bookcase or built-in cabinet.

Laser component in this product is capable of emitting radiation exceeding the limit for Class 1.

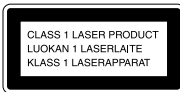

This appliance is classified as a CLASS 1 LASER product. The CLASS 1 LASER PRODUCT MARKING is located on the rear exterior.

This caution label is located inside the unit.

CAUTION	; INVISIBLE LASER RADIATION WHEN OPEN. AVOID EXPOSURE TO BEAM.
ADVARSEL	; USYNLIG LASERSTRÅLING VED ÅBNING NÅR SIKKERHEDSÅBRYDERE ER I GÆRBRUG. UNDGÅ UDSÆTTELSE FOR STRÅLING.
VARO!	; AVATTAESSA JA SUOJALUKITUS OHIETTAESSA DET ALTIINKA LASERLÄTTELYLLE.
VARNING	; LASERSTRÅLING NÄR DENNA DEL ÄR ÖPPNAD OCH SPÄRREN ÄR URÖPPPLAD.
ADVARSEL	; USYNLIG LASERSTRÅLING NÄR DEKSEL ÅPNES. UNDGÅ EKSPONERING FÖR STRÅLEN.

This stereo system is equipped with the Dolby\* B-type noise reduction system.

\* Dolby noise reduction manufactured under licence from Dolby Laboratories Licencing Corporation.

"DOLBY" and the double-D symbol are trademarks of the Dolby Laboratories Licencing Corporation.

---

# Table of Contents

---

## Getting Started

Step 1: Hooking up the system .....	4
Step 2: Setting the time .....	6
Step 3: Presetting radio stations .....	7
Connecting optional AV components .	8

## Basic Operations

Playing a CD .....	11
Recording a CD .....	13
Listening to the radio .....	14
Recording from the radio .....	15
Playing a tape .....	16
Recording from a tape .....	18

## The CD Player

Using the CD display .....	19
Playing the CD tracks repeatedly .....	19
Playing the CD tracks in random order .....	20
Programming the CD tracks .....	21
Playing CDs without interruption .....	22

## The Tape Deck

Recording on a tape manually .....	23
Recording a CD by specifying track order .....	24

## DJ Effects

Looping part of a CD .....	26
Flashing part of a CD .....	26
Waving the equalizer .....	27
Using the drum pads .....	27
Using the beat function .....	28

## Sound Adjustment

Adjusting the sound .....	29
Selecting the audio emphasis .....	30
Adjusting the audio emphasis .....	31
Making a personal audio emphasis file .....	33
Switching the speaker formation .....	34

## Other Features

Using the Radio Data System (RDS)*	36
Singing along: Karaoke .....	38
Falling asleep to music .....	39
Waking up to music .....	40
Timer-recording radio programmes..	41

## Additional Information

Precautions .....	43
Troubleshooting .....	44
Specifications .....	47
Index .....	49

\* For Western European model only

## Getting Started

### Step 1: Hooking up the system

Do the following procedure 1 to 4 to hook up your system using the supplied cords and accessories.

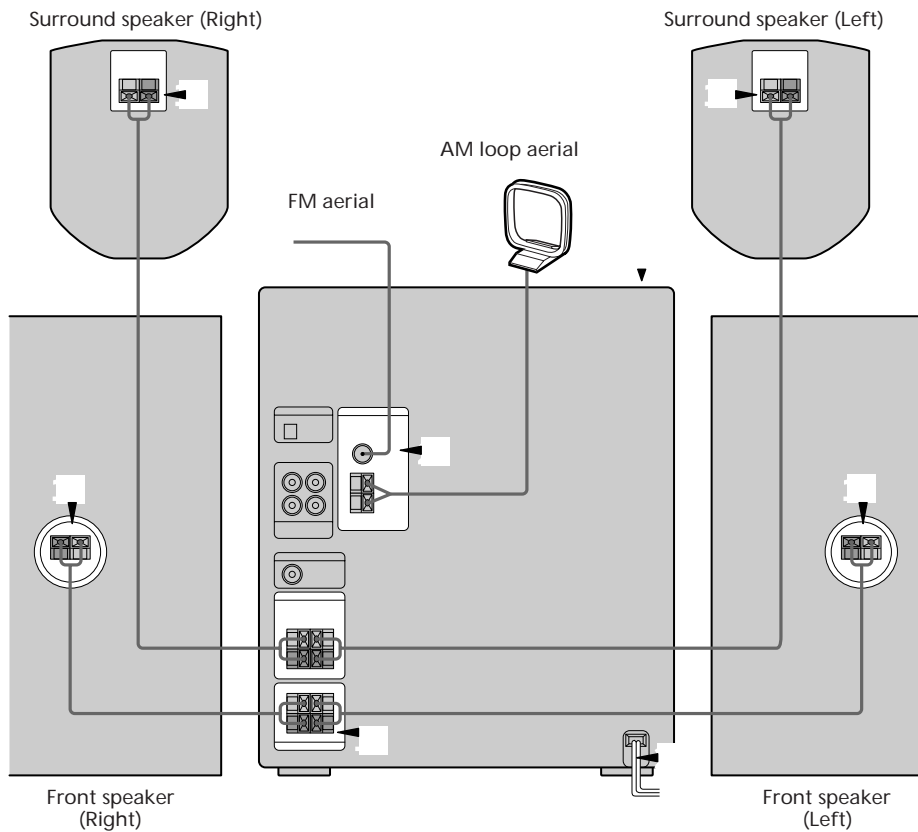

#### 1 Connect the speakers.

1 Connect the speaker cords of front speakers to the SPEAKER jacks of the same colour .

Keep the speaker cords away from the aerials to prevent noise.

2 Connect the speaker cords of surround speakers to the SURROUND SPEAKER jacks of the same colour .

Keep the speaker cords away from the aerials to prevent noise.

Insert only the stripped portion.

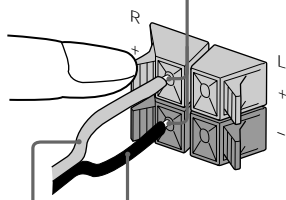

4

Red (+) Black (-)

**Note**

Do not place the surround speakers on top of a TV. This may cause distortion of the colours in the TV screen.

Insert only the stripped portion.

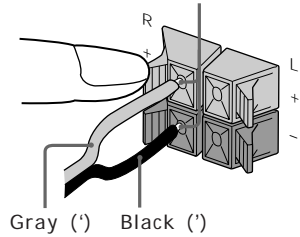

- 
- 2 Connect the FM/AM aeri-als.  
Set up the AM loop aerial, then connect it.

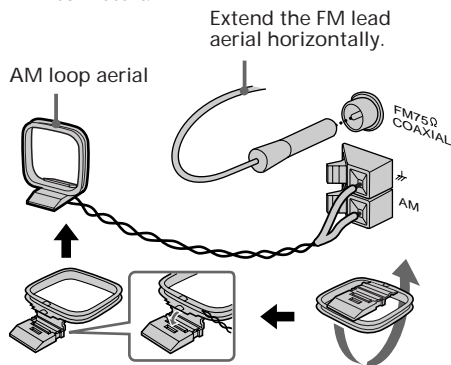

- 
- 3 Connect the power cord to a wall outlet.

Demo mode appears in the display.

- 
- 4 Deactivate the demo mode by pressing DISPLAY/DEMO when the system power is turned off.

The demo mode is also deactivated when you set the time.

---

**To attach the front speaker pads**

Attach the supplied front speaker pads to the bottom of the speakers to stabilize the speakers and prevent them from slipping.

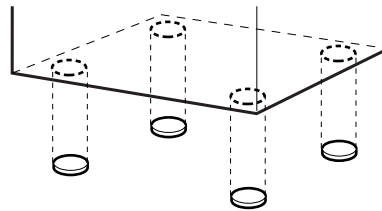

continued

**Step 1: Hooking up the system  
(continued)**

**Inserting two size AA (R6)  
batteries into the remote**

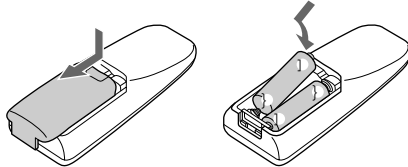

**Tip**

With normal use, the batteries should last for about six months. When the remote no longer operates the system, replace both batteries with new ones.

**Note**

If you do not use the remote for a long period of time, remove the batteries to avoid possible damage from battery leakage.

**When carrying this system**

Do the following to protect the CD mechanism.

- 1 Press FUNCTION repeatedly until "CD" appears in the display.
- 2 Hold down PLAY MODE and press POWER so that "LOCK" appears in the display.

---

**Step 2: Setting the  
time**

You must set the time before using the timer functions.

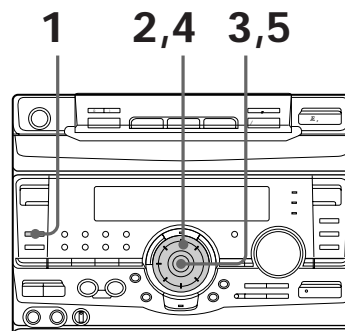

- 
- 1 Press CLOCK/TIMER SET.  
The hour indication flashes.



- 2 Turn the jog dial to set the hour.  
The clock is on a 24-hour system.

- 
- 3 Press ENTER/NEXT.  
The minute indication flashes.



- 
- 4 Turn the jog dial to set the minute.

- 
- 5** Press ENTER/NEXT.  
The clock starts working.
- 

**Tips**

- If you've made a mistake, start over from step 1.
- Setting the time deactivates the demo mode.  
If you want to display the demo mode, press DISPLAY/DEMO when the power is off.

**Note**

When setting the time, set the equalizer display to anything other than Spectrum analyzer pattern 3 (see "To change the equalizer display" on page 31).

---

## Step 3: Presetting radio stations

The 3 band model lets you preset up to 40 stations, 20 for FM, 10 for MW and 10 for LW.

The 4 band model lets you preset up to 45 stations, 20 for FM, 10 for MW, 10 for LW and 5 for UKV.

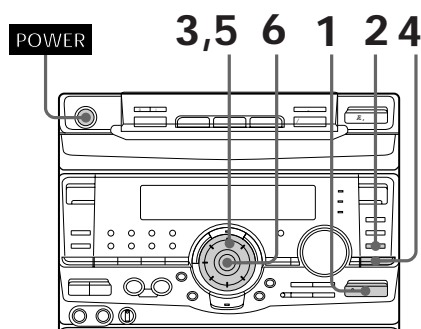

- 
- 1** Press TUNER/BAND repeatedly until the band you want appears in the display.

The bands you can receive vary depending on the model you purchased. Be sure to check which bands you can receive.

Every time you press this button, the band changes as follows:

3 band model:

FM n MW n LW  
└──────────┘

4 band model:

FM n MW n LW n UKV\*  
└──────────────────┘

\* "STEREO PLUS" is displayed when you select UKV.

continued

### Step 3: Presetting radio stations (continued)

**2** Press TUNING MODE repeatedly to select "AUTO".

**3** Turn the jog dial.  
The frequency indication changes and scanning stops when the system tunes in a station. "TUNED" and "STEREO" (for a stereo programme) appear.

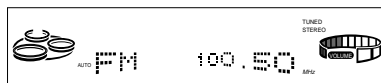

**4** Press TUNER MEMORY.  
A preset number appears in the display.

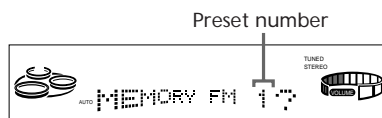

**5** Turn the jog dial to select the preset number you want.

**6** Press ENTER/NEXT.  
The station is stored.

**7** Repeat steps 1 to 6 to store other stations.

#### To tune in a station with a weak signal

Press TUNING MODE repeatedly to select "MANUAL" in step 2, then turn the jog dial to tune in the station.

#### To change the preset number

Start over from step 1.

#### Tip

The preset stations are retained for half a day even if you unplug the power cord or if a power failure occurs.

## Connecting optional AV components

To enhance your system, you can connect optional components. Refer to the instructions of each component.

### Connecting audio components

Select one of the following two connections, depending on the equipment to be connected and method of connecting.

#### Connecting an MD deck for digital recording

You can record from CD into the MD deck digitally by connecting an optical cable.

To the DIGITAL IN jack of the MD deck

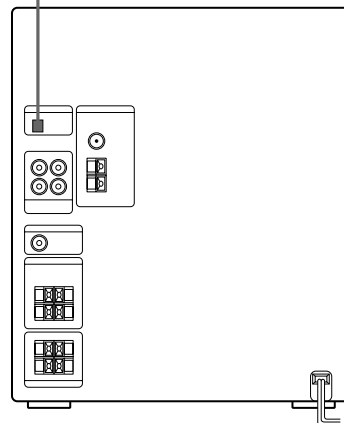



### Connecting an MD deck for analog recording

Make sure to match the colour of the plugs and the connectors. To listen to the sound of the connected MD deck, press FUNCTION repeatedly until "MD" appears.

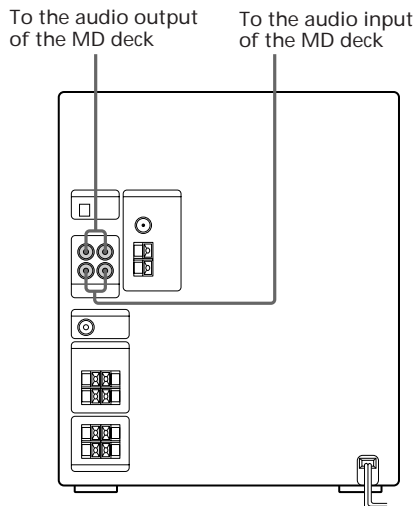

#### Note

If you cannot select "MD" even when you have pressed FUNCTION, press POWER while pressing FUNCTION when the power is turned off. "VIDEO" will be switched to "MD". To return to "VIDEO" do the same procedure.

#### Tip

If you connect a turntable with MM cartridge, connect it to VIDEO/MD IN using the optional MM cartridge equalizer EQ-2 and an audio connecting cord. To listen to the sound, press FUNCTION repeatedly until "VIDEO" appears.

### Connecting a super woofer speaker

You can connect an optional super woofer speaker.

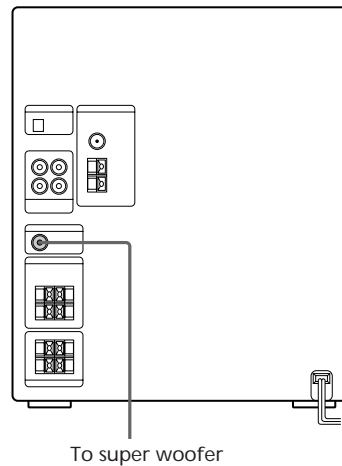

### Connecting a VCR

Make sure to match the colour of the plugs and the connectors. To listen to the sound of the connected VCR, press FUNCTION repeatedly until "VIDEO" appears.

To the audio output of the VCR

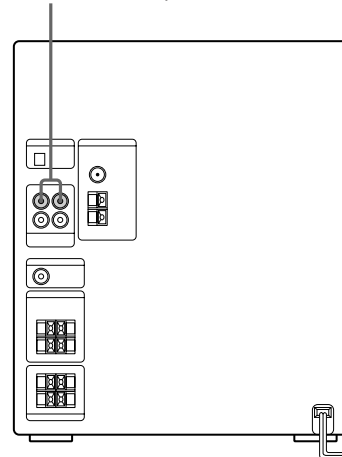

#### Note

If the sound is distorted when selecting "VIDEO", switch to "MD" (see previous "Note").

continued

**Connecting optional AV components (continued)**

**Connecting outdoor aerials**

Connect the outdoor aerial to improve the reception.

**FM aerial**

Connect the optional FM outdoor aerial. You can also use the TV aerial instead.

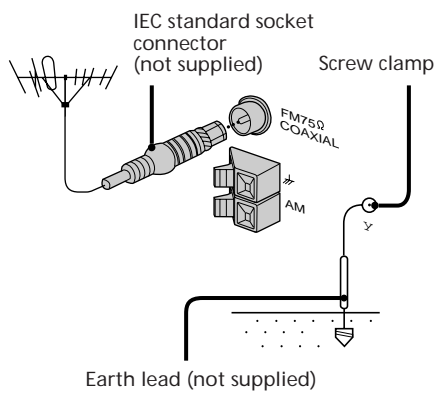

**AM aerial**

Connect a 6- to 15- meter (20- to 50- feet) insulated wire to the AM aerial terminal. Leave the supplied AM loop aerial connected.

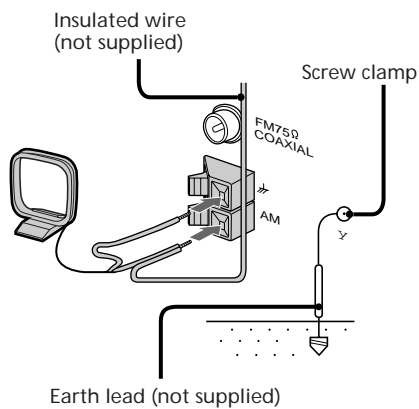

**Important**

If you connect an outdoor aerial, ground from y terminal with the screw clamp. To prevent a gas explosion, do not connect the earth lead to a gas pipe.



### Playing a CD (continued)

To	Do this
Stop play	Press $\cdot$ (p on the remote).
Pause	Press $\cdot$ (P on the remote). Press again to resume play.
Select a track	During play or pause, turn the jog dial clockwise (to go forward) or counterclockwise (to go back) and release it when you reach the desired track. Or press + (to go forward) or = (to go back) on the remote.
Find a point in a track	Press and hold down ) or 0 (or )/0 on the remote) during play and release it at the desired point.
Select a CD in stop mode	Press a DISC 1-3 button or DISC SKIP EX-CHANGE.
Play only the CD you have selected	Press 1/ALL DISCS repeatedly until "1 DISC" appears.
Play all CDs	Press 1/ALL DISCS repeatedly until "ALL DISCS" appears.
Remove the CD	Press § OPEN/CLOSE.
Exchange other CDs while playing	Press DISC SKIP EX-CHANGE.
Adjust the volume	Turn VOLUME (or press VOL +/- on the remote).

### Tips

- Pressing  $\cdot$  when the power is off automatically turns the power on and starts CD playback if there is a CD in the tray (One Touch Play).
- You can switch from another source to the CD player and start playing a CD just by pressing  $\cdot$  or the DISC 1-3 buttons (Automatic Source Selection).
- If there is no CD in the player, "CD NO DISC" appears in the display.
- When a disc tray is selected or the CD placed on that tray is playing, the DISC 1-3 button for the respective tray lights green.

## Recording a CD

### — CD Synchro Recording

The CD SYNCHRO button lets you record from a CD to a tape easily. You can use TYPE I (normal) or TYPE II (CrO<sub>2</sub>) tapes. The recording level is adjusted automatically.

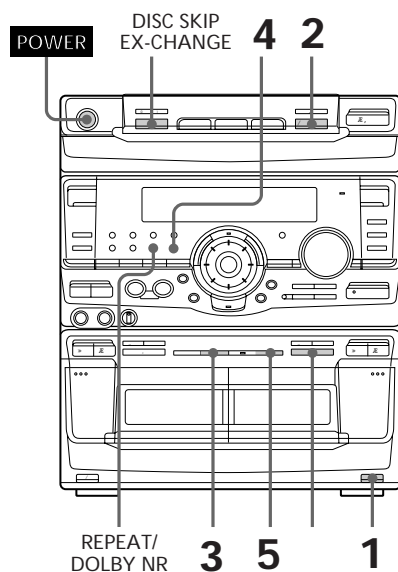

- 1 Press EJECT and insert a blank tape into deck B.

With the side you want to record facing forward

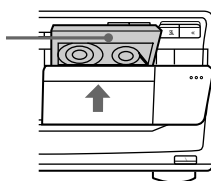

- 2 Press OPEN/CLOSE and place a CD.

Then press again to close the disc tray.

If the indicator for the tray you want to record is not lit green, press DISC SKIP EX-CHANGE repeatedly so that it lights green.

With the label side up. When you play a single CD, place it on the inner circle of the tray.

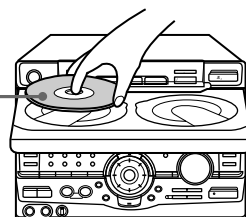

- 3 Press CD SYNCHRO. Deck B stands by for recording and the CD player stands by for playback. (for front side) lights up.
- 4 Press EDIT/DIRECTION repeatedly to select A to record on one side. Select a (or RELAY) to record on both sides.
- 5 Press on deck B. Recording starts.

### To stop recording

Press on deck B or on the CD player.

### Tips

- If you want to record from the reverse side, press so that (for reverse side) lights up.
- When you record on both sides, be sure to start from the front side. If you start from the reverse side, recording stops at the end of the reverse side.
- When you want to reduce the hiss noise in low-level high-frequency signals, press REPEAT/DOLBY NR so that "DOLBY NR B" appears after pressing CD SYNCHRO.

### Note

You cannot listen to other sources while recording.

## Listening to the radio

### -- Preset Tuning

Preset radio stations in the tuner's memory first (see "Step 3: Presetting radio stations").

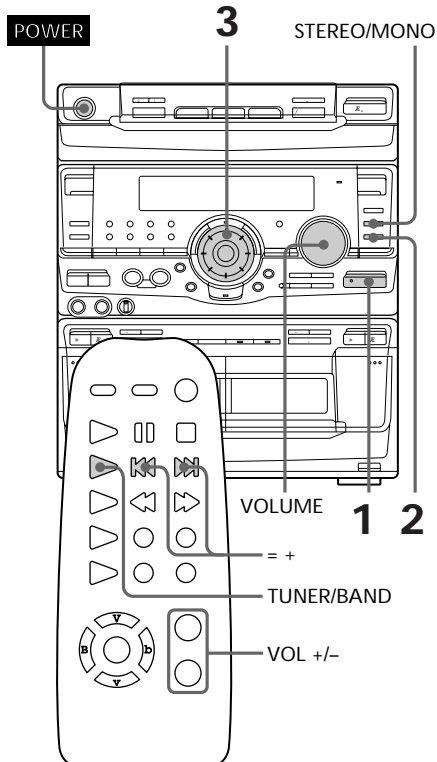

- 1 Press TUNER/BAND repeatedly until the band you want appears in the display.

The bands you can receive vary depending on the the model you purchased. Be sure to check which bands you can receive.

Every time you press the button, the band changes as follows:

3 band model:

FM n MW n LW

4 band model:

FM n MW n LW n UKV\*

\* "STEREO PLUS" is displayed when you select UKV.

- 2 Press TUNING MODE repeatedly so that "PRESET" appears in the display.

MANUAL n AUTO n PRESET

- 3 Turn the jog dial (or press = or + on the remote) to tune in the desired preset station.

Turn counter-clockwise (or press = on the remote) for lower preset numbers.

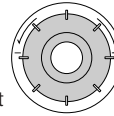

Turn clockwise (or press + on the remote) for higher preset numbers.

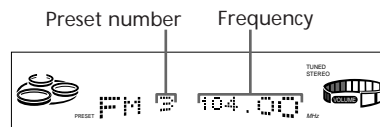

To	Do this
Turn off the radio	Press POWER.
Adjust the volume	Turn VOLUME (or press VOL +/- on the remote).

### To listen to non-preset radio stations

Press TUNING MODE repeatedly so that "MANUAL" appears in step 2, then tune in the station by turning the jog dial.

#### Tips

- Pressing TUNER/BAND when the power is off automatically turns the power on and tunes to the last received station (One Touch Play).
- You can switch from another source to the radio just by pressing TUNER/BAND (Automatic Source Selection).
- When an FM programme is noisy, press STEREO/MONO so that "MONO" appears in the display. There will be no stereo effect, but the reception will improve. Press the button again to restore the stereo effect.
- To improve broadcast reception, reorient the supplied aerials.

## Recording from the radio

You can record the radio programme on a tape by calling up a preset station. You can use TYPE I (normal) or TYPE II (CrO<sub>2</sub>) tapes. The recording level is automatically adjusted.

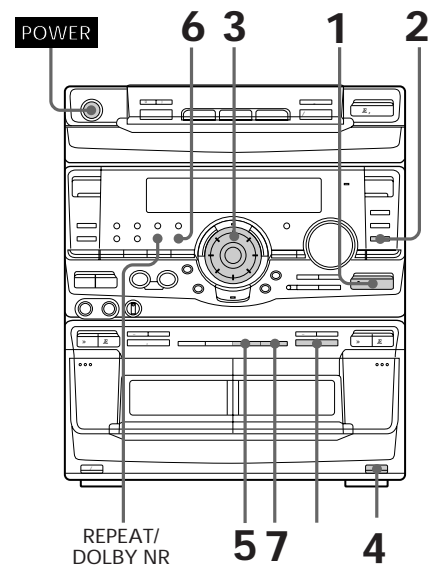

**1** Press TUNER/BAND to select the band you want.

**2** Press TUNING MODE so that "PRESET" appears in the display.

**3** Turn the jog dial to tune in a preset station.

Turn counter-clockwise for lower preset numbers.

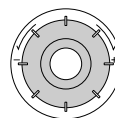

Turn clockwise for higher preset numbers.

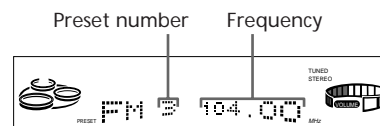

continued

### Recording from the Radio (continued)

- Press  $\text{\$}$  EJECT and insert a blank tape into deck B.

With the side you want to record facing forward

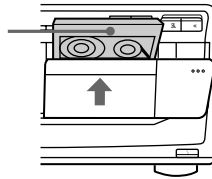

- Press  $\text{r}$ .  
Deck B stands by for recording.
- Press EDIT/DIRECTION repeatedly to select A to record on one side. Select a (or RELAY) to record on both sides.
- Press  $\text{a}$  on deck B.  
Recording starts.

### To stop recording

Press  $\text{a}$  on deck B.

### Tips

- If you want to record from the reverse side, press  $\text{a}$  so that  $\text{a}$  (for reverse side) lights up.
- When you record on both sides, be sure to start from the front side. If you start from the reverse side, recording stops at the end of the reverse side.
- To record non-preset stations, select "MANUAL" in step 2, then turn the jog dial to tune in the desired station.
- When you want to reduce the hiss noise in low-level high-frequency signals, press REPEAT/DOLBY NR so that "DOLBY NR B" appears after pressing  $\text{r}$ .
- If noise is heard while recording from the radio, move the respective aerial to reduce the noise.

## Playing a tape

You can use any type of tape, TYPE I (normal), TYPE II (CrO<sub>2</sub>) or TYPE IV (metal), since the deck automatically detects the tape type. To select either deck A or B, press DECK A or DECK B on the remote.

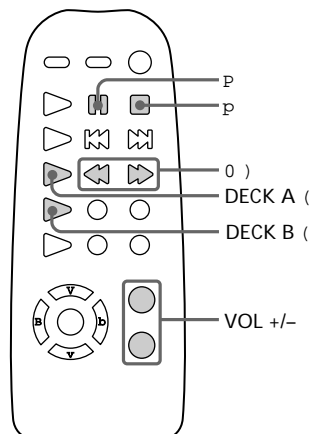
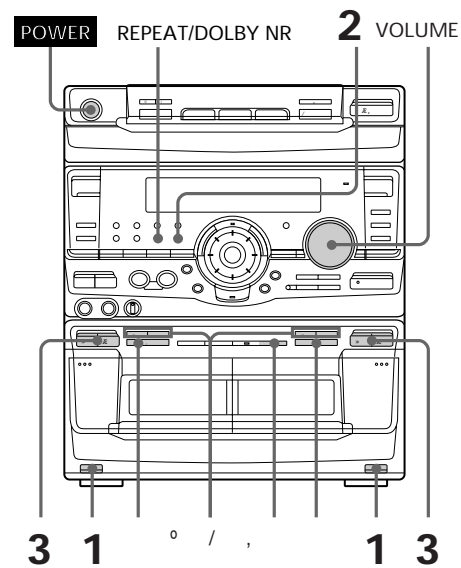



- 1** Press § EJECT and insert a recorded tape in deck A or B.

With the side you want to play facing forward

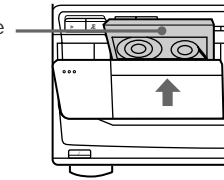

- 2** Press EDIT/DIRECTION repeatedly to select A to play one side. Select a\* to play both sides.

To play both decks in succession, select RELAY (relay play).\*\*

- 3** Press .

Press <sup>a</sup> to play the reverse side. The tape starts playing.

\* The deck stops automatically after repeating the sequence five times.

\*\* Relay play always follows the following sequence:

Deck A (front side), Deck A (reverse side),  
Deck B (front side), Deck B (reverse side).

To	Do this
Stop play	Press (or p on the remote).
Pause (Deck B only)	Press . Press again to resume play.
Fast-forward	Press , while playing the front side or ° while playing the reverse side.
Rewind	Press ° while playing the front side or , while playing the reverse side.
Remove the cassette	Press § EJECT.
Adjust the volume	Turn VOLUME (or press VOL +/- on the remote).

#### Tips

- Pressing . or <sup>a</sup> when the power is off automatically turns the power on and starts tape playback if there is a tape in the deck (One Touch Play).
- You can switch from another source to the tape deck just by pressing . or <sup>a</sup> (Automatic Source Selection).
- When you want to reduce the hiss noise in low-level high-frequency signals, press REPEAT/DOLBY NR so that "DOLBY NR B" appears.
- When dubbing tapes originally recorded with Dolby NR B, the dubbed tape is automatically played with Dolby NR B.

---

## Recording from a tape

### — High-speed Dubbing

You can use TYPE I (normal) or TYPE II (CrO<sub>2</sub>) tapes. The recording level is automatically adjusted.

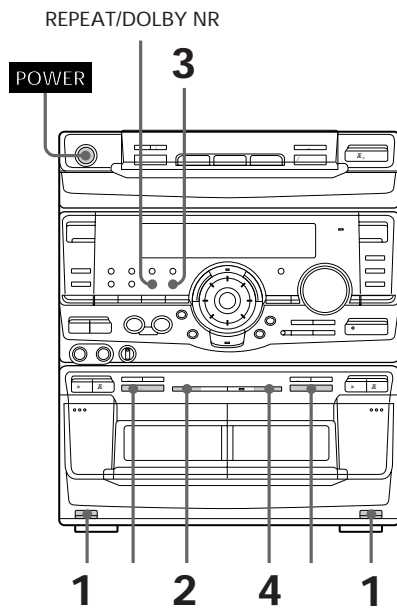

- 
- 1 Press § EJECT and insert a recorded tape in deck A and a blank tape in deck B.

With the side you want to play/record facing forward

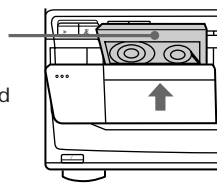

- 
- 2 Press HIGH SPEED DUBBING. Deck B stands by for recording.

- 
- 3 Press EDIT/DIRECTION repeatedly to select A to record on one side. Select a (or RELAY) to record on both sides.

- 
- 4 Press . Dubbing starts.
- 

### To stop dubbing

Press on deck A or B.

### Tips

- When you dub on both sides, start recording from the front side. If you record from the reverse side, recording stops at the end of the reverse side.
- If you set EDIT/DIRECTION to a when the tapes you use have different lengths, the tape in each deck reverses independently. If you select RELAY, the tapes in both decks reverse together.
- You don't have to set REPEAT/DOLBY NR, since the tape in deck B is automatically recorded in the same state as the tape in deck A.

## The CD Player

### Using the CD display

You can check the remaining time of the current track or that of the CD.

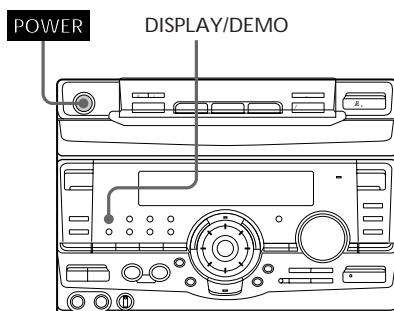

- / Press DISPLAY/DEMO during playback.  
Each time you press the button during normal playback, the display changes as follows:

- Playing time on the current track  
μ
- Remaining time on the current track  
μ
- Remaining time on current CD (1 DISC mode) or "PLAY" display (ALL DISCS mode)  
μ
- Clock display (for eight seconds)  
μ
- Effect (P FILE) name or "EFFECT ON (OFF)"  
μ

#### To check the total playing time and the number of tracks on a CD

Press DISPLAY/DEMO in the stop mode.

If you press DISPLAY/DEMO again, the clock display appears for eight seconds then the display returns to the previous indication.

### Playing the CD tracks repeatedly

#### -- Repeat Play

This function lets you repeat a single CD or all CDs in normal play, Shuffle Play and Programme Play.

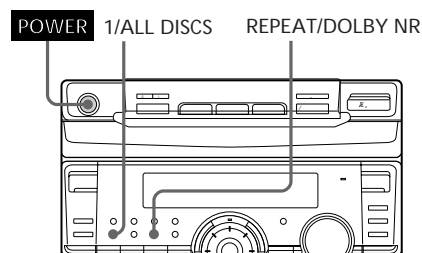

- / Press REPEAT/DOLBY NR during playback until "REPEAT" appears in the display.

Repeat Play starts. Do the following procedure to change the repeat mode.

To repeat	Press
All the tracks on the current CD	1/ALL DISCS repeatedly until "1 DISC" appears in the display.
All the tracks on all CDs	1/ALL DISCS repeatedly until "ALL DISCS" appears in the display.
Only one track*	REPEAT/DOLBY NR repeatedly until "REPEAT 1" appears in the display while playing the track you want to repeat.

\* You can't repeat a single track during Shuffle Play and Programme Play.

#### To cancel Repeat Play

Press REPEAT/DOLBY NR so that "REPEAT" or "REPEAT 1" disappears from the display.

---

## Playing the CD tracks in random order

### -- Shuffle Play

You can play all the tracks on one CD or all CDs in random order.

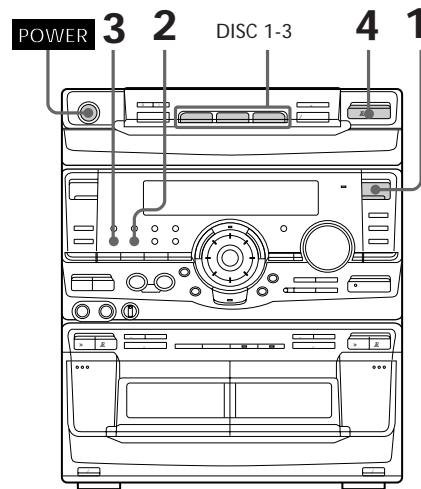

- 1** Press FUNCTION repeatedly until "CD" appears in the display, then place a CD.
  - 2** Press PLAY MODE repeatedly until "SHUFFLE" appears in the display.
  - 3** Press 1/ALL DISCS to choose "1 DISC" or "ALL DISCS".  
"ALL DISCS" shuffles all the CDs in the player. "1 DISC" shuffles the CD whose DISC indicator is green.
  - 4** Press . . .  
"J" appears and then all the tracks play in random order.
- 

### To cancel Shuffle Play

Press PLAY MODE repeatedly until "SHUFFLE" or "PROGRAM" disappears from the display. The tracks continue playing in their original order.

### To select a desired CD

Press DISC 1~3.

### Tips

- You can start Shuffle Play during normal play by pressing PLAY MODE repeatedly to select "SHUFFLE".
- To skip a track, turn the jog dial clockwise (or press + on the remote).

## Programming the CD tracks

### -- Programme Play

You can make a programme of up to 32 tracks from all the CDs in the order you want them to be played.

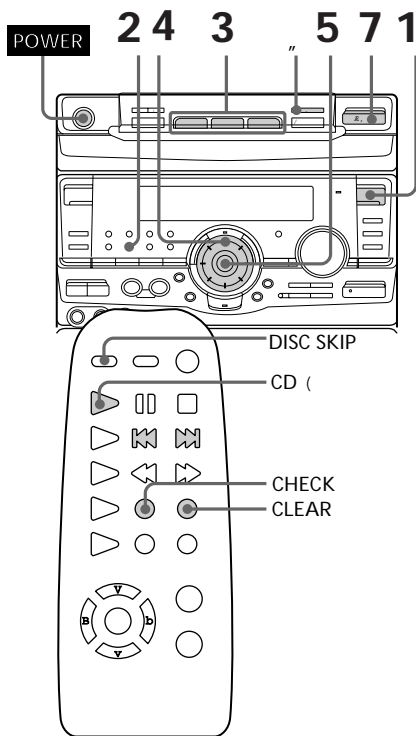

**1** Press FUNCTION repeatedly until "CD" appears in the display, then place a CD.

**2** Press PLAY MODE repeatedly until "PROGRAM" appears in the display.

**3** Press one of the DISC 1~3 buttons to select a CD.

**4** Turn the jog dial until the desired track appears in the display.

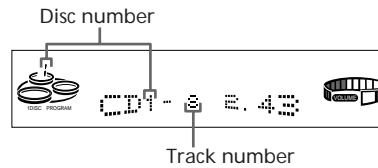

**5** Press ENTER/NEXT. The track is programmed. The programme step number appears, followed by the total playing time.

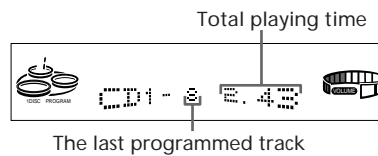

**6** To programme additional tracks, repeat steps 3 to 5. Skip step 3 to select tracks from the same disc.

**7** Press . . . All the tracks play in the order you selected.

### To cancel Programme Play

Press PLAY MODE repeatedly until "PROGRAM" or "SHUFFLE" disappears from the display.

continued

### Programming the CD tracks (continued)

To	Press
Check the programme	CHECK on the remote repeatedly. After the last track, "CHECK END" appears.
Clear a track from the end	CLEAR on the remote in stop mode.
Clear a specific track	CHECK on the remote repeatedly until the number of the track to be erased lights up, then press CLEAR.
Add a track to the programme	1 Select the disc tray with a DISC 1-3 button. 2 Select the track by turning the jog dial. 3 Press ENTER/NEXT.
Clear the entire programme	once in stop mode or twice while playing.

#### Tips

- The programme you made remains in the CD player even after it has been played back. Press **· ·** to play the same programme again.
- If "--.--" appears instead of the total playing time during programming, this means:
  - you have programmed a track number which exceeds 20
  - the total playing time has exceeded 100 minutes.

## Playing CDs without interruption

### -- Non-Stop Play/Applause Mix

You can play CDs without pausing between tracks or you can mix the sound of applause between tracks.

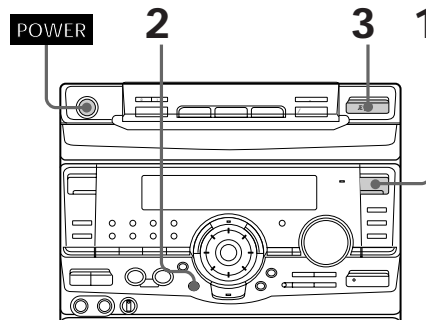

**1** Press FUNCTION repeatedly until "CD" appears in the display, then place a CD.

**2** Press NON-STOP repeatedly to select the mode you desire.

To	Select
Play without pausing between tracks	NON-STOP PLAY
Mix applause between tracks	APPLAUSE MIX

**3** Press **· ·**

#### To cancel Non-Stop Play

Press NON-STOP so that "NON-STOP OFF" appears in the display.

## The Tape Deck

### Recording on a tape manually

You can record from CD, tape, or radio as you like. For example, you can record just the songs you want or record from the middle of the tape. The recording level is adjusted automatically.

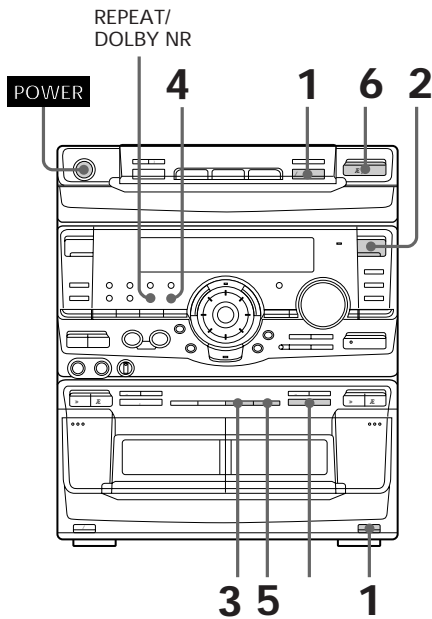

- 1** Insert a blank tape into deck B.
- 2** Press FUNCTION repeatedly until the source you want to record (e.g., CD) appears.
- 3** Press r.  
Deck B stands by for recording. (for front side) lights up.
- 4** Press EDIT/DIRECTION repeatedly to select A to record on one side. Select a (or RELAY) to record on both sides.

- 5** Press on deck B.  
Recording starts.

- 6** Start playing the source to be recorded.

To	Press
Stop recording	on the deck B
Pause recording	on the deck B

#### Tips

- If you want to record from the reverse side, press <sup>a</sup> so that <sup>a</sup> (for reverse side) lights up.
- When you want to reduce the hiss noise in low-level high-frequency signals, press REPEAT/DOLBY NR so that "DOLBY NR B" appears after pressing r.
- To skip tracks while recording from a tape, press , or ° on deck A. Deck B stands by for recording, and you can skip tracks. To resume dubbing, press on deck B.

## Recording a CD by specifying track order

### — Programme Edit

You can record tracks from all the CDs in the order you want. When programming, make sure the playing times for each side do not exceed the length of one side of the tape.

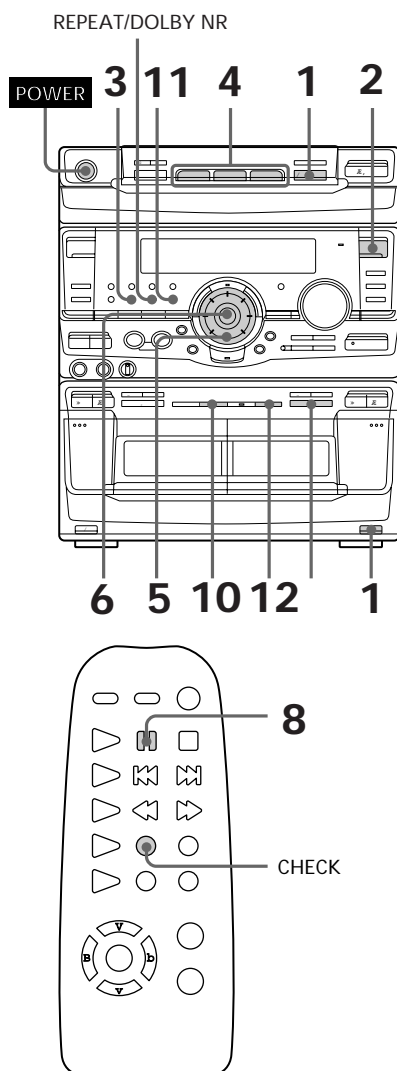

- 1** Place a CD and insert a blank tape into deck B.
- 2** Press FUNCTION repeatedly until "CD" appears in the display.
- 3** Press PLAY MODE repeatedly until "PROGRAM" appears in the display.
- 4** Press one of the DISC 1~3 buttons to select a CD.
- 5** Turn the jog dial until the desired track appears in the display.

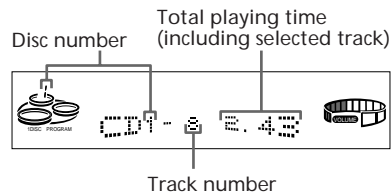

- 6** Press ENTER/NEXT. The track is programmed. The programme step number appears, followed by the total playing time.



- 7** To programme additional tracks to be recorded on side A, repeat steps 4 to 6. Skip step 4 to select tracks from the same disc.



---

**8** Press **PAUSE** on the remote to insert a pause at the end of side A.  
“P” appears in the display and the total playing time resets to “0.00” in the display.

---

**9** Repeat steps 5 and 6 for tracks from the same disc or steps 4 to 6 for tracks from another disc to programme the remaining tracks to be recorded on side B.

---

**10** Press **CD SYNCHRO**.  
Deck B stands by for recording and the CD player stands by for playback. (for front side) lights up.

---

**11** Press **EDIT/DIRECTION** repeatedly to select A to record on one side. Select a (or **RELAY**) to record on both sides.

---

**12** Press **RECORD** on deck B.  
Recording starts.

---

#### **To stop recording**

Press **STOP** on the deck B or on the CD player.

#### **To check the order**

Press **CHECK** on the remote repeatedly. After the last track, “CHECK END” appears.

#### **To cancel Programme Edit**

Press **PLAY MODE** repeatedly until “PROGRAM” or “SHUFFLE” disappears from the display.

#### **Tip**

When you want to reduce the hiss noise in low-level high-frequency signals, press **REPEAT/DOLBY NR** so that “DOLBY NR B” appears after pressing **CD SYNCHRO**.

## **Selecting tape length automatically**

### **—Tape Select Edit**

You can check the most suitable tape length for recording a CD. Note that you cannot use Tape Select Edit for discs containing more than 20 tracks.

---

**1** Insert a CD.

---

**2** Press **FUNCTION** repeatedly until “CD” appears in the display.

---

**3** Press **EDIT/DIRECTION** once, so that “EDIT” flashes.  
The required tape length for the currently selected CD appears, followed by the total playing time and tracks for side A and side B.

---

#### **Note**

You cannot use this function after programming. In order to use this function, you must first erase the programme (see “To clear the entire programme” on page 22).

## DJ Effects

### Looping part of a CD

#### — Loop

With the loop function, you can repeat part of a CD during playback. This lets you create original recordings.

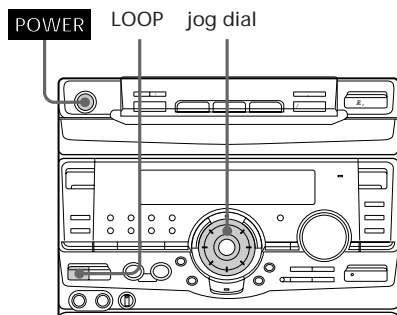

- 
- / Press and hold LOOP during playback at the point you want to start the Loop function, and release to resume normal play.
- 

#### To adjust the loop length

Turn the jog dial while holding LOOP (or press BEAT MENU B or b while holding LOOP on the remote) to select different loop lengths (LOOP 1~20).

### Flashing part of a CD

#### — Flash

With the flash function, you can “flash” the CD sound during playback. This lets you create original recordings.

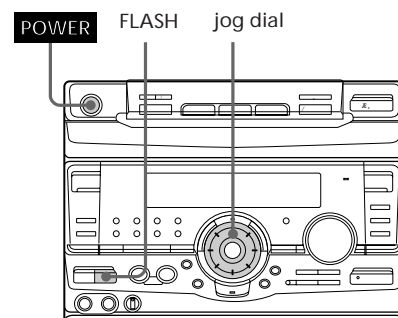

- 
- / Press and hold FLASH during playback at the point you want to start the Flash function, and release to resume normal play.
- 

#### To adjust the flash length

Turn the jog dial while holding FLASH (or press BEAT MENU B or b while holding FLASH on the remote) to select different flash lengths (FLASH 1~20).

#### To use LOOP and FLASH together

Press and hold both LOOP and FLASH at the same time.

#### Notes

- The loop and flash length cannot be adjusted during this operation. Adjust the loop and flash lengths independently beforehand if necessary.
- To record the flash effect, use the analog (VIDEO/MD OUT) connections or this unit's tape deck.

---

## Waving the equalizer

### — Wave

With the Wave function, you can fluctuate the graphic equalizer automatically. This effect can be used with any source, but it cannot be recorded.

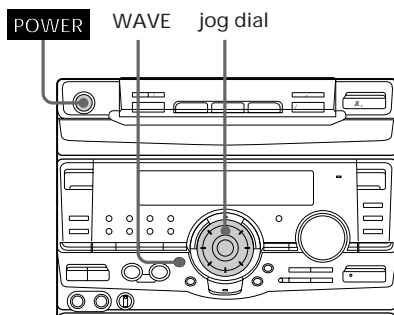

- 
- / Press and hold WAVE to start the Wave function, and release to resume normal listening.
- 

### To adjust the wave length

Turn the jog dial while holding WAVE to select a different wave length (WAVE 1~10).

---

## Using the drum pads

With the drum pads, you can add percussion during playback. This effect can be used with any source, to create original recordings.

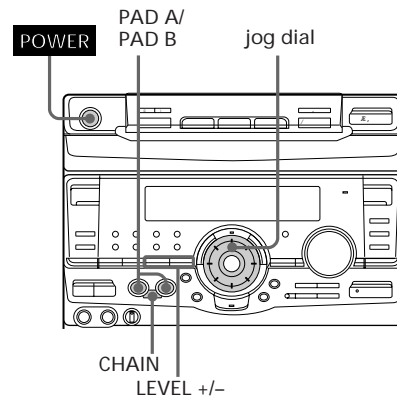

- 
- / Tap drum pad A or B to produce the respective sound.
- 

### To change the drum sound

Press and hold down pad A or B and turn the jog dial to select the sound you desire. You can select from 21 different drum sounds. The name of the drum sound appears in the display.

KICK~SNARE~ . . . ~SCRATCH PUSH  
⏪ \_\_\_\_\_ ⏩

The sound you select will be stored in pad A or B.

### To create a drum roll

Turn the jog dial while holding down CHAIN. You can vary the speed of the drums by turning the jog dial counterclockwise (for pad A) or clockwise (for pad B).

### To adjust the volume of the pads

Press LEVEL + or -.

### Note

When the APPLAUSE MIX function is selected, you will not hear the drum pad during the applause.

---

## Using the beat function

With the beat function, you can create a variety of rhythms automatically. This effect can be used with any source, to create original recordings.

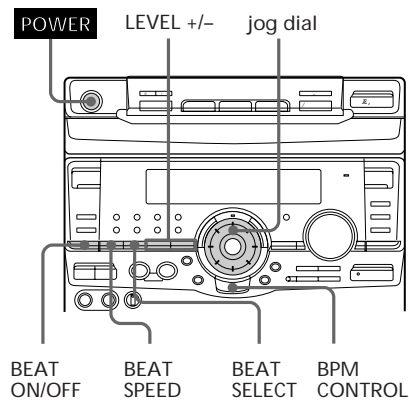

- 
- 1** Press BEAT ON/OFF to make sure the indicator is off, then start playing a source.

---

  - 2** Press BPM CONTROL repeatedly to obtain the beat speed you desire. Every time you press the button a voice says, "one, two, three, four, one . . .", the speeds (BPM 70~140) are also displayed. The beat speed is memorized automatically.

---

  - 3** Press BEAT ON/OFF to start the beat. Pressing BPM CONTROL lets you synchronize the beat with the source.
- 

### To change the speed

Hold down BEAT SPEED and turn the jog dial (or press BEAT SPEED +/- on the remote) to select the speed you desire (BPM 70~140).

### To change the beat pattern

You can select from 8 different beat patterns. Hold down BEAT SELECT and turn the jog dial (or press BEAT SELECT +/- on the remote) to select the pattern you desire. The name of the beat pattern appears in the display.

16 BEAT 1 ~ 16 BEAT 2 ~ . . . ~ SAMBA

### To cancel the beat

Press BEAT ON/OFF. Make sure the indicator is off.

### To change the beat volume

Press LEVEL + or -.

### Tip

You can use the drum pads and the beat function together.

### Note

When the APPLAUSE MIX function is selected, you will not hear the drum beat during the applause.

## Sound Adjustment

### Adjusting the sound

You can reinforce the bass, create a more powerful sound, and listen with headphones.

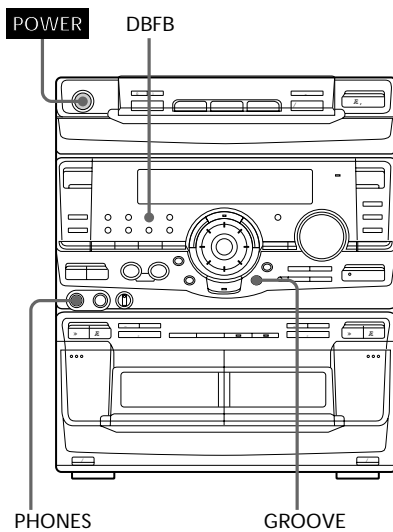

#### To reinforce bass (DBFB)

Press DBFB\*.

Every time you press the button, the display changes as follows:

DBFB ■■■ n DBFB ■■■■■ n display off

└──────────────────┘  
"DBFB ■■■■■" is more effective than  
"DBFB ■■■".

\* DBFB = Dynamic Bass Feedback

#### For a powerful sound (GROOVE)

Press GROOVE. The volume switches to power mode, DBFB is automatically set to full strength, the equalizer curve changes, and the "GROOVE" button lights up. Press GROOVE again to return to the previous volume.

#### Notes

- With some songs, the music will sound distorted when you use the DBFB system with the graphic equalizer if the bass is too strong. Adjust the bass slowly while listening to music so that you can monitor the effect of the adjustment.
- Cancelling GROOVE sets DBFB to "DBFB ■■■" and flattens the equalizer curve. To cancel the DBFB level, press DBFB until the indication disappears. Adjust the equalization to obtain the effect you desire.

#### To listen through the headphones

Connect the headphones to PHONES jack. No sound will come from the speakers.

#### Note

If you have connected a super woofer, please note that sound comes from the super woofer even when the headphones are connected. Turn off the power of the super woofer when using headphones.

## Selecting the audio emphasis

The audio emphasis menu lets you select the sound characteristic according to the sound you are listening to.

The personal file function (see “Making a personal audio emphasis file”) lets you store your own effects.

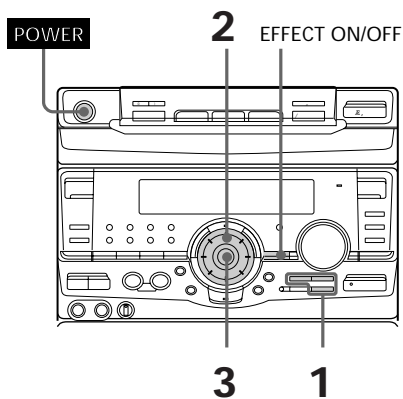

- 1 Press MUSIC, MOVIE, or GAME to select a menu.

See the chart “Music menu options” below. The last effect chosen from that menu appears in the display.

- 2 Use the jog dial to select the preset you desire.  
The preset name appears in the display.

- 3 Press ENTER/NEXT.

### To cancel the effect

Press EFFECT ON/OFF repeatedly so that “EFFECT OFF” appears in the display.

### Music menu options

“SUR ■■■■■■” appears if you select an effect with surround effects.

MENU button	Effect	For
MUSIC	ROCK	Standard music sources
	POP	
	JAZZ	
	DANCE	
	SOUL	
MOVIE	ACTION	Soundtracks and special listening situations
	ROMANCE	
	SF	
	DRAMA	
	SPORTS	
GAME	SHOOTING	Video games
	RACING	
	RPG	
	BATTLE	
	ADVENTURE	

### To change the equalizer display

Each time you press SPECTRUM ANALYZER, the equalizer display changes to show one of the four displays below.

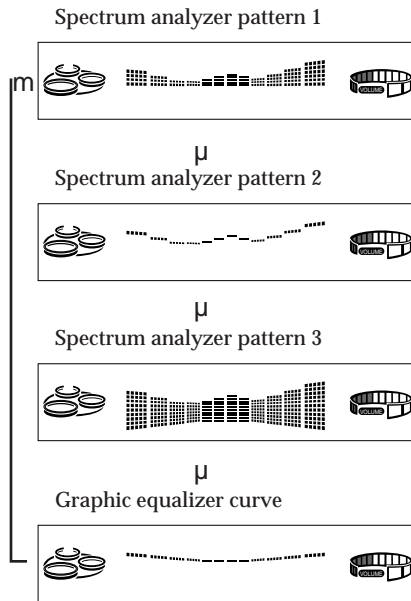

## Adjusting the audio emphasis

You can adjust the audio emphasis using the graphic equalizer and surround effect.

### Adjusting the graphic equalizer

You can adjust the sound by raising or lowering the levels of specific frequency ranges.

Before operation, first select the audio emphasis you want for your basic sound.

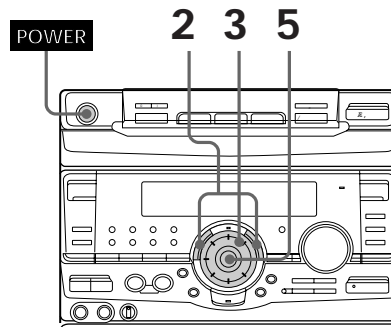

- 1 Select the audio emphasis you want for your basic sound (see "Selecting the audio emphasis").
- 2 Press HIGH FREQUENCY or LOW FREQUENCY repeatedly to select a frequency band.

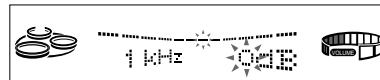

continued

### Adjusting the Audio Emphasis (continued)

- 3 Turn the jog dial to adjust level.

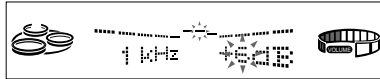

- 4 Repeat steps 2 and 3.
- 5 Press ENTER/NEXT when finished.

#### Note

If you choose another menu audio emphasis (other than "EFFECT OFF") the adjusted sound effect is lost. To retain the adjusted sound effect for future use, store it in a personal file. (See "Making a personal audio emphasis file".)

### Activating the surround effect

You can enjoy the surround effect.

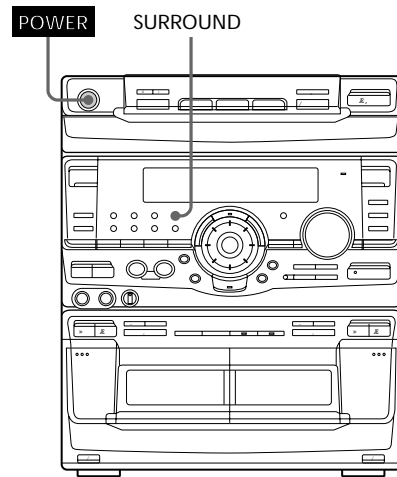

- / Press SURROUND repeatedly so that "SUR ■■■■■" appears in the display.

#### Note

When you choose other sound effects, the surround effects will be canceled. If you want to memorize the effect, store it into a personal file (see "Making a personal audio emphasis file").



---

## Making a personal audio emphasis file

### —Personal file

You can create a personal file of audio patterns (surround effect and graphic equalizer) and store them in the memory of the unit. Later call up an audio pattern to play a favourite tape, CD, or radio programme. Create up to five audio files.

Before operation, first select the audio emphasis you want for your basic sound.

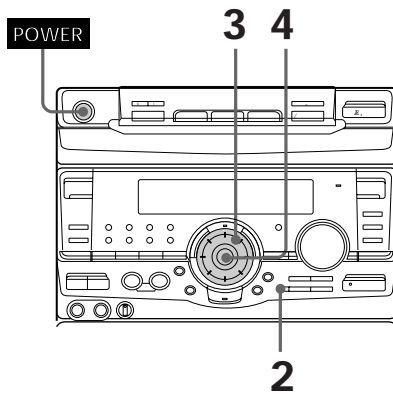

---

**1** Obtain the sound effect you want by using the graphic equalizer and surround effect.

---

**2** Press MEMORY.  
The personal file number appears in the display.

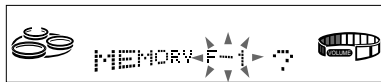

---

**3** Use the jog dial to select the file number (P FILE) where you want to store the sound effect.

---

**4** Press ENTER/NEXT.  
The adjusted sound effects are stored under the selected file number. The settings previously stored at this memory location are erased and replaced by the new settings.

---

### To call up the personal file

- 1 Press P FILE to display the last selected personal file.
- 2 Use the jog dial to select the personal file you desire.
- 3 Press ENTER/NEXT.

# Switching the Speaker Formation

## -Sonic formation

You can select from four speaker formations depending on your listening situation.

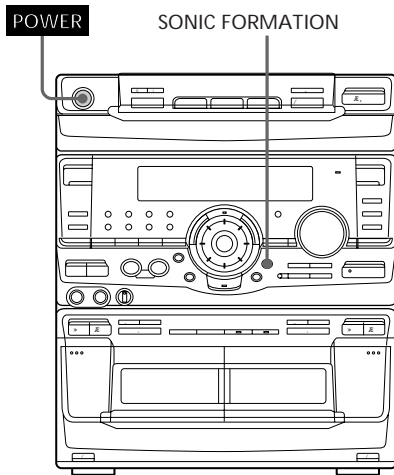

/ Press SONIC FORMATION repeatedly until the mode you want appears in the display.

As you press SONIC FORMATION, the mode changes as follows:

NORMAL n WHISPER n LINK



## NORMAL mode

The surround speakers provide reverberation and reflective sound effects that emphasize the sound from the front speakers.

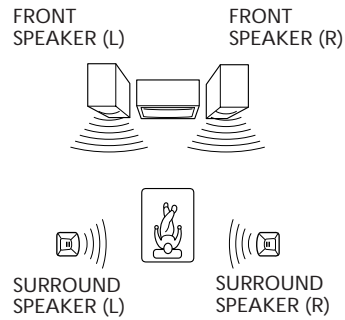

## WHISPER mode

The sound from the front speakers is cut off and output from the surround speaker with its sound decreased. For instance, when you want to listen to the sound in bed, it is suitable to set the surround speakers on either side of the bed.

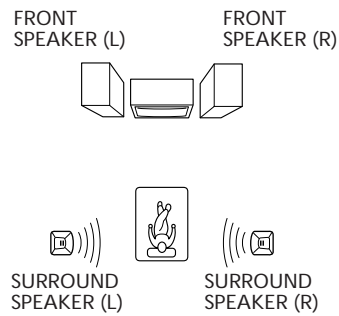

### LINK mode

The same sound is output from the front speakers and surround speakers. For instance, when you want to listen to the same sound in two rooms, it is suitable to set the front speakers and the surround speakers in each room.

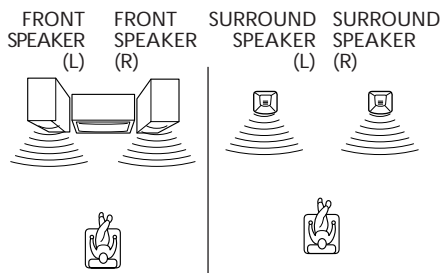

### FRONT ONLY mode

No sound is output from the surround speakers. Sound comes from the front speakers only.

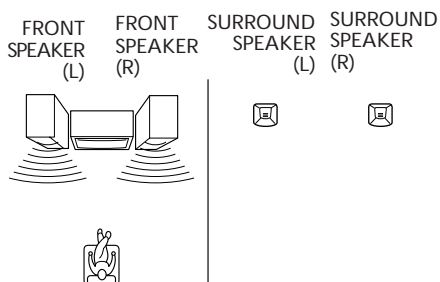

### Note

Do not place the surround speakers on top of a TV. This may cause distortion of the colours in the TV screen.

## Other Features

### Using the Radio Data System (RDS)

(For Western European model only)

#### What is the Radio Data System?

Radio Data System (RDS) is a broadcasting service that allows radio stations to send additional information along with the regular programme signal. This tuner offers convenient RDS features like station name display and location of stations by programme type. RDS is available only on FM stations.\*

#### Note

RDS may not work properly if the station you are tuned to is not transmitting the RDS signal properly or if the signal strength is weak.

\* Not all FM stations provide RDS service, nor do they provide the same type of services. If you are not familiar with the RDS system, check with your local radio stations for details on RDS services in your area.

### Receiving RDS broadcasts

- 
- / Simply select a station from the FM band.  
When you tune in a station that provides RDS services, the station name appears in the display.
- 

#### To check the RDS information

Each time you press DISPLAY/DEMO, the display changes as follows:

---

```
Station name*
µ
Frequency
µ
Programme type*
µ
Clock display
µ
Effect (P FILE) name or
"EFFECT ON (OFF)"
```

---

\* If the RDS broadcast is not received, the station name and programme type may not appear in the display

---

### Locating a station by programme type (PTY)

You can locate a station you want by selecting a programme type. The unit tunes in the type of programmes currently being broadcast from the RDS stations stored in the tuner's preset memory.

- 
- 1 Press PTY
- 
- 2 Turn jog dial to select the programme type you want. See the "List of programme types" section below.
- 
- 3 Press ENTER/NEXT.  
The unit starts searching the preset RDS stations ("SEARCH" and the selected programme type are shown alternately in the display).  
When the tuner receives a programme, the preset station number flashes.
- 
- 4 Turn jog dial to display the preset station number you desire.
-

- 
- 5** Press ENTER/NEXT while the preset station number is flashing.
- 

**To cancel PTY search**

Press PTY again.

**List of programme types (PTY)**

---

**AFFAIRS**

Topical programmes that expand on current news.

---

**ALARM**

Emergency broadcasts.

---

**CULTURE**

Programmes about national or regional culture.

---

**DRAMA**

Radio plays and serials

---

**EDUCATION**

Educational programmes, such as “how-to” programmes and advice.

---

**INFORMATION**

Programmes about consumer affairs, medical advice, and weather.

---

**LIGHT MUSIC**

Classical music, such as instrumentals, and vocal and choral works.

---

**M.O.R. MUSIC**

Easy listening (middle of the road music).

---

**NEWS**

News programmes

---

**OTHER MUSIC**

Music, such as jazz, rhythm and blues, and reggae.

---

**POP MUSIC**

popular music programmes

---

**ROCK MUSIC**

Rock music programmes

---

**SCIENCE**

Programmes about the natural sciences

---

**CLASSICS**

Performances of major orchestras, chamber music, opera, etc.

---

**SPORT**

Sports programmes

---

**VARIED**

Programmes containing celebrity interviews, panel games, and comedy.

---

**NONE**

Any programming not defined above

---

**Note**

“NO PTY” appears when the programme type that you selected is not currently being broadcast.

## Singing along: Karaoke

You can sing along with any stereo CD or tape by turning down the singer's voice. You need to connect an optional microphone.

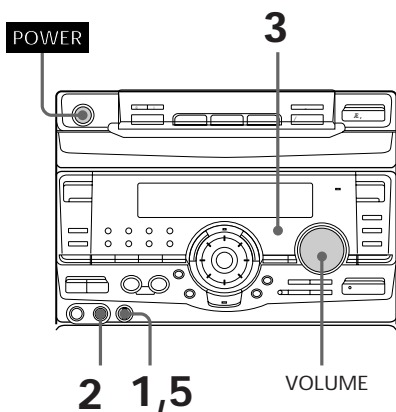

**1** Turn MIC LEVEL to 0 to turn down the microphone control level.

**2** Connect an optional microphone to MIX MIC.

**3** Press KARAOKE PON/MPX repeatedly to obtain the karaoke effect you desire.

Every time you press the button, the display changes as follows:

KARAOKE PON n MPX R n MPX L  
 ┌ EFFECT OFF (ON) ─┐

The h indicator appears in the display when a karaoke mode is activated.

To sing karaoke with decreasing the vocal level of a CD, select KARAOKE PON. To sing karaoke of multiplex CD or tape, select MPX R or MPX L.

**4** Start playing the music and adjust the volume.

**5** Adjust the microphone volume by turning MIC LEVEL.

### When you are done

Turn MIC LEVEL to 0 and disconnect the microphone from MIX MIC, then press KARAOKE PON/MPX repeatedly so that "h" disappears.

## Mixing and recording sounds

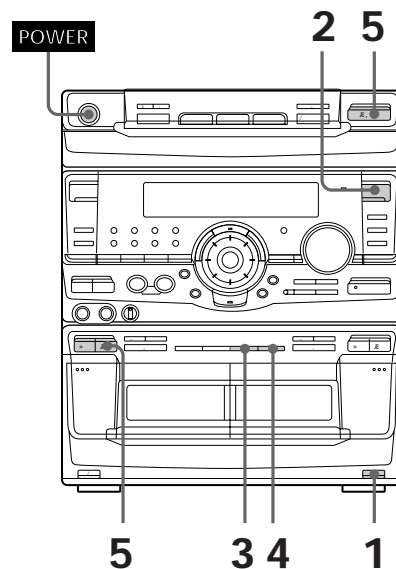

**1** Do the above steps 1 to 5. Then, insert a tape in deck B.

**2** Press FUNCTION repeatedly to select the source you desire and set it to pause mode.

---

**3** Press **r**.

---

**4** Press **.**

---

**5** Press **.** to start playing the CD player (or tape deck A).  
Playback starts. Start singing along with the music.

---

### To stop recording

Press **p** on deck B and the CD player.

#### Tips

- If acoustic feedback (howling) occurs, move the microphone away from the speakers or change the direction of the microphone.
- If you want to record your voice through the microphone only, you can do so by selecting the CD function and not playing a CD.

#### Notes

- If you press EFFECT ON/OFF or recall a sound effect, the karaoke mode is cancelled.
- The instrumental sound may be reduced as well as the singer's voice when the sound is recorded in monaural.
- The singer's voice may not be reduced when:
  - only a few instruments are playing
  - a duet is being played
  - the source has strong echoes or chorus
  - the singer's voice deviates from the centre.
  - the voice on the source is singing in high soprano or tenor.

---

## Falling asleep to music

### — Sleep Timer

You can let the system turn off at the preset time, so you can sleep to the music. You can preset the time to be turned off by 10 minutes.

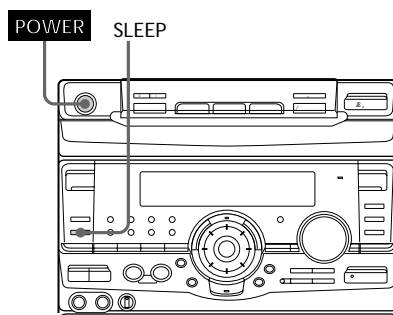

---

/ Press **SLEEP**.

Every time you press the button, the minute display (the turn-off time) changes as follows:

AUTO n 90min n 80min n 70min  
n ... n 10min n OFF n AUTO ...

---

### When you choose auto

The power turns off when the current CD or tape finishes playback (for up to 100 minutes).

### To check the remaining time

Press **SLEEP** once.

### To change the time to turn off

Select the time you want by pressing **SLEEP**.

### To cancel the Sleep Timer function

Press **SLEEP** repeatedly until "OFF" appears.

## Waking up to music

### — Wake-up Timer

You can wake up to music at a preset time every day. Make sure you have set the clock (see “Step 2: Setting the time”).

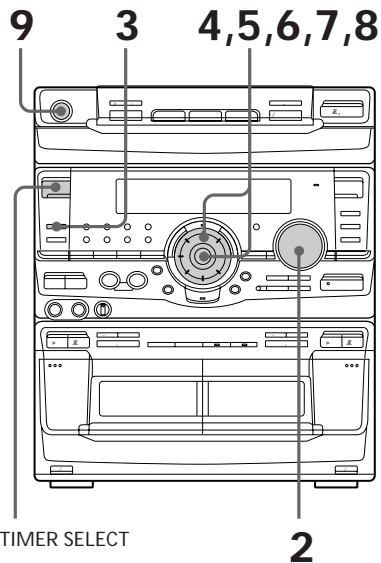

- 1 Prepare the music source you want to play.
  - CD: Insert a CD. To start from a specific track, make a programme (see “Programming the CD tracks”).
  - Tape: Insert an tape with the side you want to play facing forward.
  - Radio: Tune in the preset station you want (see “Step 3: Presetting radio stations”).

2 Adjust the volume.

3 Press CLOCK/TIMER SET.  
“SET (DAILY 1)” appears.

4 Turn jog dial to select DAILY 1 or 2, then press ENTER/NEXT.  
“ON” appears and the hour digits flash in the display.



5 Set the time to start playback.  
Turn jog dial to set the hour, then press ENTER/NEXT.  
The minute indication starts flashing.

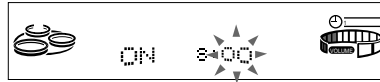

Turn jog dial to set the minute, then press ENTER/NEXT.  
The hour indication flashes again.

6 Set the time to stop playback following the above procedure.

7 Turn jog dial until the music source you want appears.  
The indications change as follows:  
TUNER n CD PLAY n TAPE PLAY

8 Press ENTER/NEXT.  
The start time, followed by the stop time and the music source, appears, then the original display appears.

9 Turn off the power.



### To check the setting

Press **TIMER SELECT** and turn the jog dial to select the respective mode (**DAILY 1** or **DAILY 2**), then press **ENTER/NEXT**. To change the setting, start over from step 1.

### To cancel the timer operation

Press **TIMER SELECT** and turn the jog dial to select **"OFF"**, then press **ENTER/NEXT**.

### Tip

The power turns on 15 minutes before the preset time.

### Note

When setting the wake-up timer, set the equalizer display to anything other than Spectrum analyzer pattern 3 (See **"To change the equalizer display"** on page 31).

---

## Timer-recording radio programmes

To timer-record, you must preset the radio station (see **"Step 3: Presetting radio stations"**) and set the clock (see **"Step 2: Setting the time"**) beforehand.

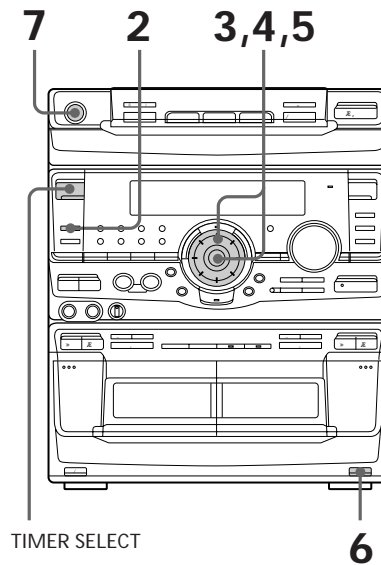

- 
- 1** Tune in the preset radio station (see **"Listening to the radio"**).
  - 2** Press **CLOCK/TIMER SET**.  
**"SET (DAILY 1)"** appears.

continued

### Timer-recording radio programmes (continued)

- Turn jog dial to select REC, then press ENTER/NEXT.  
"ON" appears and the hour digits flash in the display.

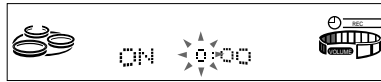

- Set the time to start recording.  
Turn jog dial to set the hour, then press ENTER/NEXT.  
The minute indication starts flashing.

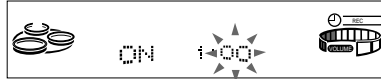

Turn jog dial to set the minute, then press ENTER/NEXT.  
The hour indication flashes again.

- Set the time to stop recording following the above procedure.  
The start time appears, followed by the stop time, the recording source and the radio station, then the original display appears.

- Insert a recordable tape.

- Turn off the power.  
When the recording starts, the volume level is set to the minimum.

#### To check the setting

Press TIMER SELECT and turn the jog dial to select "REC", then press ENTER/NEXT. To change the setting, start over from step 1.

#### To cancel the timer operation

Press TIMER SELECT and turn the jog dial to select "OFF", then press ENTER/NEXT.

#### Notes

- When setting the timer-recording, set the equalizer display to anything other than Spectrum analyzer pattern 3 (See "To change the equalizer display" on page 31).
- If the power is on at the preset time, the recording will not be made.

## Additional Information

### Precautions

#### On operating voltage

Before operating the system, check that the operating voltage of your system is identical with the voltage of your local power supply.

#### On safety

- The unit is not disconnected from the AC power source (mains) as long as it is connected to the wall outlet, even if the unit itself has been turned off.
- Unplug the system from the wall outlet (mains) if it is not to be used for an extended period of time. To disconnect the cord (mains lead), pull it out by the plug. Never pull the cord itself.
- Should any solid object or liquid fall into the component, unplug the stereo system and have the component checked by qualified personnel before operating it any further.
- The mains lead must be changed only at the qualified service shop.

#### On placement

- Place the stereo system in a location with adequate ventilation to prevent heat build-up in the stereo system.
- Do not place the unit in an inclined position.
- Do not place the unit in locations where it is;
  - Extremely hot or cold
  - Dusty or dirty
  - Very humid
  - Vibrating
  - Subject to direct sunlight

#### On operation

- If the stereo system is brought directly from a cold to a warm location, or is placed in a very damp room, moisture may condense on the lens inside the CD player. Should this occur, the system will not operate properly. Remove the CD and leave the system turned on for about an hour until the moisture evaporates.
- When you move the system, take out any discs.

If you have any questions or problems concerning your stereo system, please consult your nearest Sony dealer.

#### Notes on CDs

- Before playing, clean the CD with a cleaning cloth. Wipe the CD from the centre out.
- Do not use solvents such as benzene, thinner, commercially available cleaners or anti-static spray intended for vinyl LPs.
- Do not expose the CD to direct sunlight or heat sources such as hot air ducts, nor leave it in a car parked in direct sunlight.

#### Cleaning the cabinet

Use a soft cloth slightly moistened with mild detergent solution.

#### To save a tape permanently

To prevent a tape from being accidentally recorded over, break off the cassette tab from side A or B as illustrated. If you later want to reuse the tape for recording, cover the broken tab with adhesive tape.

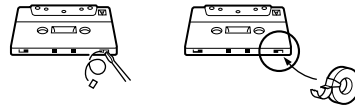

When you are using a TYPE II (CrO<sub>2</sub>) or TYPE IV (metal) cassette, be careful not to cover the detector slots which allow the tape player to automatically detect the type of tape.

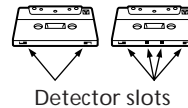

Detector slots

continued

## **Precautions (continued)**

### **Before placing a cassette in the tape deck**

Take up any slack in the tape. Otherwise the tape may get entangled in the parts of the tape deck and become damaged.

### **When using a tape longer than 90 minutes**

The tape is very elastic. Do not change the tape operations such as play, stop, and fast-winding etc. frequently. The tape may get entangled in the tape deck.

### **Cleaning the tape heads**

Clean the tape heads after every 10 hours of use.

When the tape heads become dirty

- the sound is distorted
- there is a decrease in sound level
- the sound drops out
- the tape does not erase completely
- the tape does not record

Make sure to clean the tape heads before you start an important recording or after playing an old tape. Use separately sold dry-type or wet-type cleaning cassette. For details, refer to the instructions of the cleaning cassette.

### **Demagnetizing the tape heads**

Demagnetize the tape heads and the metal parts that have contact with the tape every 20 to 30 hours of use with a separately sold demagnetizing cassette. For details, refer to the instructions of the demagnetizing cassette.

---

## **Troubleshooting**

If you run into any problem using this stereo system, use the following check list.

First, check that the power cord is connected firmly and the speakers are connected correctly and firmly.

Should any problem persist, consult your nearest Sony dealer.

### **General**

---

The display starts flashing as soon as you plug in the power cord even though you haven't turned on the power (demonstration mode).

- Press DISPLAY/DEMO when the power is turned off.

The demonstration mode appears automatically the first time you plug in the power cord. If there is a power outage lasting longer than half a day, redo the following:

- Clock setting (see "Step 2: Setting the time")
- Preset stations (see "Step 3: Presetting radio stations")
- Timer settings (see "Waking up to music" and "Timer recording radio programmes").

---

There is no sound.

- Rotate VOLUME clockwise.
- The headphones are connected.
- Insert only the stripped portion of the speaker cord into the SPEAKER jack. Inserting the vinyl portion of the speaker cord will obstruct the speaker connections.

---

**There is severe hum or noise.**

- A TV or VCR is placed too close to the stereo system. Move the stereo system away from the TV or VCR.

---

**The sound from the connected source is distorted.**

- If "VIDEO" appears in the display when you press FUNCTION, switch the display to "MD" (see "Notes: Connecting a VCR").

---

**"0:00" flashes in the display.**

- A power interruption occurred. Set the clock and timer settings again.

---

**The timer does not function.**

- Set the clock correctly.

---

**DAILY1, DAILY 2, and REC do not appear when you press the TIMER SELECT button.**

- Set the timer correctly.
- Set the clock.

---

**The remote does not function.**

- There is an obstacle between the remote and the system.
- The remote is not pointing in the direction of the system's sensor.
- The batteries have run down. Replace the batteries.

---

**There is acoustic feedback.**

- Decrease the volume level.
- Move the microphone away from the speakers or change the direction of the microphone.

---

**The colour irregularity on a TV screen persists.**

- Turn off the TV set once, then turn it on after 15 to 30 minutes. If the colour irregularity still persists, place the speakers farther away from the TV set.
- 

## Speakers

---

**Sound comes from one channel or unbalanced left and right volume.**

- Check the speaker connection and speaker placement.

---

**There is no sound from the surround speakers.**

- Press SONIC FORMATION to select a mode other than "FRONT ONLY".

---

**There is no sound from the front speakers.**

- Press SONIC FORMATION to select a mode other than "WHISPER".
- 

## CD Player

---

**The CD tray does not close.**

- The CD is not placed properly.

---

**The CD will not play.**

- The CD is not lying flat in the disc tray.
- The CD is dirty.
- The CD is inserted label side down.
- Moisture condensation has built up. Remove the CD and leave the system turned on for about an hour until the moisture evaporates.

---

**Play does not start from the first track.**

- The player is in programme or shuffle mode. Press PLAY MODE repeatedly until "PROGRAM" or "SHUFFLE" disappear.

---

**"OVER" is displayed.**

- You have reached the end of the CD. Press and hold 0 to return.
- 

continued

## Troubleshooting (continued)

### Tape Deck

---

The tape does not record.

- No tape in the cassette holder.
  - The tab has been removed from the cassette (see "To save a tape permanently" on page 43).
  - The tape has reeled to the end.
- 

The tape does not record nor play or there is a decrease in sound level.

- The heads are dirty. Clean them (see "Cleaning the tape heads" on page 44).
  - The record/playback heads are magnetized. Demagnetize them (see "Demagnetizing the tape heads" on page 44).
- 

The tape does not erase completely.

- The record/playback heads are magnetized. Demagnetize them (see "Demagnetizing the tape heads" on page 44).
- 

There is excessive wow or flutter, or the sound drops out.

- The capstans or pinch rollers are dirty. Clean them (see "Cleaning the tape heads" on page 44).
- 

Noise increases or the high frequencies are erased.

- The record/playback heads are magnetized. Demagnetize them (see "Demagnetizing the tape heads" on page 44).
- 

### Tuner

---

Severe hum or noise ("TUNED" or "STEREO" flashes in the display).

- Adjust the aerial.
  - The signal strength is too weak. Connect the external aerial.
- 

A stereo FM programme cannot be received in stereo.

- Press STEREO/MONO so that "STEREO" appears.
- 

**If other troubles not described above occur, reset the system as follows:**

- 1 Unplug the power cord.
- 2 Plug the power cord back in.
- 3 Press SPECTRUM ANALYZER, ENTER/NEXT, and DISC 1 at the same time.
- 4 Press POWER to turn on the power.

# Specifications

## Amplifier section

DIN power output	80 + 80 watts (8 ohms, at 1kHz, DIN)
Continuous RMS power output:	100 + 100 watts (8 ohms at 1 kHz, 10% THD)
Music power output:	160 + 160 watts (8 ohms at 1 kHz, 10% THD)
Inputs	VIDEO/MD IN (phono jacks): voltage 250 mV, impedance 47 kilohms MIX MIC (phone jack): sensitivity 1 mV, impedance 10 kilohms
Outputs	VIDEO/MD OUT (phono jacks): voltage 250 mV impedance 1 kilohms PHONES (stereo phone jack): accepts headphones of 8 ohms or more. SPEAKER: accepts impedance of 8 to 16 ohms SURROUND SPEAKER: accepts impedance of 16 ohms. SUPER WOOFER: Voltage 1 V, impedance 1 kilo ohm

## CD player section

System	Compact disc and digital audio system
Laser	Semiconductor laser ( $\lambda=780\text{nm}$ ) Emission duration: continuous
Laser output	Max. 44.6 $\mu\text{W}^*$ *This output is the value measured at a distance of 200 mm from the objective lens surface on the Optical Pick-up Block with 7 mm aperture.
Frequency response	2 Hz - 20 kHz ( $\pm 0.5$ dB)
Wavelength	780 - 790 nm
Signal-to-noise ratio	More than 90 dB
Dynamic range	More than 90 dB
CD OPTICAL DIGITAL OUT (Square optical connector jack, rear panel)	
Wavelength	600 nm
Output Level	-18 dBm

## Tape player section

Recording system	4-track 2-channel stereo
Frequency response (DOLBY NR OFF)	60 - 13,000 Hz ( $\pm 3$ dB), using Sony TYPE I cassette 60 - 14,000 Hz ( $\pm 3$ dB), using Sony TYPE II cassette
Wow and flutter	$\pm 0.15\%$ W.Peak (IEC) 0.1% W.RMS (NAB) $\pm 0.2\%$ W.Peak (DIN)

## Tuner section

FM stereo, FM/AM superheterodyne tuner

### FM tuner section

Tuning range	
3 band model:	87.5 - 108.0 MHz (50 kHz step)
4 band model:	65.0 - 74.0 MHz (10 kHz step) 87.5 - 108.0 MHz (50 kHz step)
Aerial	FM lead aerial
Aerial terminals	75 ohm unbalanced
Intermediate frequency	10.7 MHz

### UKV tuner section (4 band model only)

Tuning range	65.0 - 74.0 MHz (10kHz step) Polar stereo
--------------	---

### AM tuner section

Tuning range	MW: 531 - 1,602 kHz (with interval set at 9 kHz) LW: 153 - 279 kHz (with interval set at 3 kHz)
Aerial	AM loop aerial
Aerial terminals	External aerial terminal
Intermediate frequency	450 kHz

continued

## **Specifications (continued)**

### **Speaker**

#### **Front Speaker (SS-L90V)**

Speaker system	4-way, 5-unit, bass-reflex type
Speaker units	
Woofer:	17 cm, cone type
Centre Tweeter:	5 cm, cone type
Side Tweeter:	5 cm, cone type x2
Super Tweeter:	2 cm, dome type
Nominal impedance	8 ohms
Dimensions (w/h/d)	Approx. 220 x 330 x 315 mm
Mass	Approx. 5 kg net per speaker

#### **Surround Speaker (SS-SR101)**

Speaker system	1-way, 1-unit, bass-reflex type
Speaker units	
Full-range:	8 cm, cone type
Nominal impedance	16 ohms
Dimensions (w/h/d)	Approx. 205 x 95 x 240 mm
Mass	Approx. 1.1 kg net per speaker

### **General**

Power requirements	220 - 230 V AC , 50/60 Hz
Power consumption	230 watts
Dimensions (w/h/d)	Approx. 280 x 330 x 366 mm
Mass	Approx. 9.5 kg
Supplied accessories:	AM loop aerial (1) Remote RM-SD80 (1) Sony SUM-3 (NS) batteries (2) FM lead aerial (1) Speaker cords (4) Front speaker pads (8)

Design and specifications are subject to change without notice.



---

# Index

## A

- Adjusting
  - the audio emphasis 31
  - the sound 29
  - the volume 12, 14, 17
- Aerials 4, 10
- Automatic Source Selection 12, 15, 17

## B

- Batteries 6

## C

- CD player 11, 19
- CD Synchro Recording 13
- Clock setting 6
- Connecting. *See* Hooking up

## D

- Display 5, 19, 31

## E

- Edit 24

## F, G

- Flash 26

## H, I, J

- Hooking up
  - optional components 8
  - the aerials 5, 10
  - the power 5
  - the system 4

## K

- Karaoke 38

## L, M

- Loop 26

## N

- Normal Play 11

## O

- One Touch Play 12, 15, 17

## P, Q

- Personal file 33
- Playing
  - a CD 11
  - a preset radio station 14
  - tracks in random order (Shuffle Play) 20
  - tracks in the desired order (Programme Play) 21
  - tracks repeatedly (Repeat Play) 19
- Presetting radio stations 7
- Preset tuning 14
- Programme Play 21
- Protecting recordings 43
- PTY 36

## R

- Radio Data System 36
- Radio stations
  - presetting 7
  - tuning in 14
- Recording
  - a CD 13
  - a radio programme 15
  - timer recording 41
- Repeat Play 19
- Resetting the system 46

## S

- Saving recordings 43
- Selecting the audio emphasis 30
- Setting the time 6
- Shuffle Play 20
- Sleep Timer 39
- Sound adjustment 29
- Speakers 4, 9
- Sonic formation 34
- Station name 36

## T, U, V

- Timer
  - falling asleep to music 39
  - timer recording 41
  - waking up to music 40
- Troubleshooting 44
- Tuner 7, 14
- Tuning interval 8, 47

## W, X, Y, Z

- Wake-up timer 40
- Wave 27

Sony Corporation Printed in Indonesia



## Free Manuals Download Website

<http://myh66.com>

<http://usermanuals.us>

<http://www.somanuals.com>

<http://www.4manuals.cc>

<http://www.manual-lib.com>

<http://www.404manual.com>

<http://www.luxmanual.com>

<http://aubethermostatmanual.com>

Golf course search by state

<http://golfingnear.com>

Email search by domain

<http://emailbydomain.com>

Auto manuals search

<http://auto.somanuals.com>

TV manuals search

<http://tv.somanuals.com>